

LARGEST CIRCULATION OF ANY AVIATION MAGAZINE

# AIR TRAILS

★ COMPLETE

**BILL BARNES**

AIR NOVEL

DEATH RIDES THE SKY

by George L. Eaton

APRIL  
1937

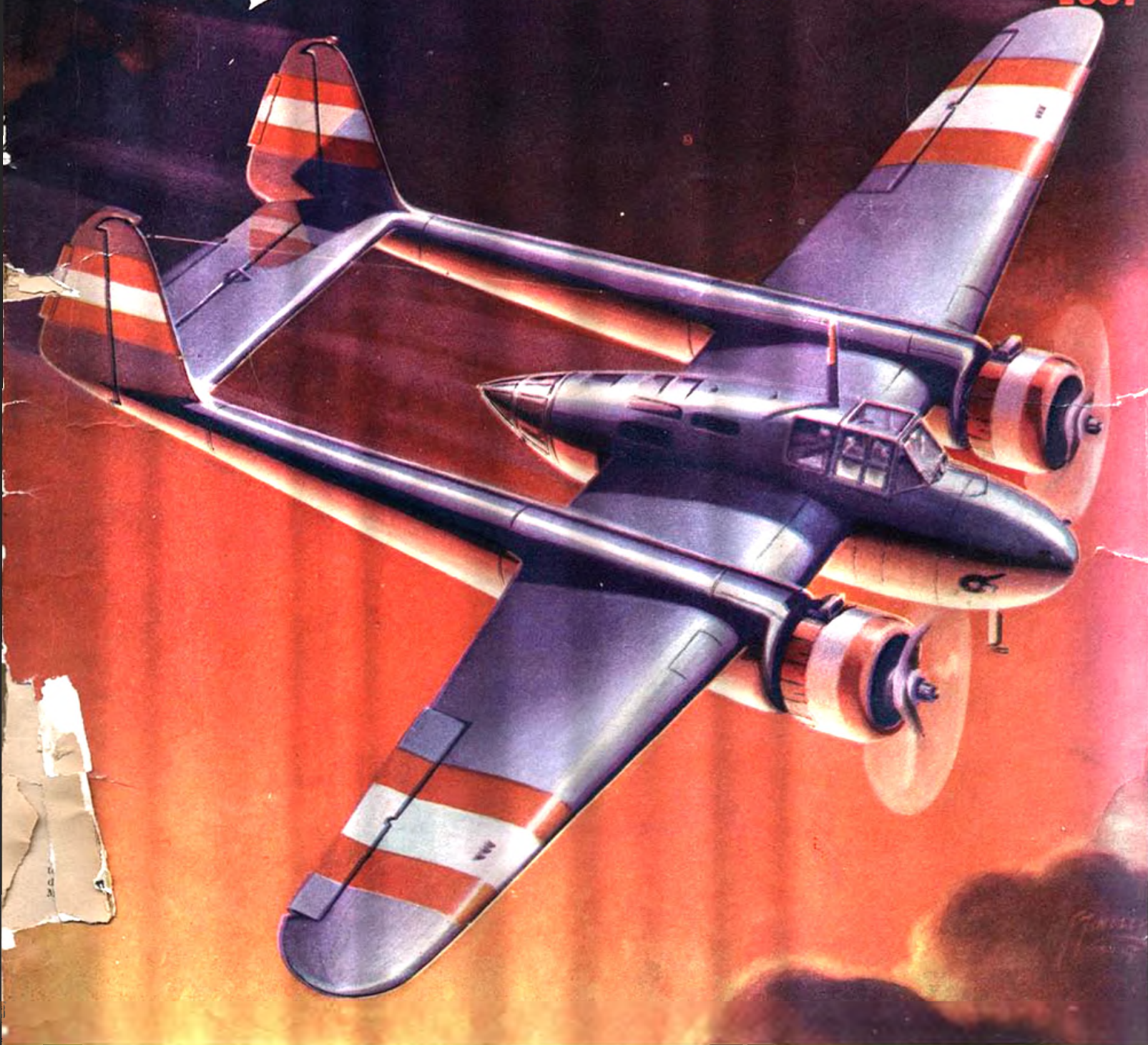

**IN THIS ISSUE:**

★ CLYDE PANGBORN   ★ Lieut. W. M. WOOD   ★ A. N. TROSHKIN   ★ ARCH WHITEHOUSE  
★ C. B. COLBY   ★ FRANK TINSLEY   ★ GORDON LIGHT   ★ ALAN BOOTON   ★ WM. WINTY

# IF MEN WORE PRICE TAGS



## HOW WOULD YOU FEEL?

● WELL, your boss thinks of you in terms of so much a week! You are worth this or that to him. How much you are worth depends upon—YOU! You decide the amount chiefly by your ability—by your training. Why not increase the amount by increasing your training? Thousands of men have done it by spare-time study of I. C. S. Courses. You are invited to earn more money. Mail this coupon.

### INTERNATIONAL CORRESPONDENCE SCHOOLS

BOX 4932-B, SCRANTON, PENNA.

★ Without cost or obligation, please send me a copy of your booklet, "Who Wins and Why," and full particulars about the subject *before* which I have marked X: ★

#### TECHNICAL AND INDUSTRIAL COURSES

- |   |   |  |  |  |   |
|---|---|--|--|--|---|
| <input type="checkbox"/> Architect                | <input type="checkbox"/> Telegraph Engineer       | <input type="checkbox"/> Radio               | <input type="checkbox"/> Welding, Electric and Gas | <input type="checkbox"/> Bridge Engineer             | <input type="checkbox"/> Chemistry            |
| <input type="checkbox"/> Architectural Draftsman  | <input type="checkbox"/> Telephone Work           | <input type="checkbox"/> Mechanical Engineer | <input type="checkbox"/> Diesel Engine             | <input type="checkbox"/> Bridge and Building Foreman | <input type="checkbox"/> Pharmacy             |
| <input type="checkbox"/> Building Estimating      | <input type="checkbox"/> Mechanical Draftsman     | <input type="checkbox"/> Machinist           | <input type="checkbox"/> Aviation Engineer         | <input type="checkbox"/> Highway Engineer            | <input type="checkbox"/> Automobile Mechanic  |
| <input type="checkbox"/> Contractor and Builder   | <input type="checkbox"/> Patternmaker             | <input type="checkbox"/> Toolmaker           | <input type="checkbox"/> Plumbing                  | <input type="checkbox"/> Civil Engineer              | <input type="checkbox"/> Coal Mining          |
| <input type="checkbox"/> Structural Draftsman     | <input type="checkbox"/> Heat Treatment of Metals | <input type="checkbox"/> Foundry Practice    | <input type="checkbox"/> Heating                   | <input type="checkbox"/> Surveying and Mapping       | <input type="checkbox"/> Navigation           |
| <input type="checkbox"/> Structural Engineer      | <input type="checkbox"/> Reading Shop Blueprints  | <input type="checkbox"/> Sheet Metal Worker  | <input type="checkbox"/> Air Condi.                | <input type="checkbox"/> Refrigeration               | <input type="checkbox"/> Cotton Manufacturing |
| <input type="checkbox"/> Management of Inventions | <input type="checkbox"/> Sheet Metal Worker       | <input type="checkbox"/> Boilermaker         | <input type="checkbox"/> Steam Eng.                | <input type="checkbox"/> R. R. Locomotives           | <input type="checkbox"/> Woolen Manufacturing |
| <input type="checkbox"/> Electrical Engineer      | <input type="checkbox"/> Electric Lighting        |  | <input type="checkbox"/> Marine Eng.               | <input type="checkbox"/> R. R. Section Foreman       | <input type="checkbox"/> Fruit Growing        |
| <input type="checkbox"/> Electric Lighting        |   |  |  | <input type="checkbox"/> Air Brakes                  | <input type="checkbox"/> R. R. Signalmen      |
|   |   |  |  |  | <input type="checkbox"/> Poultry Farming      |

#### BUSINESS TRAINING COURSES

- |  |   |                                      |  |
|--|---|--------------------------------------|--|
| <input type="checkbox"/> Business Management   | <input type="checkbox"/> G. P. Accountant | <input type="checkbox"/> Advertising | <input type="checkbox"/> Civil Service         |
| <input type="checkbox"/> Industrial Management | <input type="checkbox"/> Bookkeeping      | <input type="checkbox"/> Salesman    | <input type="checkbox"/> Mail Carrier          |
| <input type="checkbox"/> Traffic Management    | <input type="checkbox"/> Secretarial Work | <input type="checkbox"/> Service S.  | <input type="checkbox"/> Railway Mail Clerk    |
| <input type="checkbox"/> Accountancy           | <input type="checkbox"/> Spanish          | <input type="checkbox"/> Business C. | <input type="checkbox"/> Grade School Subjects |
| <input type="checkbox"/> Cost Accountant       | <input type="checkbox"/> French           | <input type="checkbox"/> Stenography | <input type="checkbox"/> High School Subjects  |

#### DOMESTIC SCIENCE COURSES

- |   |  |
|---|--|
| <input type="checkbox"/> Professional Dressmaking and Designing | <input type="checkbox"/> Tea Room and Cafeteria Management, Catering |
| <input type="checkbox"/> Home Dressmaking                       | <input type="checkbox"/> Millinery                                   |
| <input type="checkbox"/> Advanced Dressmaking                   | <input type="checkbox"/> Foods and Cookery                           |

Name..... Age..... Address.....  
 City..... State..... Present Position.....

If you reside in Canada, send this coupon to the International Correspondence Schools Canadian, Limited, Montreal, Canada

# AIR TRAILS

Reg. U. S. Pat. Off.

A STREET & SMITH PUBLICATION

## CONTENTS

### 3 Stories:

- BILL BARNES AIR NOVEL:**  
**DEATH RIDES THE SKY** 8  
*Men halted and fell beneath the diving planes—though no bombs were dropped. It was uncanny, devilish—and Bill Barnes faced the most baffling mystery alone.*  
*by George L. Eaton*
- The Flaming Finish** by A. R. Elrod 20  
*It was nip and tuck with the fire god—but he rounded the pylon before his motor conked—*
- "Dear Harry—"** by George Swift 28  
*Letters of an air student to his friend.*

### 13 Model Building Items:

- The Model Workshop**  
*Conducted by Gordon S. Light* 41
- The Contest Calendar** . . . . . 41  
*A schedule of competitive events.*
- The Mulvihill Winner**  
*by Bruce Luckett and Gordon S. Light* 42  
*A championship stick model for the contest builder.*
- Model Matters** . . . . . 46  
*Contests, club notes, model activities. This is your page. Use it.*
- The Fokker G-1** by Alan D. Booton 48  
*A double-fuselage flying scale model of unusual interest—the plane on the cover.*
- The ? Mark** . . . . . 53  
*Answers to your questions; information for all.*
- Double-surfaced Indoor Tractor**  
*by Lawrence N. Smithline* 54  
*An experimental model.*
- The Discussion Corner** . . . . . 56  
*This month readers discuss color visibility.*
- Builder's Guide** by William Winter 57  
*Enlargement of drawings—the fourth in the construction series.*
- Miles Mohawk** by William Winter 58  
*Solid scale model of Colonel Lindbergh's new hybrid.*
- Designing for the 1937 Wakefield Rules**  
*by Gordon S. Light* 60
- The Seversky P-35** by Paul Plecan 64  
*A solid scale of the newest army fighter.*
- Export Fighter** . . . . . 64  
*Another tempting solid scale model for the builders.*

### 8 Features:

- This Winged World** . . . . . 4  
*The best news photos of the air.*
- Air Progress** . . . . . 7  
*What's happening in aviation.*
- Seaplane Development** . . . . . 15  
*A page of pictorial instruction.*
- The Flier's Dictionary** by C. B. Colby 23  
*The nineteenth lesson in the technical terminology of the air.*
- Pictorial History of Man in the Air** . 27  
*More items for your aeronautical scrapbook.*
- Split-second Action** . . . . . 29  
*Aerial adventures that come once in a lifetime.*
- Cross Winds** . . . . . 39  
*The Air Trails Crossword Puzzle page.*
- Air Trails Gallery** . . . . . 40  
*Pictures of modern airplanes for the collector.*

### 5 Articles:

- Getting into Aviation**  
*by Clyde Pangborn and Lt. W. M. Wood* 16  
*The second article in a series which answers all your questions about opportunities in the air.*
- Take It Around** . by Frank Kurtz 24  
*The story of a boy who wanted to fly—and did!*
- The Reaper** . by Frank Tinsley 30  
*Mars gets a new sword—the plane on the cover.*
- Modern Motors**  
*by Arch Whitehouse and A. N. Troshkin* 32  
*The third article in a valuable series—the radial engine.*
- Tragic Memorial**  
*by Lt. Com. George O. Noville* 38  
*The story of an airplane cemetery.*

### 2 Departments:

- What's Your Question?**  
*Conducted by Clyde Pangborn* 35  
*A page of expert information for Air Trails readers.*
- Air Adventurers Club**  
*Conducted by Albert J. Carlson* 36  
*More news of our new, expanding activities.*

Single Copy, 15 Cents

Yearly Subscription, \$1.50

The entire contents of this magazine are protected by copyright, and must not be reprinted without the publishers' permission.

Monthly publication issued by Street & Smith Publications, Inc., 79-89 Seventh Avenue, New York, N. Y. George C. Smith, Jr., President; Ormond V. Gould, Vice President and Treasurer; Artemus Holmes, Vice President and Secretary; Clarence E. Verman, Vice President. Copyright, 1937, by Street & Smith Publications, Inc., New York. Copyright, 1937, by Street & Smith Publications, Inc., Great Britain. Entered as Second-class Matter, January 11, 1937, at the Post Office at New York, N. Y., under Act of Congress of March 3, 1879. Subscriptions to Cuba, Dom. Republic, Haiti, Spain, Central and South American Countries except The Guianas and British Honduras, \$1.75 per year. To all other Foreign Countries, including The Guianas and British Honduras, \$2.25 per year. We do not accept responsibility for the return of unsolicited manuscripts.

To facilitate handling, the author should inclose a self-addressed envelope with the requisite postage attached.

STREET & SMITH PUBLICATIONS, INC.

79 7th AVENUE, NEW YORK, N. Y.

# Prepare Quickly at Home in Spare Time

FOR A  
**Good Pay Job**  
 IN THE  
**Fast-Growing**  
**AVIATION**  
**INDUSTRY**



**WALTER HINTON:** trail blazer, pioneer, explorer, author, instructor, AVIATOR. The first man to pilot a plane across the Atlantic, the famous NC-4, and the first to fly from North to South America. The man who was a crack flying instructor for the Navy during the War; who today is training far-sighted men for Aviation. Hinton is ready to train you at home in your spare time. Get his book. Listen to what he has to say. He brings you real opportunity to get into Aviation and cash in on its big future.

**My famous course trains you right in your own home—gets you ready for one of the good ground jobs—or cuts many weeks and many dollars from flight instructions. Send for my big free book today.**

Don't sit back and envy the men who are in the midst of the romance, adventure and fascination of Aviation. YOU DON'T HAVE TO. For right in your own home, in your spare time, I'll give you the training you need to get started in this growing, well paid industry. Send for my FREE BOOK. It tells all the facts.

**Many Make \$40, \$60, \$75 a Week**

Yes, sir. Through the simple method I have worked out, I can train you at home to fill many well-paid jobs in Aviation. Naturally, before you can fly, you have to have additional flying instruction and practice. Even on that instruction I save you time and money. But when you graduate from my course you have the necessary foundation to begin such work as Airport Manager, Metal Worker, Assembler, Wing Doper, Transport Worker, Welder, Instrument Maker, Inspector, Wood Worker, Airport Worker, Mechanic, and scores of other well-paid positions. Some of my graduates have landed jobs paying \$40, \$60 to \$75 a week. Others, with the additional low-cost flying instruction I arrange for, have become pilots at \$300 a month or better. Send for my free book now and get the interesting particulars. Learn how I fit you to fill a good job in Aviation.

**You Have Many Types of Jobs to Choose From**

This simple, fascinating, easy-to-learn course actually covers the ground so thoroughly, that my graduates now fill many types of Aviation jobs. At good salaries, too. Read the list of jobs in the center of this page. Check them over carefully. Then remember that they are but a few of the many jobs that Aviation offers the trained man.

**Aviation Is Growing Fast**

Get into Aviation now—when you can still get in on the ground floor of a new industry—when you have a chance to forge ahead without having to displace lots of older men. Aviation is a young industry, where young men earn real money. Most famous pilots are in their early thirties, or even younger. It is a young man's industry, which means that there are plenty of opportunities to forge ahead. But just because it is run by young men, don't get the idea that Aviation is a small business. Millions are being spent yearly to develop and improve

Here are just a few of the many well-paid jobs in the fast growing Aviation Industry

**ON THE GROUND**

Airport Superintendent	Purchasing Agent
Instrument Specialist	Aerial Mail Clerk
Electrician	Motor Expert
Shop Foreman	Radio Operator
Hangar Crew Chief	Airplane Mechanic
Traffic Manager	Field Work

**IN THE AIR**

Air Express Agent	Private Piloting
Air Mail Pilot	Weather Observer
Aerial Photography	Flight Instructor
Airport Manager	Commercial Pilot
Test Pilot	Field Manager
Aerial Passenger Agent	Transport Pilot

**My Training is Thorough, Practical, Up-To-Date**

I've put my eighteen years of experience—including five years of instructing officers and men in the Navy—into my thorough, quick training. And I've made it all so clear that almost anybody can understand it. My Aviation friends know that Hinton-trained men are well qualified to work for them.

**Send for My Free Book Now**

Now is the time to act. Don't sit content with a hum-drum, no future, low-pay job. Act now—to get yourself into Aviation—the industry that is quickly growing into a giant business. Get into Aviation. Study at home in your spare time for a well-paid job with a real future. Mail the coupon for my free book today.

Walter Hinton, Pres.  
 Aviation Institute of America, Inc.  
 Washington, D. C.



airways and planes. Thousands of men earn good livings from the business. And thousands will enter it in the future. It is a great and growing industry, this Aviation, an industry that still brings romance, excitement, thrills—even while it is bringing big opportunities and good pay.

**FLIGHT INCLUDED**

"Give her the gun!" You're off! Yes, sir, as soon as you complete my course, I arrange a free flight for you at an accredited air field. It doesn't cost you a penny extra. It is my graduation present to you.

**Mail for my big FREE BOOK on AVIATION NOW!**

**These Men Made Good With My Training**

**Accepted for Royal Canadian Air Force**

"I sent your letter with an application for enlistment in the Royal Canadian Air Force and I received a letter stating that my application is accepted and I can enlist as soon as there is a vacancy." JOSEPH J. BEINIG, Melville, Sask., Canada.

**Perfectly Satisfied With Course**

"I am perfectly satisfied that the results obtained to date from your course have made its cost insignificant. Rest assured that you have a life-long booster for Aviation Institute training." L. W. ARCHER, P. O. Box 58, Curacao, D. W. I.

**Mr. Walter Hinton, President**  
**Aviation Institute of America, Inc.**  
 1115 Connecticut Avenue, Washington, D. C.

Please send me a Free copy of your book, "Wings of Opportunity," telling all about my opportunities in Aviation and how you will train me at home for them.

Name .....  
 (Print clearly)

Address ..... Age .....

City ..... State .....

# This Winged World



Whirling blades of the constant speed propeller viewed from a cabin window of the China Clipper during a trans-Pacific flight. This type propeller automatically selects the blade pitch best suited for efficient operation at a constant engine speed.



Above—New English ground trainer fitted with conventional wings, permitting the student to fly at a restricted height once he has grasped the essentials, reduces the cost of flight training. Left—In flight the trainer affords the student actual operating experiences.



Above—Nonchalant is Harold Parkhurst, daredevil parachute jumper, as he lights cigarette while falling from 5,000 feet.



Radio direction finder newly developed, pointed to by hand in picture, enables pilots to quickly determine position by obtaining bearings on two radio stations.



Interior of one of the new extra-fare, luxury airliners recently placed in service by United Airlines on their New York to Chicago run. By seating 14 passengers instead of the usual 21, it was possible to utilize deeply upholstered, club-car-type swivel chairs.

Hull of the 18-ton British flying boat "Cavalier," being drawn up on the beach at Bermuda preparatory to assembly. The "Cavalier" is one of a number of flying boats intended for trans-Atlantic service in the spring.

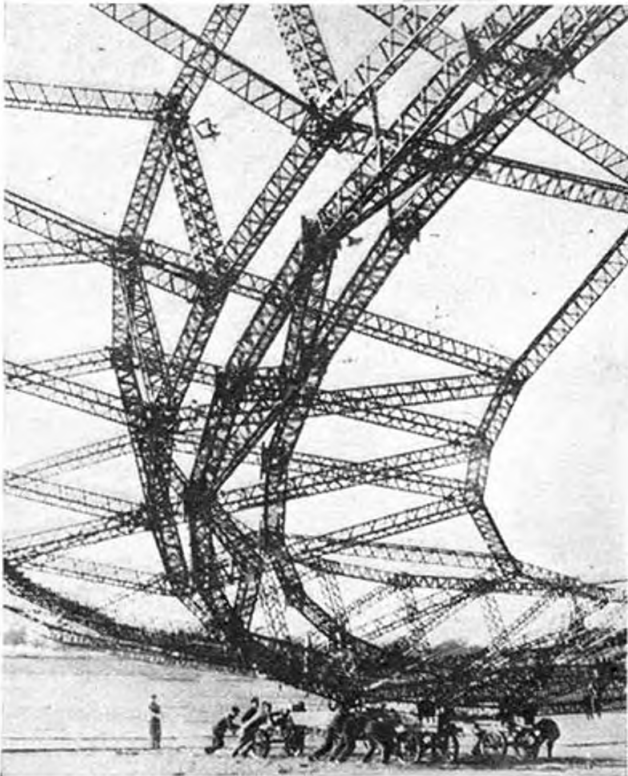

Section of new German Zeppelin now under construction, being moved into position by workmen, indicates the hugeness of its complex framework.

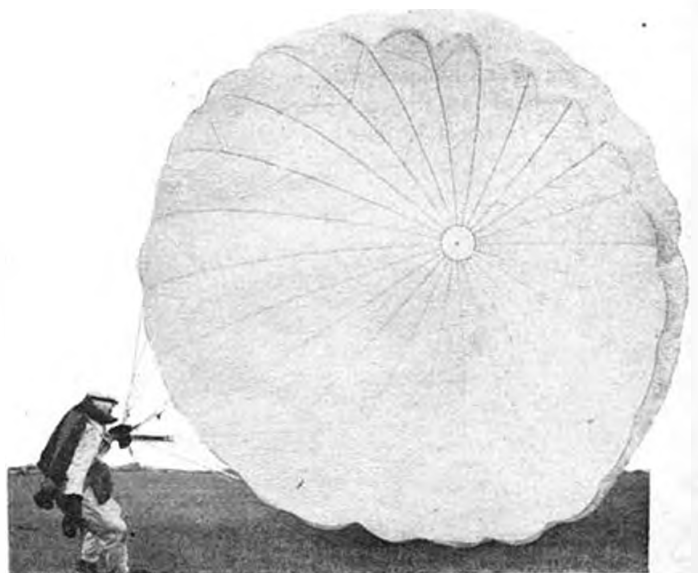

Gwyne John, English parachute jumper, shown after practice jump, intends falling 18,000 feet before pulling the rip cord.

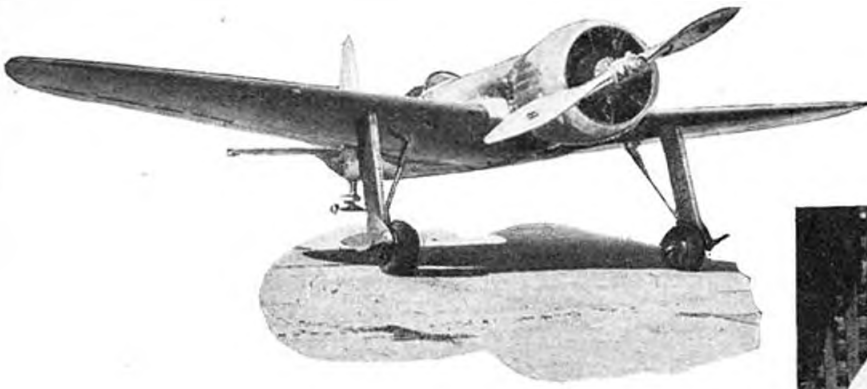

The "Winged Bullet," Howard Hughes' famous racer, at Newark after its trans-continental record dash of less than eight hours.

Below—Reforestry plane is one of several former mail planes now used by the government to scatter seeds upon burned-over forest land.



Right—This primary glider, in flight on a mid-winter day in England, exemplifies the popularity of the sport in that country.



Above—Safety device which, when attached to the inlet and outlet of a tank, reduces the danger of gasoline explosion to a minimum.

(Inset) Left—Closeup of the funnel-shaped inlet that contains the fire-prevention screen.

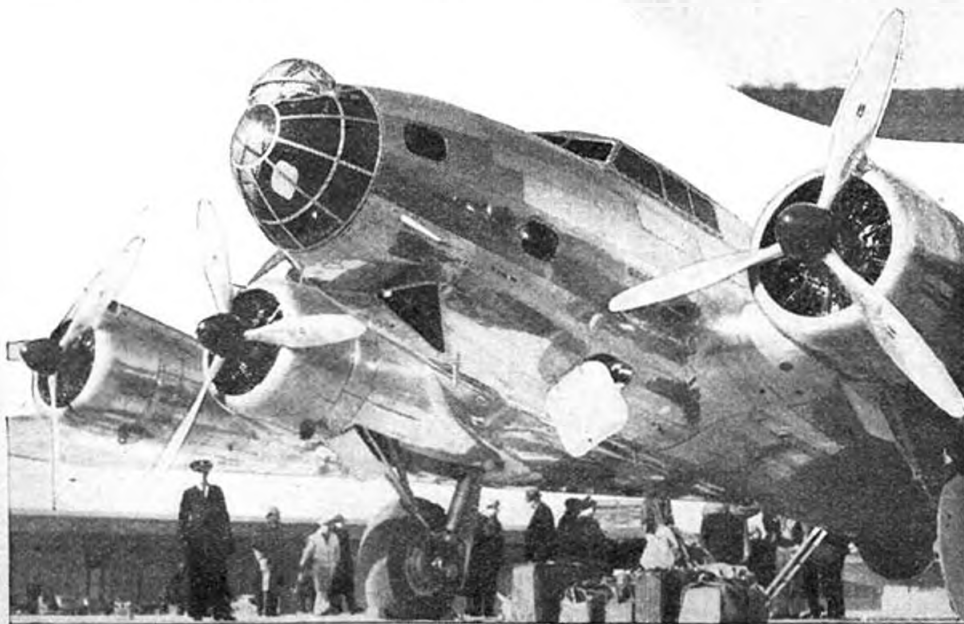
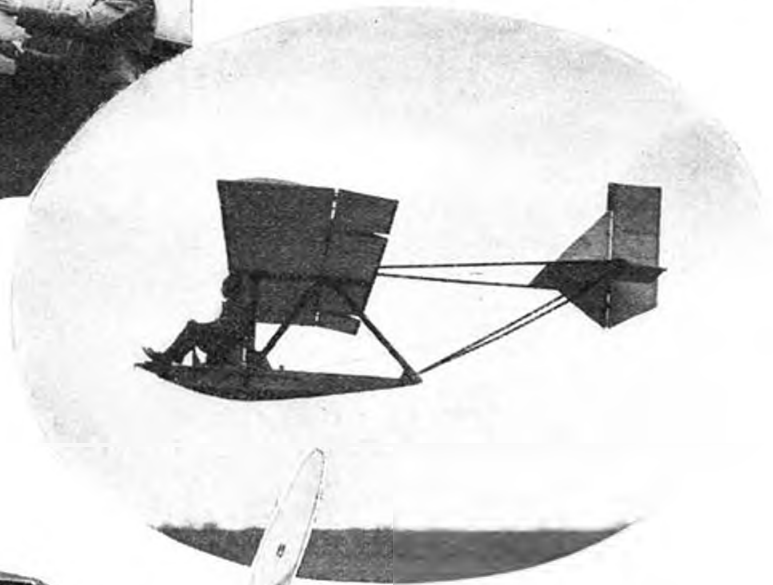

Closeup of the Boeing bomber illustrates the revolving turret in the nose, the great engine nacelles, and the method of retracting the landing gear which has wheels almost as high as a man is tall.

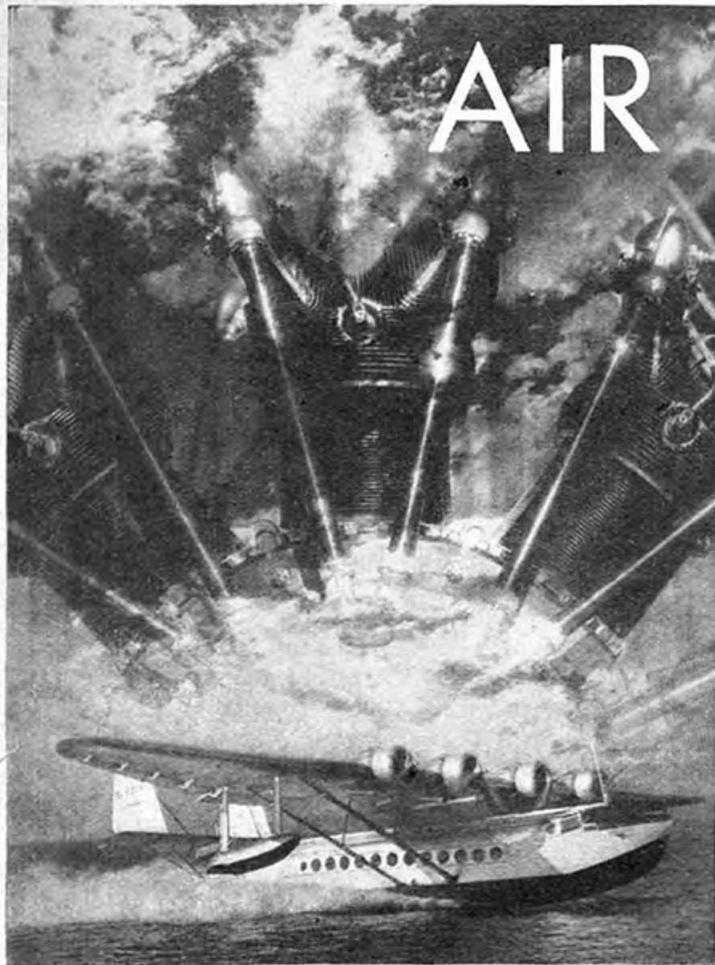

Sikorsky S-42-A Clipper super-imposed over a Pratt & Whitney engine and clouds.

## TRANSPORT

**F**OR A PREMIUM of \$2.00 one may now fly between Chicago and New York via United Air Lines Skylounge Douglas transports. Passengers using this de luxe service get overstuffed swivel chairs and Pullman-car luxury.

Pan-American Airways recently disclosed that they had signed a mail contract with the British Colonial Government at Hong Kong for the shipment of trans-Pacific mails. The arrangement was completed when it was disclosed that Pan-American had established a Manila-Hong Kong leg of the United States to China air line.

Senator Hattie W. Caraway of Arkansas recently proposed that commercial air lines be required to provide a parachute for each passenger. Representative D. Lane Powers of New Jersey introduced a similar measure in the House.

Dr. John B. Crane, of Harvard University, is not certain that the Wright Brothers were America's first heavier-than-air pilots. He has seen reliable evidence that Gustave Whitehead, a former Bridgeport night watchman, actually attained mechanical flight along the streets of Bridgeport as early as 1900. One witness swears that Whitehead flew one and one half miles on August 14, 1901, or more than two years before the Wrights made their first flight. Whitehead died in obscurity in 1927.

During 1935 Canadian Airways, Ltd., flew 674,018

# Progress

## A Summary of AVIATION NEWS

miles and carried 14,540 passengers. Lord Beaverbrook, noted British newspaper publisher, has ordered a new American Lockheed which has a top speed of 230 m.p.h. The first trans-Canada air service is scheduled to start on July 1st.

The new British Armstrong-Whitworth airliners, being built for Imperial Airways, will be known as Ensign ships. The Brussels First International Aircraft Exhibition is set for May 26th to June 6th, and it is understood that many American models will be on view.

An interesting item brought out during the investigations of air crashes in the West recently disclosed that vast deposits of radio-active ore on the air-line route over Newhall Pass may have been responsible for two plane crashes in that area. Radio-beam communication aboard both doomed liners was possibly affected by millions of tons of uranium, a radium-filled mineral lying just below the surface of the Newhall hills, explained Charles Slattery, a veteran engineer.

Pan-American Airways has been notified by the Brazilian government that after 1938 planes flying over Brazil on commercial routes must be piloted by naturalized citizens or native Brazilians. Mexico passed a similar ruling last year.

## AIR FORCES

Japan recently drafted a new armament program which included \$21,074,863 for strengthening the naval air service. \$7,525,483 will be spent during 1937 and an additional \$2,697,537 for the increase in the cost of aircraft maintenance.

It has been reported that the U. S. army air service will carry out a mass trans-Atlantic flight to London, in connection with the coronation ceremonies of King George VI.

The Canadian Car and Foundry Co. has obtained manufacturing license rights to the Grumman FFE two-seater fighter, in Canada. Howard F. Klein recently broke Frank Hawks' old mark between Roosevelt Field and Montreal in one of these ships, covering the distance in 1 hour and 40 minutes. Hawks' old mark was 1 hour 57 minutes.

It has been stated that the German air service boasts of 7,000 machines-of various types and her aircraft production plans call for at least 10,000 planes a year. At the Junkers plant in Dessau more than 25,000 workers are employed.

The new North American O-47 observation monoplane has transparent panels in the fuselage belly for the observer.

New Zealand readers will be glad (Turn to page 95)



# DEATH RIDES the

**E**VERYWHERE MEN were in action: engine mechanics, machinists, field-traffic men, dispatchers, radio inspectors, porters, and passengers. A voice blared eerily through the loud-speakers.

"Plane leaving in five minutes for Elko, Reno, Sacramento, San Francisco, and Oakland. Please give your baggage to a porter to be weighed and put aboard."

Passengers filed through the waiting room to have their tickets registered and stood waiting inside the gates ready to go aboard the big, twin-motored transport plane that stood at the end of the gayly colored canopy.

There was intense excitement in the air. It crept under people's skins and brought a flush to their cheeks and sometimes a ripple of aimless, senseless laughter to their lips. Passengers and their friends and families stood gazing through the gates at the enormous monster pulsating on the concrete runway. Tears and laughter intermingled as the sun plunged into its bed behind the mountains to the west.

Mechanics hurried carefully through their last-minute tests; porters stowed baggage away in the side of the plane. Back in the terminal building inspectors worked on weight charts, to make sure the combined load of passengers, baggage, mail, and express did not exceed the maximum weight allowed by the department of commerce. Teletype machines rattled away, notifying every station ahead that Flight No. 7 was about to take off, warning them to stand by and report as the big ship passed overhead.

A bride of four weeks kissed her husband good-by; a mother kissed her only daughter good-by; a grandmother was giving instructions to a porter about the two twelve-year-old children who were going home alone.

Young Jimmie Murphy, the co-pilot of the big ship, had already warmed up the two geared, supercharged Falcon engines.

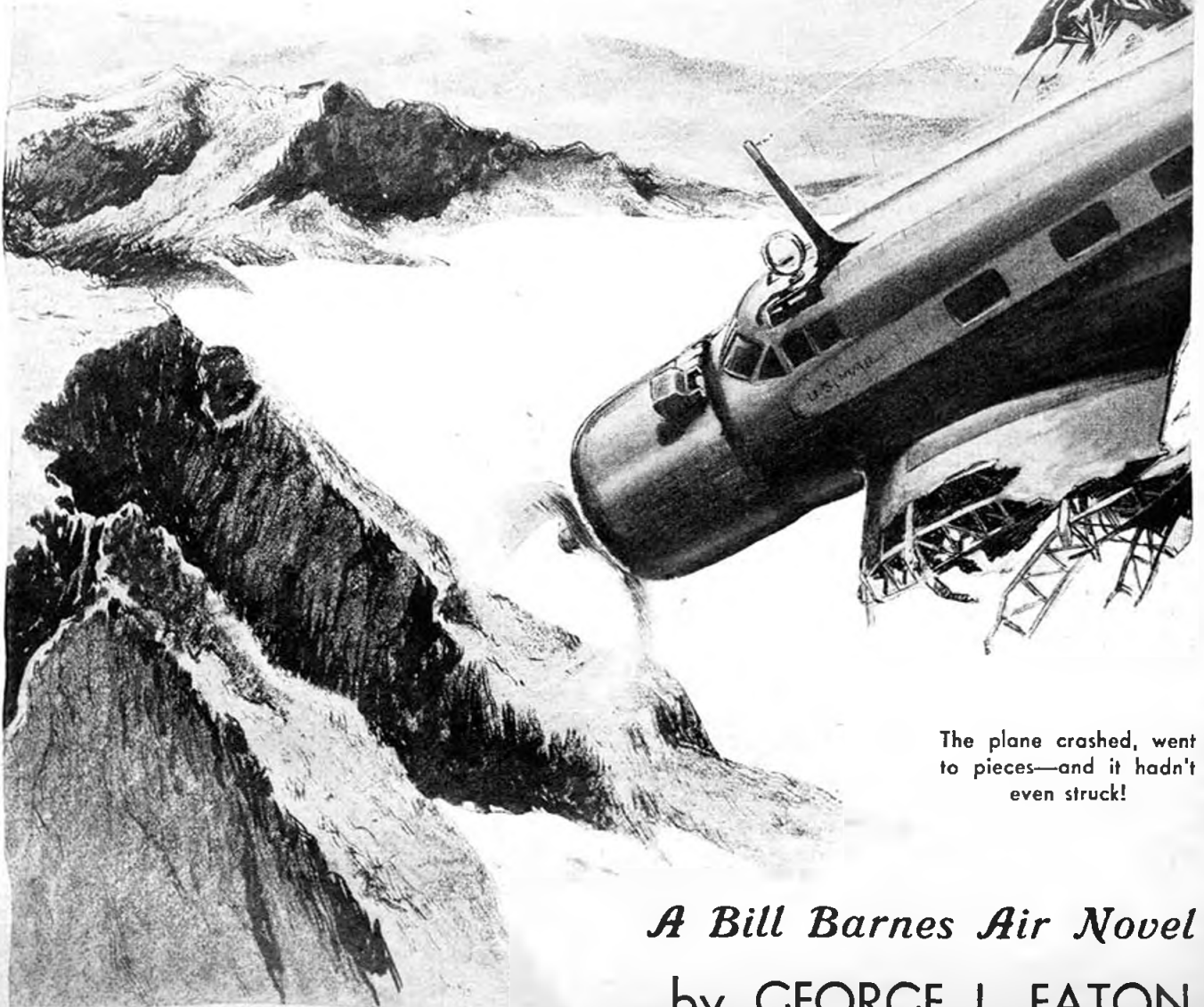

The plane crashed, went to pieces—and it hadn't even struck!

*A Bill Barnes Air Novel*  
by GEORGE L. EATON

# SKY

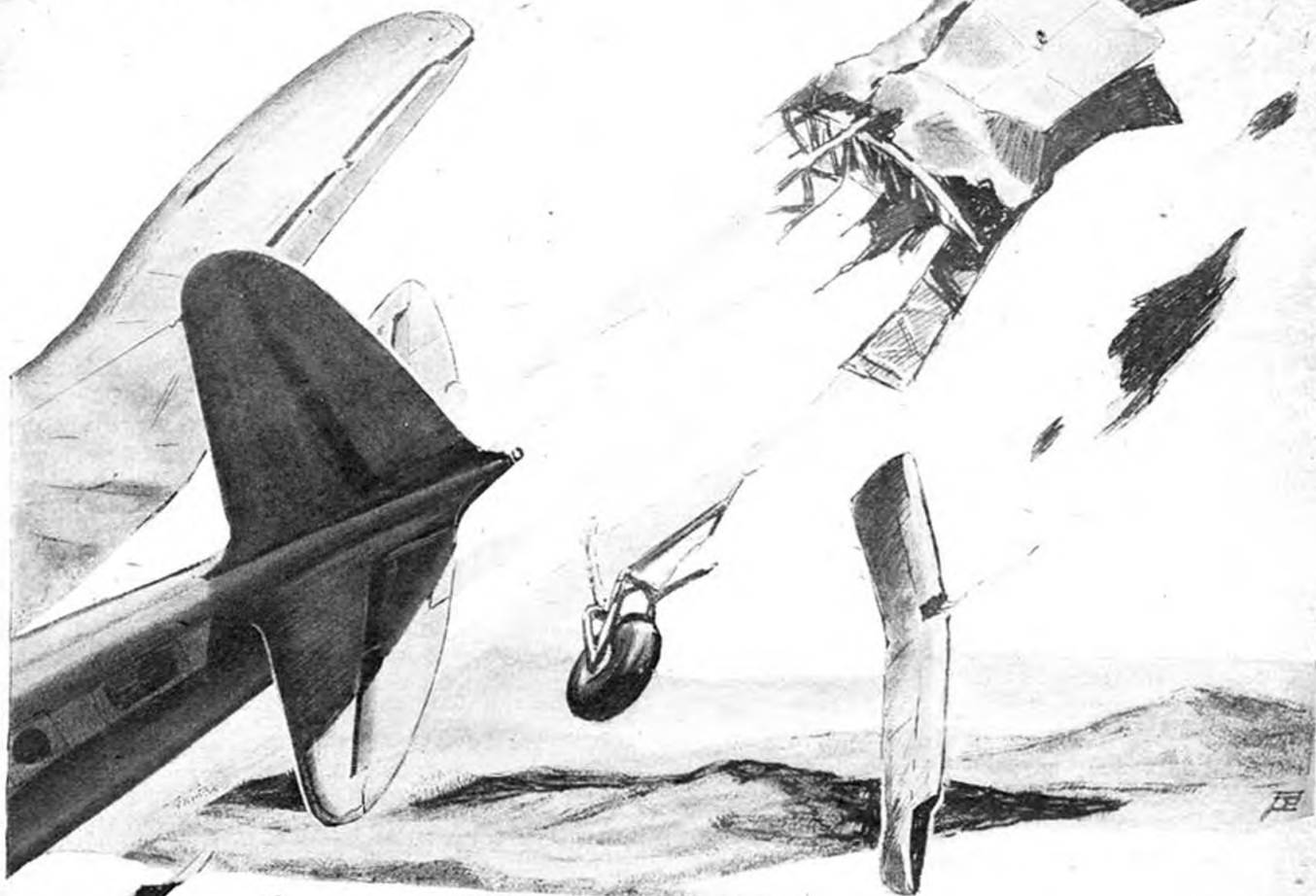

*A voice yelled through the phone,  
"If you can't stop it, Barnes, every  
plane in the service will be grounded."*

The two idling propellers were shining disks in the dimming light of the late afternoon.

As Martin Dewart, the skipper, entered the pilot's compartment with his bag of registered mail, young Jimmie turned and grinned at him.

"How was the kid to-day?" he asked.

Martin shook his graying head. "He's out of danger now," he said. "The doctor says its just a matter of care and rest from now on." He stopped speaking as his voice broke for a moment. "You know, Jimmie," he said in a moment, "I don't know what I ever would have done if anything had happened to that boy of mine. He is so little and so helpless. My wife and I——" He stopped speaking because he couldn't go on.

Young Jimmie Murphy leaned over and gave him a slap on the back. "It's over now, skipper," he said. "Go on and cry like a baby if you want to. I understand. You kept your chin up for three frightful weeks."

The stewardess, a brown-eyed, trim little figure in her jaunty uniform, came down the runway and stuck her head in the pilot's compartment.

"How's Timmy?" she asked the skipper.

Martin Dewart turned and smiled at her. "He's O. K. now, Peggy," he said. "He's going to pull through. He's tough like his old man."

"His old man isn't so tough when Timmy gets sick," Peggy Axton said, without thinking. "And he wouldn't be so tough if anything happened to you."

Martin Dewart's head flew up and he gazed at the stewardess with startled eyes. She flushed as she realized what she had said, and went hurrying down the runway to meet the oncoming passengers.

She stood beside the small portable steps which led up and in through the oval-shaped metal door to the cabin. The passengers exclaimed over the soft, rich fabrics on the walls and the daintily curtained windows.

Peggy Axton assigned them to the deep-cushioned, single seats arranged in rows beside the windows, and showed them how to adjust their safety belts when the ship took off.

Martin Dewart swung around in his bucket seat as the eighteen passengers came aboard. He studied them

carefully as they took their seats to right and left. He liked to know what kind of people he was carrying, because he was responsible for them. A couple of times he had refused to take his ship aloft until men who had had too much to drink were taken off. Flying was a serious business with Dewart.

He gunned his engines as the stewardess flashed a "Please Fasten Seat Belts" sign over the forward door. He listened for a moment to their muted roar, while his eyes scanned his instrument panel.

He idled the motors down and waited for his take-off signal from the dispatch tower. A moment later he taxied across to the runway that gave him the longest run into the wind. A white signal light flashed that all was clear, as a dispatcher scanned the air and Dewart gave her the gun. He took the ship to ten thousand feet, where he leveled off and adjusted his throttles to a cruising speed of one hundred and eighty miles an hour.

As night settled upon them Jimmie Murphy picked up the radio transmitter, pressed a button and chanted: "Trip No. 7. Trip No. 7 calling Station WVBD—WVBD."

"WVBD. This is Station WVBD. Calling Trip No. 7. Go ahead!" came back to his ears.

"What is the wind surface? What is the wind surface?" Jimmie wanted to know.

"WVBD to Trip No. 7. Surface wind WSW. Surface wind WSW ten one zero. Go ahead! Go ahead!" the ground sent back.

The stewardess flashed a light that read: "Passengers May Unloose Their Safety Belts." Then she took a tray of sandwiches, wrapped in cellophane, and hot bouillon, coffee, tea, and fruit down the runway. The passengers settled back in their seats and found that they could eat.

She flashed another sign that said they could now smoke. They settled down, all their nervousness gone. The soft, quiet swaying of the big ship lulled some of them to sleep. Some of them were laughing and chatting gayly.

Far below, in the darkness, the mountains spread out like an unending sea. But the passengers knew that Martin Dewart did not need eyes to see. The better-informed ones knew that he had a magnetic compass which showed him north at all times; a gyro compass, whose axis is free to turn in any direction, but so mounted that its absolute and unvarying direction was maintained. They knew he had an earth inductor compass, which had a generator which recorded the direction of flight of the plane; a controller which was set by the pilot according to the direction in which he wished to go, and the indicator, which would show any deflection from his intended course.

They knew he had a "bank-and-turn" indicator to show how much he was leaning to left or right as he turned; an altimeter that would show him just how high he was flying, and an air-speed indicator that would tell him how fast he was flying after deducting the speed of a head wind or adding the speed of a tail wind.

They knew he needed only the navigating instruments before him to take them safely through the night, and they were not nervous. With the exception of one old lady, who was riding in Seat No. 4 on the port side.

She was nervous and she didn't care who knew it. But she would have been just as nervous if she had been lying on her bed in her own home.

Martin Dewart was thinking about his kid, Timmy, as he held the ship steady above the high East Humboldt Range of mountains. In his ear was the constant hum from a long-range beacon down below, guiding him on his course as surely as a lighthouse guides a skipper at sea.

As long as he rode the "radio beam" and the interlocking signals A and N in the Morse code continued to sound in his ear, he was dead on his course. If he deviated to the left or port, a dot-dash, dot-dash would warn him, if to starboard he would hear a dash-dot, dash-dot, until he got back on the radio "track" the government stations broadcast along the airways.

He glanced at his altimeter and saw that he had ten thousand feet under him. Seven thousand was enough, but Skipper Dewart always played it safe. A fellow never could tell what the air currents above that range of mountains might do.

He began to think about Timmy and his wife again, and a warm glow suffused him. He decided he was a pretty lucky guy, after all. It wasn't everybody that had as sweet a wife and kid and a job that laid the money on the barrel head the way Amalgamated did it. He slid back his ear phones and spoke to Jimmie Murphy.

"You know," he said, "I'm going to stop crabbing about things. Here I have all kinds of things to be thankful for and I'm always going around lamenting like a man with coots in his beard. I——"

"Good!" Jimmie interrupted. "If you stop crabbing, I'll stop smoking opium!"

"There you go," Skipper Dewart said, "trying to be funny. Why don't you get some cork and do it with a black face. The trouble with you is——"

And then it happened!

The faces of the two pilots turned white as they felt the big ship being flicked by the finger of eternity. Their eyes sped to the altimeter. It read seven thousand feet. Dewart yanked back on the wheel with all of the strength in his powerful arms. At the same instant he knocked his head phone back on his ears and the two interlocking signals told him he was on his right course.

He moved with the speed and coordination for which transport pilots are famous. But he moved too late. There was a rending crash as the big ship sped into the side of a mountain at a speed of one hundred and eighty miles an hour.

As the lights went out and the big ship folded up like an accordion, the night was pierced by the horrible screams of the passengers.

There was that one tremendous crash and then a half hundred lesser ones, as the plane settled and the engines sobbed their last gasp.

Fire trickled out from the engine house and licked back, fanned by a devil's breeze. The flame reached a gas tank. The night was made hideous by the wailing sobs of passengers who had not yet died, as a tank exploded, then another, and another.

Three hours later silence settled down over the twisted thing that had been like a thing alive a few hours before.

Far away, a ground operator chanted into his microphone: "WVBD—WVBD calling Trip No. 7. Calling Trip No. 7."

## II—ANOTHER CRASH

HELL BROKE LOOSE along the mountain division of the Amalgamated Airways at three o'clock in the morning. The general manager, the division opera-

tion manager, the division engineer, the traffic manager, and the communications superintendent were routed from their sleep and knew the panic a dozing front-line trench knows when the enemy attacks at dawn.

The first editions of the metropolitan press throughout the United States carried large, black headlines of the missing Amalgamated transport. Later editions carried editorials. Columnists devoted half their columns to the missing plane.

When the public learned that Paul Mungo, the radio crooner who had held the country in the palm of his hand for years, and a senior United States senator were passengers aboard the missing plane, they took an interest they had never taken in the air lines before.

At daybreak Amalgamated Airways dispatched fast planes from all of the airports on the mountain division.



Just before the two ships crashed head-on, Bill pulled the stick back! The Lancer went roaring upward—

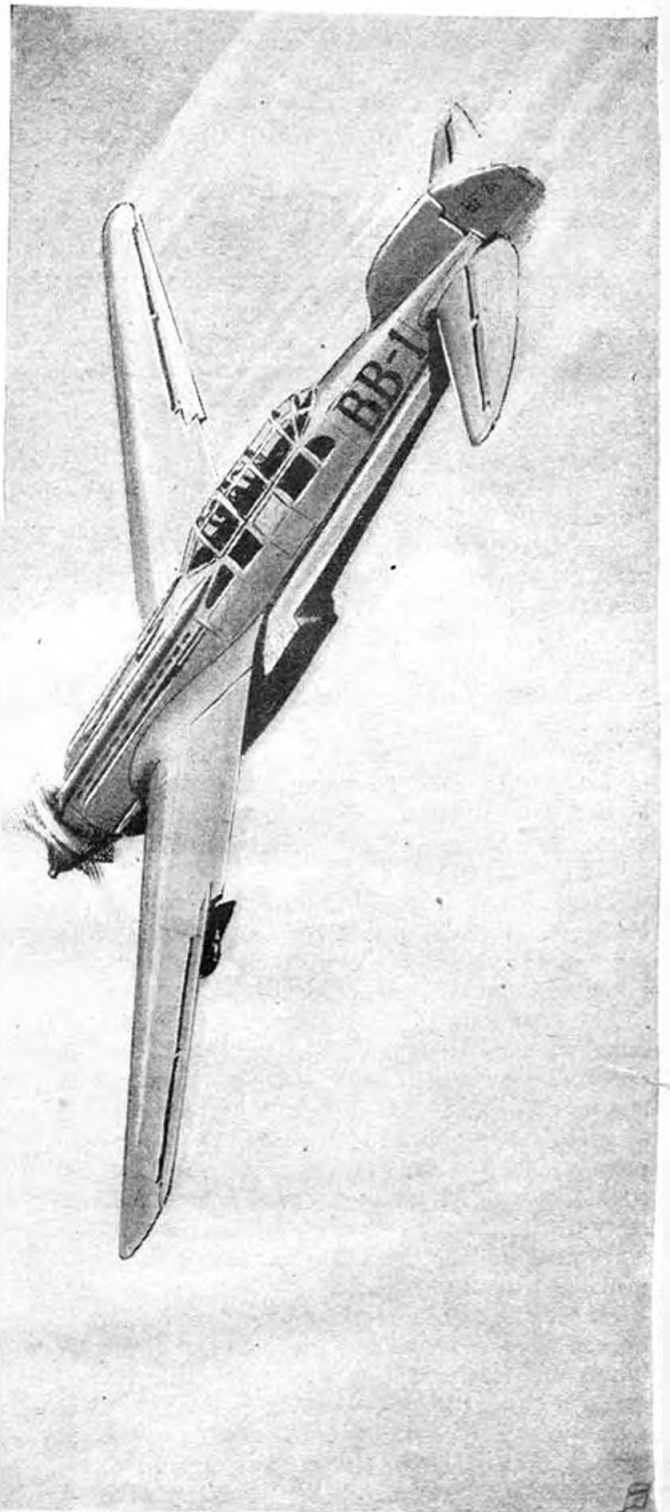

in search of the big transport. The army sent planes from as far east as Michigan and as far west as San Diego. They followed the regular route from Summit, Nevada to San Francisco, but found no trace of the missing plane.

But at nine o'clock in the morning Charlie Spencer, veteran Amalgamated pilot, and Burt Longnecker, traffic manager, located the tangled thing, that had been a transport plane, on the side of a mountain. It was fifty miles off its course.

When Burt Longnecker saw that horrible sight he buried his face in his hands. They flew low and saw that there were no signs of any one having left the plane after the crash. They knew that the passengers who

had not been killed in the actual crash had been locked inside the ship to be burned to a cinder. No one could possibly have survived.

"They were on their course, according to their reports," Longnecker whispered. "They reported right up to the time of the crash that they were riding the radio beam and everything was O. K."

"Everything wasn't O. K.," Charlie Spencer pointed out. "Everything wasn't O. K. or Marty Dewart wouldn't have stuck his nose into a mountain. Old Marty, of all people. He's one guy I'd have bet my last dollar would die in bed."

Congress, the department of commerce, the whole nation, clamored for an investigation. It was the third crash on the lines of Amalgamated Airways within eight months. They had all been on the route from New York to San Francisco, and they had cost a total of sixty-three lives.

The late-afternoon papers carried full pages of the wreck, taken by news photographers from the air. They carried pictures of Senator Gettier and of the two children who had been traveling alone.

Editorials struck a solemn note of warning that "The airways will lose the public's confidence if another such disaster occurs."

The five million women who had closed their eyes and listened to Paul Mungo croon to them became hysterical in their demands for some one's head. The husbands of most of them didn't say anything.

The five million men who had followed the tirades of the senator from Louisiana on the floor of the upper house wrote letters to the newspapers and demanded that he be avenged.

The chairman of the board of directors of Amalgamated Airways called a meeting of the directors in New York City. It was a worried and harassed little band of men who faced him around the long table. They saw a great enterprise crumbling beneath their very eyes. And, somehow, they felt guilty of having taken those sixty-three lives. They were a solemn, nervous lot of men as Benjamin Shipman, the chairman of the board got to his feet.

At precisely the same moment Shipman opened his lips to speak, a light flashed white in the traffic tower on the Amalgamated airport at Summit.

A dispatcher on the field signaled that the air was clear. The pilot of the single-motored, six-passenger Meredith transport kicked the ship around into the wind as he studied the windsock and the wind vane.

The co-pilot, a youngster of twenty-five, sealed the cabin door and went up into the pilot's compartment. It was a short hop from Summit to Denver, Colorado—that is, short compared to the long, transcontinental hops, and the plane carried no stewardess.

The pilot, Jerry Winsor, a veteran with a million flying miles behind him, and a great many hours, looked at the co-pilot, Ralph Parks, and shook his head.

"I'm as nervous as a cat on a red-hot stove," he said. "I can't believe old Marty has gone west. I never knew such a careful guy and such a marvelous pilot. It's got me down."

"Don't get down too far or you'll be stickin' our nose

in a mountain." Ralph Parks grinned. "I'm a young man an' I got a lot of things to look forward to."

Jerry Winsor looked at him in disgust. He was an old man, as pilots go. He was thirty-six.

"When we get in the air you take the wheel," he said.

"O. K.," Ralph said. He glanced over his shoulder at the six passengers. They were all, obviously, nervous. "Our flying guests don't look as though they had too much confidence in us," he said. "They've been readin' the papers."

Jerry Winsor "revved up" his single Falcon engine until it was turning over smoothly and beautifully. He threw off his wheel brakes and the streamlined ship raced down the runway into the wind. The tail came up and Jerry Winsor took it aloft in wide, sweeping spirals. He coaxed the powerful ship up and up, until he had fifteen thousand feet under him. The route he had to fly was one of the toughest in the country. It was fully as bad as that dangerous stretch over the Allegheny Mountains in Pennsylvania.

"All right, Bleriot," Jerry said to Ralph Parks, as he



threw him the wheel, "do your stuff."

The Falcon whirlwind engine droned on and on above the tips and crags and chasms of the mountains. At intervals the two pilots relieved one another at the controls and the radio.

Ralph Parks had the controls when he sighted Denver ahead and began a long glide toward the airport. It was miles away and they still had plenty of altitude when he pulled back on the controls and tried to lift the nose. He looked at Jerry Winsor out of the corner of his eyes, when the ship didn't respond, and tried again. Nothing happened. The nose began to drop too fast. His face was white when he spoke to Jerry as calmly as he could.

"There's something wrong, Jerry," he said. "She won't respond. It feels as though the flipper and rudder cables had gone."

Jerry Winsor stared at him as he signed off on the radio. Then he grabbed at his own wheel and began to curse. But the nose was down now and nothing that he could do would bring it up. He gunned his engine and tried to warp the plane up. The passengers in the back were getting out of their seats trying to get up the runway.

"Lock the door!" Jerry snapped at Ralph Parks. Ralph Parks locked the door from the cabin to the pilot's compartment, as three men crashed against it. Their faces were twisted into weird masks, and in their eyes was the fear of death. They bellowed like caged, angry animals as Jerry Winsor fought his ship with all the steady calm of a master pilot and a desperation born of necessity.

The sturdy ship was plummeting toward the earth at a terrific speed, when the wings tore off completely. The fuselage began to revolve as though some invisible

The board of directors of Amalgamated Airways was about to adjourn when Benjamin Shipman's secretary stepped into the board room and closed the door behind him. His face was white and his hands were trembling. The first time he tried to speak no sound came from his bloodless lips.

"You're wanted on the telephone, Mr. Shipman," he said. "Long distance. It's——"

"It's what, man?" Shipman bellowed at him. But he knew. An old axiom to the effect that "it never rains but it pours" flashed through his mind.

"It's the general manager of the mountain division, sir," his secretary said. "There has been another crash!"

### III—A PLOT

BILL BARNES ran his hand through his shock of blond hair and then wiped it on the chemist's apron he was wearing over his flying clothes. A little frown puckered his tanned forehead as his eyes wandered the length of the diminutive laboratory he had established on Barnes Field, Long Island. Then back to the figures



hand had the nose on a stick and was twirling it around. Jerry Winsor shut off the ignition and shouted above the sound of the racing gale that went by them, "Good-by, kid," and his lips were twisted into a smile.

Young Ralph Parks touched his uniform cap in a last salute, as the ship's engine drove into the ground and ripped back through the length of the fuselage.

There was not a sign of life amid that twisted and tangled mass of steel and wood when fire trucks, ambulances, and a wrecking crew arrived on the scene from Denver. One of the passengers was breathing, but he died before he reached a hospital. The rest were mangled beyond recognition.

before him. He checked and rechecked the formula for the new alloy of metals he was trying to develop. He knew that if he was successful he would have a formula for an alloy that would reduce the weight of aircraft by nearly half. The possibilities for long-distance flight would be tremendous. It would be a discovery that would be of inestimable value to the defense of the United States.

Feeling that he was getting closer and closer to a successful discovery, he had not left his laboratory since noon the day before. Old Charlie, the head cook on Barnes Field, had sent his meals to him on a tray. Most of the trays had gone back to the kitchen scarcely

touched. He had slept for two hours, sitting on a high stool with his head resting on his arms and his arms on a workbench.

His face was lined, his eyes red and swollen, and he was nearly exhausted from the absolute concentration of his job. He had told Tony Lamport, the chief radio operator and communications superintendent on Barnes Field, not to bother him under any circumstances. He had told young "Sandy" Sanders, his secretary and the youngest member of his little squadron of famous fliers, the same thing. He had been working alone for nearly twenty-four hours.

"C'mon seven!" he said, ruefully, as he gazed at the formula and snapped his fingers. "I've almost got you, baby. Get nice! Get hot! I'm going to crack you, so why not now?"

He climbed off his stool and moved over to a window that overlooked the myriad concrete and Tarvia runways that crisscrossed the field. The transverse bands of yellow-and-black pigment painted across the runways, to aid in night or fog landings, gleamed in the glare of the morning sun.

The field itself was completely surrounded by an electrified wire fence containing burglar alarms that rang automatic bells in the strategically placed guard posts and turned on huge floodlights.

Bill gazed across the field with unseeing eyes, until one of his yellow-and-black-and-red Snorters came plummeting out of nowhere and fishtailed in for a landing. Bill grinned as he saw it roll up to the apron and saw the stocky form of "Shorty" Hassfurther, his chief of staff, slide over the side of the forward cockpit to the concrete. Wearily, he turned back to the problem before him. He had just managed to throw everything else out of his mind when there was a loud, insistent pounding on the door of the laboratory. He frowned and didn't bother to answer.

But the knocking did not stop. It only became more persistent. He threw his pencil down, strode across the room with long, powerful strides and opened the door. His face was like a thundercloud.

"Listen!" he said, as he saw the grim face of Shorty Hassfurther. "I left orders——"

"And I canceled them," Shorty said. He stuck the newspapers he had in his hand at Bill. "Get an eyeful of that and see how you like it," he finished.

Bill spread the first paper out. The headlines that jumped at him drove the breath out of his body in a long-drawn whistle. He quickly looked at the headlines of the other two papers and then he stared at Shorty. His face was twisted into a grim mask of anguish.

"Marty Dewart and Jerry Winsor," he said, softly.

He laid the newspapers on a bench and drove his right fist into his left palm with a characteristic gesture. "This," he said, "is horrible. It's going to set the air lines back ten years. It——"

"Did you see what they said about Jerry Winsor?" Shorty asked.

"Who said?" Bill asked. He grabbed at the papers again.

"The bright newspaper hounds," Shorty answered. "They intimate that both he and young Parks, the co-pilot, were drunk."

"Drunk!" Bill roared. "Jerry Winsor never took a drink in his life." His eyes raced down the column. He shook with indignation as he read:

Ambulance doctors, policemen and firemen, who helped remove the mangled bodies of the victims from the wrecked plane all agree that there was a very distinct odor of liquor about the remains of the pilot, Jerry Winsor, and William Parks, the co-pilot.

"A dirty, filthy lie!" Bill snarled. "Jerry Winsor and Marty Dewart were two men who took their business seriously. They were two of the best transport pilots in the world. They both had a million miles behind 'em. I can't understand it, Shorty. I can't understand it!"

"That's what old Benjamin Shipman of Amalgamated says," Shorty said, dryly. "The papers are clamoring for the government to put Amalgamated out of business."

"It says," Bill went on, "that Marty was riding the radio beam and his co-pilot was checking in regularly by radio right up to the time the accident occurred. Yet it was fifty miles off its course. How the hell could that be?"

"It couldn't," said Shorty. "It isn't possible for such a thing to happen. There's something screwy some place, Bill."

"I'm not going to stand by and see two men like Marty Dewart and Jerry Winsor take the rap for some kiwi, after they are dead and can't

speak for themselves," Bill said. "Jerry Winsor taught me half the things I know about flying, Shorty. After he was born, they broke the cast. He was one guy in a million."

"I know it, Bill," Shorty said, softly. "Remember I knew Jerry a long time before you did. We were in the same squadron in France for nearly a year. He never let any one down in his life."

"The paper says reporters found broken bits of a whisky bottle in the pilot's compartment," Bill said.

"Jerry or Ralph Parks never put it there," Shorty said.

Bill looked up from the paper and gazed at Shorty with narrowed eyes. "What do you mean by that?" he asked him.

(Turn to page 63)

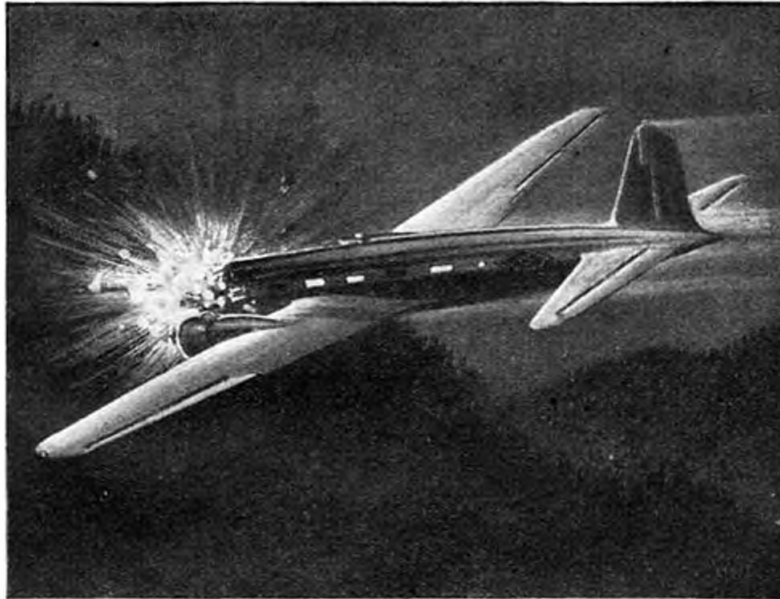

As the lights went out and the big ship folded up, the night was pierced by the horrible screams of the passengers.

# Seaplane Development

*ON JANUARY 26TH, 1911, GLENN H. CURTISS ROSE FROM SAN DIEGO BAY IN HIS "FLYING FISH," THE FIRST SUCCESSFUL SEAPLANE!*

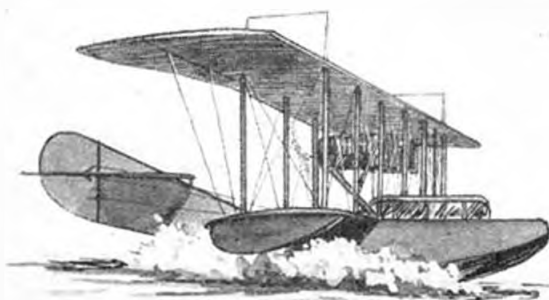

*CURTISS CONTINUED BUILDING AND IN 1914 APPEARED THE "AMERICA", A TRUE FLYING BOAT. IT HAD 2 90 H.P. CURTISS ENGINES. THIS WAS THE FIRST OF MANY SIMILAR SHIPS INCLUDING THE NC-4, THE FIRST AIRPLANE TO CROSS THE ATLANTIC FIVE YEARS LATER*

*IN 1919 SUCH TWIN PONTOON SEAPLANES AS THE ENGLISH FAIREY "CAMPANIA" APPEARED. A TWO SEATER OF OVER 75 M.P.H.*

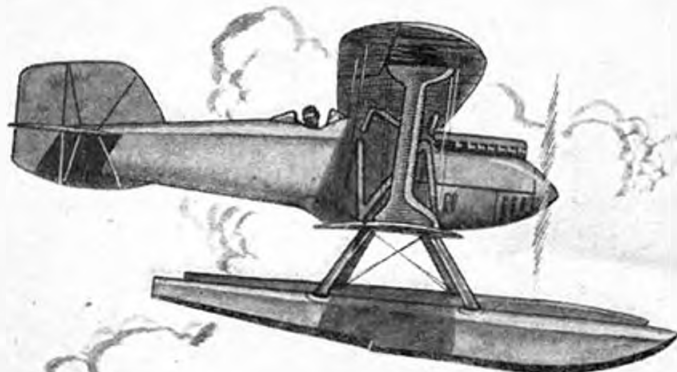
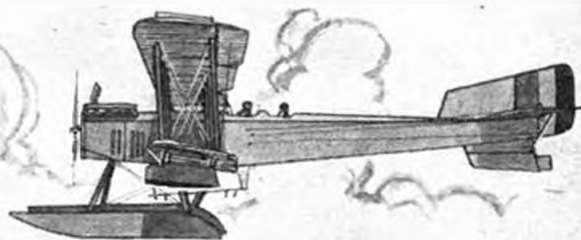

*BY 1924 THE SPEED OF THE SEAPLANE HAD JUMPED TO NEARLY 200 M.P.H. - WRIGHT'S NW2 SCHNEIDER CUP RACER WITH A 650 H.P. WRIGHT TIII ENGINE WAS TYPICAL OF '24*

*AND NOW THE MODERN DOUGLAS D.F. CARRYING 32 PASSENGERS, CREW AND FREIGHT AT 185 M.P.H. - THIS SEAPLANE WITH ITS 2 - 1,000 H.P. CYCLONE ENGINES HAS A RANGE OF 3,300 MILES*

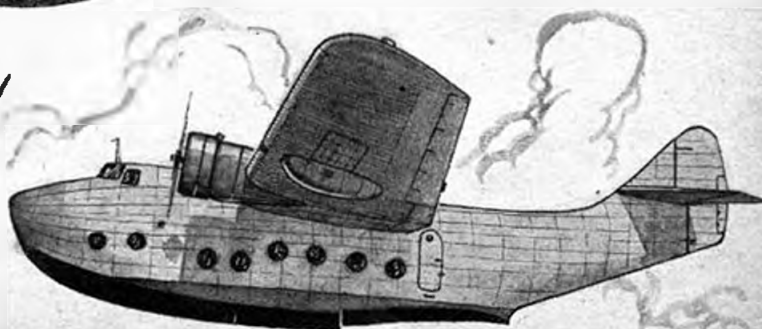



# GETTING INTO



Students busy in the modern radio laboratory of the Evening School of Aeronautics show that opportunities exist on the ground as well as in the air.

*This article continues the most vitally important series ever offered to young air-minded Americans. If you plan on the air for your career, follow it carefully. Save your copies.*

**T**WO gleaming new aircraft carriers, the U.S.S. *Yorktown* and the U.S.S. *Enterprise*, were launched and christened during 1936. As this is written they are nearing completion at Newport News and will soon be plying the ocean and mothering seventy-five or more airplanes apiece. New aviation squadrons, four for each ship, have been in process of formation for months at the Naval Air Station at Norfolk.

After the *Yorktown* and the *Enterprise* will come the *Wasp*, still another aircraft carrier, whose keel was laid at Quincy, Mass., on April 1, 1936. These three new carriers are in addition to the *Langley*, the *Saratoga*, the *Lexington*, and the *Ranger*, already in service. More than fifty other new vessels are under construction, not counting submarines, and fourteen others are being planned. Many of these ships will use airplanes, launching them into the air with catapults and hoisting them aboard after they land alongside.

All of this building is part of the five- to seven-year naval-expansion program, inaugurated in 1934, the goal of which is a "treaty-strength navy" by 1940 to '42. Before 1934 the navy was authorized to have only one thousand airplanes. The number of planes already authorized under the treaty-strength plan is one thousand, nine hundred and ten. Almost six hundred new planes are scheduled for delivery to the navy during 1937.

To fly these planes the navy must have several hundred more pilots, and the navy is securing them as fast

as it can. Training planes at Pensacola are dipping their pontoons every day into the blue-green waters of the Gulf. Silver wings are flashing through the Florida skies—and alighting just above the left breast pocket on young men's uniforms. Every month a new class of flying students is entering the navy school and an old class is graduating.

The chances are that this rapid training of pilots will continue for three or four years more. After that it may slow down. And it may not.

There are several ways to get to Pensacola as a flying student. The most important are:

1. As an aviation cadet of the naval reserve.
2. As a regular officer of the navy.
3. As an enlisted man of the navy.

A small number of students are aviation cadets of the marine corps reserve and a few are officers or enlisted men of the coast guard.

## TRAINING AS A CADET

About seventy naval reserve aviation cadets are being sent to Pensacola each month. The waiting list of qualified applicants has been a long one ever since the plan was inaugurated in July, 1935. But the air corps, left with unfilled flying cadet vacancies, has made its flying school offer more attractive—as related last month in AIR TRAILS—and it is probable that from now on applications will be more evenly divided between the two.

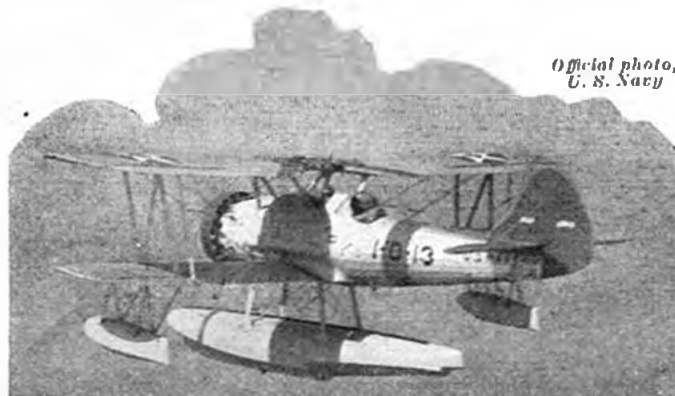

Official photo,  
U. S. Navy

Should you win your wings as an observation pilot, you would experience the thrill of catapulted flight.

# AVIATION

## PART TWO

by CLYDE  
PANGBORN  
and LIEUTENANT  
W.M. WOOD



Planes of the Scouting Squadron form steps heavenward as you would see them from the cockpit of a Vaught SBU-1.

If you are an unmarried male citizen of the United States, between the ages of twenty and twenty-eight, of good character and with practically perfect eyes and no physical defects great enough to cause you to flunk the rigid examination, and if, in addition, you have the requisite educational preparation, you may apply with good hope of success for training as a naval reserve cadet.

To qualify educationally you must be a graduate of a recognized college or university (and if you have studied aeronautical engineering you'll have a better than ordinary chance); or, be able to show credit for one half the work required for a degree and have completed thorough courses in arithmetic, college algebra, plane and solid geometry, plane trigonometry, and elementary physics; or, have secured equivalent education by other means and have experience, training or aptitude that makes you particularly desirable for the service in the opinion of the examining officers.

Application blanks and instructions may be secured by writing the Bureau of Navigation, Navy Department, Washington, D. C. Applications are submitted only to the commandants of the naval districts in which the applicants live, who direct the examinations and submit nominations, of those qualified, to Washington. If you are a successful applicant you are required to agree to remain on active duty for a total of four years, if the navy department

authorizes it, and you are enlisted to begin as a seaman, second class, in the volunteer naval reserve.

First you are sent to a naval reserve aviation base for a month of "elimination flight training." If you are eliminated you are sent home. If you are found to have sufficient flying aptitude you are appointed an aviation cadet of the naval reserve and sent to the naval air station at Pensacola.

At Pensacola you get thorough flight training in both sea and land planes, including aerobatics, night flying, instrument flying, cross-country flying, and formation flying. The advanced military work includes scouting, observation patrol, and fighting-squadron operations, which embrace aerial machine gunnery, bombing, tor-

How the home port would look when on flight duty with the aircraft carrier, "Lexington."

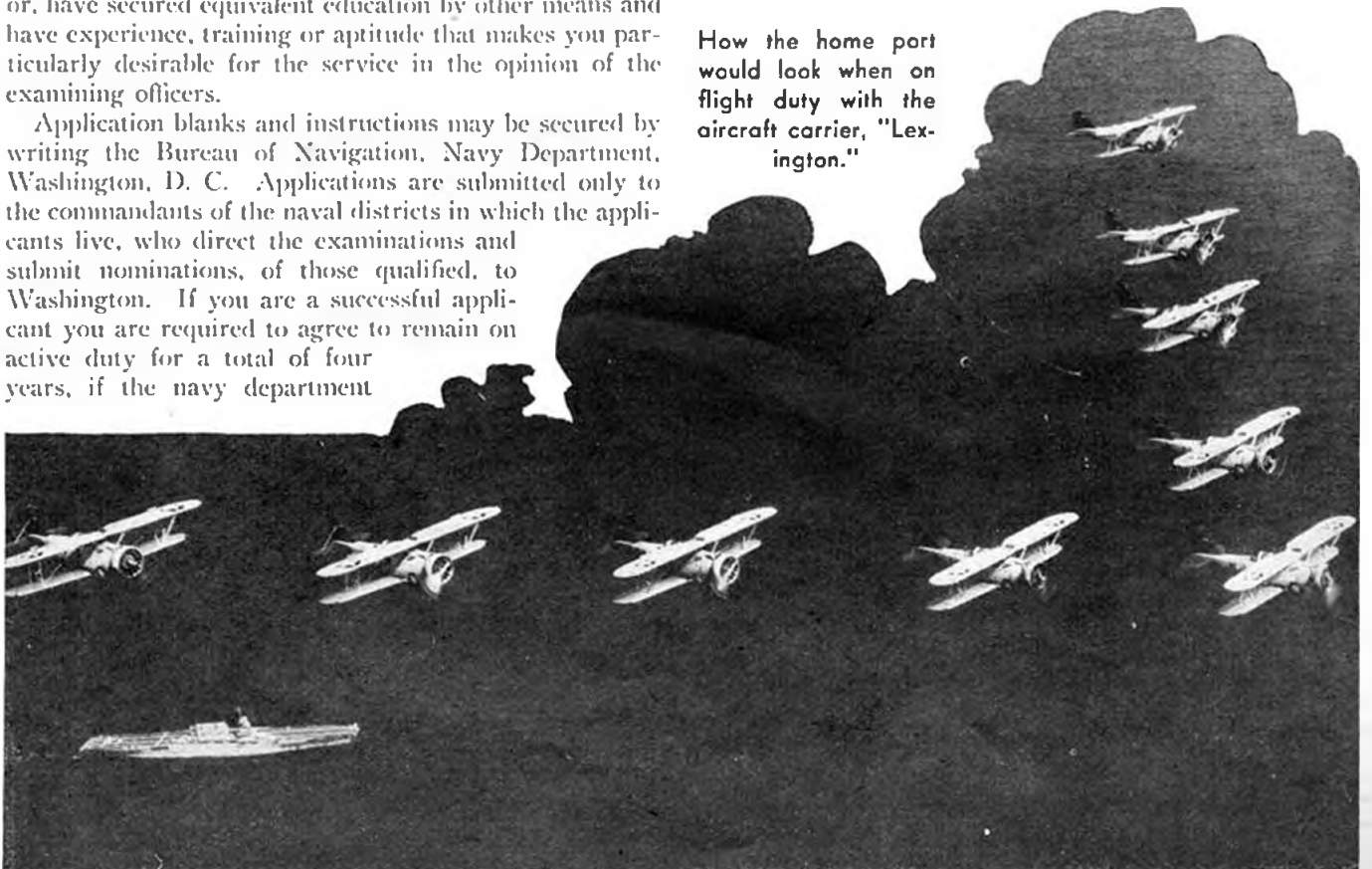

pedo dropping, catapult take-offs, single combat, and other military procedure.

In the ground school you study the regular aviation subjects, such as navigation, aerodynamics, meteorology, airplane and engine maintenance, and radio code. In addition, there are special naval courses such as nautical navigation, gunnery, practical seamanship, and so on. In addition, there is military drill and calisthenics.

Training is on a double schedule at Pensacola these days. While part of the students fly in the morning, the rest are in ground school. In the afternoon the groups exchange places. The group which does morning flying one week does afternoon flying the next, in order to split the bumpy afternoon air evenly. Cadets are up by six a. m. and ready for flying or classroom by seven thirty, five days a week.

On graduation at the end of one year from the course at Pensacola, naval reserve cadets are rated "naval aviator," given their wings, and ordered to active duty with aircraft squadrons of the United States fleet, provided such duty is authorized. As long as pilots are needed in the expansion program it is expected that graduate cadets will be ordered to active duty. How long this will continue, or how many cadets in the future will be kept on for all of the three remaining years to which they have agreed, is a matter of conjecture. If you want to do any guessing about it, here is a bit of information.

Around forty to fifty out of each class of about seventy



A twin-engine, small transport of the type used for advanced flight training, at the Parks Air College.

sent to Pensacola have been graduating each month. If the navy keeps on sending as many as forty cadets a month to the squadrons it will have sent about one thousand, four hundred and forty by the time the first class trained is scheduled for return to civil life in the summer of 1939. In addition, there are the regular officers and the regular enlisted men being trained every year. Information as to how many regular personnel are being trained is restricted by the

navy department. But our own private guess is that from seven hundred and fifty to eight hundred regulars, officers, and men together, are being sent to Pensacola during the present fiscal year. Half of these should get through. If the navy keeps on for very long, at the present rate, it is going to have lots of pilots. But then the naval limitation treaties expired on December 31, 1936, and have not been renewed.

Foreign powers have begun construction of eleven dreadnaughts, in addition to the swarms of smaller ships. And on the day before this was written President Roosevelt ordered construction of two great battleships for the United States. That shows you how the wind is blowing. Bad news for the world, but people who want to fly can profit by it—and hope that their flying skill may help scare the nations into not fighting after all.

Have you been wondering how much money you would get as a naval reserve cadet? Well, for the first month, as a seaman second class, you would get fifty-eight dollars cash. At Pensacola, for a year in training, you would get seventy-five dollars a month. Afterward, as a graduate aviator with a squadron, you would get

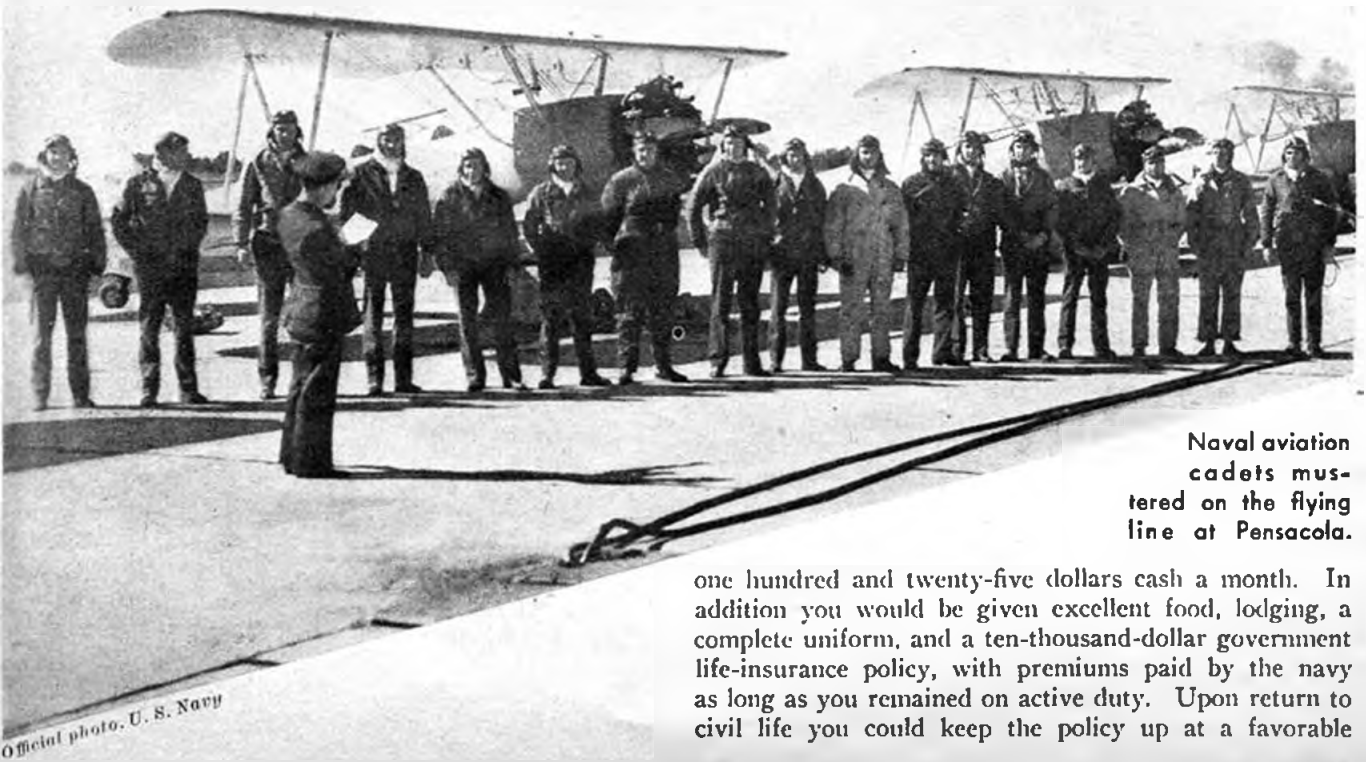

Naval aviation cadets mustered on the flying line at Pensacola.

one hundred and twenty-five dollars cash a month. In addition you would be given excellent food, lodging, a complete uniform, and a ten-thousand-dollar government life-insurance policy, with premiums paid by the navy as long as you remained on active duty. Upon return to civil life you could keep the policy up at a favorable

This Grumman F3F-1 typifies the planes you would fly as an accomplished fighting navy pilot. The particular plane shown is one of many now assigned to the carrier "Ranger."

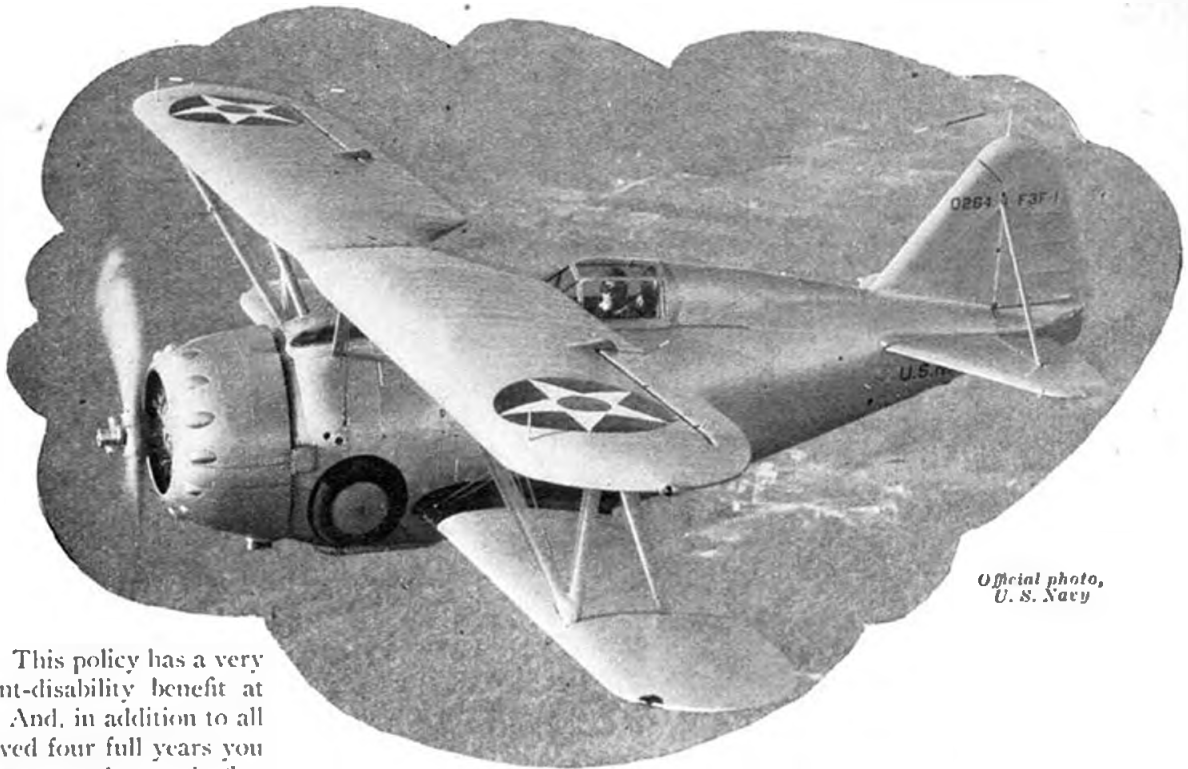

Official photo,  
U. S. Navy

premium rate. This policy has a very good permanent-disability benefit at no extra cost. And, in addition to all this, if you served four full years you would be given one thousand, five hundred dollars in cash to take home with you when you were released from active duty. At that time you would also be commissioned an ensign in the naval reserve.

This reserve commission would give you the privilege of doing a certain amount of flying in navy ships at the naval reserve bases, and you would be eligible for short, active duty periods from time to time. However, under present regulations there is little chance for a young man taking the Pensacola course as an aviation cadet to get himself a permanent flying job in the navy, marine corps, or coast guard. Nine lucky cadets got marine corps commissions last August, but that was most extraordinary.

#### GETTING IN AS A REGULAR

If you think you would like to be a permanently commissioned aviation flight officer of the regular navy, there is only one way.

That is the long way through the United States Naval Academy at Annapolis, Md., where all prospective regular navy officers are given their training. A young officer recently graduated



from Annapolis may very probably go to Pensacola for flight training if he wants to, provided he can pass the flight physical examination. A lot of Annapolis graduates cannot pass it. And the usual percentage of those who do pass it and begin flight training are "washed out" and put back on non-flying duty. Thus, if a man comes through as a good pilot, he has an excellent chance for flight duty if he graduates from Annapolis.

It isn't so easy to get through Annapolis—but getting in comes first. To begin with, you must be between the ages of sixteen and twenty on April 1st of the year you

enter, a citizen of the United States, unmarried, at least five feet five inches tall, free from physical defects and in good health, and possessed of a complete high school or equivalent education.

Students at Annapolis are midshipmen—not cadets—in the regular navy. There are about two thousand in the school. Close to six hundred or seven hundred new ones enter each year. Most of them are appointed by senators and representatives in Congress. You should communicate directly with your senator or congressman about such an appointment. Each year one hundred enlisted men from the regular navy and twenty-five from the naval and marine corps reserve are chosen by competitive examination. In addition, the President is authorized to keep at Annapolis forty midshipmen, appointed by him, from among the sons of men who were killed in the World War or died of injuries before July 2, 1921. The President also appoints four from the District of Columbia and fifteen others "at large" each year. Fuller information may be had by writing the Bureau of Navigation, Navy Department, Washington, D. C. There are a number of schools which specialize in preparing boys to enter Annapolis. Two located nearby are the Severn School, Severna Park, Md., and the Cochran-Bryan Prep School, Annapolis, Md.

While attending Annapolis, midshipmen are paid seven hundred and eighty dollars a year. Food and room are furnished, but they buy their own uniforms. The course is for four years. Upon graduation they are commissioned ensigns in the regular navy. Naval officers get base pay ranging from one thousand, five hundred dollars a year for newly commissioned ensigns up to eight thousand dollars for admirals, plus various allowances. The allowance for flying duty is fifty per cent of base pay. The lowest salary paid a flying officer is close to two hundred and fifty dollars a month.

#### FLYING FOR NON-COLLEGE MEN

Now comes the information we promised you last month on how a number of young men (Turn to page 81)

# The Flaming Finish

*Then, suddenly,  
things weren't perfect  
any longer—*

A rapid-action story of the air

by A. R. ELROD

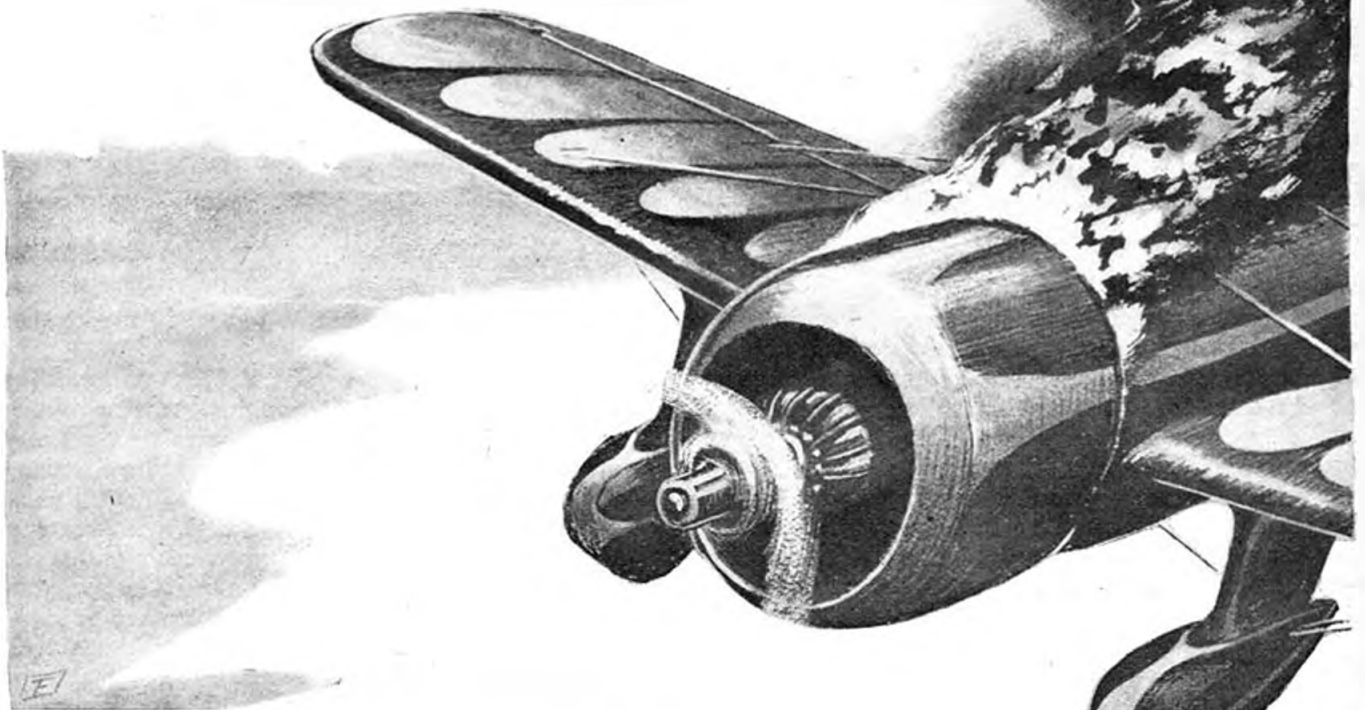

JOHNNY WALGREN stood on the third rung of his stepladder and with a feeler gauge and screw driver did things to his racing plane's engine. The tools made clinking, musical sounds in contact with the steel; and Johnny made allegedly musical sounds, humming. It didn't matter at all about the tune. Nobody heard him. He was alone in the hangar, and nobody could get in because the doors were closed—and locked; he'd seen to it himself that they were locked securely.

So he worked deftly, and he felt exactly right about everything. Everything was as perfect as it possibly could be, and he was happy. For last night Gwen Gibbs had come back, and to-morrow he was going to win the Benson Trophy race—if this Wasp did its stuff the way it should.

And then, suddenly, things weren't perfect any longer. A figure lurched from the lean-to office of the hangar and weaved across the concrete floor. Poised and alert, there on the ladder. Johnny looked down at big Dan Gibbs, Gwen's father; and even from this distance he could tell that Dan was drunk again.

"You li'l fox!" Dan Gibbs boomed, advancing on unsteady legs. "You li'l fox, I knew you'd be here, an'

I made 'em let me in!" He came up to the ladder, a florid-faced man in a shaggy brown wind-breaker jacket and a crumpled hat. His eyes were slightly glazed. "You take care of this li'l puddle-jumper, kid, an' to-morrow we'll both be rollin' in the dough!"

Standing there with his hands full of tools, Johnny kept the anger and disappointment from his voice. He said, "I thought you were on the wagon, Dan——"

"G'wan!" roared Dan. "Listen, kid, I sold the circus, an' I just bet sixty thousand iron men on you to win the Benson go."

Johnny Walgren whistled through his teeth. As he climbed down from the ladder, he felt cold. He regarded Dan with incredulity.

"You—what?"

"I sold our flying circus," Dan repeated.

Oddly, when Dan was drinking, his tongue never thickened very much, and his speech was always clear. He did idiotic things when he was drunk, and sometimes never knew he'd done them, later on. Once he had traded a new tri-motored airplane for a run-down

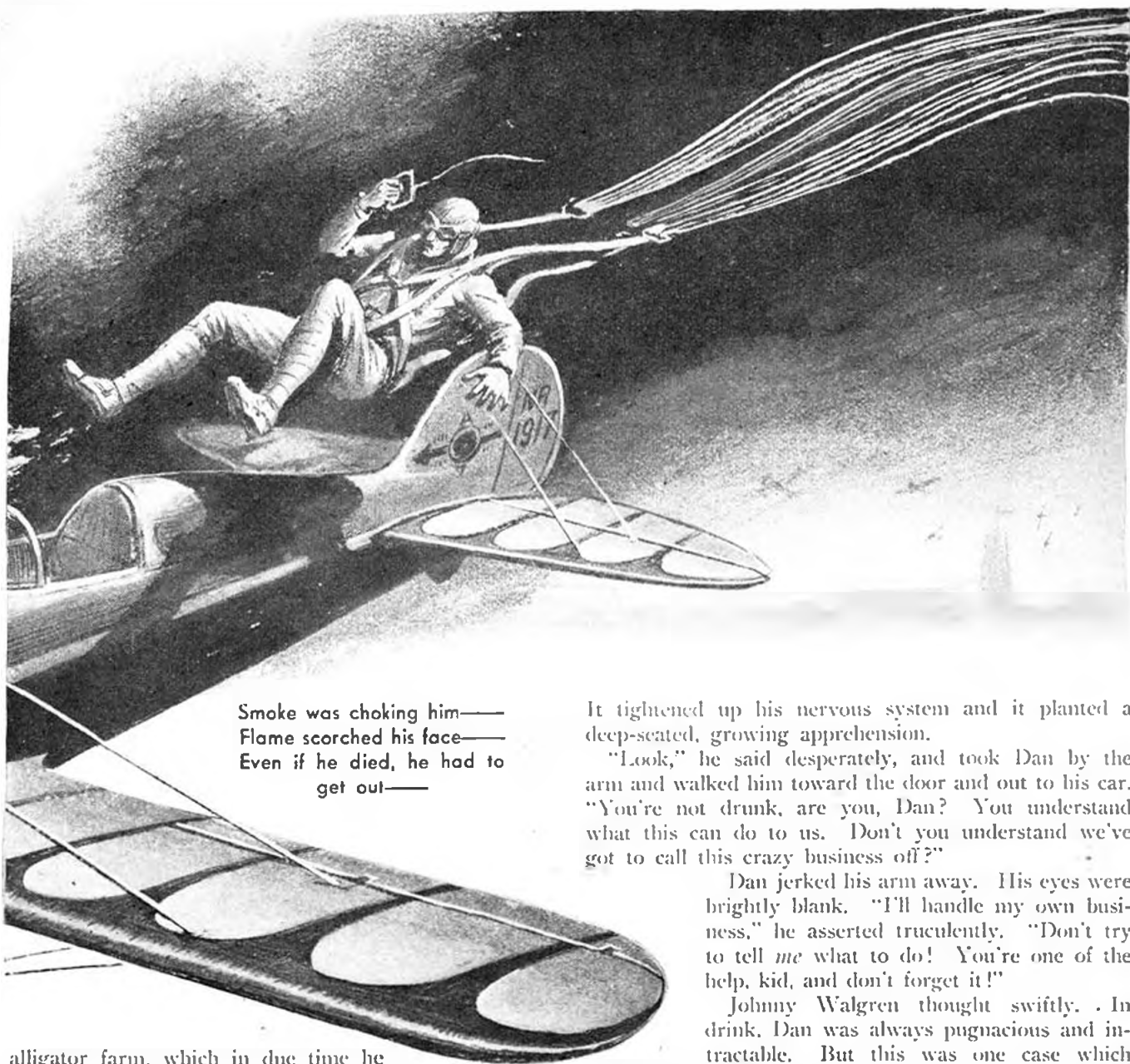

Smoke was choking him—  
Flame scorched his face—  
Even if he died, he had to  
get out—

alligator farm, which in due time he let the sovereign State of Florida confiscate for taxes.

"Sold the circus!" Johnny echoed in a hollow tone.

"Well," said Dan, "I didn't just exactly sell it, kid. An English gen'leman tried to give me sixty thousand dollars for it, but I wouldn't sell at first. So we made a sporting proposition. I bet the circus against his sixty thousand dollars, so I just the same as sold it out. I guess. Only, I was mighty slick! To-morrow, I'll have the sixty thousand and we'll have the circus, too!" He slapped his thigh and laughed uproariously.

Johnny pursed his lips and frowned. "Listen, Dan," he said. "Are you so drunk you can't remember? Who was the Englishman?"

"You wouldn't know him," Dan said. "All you've got to do is win the Benson race to-morrow, and we're rolling in the dough!"

Johnny wondered how it was possible to feel so confident and grand one moment, and so downright scared the next. Just a while ago he had been sure he'd win the Benson race, but now he wasn't sure at all. The knowledge that everything in the world he and Dan had was in the balance of that race did something to him.

It tightened up his nervous system and it planted a deep-seated, growing apprehension.

"Look," he said desperately, and took Dan by the arm and walked him toward the door and out to his car. "You're not drunk, are you, Dan? You understand what this can do to us. Don't you understand we've got to call this crazy business off?"

Dan jerked his arm away. His eyes were brightly blank. "I'll handle my own business," he asserted truculently. "Don't try to tell *me* what to do! You're one of the help, kid, and don't forget it!"

Johnny Walgren thought swiftly. In drink, Dan was always pugnacious and intractable. But this was one case which couldn't be allowed to run its normal course, Johnny realized. Suppose that he *didn't* win that race to-morrow. Everything would be lost: a dozen splendid planes, ten years of work, all hope for the future—everything. He had to stop it. And he was going to stop it.

"Who was this Englishman?" he asked again, persuasively. "Don't you want me to go along and talk to him and be a witness to the terms?"

"Terms're all right," Dan grumbled. "We got plenty witnesses. I was slick enough for that, kid. Now you finish checkin' that engine—an' to-morrow you better win that race!"

"Dan," Johnny pleaded solemnly. "stop and think a minute, please! Are you so drunk you don't know what this—"

"Stow it, kid!" Dan snapped.

"I won't stow it," Johnny answered stubbornly, his voice a little shrill with rising anger. "You haven't got a right to do a thing like this, and I won't let you!" He took hold of Dan's arm again, and urged him toward the car.

Dan brushed his hand away. "Keep your greasy fingers off me," he growled.

A kind of desperation seized Johnny Walgren suddenly. He tightened his grip, propelling Dan with force.

And Dan Gibbs swung at him with a vicious, massive fist.

Johnny dodged. It happened so unexpectedly that he had no time to check himself, to think. He wouldn't have struck Dan for a thousand dollars; but when Dan jabbed, he countered reflexively with a left hook that connected with a thudding impact. Dan crumpled in a heap, and he didn't get up. Stupefied by alcohol and stunned by shock, he passed out, cold.

For a moment, it all seemed utterly unreal. Realization and reaction left Johnny Walgren weak and sick. As a crowd of curious bystanders gathered, he lifted Dan's great bulk into the back seat of his car and got in and drove to town. A doctor wasn't necessary, but he got a doctor. They took Dan to Johnny's room at the hotel and got him into bed. The doctor was to stay there for a while. There was no use in Johnny's staying; it would be no use to question Dan Gibbs further, now.

Johnny went back and finished checking the engine of his plane. His mind kept turning to Gwen, and he was miserable, wondering how he could bring himself to tell her what had happened. There was no one in the world more lovable than Dan Gibbs—when he was sober. Johnny decided he wasn't going to tell Gwen, unless he lost the race.

The race loomed now not as the joyful competition it had been, but as something which dismayed him with its consequences. He could beat most of the field with ease, of course, but he might not beat Duke Harde. To beat Duke—How could he be sure of that, when Duke had beaten him in four races out of seven in the past two years? But he had to beat Duke.

It was almost dusk when he finished the Wasp—the swift, opalescent dusk of the tropics. Johnny locked the hangar carefully, went outside and stared moodily across the flying field. Overhead, stars incredibly brilliant stabbed through the purple dome of night. The Miami sky line threw up a band of delicate blue amber on the clouds. The peace and serenity of evening brought to Johnny a sudden weariness with the constant, stark uncertainty of barnstorming.

He was tired. He decided he would give this race to-morrow everything he had, and then put in two months loafing. He remembered, suddenly, that he couldn't loaf now. If he were to do anything about that bet, he must get back to the hotel and question Dan.

But when he reached the hotel, he found Dan gone. There was a sheet of paper stuck against the door with Dan's penknife. It said:

Get some sleep to-night so you can do your stuff to-morrow. Don't hand me any square lock washers, kid!

P. S. I paid the doctor.

Johnny tore up the note in anger. One thing, Dan was getting sober. If he got sober enough, he might call that fool bet off—if he remembered having made it. He must have remembered it, to say that in the note. Johnny felt worried and sore as a fresh blister. He was in no frame of mind to see Gwen, but he would have broken his leg before he would have broken a date with her.

As best he could, he composed his mind, while he dressed and went to her hotel. To-morrow, somehow, he'd win that race, and everything would be all right. Or maybe, before the race, he could bring Dan to his senses, if it wasn't too late. But to-night, he'd try to show Gwen how glad he was to have her back.

She met him in the lobby. She wore an evening dress of sheer blue stuff that deepened the color of her eyes. Johnny forgot about Dan Gibbs, almost.

They were finishing dinner at the Babylon when the waiter came unobtrusively with a note, and whispered, "The man at the table under the balcony sent this, sir." Johnny took the note, and furtively scrutinized the man. He was dark, with thin, tense lips.

The note was in a scrawling, penciled hand. It said:

If you want to make ten thousand dollars, come and see me.

Johnny sat there frowning at it, puzzled by a vague sense of warning. It was absurd, that feeling, but it was very real.

Gwen said, "He's mysterious-looking! Isn't it nice I'm never overcome with curiosity?"

Johnny grinned. "Some day those prying little ears will get you in a jam. I've got to find out what this is." He thought he knew already, but he slid his chair back and got up.

"The next dance is going to be a waltz!" Gwen protested with her best hurt look. But Johnny was already swinging his rangy frame across the polished floor.

He folded down into the waiting chair, under the balcony, and looked into a pair of inscrutably cold eyes in a hard, tanned, impassive face. He said huskily, "O. K., let's have it. Fast."

"Hello, Walgren," the man said; "my name is Gerro. There's ten grand in it for you if you drop the Benson Trophy race to-morrow. Have I said it fast enough?"

Johnny thought, "I guess I did know what it was about." He started to get up. "Not interested," he said curtly.

Gerro's voice, utterly cold, pinned him back against his chair. "You do not win the race to-morrow. I am telling you. If you win to-morrow, you won't live five minutes. You should be interested in that."

A kind of tingling numbness spread like a flush across Johnny's rugged, wind-burned face. Anger brightened his eyes, but an underlying caution checked him.

"What makes you think you'll get away with this?" he challenged.

Gerro's strong brown fingers manipulated a silver cigarette case casually. "There are ways of doing things," he said.

"Not this," Johnny snapped. "Why, you——" He reached across to grab Gerro by the collar, but the other was too quick.

"Do not be a fool!" Gerro murmured, unperturbed. His right hand was underneath his coat lapel; his left was pushing a slip of blue paper across the tablecloth. He added with a spurious benignity, "You can cash this at Tony's—after the race. We are generous. We could merely kill you, you know. But we are not joking!"

Johnny stared at the draft. It was for ten thousand dollars, payable to him. He said, "Who sent you to try to fix this up with me?"

(Turn to page 84)

# THE FLIER'S DICTIONARY

The nineteenth lesson in the technical terminology of the air. Save your files!

## AVIATION MARKINGS

- 1 Route arrow, with mileage to town marked.
- 2 License number on bottom of lower left wing and top of upper right wing. Letter "S" before number represents "State," meaning ship is the property of State or government.
- 3 The letter "R" before the number means the plane is limited to "restricted" uses.
- 4 The identification mark on lighter-than-air craft is placed one quarter of the total length back from the nose.
- 5 Transport planes may have their line identification mark on upper left wing and lower right wing.
- 6 The letter "N" before the "C" means that the plane is a United States plane. This "N" must be on all planes crossing national boundaries, and may be used on all planes except gliders at the selection of the owner.
- 7 An identification number or mark must be on all free balloons at the maximum diameter. This must be on two sides of the aircraft.
- 8 The letter "C" before the number means that the ship has a commercial rating.
- 9 Town identification mark on roof.
- 10 Meridian marker showing true north. Arrow and letter "N."
- 11 Airport marker pointing to nearest airport and giving mileage and type.
- 12 The letter "G" is placed before the number on all gliders and soaring ships.
- 13 Route arrow, without mileage on roof.
- 14 Air markings on highway showing junction of routes.
- 15 The letter "X" before a number means that the plane is to be used for experimental purposes only.
- 16 Private planes must have an identification number or mark, but may not bear the "N" of licensed planes.
- 17 The license number and letter must be painted upon the vertical tail surface as well as on the wing.

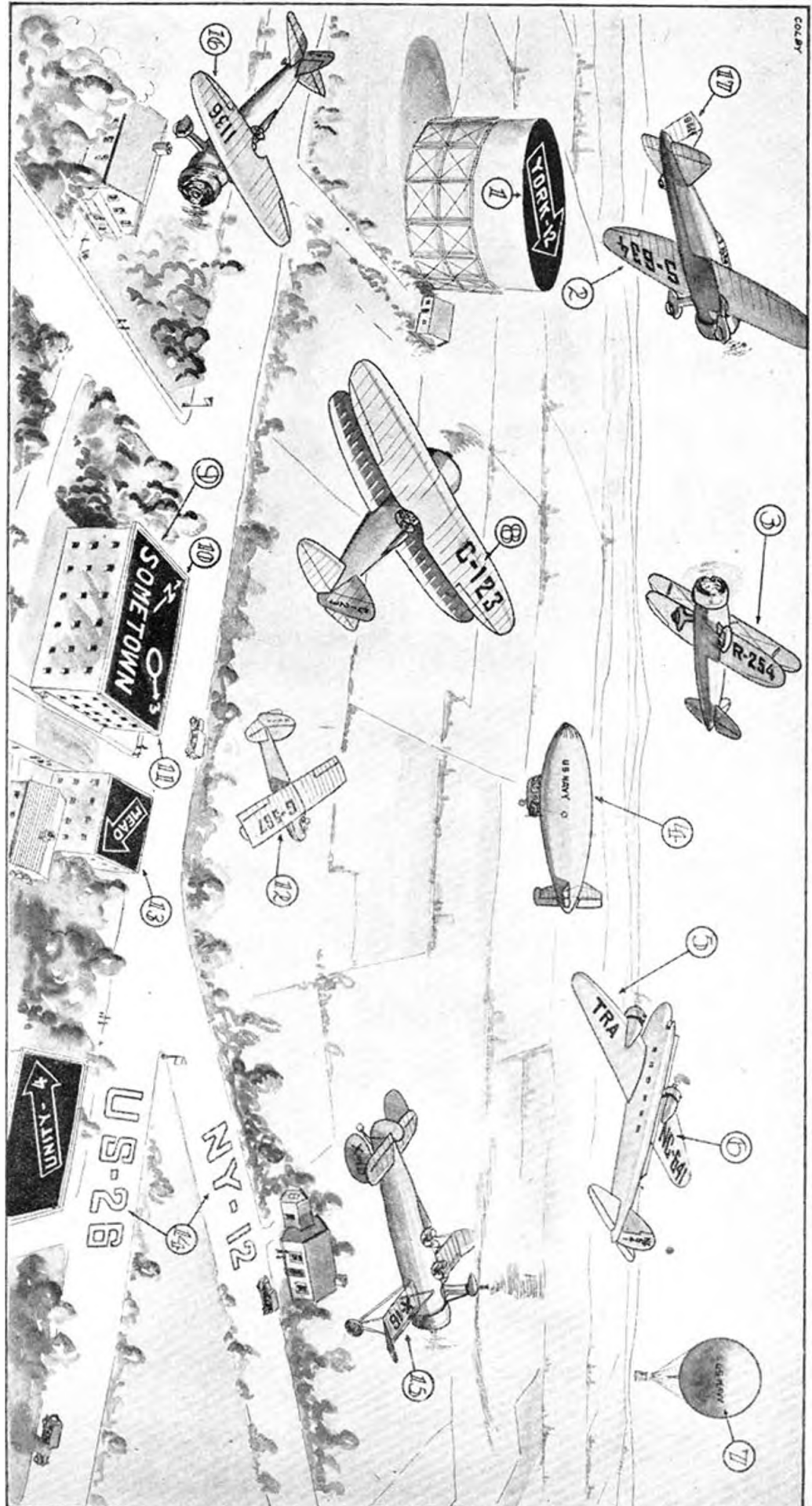



AT five thousand feet Frank Bireley raised his hands above his head and yelled, "Take it!"

What a thrill! My third time up in a plane and I was to fly it on a full hour's trip from Los Angeles. The instructions sounded simple: keep her nose at a level flight position on the horizon, and at the same time keep the wings parallel to the earth's surface.

I wandered all over the Southern California sky in the next fifteen minutes. My eyes jumped to the altimeter long enough to learn that I was down to one thousand feet—and had to climb. The next time I looked, we were up to eight thousand! My companion did very little correcting and only when absolutely necessary. But we wound up at Lake Norco as planned!

After less than four hours of dual instruction it seemed to me that I was prepared to solo—but safety factor is a prime requisite in aviation. There followed practice glides, climbs, take-offs, landings at strange fields. Bireley overlooked nothing in the twelve hours of flying that followed. During this period I was checked by a number of different pilots. Eddie Anderson, a graduate of Pensacola, gave me much of this advance training, covering aerobatics, cross-country, and emergency maneuvers; and Eddie was my final check pilot.

One day when we were "beating a path" around the Metropolitan Airport à Van Nuys, Eddie hopped out of the cockpit on one of the landings and said, casually, "Take it around."

Without a second's hesitation I "poured the coal on" (opened the throttle) and took off. It all seemed so easy and natural, the way she rolled ahead and lifted her nose

# TAKE IT AROUND

by Frank Kurtz

into the wind; then, suddenly, there came that all-alone feeling. For the first time I was not looking at the back of a helmeted head while I flew. I was on my own. Eddie was gone. It was really my solo flight!

The old OX5 Waco circled the field steadily while my confidence gained. We were headed back for a landing—the real test of my training. Cutting the throttle, I dropped the nose below the horizon, assuming a normal glide for the approach. A thousand warnings pounded through my head: "Don't lose flying speed!" "Clear all wires!" "Watch the wind!" "Don't ground-loop!" They were confused, mingled, maddening, though they seemed to come clearly through my ear phones in my instructor's familiar, calm tones.

I was safely over the wires. I was breaking the glide. A few seconds and the wheels were rolling along the ground. I was down! I had soloed and was in line for congratulations!

Eddie ran alongside. "Well, you did get it down in one piece," he greeted, "but what the heck were

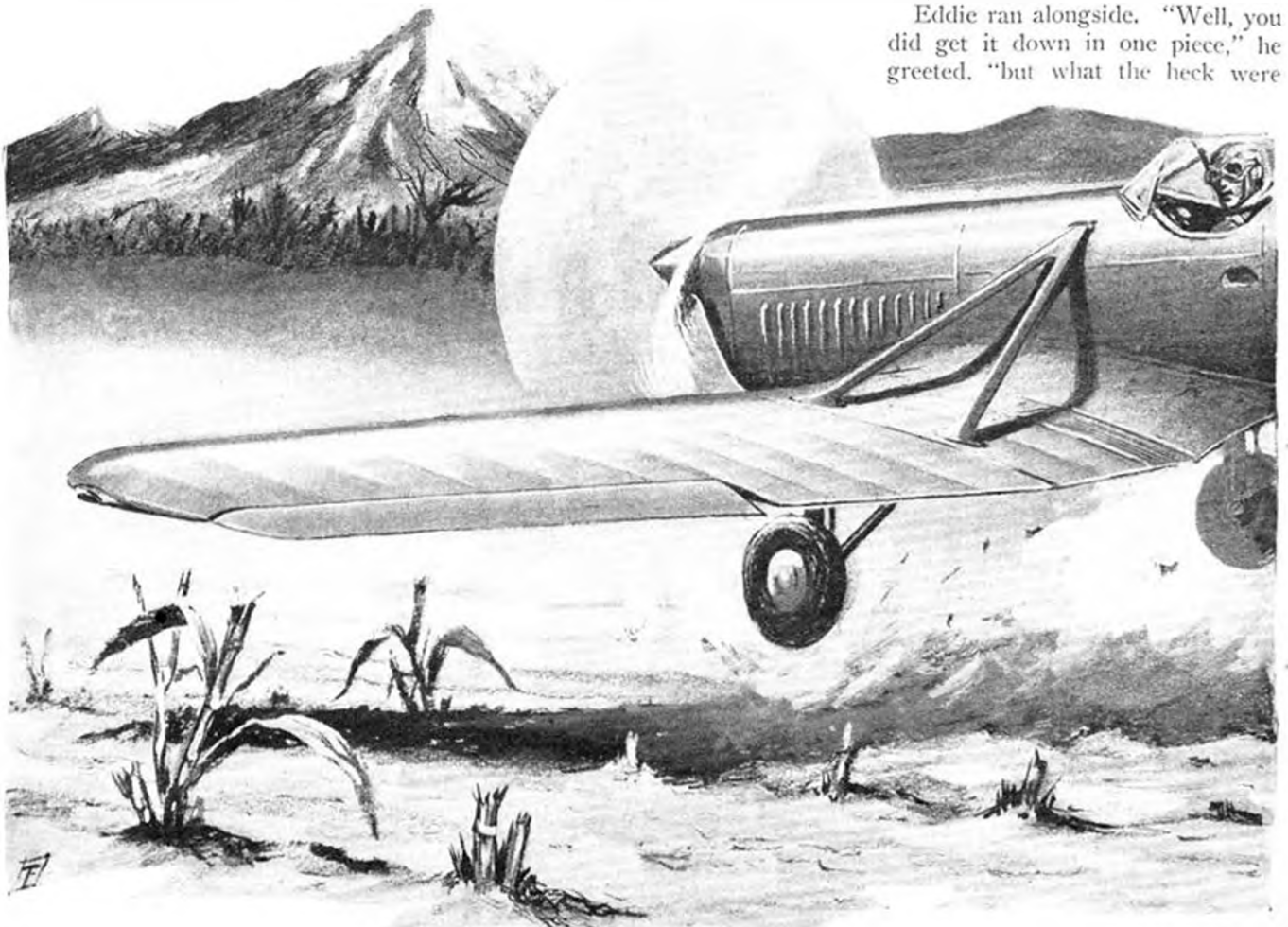

*The true story of a boy who wanted to fly—and did. Frank Kurtz earned his private pilot's license at sixteen; set a world's junior speed record for land planes at seventeen; and at twenty-one had more than one thousand flying hours in his log book!*

you doing on that take-off? Your turns gave me a 'ship-the-body-East' feeling."

This continued for five minutes—and I had expected congratulations!

In order to become a pilot, one must build up many hours of "solo" time, and then take prescribed flight and written tests from the department of commerce inspector. This means work and study. I enrolled in night ground-school courses. The following few months were spent practicing figure eights, spirals, landings—those requirements prescribed in the department-of-commerce test—and in going to ground school at night. The ten hours required for my private license were soon completed and I was set for the test.

I was brimful of confidence. Eddie had tutored me and told me, in his convincing, assuring manner, that I had nothing to worry about so long as I did as I had been doing in practice flights. We were watching another pilot take his Limited

Commercial Test (the second-ranking license, transport being first) and the inspector had instructed the pilot to go to five thousand feet, make two spins to the left, climb back to five thousand, then make two spins to the right and assume normal flight, after which he was to land.

He followed the instructions fine until he was supposed to land. Instead, he went back up to five thousand, put the Fleet into another left spin and never came out. Due to propeller torque, a left spin is more difficult to recover from than is a right one. He apparently became confused and lost his head, for after spinning two or three thousand feet, he could have used his parachute, but he didn't. When he hit the ground, the impact was such that he went right through the instrument board and into the front cockpit. One look and I didn't want any lunch.

It was my turn to go up for the test. I think I must have bounced all of five times on my first landing. Eddie told me I'd better get rid of the "buck fever" if I wanted a license, and that the next two landings had to be "on the button." Such maneuvers as spirals, landing to a line (theoretically, a forced landing with a dead motor), figure eights, one-hundred-and-eighty-degree turns and land to a line without use of the throttle, seven-hundred-and-twenty-degree turns and land (two complete circles and a glide into landing without throttle), and spins were done in order.

Having previously passed my written test, which included a working knowledge of the department of commerce air-traffic rules and regulations (this part of the examination is comparable to a test for an automobile driver's license, in that it requires that one must know the rules of the airways as well as of the roadways).

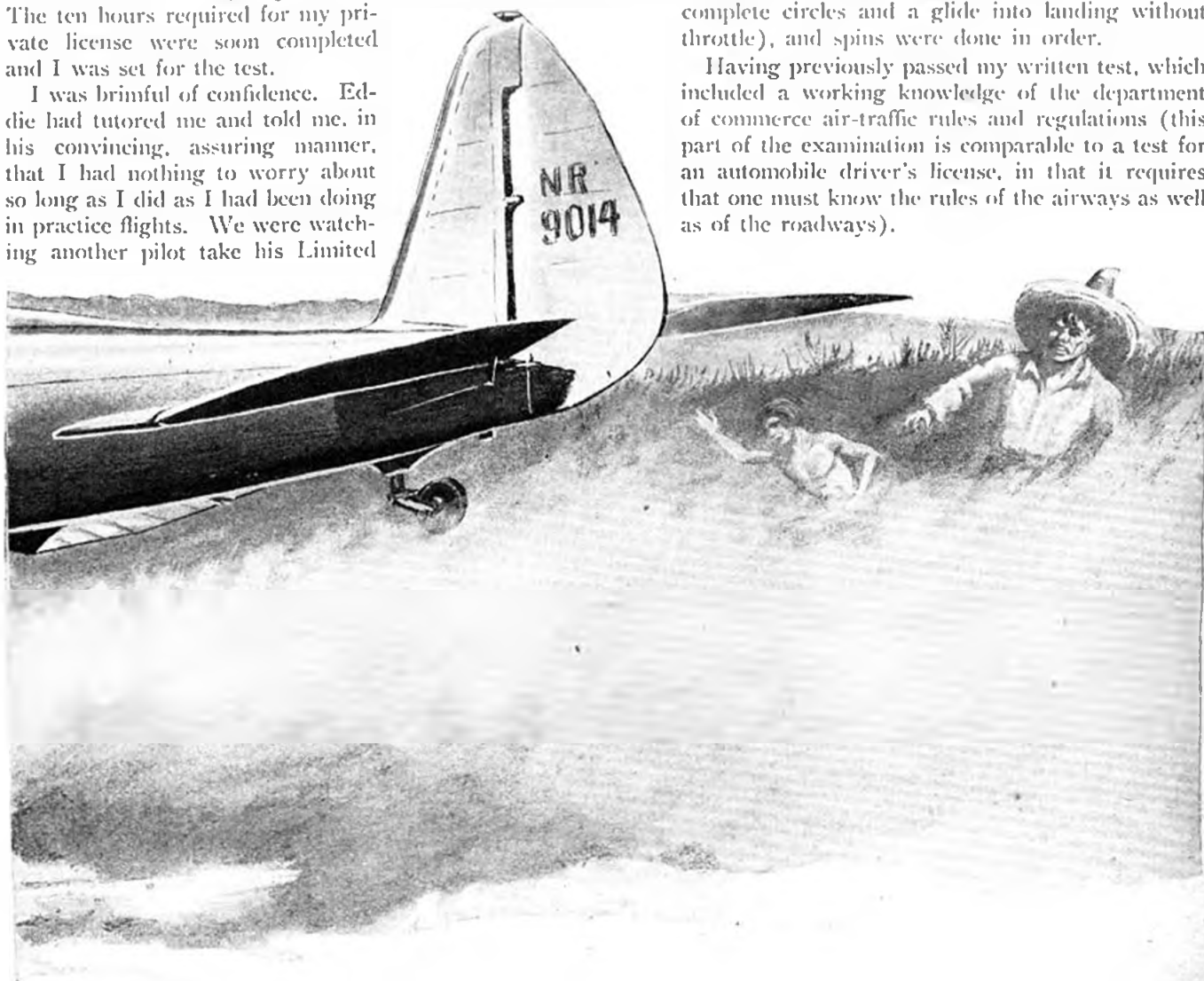

In Africa it's bright beads that attract the native eye  
—in Mexico it's flashlights.

Upon completion of my flight test, the inspector wrote out my ticket. That day will always stand out as one of the biggest of my life.

I had been flying nine months and felt like a veteran. Much was happening in aviation, and I got to thinking I could do my bit. The idea of a world's land-speed record struck me. I confided my ambition to Bireley.

"Why not?" agreed Bireley. This was the answer I had been waiting for.

It was May, and I had over one hundred and ten hours of solo. There were obstacles to hurdle. First, there was no official closed course west of the Mississippi over

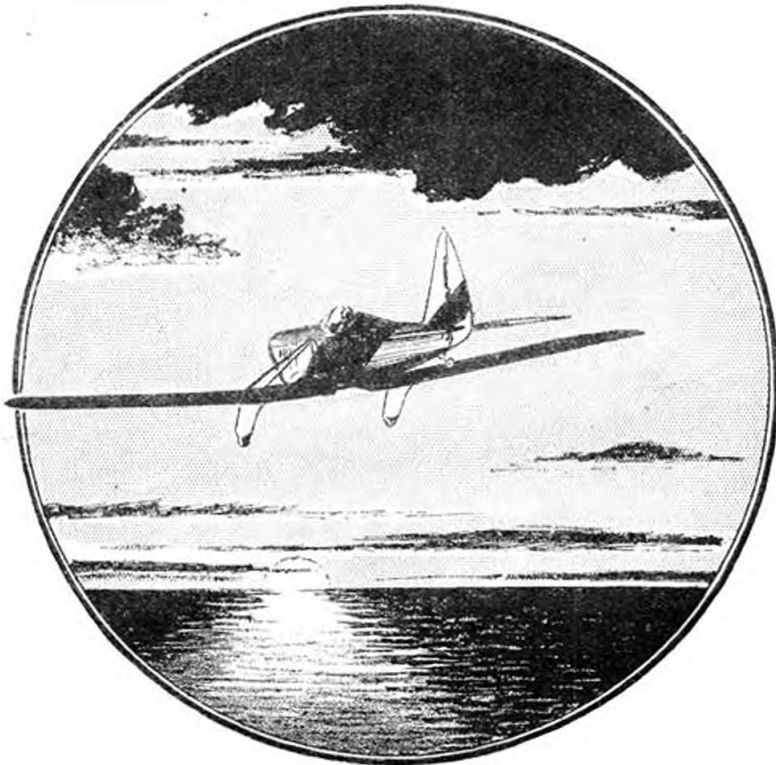

Suddenly I discovered my compass had taken time out—  
and over the Gulf of all places! It was getting dark—  
The situation was becoming tense—

which these record events must be timed in order to receive official sanction and recognition. With the cooperation of the National Aeronautical Association, the city of Seal Beach and the Union Oil Co., the deed was done. A complete report, with pictures, descriptions, and survey figures of the newly laid out course was sent to Washington and Paris, requesting official recognition.

It was a blistering June afternoon, not a fit day for flying, certainly not a day to set a speed record. The wind came bursting in from the white-capped Pacific, whipping the checkered pylon as it cut across the three-kilometer speed course. A red streamline Waco Taper Wing squatted at one end of the field, its struts whistling merrily. I was whistling, too, a few bars of "Come With Me, Josephine, In My Flying Machine," the same one over and over again. I climbed down from the cockpit, pulled off my helmet to talk with Joe Nikrent, who had left his timing equipment and hurried over to the ship.

"What do you think about the wind?" I queried.

"Frank, it's my guess the blow's over. Turn her over. When you're ready, give me the signal."

"Contact!" The red Waco roared to the line. "Good luck, kid," offered Frank Hawks.

"Keep her smooth over the course, and watch for any flutters coming out of the dives. You understand the international rules?" queried Nikrent. "Two loops west to east and return; east to west and return; four times over the course for average speed. Level off to one hundred and eighty-seven feet at the flags, and stay under that all the way. The flags are back one hundred meters from the course. Take her away, son—and tail winds."

Eager to be up where red-winged birds belong, the little streamlined ship stuck her nose into the wind, roared down the course, raised herself as lightly as a dancer, made a slow, climbing turn and headed off to the east.

Up, up—one, two, four, five thousand feet climbed the red bird. She poised, head up, tail down, as if on tiptoe, for a brief moment, then dropped her nose and screamed into a steep dive. I was watching the oil pressure, alive to the strains of ship and motor. The five-hundred-meter flags came charging up at me. "Now," I whispered to the ship. Slowly, I began to ease back on the stick and to level off, thirty feet above the ground.

Down the straightaway, hugging close to the course, giving her all she'd take. I wondered if the barograph, cradled in the compartment back of the cockpit, was functioning properly. The gas was O. K., just enough for the four laps and a ride back to the airport. The oil pressure was dropping slightly. What the devil!

We reached the east line, crossed it, zoomed as the five-hundred-meter flags were left behind. Two, three, four thousand feet. The ship was warm to her task. She peeled off, lowered her nose and went into a pretty steep dive, leveled at the flags and screamed into the east-west straightaway.

"The speed wing clipped that one off. What a swell rigging job Pacific Airmotive had done."

The first loop was negotiated. Stromberger and Badger waved; time satisfactory. I put her into a climb.

"Not so steep on the dive," I warned the Waco. "Level off three hundred feet west of the five-hundred-meter markers—then pour the fog to her."

The last lap of the final loop—east to west.

It was over. I knocked on wood, whispered, "thanks," and set the red bird alongside Nikrent and his timing device.

"Good kid," said Joe. "You set a world's land-speed record for juniors." He lifted out the barograph. "Unless the N. A. A. and F. A. I. (Federation Aeronautique Internationale) say no."

IT WAS nearing midnight at March Field, and the engine was turning over with throbs of expectation. Two years of planning and a longer period of dreaming lay behind each staccato explosion in the cylinder heads. I was to wing my way to the heart of Mexico with letters from the Mayor of Los Angeles and the Governor of California for President Cardenas; later, I was to fly letters from Cardenas to the White House—if all went well—a total of nine thousand miles. The date was October 6, 1935, and the plane was *Yankee Boy*, a ship which had already demonstrated its (Turn to page 89)

# Pictorial History of Man in the Air

**1903 ON DECEMBER 17, THE FIRST CONTROLLED POWER-DRIVEN AIRPLANE TAKES THE AIR! HUMAN FLIGHT HAS AT LAST BEEN MADE POSSIBLE BY THE WRIGHT BROTHERS OF AMERICA! ORVILLE WAS THE PILOT OF THE FIRST FLIGHT OF 12 SECS. AT KITTY HAWK, N.C., ENDING THREE YEARS OF EXPERIMENTS!**

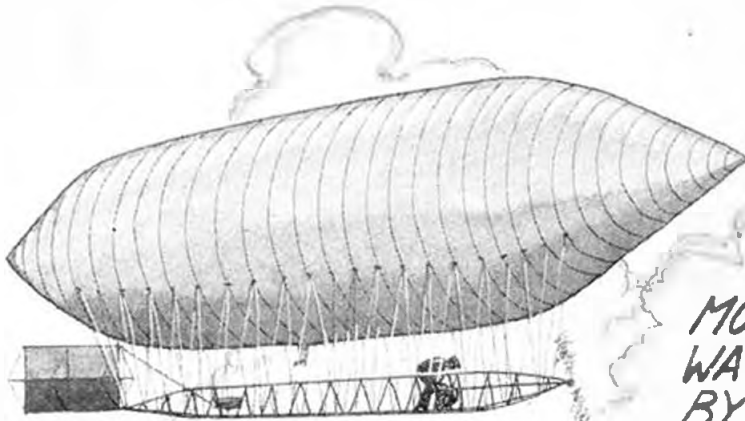
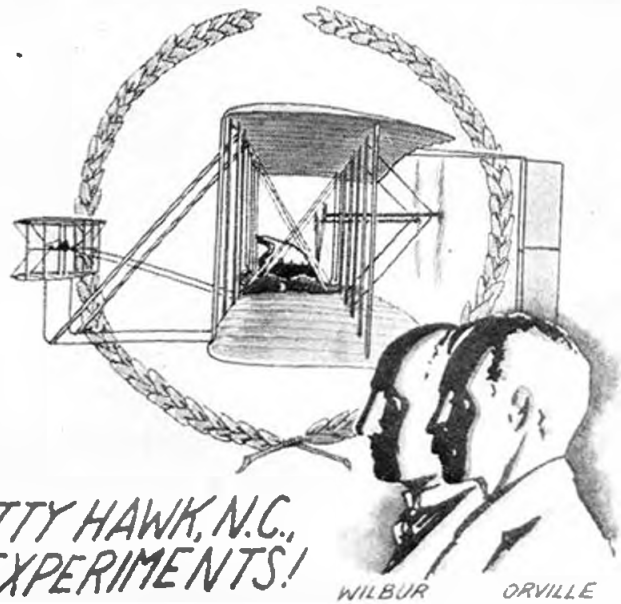

**1904 CAPT. T. BALDWIN, PRESENTS AMERICA'S FIRST PRACTICAL "BLIMP" DRIVEN BY A CURTISS MOTORCYCLE ENGINE, IT WAS A SENSATION FLOWN BY PILOT LINCOLN BEACHEY**

**1905 PROF. JOHN J. MONTGOMERY BUILDS A REMARKABLE NEW TANDEM MONOPLANE GLIDER. LIFTED BY A HOT AIR BALLOON AND CUT LOOSE AT 4,000 FT. THE PILOT**



**WAS ABLE TO PERFORM AMAZING MANEUVERS WITH A GRACE AND CONTROL NEVER BEFORE THOUGHT POSSIBLE.**



FROM—STEVE STERLING,  
Skyways Air School,  
Greenville, Calif.

"Dear  
Harry—"

TO—HARRY REED,  
Burton, Penn.

DEAR HARRY,

Open wide your ears and listen to the story of the big air race!

Here goes.

To make the story complete let me first explain that there are two students at this field who are regarded as outcasts. The two students are Kelvin and myself. According to the rest of the fellows we are a pair of reckless saps who are trying hard to get ourselves killed and are giving the school a bad name at the same time. The main reason for this belief dates back to the time Kelvin and I went joy-riding when I was supposed to be grounded, when Kelvin shouldn't have been carrying passengers, when Norwood sent eight ships in pursuit of us and notified the police, and when we two "outcasts" came near extinction in a forced landing.

Anyway, such is the case, and I am, therefore, greatly surprised when Crosby, who is a sort of leader among certain of the other students, invites me to enter an air race which they are getting up.

I had heard about this race beforehand. It is to be a jaunt from Skyways Airport to Hartland Airport, and the school training planes are to be used for racers. As they are all ships of the same make and type and are equipped with motors of the same power, the race will, naturally, be a pretty even thing.

"What do you say?" Crosby inquires. "Want to be in the race?"

"Why—sure," I reply.

"Fine," he says. "We're drawing lots to see who gets the different planes. Come along."

And so a few minutes later I am in on the drawing.

Apparently by prearrangement everybody puts his hand in the hat and takes a slip, after which the hat is passed to me.

I pick out the last slip and look at it, and

## Letters of an Air Student to His Friend

No. 4

by George Swift

simultaneously the silence is broken by roars of laughter from the others.

It doesn't take me long to guess why. My slip reads No. 7, which means that Training Ship No. 7 will be my race plane, and which also means that my chances of winning the race are about 1,000,000,000,000

to 1. This is because No. 7 is one of those ships which are known as "lemons." Although the mechanics have torn down the motor and thrown it together numerous times, they have never been able to find out what is wrong with it. It is lousy, slow, and will never be otherwise.

Of course, I realize now that the drawing was a put-up job by Crosby and his gang.

I eye them silently as they split their sides with shrieks of mirth. I notice that Norwood, who has been standing near watching the drawing, is not laughing. However, even though he knows the thing was fixed, as it is all in fun he cannot very well interfere.

An idea occurs to me.

Believe it or not, even as I face that gang of hyenas I think of a way to beat them at their own game.

"Just a minute," I interrupt. "I want to thank you boys for letting me in on your race. (Turn to page 88)

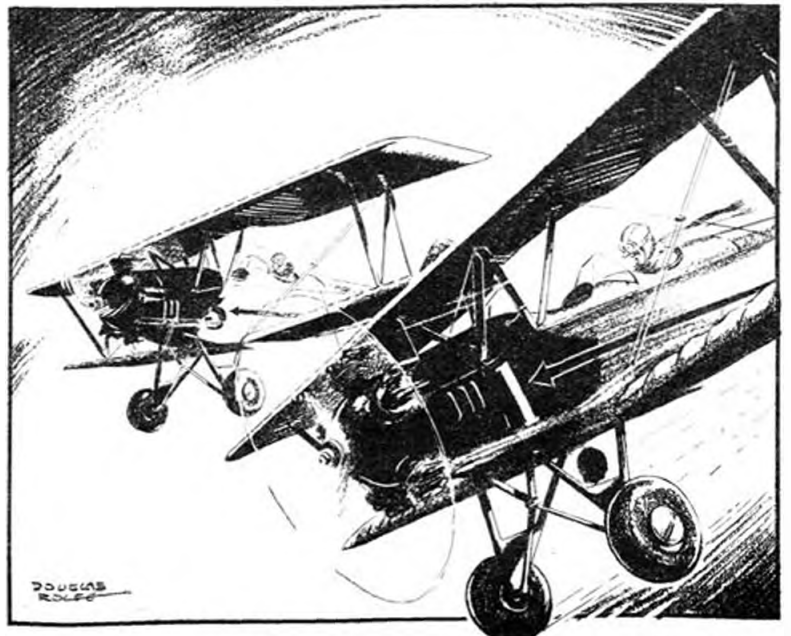

We were practically neck to neck—and I was gaining!  
And they thought they'd handed me a "lemon"!

# SPLIT-SECOND ACTION

*Hair-breadth escapes, hair-trigger decisions, dangerous moments that come once in a lifetime.*



THE LOS ANGELES STOOD ON HER NOSE AND SURVIVED! WHILE MOORED AT LAKEHURST A SUDDEN CHANGE IN WIND DIRECTION LIFTED THE STERN OF THE AIRSHIP TO A 90 DEGREE ANGLE. QUICK ACTION BY THE GROUND CREW AVERTED DISASTER.



JON L. BLUMMER



IN NICARAGUA LT. FRANK SCHILT MADE TEN ROUND TRIPS IN BAD FLYING WEATHER AND UNDER CONSTANT FIRE FROM GENERAL SANDINO'S REBELS TO RESCUE EIGHTEEN WOUNDED MARINES TRAPPED IN A SMALL ADOBE TOWN. HE USED THE TOWN'S MAIN STREET AS A LANDING FIELD.



MAJOR H.M. HICKMAN, IN JUMPING FROM A PURSUIT PLANE AFTER A MID-AIR COLLISION, CRASHED INTO THE TAIL GROUP AND WAS KNOCKED UNCONSCIOUS. HE REGAINED HIS SENSES TO FIND HIS PARACHUTE OPEN. HE FLOATED TO SAFETY THOUGH NEVER ABLE TO RECALL PULLING THE RIP CORD.

AL WILLIAMS ONCE FLEW A PLANE TO COMPLETE DESTRUCTION TO LEARN WHY THE TYPE KILLED SO MANY PILOTS.

# The REAPER

by Frank  
Tinsley

*Mars gets a new sword—*

*The plane on the cover—Fokker's G-1*

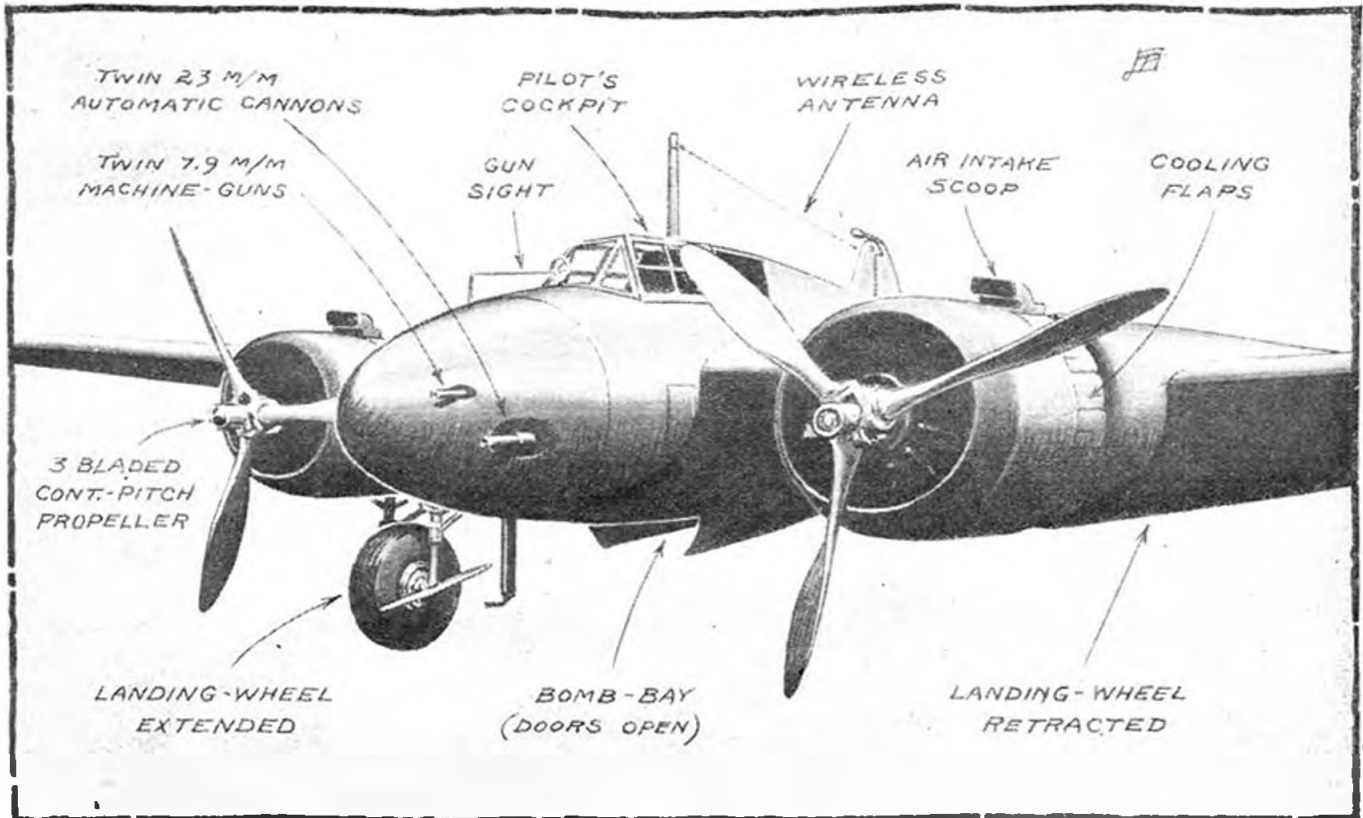

A front quarter view of the Fokker G-1 attack bomber reveals its formidable armament.

**A**NTHONY FOKKER has done it again. The "Flying Dutchman's" new bimotored fighter, named the *Reaper* and exhibited for the first time at the 1936 International Air Show in Paris, proves anew that the businesslike little airplane designer from the shores of the Zuider Zee is still one of the most progressive aeronautical engineers of his time.

In originality of design and equipment, the new Fokker G-1 is just as far ahead of current two-seater fighters as his famous D-7 outstripped its rivals in 1918. And those of you who have studied World War planes will remember the D-7 as the most advanced and efficient fighting machine of the War. Square-cornered and ugly in appearance, this most famous of all Fokkers was a forerunner of modern steel tube and cantilever construction. Swinging like the scythe of death across the war-torn skies of northern France, the D-7 was feared and admired by Allied pilots, and must have caused many a bitter reflection on the part of the high and mighty British officials who, in the early days of the War, rebuffed the little Hollander's offer of his services. Turning to a more receptive Germany, Fokker produced a long series of military aircraft which were always a jump ahead of their French and English opponents in fighting efficiency. Tony was the first to conceive and design the machine-gun synchronizing

gear which enabled a Saxon pilot named Boelcke to blast forty Allied planes to earth and become the first great pursuit ace of the War.

From the alert brain of the Flying Dutchman tumbled a continuous stream of original and highly practical ideas which speeded up the development of the airplane to an enormous extent. His War-time achievements culminated in the D-8, a monoplane scout nicknamed the *Flying Razor*, which appeared on the western front just prior to the armistice. This remarkable machine was the granddaddy of the high-wing, cantilever monoplane of to-day and was years ahead of its time.

During the period following the War, Fokker turned his inventive genius to the problems of commercial aircraft design. Beginning with his famous old single-engined Universal and Super-Universal transports he graduated to bigger and bigger multimotored ships. These were widely used by American and foreign air lines during the late twenties. With the advent of the first low-wing, all-metal Douglas, the redoubtable Tony again demonstrated his mental receptiveness and Dutch commercial instinct. Quick to recognize a new and better mousetrap when he saw one, Fokker promptly acquired the foreign sales rights to Donald Douglas' brain child and proceeded to sell the speedy American machines all over the world.

During this period the designer again turned his attention to military ships and built a series of war planes of various types for the Netherlands air force. These ranked with the best foreign planes of their kind. Among them was a series of single-seater fighters designed around British Rolls-Royce engines.

These little-known ships closely resembled the famous Hawker Fury both in appearance and performance. Late in 1935 he switched from the biplane form and turned out a low-wing, cantilever monoplane fighter. This was the D-21, a single-seater with an inclosed cockpit, adapted to a variety of engines ranging from six hundred to eleven hundred horse power. Fitted with a Hispano-Suiza 12Yers liquid-cooled engine and retractable landing gear, the D-21 had a high speed of two hundred and ninety-five m.p.h., which placed it in the front rank of that year's pursuit ships.

Realizing the need for greater fire power and performance in the pursuit category, Fokker took his slide rule in hand and, after wrestling long and hard, produced an unusual answer to the problem. It is the G-1, the plane which appears on the cover. Two seven-hundred-and-fifty-horse-power, air-cooled radial motors furnish a volume of power that is extraordinary in this class of ship and is exceeded only by the new twin-motored Curtiss attack plane. A nacellelike fuselage combined with a tail unit supported on cantilever outriggers provides an unusually wide field of fire for the rear gunner. This, added to the tremendously powerful battery of fixed guns in the nose of the machine, gives the plane its name: the *Reaper*.

The G-1 is a cantilever monoplane of the mid-wing type. This placement of the wings in relation to the engine nacelles and fuselage presents the best junction from the aerodynamical point of view. Turbulence of air flow has been reduced to a minimum. The wing

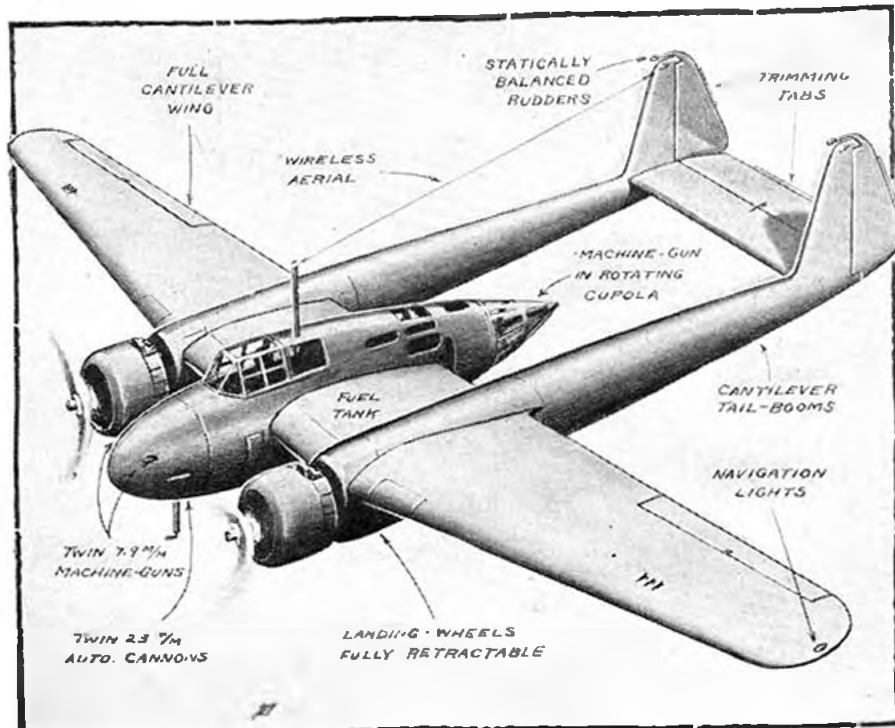

This self-explanatory view of the G-1 shows the unorthodox design with many innovations.

is constructed in three sections and is built up of two box spars of spruce and plywood, combined with plywood ribs. The covering is also of Bakelite plywood, with the fibers running across each other diagonally for greater strength.

A smooth, highly polished surface cuts down skin friction. At the extremities of the center section of the wing are reinforced structures to which are anchored the engine mounts and the tail booms. Two strong box ribs support the engine bearers and form the walls of a compartment between the spars, into which the landing wheels retract.

The ailerons are of chrome-moly steel structure, fabric-covered. They are statically and aerodynamically balanced and are operated by cables. Air-brake flaps extend between the ailerons and the tail booms and between the booms and the fuselage. They are operated hydraulically and materially reduce the landing speed of the ship.

The central portion of the fuselage is of monocoque wood construction attached to the two master ribs. The space between the spars forms an internal bomb bay. The pilot's seat is placed just forward of the front spar and is adjustable vertically during flight. The rudder pedals are adjustable horizontally. Springing from the spars is a braced pylon of welded chrome-moly steel tubes, for the protection of the pilot in the event of a nose-over.

The nose of the fuselage is constructed of heavy steel tubing bolted to the master ribs. This structure supports the gun mounts of a fixed battery, consisting of two 23mm. cannons and two 7.9mm. machine guns. These are operated by the pilot. The cannons are air-cooled, belt-fed, function automatically and have a muzzle velocity of one thousand nine hundred and sixty-eight feet per second. This last is an important item in high-speed combat. The magazines normally hold one hundred shells. The principal

(Turn to page 91)

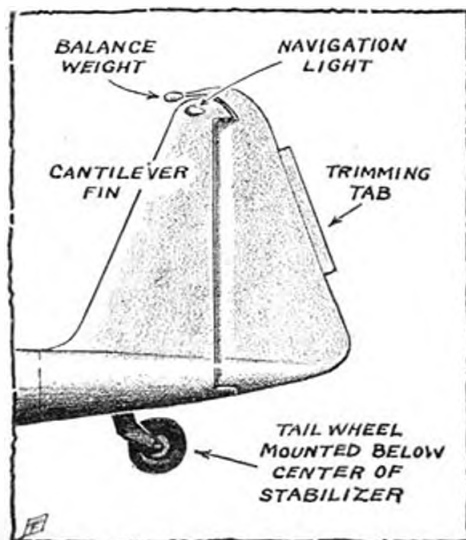

One of the twin, vertical tails indicating the fine streamline and pertinent details.



# MODERN MOTORS

Article Three

## The MODERN RADIAL Engine

by

Arch Whitehouse

and

Alexander N. Troshkin

*Guggenheim School of Aeronautics,  
New York University*

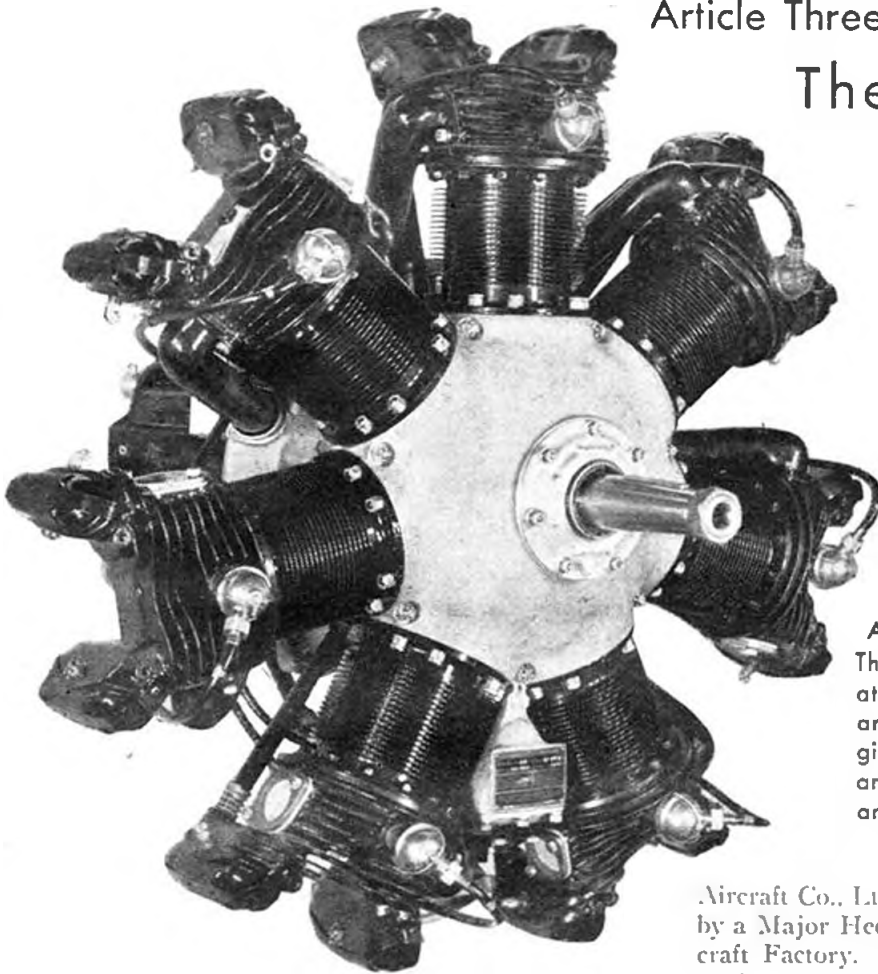

**A POPULAR AMERICAN RADIAL**  
This is the Warner super-Scarab, rated at 145 h.p., and most suitable for amateur flying use. Many of these engines are used on light planes. They are considered very economical to run and comparatively simple to service.

**L**AST MONTH we probed into the mystery of the old rotary engine and studied its cycle of motion. We learned that it had certain vices and many fine qualities. We also learned that the rotary engine was not able to keep pace with aviation because of the difficulties encountered in attempting to raise the horse power much above 200.

During the closing months of the War, the rotary was fast losing its position to comparatively light water-cooled engines of the Hispano-Suiza, Liberty, Rolls-Royce, and Sunbeam type. The British had shoved the Bentley rotary up to about 250 h.p., but the handwriting was on the wall. The two-seater fighters were almost as fast as the scouts, and the designers were confining their efforts toward more of the Bristol Fighter class. Sopwith was using the Hisso in his Dolphin and getting 121 m.p.h. with six guns aboard. The Vickers F.B.H-16 was doing 147 with the 300 Hisso, and the S.E.5 was more than holding its own against anything in the air. Bristol Fighters were driving the Fokkers out of the sky. Then came the news of the Nieuport Nighthawk.

Few to-day realize what this ship might have meant, had the War continued another 6 months. It was a scout biplane fitted with an engine that was totally unknown in the R. A. F. Test pilots came across from England with the glowing stories of the Nieuport Nighthawk, a new craft built by the Nieuport and General

Aircraft Co., Ltd., of London. It was built and designed by a Major Heckstall-Smith, formerly of the Royal Aircraft Factory. It was built to R. A. F. order and intended as a new basic type to end all single-seater designs. It was also built to use up much material already available, such as S.E.5 wings and other stock fittings, tons of which had piled up in various aircraft centers.

At any rate, the Nieuport Nighthawk did 151 m.p.h. using an A. B. C. Dragonfly engine rated at 320 h.p. The Dragonfly was a radial.

It should be explained, also, that Sopwith had bought a number of these radial engines and had fitted them into several Sopwith Snipe models. In the right hands, these Dragonfly Snipes actually did 152 m.p.h.

At first few believed that a radial engine could be built to turn out such power or anything like it. They remembered that Bleriot used a 3-cylinder Anzani radial when he flew the English Channel and that for years after they had tried to boost the h.p. up over the century mark, but only succeeded in reaching 80 with 10 cylinders.

The big trouble encountered, was the problem of cooling. In the rotary, the whirling motion of the engine provided a reasonably complete air stream about the cylinders; but in the stationary radial, air was only directed on the front of the cylinder barrels, and considering the speed attained, not a great deal of that.

For this reason then, the rotary displaced the radial during the greater part of the War, and it was not until a private firm in Great Britain actually showed that a radial engine, of suitable power output could be built, that this type came into its own.

The A. B. C. Dragonfly was a 9-cylinder motor with an output of 320 h.p. or producing about 2 lbs. for each lb. h.p. They were ordered in large numbers by the British for their Nieuport Nighthawks and one or two other types. Fortunately the War came to an end late in 1918 and by that time one or two major defects were discovered in the Dragonfly. First, they could not maintain their rated h.p. for any length of time; the distribution of the mixture to the various cylinders was very uneven, and rough running was the result. This naturally brought crank-shaft fractures and other breakages and again cooling raised its ugly head. They were having difficulty in cooling the cylinder heads, and manufacturers had not attained the skill of handling aluminium as they do to-day. There was considerable difficulty in attaching aluminium fins to the heads. The present universal practice of inserting steel valve seats into aluminium heads was not fully considered. They attempted to weld aluminium fins to the cylinder head, but the contact between the base of the fins and the head was not well done and the fins failed in their purpose.

This failure of the A. B. C. radial engine put the design

in ill favor again, and the manufacturers once more turned their attention to the development of high-power, water-cooled engines. At least they did in Europe. But here in the United States there was still a small group that believed in the radial.

Charles L. Lawrence, designer of the famous Wright Whirlwind engine was among these, and his efforts were well rewarded in 1927 when so many record-breaking flights were successfully carried out with planes using these motors. Colonel Lindbergh first put the Whirlwind on the map when he made his notable nonstop flight from New York to Paris. Clarence Chamberlin used it; Admiral Byrd used it. Among other well-known names that selected the Whirlwind for their distance- and record-establishing flights were Brock and Schlee, Maitland and Hagenberger, Captain Wilkins, Kingsford-Smith, and many others.

Lawrence had solved all the cooling problems and produced maximum efficiency in his J5 motor. He had been careful to begin with a comparatively light-powered motor. He was satisfied, first of all, to prove that the radial was a worthy addition to aviation. He gave 220

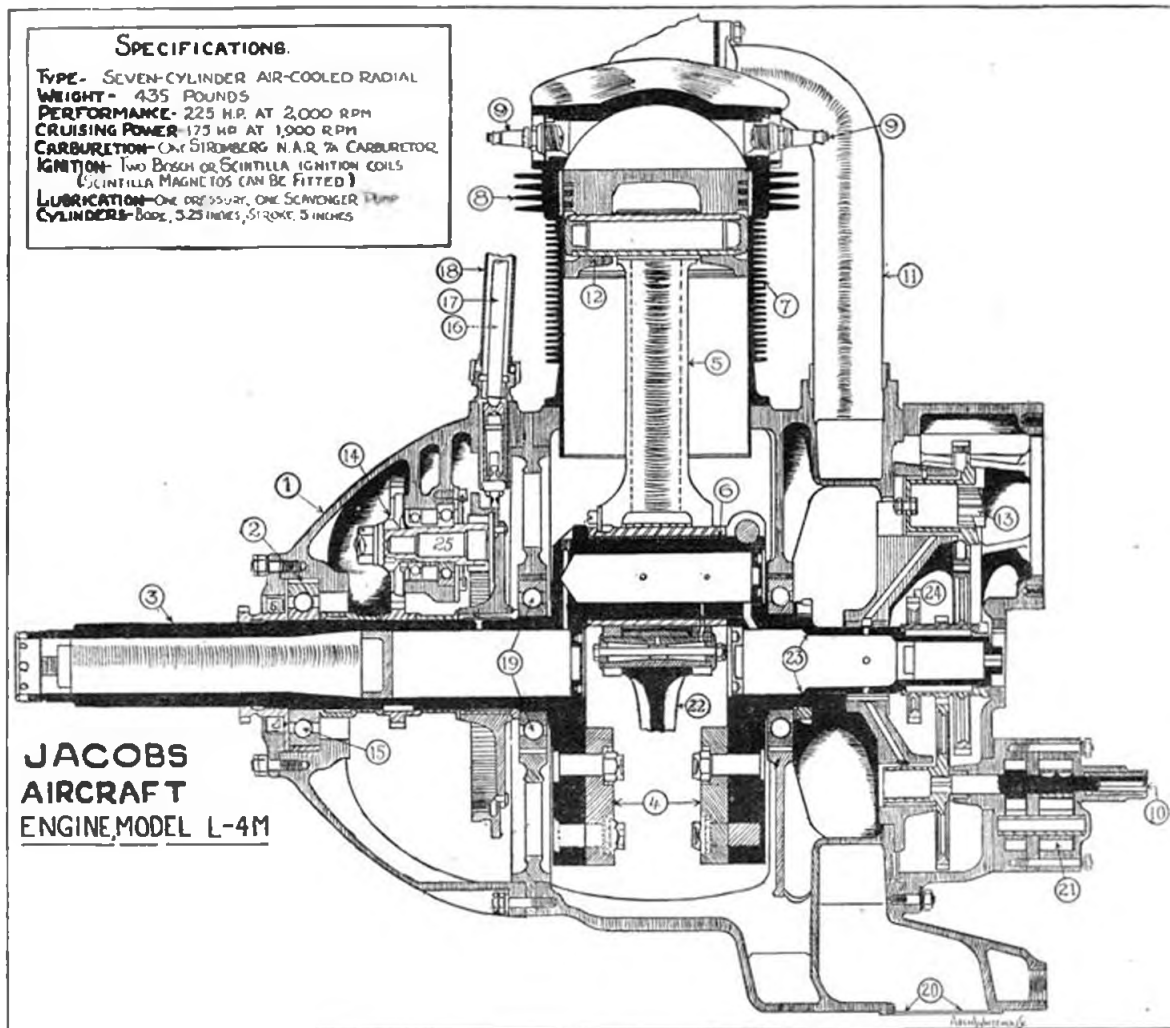

**JACOBS AVIATION ENGINE, MODEL L-4M**

Key to most important parts: 1: Front case. 2: Bearing liner. 3: Crank shaft (front half). 4: Crank shaft counterbalance weights. 5: Master rod. 6: Master-rod bearing. 7: Cylinder barrel. 8: Cylinder head. 9: Spark plugs. 10: Oil-pump drive shaft. 11: Intake pipe. 12: Piston. 13: Starter jaw and gear. 14: Cam drive spur gear. 15: Thrust bearing. 16: Intake push rod. 17: Exhaust push rod. (There are two push-rod tubes to each cylinder on the Jacobs engine.) 18: Push-rod tube. 19: Crank shaft main bearing. 20: Carburetor port. 21: Scavenger pump idler gear. 22: Link rod. 23: Crank shaft (rear half). 24: Magneto drive gear. 25: Valve gear shaft

h.p. in a plant that was easy to handle and service and economical to run. During 1928 the Wright Co. turned out 1,597 Whirlwinds, but the demand was far above the supply.

It should be stated here that almost at the same time the British Bristol Co. had been working on a radial which had been purchased from the Cosmos Engineering Corp., and they came out with the well-known Jupiter—which also performed well—and the radial was completely accepted.

There are some, of course, who will wonder why we have not mentioned the War-time Salmson, a French radial. Many American War-time airmen flew planes using these engines, but the Salmson was not an air-cooled radial. It was water-cooled, and so did not have to overcome the problems that later designers faced. Many valuable improvements in general radial design were first developed in the old Salmson. Mainly because it was water-cooled it could carry much heavier parts. If the truth were known, the Salmson firm deserves much credit for the general design of the modern radial master rod and crank shaft. After the War the Salmson firm gave up their old Canton-Umné design and went into the air-cooled radial business. To-day they make a radial-type, direct-injection, two-stroke engine which is water-cooled. But it is something of an experiment.

So to-day we see that the industry has leaped a great distance since Manly first designed a water-cooled radial for Professor Langley's airplane back in 1903. That strange contraption weighed 125 lbs. and produced 52 h.p., and even then was ahead of its time. Compare this, then, with the latest Wright Cyclone G-type engine which produces 1,100 h.p. and weighs but 1,068 lbs.

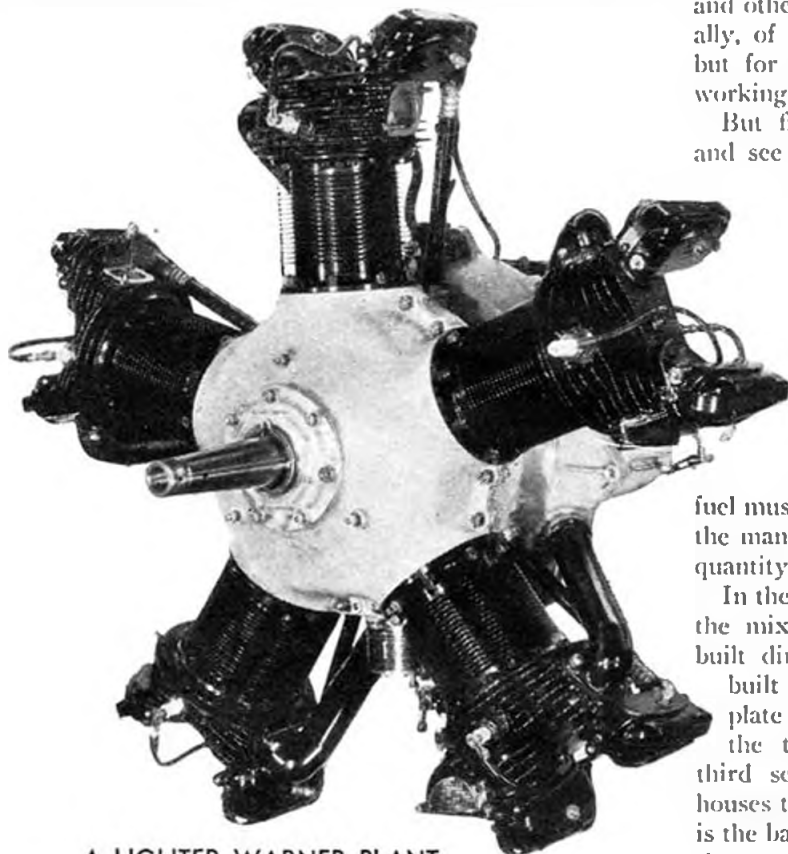

**A LIGHTER WARNER PLANT**

Another Warner product, the Scarab, rated at 125 h.p. at 2050 r.p.m. This is a neat and clean job, using only the finest of accessories.

Whether they are approaching their limit in h.p. in radial design is a matter that is the subject of much controversy. Many have believed that 1,000 h.p. would be the peak in radial power, but the 1,200 h.p. engines of to-day and the 1,500 h.p. which will be obtained this year makes the peak look a long way off.

But what is a radial engine and how does it differ from the rotary and the in-line type which we have studied so far? In appearance it looks like the rotary, as it has its cylinders mounted in a circle around a main crank case. But unlike the rotary, the radial is a stationary engine, on which the crank shaft revolves and not the whole bank of cylinders.

Thus the radial engine is considered a static motor. It may use 3, 5, 7, 9, and even as many as 14 (double row) cylinders on a single crank. Thus it gives compactness and light weight and does not produce the high gyroscopic force faced in rotary-motor operation. It does not present any particular difficulties as far as lubrication or carburization is concerned and aluminium can be widely used in the crank case. In rotary motors, where stresses are high, chrome steel had to be used, which was much costlier and excessively heavy.

This month we have selected the Jacobs radial engine, the L-4M type as our basic type to explain the working of the radial engine. This motor is made by the Jacobs Aircraft Engine Co. of Pottstown, Pa., and the company has been very generous in giving the writers full details and information on their products. The accompanying drawing was made from illustrations available in the Jacobs Instruction Manual.

The drawing shows the general arrangement of the crank case, crank shaft, master rod, valve gears, piston, and other parts in relation to the No. 1 Cylinder. Actually, of course, the Jacobs engine is a 7-cylinder plant, but for simplicity we show only one cylinder and the working parts connected with it.

But first let us look into radial-engine fuel systems and see how the vapor gets from the carburetor to the cylinder. The carburetor is mounted at the lower part of the crank case at the point 20. Gasoline is vaporized in the usual manner and sucked up through a series of mixture-supply passages built into the crank-case walls. From there it is drawn into the intake pipes and through the intake valve to the combustion chamber, where it is fired by a spark plug and starts the normal power stroke.

The fuel system in radial engines demands the finest of skill and ingenuity in design, for fuel must be prevented from settling in the lower parts of the manifold and at the same time be delivered in equal quantity to all the cylinders.

In the Jacobs engine, a typical motor of the radial type, the mixture-supply passages and mixture annulus are built directly into the crank case. The crank case is built up of 6 parts. First there is a thrust-bearing plate and then a magnesium-alloy front case carrying the thrust-bearing and valve-operating gear. The third section is made of aluminium-alloy casting and houses the front crankshaft bearings. The fourth section is the barrel-type aluminium-alloy casting which supports the rear crank shaft and incorporates a ring-type intake manifold. The fifth section carries the rear plate, which supports the accessory drives, etc.; and the sixth is a magnesium-alloy accessory cover. (Turn to page 92)

# What's Your Question?

## By CLYDE PANGBORN

### Wing Commander



As soon as possible after the questions are received, the Wing Commander of the Air Adventurers will answer on this page such questions as appear to be of general interest to our members.

*Question: Please explain to me what a snap-roll is and how to do it. I have heard that this is the hardest aerial maneuver to perform. Is this so? C. R., Fort Wayne, Indiana.*

**Answer:** As I have explained before, every type ship has slight differences in the required control movement for the various stunts. The reason for these differences will be found in the power, speed, wing-surface area and control-surface area obtainable on various types.

The snap-roll is not particularly hard, but it demands certain precision in execution. The plane is put into level flight, keeping your eye on a guiding point like a track or road. Pull back on the stick and apply full right or left rudder, depending on the direction of rotation desired. Once the plane has started to rotate, it will be noticed that it will display a tendency to continue. The instant you sight your marker again, you reverse your controls until the plane is in level flight again. The skill comes in timing this change of controls so that normal forward flight is resumed the instant your wings are parallel with the horizon.

*Question: What is propeller torque? I have heard this term used often, but no one seems to be able to explain it to me. J. R. Margate, New Jersey.*

**Answer:** Propeller torque is the tendency of a whirling propeller to turn an airplane about its longitudinal axis in a direction opposite to that in which the propeller revolves. Surely you have noticed this power in your rubber-powered model airplanes.

*Question: Could an American citizen enlist in the British Royal Air Force? D. M., Racine, Wisconsin.*

**Answer:** No. Only British subjects born of British-born parents are accepted in the Royal Air Force during peace time, at least. Many Americans joined the Royal Air Force during the Great War, but they had to temporarily relinquish their American citizenship and swear allegiance to the British Crown for the duration of the War.

*Question: Can you tell me anything about a plane called the Eastman Flying Boat? A. B., Goderich, Ontario, Canada.*

**Answer:** You no doubt refer to the Eastman Fly-

ing Yacht, built in 1930 by the Eastman Aircraft Corporation of Detroit. The company is no longer in business. The Flying Yacht was a four-seater flying boat powered with a 170 h.p. Curtiss *Challenger* engine. It was a single-bay sesquiplane in design, and the engine was mounted as a tractor in the upper-center section. The hull was built of duralumin and had a single step. Its top speed was 112 m.p.h. and it cruised at 90.

*Question: Which of the opposing forces in the World War shot down the most enemy aircraft, and what single country is credited with the most? R. T., Augusta, Ga.*

**Answer:** Your question is almost impossible to answer, owing to the unreliability of the available records. German records claim 6,794 Allied airplanes totally destroyed. They admit to losing 8,513 airmen, but how many planes has never been given out. French losses were 5,353 airmen (no details of planes) while they claim to have destroyed 2,962 planes and 347 observation balloons. The American figures are 781 enemy airplanes and 73 balloons destroyed for a loss of 289 airplanes and 48 balloons. The British figures are not available because no records of aerial combat results were kept prior to July 1st, 1916. The figures compiled after that date appear to show British superiority in the air. In that time, on all fronts, including Italy, Egypt, Salonika, Palestine and Aden, the Royal Flying Corps and the Royal Naval Air Service claim 7,908 victories and 258 balloons against total losses of 2,810. It will be seen, of course, that a cross checking of these figures indicates that there are glaring discrepancies somewhere.

*Question: Where can I obtain full information on the Aeroneer 1-B shown in the Air Trails magazine a short time ago? E. L. K., Celina, Ohio.*

**Answer:** The Aeroneer machine is still in the experimental stage, according to the latest from the Aero Engineering Corporation of Los Angeles, California. The 1-B is a two-seater light cabin monoplane of low-wing design. The wings and fuselage are all metal and a 125 h.p. Menasco motor is used, which is said to give the ship a top speed of 147 m.p.h. The above address will reach the company and they will be glad to send you further details.



## MARCHING ON!

**T**HE AIR ADVENTURERS are marching on! The sky's the limit and there's no limit to the sky. You can't go wrong, for we are on the threshold of the most glorious organization future. If you haven't sent in your membership coupon already, can you give yourself one—just one—logical reason why not? You owe it to yourself and you owe it to your country. The future of the world is in the air and you can't stay out of the hangar.

We were talking to an old-timer the other night at the Quiet Birdmen meeting, and showed him the general set-up of our Air Adventurers' club. He listened intently for some time and finally said, with a whimsical smile, "What a break these youngsters get to-day! You're practically handing them a first-class course in aviation. I remember back in 1911 when I tried to get some information on flying. There was one book out, written by a Frenchman, or an Englishman; it doesn't matter now, but it cost about \$18.00. Where was I to get \$18.00 in those days? It took me 4 years and about \$3,000 in time to learn even the most simple laws of aircraft design and a spotty theory of flight. Do you know that had I been able to answer 70 per cent of the questions you are offering your readers, I would have been head of the air service back in 1915?"

The old-timer said more in those few words than we could put together in a week, but it reminded us of one point: The examination-question list for the various ranks, which will be in the mail soon, will demand a certain amount of research and study. This will be no cheap circulation stunt. When you get past a grade in the Air Adventurers' club, you will have learned something.

The questions will cover all phases of aviation, and this month we are going to tip you off to a few easily obtained books that will help you.

First, for modern records, details and information on record flights, statistics and figures on air strength of various nations, we heartily recommend the popular "World Almanac." It is cheap and available at most news stands.

Volumes on technical subjects, such as motors and rigging, may be obtained at the Ronald Press Co., 15 East 26th Street, New York City: "Aeronautics," by Hilton F. Lusk; "Engineering Aerodynamics," by Walter S. Diehl; and "Airplane Design," by Warner, published by McGraw-Hill Book Co., of 330 West 42nd Street, New York City.

One of the best all-around books on modern aviation is Assa Jordanoff's "Your Wings," published by Funk and Wagnalls Co., of 354 Fourth Avenue. It is listed at \$2.50 and is well worth it, for it contains the most up-to-date information on transport flying, acrobatics, instruments, aviation and radio. The drawings by Frank Carlson are particularly instructive.

The "Aircraft Year Book," published by the Aeronautical Chamber of Commerce, is a fine annual volume which should be available in all first-class city libraries. Those living in the large cities may be fortunate enough to gain access to Jane's "All the World's Aircraft," an annual publication offering photographs and details of all planes, motors and airships produced each year.

Model makers are all acquainted with the "Complete Model Aircraft Manual," written by Edwin T. Hamilton and published by Dodd, Mead and Co. War and historical data may be obtained from "Fighting the Flying Circus," by Rickenbacker; "Flying Fury," by James McCudden, V. C.; "German War Birds," by Vigilant; "Days on the Wing," by Willy Coppens; and "Falcons of France," by Nordhoff and Hall.

And, of course, if you have carefully filed your copies of Air Trails you will have a most reliable source of information at your finger tips.

We are all going to be very busy during the next few months, and sincerely hope you will not request all this information again.

But don't forget, this is the chance of a lifetime. You can't buy your rank in Air Adventurers and there's no such thing as pull. The examination will be drawn up and, as you wish to progress, you must fulfill all requirements.

We appreciate the fact that many of the books we

have mentioned cost money, and that we are not all in the position to purchase whole aeronautical libraries. But, for those who take up these examinations with the proper spirit and enthusiasm, we can recommend the good old method of personal research. Most of us live near public libraries, where may be found shelves carrying technical volumes. Most of these shelves will offer volumes which, if carefully inspected, will provide most of the details we require.



Photograph of a model Curtiss Hawk P-6 constructed by Air Adventurer Juan Martinez of Neptuno #90, Havana, Cuba.

There is a lot more fun in this sort of research, and a greater knowledge will be gleaned. Automobile handbooks carry information which can usually be fitted to aeronautical motor questions. Most good air-adventure stories will include, somewhere in the text, information on planes and airports. Most manufacturing companies, we have found, will gladly send illustrated catalogues of their products, if clean and neat requests are mailed.

You must learn to read for information as well as enjoyment, and we believe you will get just as much out of this practice as you would by writing letters to recognized aviation writers and presenting lengthy lists of questions.

None of them object to answering one or two straightforward questions, but they soon see through the business of hundreds of letters that come in, all asking the same list of questions.

Let's plug and dig this stuff out on our own hooks!

And another thing. I want these two pages to be the two most lively pages in the whole issue. There is a great deal of activity among members of Air Adventurers, and it is time we told each other a little bit about it.

The first picture that came in shows what one Cuban Air Adventurer is doing.

Take your camera along when you undertake to fly a model and see if you can't get a picture of it. When Air Adventurers get together they can take pictures of each other, showing what their activities are in connection with aviation. It will make you feel good when you see the notes and pictures begin to appear on these pages.

Applications for advancement are coming in very fast, and it will soon be necessary to devote some space to announcing the list of new lieutenants and captains. We also want to announce the list of those who have qualified for Craftsman Awards.

This information, of course, we will have here at

headquarters, but even so, when you get your awards it would be nice if we had snapshots and notes which tell us a little bit about each other.

In other words, I want the Air Adventurers themselves to help me conduct this department from now on. There are so many things you can write and tell me of interest; suggestions which might help aviation as a whole. Many of our members have formed themselves into local groups, and we would like to know what they're doing. It may be that I can find some item from among the notes you mail which will help other groups of Air Adventurers to get together.

Our organization has grown so fast that it has been impossible for us to keep pace even with the members who live in our own neighborhoods, and we want this department to serve as a clearing house for information which will serve the purpose of making Air Adventurers acquainted with each other.

You, as an Air Adventurer, may wish that there were other Air Adventurers close by. Perhaps there are available members who simply do not know about our organization. If there are, why not introduce them to it and in this way take your first step toward becoming a lieutenant.

Let them read over the February issue so that they may see what a real helpful organization we have, and you'll be surprised at the interest they will show.

You who aren't in the select circle clip that coupon, read it carefully. Read over the creed carefully. If you feel that you honestly agree with the purposes and principles of our club and can conscientiously live up to our 7-point creed (self-reliance, courage, initiative, loyalty, integrity, independence and obedience) fill in the membership application at the bottom of the page, and forward it, together with 10¢ for your wings.

If your application is approved, your certificate and wings will be mailed at once.

So, until next month then, we'll leave you to your problems. Remember, the sky's the limit!

Your Flight Commander.

*Albert J. Carlson*

#### (MEMBERSHIP COUPON)

To the Flight Commander, Air Adventurers,  
79-89 Seventh Avenue,  
New York, N. Y.

I am interested in aviation and its future developments. To the best of my ability I pledge myself to support the principles and ideals of AIR ADVENTURERS and will do all in my power to further the advance of aviation.

Please enroll me as a member of AIR ADVENTURERS and send me my certificate and badge. I enclose ten cents to cover postage.

Name ..... Age .....

Address .....

Check here if interested in model building.

(This coupon may not be used after May 15, 1937.)



Balboni displays his official city license.

RECENTLY I was commissioned by a museum to secure for them an old and obsolete type of aircraft engine, a Clerget rotary. I had exhausted every source of information when a friend suggested a call on Arrigo Balboni. A short distance from the heart of Los Angeles I located the office of Balboni and uncovered a mine of tragic and poignant memories.

But not all were tragic, for some were funny, others ridiculous. Balboni is the proprietor of the only "aerial graveyard" in the world. On a large plot of ground he has established the last resting place of the crippled, crushed, and broken aircraft of the last twelve years.

Balboni is as interesting as his weird collection of torn and twisted fuselages, wings, and engines. In 1924 Balboni had two hundred and fifty dollars, a dog, and a pilot's license. Then he saw an old Jenny that had an excellent coat of paint and not much else, and after a couple of looks he had a Jenny, a dog, and a pilot's license, and the flying business had acquired another barnstormer. The dog, Anna by name, was as essential to Balboni as the Jenny, because—of all things—Anna was a parachute jumper. Balboni barnstormed and Anna jumped during that year until the gods intervened and tossed a new profession into Balboni's lap.

On one of his barnstorming hops while Balboni was attempting to cross the Tehachapi Mountains coming into Los Angeles, his radiator froze and he was forced down. The plane crashed and was completely demolished. Balboni proceeded to Los Angeles by motor car and offered the wreckage for sale. The best bid was \$75. He did not consider this enough and he returned to the scene of the wreck with a truck and salvaged everything that could be gathered up. On his way back to Los Angeles he sold \$150 worth of parts from the wreck and upon arrival in the city, he canvassed the airports and eventually realized \$900 on the salvaged parts. He then conceived the idea of an airplane "graveyard." He still has the graveyard; it provides an excellent and interesting business, and Balboni has become known to pilots from one end of the country to the other.

by Lt. Commander  
George O. Noville

*The only "aerial graveyard," last resting place for wrecks, is haunted by the ghosts of gallant men and planes.*

# Tragic Memorial

The three lots which constitute his establishment are covered with row after row and pile after pile of ripped, torn, rusted, and shattered wings, fuselages, engines, tanks, pontoons and landing gears. In a corner are big pyramids of flying wires and guy wires that were borne, shrieking and screaming, on wings that plunged into the ground, some of them trailing streamers of fire behind. Rambling through these piles of debris, forlorn in their detachment, the progress of aviation can be vividly and accurately checked. In this wreckage any one familiar with aircraft can find fragments and parts of most of the old planes that made the headlines a few short years ago. Wings with old, familiar marking are stacked row upon row.

In one pile of wreckage lie the remains of the old Gee Bee racing ship in which, according to Balboni, three noted pilots were killed, Lowell Bayles at Detroit in 1931, Russell Boardman at Indianapolis in 1932, and Cecil Allen at Los Angeles in 1935 after he had rebuilt it. In another corner are the twisted, bent, and broken remains of the old Romair, built by Earl Ovington, the first air-mail pilot, in 1920. This group of tragic reminders has lately been joined by the most tragic of all ships, the Lockheed that carried Wiley Post and Will Rogers to an untimely death in the frozen wastes of Alaska.

Over 2,100 planes are collected in this vast mortuary, but wrecks are becoming increasingly scarce and with the rapid improvement in the design and construction of aircraft and aircraft engines this monument to the pioneering efforts of pilots and engineers may be relegated to the dim background.

In this collection may be found also the abortive efforts of the dreamers and visionaries, who financed and constructed weird and monstrous contraptions that would defy even the imagination of a Jules (Turn to page 95)

# CROSS WINDS

Can you answer the aeronautical definitions in this puzzle?

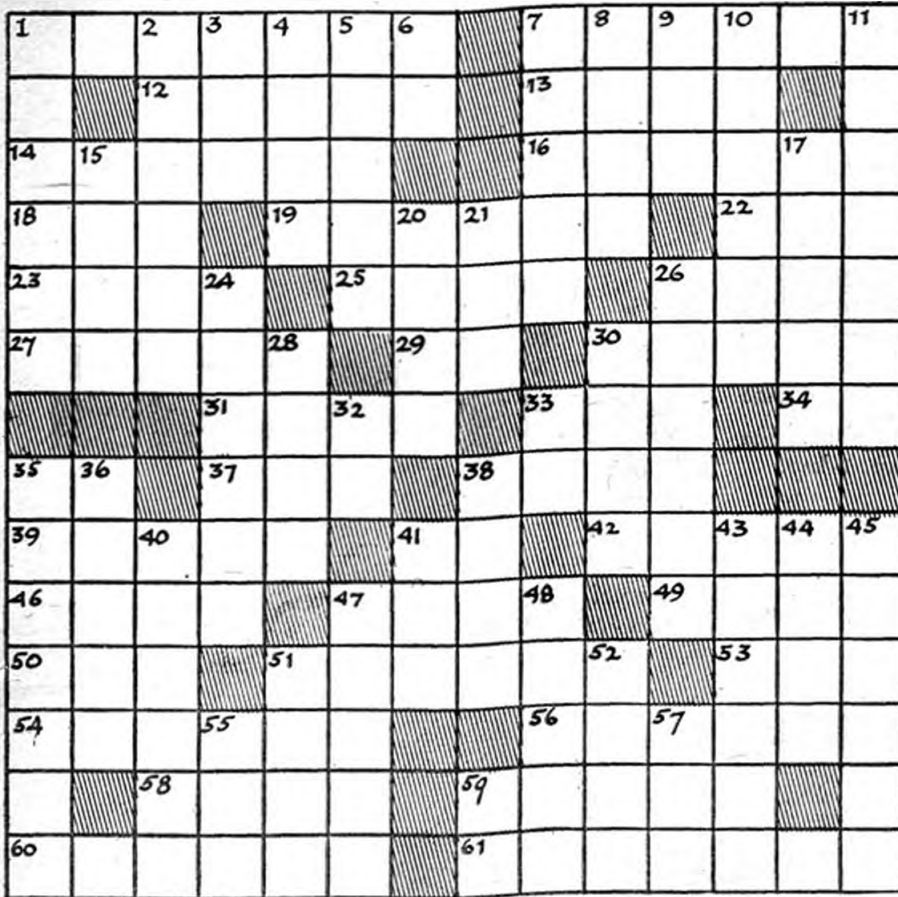

- 2—Uncommon thing
- 3—Air slang for bomb
- 4—Out of
- 5—Make of Czechoslovakia military planes
- 6—Old form of "you"
- 7—Place of contests
- 8—Window glass
- 9—To attach supporting wires on an airplane
- 10—Hateful
- 11—Make of lightweight U. S. aero engine
- 15—By word of mouth
- 17—Pertaining to birth
- 20—Peruse
- 21—Duration of existence
- 24—Arm joints
- 26—Cowboy's rope with running noose
- 28—Gape
- 30—Nearest
- 32—Concerning
- 33—Familiar term for father
- 35—Does a favor
- 36—Supporting structure
- 38—Shank of tool embedded in handle
- 40—Type of Hawker military biplane
- 41—Fall behind
- 43—Kind of flowers, known as flags
- 44—Parasitic insects
- 45—Detects by scent
- 47—Kind of medicinal plant
- 48—Biblical Arab tribe
- 51—Specifications
- 52—Be carried in a vehicle
- 55—Stomach
- 57—Period of time
- 59—Abbreviation for cubic centimeter

**Across**

- 1—Type of Fairey military biplane
- 7—Smooth area in front of hangar
- 12—To conform
- 13—Military foray
- 14—Fail to remember
- 16—Airplanes' source of mechanical power
- 18—Prefix meaning "three"
- 19—First word in name of noted French military-plane manufacturer
- 22—Kind of hardwood tree bearing acorns
- 23—Dislike intensely
- 25—Brilliant star whose name is given to a type of Lockheed plane
- 26—Stringed musical instrument
- 27—In a secretive manner
- 29—Make of Argentine plane
- 30—Pertaining to the nose
- 31—Poet
- 33—By means of
- 34—Suffix forming adverbs
- 35—Belonging to
- 37—Be indebted
- 38—Move a plane on the ground under its own power

- 39—Maker of the racing plane "Miss Los Angeles," and the B-3
- 41—Abbreviation of name of navy dirigible airship
- 42—Part of airplane that usually carries vertical and directional controls (plural)
- 46—Girl
- 47—Fuel container
- 49—Balance of aircraft or vessel in its supporting medium
- 50—Malignant spirit
- 51—Type of British Napier aero engine
- 53—Most perilous form of moisture condensation to fliers
- 54—Kind of round dance
- 56—Type of engine whose fuel is ignited by heat of compression
- 58—Devours
- 59—Staff of officers forming skeleton of a regiment
- 60—Figurative term for aerial route
- 61—Marks made by folding

**Down**

- 1—Two or more of five equal parts

**CROSS WINDS**

Answers for March

S	T	R	E	S	S	A	L	A	T	E	D
O	E	M	P	E	N	N	A	G	E	I	
A	W	F	U	L	E	N	O	R	M	S	
R	O	E	A	N	T	I	C	M	O	B	
E	R	R	A	T	A	C	E	S	S	N	A
R	R	V	S	B	E	R	N	O	R		
I	K	E				A	T	C			
U	S	R	H	O	A	S	K	O	S		
N	O	O	S	E	D	L	A	Y	O	U	T
I	M	P	R	E	B	E	L	A	P	O	
T	E	A	S	E	A	V	O	T	E	R	
E	L	A	T	E	C	O	E	R	E	M	
D	E	S	P	O	T	F	R	E	N	Z	Y



# AIR TRAILS GALLERY

*A Picture Page of Modern Planes for the Collector*



Northrop 2-J is the army's newest basic trainer. The engine is the Pratt & Whitney 450 h.p. Wasp.



The army's new nose-wheel amphibian is an experimental version of the Douglas Dolphin. The engines are Pratt & Whitney 450 h.p. Wasps. Note the position of the ship as it rests on all three wheels.



Giant 44-passenger Farman airliner is powered by 4 Knome Rhone 800 h.p. engines. Span is 118 feet.



Latest Norseman design built by Noorduyn Aircraft, Ltd., of Canada, 450 h.p. Wasp motor, has the usual Noorduyn landing-gear projections which support floats when attached.



Waco CUC amphibian is powered with 250 h.p. Wright Whirlwind engine. Floats are of Edo design with retracting wheels. Ship can be quickly converted to conventional landplane.



Al Williams' Gullhawk, a Grumman G-22, is similar to the navy's F3F-1. Power plant is the 935 h.p. Wright Cyclone.



The 4-engined Hamburger Flugzeugbau Ha-139 has been developed for the Deutsche Lufthansa. Despite its size, launching is to be done by catapult. This plane will be placed in the German transatlantic service to America.



# The MODEL WORK- SHOP



*Conducted by*

*Gordon S. Light*

**M**ODELS always reflect the personality of the modeler who builds them. If you inspect a model closely, or better still, watch the builder fly it, you'll have a cross section of his habits and his thoughts. In fact, every model I've ever seen had distinguishing characteristics which set it apart from all others. Here are some of the types I've noticed.

First, there is the "hot-house" variety of model. The design and construction of this model has been carefully carried out to the last detail. Indeed, the work has been done so beautifully it would be brutal to expose this model to the dangers of flying. But it's a pleasure to look at. And we've always marveled at the patience and workmanship necessary for such a job. But the careful workman responsible for its construction will not stand by and watch it crack up during the necessary test flights. Instead, the model will be given a place of honor on the mantelpiece.

It's a safe bet that the modeler who built this ship is methodical and painstaking. He'll not stop until every step in the construction is perfect. He works from full-size detail drawings, carefully planning every step. The "cut-and-try" method is too crude for him. He's probably a very slow builder, working on the same model for several months, giving it complete and thorough treatments before he turns to some new design.

Then there is the factory type of builder. He turns out a new model overnight. He makes up in numbers what his models lack in polish and refinement. This modeler is more interested in flying the model than making it beautiful. If it fails to deliver a good flight he is certain to dis-

## Personalities

card it and try some other design. It's not his nature to work out the problems that arise with each model. He never waits for good flying weather. As soon as the model is completed it is flown. With only a guess at the wing and tail settings the motor is wound and the model is launched. A good flight will probably inspire him to put in some additional work, smoothing out the rough spots. But, regardless of how successful the preliminary flights, the model will be discarded in a short time for a new model, which the builder is certain will fly much better.

This restless type of builder is almost certain to become a skilled modeler. His progress is marred by a path of wasted balsa and tissue, but through his hasty cut-and-try methods he stumbles upon some important advances in modeling which more conservative builders would never give a serious thought.

The rare specimen among modelers is the type who combines attractive appearance along with good flights. He delights in making his models realistic, but not at the expense of their flying ability and ruggedness. He is usually careful of his models. He'll keep them in the shop rather than expose them to the danger of gusty air or the menace of a tree-surrounded field.

The gadget expert is one type of builder that can't be omitted from this discussion. Give him an automatic stabilizer or a retractable landing gear to work with and he's happy. Straight-away flights do not appeal to him. To hold his attention the flight of a model must be accompanied by a parachute drop, a smoke screen, or automatic flap action.

At some time during one of your moments of daydreaming you might have *(Turn to page 94)*

## The Contest Calendar

**SECOND ANNUAL** Southern California Gas Model Contest. Awards to be made on point basis for precision and consistency of flights. Date: April 14th, 7 to 12 a. m. Entry blanks, information: D. S. Halacy, Secretary, Aviation Advancement Club, 4937 Vista Place, San Diego, California.

**FLYING SCALE** contest for beginners, all flights by proxy: Louisville, Ky., previously tentatively announced for February 26, finally fixed for May 7. Models to be judged 50% for flying ability, 50% for resemblance. Prizes of cash, kits, model materials. Rules, entry blanks: Fred Harwood, 1814 W. Burnett Ave., Louisville, Ky.

**1937 EASTERN STATES** Gas Model Meet. Sponsored by the Soaring Society of America, as a feature of the 8th Annual National Soaring Contest, July 5-9. Sanctioned by the N. A. A. Events include altitude, duration, and payload flights, also special events for multimotored, radio-controlled, and autogiro gas models. Trophies and cash awards. Information from Soaring Society of America, 1614 Delaware Ave., Wilmington, Delaware.

The Model Workshop asks the aid of readers and clubs in developing for their benefit a complete, detailed report of all model contests and exhibitions, large or small, everywhere. Listings should be received by The Contest Calendar, AIR TRAILS, 79 7th Ave., New York City, at least two months in advance; news of winners and results as soon as possible.

# The 1936 MULVIHILL WINNER



Bruce Lockett shown holding the Mulvihill Trophy after his triumph at Detroit.

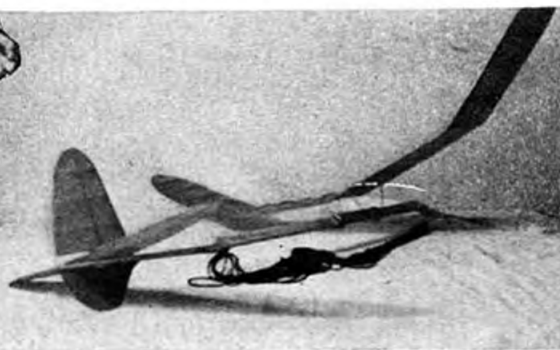

Above—A rear quarter view shows the distinctive rudder shape, parasol wing and tail boom arrangement. Right—The general design of the championship model is evident when seen from above.



Prepared by  
GORDON S. LIGHT  
*in collaboration with*  
BRUCE LUCKETT

**T**HE MULVIHILL is one of the most handsome of the National trophies. It is a bronzed figure of the mythical Greek hero, Icarus, testing his wings. Icarus met disaster when he flew too high and the sun melted the wax, which was holding his wings, and he fell into the sea and was drowned. The Mulvihill Trophy was a donation of B. H. Mulvihill, vice president of the N. A. A., in 1923. A yearly contest is held and the winner holds the trophy for one year. It's impossible to get permanent possession of the trophy, regardless of how often the same builder wins it. And since the age limit is 21, few modelers have the privilege of winning it more than once.

But to have your name inscribed on the trophy entitles you to a place on the honor roll of model building. Bruce Lockett of Tulsa, Oklahoma, was the 1936 addition. And this month we're privileged in being able to include the plans for his winning Mulvihill entry, along with some of his ideas and viewpoints on modeling.

Bruce can best describe this model and what features he tried to incorporate in its design. Here is a portion of his letter:

My primary purpose in building this ship was to produce a suitable plane to enter in the outdoor duration contest. The factors that I wished to put into this design were:

1. Good climb and a good flat glide to enable the ship to take thermals more easily.

2. To distribute the weight in such a manner as to make the ship both inherently stable and able to stand the punishment that outdoor contests are sure to inflict.

A plane with these features was produced only after ten months of experimentation on my part and the part of various other members of the Model Aeronautical Engineers of Tulsa. The following features were outstanding on the first ship: extremely high dihedral, low aspect ratio wing, fairly short moment arm, and a wing mounted rather high above the center of gravity. In the ships that followed several basic changes were made, as the above-mentioned features were far from ideal.

After many test flights with the following models I found it necessary to lower the dihedral, increase the aspect ratio of the wing, lengthen the moment arm, and also to lower the wing itself. The finished product far exceeded my expectations. It had an unusually flat glide and was very sensitive to thermals.

As a contest ship it proved to be a consistent performer and I was more than pleased with its performance. Three weeks prior to the 1936 Nationals held in Detroit, the plane was entered in a contest sponsored by the members of the Tulsa Airmen's Club. The plane placed third, with a flight of better than 15 minutes, and its second-best official flight was 10:50. Three weeks later this same model won the Mulvihill Trophy at the Nationals, with a flight of 41:41, making a 9:06 flight on its first official try.

And this is Lockett's very modest account of how a converted scale modeler set about to win an outdoor contest.

## ABOUT BRUCE LUCKETT

**B**RUCE LUCKETT is a scale modeler who was converted to the outdoor way of thinking about a year ago. In February, 1936, he made his first official flight at a club contest, winning second place. Next month, he did better, and won first place in the Tulsa *Tribune* contest. And then, after placing third in the Tulsa Airmen's club contest in May, he went to Detroit to win the Mulvihill Trophy with a flight of 41 minutes and 41 seconds. In addition, he placed fourth in the Moffett Trophy finals. Since then he's placed second in the gas event of the Tulsa State Fair contest and third in a recent club contest.

Bruce is just 17 and a senior in high school. Aeronautical engineering is his goal. At present he is a member of the Model Aeronautical Engineers of Tulsa, Oklahoma—one of the most active model clubs in the country. Already he's working on his models for this year's contest. He has no intention of giving up the Mulvihill Trophy. And what's more, he has his eye on one of the National indoor trophies. If he tackles the indoor problem with the same enthusiasm as he did outdoor modeling, the trophy is as good as in Tulsa already.

CONSTRUCTION

The model has the advantage of combining excellent contest performance, and yet its construction is well within the range of the beginner. This proves again that the most successful contest model is usually the simplest. Simplicity and efficiency go hand in hand in modeling, as in most other things. And, too, the model should be attractive to the builders who are working on a limited budget. The cost of the material is small, compared to the usual expense of duplicating a contest winner.

MOTOR STICK AND TAIL BOOM

Both stick and boom are triangular in cross section, built up from three pieces of flat sheet balsa. The construction procedure is to build a trough out of two pieces by cementing the edges together and then the third piece is cemented across the top, as cap. Hard-grade balsa is used in both stick and boom.

The motor stick is 18" long and uniform in cross section.  $\frac{3}{32}$ " sheet balsa is used. The edges of two pieces of  $\frac{3}{8}$ " balsa are angled so they fit tightly together and then joined with liberal coats of cement. The width of the trough or "V" formed by the two pieces should be  $\frac{3}{4}$ ". The edges of the "V" should be bevelled so they fit snugly against the cap strip which is  $\frac{3}{32} \times \frac{3}{4}$ ".

The tail boom is built the same way. It is 8" long and tapering. The cap strip tapers from  $\frac{1}{2}$ " to  $\frac{1}{4}$ " and the sides of the "V" taper from  $\frac{7}{16}$ " to  $\frac{3}{16}$ ".  $\frac{1}{8}$ " sheet

balsa is used and the thickness of the walls does not vary.

The stick is used with the cap strip on the bottom, whereas the boom is turned so the cap strip is on top. This provides a flat surface for mounting the tail surfaces.

The front of the motor stick is cut off at an angle, and a small piece of balsa is cemented to it to provide a solid base for attaching the thrust bearing. The bearing itself is bent from #20 wire. It extends up the front of the stick and over the top. To prevent the bearing from bending, it is reinforced with a piece of plywood. It can be either balsa or hardwood. However, it should be three-ply and at least  $\frac{1}{8}$ " thickness. The front of the stick is equipped with a thrust holder. It is a wire hook from #20 wire and cemented to the plywood. The hook should be the same level as the hole in the thrust bearing or just about  $\frac{1}{16}$ " below the bottom of the motor stick. This thrust holder can be bent to give the propeller any desired negative angle.

The rear hook is bent from #20 wire and attached to the rear of the stick. It is reinforced with plywood in much the same way as the thrust bearing. The center of the rear hook should be  $\frac{1}{4}$ " below the bottom of the stick.

The tail boom and the motor stick are butt joined. That is, the edges are cemented thoroughly and then pressed together, keeping in position until the cement has dried. Remember that the flat part of the boom is

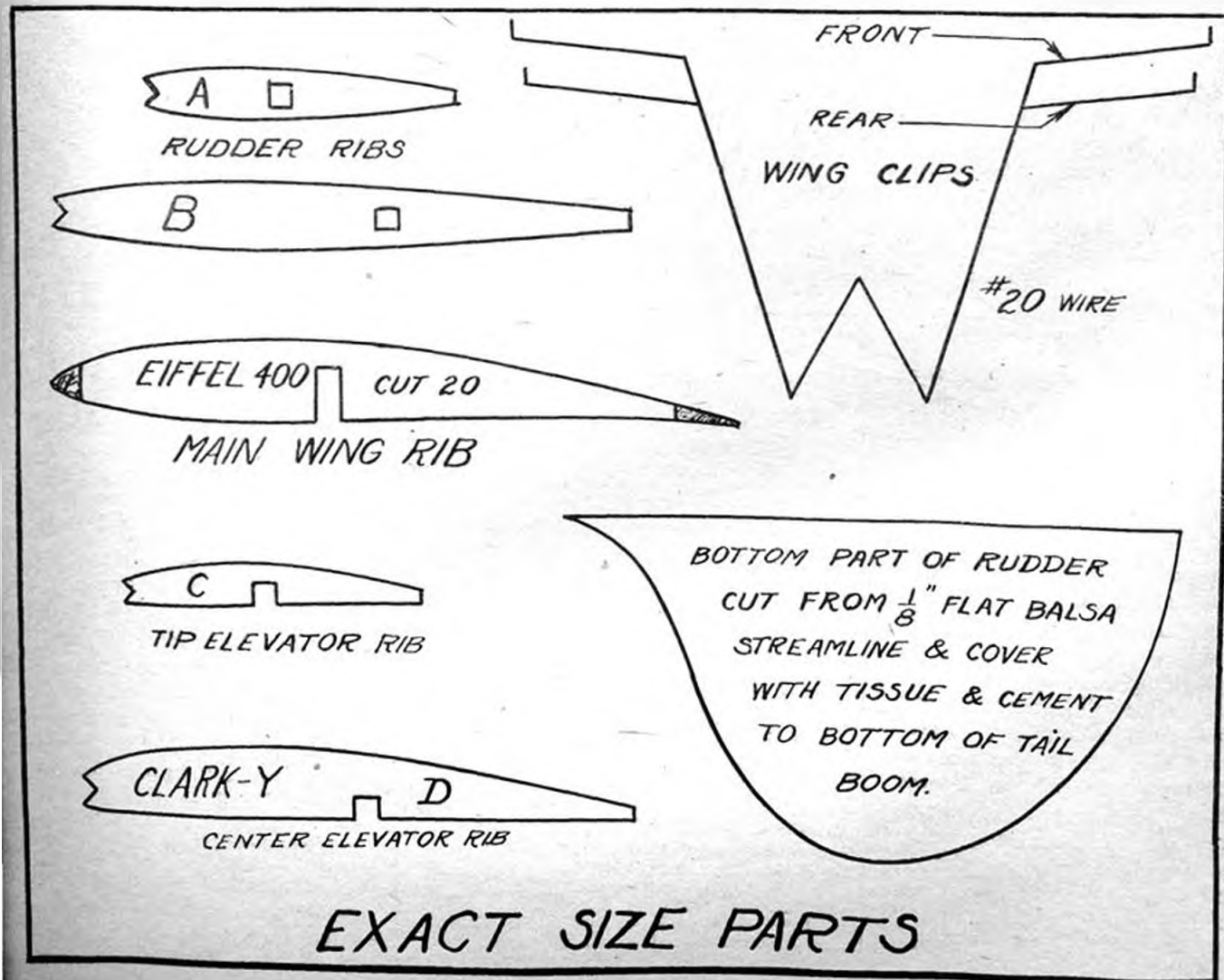

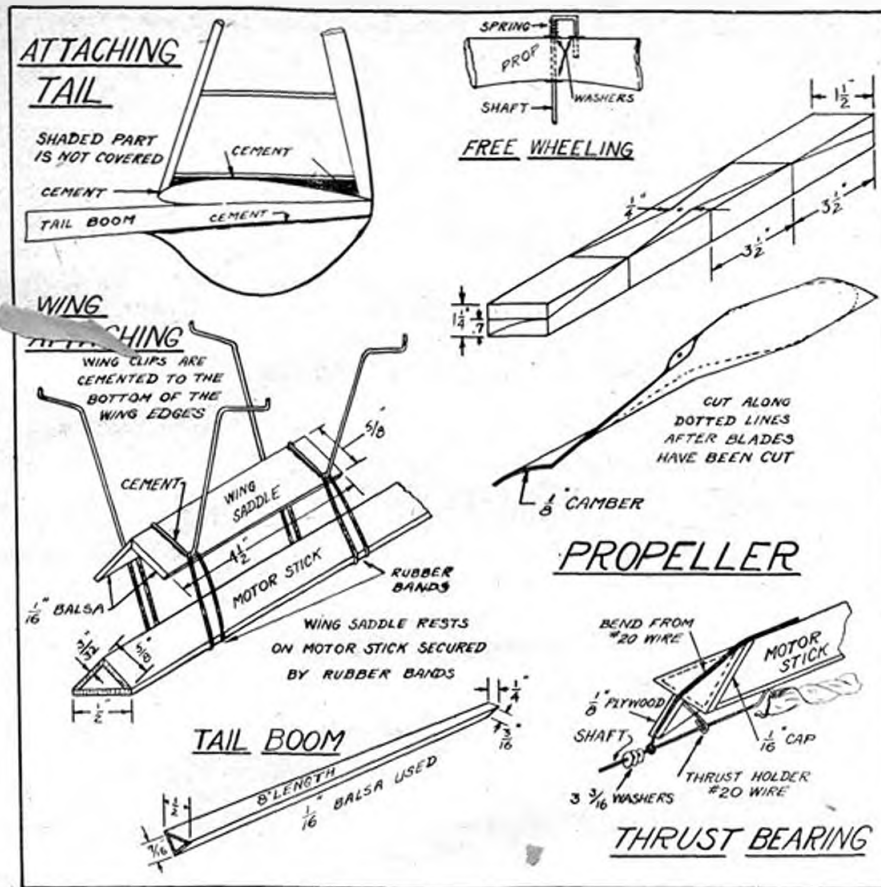

the wing will have to be broken and then cemented to raise the ends of the wings. Halfway out each side of the wing, the dihedral should be  $\frac{3}{4}$ ". Break the wing at this point and raise the tips until they are 5" above the center. Liberal coatings of cement will restore the wing's strength where it was necessary to break it.

### ATTACHING THE WING

The wing is mounted to the motor stick with a balsa saddle that rests atop the stick and is secured with rubber bands which pass underneath the stick. Two wing clips are bent from #20 wire. The front clip is  $\frac{1}{4}$ " higher than the rear one. The size of the clips gives the wing the correct angle of incidence. These clips are cemented and bound to the leading and trailing edges of the wing. The wing saddle consists of two pieces of  $\frac{1}{16} \times \frac{5}{8} \times 4\frac{1}{2}$ " balsa which are cemented edge to edge to form a "V" which fits snugly on top the motor stick. The wing clips are cemented rigidly to this saddle. The rubber bands are illustrated in the drawing.

### ELEVATOR AND RUDDER

on top and the flat part of the stick is on the bottom. Naturally, the edges of the boom will protrude where the joint is made with the motor stick. Don't cut these off. Fare any rough edges by filleting with pieces of balsa. These balsa pieces supply additional strength, in addition to maintaining the symmetrical shape of the stick. The boom is cemented at a slight upward angle. As is visible from the three-view drawing, the extreme rear top of the boom should be just about level with the top of the motor stick.

and sweepback, but there is the taper to consider. Elevator ribs C and D are shown exact size. The other three sizes of ribs are cut so they taper in length and thickness. Good practice is to assemble the elevator with only the center and two end ribs in position. Then fit in the other ribs, cutting them to the correct depth. By resting a straight edge across the top of the center and end ribs you can readily determine the depth of the intermediate ribs.

The same process can be followed with the rudder

where ribs A and B are shown exact size and the other ribs are fitted in. Part of the rudder is made from  $\frac{1}{8}$ " sheet balsa. Using the full-size pattern, cut this part and sand it to a streamline shape.

### COVERING

No special treatment is used in this operation. Banana oil is used to attach the tissue. The bottom sheet-balsa section of the rudder is covered with tissue. The stick is protected by one or two coats of banana oil, followed by a rubdown with sandpaper. The model is treated with light dope—using as many coats as necessary to give the protection and strength for all-weather flying.

### ATTACHING TAIL SURFACES

The elevator is mounted flat on the boom. It is set at a two-degree negative angle. If you've attached the (Turn to page 92.

### WING

The airfoil used is the Eiffel 400. 20 ribs of  $\frac{1}{16}$ " medium-hard balsa are used in the wing. The ribs are notched to take a  $\frac{1}{8} \times \frac{5}{16}$ " main spar. Considerable checking will have to be done throughout all stages of wing construction, to make sure you build the correct amount of dihedral and sweepback into the wing.

Building the wing over a full-size outline will insure correct rib spacing and sweepback. Sketch a full-size pattern on a piece of scrap wrapping paper. It need be only the simplest outline of a drawing. Build the wing flat on the workbench ignoring the dihedral until the wing has been entirely assembled.

Dihedral is put into the wing at three points. The center of

### MATERIAL REQUIRED

#### MOTOR STICK AND BOOM

- 2 pcs.  $\frac{3}{32} \times \frac{5}{8} \times 18$ "
- 1 pc.  $\frac{3}{32} \times \frac{1}{2} \times 18$ "
- 2 pcs.  $\frac{1}{16} \times \frac{1}{16} \times 8$ "
- 1 pc.  $\frac{1}{16} \times \frac{1}{2} \times 8$ "
- 1 scrap 3-ply wood  $\frac{1}{8}$ " thickness
- $\frac{1}{2}$  foot #20 wire

#### WING AND TAIL

- 1 trailing edge  $\frac{1}{8} \times \frac{3}{8} \times 28$ "
- 1 spar  $\frac{1}{8} \times \frac{1}{10} \times 32$ "
- 1 leading edge  $\frac{3}{16} \times \frac{5}{16} \times 32$ "
- 1 8" length of bamboo
- 2 feet #20 wire
- 2 pcs.  $\frac{1}{16} \times \frac{5}{8} \times 4\frac{1}{2}$ " balsa for wing saddle
- 1 leading edge  $\frac{1}{8} \times \frac{1}{8} \times 18$ "
- 1 trailing edge  $\frac{3}{32} \times \frac{1}{4} \times 18$ "
- 1 spar  $\frac{1}{8} \times \frac{1}{4} \times 19$ "
- 1 pc. sheet  $\frac{1}{8} \times 2 \times 3\frac{1}{2}$ "

#### ADDITIONAL MATERIAL

- 1 propeller block  $1\frac{1}{4} \times 1\frac{1}{2} \times 14$ "
- #20 wire shaft and "S" hook, freewheeling spring,
- washers, 30 feet  $\frac{1}{8}$ " flat brown rubber, cement, banana oil, and dope.

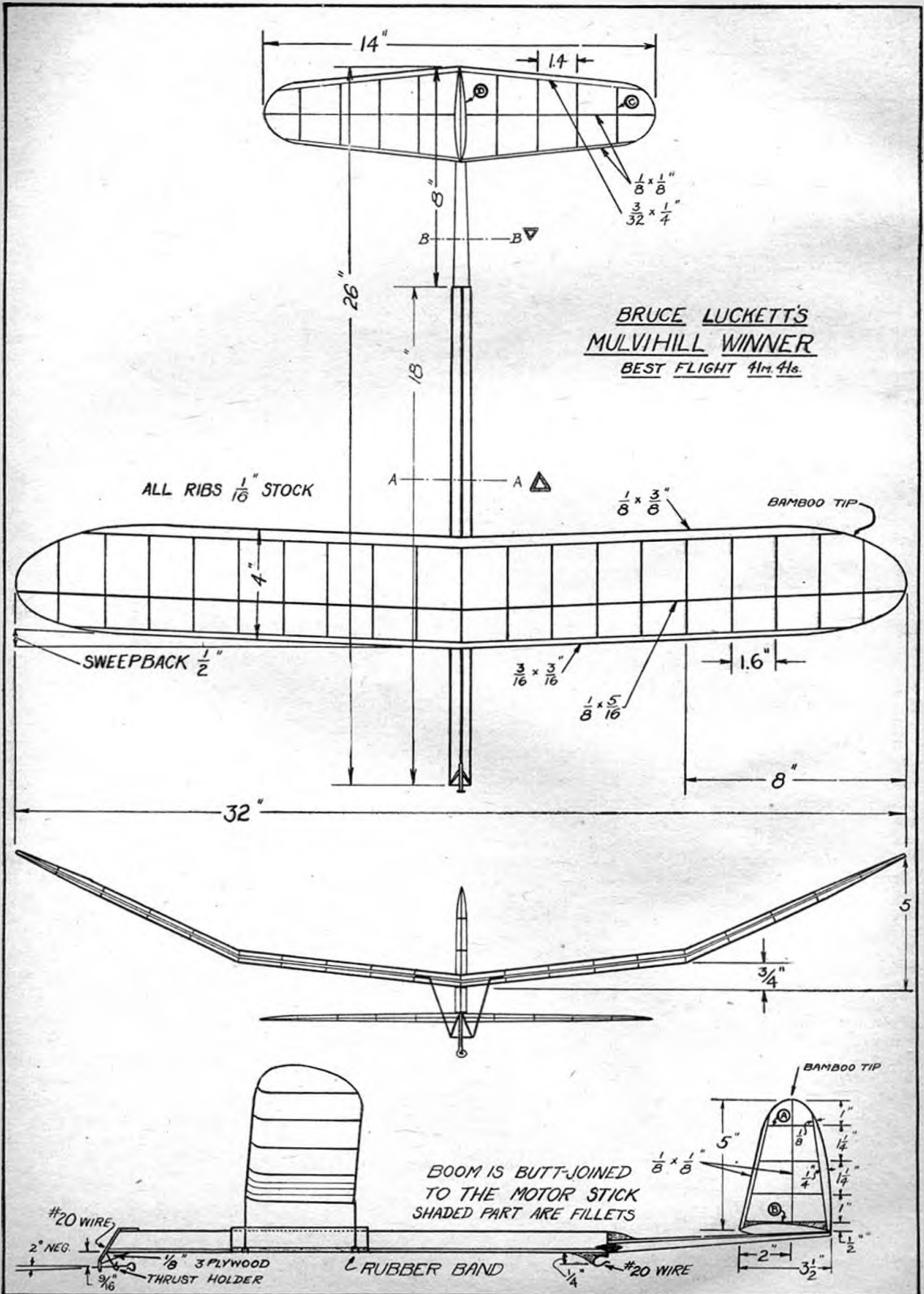

*Flight records  
and contestants  
in competitions.*

# Model Matters

*Club notes and  
news of model  
organizations.*

(In contest tabulations, results are to be read as minutes (to left of colon), seconds, and fractions.)

## San Diego Clubs

The Aviation Advancement Club of San Diego, California, is one of the most active of the West-coast aviation organizations. It has 25 members who are interested in all phases of flying. The club owns and flies a glider. Interest in gas-model flying runs high among club members. The Aviation Advancement Club has sponsored several meets. They've developed precision contests rather than duration. Entrants are judged by the appearance and attractiveness of their models; ability to make flights within a reasonable time after they've been called; and the take-off,



John Pond of San Francisco with his third gas model. Flights are made at Sunnyvale, California.

flight, and landing of their models. This type of contest has almost completely replaced duration events on the West coast. Practically every one agrees it is more interesting for the spectators and the entrants.

Recently the Aviation Advancement Club joined forces with the San Diego Gas Model Club in promoting gas-model activities. One feature of their contests, which seemed attractive, is charging admission to the flying field. A gas-model contest is well worth a small charge and it helps to finance the contest. And when the expense of the contest is met by model clubs, as in this case, an admission charge is a necessity. These gas-model contests are open to all model builders and every contest attracts a rousing list of modelers. That's not much of a surprise when you learn that the San Diego Gas Model Club itself has 47 members and about 30 gas jobs.

Modelers planning to enter future contests, or interested in joining forces with either of these two organizations, are invited to write either D. S. Halacy, Secretary of the A. A. C., 4937 Vista Place, San Diego, California; or to S. Phillips Andrews, Director of the San

Diego Gas Model Club, San Diego, California.

## Junior Aviation League

Old records fell by the wayside when Jordan Marsh-Boston Traveler Junior Aviation League members flew in their first monthly contest of the new year, Saturday, January 2nd, in the Irvington Street Armory, Boston, Mass.

Junior contestants took top honors as they set three new Boston model aeronautical marks. A senior flier established a new local record.

Every entrant in the Junior Aviation League meet turned in a performance beyond expectation, despite adverse flying conditions.

Winners in the glider class were:

- |                                      |           |
|--------------------------------------|-----------|
| 1. Hewitt Phillips, senior (class B) | 31.2 sec. |
| 2. Arthur Sampson, junior (class A)  | 30.6 sec. |
| 3. Wilbur Tyler, senior (class A)    | 30 sec.   |
| Gordon Cain, senior (class B)        | 30 sec.   |

Martin Phillips, 12, set the first record of the day, when he made a flight of 27.8 seconds with his Class B glider in the junior category.

Unusually lengthy flights were made in the tournament for flying scale models. Winners were:

- |                                      |           |
|--------------------------------------|-----------|
| 1. Arthur McLean (Rearwin Speedster) | 50 sec.   |
| 2. Jack Golden (Monocoupe)           | 42 sec.   |
| 3. Morris Sulkin (Monocoupe)         | 37.2 sec. |

In the fuselage rise-off-ground category, winners were:

- |                                     |        |
|-------------------------------------|--------|
| 1. Robert Shea, senior (class B)    | 5:46   |
| 2. Irving Sherman, junior (class C) | 5:03.4 |
| 3. Ralph Brown, junior (class B)    | 3:44   |

Another record was shattered when, in this fuselage rise-off-ground class, Morris Sulkin, a junior contestant, sent his Class C plane aloft for 3:39.

The longest flights of the day came in the stick-type hand-launched event. Those placing highest were:

- |                                      |        |
|--------------------------------------|--------|
| 1. Torrey Capo, senior (class C)     | 10:44  |
| 2. Hewitt Phillips, senior (class C) | 8:52.2 |
| 3. Wilbur Tyler, senior (class B)    | 6:38   |

Helicopter winners were:

- |                           |        |
|---------------------------|--------|
| 1. Douglas Hannon, senior | 1:20.2 |
| 2. George Elberfeld       | :45    |

Hannon's flight constituted a new Boston record.

Ornithopters provided much amusement. Winners were as follows:

- |                                |       |
|--------------------------------|-------|
| 1. Ralph Brown, junior         | :07.6 |
| 2. Edmund Whitten, Jr., senior | :07.2 |
| 3. Hewitt Phillips, senior     | :06   |

Both Brown and Whitten made new records for their respective classes.

A highlight of the day's flying was a model autogiro, constructed and flown by Captain Willis C. Brown, adviser to the Junior Aviation League. Captain

Brown succeeded in making lengthy flights with his miniature autogiro. He promises an assault on existing records for this category soon.

## New Zealand Tragedy

We've a letter from Vernon Gray, Moffett winner, who lives in New Zealand. Fine summer weather, suitable for model flying, has moved into New Zealand. But Vernon wasn't on hand to greet it as an outdoor enthusiast should be. He was in bed recovering from a crackup. About the end of last year he was badly injured chasing one of his roaming fuselage models. He was beginning to recover when he wrote us, so by this time he's probably up and flying again. We certainly hope so. He planned to do considerable model building while in bed, so he could concentrate on flying when he's on his feet again. New Wakefield and Moffett entries are a part of his building program.

We're sure sorry Vernon had tough luck, but we can't think of a more hon-



Flying scale Grainville model constructed by a member of the Model Aero Engineers of Hartford.

orable way of being injured than in chasing a model airplane. We've sprained ankles, been chased by bulls, and have gotten ivy poison while chasing models, but Vernon outdoes us. We sort of feel ashamed.

## Hangar 13

Hangar 13 is the name of a model club in Beloit, Wisconsin. It meets in the Y. M. C. A. every week. The club charges an initiation fee of 25c, and 10c dues every meeting. In return the 44 members of the club get practically all the material to build models, except the motors for gas models. Also, the 500 plans and blue prints which have been collected by the club are available to the members. Prospective club members must demonstrate definite interest in the club for a period of 1 year before

they are given membership cards. This eliminates those with only a passing interest in modeling and insures a 100-per-cent active membership.

The yearly financial report of the club indicates that it is sound, and these funds insure the continuance of activities from year to year. The fact that the club has been active since 1926 speaks well for this method of organization.

Gas modeling is one of the chief interests of this club. The photo which is reproduced here shows a model built by the club adviser, Conrad Hansen, Jr. It's the design of Irwin G. Ohlsson of Los Angeles, California. Dural outlines have been used on the tail and wing. Dural is also used as a motor mount. It makes an extremely rugged and lasting type of construction. Winter flights in below-freezing weather, being lost for several days, and a variety of other hard



This Ohlsson-designed gas model is the product of Conrad Hansen, Jr., of Beloit, Wisconsin.

knocks have not dented it. The model's climb is steep, and a well-streamlined engine gives it a speed of about 35 miles per hour.

Hangar 13 is lucky to have Hansen as director. He's an active organizer and a skilled modeler—a rare combination. His work has probably helped many a beginner down the rough road of modeling. And we suggest that builders in the vicinity of Beloit take advantage of his leadership. Address your letters to Conrad Hansen, Jr., Y. M. C. A., Beloit, Wisconsin.

### Hartford Model Club

The latest roll call of the Model Aero Engineers of Hartford revealed an active membership of 85 in Hartford alone. The high schools of East Hartford, Wethersfield, and Waterbury are organizing clubs under the Model Aero Engineers guidance.

The model photo is of the Grainville biplane, which not only appears well but flies consistently.

### Knight Club Of Brooklyn

The group of models pictured is a sample of the handiwork of the Knight Club, an active organization of Brooklyn, N. Y., a club also proficient in the building and flying of gas models.

### Chicago Aeronauts

The Chicago Aeronauts held a contest for helicopters recently in a 30-foot ceil-

ing building, and the records turned in were remarkable for this type of model. The winners were:

Junior: Alex Nekimken	2:07
Senior: Dean Decker	1:49
Open: Carl Goldberg	2:46

If Carl Goldberg tackles helicopters seriously, we can expect this record to show a substantial increase in the near future. Goldberg has been at the top of the list of indoor builders almost as long as we can remember. It should be interesting to trace his progress with helicopters.

### Gas Model And Annual Soaring Contests

Early in July the 8th Annual National Soaring Contest will be held. The scene of this nationally popular meet is to be Elmira, New York, an ideal location for soaring flights.

An integral part of the meet will be the three-day Eastern States' Gas Model Contest, full details for which will be contained in next month's contest calendar.

In the rolling hills of this section some of the world's finest soaring flights have been made. During last year's competition one entry climbed to 6,500 feet, an altitude gained purely by the adroit use of rising air currents. Sailplanes frequently travel a hundred miles or more, using fickle thermals or rising currents to maintain altitude.

Since the Elmira district is the headquarters for all those interested in the various phases of gliding, it is in keeping to briefly describe the facilities located at Harris Hill, the jumping-off spot for the competitors.

A development program expending over \$120,000 is providing the luxurious administration building, pilots' cabins and a glider hangar. A road 3¼ miles long is being paved to the hilltop. There a 200-foot runway 100 feet wide is in preparation for the forthcoming meet.

Should you be fortunate enough to be in attendance at this coming summer's contest, you will be guaranteed a busy visit.

Giant sailplanes, whose birdlike wings span approximately 60 feet, rise to dizzy heights in lazy circles, or occasionally accelerate to the uncanny gliding speed of 70 m.p.h. without sacrificing altitude loss of more than 3 feet per second.

To successfully soar it is necessary to delicately nurse the sailplane from the weakening top of one thermal down to the base of another, which, of course, must be sought for.

Final rewards are made on a point system, which allots a preponderance of points to those accomplishing the most difficult feat.

Usually the easiest attempt is for distance; for maximum altitude a greater number of points is given, but the great-

est point award is for a flight to an assigned point and return.

Following are notable soaring records: Duration with return to launching point, 36 hrs. 35 min.; distance 313,293 miles; altitude above starting point, 14,189.59 ft.

It is interesting to note that the Germans who originally developed this sport hold all the above-mentioned international records.

### Jacksonville Model Club

Starting the third year's activity the Jacksonville Club will hold their spring contest on Sunday, April 11th.

Since this club holds a charter in the Junior N. A. A., this contest, adhering to precedent, will be run under the sanction of that body. Accordingly, all entries must be designed to N. A. A. specifications and flown under its rules.

The following are the events:

Glider Hand Launched.....	Classes B, C, D.
Glders Tow Launched.....	Classes C, D, E.
Stick Models.....	Classes C, D.
Fuselage Models.....	Classes C, D, E.
Gas Models.....	

In addition to the above regular events, others of special interest are to be included as follows:

- Exhibition Scale
- Flying Scale
- Racing Models

Plans are already on foot for a similar contest during the summer. Picked



Group of models built by members of the Knight Club of Brooklyn, New York.

members are to represent the Jacksonville Club at the Nationals.

The director of this active club is William L. Timpone and the secretary, Milton Myers. Headquarters are located at 2048 Roselle Street, Jacksonville, Florida.

### Utica Gas Model Club

The gas-model builders of Utica have recently formed a gas-job club. The club—The Utica Gas Job Club—at present consists of fifteen members. The following members are the officers:

President—Ray Darling
Vice President—Tony Bally
Secretary—Bob Hamfeldt

Members plan to attend several contests this summer and are also going to sponsor one of their own. Any gas-job builders in the vicinity who wish to join the club are cordially invited.

For information, address Bob Hamfeldt, 648 James Street, Utica, New York.





The completed model with propellers removed illustrates the color scheme described.

**S**INCE the data on this ship has been given on other pages of this issue, let us start the model.

Read the directions and study the drawings carefully. You will note that the model is a  $\frac{1}{64}$ " sheet-covered, all-balsa type and that the main frames are of the simple, rectangular type with the formers added. Provision has been made to get better performance from the model by the use of extension nosings that permit the use of longer propellers, if desired. The tail surfaces are removable for rubber installation, and change from flying to scale surfaces.

### WING

Where wider sheets of the  $\frac{1}{64}$ " sheet are required, butt cement the 2" sheets together to the appropriate width. From such widths cut four oversize wing-panel patterns and two center section-panel patterns  $\frac{1}{8}$ " oversize in chord.

After the ribs have been cut out, make a pair of slotted main spars for the wings tapered to the last rib and wide as the wing is thick, also one center-section spar. The slotted main spars make possible the assembly of the wing panel parts without additional drawing.

The assembling should be done on a soft, smooth board. Taking one panel as an example, lay one of the wing-panel patterns on the board and assemble all the parts on it, using the trailing edge as a guide line. Slant Rib 1 for dihedral. Use plenty of pins to hold the parts in place and then cement all joints. When dry, "toenail" pins on a slant through the outside of Rib 1 and at the tip, then remove all of the other pins.

Flow cement across the tops of all ribs but the tip, and on the trailing edge and leading edge. Do the cementing quickly. Starting at the trailing edge, lay the top cover on. Pushing in pins where needed, smooth over to the leading edge, using still more pins. Make the two other panels and cement them together with 1" or more dihedral angle at the tips. Cement the tip edges together. Several of the scrap balsa clamps as shown on Drawing 3 will hold the edges together. Cut out the ailerons by holding the wing to the light and cutting between the spars. Reattach them with soft wire hinges.

### CABIN AND BIFUSELAGES

Make 2 cabin side frames and 4 bifuselage side frames from the side views, then space them apart according to the top views, using  $\frac{1}{16}$ " sq. throughout. To these frames, cement the formers in their proper positions, i. e.: C1T goes on top of



The finished parts shown before final assembly shows the simplicity of design.

# The FOKKER G-1

*A Double Fuselage*

*Flying Scale Model*

by Alan

D.

Booton



Here the unpainted G-1 is shown inverted. Note the installation of the tail wheel and landing gear.

the 1st cabin station, C1S goes on each side of the 1st cabin station, and C1B goes on the bottom of the 1st cabin station, etc.

When the B3 stations on the bifuselage are reached, they are continued by the longeron former method.

The rounded nose of the cabin and the forms behind the cowls are carved and hollowed as indicated. The cowls are made simply by wrapping the covers ( $\frac{1}{32}$ " sheet) over the prepared disks. Rubber bands hold the covers until the cement dries. Conventional nose plugs are used. Leave the carved parts and cowl off until the model has been covered.

### RUDDERS AND STABILIZER

Taking one rudder for example, it is  $\frac{1}{64}$ " sheet-covered and has no frame. The  $\frac{1}{16}$ " streamline ribs are cemented to the  $\frac{1}{16}$ " leading edge and left to dry. Cut 4 rudder patterns to cover above the bottom rib. Cement the edges of the ribs and around the edge of one pattern and cover the ribs as making a sandwich. Fasten the edges of the sheet together with the scrap balsa clamps mentioned above. Cement formers 6 and 7 in place on the lower rib. Former 6 must have the rear hook and end plug mounted. Cover the remainder of the rudder longitudinally.

The stabilizer frame is made on a completed drawing and cemented to the rudders according to the position on the side-view drawing of the rudder. Leave the stabilizer covering until later.

### REMAINDER OF COVERING

Slip the cabin frame to the center of the wing and pin in place, then cement all points of contact securely. Slip the bifuselage frames on the wing and plug in the tail assembly. The center lines of the bifuselage frames,

when parallel should match the position of the top-view drawing, but  $\frac{1}{16}$ " variation will not differ. Pin the bifuselage frames so the stabilizer sights in line with the center section and then cement all points of contact. Cut away portions of the cover and spars to allow motor clearance under the wing. Cover stabilizer with  $\frac{1}{64}$ " sheet. (Turn to page 87)

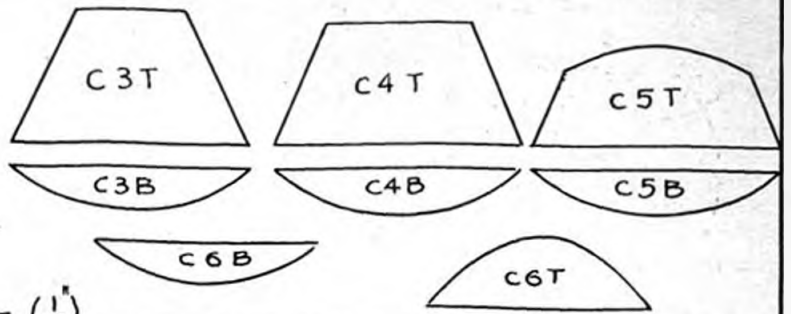
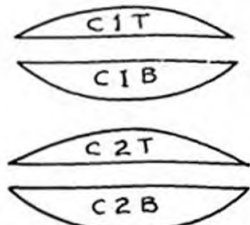
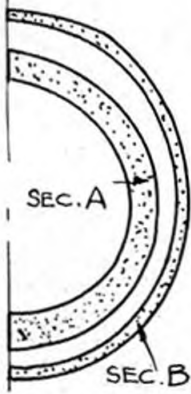

...ONE EACH OF ABOVE (1/16")

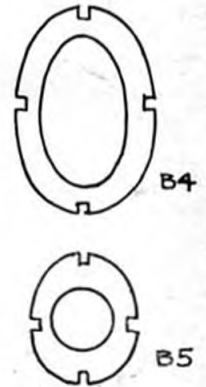
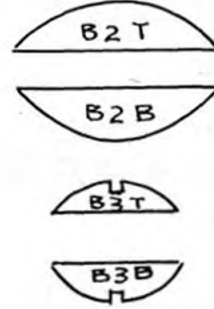
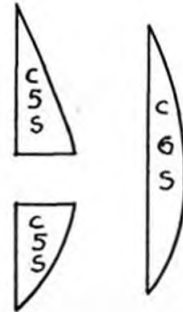
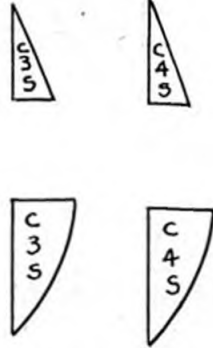
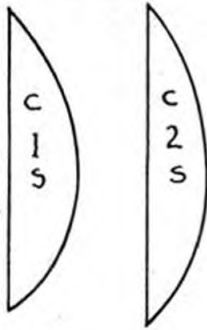

TWO EACH OF ABOVE (1/16")

1/16" PLYWOOD

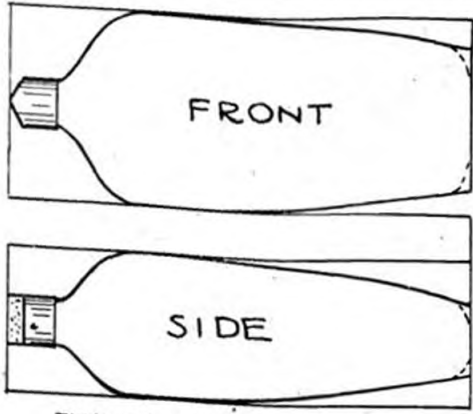

FLYING BLADES BLANK



MAKE 2 EA. (1/16")



MAKE 4 EACH (1/16")

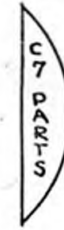

MAKE 8 (1/16")

SECTIONS & FORMERS

LANDING GEAR

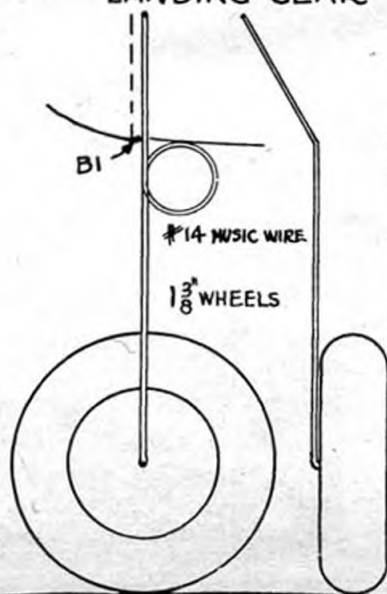

CARVE 3 LEFT AND 3 RIGHT FROM 3/4" X 1" X 2 3/8" BLOCKS.

Longer and higher flights may be obtained by using longer nosings, which will enable the use longer, more efficient propellers, and longer rubber motors.

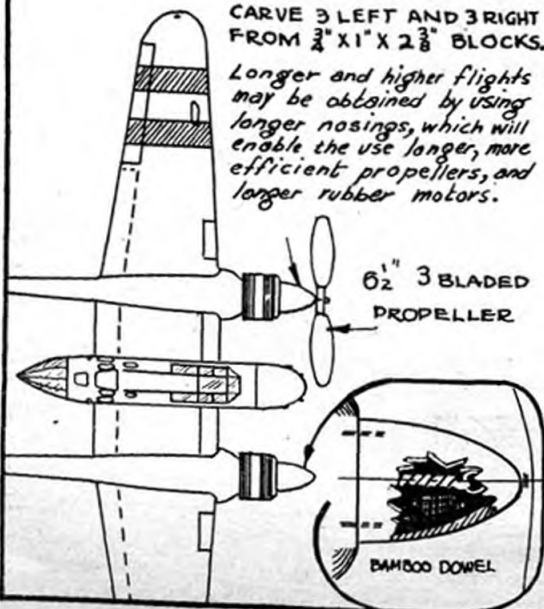

**BILL BARNES**  
**AIR TRAILS**  
FLYING SCALE MODEL  
of the  
**FOKKER G.1.**  
BIMOTOR BIFUSELAGE:  
ATTACK PLANE,  
& LIGHT BOMBER.  
SCALED TO 1/2" = 1'-0"

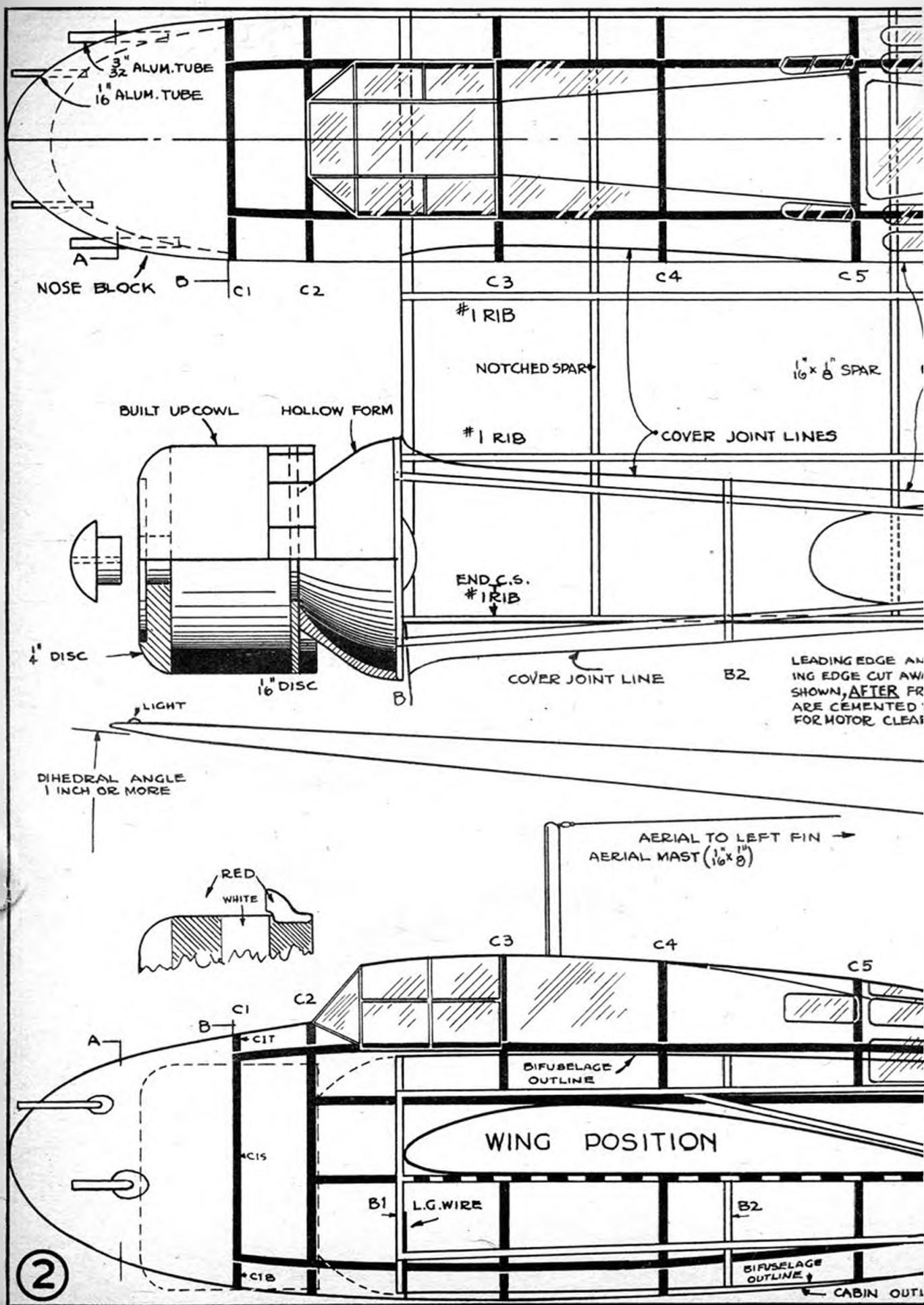

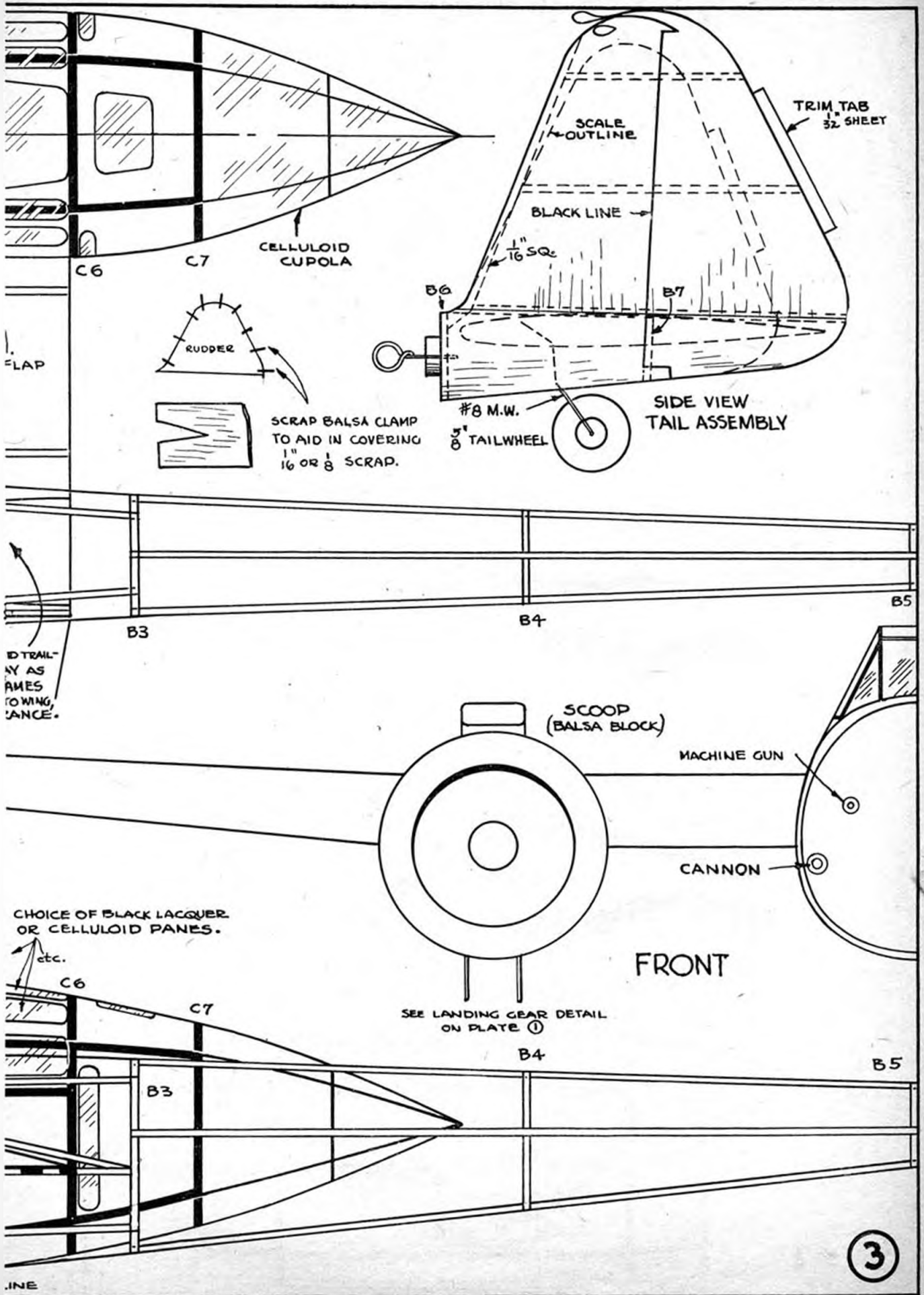

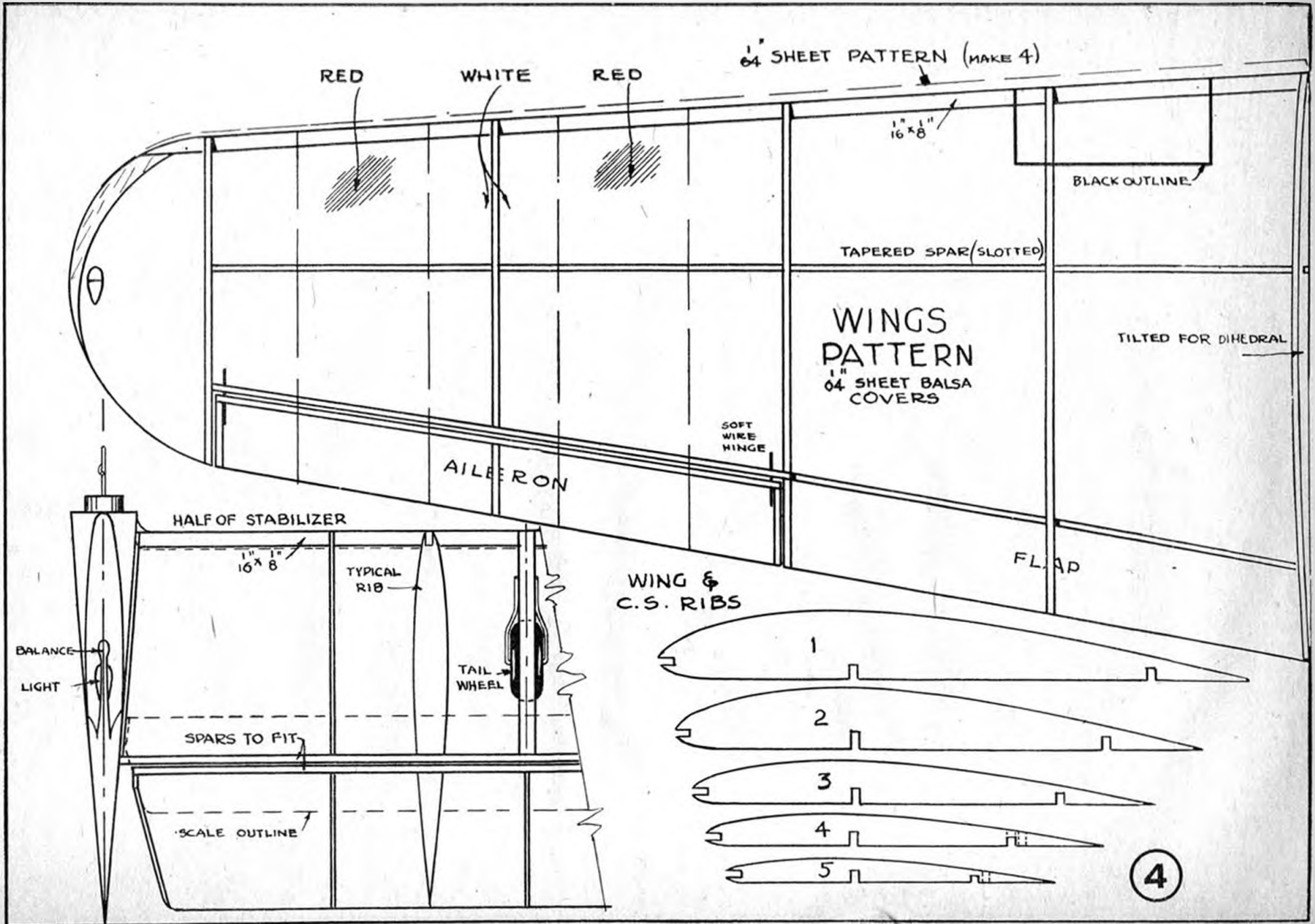

*Have you a question on model building or flying that bothers you? Bring us your problem and*



*we'll answer it in the interest of readers everywhere. Replies by mail require return postage.*

#### DRAWING CURVES

*Question: How do you draw the long outline curves on a side view of a fuselage model? G. M., Fremont, Ohio.*

*Answer:* In the drafting room, long curves are made with curved pieces of celluloid known as "ship" curves, or with splines, which are flexible curves that retain any shape to which they are bent. But this equipment is usually too expensive for the modeler draftsman. You can make an efficient substitute spline for a few cents. Obtain a three- or four-foot length of  $\frac{1}{8} \times \frac{1}{4}$ " straight, hard balsa. Insert pins into the balsa piece every few inches. When drawing a curve, bend the balsa to shape and secure it by pushing the pins into the drawing board. Before drawing in the shape, change the balsa spline until you're convinced it's the curve you want and then draw in the line. This will spare you needless erasing and will enable you to visualize the shape of the finished fuselage better than a line on the drawing paper.

#### TIRE TREADING

*Question: What is the bandtex mentioned by Alan Booton in his article on gas-model balloon tires in the October, 1936, issue? M. D., Brooklyn, N. Y.*

*Answer:* Bandtex is available in drug stores. Its chief use is for dressing finger cuts. Merely wrap a piece of bandtex around your finger and press the ends together. Bandtex will not stick to anything other than itself, unless, of course, cement is used. It resembles adhesive tape in many respects. Booton used it for treading on his gas-model tires. Here it was necessary to use rubber cement for attaching. Possibly you'll discover that your drug store has the equivalent of bandtex under a different trade name. It's a convenient material to keep on hand in the model shop.

#### RADIO-CONTROLLED MODEL RULES

*Question: Will you please give me the contest rules for the radio-controlled gas-model contest which will be conducted this summer? M. D., Los Angeles, Calif.*

*Answer:* The only requirement in this contest is that you conclusively demonstrate to the judges that you are capable of controlling your gas model from the ground. If there are a number of entries, naturally the model performing the most complete list of maneuvers will win. So little has been demonstrated in the way of radio-controlled gas models that definite rules are impossible. The size of the model will not be limited, since a large model will probably be necessary to carry the additional weight of the radio equipment. Entrants in this contest will be given a free hand as far as the design of the model is concerned, and they can spend all of their time on the radio control.

The contest is tentatively set for Detroit. It will be

held as part of the National Contest which is scheduled for late June or early July. How the two-hundred-dollar prize money offered by the A. C. Spark Plug Co. will be distributed among the winners is not known. But you can be assured that the winner will get a substantial share, that will go far to repay him for the expense of building a radio-controlled model.

#### PROPELLER PITCH

*Question: What is meant when the pitch of a propeller is said to be 1.4 times the diameter? P. H., Punxsutawney, Penna.*

*Answer:* Propeller pitch is a phase of design that troubles most modelers. The question has been asked before. But it's important enough to discuss again. Pitch refers to the angle of the propeller blades. A high-pitch propeller is one in which the blades are at a steep angle. That is, as a high-pitch propeller revolves, the blades "bite off" large chunks of air and tend to move forward much more rapidly than a low-pitch propeller, in which the blades are at a flatter angle.

The pitch of a propeller is determined by the size of the block from which it is cut. For example, a propeller from a block with 2" width and depth would have a much higher blade angle than if the depth was reduced to half. The most efficient propeller is one in which the blade angle decreases toward the tip. That is why propeller blocks are tapered before the blade is cut. The usual rule is to make the depth of the block at the tips about half the depth at the center of the blade. A typical method of block shaping is illustrated in the plans for Luckett's winning Mulvihill model in this issue.

The pitch of the propeller can be found from the formula based on the dimensions of the block. Pitch equals  $\frac{\text{Depth} \times \text{diam} \times 3.14}{\text{Width}}$ . Finding the pitch of Luckett's model we have  $\frac{.7 \times 14 \times 3.14}{1.5}$ . Performing the arithmetic, the pitch is 20.6 inches.

And now for the original question of what is meant when the pitch of a propeller is said to be 1.4 times the diameter? This ratio between the pitch and the diameter is merely a convenient way of identifying the types of propellers. This value is obtained by dividing the pitch by the diameter. Referring again to Luckett's ship, the pitch-diameter ratio would be about 1.5, which is an average value for outdoor rubber models. For gas models the propeller pitch will be only one half the diameter.

A high-pitch propeller is out of place on a gas engine, since the steep blade angle will offer too much resistance to rapid turning and the gas engine will not be able to speed up to its designed r.p.m. The exact opposite effect is wanted on indoor models. That is, for maximum duration, with little power, a slow-turning propeller is necessary. The pitch is likely to be about twice the diameter.

# Double-surfaced Indoor Tractor

*A regal flight-king for the indoor enthusiast.*

by Lawrence N. Smithline

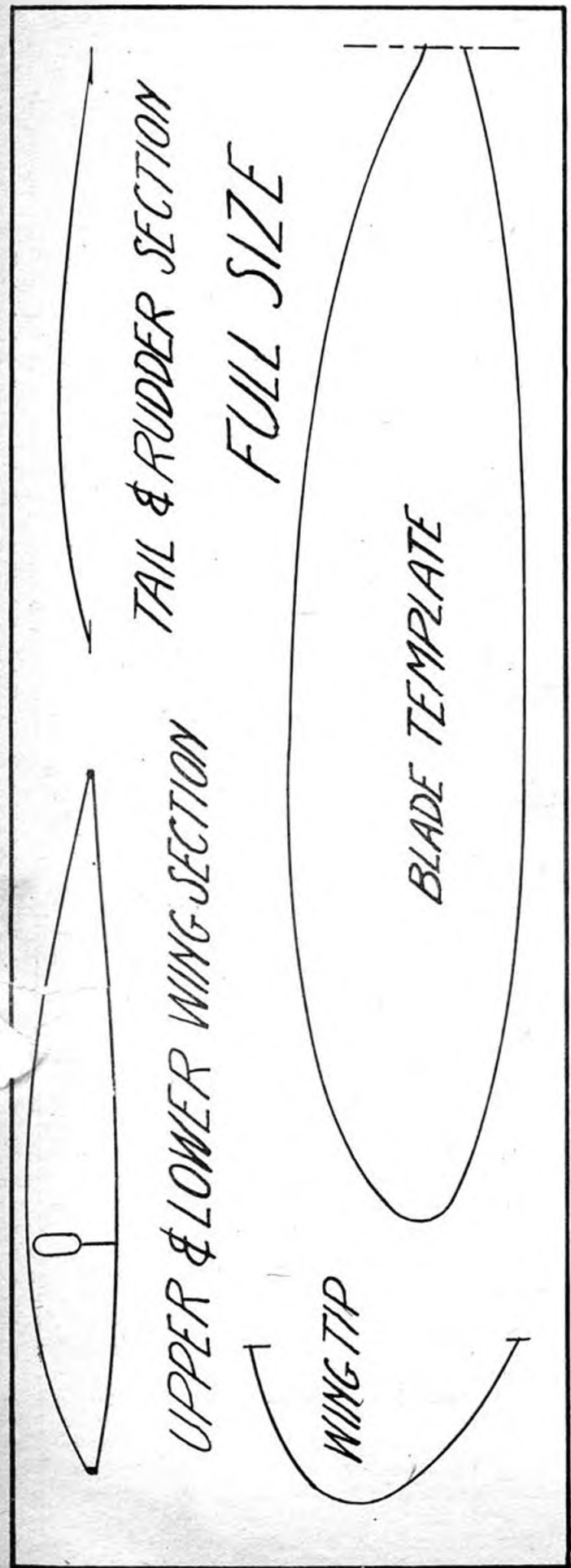
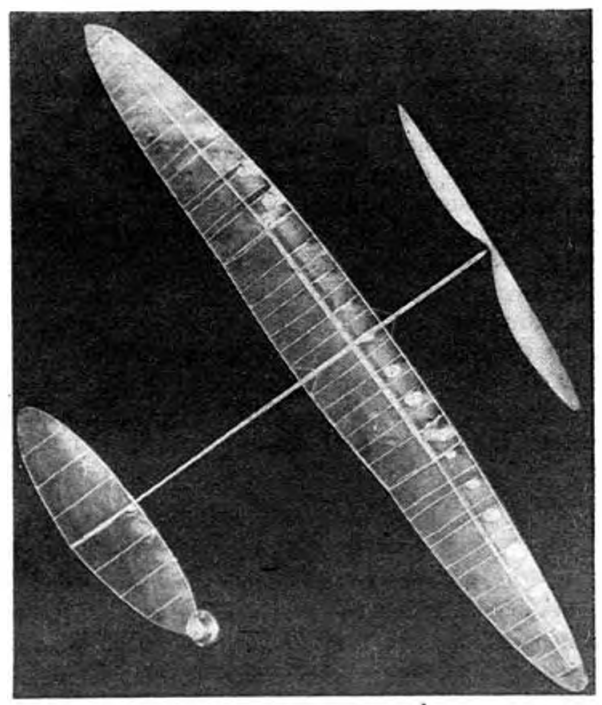

THREE YEARS AGO a small clique of indoor builders, the Aeronuts of New York, came to the conclusion that double-surfaced ships would be the ultimate design. One of this group built 3 double-surfaced wings. The first was an ordinary wing, except that flat ribs were put in for a lower surface. Great difficulty was experienced in flying this model. Apparently covering the wing on the bottom had a tendency to make the wing floppy, in spite of the fact that as a single surface wing it was all right.

The second wing was built on the same principle, except that the spars were made hollow—to prevent floppiness and still keep the weight down. This wing, although it still showed a tendency toward floppiness was satisfactory. However, before any extensive tests could be made, an indoor glider took out most of the ribs and covering.

The third wing was a radical departure from either of the preceding wings. It was a monospar type, the spar of which ran along the one third chord point. This wing, on a test flight, collapsed, and with it went the last of double-surface experimentation for 3 years.

In presenting this design it is hoped that more fellows will experiment with this type, so that its true value might be determined. The design being presented is perhaps not the ultimate; however, it eliminates the bad features found in the (Turn to page 94)

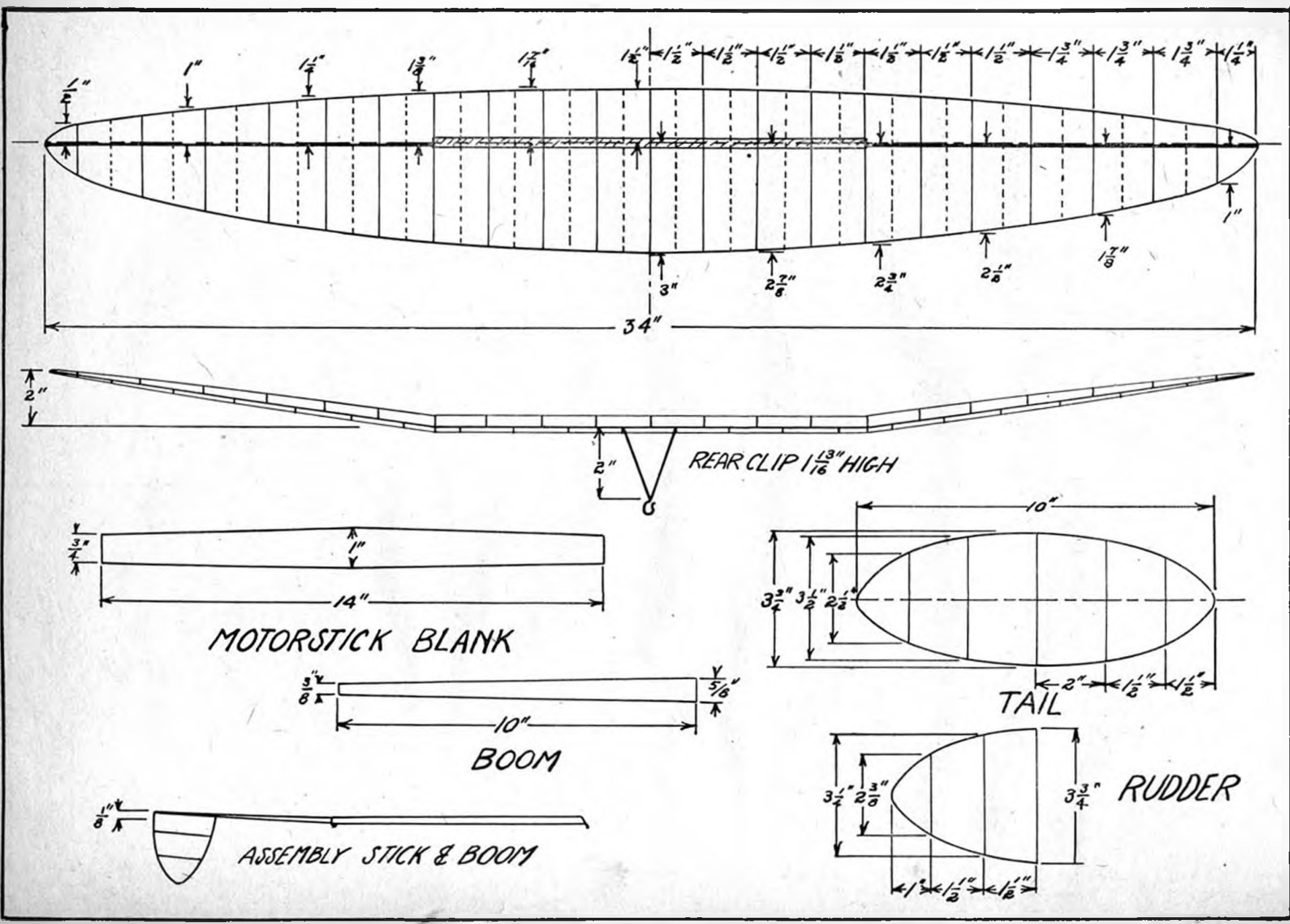



# The Discussion CORNER

*The model art progresses through exchange of ideas. The Discussion Corner is a monthly sounding board for your opinions. This month readers discuss color visibility. For May the subject is adjustable pitch propellers on outdoor models. Other topics are listed below. Think about them, then write your opinion in 150 words or less and send it to The Discussion Corner. One dollar is paid for each answer printed.*

**F**ROM past experience in flying all-weather models, I find that the background against which they are flown is either blue and white, as on a bright, sunny day, or gray and drab. Red coloring shows up splendidly against a bright background, and the yellow is plainly visible against dark clouds. The best coloring scheme is a yellow tail surface and fuselage with red wings. A silver or black propeller will reflect the sunlight on bright days. As these colors predominate on contest models, they must be the logical choice.—JOHN VOPAT, JR., Garfield Heights, Ohio.

The upper surface of a ship should be colored some light hue, such as yellow, which is a definite contrast to the landscape and facilitates finding the model after it has landed. The bottom should be covered with dark, opaque tissue. Dark so that it can be seen against a light sky when overhead. A high polish on the propeller is important. Many a contest is won because the ship is timed for a few extra seconds, visible only by the joint of the sun on the spinning propeller.—CURTIS JANKE, Sheboygan, Wisconsin.

The best color scheme for an all-weather outdoor model is either solid red, or red combined with white or yellow. A good scheme to use is a red wing and stabilizers and a white or yellow fuselage and a yellow rudder. Another good idea is to make the propeller glossy. The flash of the propeller in the sun will keep the model in sight longer than any other color scheme on the other parts of the model.—RYAN McMURTRY, Jackson, Mississippi.

Colors for outdoor models should be: yellow wings with a dark-blue fuselage and yellow tail surfaces; orange wings and tail with a black fuselage. Brown and black should never be used together, because they are the color of the ground and do not show up well against foliage. Light blue is taboo because it is the color of the sky. White has the disadvantage of being the same color as the clouds.—ROGER L. LASKEY, Wakpeton, North Dakota.

Black and white is a perfect combination. At night white stands out perfectly against the dark sky. In the daytime black is correspondingly clearly visible.—MAX BURNSTEIN, Brooklyn, New York.

One of the best color schemes is red in combination with yellow. It is effective and attractive. For utility, the fuselage and stabilizer should be dark red, and the wings and rudder a bright yellow. The red surfaces will remain in sight longest against a light sky. The yellow wings can be seen against dark clouds, and in combination with the yellow rudder can be located when in trees or on the ground. We fly in mountainous terrain, and frequently have models in flight which are below the crest of a distant mountain, or even below us in a valley. The red-and-yellow combination proves best for visibility.

The propeller should be of natural-wood color but highly polished, so it will glitter in the sunlight when high in the sky.—EARL STAHL, Johnstown, Pennsylvania.

I find that black and red are best—red wings and a black

fuselage. The black body will show up against a light background, such as fog or clouds. The red will show up brightly against the blue sky and will also accent the effect of the black on a light background.

On a large model I favor the use of black on the wings and a red fuselage. This will make a larger patch of contrasting color in the sky; while on a smaller model I favor a reversal of the above combination. A small model usually flies lower than a large model, therefore a red wing will be more easily visible against a background of foliage.—DOUGLAS C. ATKINS, Washington, D. C.

(Turn to page 96)

COMING UP are these topics:

For June—*What trouble do you experience with gas models? Is it in construction or motor operation? Has increased expense kept you from building gas models?* Answers must reach us by March 15th.

For July—*Which type do you prefer for best results in the original flying model: parasol, wing flush with fuselage top, or low wing?* Answers must reach us by April 15th.

## *This Month's Topic*

What color combination is best on an all-weather outdoor model, for greatest visibility?

# Builder's Guide

Enlargement Of Plans  
by William Winter

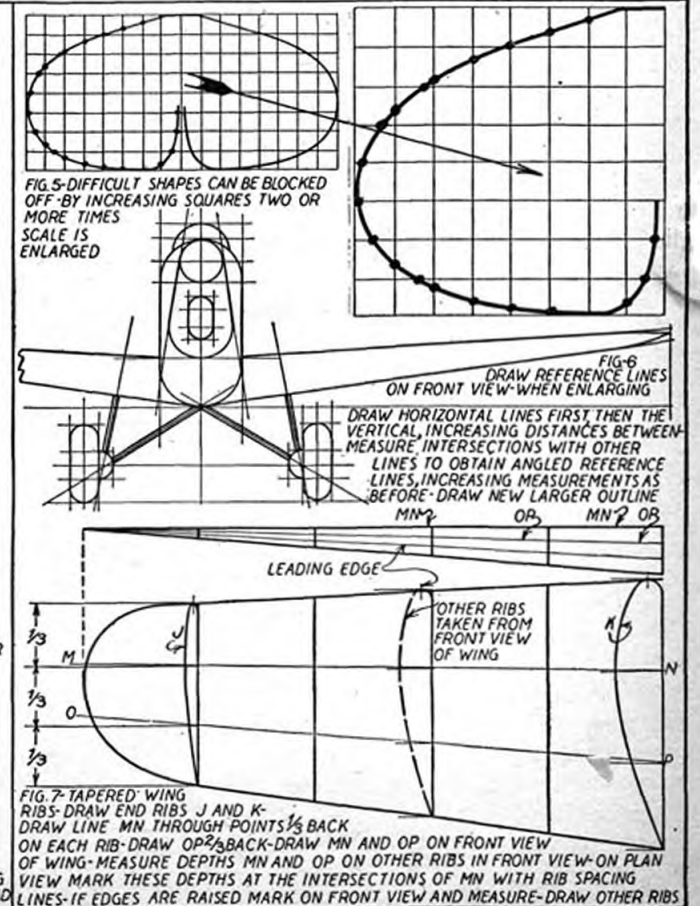
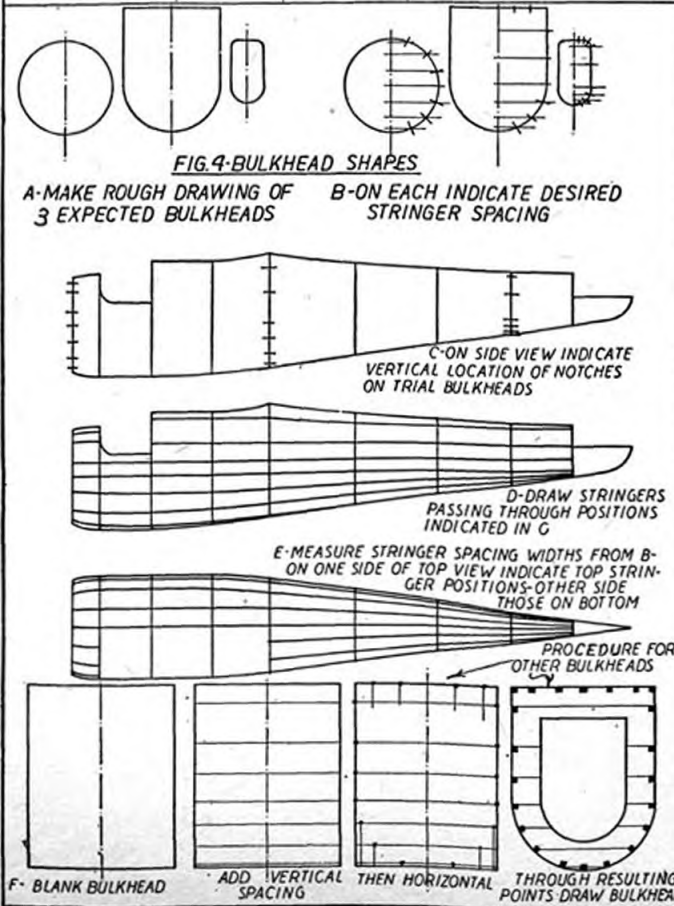
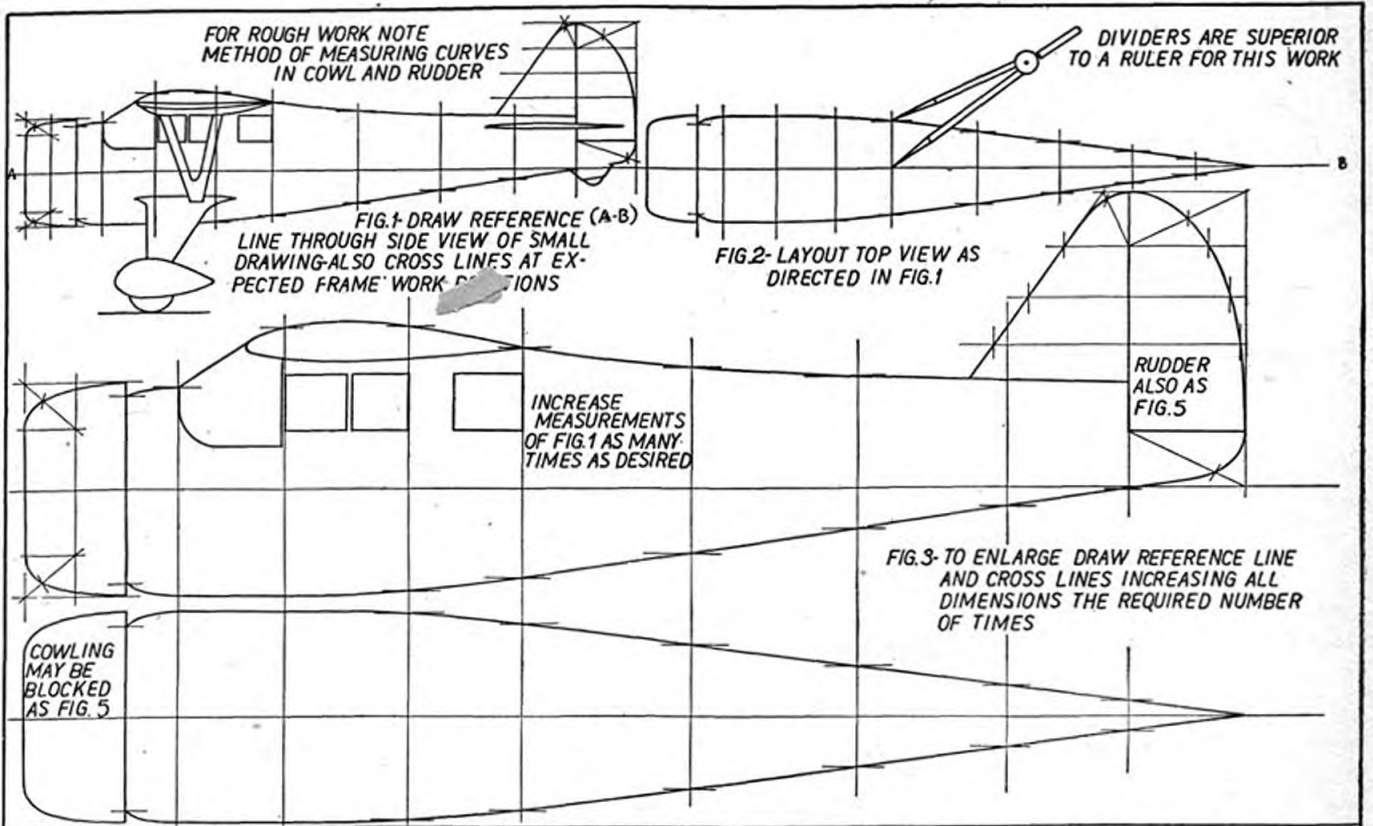

# Miles Mohawk

*Colonel Lindbergh's new half-British half-American high-speed sport plane.*

by William Winter

THE Miles *Mohawk*, Colonel Lindbergh's new, high-speed, low wing was designed and built by Phillips and Powis under his supervision. The *Mohawk* is similar to the standard Miles two-seater, except for a number of modifications not discernible to the unpracticed eye, chief of which is the use of the American Menasco engine.

Since the manufacture is essentially British and the engine American, the plane has been dubbed "Colonel Lindbergh's half-English, half-American plane."

## DIRECTIONS FOR CONSTRUCTING THE MODEL

All material dimensions are given at the close of the directions. Trim a block of soft balsa to the required outside dimensions of the fuselage. On the side of the block draw the profile of the fuselage and shave away the excess wood. On the top of the block indicate the top outlines and again cut away the surplus balsa. Shape the semifinished block to the desired cross sections, checking the work with the templates supplied for the purpose. These templates may be pasted on stiff paper for accuracy.

The cabin portion may be either cut out and then built up or may merely be painted white and outlined with black after the job is finished. Before sanding the fuselage to a satin finish drill the holes to receive the wing attachment dowels.

Cut the tail surfaces to the required shapes from  $\frac{3}{32}$ " soft-sheet balsa and trim them to the necessary streamlined cross section. Sand the finished tail units and cement them in position on the fuselage, noting that the one-piece stabilizer is to be filleted in later.

Cut each wing panel to its required outline, tapering the depth as seen on the front view. Shape each panel blank to its indicated rib sections and sand smooth. At the point of the landing-leg attachment to each panel score the upper surface, so that the wing may be cracked for the proper dihedral. Cement these weakened portions of the wings so that the desired amount of dihedral will be retained. Drill holes in the butt ends of the panels and force each panel in place on the fuselage dowels, cementing copiously. Mold the fillets with plastic wood.

Cut and shape the landing gear legs from  $\frac{1}{4}$ " sheet balsa, sanding each unit well before cementing and pinning it to the wing.

Carve the propeller from scraps and mount it on a straight pin so that it is free to turn. (Turn to page 94)

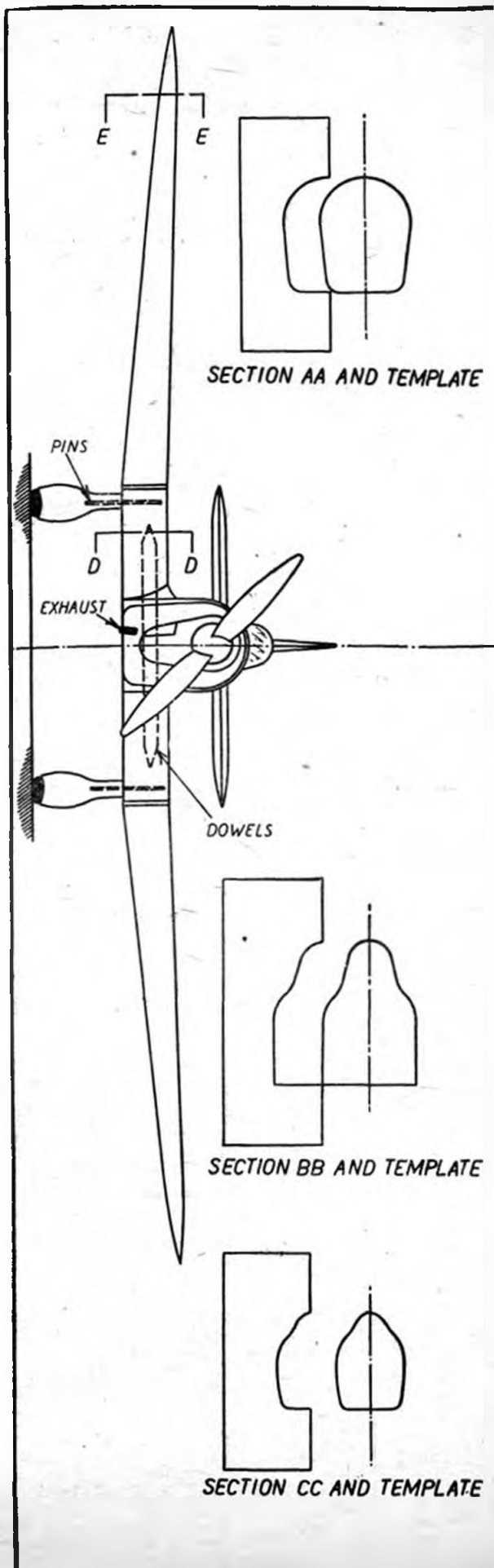

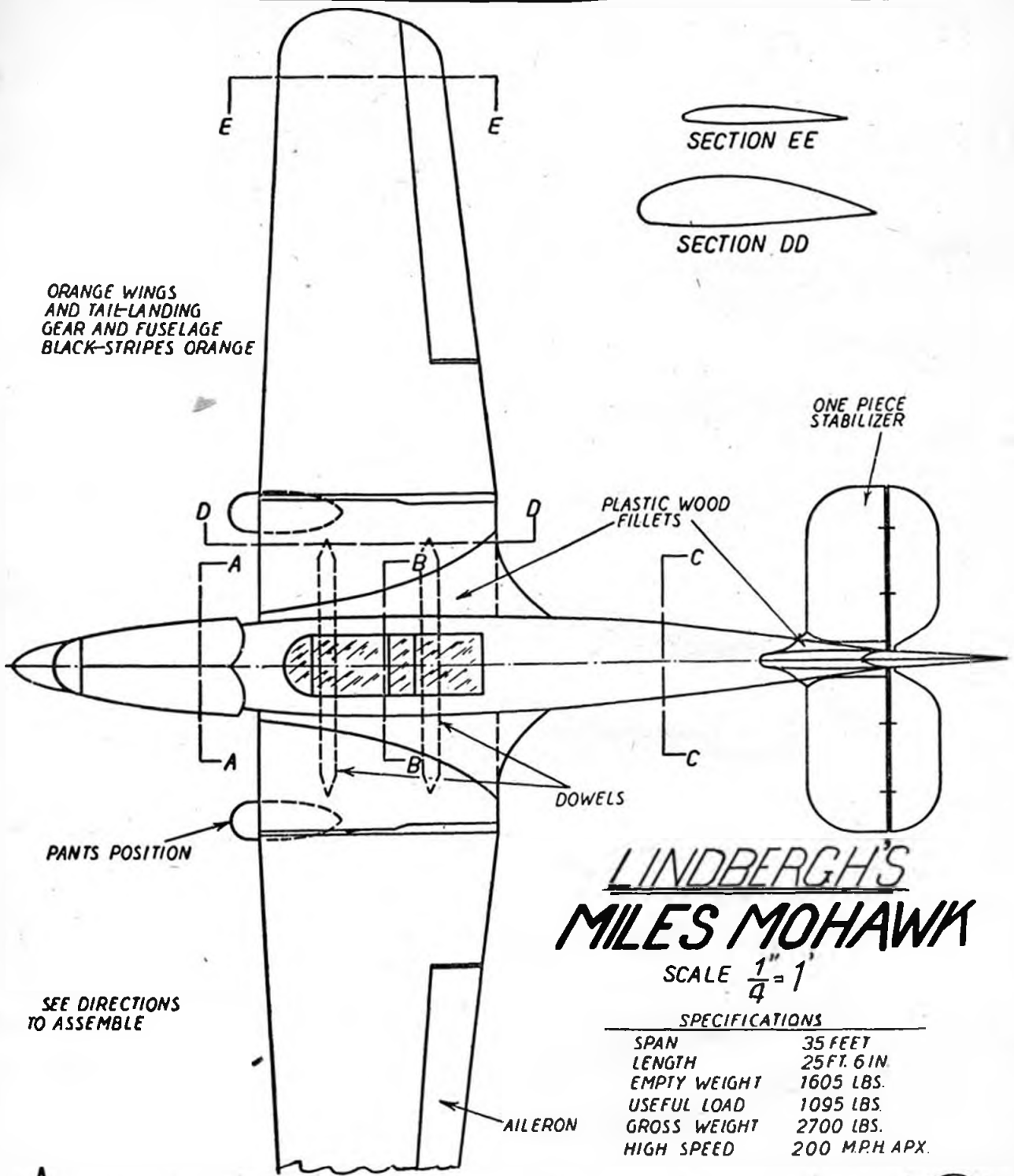

# LINDBERGH'S MILES MOHAWK

SCALE  $\frac{1}{4} = 1'$

SPECIFICATIONS

SPAN	35 FEET
LENGTH	25 FT. 6 IN.
EMPTY WEIGHT	1605 LBS.
USEFUL LOAD	1095 LBS.
GROSS WEIGHT	2700 LBS.
HIGH SPEED	200 MPH APX.

SEE DIRECTIONS  
TO ASSEMBLE

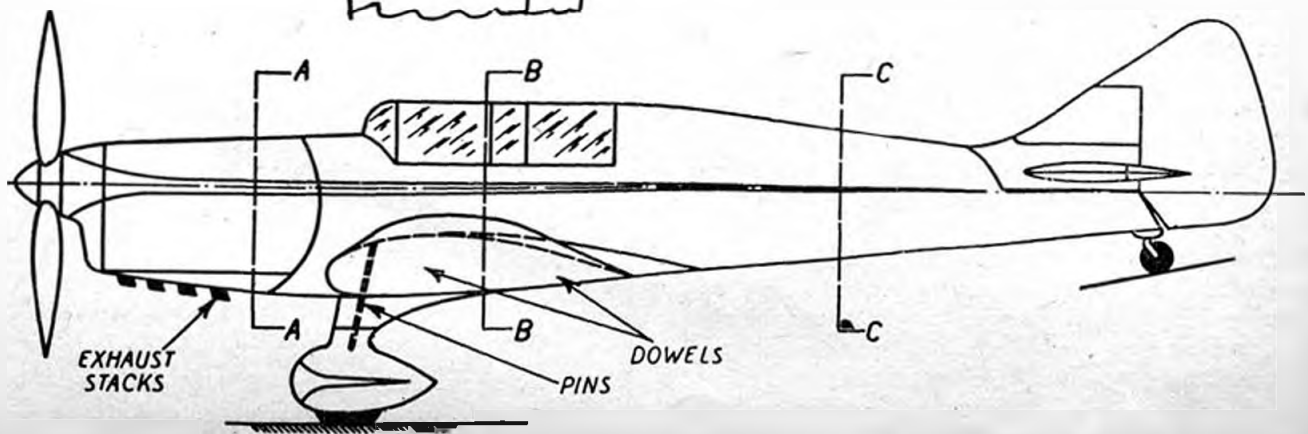

# Designing to Meet the New Wakefield Rules

by Gordon S. Light



The famous Wakefield Trophy for which the world's model builders have contested during the past nine years.

## WAKEFIELD CONTEST DURATIONS

YEAR	TIME	RULING
1928	52.6s	No weight requirements and best flight counted.
1929	1m 10.4s	"
1930	2m 35.0s	"
1931	4m 24.8s	"
1932	7m 57.2s	"
1933	5m 21.0s	Average of 3 flights
1934	1m 51.8s	Minimum weight 4 ounces for 200 square inches. Average of 3 flights.
1935	2m 30.0s	"
1936	4m 09.0s	"
1937	?????	Minimum weight 8 ounces for 200 square inches. Average of 3 flights.

**T**HE new Wakefield rules require a minimum weight of 8 ounces with a wing area of 190-210 square inches.

This means the minimum wing loading is one ounce per 25 square inches, or twice the loading used in the last three Wakefield contests. What can we do to maintain flying ability in the face of increased weight requirements? This is the question facing every designer whose ambition turns to recapturing the Wakefield trophy for this country.

The choice of methods for combating weight can be catalogued into two varieties. The first method has been used on models ever since weight rules were first introduced, about 5 years ago. The idea behind it is to build a model with a relatively short, powerful propeller run which will take it to sufficient height for a long glide. Even if the model does not pick up helpful currents, the sinking speed is slow enough to give satisfying duration.

This high-climbing variety of contest model has been so successful in recent years that it has discouraged any work on geared or multiple motor models. In every recent contest the modeler who has patiently developed a system of gearing, or other ways of increasing the propeller duration, has seen the lighter and simpler models carried out of sight on a thermal current. The smooth, steady flight, of average duration, turned in by geared models will not equal a thermal flight. And its slow climb and extra weight has made it less sensitive to thermal currents.

But the increase in weight requirements will close the gap between these two types of models. And this year, for the first time, the designer is called on to make an important decision—choosing between gears or a direct-drive single motor.

We've been doing some performance calculations for an 8-ounce model, to determine whether or not we can get worthwhile duration using a single motor without gears. For the purpose of calculations, we assumed a model of the same general characteristics as previous Wakefield entries. The only change, of course, was the increase of the weight. Doubling the weight means

doubling the number of strands of rubber required. However, the number of turns which can be stored in this motor (assuming 20 strands of  $\frac{1}{4}$ " flat rubber) is about  $\frac{1}{3}$  less than an equivalent length of 10 strands. The actual decrease in propeller duration would be greater than  $\frac{1}{3}$ , since it would be difficult to develop a propeller which would deliver sufficient thrust to fly an 8-ounce model and still maintain the same r.p.m. as the type used on a 4-ounce model.

Therefore, the larger rubber motor is certain to result in faster propeller speeds. It is not unreasonable to assume that for the same length of rubber the propeller duration on an 8-ounce model will be only  $\frac{1}{2}$  the duration of a 4-ounce model. At present, the propeller duration on the average contest model is about 60 seconds. Thus, in an 8-ounce model it would be 30 seconds.

The sinking speed on a heavier design suffers along with the decrease in propeller run. The glide angle of the model is not affected by weight as long as the "cleanliness" of the model remains the same. But the sinking speed is faster, since the velocity of the model along the glide path would be greater. Our calculations indicated that the sinking speed would be increased about 40 per cent. The sinking speed is about 2 feet per second with a 4-ounce model. And this would be boosted to 2.8 feet per second with an 8-ounce job. Sinking speed is what determines the duration of glide. So, in terms of total flight duration, it's likely that the total flight will be about 70 seconds. This duration will be equally divided between propeller duration and glide duration.

### CONVERTING INCREASED WEIGHT INTO RUBBER MOTOR

There is every reason to think that on an 8-ounce model it would be possible to convert much of the 4 extra ounces into additional rubber motor (Turn to page 93)

# SEVERSKY P-35

*A new all-metal fighter powered with 1000 h.p., two-row Pratt & Whitney Wasp, capable of 315 m.p.h. Army contract calls for 77.*

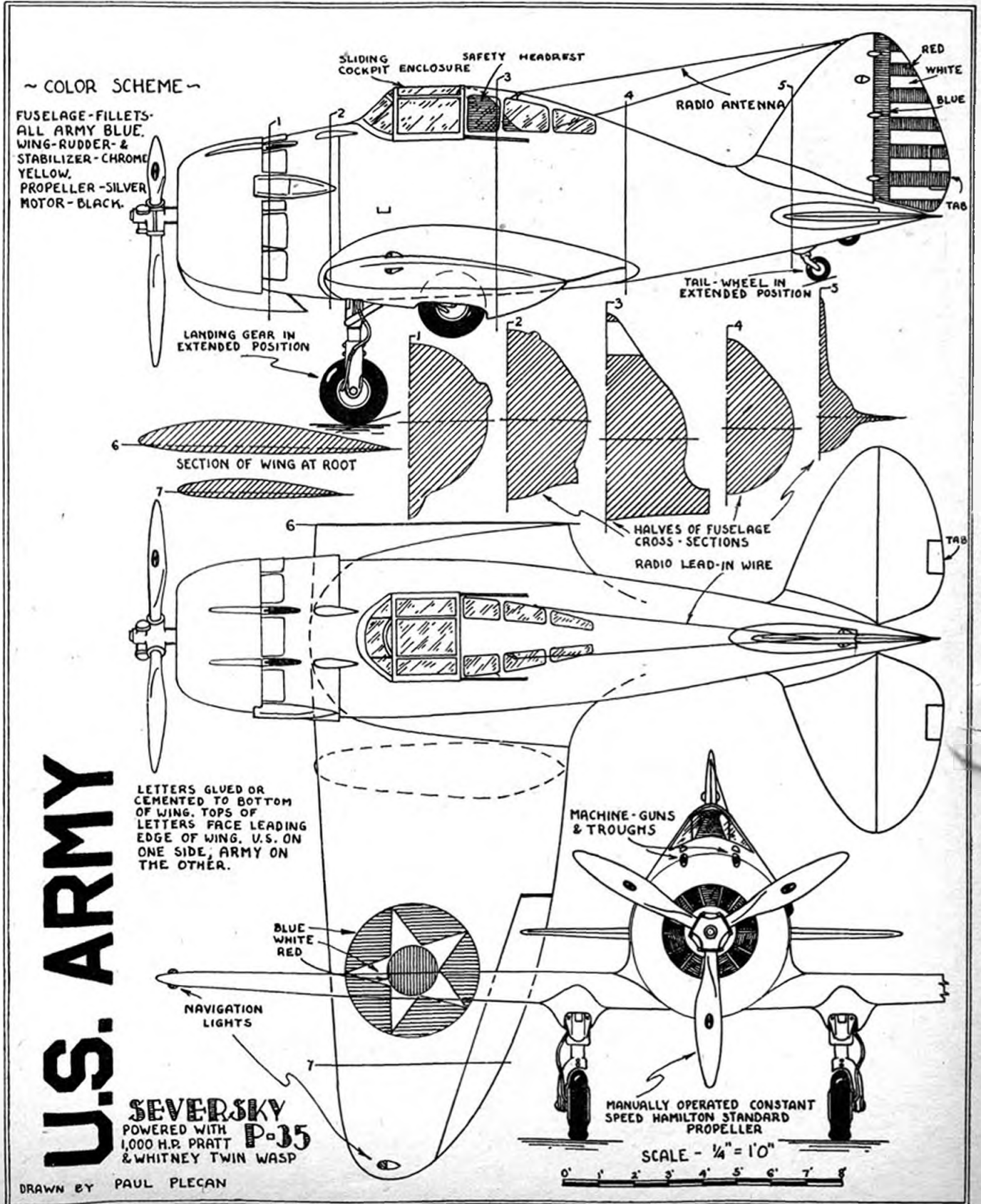

# EXPORT FIGHTER

*another solid scale plan*

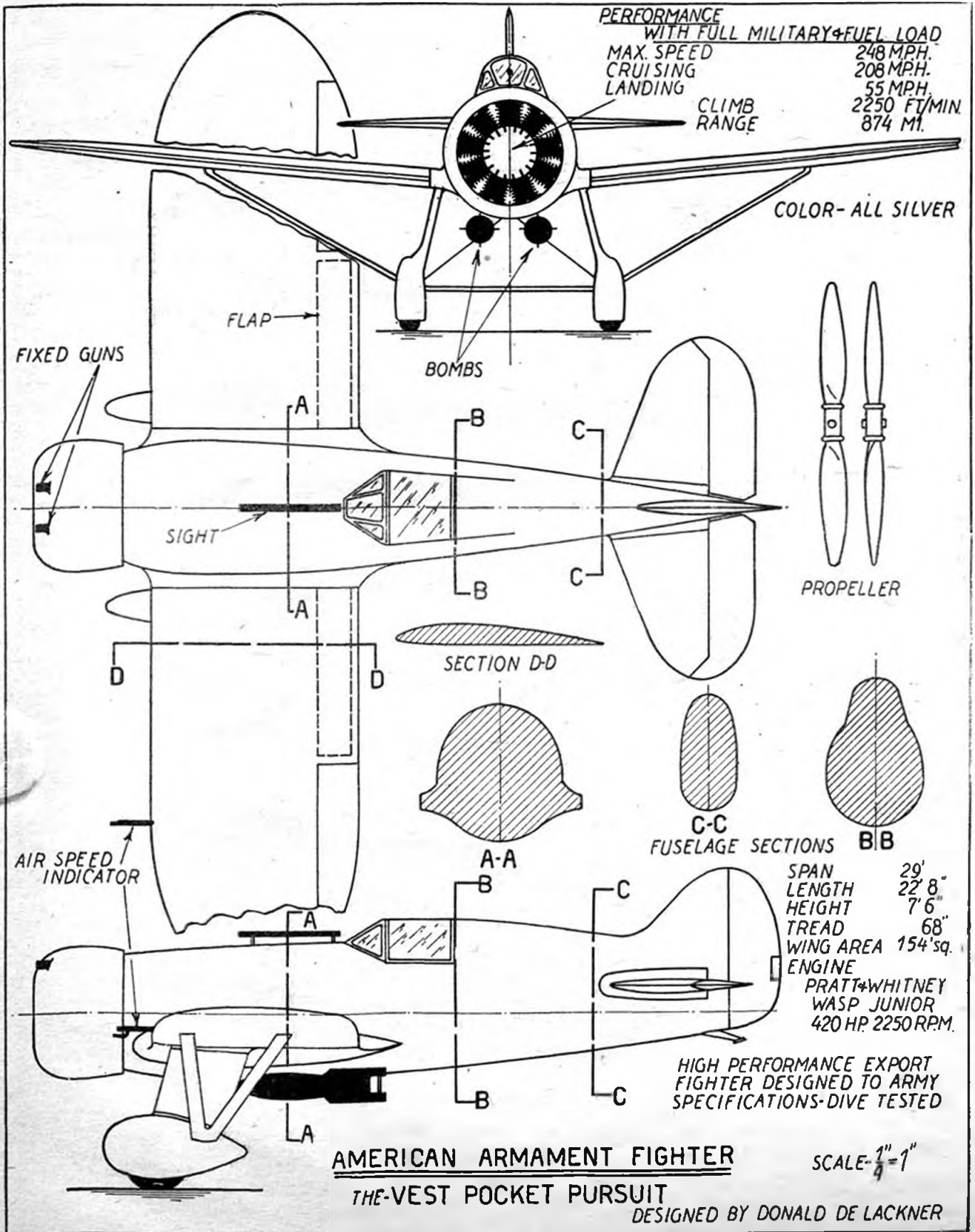

## DEATH RIDES THE SKY

(Continued from page 14)

"Nothing except what I said," Shorty answered. "I—"

A telephone bell pealed beside the little desk at the end of the laboratory. Bill glared at it, then moved across the room, took the receiver off the hook and grunted into the mouthpiece.

"This is 'Tony, Bill," the voice of the chief radio operator said in his ear. "Some bird who called himself Monkey Worts just made contact with me. He's flying here with another man to see you. I told him I didn't think you were here. He said he'd land and wait for you."

"Tell him——" Bill began, and then stopped. Something flashed in his mind, something he couldn't quite grasp. It was as though he was trying to remember a name that constantly eluded his memory. "Tell him," he said again. "I'm over in my living quarters. Send them over. I'm going there with Shorty in a few minutes."

He put the receiver back on the hook slowly. He was still trying to recapture the thing that had flashed through his memory. He shook his head and laughed.

"An old pal of yours is going to drop in to see us," he said to Shorty. Shorty lifted his eyebrows. "Tony said Monkey Worts is going to drop in with another man."

"Another rat, probably," Shorty said. "What the hell does he want around here?"

"I don't know," Bill said. "C'mon over to my bungalow and we'll find out."

Bill carefully locked both locks on the door of the laboratory from the outside. Then he motioned to a uniformed guard and told him to keep an extra sharp lookout over the laboratory.

As soon as Bill and Shorty were in Bill's bungalow he picked up the telephone on the desk in his living room and told Tony Lamport to send Cy Hawkins, another of Bill's veteran pilots, over to his quarters.

Both Bill and Shorty stepped to a window as they heard the high whine of a plane. It came in for a landing on Barnes Field. Bill did a *tsch, tsch* with his tongue against his teeth, as he saw the sleek, low-winged ship that came to a halt on the apron.

What he saw was a streamlined, low-wing, internally braced monoplane of sturdy design, built around a two-row, radial, air-cooled "ticker-gear" engine to drive a standard, controllable-pitch propeller with two blades. The twin Dart engine was inclosed in an N. A. C. A. cowling of the latest design equipped with air-control flaps.

The fuselage was of metal structure, covered with panels of smooth dural

plate as far back as the rear cockpit. The rear quarter was fabric-covered, also the aerodynamically balanced control surfaces. The rudder was provided with a trimming tab to compensate for engine torque. The twin cockpits were arranged in tandem and completely inclosed by sliding, transparent hatches.

"Do you see that machine-gun sight and the bomb racks underneath the center-section hatch?" Shorty asked Bill.

"I see 'em," Bill said. "That baby is fast—retractable landing gear—and it could do a lot of damage. I wonder why Monkey Worts is flying that kind of a job around the country?"

"He probably stole it," Shorty said. "But he'll tell you he found it in his stocking at Christmas time."

They turned away from the window as "Monkey" Worts and the man with him waddled out of the ship and unfastened their parachute packs.

"Keep your mouth shut and let him talk," Bill said. "What did the government ever do about that dope-smuggling charge against him?"

"They dropped it," Shorty said. "Monkey pulled a politician out of his hat and they couldn't get an indictment against him. I'd hate to have the things he has against him on my conscience."

"He probably doesn't have any," Bill said. "There is probably a bubble in his brain where his conscience ought to be."

Bill sat down in the chair behind his desk, opened the lower drawer and transferred an automatic from it to the top right-hand drawer, which he left open. When a knock sounded on the door he called out a cheery, "Come in."

Any one could have told why the man who first stepped into the room was called Monkey. He was a big man with a large-boned body and a powerful torso. But his head was too small for it. It sat directly on his shoulders, and it was small and wizened and battle-scarred. His eyes were small and rheumy, and the hair on his head was almost negligible. His eyes darted around the room as he stepped into it. His face cracked in what he thought was a smile, as he advanced toward Bill with outstretched hand.

"How are things going with you, Bill?" he asked, as Bill reluctantly took his hand.

"Fair," Bill said and the absence of his famous smile was noticeable. "You know Shorty, of course?"

"Well," Monkey Worts said, as he moved toward Shorty, "it's an honor to see the boy who won the War again."

"Your wit," Shorty said, sourly, "is about as funny as your fa——"

"How are things with you, Monkey?" Bill interrupted, hastily.

"So-so, Bill. I want you both to meet my business associate, Mr. Marat."

The flat-faced man behind Worts nodded his bullet head at each of them without a change of expression. He was a short man, built along the same lines as a brick smokehouse. But Bill, watching him for a moment, knew he could move with the agility of a cat.

"Sit down, Mike," Worts said to Marat, as he threw himself into a chair.

Bill sat down behind his desk and Shorty took a deep, leather chair near a window. Marat leaned back against the wall where he had been standing. He, evidently, preferred to remain on his feet.

"You got a great place here, Bill," Worts said, "a great layout. I see you even got tennis courts and a swimmin' pool. How many hangars you got?"

"Six," Bill said.

"An' a crash truck an' fire engine an' ambulance," Worts went on. "An' your own power house an' factory."

"You seem to know all about it," Bill snapped.

"I been lookin' you up, Bill," Worts said. "I think maybe you an' me can get together."

"What's on your mind, Monkey?" Bill asked again.

"I got a good line-up, Bill. I got something good. All you got to do is contribute your name, your field and be technical adviser," Monkey said.

"Technical adviser to what?"

"My new air line," Monkey Worts said. "I got a great proposition for you, Bill. We can go in it on a fifty-fifty basis, if you've got some cash to put in along with your airport as our Eastern terminal."

"What routes are you going to fly?" Bill asked, politely.

"Oh, I thought I mentioned that," Worts said. "It'll be just like it has always been—a transcontinental route from coast to coast. We'll use the same airports Amalgamated used from here to the coast and on the little side lines up the west coast."

Bill did not show by the flicker of an eyelash the way the mention of Amalgamated Airways really affected him. He glanced at Shorty, and when he returned his gaze to Worts there was a bland little smile on his lips.

"What has Amalgamated to do with it?" he asked, quietly.

"Ain't you seen the papers?" Monkey Worts wanted to know. "They know they're washed up—finished. They're going to lose their franchise and license. I got a ninety-day option on the whole works for a song. A couple of boys I know on Wall Street are



going to form a syndicate to furnish me with the dough. Then they'll float an issue of stock to pay themselves back, with a little added. The stock don't have to pay no dividends and you and me get the gravy. See?"

"I see," Bill said. "I should think you'd need a lot of money to buy all of Amalgamated's equipment."

"Not so much," Worts said, grinning. "They got the old pressure on 'em. See? They got careless and had too many accidents. These friends of mine are putting the pressure on 'em. See? They're glad to get out. These friends of mine are big shots—'way up! They'll give you the same protection they give me. See? An' with your name behind the thing, Bill, we'll clean up. We'll make plenty sugar."

Bill could feel a white-hot anger surging through his body. He pretended to look at a paper on his desk, to hide the thundercloud that came storming over his face. He knew, as surely as he knew it was daytime, that Monkey Worts had something to do with the inglorious deaths of Marty Dewart and Jerry Winsor and their passengers. He clenched his teeth and dug his finger nails into the palms of his hands to get control of himself. He knew that Monkey Worts had more things to tell him and he wanted to hear them. He wanted to hear them before he lost control of himself and threw Worts through the window or smashed his face in. He cleared his throat, whirled around and looked out of the window for a moment, stalling for time.

"Do you think there was any sabotage connected with those accidents on Amalgamated's lines, Monkey?" he asked as calmly as he could.

Monkey Worts studied him for a moment and then a slow, knowing smile broke over his ugly face. He winked one eye and curled up the corner of his

"I don't know, Bill," he said. "What do you think?"

"I think you're a filthy rat!" Shorty Hassfurther said, as he came bouncing out of his chair. He reached Worts in two strides, grasped him by the throat and yanked him to his feet. At the same instant he drove his right fist against Worts' nose with all the strength in his powerful shoulders. Worts staggered backward and slid to the floor, as Marat bounced off the wall with an automatic in his hand.

Bill Barnes read murder in Marat's eyes as he shoved the gun in Shorty's stomach. He knew that only a miracle could save Shorty's life. He started to reach for the automatic in the top drawer of his desk. Marat's cold, wheezy voice stopped him.

"Hold it, punk," he said, "or I'll kill both of you!" His gimlet eyes went back to Shorty. They were the eyes of

a man who likes to kill for the sheer joy of killing.

"Shall I let him have it, boss?" he asked the blood-smearing Worts as he heaved himself to his feet.

"In a minute," Monkey Worts rasped. "Hold your gun on him until I knock his teeth down his throat. If he raises a hand, give it to him in the stomach."

Worts steadied himself, while Bill stood helpless, with his hands flat on the desk before him. Worts' face was the face of an animal, as he moved toward Shorty, his big hands working convulsively.

Then Bill saw the door from the hallway opening slowly. He held his breath for what seemed hours, until he saw Cy Hawkins' leathery face peering through the crack. He shifted his eyes away from the door with an effort. He saw that Cy had taken in the situa-



Burt Longnecker.

tion and was ready to act. But he didn't expect him to do what he did do.

Cy pushed the door open until it was wide enough to admit him. Then he took two quick steps and jabbed something into the back of the gunman, Marat.

"Hold everything!" Cy said in his soft drawl. "Drop that gun and get your hands reaching. And you, monkey-face, keep your hands out of your pockets."

As Marat started to whirl, Cy grabbed him by the collar and said, "Better not, tough guy, or you'll be wondering how your spine got in two pieces. Drop that gun!"

Marat dropped it and lifted his hands above his head. Bill grabbed at the automatic in the top drawer of his desk and trained it on him. Then Cy stepped out from behind Marat and picked his gun off the floor. As he straightened up he wiggled the index finger of his right hand. "Imagine shooting any one with that," he said with a grin. Bill realized for the first time that Cy had not been armed.

Cy studied the gangster's gun with no little interest. He acted as though

he and Bill were alone in the room. "Look at that automatic," he said. "He carries it in a shoulder holster and he has the grip and barrel casing cut down so no one can tell it's there. Very, very neat."

Bill grinned back at him and reached for one of the telephones on his desk, as a bell pealed. He motioned to Shorty to take the automatic he had in his hand.

"Yes, Tony," he said into the mouth-piece. He listened to what Tony had to say with a strange expression on his face. "Put him on," he said in a moment.

"This is Bill Barnes, Mr. Shipman," he said. "Yes, speaking." He listened to the voice at the other end of the wire for a moment.

"Right," he said. "I understand. I'll be at your offices within an hour. And I'll have some interesting things to tell you. A notorious pilot named Worts is here, trying to sell me Amalgamated Airways."

He slapped the receiver on the hook and put the telephone down on his desk with a bang. His eyes narrowed to mere pin points as he regarded the two racketeers in front of him.

"I'm in all right, Monkey," he said. "But I'm not going to play on your side. You'll never get Amalgamated Airways if I can prevent it. So far you mobsters have left the air lines alone—until yesterday. I don't know whether you had anything to do with those crashes yesterday, but I'm going to find out. And if you did, Monkey, you're going to burn for them."

"Listen, Bill," Monkey Worts whined. "there is still time for you to come in with us. You'll clean up—"

"Scram!" Bill shouted. "Get out of here and take your muscle man with you, before I get mad!"

#### IV—BILL GETS A JOB

TWENTY MINUTES LATER, Bill Barnes, dressed in a tweed suit, snap-brim hat, a white shirt with a soft collar, plain navy-blue necktie and tan brogues, stood on the apron beside the Silver Lancer, while Martin, the chief mechanic on Barnes Field, warmed it up. He was giving instructions to dour old "Scotty" MacCloskey, major-domo and head technician of his staff.

"You better spread the word for every one to be on the alert," he said to Scotty. "Be careful about who the guards admit. Monkey Worts may get it through his head that I'm going to block his attempt to grab Amalgamated. If he does, he'll use his usual methods to get rid of me."

"Don't worry about things here, boy," Scotty said. "We'll keep a couple of Snorters warmed up and ready to take off. Red Gleason and Bev

Bates will be back from Canada some time this afternoon. Shorty and Cy and Henderson are here if you need them—not to mention Sandy.”

A frown flitted across Scotty's face. He looked at Bill, cleared his throat and went on, hesitantly. "I've been wanting to speak to you about the lad, Bill. Have you noticed anything peculiar about him lately? He seems to be so preoccupied and quiet and he's been staying away from the field until all hours of the night. It isn't like him. Do you—er—suppose the kid is mixed up with some girl or something of the sort?"

Bill laughed. "I don't think so, Scotty—unless the girl is an airplane. He's probably thinking up some new gadget with which he is going to change the course of aeronautical history. Leave him alone."

"Oh, I'll leave him alone," Scotty said, hastily. "I'm only too glad to leave him alone. It's a relief not to be combing him out of my hair every few minutes!"

Bill laughed again and climbed into the forward cockpit of the all-metal silver bullet. He dropped into the bucket seat and adjusted the seat parachute. Then, he revved up the tandem-Diesel engines that drove the twin props in different directions. He listened to their full-throated roar.

He checked over his ammunition counters and his two .50-caliber machine guns and the 37mm cannon mounted in the V of the cylinders. His eyes ran over the flight instrument panel and the radio panel and he tested the yellow-and-green amphibian gear lights. He lifted the infra-red ray telescope that permitted him to see through fog, clouds or darkness, checked it and let it drop back to its folding position in a recess in the instrument board.

He lifted a hand of farewell to Scotty, when a thatch of reddish, blond hair stuck itself over the rim of the cockpit. The hair was followed by a bronzed face, in the center of which was a freckled nose and a pair of laughing blue eyes. The gap below the freckled nose, that was a mouth, tried to shout above the roar of the engines. Bill cut his throttles and pushed his ear phones off his ears.

"What do you want, cabbage?" he shouted.

"Hey, who's a cabbage?" Sandy Sanders, the kid veteran of Bill's squadron wanted to know. "I want a ride in your rumble over to the city. Scotty said you were going up to the seaplane landing on 31st Street."

Bill made a motion with his thumb and young Sandy went over the side into the after cockpit. He pulled out the ear phones and slipped them over his ears.

"Thanks for the lift, mister," he

# FREE!

WITH ORDERS  
OF \$1 OR MORE

## SPRAY for Your MODELS

## 1 DOZEN or SHEETS JAP. TISSUE

quality! Prove this to yourself! Learn why so many builders, dealers and clubs deal with SKYWAY! Dealers! Send for prices.

<p><b>18" BALSAs SHEETS</b></p> <p>1/32x2 ..... 5 for 5c 1/16x2 ..... 5 for 5c 3/32x2 ..... 4 for 5c 1/8x2 ..... 4 for 5c 1/4x2 ..... 3 for 5c 1/2x2 ..... 2 for 5c For 3" sheets, double above prices</p> <p><b>BALSAs PROP BLOCKS</b></p> <p>1/4x3x6 ..... 6 for 5c 1/4x3x8 ..... 7 for 5c 1/4x1x8 ..... 3 for 5c 1/4x1x12 ..... 2 for 5c 1x1/2x12 ..... 1 for 5c 1x1/2x15 ..... 1 for 7c For 36" lengths double above prices and add 10c postage</p> <p><b>15" Bamboo Sheet Celluloid</b></p> <p>1.16x1/2 ..... 8 for 5c Shredded ..... 40, 5c Japanese Tissue ..... 45c All colors, DZ. 10c Silver Super-fine Tissue ..... 5c DZ. .... 50c Thinner Best 1 oz. .... 5c 1 oz. .... 5c</p> <p><b>ORDERS 75c or</b></p>	<p><b>18" BALSAs STRIPS</b></p> <p>1/16x1/16 ..... 100 for 5c 1/16x1/8 ..... 35 for 5c 1/8x1/8 ..... 30 for 5c 1/16x3/16 ..... 20 for 5c 1/18x3/16 ..... 15 for 5c 3/32x3/32 ..... 30 for 5c 1/4x1/4 ..... 12 for 5c 1/4x1/2 ..... 6 for 5c 1/2x1/2 ..... 3 for 5c 1/2x3/4 ..... 3 for 5c</p> <p><b>18" BALSAs PLANKS</b></p> <p>1x1, 1 for ..... 4c 1x2, 1 for ..... 9c 2x2, 1 for ..... 15c 2x3, 1 for ..... 18c 2x6, 1 for ..... 35c 2x12, 1 for ..... 70c</p> <p><b>Clear Cement</b></p> <p>1 oz. .... 5c 1/2 pt. .... 25c 1 pt. .... 45c</p> <p><b>Wood Veneer</b></p> <p>20x30", 1 for ..... 9c 2 for ..... 17c</p> <p><b>Read</b></p> <p>1/32, 1/16" ..... 3 ft. 1c 1/8" ..... 3 for 2c</p>	<p><b>Wooden Wheels</b></p> <p>2 pair ..... 3c 1 pair ..... 2c 1 1/2" pair ..... 4c 1 3/4" pair ..... 4c 1 7/8" pair ..... 7c</p> <p><b>Celluloid Wheels</b></p> <p>3/8" pair ..... 5c 1/2" pair ..... 7c 1 1/4" pair ..... 9c 1 1/2" pair ..... 15c</p> <p><b>Balsa Balloon Wheels</b></p> <p>2 pr. 3c 1 pr. 2c 1 pr. 3c 1 pr. 5c 1 pr. 8c 1 pr. 14c</p> <p><b>PROP. SHAFTS.</b></p> <p>2 for ..... 1c</p> <p><b>PAUL-O-WINA JAP PROPS</b></p> <p>5" ..... 10c (add 5c per inch for brass up to 10").</p> <p><b>Machine Props</b></p> <p>5" ..... 4c (add 1c per in. for props up to 16").</p> <p><b>Rubber Meters</b></p> <p>1/16 sq. 20 ft. 5c 1/8 sq. 20 ft. 5c</p> <p><b>INSIGNIAS—</b></p> <p>French, American, English, German</p> <p>1 1/4" 4 for 3c 2" ..... 1c 1 sheet of 24, 5c</p> <p><b>Dummy Radial Engines</b></p> <p>1 1/2" Diam. .... 14c 2" Diam. .... 18c 3" Diam. .... 23c</p> <p><b>DOWELS, 1/8" 12, 10c per doz.</b></p> <p><b>SPOT WELDED ALUMINUM WHEELS</b></p> <p>1" ..... 6c 1 1/2" ..... 11c 1 3/4" ..... 14c</p> <p><b>Sheet Aluminum</b></p> <p>.003 sq. ft. 10c</p> <p><b>Alum. Tubing</b></p> <p>1/16", 3/16", 1/4" ..... 10c ft.</p> <p><b>ALUM. LEAF.</b></p> <p>2 sheets for 1c</p> <p><b>WIRE, 6 ft. 3c 36" lengths.</b></p> <p><b>NOSE PLUGS</b></p> <p>large, 10c doz. small, 5c doz.</p> <p><b>Miscellaneous</b></p> <p>Washers, 1/4" 1c doz. Sandpaper, 9x6, 5c Model Piles, 9x6, 5c Brushes No. 6, 5c Thrust Bearings, 1c Bushings, doz. 3c</p>
---	--	--

CASH OR MONEY ORDER—NO STAMPS—NO C. O. D.'s.

SKYWAY MODEL AIRCRAFT SUPPLY CO.

383 Seventh Ave.,  
Dist. B  
Brooklyn, N. Y.

shouted, as Bill released his brakes and kicked the ship around into the wind.

"What's this I hear about your staying out until all hours of the night?" Bill asked into the intercockpit phone after he had leveled off at three thousand feet.

"Aw, that's a lot of hooey," Sandy said. "I've just been seeing some shows, Bill. I'm going to see a matinee this afternoon."

"You're going to sit in the Lancer and keep your eye peeled, while I call on Benjamin Shipman of Amalgamated Airways," Bill said, decisively. "I'm not going to leave it moored at 31st Street without some one to keep an eye on it, with Monkey Worts in the background."

"Hey, Bill!" Sandy shouted. "I got a date. Honest. What's that bandit Monkey Worts got to do with it?"

"You can telephone and break your date," Bill said. He told Sandy about Monkey Worts' call.

Sandy exhaled his breath in a resigned sigh and said, "O. K., Bill. I suppose if you need me I got to stick around. But you might have told me before I—"

"Before you what?" Bill growled.

"Let's skip it," Sandy said.

Bill circled once above the East River, until a string of barges were out of his way. Then, fishtailing to reduce his speed, he struck the water with a cloud of spray and roared up to the landing. The floats of the big ship slid halfway up the face of the inclined turntable. The turntable came up and swung halfway around. An attendant wheeled up a set of steps and Bill emerged. He hurried up the pier toward the row of waiting taxis.

A girl, with too much rouge on her cheeks and an inclination to flirt when Bill gave his name, told him Mr. Ship-

man would see him immediately. A boy directed him into the inner office and led him down a hallway to a door with Mr. Shipman's name on it. The boy rapped on the door and opened it. Bill stepped into the room. Shipman came out of his chair with his hand extended, as Bill crossed the room in three strides.

"This is quite an honor, Mr. Barnes," he said. "I have always been curious about you."

Bill smiled, shook Shipman's hand and sat down in a chair beside his desk. He saw immediately that Shipman was one of those men who go far on their personality.

He was a big man, with large features and a black head of hair that was gray at the temples. The touch of gray gave him a distinguished appearance. His brown eyes were clear and quite frank. Bill judged his age at fifty-five and decided he was going to like him. He knew that Benjamin Shipman was a very wealthy man and served on the board of a score of large corporations. He also knew Shipman hadn't inherited his wealth. He had earned it. He had fought his way up from the bottom, with that combination of ruthlessness and sagacity that is necessary in the modern business world.

"What do you think about this mess, Barnes?" Shipman asked.

"It looks to me like wholesale murder," Bill said grimly. "Monkey Worts knew a great deal more about the thing than he told me."

"Who is this Monkey Worts?" Shipman asked.

"A notorious and extremely skillful pilot," Bill answered. "He has been mixed up in everything from aerial dope smuggling to gun running in China. He is one of those warped characters you

read about in fiction. His face is warped and his brain is warped. He's an aerial gangster, if you know what I mean."

"Using his knowledge of planes and as a pilot to make any dishonest money he can?" Shipman suggested.

"Exactly," Bill said. "I asked him if he thought there was sabotage connected with the accidents on the Amalgamated lines yesterday and he gave me a knowing grin, winked and asked me what I thought."

"U-ummp!" Shipman grunted deep down in his throat. "What kind of a proposition did he make you?"

Bill told him about Monkey Worts' visit from beginning to end. When he finished, Shipman was gazing at him with eyes that were mere slits. He sat silent for several minutes, with the tips of his fingers together, his index fingers touching his lower lip.

"Do you think you can clean this thing up, Barnes?" he asked, finally. "I mean, clean it up to the satisfaction of the department of commerce, the newspapers and the public?"

"I can try," Bill said. "I'm as much interested in wiping those smears off the book of aviation as you are. They are a dark blot that it will take some time to erase. There are a number of angles I don't understand. To all appearances, and according to the records, Marty Dewart was riding the radio beam right up to the time of his crash. Yet he was fifty miles off his course. I can't understand that. And there are other angles."

"Then you'll take on the job?" Shipman asked. Looking at Bill at that moment Shipman could understand why Bill had won himself an international reputation for great accomplishments.

"I'll take it," Bill said, shortly, "on condition I can go about the thing in my own way. It seems to be a question of getting Monkey Worts with the goods, before he gets Amalgamated. I think I can get him."

"I'm sure you can, Barnes," Shipman said, grimly. "I wouldn't care to have you out gunning for me. What will you do first?"

"I'll hop down to Washington this afternoon and have a little talk with the air bureau of the department of commerce about the radio beam. I want to learn if there is any way a person could throw a fake beam that might lead a pilot off his real course and into the side of a mountain."

"You think that's possible?"

"I don't know," Bill said. "But I'll find out. Then, to-night, I'll hop out to Denver and Summit and take a look at those crack-ups. They have been left as they were? I mean, as much so as possible while taking out the bodies?"

"Yes," Shipman replied. "Burt Longnecker, our traffic manager, suggested

that we get in touch with you. He said you would want to see the ships."

"Burt is a good man," Bill said. "I'll keep in touch with you. You can always reach me through my radio station on Barnes Field. I'll have your full support?"

"Absolutely!" Shipman said, earnestly. "I'll back you with everything I have, Barnes. It's to my advantage. I don't see how Amalgamated can survive unless you do the trick. But take care of yourself. I don't want to have your blood on my hands."

"I usually manage to get through in one way or another," Bill said, as he got to his feet. He returned Shipman's strong grasp on his hand, touched his forehead in a half salute and marched out of Shipman's office without another word.

#### V—AN AERIAL DUEL

AN HOUR LATER Bill made contact with the radio dispatcher on Bolling Field in Washington. He got the direction of the wind and the ceiling, and twenty minutes later took the Lancer skimming across the field for a workmanlike landing.

"All right, kid," he said to Sandy, as he killed his engines and went over the side, "sit tight. I'll get back as fast as I can."

"You're certainly making a fine heel out of me," Sandy said. "You've always told me promptness in keeping an engagement was an important thing. I'm three hours late now!"

Bill took two steps and then wheeled around. "Listen!" he shouted. "Why do you make dates when you're supposed to be on duty? What do you think you're being paid for? Your beauty? If you hadn't come sticking your nose over the side of the Lancer, asking for a ride, you'd been able to slip out and stay out half the night, the way Scotty says you've been doing. Now, pipe down and stop sulking like a baby. If she loves you she'll wait a week for you." He watched Sandy's freckled face turn from pink to a deep crimson.

"She!" Sandy said with scornful dignity. "I'm not talking about any 'she.' I'm talking about keeping my word, about honor. I—" He waved one hand in the air. "I—"

"Yeah," Bill said, "you'll have yours cooked medium rare with four pounds of French-fried potatoes and a whole pumpkin pie."

He grinned and started toward the administration building and a taxicab. "What," he asked himself, "is that kid up to now? He's more trouble than two sets of quintuplets."

"What I want to know," Bill said to Clement Siebert, expert in the radio division of the department of com-

merce, "is if another broadcast could break in on the regular radio beam sent out by the department of commerce and take a man fifty miles off his course?"

"No," Siebert said, slowly. "That is, I don't think it could. Just how do you mean?"

"Like this," Bill said. "The pilot is riding the beam straight along the airway. The interlocking A and N are coming in regularly, and he knows he's on his right course. Then, he deviates off his course a little to starboard and the dash-dot, dash-dot signal comes in. Just as he is about to kick his rudder to get back on his true course, this fake range beacon cuts in with the regular interlocking A and N. It is louder than the real radio-beam signals and he thinks he is back on his true course. So he settles back in his seat, sure that he's on his course O. K. And the next thing he knows he sticks his nose in the side of a mountain. The fake beam has taken him way off his course."

Clement Siebert's angular face turned a shade paler; his mouth dropped open as he stared at Bill.

"You think that's the way that accident happened on Amalgamated the other night?" he asked.

"Could it happen that way?" Bill insisted.

"I suppose it could," Siebert said, slowly. "But who would want to do such a thing as that, Bill?"

"Then it could happen?"

"Why—er-r-r—I'd want to talk to some of our engineers before I answered that definitely, Bill," Siebert said. "It's a fantastic idea. Just a moment, I'll be—"

"Never mind," Bill said, and he grabbed Siebert's hand and pumped it. "That's close enough. You've told me what I want to know."

YOUNG SANDY sat breathless in the rear cockpit of the Lancer, while Bill related, over the intercockpit phone, what Siebert had told him.

"Good gosh, Bill!" he said, finally. "That's just plain murder."

"That's what it is, kid," Bill said. His face was a grim study in concentration as he opened the throttles of the Lancer and stuck the nose toward Barnes Field.

"You think Monkey Worts cooked that up?" Sandy asked.

"No," Bill said, decisively. "There is some one behind Monkey Worts. He is a crafty pilot and he'd murder his own family, if there was any money in it, but this mess is a little too deep for him to work out. He's probably doing the strong-arm stuff."

Bill glanced anxiously at the low-hanging, cumulus clouds and the fog that was gathering in the hills below them as the sun crept toward the hori-

zon. He flicked his radio key and chanted Tony Lamport's call letters in the microphone. When Tony's voice came back to him he asked him about the surface wind and the ceiling on Barnes Field.

"ESE wind, Bill," Tony told him. "But you've only got a thousand-foot ceiling. It's closing in fast. You better whip up your horse."

"Thanks, Tony," Bill said. "I'm signing off."

Bill nosed the Lancer down to a thousand feet to get out of the clouds and spoke to Sandy again. "You get ready to—" he began, but he didn't finish. He didn't finish because the screaming roar of a diving plane drowned out the drone of his Diesels and he could feel machine-gun bullets drumming into the tail assembly of the speeding Lancer.

"Break out that swivel gun!" he roared to Sandy, as he saw a low-winged monoplane race beneath them. He could tell by the tone of the engine that it was a twin Dart, and he knew without looking again that it was the ship *Monkey Worts* had landed on Barnes Field that day.

He stuck the nose of the Lancer down in a half-inverted loop or bunt and rolled it right side up at the bottom. The monoplane had eased out of its dive and was chandelling back to meet him.

Bill's face was livid with anger as he opened his throttles and raced head-on toward the sturdy monoplane. He knew the monoplane had been waiting there in the clouds to attack and that the pilot had expected to get him with that first burst of fire from his guns. And he knew that with *Monkey Worts* at the controls, with his eye glued to his telescopic sight, he was lucky that he didn't get him. He had learned two years before that *Monkey Worts* was a dangerous man behind a pair of machine guns. He could fly and he could shoot.

He estimated the distance that separated them as about five hundred yards, as he rolled out of that bunt. His fingers played with the electric gun trip on the control column as the two ships raced at one another at terrific speed.

Bill eased back on the stick and stuck the nose up a little as he rolled the Lancer over on its back, then stuck the nose down again as he rolled right side up. At the same instant his finger clamped down on his trigger. His powerful .50-caliber guns belched fire and lead in the dim light, as he got the monoplane dead under his sights from above.

But in that same instant the pilot of the monoplane slipped his ship off to the right, out of range of Bill's deadly aim. The two ships roared by one another and Bill heard the *tat-tat-tat* of Sandy's .30-caliber flexible gun as he brought it into action, followed immedi-

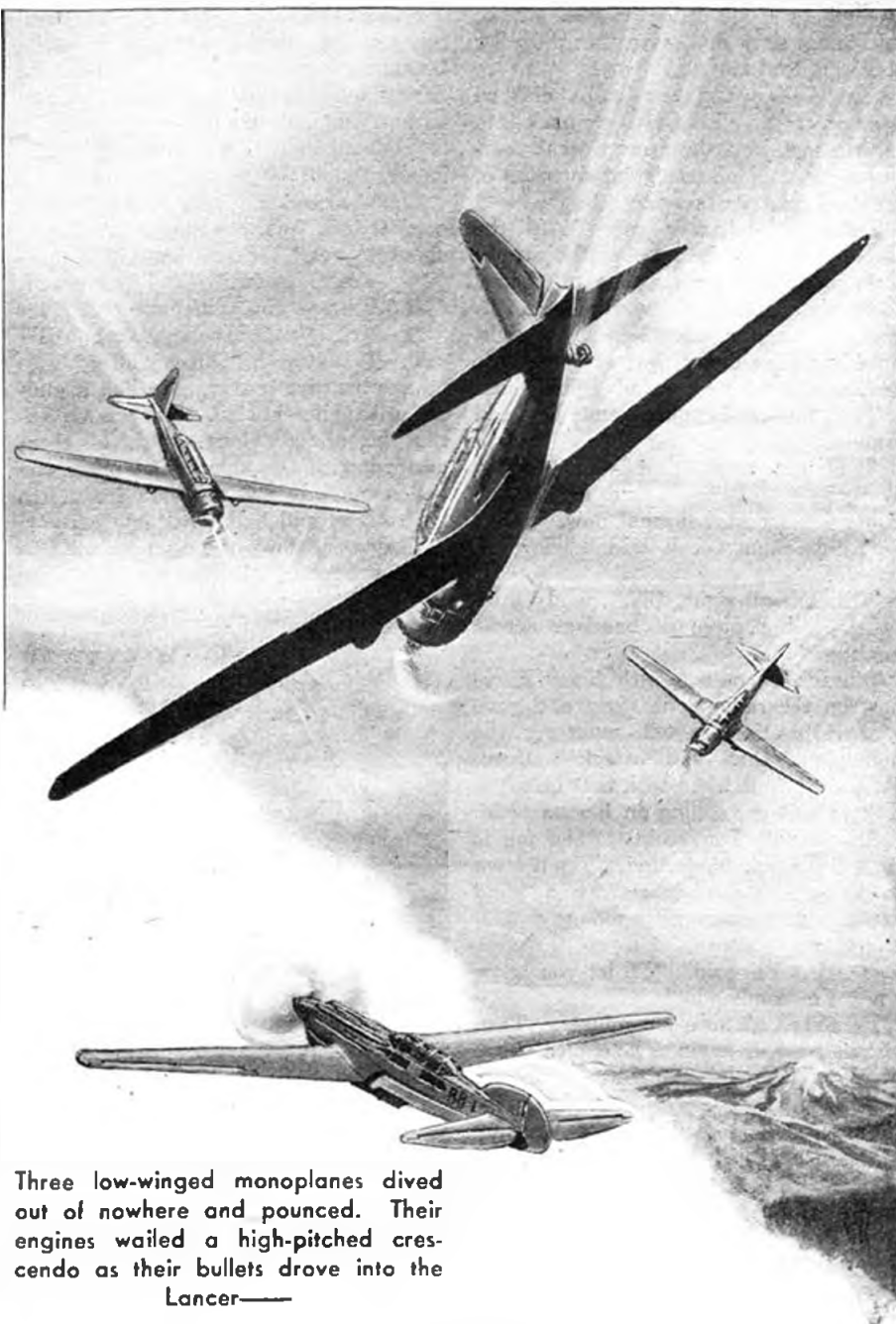

Three low-winged monoplanes dived out of nowhere and pounced. Their engines wailed a high-pitched crescendo as their bullets drove into the Lancer—

ately by the chatter of a swivel gun from the monoplane.

Suddenly, Bill's blood ran cold as he heard a half moan from Sandy. He shouted into his microphone, and when the kid didn't answer he swung around in his bucket seat and glanced over his shoulder. He saw Sandy sitting still, holding a hand that was smeared with blood to the side of his face.

"What is it, Sandy?" he bellowed. He saw the monoplane racing back at him, trying to get under his tail, and he stuck the nose of the Lancer straight up and opened the throttles.

"It's nothing, Bill," Sandy gasped in a moment. "A bullet just creased my cheek bone. It knocked me silly for a moment. I'm all right."

"You sure, kid?" Bill asked, anxiously.

"I'm sure," Sandy answered. "Stick the nose down and let me get a crack at that gunner. He almost knocked my head off."

But Bill didn't need any encouragement from Sandy now. He was so mad that he could feel the blood pumping through his body. He stuck the nose of the Lancer down as the monoplane raced up to meet him.

The combined speeds of the two ships must have been over five hundred miles an hour, too fast for accurate shooting, as they raced at one another again.

But this time Bill remembered, as he took his sight, that the ship had slipped off to the right before. He got the speeding monoplane's nose under his sights and clamped down on his trigger. Then he kicked his rudder ever so gently to correct his aim. He saw

his bullets smash into the nose of the oncoming ship and saw the propeller shatter into a thousand pieces.

Just before the two ships crashed head-on, Bill pulled the stick back into his stomach and the Lancer went roaring upward like some great monster of ten thousand years ago.

Before the Lancer raced into the clouds Bill saw the nose of the sturdy little monoplane drop. The tail began to oscillate and then the nose began to spin. As it disappeared from his sight he saw a lone figure dive over the side and saw his chute open up behind him.

Then the low-hanging clouds hemmed him in.

"Do you think that was Monkey Worts, Bill?" Sandy asked in his ear. His voice sounded normal now.

"No one but," Bill said. "How do you feel?"

"Oh, I'm all right, Bill," Sandy said. "I slapped a piece of bandage across my face."

Bill made contact with Tony Lamport on the radiophone again and gave him instructions about reporting the monoplane that had attacked them. When he had finished with that he asked Tony about the ceiling on Barnes Field.

"It's zero," Tony said. "The fog is right down on the ground. You'll have to use the radio signals for a blind landing and your infra-red ray telescope."

"O. K.," Bill said. "I'll let you know when I'm coming in."

He signed off for a few minutes. Then picked Tony up again as he circled above his own field and got the direction of the wind.

"All right," he said, "I'm coming in."

He lifted the infra-red telescope out of its recess in the instrument panel and sighted down the old-fashioned stereoscope eyepiece. The fog opened up before him for five hundred yards. It was as though some invisible hand had swept it aside with a broom.

But his face was strained and tense as he stuck the nose of the big ship down to glide in for a landing. He knew that with the Lancer kissing the ground with its wheels at seventy-five miles an hour anything might happen. Too much stick and he and Sandy might go to the hospital to never come out.

He glued his eyes against the eyepiece of the telescope and held the stick with the delicacy a surgeon uses for an operation on the eyeball. The ground came out of the fog to meet him. He eased back on the stick with the true touch of a master. The big wheels touched the ground and then the auxiliary nose wheel came down. The yellow-and-black stripes flashed under his wings, lighted by the flush border lights and his landing lights. His flaps cut down his speed as he rolled up the illuminated runway to the concrete apron and set his wheel brakes.

Scotty MacCloskey and "Red" Gleason were standing on the apron as he brought the ship to a halt. Bill helped Sandy over the side and told Scotty to hurry him to the infirmary.

"He's all right, Bill?" Red asked anxiously.

"Just a crease," Bill said. "Come over to my quarters and I'll tell you about things. Where's Shorty?"

"I don't know," Red answered. "Who jumped you, Bill?"

"I think it was Monkey Worts," Bill said. "It was the same kind of ship he flew in here to-day. He had a gunner with him—probably that same gorilla he brought here. One of them crashed with the ship. The other one bailed out. It was too dark for me to try to land and find him."

They went down the concrete walk to Bill's bungalow. Bill opened the door



Monkey Worts.

to the living room and snapped on the light. As the room was flooded he put up a hand and signaled to Red.

Red saw the broad back of a man sitting at Bill's desk with the chair swung around. An automatic popped into Red's hand from nowhere.

"Who is it?" Bill half shouted. But even as he said the words his stomach turned over and he knew. For an instant his knees nearly buckled beneath him. Then he was across the room and whirling the chair around. The thing he saw there almost completed the rout of his stomach.

As Bill whirled the chair the head of the thing that was sitting there lolled down at a grotesque angle. Great brownish stains spread over the front of his coat, and Bill saw that his throat had been slit from ear to ear and his mouth was propped open to show that his tongue had been cut out.

"Monkey Worts!" he said to Red in a breathless whisper.

#### VI—FUGITIVE

"SOME ONE," Red said, "took a delicate way of telling you Monkey talked too much. They're trying to tell

you you have a red-hot potato in your hand and you'd better drop it."

"It's a cinch Monkey wasn't piloting the ship that jumped me this afternoon," Bill said, slowly.

"Not with that throat trouble bothering him," Red said, dryly. "He has been dead a couple of hours. You'd better report this quick, Bill. It looks to me as though Monkey might have been planted here for a reason."

"It's a warning to me to keep my nose out of Amalgamated's trouble," Bill said. "I'll telephone the commissioner of police. He'll take care of it for me."

Before he called the commissioner, however, he threw ethics to the winds and went through Monkey Worts' pockets. They were entirely empty.

Tony Lamport located the commissioner at his home, dressing to attend a banquet. His voice was apprehensive and not a little cold as he came on the telephone.

"Now what has happened out there, Bill?" he asked.

"It's a murder, commissioner," Bill said. "And we've got to keep it hushed up for the time being. There are several angles I must tell you about. How soon can you get out here?"

"I don't know," the commissioner answered. "I'm scheduled to make a speech at a banquet. I've got to go because 'the boss' will be there. You're going to get yourself into some serious trouble one of these days, Bill."

"I've been in serious trouble lots of times," Bill snapped back. "Does this thing come under your jurisdiction, or doesn't it?"

"I'll send Inspector Winnie with a couple of his men," the commissioner answered. "He'll notify the coroner and the medical examiner. I'll get out there as soon as I can."

There was an expression of pensive wonder on Bill's face as he slowly put the receiver back on its hook. He sat down in a chair and his eyes wandered over the horrible figure of Monkey Worts without seeing it.

"Anything wrong, Bill?" Red asked. "I mean, what did the commissioner say?"

"He's sending Winnie out," Bill answered, thoughtfully. "This thing is all screwy, Red," he said after a moment. "Monkey Worts told me he had a ninety-day option to buy Amalgamated and all its equipment. Shipman said they had given no option."

"But that's of no importance. I mean, it looked at first as though Monkey knew what he was talking about. It looked like a cut-and-dried case. It looked as though Monkey and some of his mob had decided to muscle in on the air lines the same way other mobs have muscled into the laundry, the hauling, the artichoke business. The air lines

were right down Monkey's alley. So, he went to them and told them he wanted a cut—or else.

"They told him to go lay an egg or count the shingles on his grandmother's house. That made him mad and he arranged those four crack-ups that have occurred on their lines to make 'em listen to reason. After those two crashes yesterday he saw a chance to grab the whole works for very little money. So, he came to me in all seriousness. A crook like Monkey thinks every one's mind works like his own. If it doesn't, he thinks they're crazy.

"That's the way it looked to me early to-day. But now I know I was wrong. Monkey was only an errand boy in an organization that is ruthless and deadly. He got ideas, and thought because he was the muscle man of the organization he could muscle in alone. He talked too much."

"And there he is," Red said.

"And there he is," Bill repeated. "I thought it was going to be easy to clear the thing up. I should have known better. Monkey didn't have the brains to engineer anything as big as this is going to be. It's just history repeating itself."

"How do you mean?"

"The railroads went through the same thing when they were first being built and organized. When competition got tough they hired muscle men and the gangster of that day and age to tear up tracks, beat up train crews, destroy freight. Some one is smart enough to know that the air lines are coming into their own before long. They know they'll be carrying passengers and express and freight, with planes that weigh three and four and five hundred tons. It's progress—from the horse to the railroad to the automobile to the airplane. They're getting in on the ground floor and using any means to get control.

"There are brains and money behind this thing, Red," Bill finished. "And I'm right back where I started from when I saw the papers to-day. With Monkey dead, I don't have anything to work on."

"You can——" Red began, when a knock sounded on Bill's door.

"Come in!" he called.

A man with a red face, iron-gray hair, kindly blue eyes and a body like a ten-ton truck came into the room, followed by three other men.

"Hello, Bill," he said. He shook hands with Bill and Red Gleason and introduced the men with him. Bill already knew Sergeant Heath, one of the men. "Now," Inspector Winnie said, "what's wrong, Bill?"

Bill pointed at the blood-smeared figure draped grotesquely on the swivel chair.

"Yeah, I noticed him," Inspector Winnie said. "Looks as though he'd

had a little trouble. What do you know about it?"

"This has got to be kept out of the papers until I get a chance to do some work on the thing behind it," Bill said. The inspector nodded and Bill told him everything that had happened that day.

"You have no idea how they got Worts back in here?" Winnie asked.

"Not the faintest," Bill said. "I haven't had a chance to check that part yet. I landed and came right over to my bungalow. But if any one on the field had known anything about it Scotty MacCloskey would have told me when I came in."

A few minutes later the medical examiner and more detectives arrived. They spread powder over everything in the room and shot pictures, looking for fingerprints. They took photographs of the body from all angles. Then a couple of men covered the body of Monkey Worts with a sheet, laid it on a stretcher and took it out to an ambulance.

"Any diagnosis, doc?" Winnie asked the medical examiner as he was about to go.

The medical examiner looked at him in disgust. "Not definitely," he said, grinning, "but I suspect some one cut his throat!"

"We'll want to do some work around this room, Bill," Winnie said. "Is it all right if we close it up and put a guard here?"

"Yes," Bill said. "I just want to get a few things. I'm going to hop out of here within an hour."

"Where are you going, Bill?" a voice behind him asked. Bill whirled and saw the mustached face of Commissioner Barton. He was wearing a dinner jacket draped over his shoulders and a scowl on his face. His beady black eyes bored into Bill like gimlets. "What's this all about?" he barked.

Bill told him. When he had finished, one of the telephones on Bill's desk rang. It was some one who wished to speak to the commissioner. Bill saw the commissioner's eyes dart toward him, then widen in surprise.

"Anything more to tell me?" the commissioner asked after he had hung up the receiver.

"Nothing of any importance," Bill said. "You can talk to Scotty MacCloskey. You know him."

The commissioner nodded.

"Why can't we talk to you?" he asked.

"I'm going to get the Lancer warmed up and hop for Denver," Bill said. "I have a feeling—a horrible feeling—that these crashes haven't ended. Things are beginning to shape up in my mind now. Probably from talking about the thing with you and the inspector. I have a very slight suspicion about those two crashes, and if I'm right there may be more of them."

**Read this Letter . . . . .**  
**one of the many we have received**  
*"Having received the last order, I am more than pleased, especially the texture of the Balsa. How do you manage to sell such excellent material and yet keep the price so low? No company has yet sent me such fine materials for so low a cost. Wishing that every model builder would give your company a try, I remain*  
*Sincerely yours, (Signed) Lorán Brunoe*  
 331 Washington Ave., Peru, Ind.

**QUALITY 24 HOUR SERVICE** HEADQUARTERS FOR GAS MODEL SUPPLIES  
 Send 2c postage for catalog  
 With all orders for \$1.00 or over—your choice of one (only) of these FREE OFFERS

- 1. Large bottle clear cement and 100 1/16x1/16x18 balsa
- 2. 50 ft. 1/2 flat rubber
- 3. 3 sheets silver tissue
- 4. 1 sheaf 1/2 flat rubber. Add 15c packing charge for offer No. 4

**FREE**  
 Free Postage on all Orders in United States for 75c or over. Except West of Miss., add 10c; Canada, U. S. Possessions, and Foreign, add 15c. Foreign Under \$1.00 add 15c. No C.O.D.'s. No Stamps.

Send 2c Postage For Catalog

<b>PROPELLER BLOCKS</b>	<b>CAMEL'S HAIR BRUSHES</b>
1/2 x 3/4 x 5 8-5c	Small 3c; Lee, 5c
1/2 x 1/2 x 4 5-5c	Extra large, .8c
3/4 x 1 x 3 4-5c	<b>NOSE PLUGS</b>
3/4 x 1 x 2 3-5c	1/2" dia. . . . . 10c
3/4 x 1 1/2 x 10 5-5c	<b>DUMMY RAD. ENGINE (Colu.)</b>
3/4 x 1 1/2 x 12 5-5c	1 1/2" d. 18c; 2" d. 20c; 2 1/2" d. 25c.
1 1/2 x 1 1/2 x 12 4-5c	<b>ENGINE AND COWL (Colu.)</b>
1 1/2 x 1 1/2 x 15 6-5c	1 1/2" dia. . . . . 13c
<b>SHEET ALUMINUM</b>	2" dia. . . . . 20c
.000x36" 1c	3" dia. . . . . 25c
.005 in. 6x6 6c	<b>CELLULOID PANTS, per pair</b>
.010 in. 6x6 6c	bottle, 8c; 1/2 pt. 15c; 1 pt. 17c
<b>CLEAR DOPE</b>	<b>METAL PROPELLERS</b>
5c per oz.; large bottle, 8c; 1/2 pt. 15c; 1 pt. 17c	2 blades 3 blades
<b>THINNER</b>	1 1/2" . . . . . .08
Same as clear dope	2 1/2" . . . . . .10
<b>COLORED DOPE</b>	3" . . . . . .15
5c per oz.; large bottle, 8c; 1/2 pt. 15c; 1 pt. 17c	1 1/2" . . . . . .20
<b>CLEARCMENT</b>	2 1/2" . . . . . .25
5c per oz.; large bottle, 8c; 1/2 pt. 15c; 1 pt. 17c	<b>ALUM. TUBING</b>
<b>MACHINE CUT Balsa</b>	1/16, 3/32, 1/8, 3/16 or 1/4, ft. 10c
1/2" 4c; 3/8" 5c; 1/4" 6c; 5/16" 7c; 3/16" 8c; 1/8" 9c; 1/16" 10c	<b>ALUM. COWLINGS</b>
<b>BAMBOO</b>	1 1/2" 15c; 2" 18c
1 1/2 x 1 1/2 x 12 3c	Specify whether anti-draw or closed
1 1/2 x 1 1/2 x 15 4c	<b>BOMBS</b>
1 1/2 x 1 1/2 x 18 5c	3/4" 4c; 1 1/4" 7c; 1 3/4" 10c; 2" 12c
<b>DOWELS</b>	<b>GUNS WITH RING MOUNT</b>
1/16x1/16x12 3c	1 1/2" 10c; 1 3/4" 12c
1/16x1/16x15 4c	<b>PURSUIT MACH. GUNS</b>
1/16x1/16x18 5c	3/4" 1 1/2" or 1 3/4"
<b>WIRE</b>	Specify 5c
6-8-10-12-14	<b>BUSHINGS</b>
1/16" 2 ft. 1c	1/16 . . . . . 4 for 1c
<b>WOOD VENEER</b>	<b>WOOD WATER SPRAYER</b>
20x30 . . . . . 1 for 10c	1 1/2" 15c
<b>PAPER</b>	<b>MODEL PINS</b>
BAMBOO 2 for 15c	1/2" or 1" pk. 5c
<b>CELLULOID</b>	<b>SANDPAPER</b>
6x8 . . . . . 5c	10z. sheets, 5c
12 1/2 x 16 . . . . . 10c	<b>PROP. SHAFTS, REAR HOOKS</b>
<b>WING AND TAIL LIGHTS</b>	1/2" 10c; 1" 15c
2 1/2" 20c	<b>MODEL STANDS</b>
<b>REED</b>	Small . . . . . 15c
1/32-1/16-1/8	Large . . . . . 25c

**20 IN. FLYING PLANS 10c-3 for 25c**  
 Sparrow Hawk, Boeing Trans. 247, Spad Chass., Veught Corsair, Curtiss Swift L. W., Waco Cabin Biplane, Douglas Dolphin, Boeing P12F, Fokker D-VIII, B.E.3, Goshawk, Gee Bee, Boeing P26A, Mancooper Northrop Gamma, Fairchild 24 Cabla, Corben Super-Ace.

**SELECT ANY 1 OF THE ABOVE PLANES 35c in 20" FLYING KIT Postpaid**  
**Dealers: Send for Wholesale Price List IMPERIAL MODEL AERO SUPPLY**  
 416E McDONALD AVENUE BROOKLYN, N. Y.

**COLT 45 CAL. Frontier Model**



Basewood construction kit with working plans and all necessary hardware. Barrel and cylinder are machined. **\$1.45**

**COLT 45 Cal. "FRONTIER" model kit, .55**  
 COLT 45 Cal. "FRONTIER" model kit, 7" barrel, 1.70  
 COLT 45 Automatic Pistol Kit, 1.00  
 COLT 25 Cal. automatic pistol kit, .50  
 THOMPSON SUB MACHINE GUN model kit, 3.00  
 Savage Cal. 32 automatic pistol kit, .75  
 LUGER 9 M/M auto, pistol kit w/4" barrel, 1.70  
 LUGER 9 M/M auto, pistol kit w/6" barrel, 1.90  
 All kits make beautiful full scale models. Postpaid in U.S.A.  
**GUN MODEL CO., Dept. W24, 2908 N. Nordica Ave., Chicago, Ill.**

"They're out of our jurisdiction, Bill," Barton said. "But you can't leave here. I'll have to hold you until we get a little further on with this thing."

Bill looked at Barton as though Barton had slapped him in the face. He was both incredulous and indignant.

"You know I have nothing to do with Worts' death," he said.

"No," Barton said, "probably you haven't. But I've been in hot water a couple of times for letting you skip out of here after all hell had been blown to pieces. I can't do it this time, Bill."

"You mean," Bill said, completely amazed, "you're going to hold me here when a dozen lives may hinge on my getting away?"

"I mean just that, Bill," Barton said. He shifted his eyes away from Bill's gaze. "I've got to hold you. Probably we can arrange bail. Then you can do what you want to."

"Bail!" Bill said. "You're talking like a crazy man, Barton!"

"Maybe I am crazy," Barton snapped. "I just got orders over your telephone, Bill. The big boss tells me to keep you here. There isn't anything else I can do."

Bill stared at him with an expression of unbelief on his bronzed face. A hundred thoughts flashed through his mind that led nowhere. He could only stare and shake his head for a moment.

"Listen, commissioner," he said, and his face was ugly now, "do you mean to say some big-shot politician is having me held here because of the murder of a lousy racketeer?"

"That's the gist of it, Bill," Barton said. "Take it easy. Don't try to bat your brains out against a stone wall. This thing will be ironed out."

"Then there is some one way up behind all this," Bill said, half to himself. "Some one with enough power to muzzle justice."

"No one said that, Barnes," the commissioner rasped. "You want to learn to keep your mouth buttoned."

"Or I'll be picked up looking like Monkey Worts, eh?" Bill said. His face was a deep crimson and his eyes were angry red spots.

"O. K.," he went on. "I'm going over to the administration building to telephone Benjamin Shipman of Amalgamated Airways. I'll have to tell him he will have to get some one else on the job."

"That's sensible, Bill," Barton said. "When you're through, come back here. We'll want to go over this thing again. You can see there can't be any mistakes, with the big boss horning in."

"Yeah," Bill said, "I see." He motioned to Red Gleason and stalked out of the room.

"Listen, Red," Bill said, when they were halfway to the administration building. "get this straight. Slip over

to the hangars and tell Martin to make a quick check of the Lancer. Tell him to load in all the fuel she'll take and check my ammunition. Then have him warm her up. Let her idle so she won't attract Barton's attention. When she's warm tell him to roll her out so she's headed into the wind, ready to go."

Red cursed, bitterly and said, "You're taking a big gamble, Bill. You're really under arrest."

"Yeah," Bill said, "I know. A couple of Barton's flatfeet came out of my bungalow a couple of seconds ago to tail us. Barton isn't taking any chances. But I'm going to get away from here, Red. So help me!"

"It's the worst thing in the world you can do," Red said. "If you run away you'll practically convict yourself."

"Hell!" Bill said. "I'm not running away. I'm going to get the birds who are really responsible for all those murders. Some one powerful enough to make the commissioner listen to reason is behind this thing. There is no sense to Barton's holding me for the death of a gangster. It's just a plant to keep me here until Monkey's employers finish their job."

"Bigger men than you have been railroaded to jail, Bill," Red said.

"Nuts!" Bill answered. "You get over and do what I told you, while I get Shipman on the telephone."

Bill went into his office, lifted the telephone receiver and asked Tony Lamport to locate Benjamin Shipman and get him on the wire.

"Any ideas about finding him?" Tony asked.

"Well," Bill said, wrathfully, "don't look under your own hat. You know more about how to locate him than I do!" He heard Tony chuckling as he slammed up the receiver.

While he waited for Tony to complete the call he drew a lightweight white overall over his clothes and stuck a heavy automatic in a pocket. The phone rang while he was adjusting a white helmet and flying goggles. Benjamin Shipman's deep voice sounded at the other end of the wire.

"I only have a moment, Mr. Shipman," Bill said. "I just wanted to tell you that while I was coming back from Washington I was attacked by a ship similar to the one Monkey Worts flew in here to-day. I shot it down, thinking Monkey Worts was at the controls. But he wasn't. When I got back to Barnes Field Monkey Worts was sitting behind my desk, in my living quarters, with his throat slit and his tongue cut out. I——"

"Wait a minute, Barnes," Shipman said. "Tell me that again. I can hardly believe my ears."

Bill went over the thing again. He heard Shipman draw in his breath as he spoke of Monkey Worts.

"I called the commissioner of police and told him about it," Bill went on. "He's an old friend of mine and has helped me a hundred times before. But this time he's thumbs down. He insists on holding me for the murder of Worts. He tells me some 'higher-up' has given the order and he doesn't dare disobey."

"He can't do that, Barnes!" Shipman said.

"Maybe he can't," Bill said. "What I'm pointing out is that he is doing it! But I'm going to slip out of here in a few minutes, if I can. They'll be after me like a pack of bloodhounds. But I'm sure those two disasters yesterday are not the end. I want to get out there before another one happens."

"What makes you think another one will happen?" Shipman asked, breathlessly.

"It's too long a story to tell you over the telephone," Bill said. "I think another one is scheduled, and I think I know where it will take place. What I want you to do is use your influence with the commissioner and get to the man he calls the boss. If you don't they'll slap me in jail the minute I arrive in Denver."

"I don't know that I have any influence, Barnes," Shipman said. "But I'll do what I can. You'll keep me informed?"

"Yes," Bill said. "Through Burt Longnecker, your western traffic manager, or through Tony Lamport, my radio chief here."

"How soon are you going to leave?" Shipman asked.

"The moment I hang up this receiver," Bill said. "Good-by."

"Just a minute, Barnes," Shipman was saying into the mouthpiece, as Bill slapped his receiver on its hook. But Bill wasn't listening.

He had heard the door of his office open quietly while he was talking and he knew there was some one in the room. He turned around slowly. Sergeant Heath, one of Barton's crack men, stood smiling at him. But his smile was not a pleasant one. It curled up one corner of his mouth in a way that made it look more like a sneer than a smile.

"Going to take a little run-out powder, eh, Bill?" he said.

"What's on your mind, Heath?" Bill asked.

"You," Heath said. "I don't want to have to get tough with you, Bill, so just take it easy. The commissioner is waiting for you over in your bungalow."

Bill saw that Heath's arms were folded, and he also saw that his right hand was pushed down inside the left lapel of his coat. He knew Heath's right hand was curled around the butt of the automatic that rested there. He

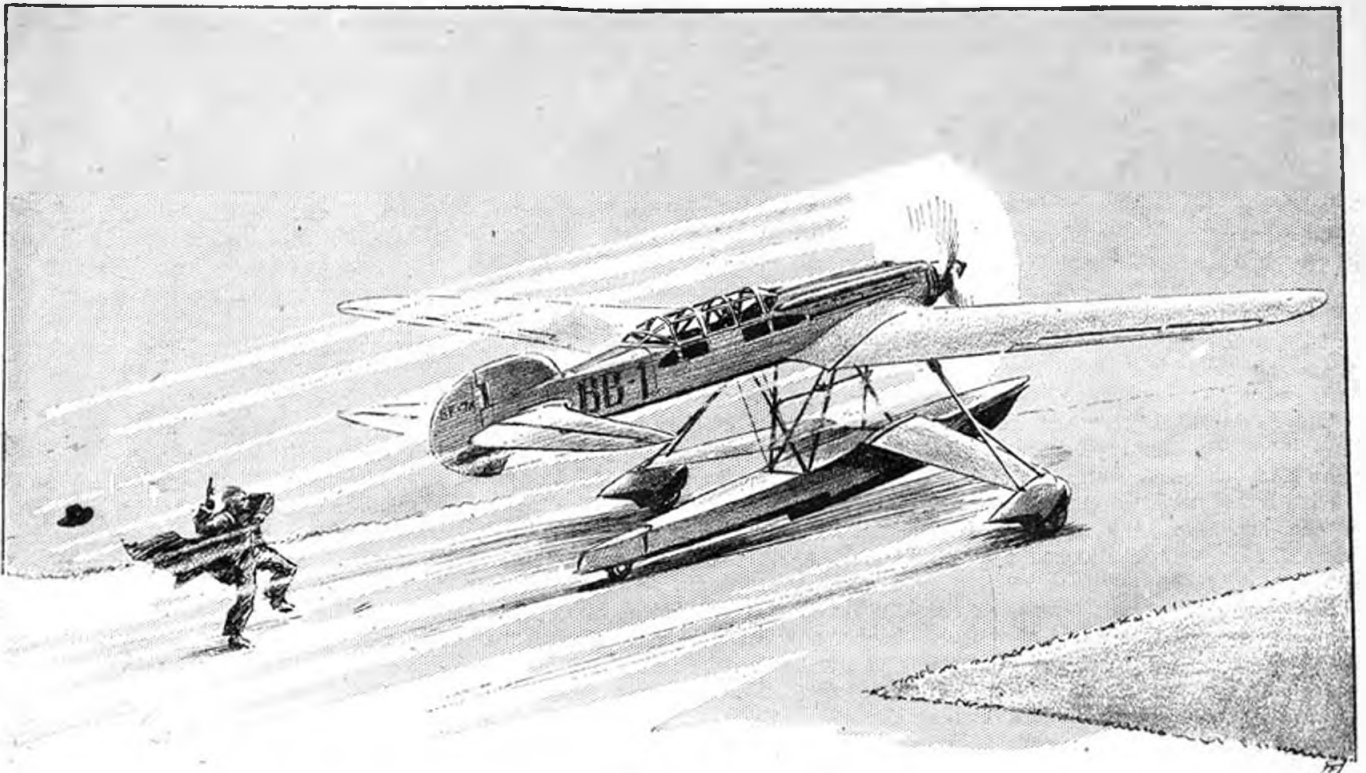

Bill literally dived into the front cockpit. He threw off the wheel brakes as he heard a shout and a shot behind him. He opened the throttle wide—

grinned at Heath, shrugged his shoulders and spread his hands in a gesture of resignation. At the same time he took a step forward, so that Heath was only two feet away from his left shoulder.

As Bill's lands dropped to his side his weight came forward on his left foot. At the same instant he pivoted on the ball of his foot and his right fist came up from his hip. When it exploded on the side of Sergeant Heath's jaw it cracked like the report of a small-caliber rifle.

Bill knew that with the strength and weight he put behind that blow Heath would fall forward on his face. He caught him as his hands dropped to his sides and his knees buckled. He eased him down to the floor and crammed his hat under his head.

He locked the door behind him and sauntered down the front steps of the administration building. He saw the props of the Silver Lancer turning over slowly on the main runway in front of the traffic tower. That would mean the wind was from the south.

As he rounded the traffic tower he saw two men that he knew were detectives hurry away from the front of Hangar No. 9 and come toward him.

He covered the distance to the Lancer in three long strides and literally dived into the front cockpit. He threw off the wheel brakes as he heard a shout and a shot behind him. His eyes skimmed over the instrument panel as he opened the throttles wide. He saw, out of the corners of his eyes, that

the two detectives were only ten feet away when the Lancer began to roll. His lips moved in a silent prayer.

Then the two giant props dug into the air. The Lancer went down the runway like a silver bullet. He eased the stick back and took it into the night in a long, low climb.

## VII—SNOW AND SLAUGHTER

BILL BARNES' whole body was trembling as he settled back in his bucket seat and wiped the perspiration from his dripping face. He snapped off his million-candle-power landing lights and the world became a huge black void around him.

As he took the big ship higher and higher, the crisp, fall air became chilling. He closed the hatch over his head. He saw a few flakes of snow flutter down on the hatch. He looked over the side. Long Island was a dim mass of blurred lights below him.

He continued to climb until he had twelve thousand feet under him. He knew that if he ran into a storm over the Allegheny Mountains the weight of the snow on his wings would begin to tell.

For one brief instant he wondered if he had been a fool to smack Heath in the jaw and run away. He knew that now he was nothing more than a fugitive from justice. Then, his mouth settled in a grim slash across his face. He knew that he was entirely on his own. The powerful interests he had had behind him so many times were

lacking now. He would have to accomplish the thing he had set out to accomplish, or he would be shown no mercy. His reputation and fame would do him no good if he was arraigned and tried for murder.

"Nor will the power of the men aligned against me help them if I can hang those murders on them," he said softly to himself.

That thought gave him courage. He flicked the key on his radio panel and spun the master tuning control. "Calling B. B. X. . . . Calling B. B. X. . . . Calling B. B. X.," he chanted into the microphone.

"Scram, Bill!" Tony Lamport's voice whispered in his ear. "Hell is popping. Signing off!"

Bill scowled as he threw the radio key and saw the ruby light on the panel vanish. He had now been cut off from the only contact he dared make.

But he forgot about that as the fury of the wind increased and snow began to beat against his windshield. The ascending and descending currents of air caused his compass needles to jiggle in crazy fashion. From each dial on the instrument panel came a pale, ghostly glow. His gyro compass and earth-inductor compass and turn-and-bank indicator were doing things that reminded him of toy acrobats on a swinging trapeze. He clenched his teeth and used all his powers of concentration on keeping on the course he had mapped.

The big ship dropped into pocket after pocket, slapping him against his safety strap. He slid upward on ascend-



ing currents of air and down on the other side like a small boat in a turbulent sea.

Suddenly, the blood in his body seemed to freeze, as a voice sounded in his ear. He glanced at the tumbler switch on the intercockpit telephone and saw that it was on.

There was some one riding in the rear cockpit of the Lancer!

The voice sounded in his ears again, but the terrific roar of the twin Diesels half drowned it out. He touched the switch and found that it was only half on. The voice came again.

"Hey!" it said. "If you're going to run away from the cops, why not go some place where it's warm?"

Bill's breath whistled through his lips in one explosive blast, as he swung around in his seat and looked over his shoulder.

Young Sandy's impish face glowed faintly in the phosphorescent glow from his instrument panel. The bandages underneath his helmet bulged the left side of his face. The straps of adhesive across his nose and chin looked like spokes in a wagon wheel. And he was trying to grin.

"What the hell——" Bill began.

But Sandy interrupted him. "Now take it easy, Bill," he said. "I'm not here because I want to be. Red told me you were going to take it on the lam and I climbed in the back to get my camera before you left. I had it with me this afternoon. That's what Scotty was talking about—my staying out until all hours of the night. I've been taking night pictures with infrared plates. I wanted to get my camera, so——"

"What the hell are you talking about?" Bill bellowed. "Why didn't you let me know you were there sooner, if I kidnaped you?"

"Well," Sandy said, "I didn't want to startle you. I thought I better keep my mouth shut. I didn't want you to get nervous and break both our necks. I thought——"

"You thought!" Bill shouted. "You thought! You never thought in your life. You're in a nice mess now. You'll be lucky if they don't hang you!"

"It won't cost them any more to hang two of us than one," Sandy said, but Bill wasn't listening now.

The storm was roaring at them like some giant monster, as they neared the Allegheny Mountains. He checked his bearings while he fought to keep control of the ship. And he was getting cold—not ordinary cold, but a clammy, nasty cold that clung to his skin.

He began to feel his way cautiously, carefully. He had to use every sense, relying as much on his touch, perception and instinct as he did on his instruments. He crouched forward over the stick to keep from having his back-

bone shattered against his bucket seat. He eased the stick back and coaxed the big ship upward, as a giant hand tried to press it earthward.

Just ahead of them, he knew, loomed the Pass. His altimeter read four thousand feet and he knew, also, that he had to have at least five thousand under him to get through safely. He pulled the control column back into his stomach and changed the pitch of his propellers. The ship responded slowly. But it began to climb.

The next thing of which they were really conscious was their glide down the other side of that dirtiest air strip in the world. The Lancer leveled off like a thoroughbred, and Bill fed juice into his engines.

"That was nice going, Bill," Sandy said. "I couldn't have done it better myself."

"Yeah," Bill growled at him. "Your boyish modesty almost makes me cry."

He stuck the nose of the Lancer on the two-million-candle-power beacon ahead. The night was clear as soon as they were over the mountains. The little villages that sailed behind them rivaled the constellations of the sky in brightness. They had a thirty-mile wind on their tail and Bill eased open the throttles of the Lancer to take advantage of it. The air-speed indicator crept past three hundred and fifty miles an hour, three seventy-five, four hundred, four fifty. There he held her.

The powerful engines sang their lullaby to the night as they flashed over Cleveland, Toledo and that great maze of twinkling lights that was Chicago.

Two hours later he left the beacons trail where prairie wagons once rolled and cut southwest toward Denver. The sluggish water of the South Platte River was barely discernible in the dim light of the early morning.

Bill's hand was wrapped tightly around the control column as he fought to stay awake. He was slumped down in his bucket seat, so tired he could hardly keep his swollen eyes open. He kept going over and over the events of the past day. He was trying desperately to put the jagged ends of the problem confronting him together. He wasn't surprised at any of the things that had happened. Too many things had happened to him in the past for him ever to be amazed at anything.

But he knew he must solve the problems before him now or it would be the end of his career. He had never before hit a policeman on the chin as he was about to be arrested for murder.

His head was nodding and his eyes were nearly closed when three low-winged monoplanes dived out of nowhere and pounced. They streaked down on the Lancer in a precipitous dive, with their guns blazing.

They raced down on him from three

directions. The Lancer was at the apex of their converged fire. Their engines wailed a high-pitched crescendo as their bullets drove into it.

It only took a split fraction of a second for Bill's mind and muscles to coordinate. He knew that he could not escape all of their bullets, but he hoped the terrific speed of the Lancer would save him and Sandy from being killed.

After that first fleeting glance upward, he bellowed Sandy's name in his microphone and yanked the stick of the Lancer back into his stomach. His lips were twisted back over his teeth as the three thousand horses in the nose of the Lancer lifted it vertically into the sky. It was all that saved them from annihilation. They actually shot upward inside those three converging streams of lead. They could feel the Lancer trembling under the impact of the bullets that drove through her. But for some miraculous reason Bill and Sandy were untouched.

As Bill came to the top of that vertical zoom he eased the stick forward to level off. The three ships had come out of their power dives and were zooming upward to attack again. Bill's body rode with the Lancer as he banked around and slapped the control column forward. He aimed the big silver ship dead at one of the climbing planes.

"Get ready to use your swivel gun if I miss him!" he shouted at Sandy.

"It's a fine way to wake a fellow up," Sandy muttered. "I'll shoot his lousy buttons off."

The low-winged monoplane that led the other two was nose-on for the diving Lancer. Bill held his fire as he saw lines of smoking tracers whip out from the other ship. He waited until he could feel lead smacking through the wings and belly of the Lancer. Then, for that brief instant that is enough, the fast, little monoplane came under his sights. His two powerful guns vomited their flaming cargo of death. It drilled through the length of the monoplane during that brief instant.

Bill saw the pilot jerk upward in his seat as though he intended to bail out to safety. Then he collapsed over his stick, as the ship yawed wildly and stuck its nose toward the never-ending mountains below.

Bill cursed savagely as he threw the Lancer out of range of the guns of the two remaining monoplanes. He wanted to follow those two ships upward and blast them out of the air with his 37mm cannon. But he didn't do it. He knew that they would have shown him no mercy if they had the upper hand. Yet he could see no point in shooting them down when he could not land beside them to question the pilots if they still lived. There was not a place within a hundred miles where he could have made a safe landing.

He banked the Lancer around, put it back on its course and opened his throttles. He could feel the ship surge ahead as the powerful engines roared. It seemed, in a moment, that the fast little monoplanes behind him were standing still as the two big air screws in the nose of the Lancer set their teeth in the air ahead. Bill couldn't help feeling elated as he felt that terrific surge of power. The spell was broken by Sandy's amazed voice.

"Hey, Bill!" he shouted. "You're going in the wrong direction. Those two ships are behind us. If you bank around fast you can catch 'em before they sneak away!"

"That's where I want 'em—behind us," Bill said. He knew the thoughts that were going through Sandy's mind. The kid had the idea that you should never stop fighting as long as there was anything in sight to fight.

"That," Bill said, "was only a stall to slow us up, shoot us down or disable us. Those three pilots knew they didn't have much of a chance to get the Lancer. Their hearts weren't in their work. They were just being used for cannon fodder to keep us from reaching Denver."

"Who sent 'em after us, Bill?" Sandy asked.

"I'd give a lot to know for sure, kid," Bill answered. "It's the same gang Monkey Worts was working for. The man at the top is gambling with everything he has."

"You got any ideas, Bill?"

"A couple," Bill said, grinning. "Shut up! I want to think."

He went over and over the course of events again, as they sped toward the city of Denver.

"The only person in the world who knows for certain where I am going is Shipman," he told himself. "I told the commissioner I wanted to go to Denver. But, of course, both of them are out of the picture. The question now is how I'm going to get in touch with Burt Longnecker without being thrown in the hoosegow for murder and running away."

"Hey, Bill," Sandy shouted in his ear. "hold her steady. I'm going to try to get a couple of pictures with my new infra-red plates and long-focus lens."

"O. K.," Bill said. "What will it do that any other camera won't?"

"It will take pictures of things at a distance that aren't even visible to the naked eye," Sandy said. "I want to try shooting it through your infra-red-ray telescope to see if I can get night pictures. It might work."

"It might," Bill said, automatically.

After he had tuned in on a station on the West coast he turned the wave-control dial again and began to chant, "Calling WVBD. . . . Calling WVBD. . . . Calling WVBD."

"WVBD. This is Station WVBD. Who is calling. Go ahead!" sounded in his ear phones.

"Private plane," Bill answered. "Private plane. I want to make contact with Burt Longnecker. . . . Burt Longnecker."

"Who is calling? . . . Who is calling?" the Amalgamated goat head asked. "Longnecker is here. . . . Longnecker is here. . . . Who is calling? Go ahead. . . . Go ahead."

"Private plane," Bill repeated. "Private plane. . . . Must make contact with Longnecker."

"WVBD to private plane. Will try to get Longnecker. . . . What is your wave length? Go ahead. . . . Go ahead."

"Will stay on your wave length," Bill answered. "Get Longnecker."

Bill very nearly held his breath while he circled high above the city of Denver—so high that from the ground the Lancer was only a tiny spot in the sky. He left his radio switch open and heard the ground operator at WVBD talking to Amalgamated planes in the air. Then another voice came from WVBD—a voice that Bill knew was Burt Longnecker's.

"WVBD calling private plane. WVBD calling private plane," he heard Burt's voice chant.

"Private plane answering. . . . Private plane answering," Bill said. "Want to make personal contact with you, Longnecker," he went on. "Where can we make personal contact with—"

"I understand!" Longnecker interrupted. "Will meet you on private field fifty miles north of Cheyenne in one hour. Stay in air and follow me in. Do you get it?"

"I get it," Bill answered. "I get it. In one hour."

"Keep your eyes open," Longnecker warned. "Signing off."

"Signing off," Bill answered.

He laughed softly as he threw his radio key. "There," he said to himself, "is another gimper—a guy who'll never let you down. All the real men seem to be in the air these days.

"Did you have your radio switch open?" he asked Sandy.

"Yeah," Sandy said. "He didn't even mention your name or anything. He's a smart guy. You think he's going to be able to tell you anything, Bill?"

"I hope so," Bill said. He brought the Lancer around in a long, sweeping bank and held the nose almost due north. He cut his throttles down as much as he dared in the thin air over the mountains.

**SAVE! SAVE! SAVE!**  
**BALSA SUPPLIES AT ROCK BOTTOM**

These prices apply only to orders for \$2.50 or over. ABSOLUTELY FREE WITH EACH ORDER. Rubber—no packing charge.

16" BALSA	PROP. BLOCKS	BUSHINGS
Per 200	PER DOZ.	1/16" I.D., 100 15c
1/16x1/16 . . . 8c	1/16x1/16 . . . 5c	WASHERS
1/16x1/10 . . . 8c	1/16x3/16 . . . 5c	PER 100
1/16x3/32 . . . 15c	1/16x1/8 . . . 12c	1/2 or 3/4 O.D. . . . 5c
1/16x1/8 . . . 15c	1/16x1/4 . . . 16c	MACHINE CUT
1/16x1/16 . . . 22c	1/16x1/10 . . . 25c	PROPS. per doz.
1/16x1/11 . . . 25c	1/16x1/12 . . . 30c	200 6" . . . 21c
1/16x1/2 . . . 60c	1x1 1/2x1 1/2 . . . 38c	300 8" . . . 35c
3/32x3/32 . . . 21c	1x1 1/2x1 1/2 . . . 52c	10" . . . 45c 12" . . . 60c
1/8x1/8 . . . 23c	<b>BEST BAMBOO</b>	WHEELS, doz.
1/8x3/16 . . . 47c	1/16x1/16 dia. . . .	Birch Bal. Cal.
3/16x3/16 . . . 55c	1/16x1/16x12	1/2" . . . .04 .05
1/4x1/4 . . . 78c	gross 15c	3/4" . . . .05 .10 .24
1/3x1/2 . . . \$1.50	<b>CLEAR DOPE</b>	1" . . . .07 .13 .25
1x1 . . . 2 for 6c	1 oz. . . . doz. 40c	1 1/2" . . . .09 .18 .35
1 1/2x2 . . . 2 for 8c	10c seller doz. 60c	1 3/4" . . . .15 .35 .60
2x2 . . . 2 for 11c	gross 6.75	2" . . . .15 .35 .60
1x1 1/2 . . . 2 for 11c	1 pt. 25c 1 pt. 35c	3" . . . .15 .35 .60
1x2 . . . 2 for 13c	1 qt. 65c 1/2 gal. 90c	<b>WIRE, 100 FT.</b>
2x3 . . . 2 for 32c	1 gal. each. \$1.50	No. 620e No. 1025e
1/64x2 20 for 16c	<b>COLOR'D DOPE</b>	No. 823e No. 1230e
1/32x2 20 for 14c	All colors	No. 14 . . . .35c
1/16x2 20 for 17c	1 oz. bot. dz. 50c	<b>PROP. SHAFTS</b>
3/32x2 20 for 20c	10c seller doz. 60c	1 gross . . . .45c
1/4x2 20 for 22c	gross 6.75	<b>NOSE BLOCKS</b>
3/16x2 20 for 31c	1/2 pt. 27c 1 pt. 45c	PER DOZ.
1/4x2 20 for 40c	1 qt. . . . .70c	1x2x1 5c 3x3x1 20c
3" sheets or 10"	1/2 gal. . . . \$1.25	2x2x1 12c 3x3x1 35c
lengths, double	<b>CLEAR CEMENT</b>	<b>RUBBER</b>
above prices and	1 oz. bot. dz. 40c	<b>BEST QUALITY</b>
add 10c packing	10c seller doz. 60c	2 1/2 ft. sheets
charge for 30"	gross 6.75	1/16 sq. . . . 25c
lengths.	gross 7.00	1/8 sq. . . . 25c
<b>JAP. TISSUE</b>	1/2 pt. 25c 1 pt. 40c	1/16 sq. . . . 25c
Silver, doz. 19c	1 qt. . . . .60c	1/2" NOSE
White, doz. 11c	1/2 gal. . . . \$1.00	PLUGS
1/2 ream 1.05	1 gal. . . . 1.75	1 doz. 5c 100 32c
Col. doz. 13c	1/2 gal. . . . 6.50	
1/2 ream 1.15	5 gal. . . . 6.50	

Remit with order. Because of these low prices, we do not pay shipping charges. No C.O.D.'s. No stamps. Send for complete price list.

**RELIABLE DEALERS SUPPLY**  
416E Gravesend Ave., BROOKLYN, N. Y.

**PICTURE PLAY**

gives you more for  
15c  
than any other movie magazine on  
the market.  
Get your copy to-day  
15c Per Copy

**AVIATION**  
**APPRENTICES**  
Ambitious, air-minded young men, interested in entering the well paid field of Aviation, write immediately, enclosing stamp, to  
**Mechanix Universal Aviation Service**  
Incorporated  
Strathmoor Station Dept. T Detroit, Mich.

**CLASSIFIED DIRECTORY**

An opportunity to contact a large field on a small lineage. Rate 10c per word (Minimum 20 words). Cash with order. Address:

**AIR TRAILS CLASSIFIED ADVERTISING**  
79 Seventh Avenue, New York City

**Miscellaneous**

HUBBER thread—Hodgman Rubber Co., New York—261 Fifth Avenue; Chicago—412 No. Wells St. Dealers and Manufacturers only.

**Model Airplanes**

FREE GIFT with every balsa sheet stripper purchased \$3.55 postpaid. Litwin Bros., 474 East 98th St., Brooklyn, N. Y.

JUST OUT!!! BOY'S catapult glider. Hand or catapult launched. 15c each, no stamps. Atlanta Gliders, Box 64, Sta. C, Atlanta, Ga.

**Instruction**

GET 1937 GOVERNMENT JOBS. Start \$105—\$175 month. Men—women. Prepare now for next announced examinations. List positions, FREE. Write today. Franklin Institute, Dept. B18, Rochester, N. Y.

VIII—ARRANGEMENTS

BILL threw the switch on his radio and twirled his master tuning control—then the volume and wave-length con-

Within forty minutes Bill was circling high above a small, private airport fifty miles north of Cheyenne. Both he and Sandy had closed their overhead hatches and Sandy had turned the valve that supplied oxygen from one of the two tanks beneath the bucket seat in the after compartment.

Sandy was first to see the two-place light cabin, *Meredith*. It came up fast, circled the little landing field and swooped in for a landing.

Bill stuck the nose of the Lancer down in a vertical power dive from twenty thousand feet. The roar of the tandem Diesels in the nose rose to a high-pitched scream as it plunged toward the earth at terrific speed.

Both Sandy and Bill were opening and closing their mouths like fish out of water to take the pressure off their ears. The gale that screamed by the big ship was like the wail of a million banshees.

"Hey!" Sandy shouted into his microphone.

"All right, kid," Bill bellowed back, "I'm coming out!"

They both opened their mouths and began to shout at the top of their voices to prevent them from "blacking out" as he eased the control column back. For one frightful moment it seemed that the Lancer was going to shake itself apart. It did not seem possible that anything could withstand that terrific pressure.

Then, the nose came up and Bill took it down in a series of shallow dives. They saw Burt Longnecker standing on the ground beside his little monoplane and Bill waved an arm over the side as he came around in a steep bank and fishtailed in for a landing.

"You don't care whose neck you break, do you?" Burt Longnecker grinned as they slid over the side and shook his hand.

"I wanted to get down here fast to get the dope," Bill said. "Let's have it, art."

"There is a hush-hush alarm out to pick you up for murder, assault, resisting arrest and—" Longnecker began.

"Do the papers have it?" Bill asked.

"No. The police are stepping very easy. But it looks as though you were in a real jam, Bill." Longnecker's forehead was creased in a frown. "Who are you supposed to have killed, Bill?"

"Monkey Worts," Bill said and he told Longnecker the things that had happened during the past day. When he had finished with that he asked, "What is your opinion about those two crashes day before yesterday? Were they accidents or were they rigged?"

"I think they were rigged, Bill," Longnecker said. "I'm almost certain of it. The control cables on Jerry's ship looked as though they had been smeared with something that ate right through them. And some one planted a bottle of whisky in Jerry's office. It broke in the crack-up and looked bad for Jerry."

"What about the other one?"

"There wasn't enough of it left to get any clues," Longnecker said. "It's a cinder. Something took Marty off his course. He seemed to be riding the radio beam and reporting in regularly. He had plenty of altitude according to his reports."

"Yet he stuck his nose in the side of a mountain," Bill said, bitterly. "It doesn't make sense." He whirled and pointed at the long log cabin that stood on the edge of the flying field. "Anybody in that place over there?" he asked.

"It's unoccupied right now," Longnecker said. "It belongs to Hank Fawcett. He uses this place up here as a hunting lodge. I have a key if you want to get in."

"That's what I want to do," Bill said. "I want to get in there and get some sleep before I drop over. I've only had about three hours' sleep in two nights."

"That's easy," Longnecker said. "What do you want me to do while you're sleeping?"

"Take Sandy back with you and load up two of your ships with fuel and bring it back to me. It won't do to land the Lancer any place, but I've got to have her loaded with all the fuel she'll lift. Once I get in the air again I'll have to stay there. I won't dare land. I want to search the ground leading out of Summit along Amalgamated's air courses."

"You have an idea, Bill?" Longnecker asked.

"Yes," Bill said, shortly.

"You'll need help to do that. This is wild country."

"I'm going to send for help," Bill said. "I may cut my own throat by doing it, but I'm going to get my field and tell my radio man to send Shorty Hassfurther and Red Gleason here. They can make it in six hours."

"Won't the police be able to pick up the call, too?"

"Probably," Bill said.

"What about Burt putting through the call from Denver?" Sandy asked.

"That's it!" Bill snapped. "Do you think you can make Shorty understand what you mean without letting the police know what you're talking about?"

"I can try," Burt said. "Shorty's a pretty smart guy."

"Sometimes," Sandy said.

Burt Longnecker grinned. It was common knowledge along the airways of the country that young Sandy constantly took a terrible ragging from Shorty Hassfurther and Red Gleason.

"Shut up," Bill said to him. "What's that thing under your arm?"

"My camera," Sandy said. "I'm going to try to get those plates developed while Burt is having a couple of ships loaded with fuel."

"Listen," Bill shouted, "you forget

your camera and stay on the job! Is that clear?"

"Yes, sir," Sandy said, but he kept the camera under his arm.

"Just make Shorty understand that I want him and Red to come to Denver. Tell him to keep in touch with you so you can lead them here. Is that all right with you?"

"That's O. K.," Longnecker said. "They'll probably be arriving out here about the time we'll be coming back. It's going to take me a little time to get satisfactory fuel for your Diesels. I'll have to test it."

"Where's that key? I'm asleep on my feet. Bring me back some food, kid. The Lancer will be all right here?" Bill asked Longnecker.

"She ought to be. No one ever uses this field. Very few people even know about it. You may find some food in the house, Bill. But we'll bring some back to you. You need all the sleep you can get. You look like hell!"

Twenty minutes later Bill was stretched out on a couch in the beamed living room of the log lodge. He was too tired to even look for food. He pulled a blanket over himself and fell asleep immediately, exhausted.

## IX—SANDY'S DISCOVERY

THAT WAS the way Shorty, Red, Sandy and Burt Longnecker found him seven hours later. He did not hear them come in for a landing. He woke up when Sandy shook him and stuck a thermos bottle of coffee under his nose.

"You never killed any one if you can sleep like that," Burt Longnecker said.

Bill didn't answer. He couldn't. His mouth was too full of food. He ate like a man who had not eaten in days instead of hours. He refused to talk until he had consumed all the food and all the coffee they had brought him.

"Look at these, Bill," Sandy said to him. He held three 4x6 prints in his hand. Bill pushed him away, impatiently.

"They're the best pictures I ever got," Sandy insisted. "Look at the detail in them. Look—"

"Look at 'em yourself!" Bill said. "Don't bother me with that stuff. I want to talk to Shorty and Red when I finish this food. Thanks for bringing it, kid. It's the best food I ever ate."

"And these are the best pictures you ever saw," Sandy went on. "They're so—"

"It sounds to me as though he bought himself a camera," Shorty said to Red. They both grinned.

"Yeah," Red said. "The first thing you know he'll hear about the movies." He turned to Sandy. "Did uh 'iddle boy take a big, big picture wiv his 'iddle camera?" he asked.

"Nuts to you, smart guy!" Sandy said. "Listen, Bill, I want you to look at these because there is something funny on them. You remember after you saw Siebert in Washington yesterday you told me you thought perhaps Marty Dewart's crash was caused by a bootleg radio beacon? Well, I think I can see a radio antenna in these pictures. It's——"

"Why in hell didn't you say so be-

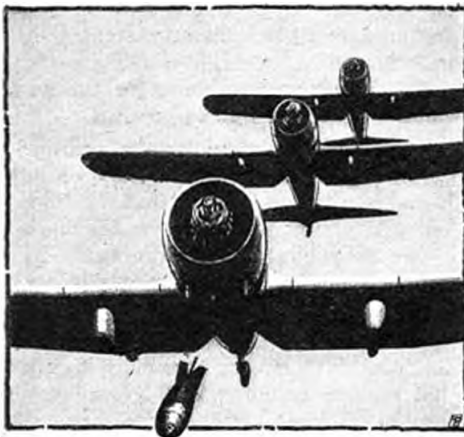

The monoplanes were diving out of the heavens in a stepped-up column formation—short, squat projectiles hurtling from their bellies——

fore?" Bill roared at him and grabbed for the pictures.

"You didn't give me a chance." Sandy said. "I——"

"Shut up," Bill said, "and show me!"

"My gosh," Sandy said. "Look." He pointed at a pair of radio masts that reared their heads high above the surrounding trees.

"Look here, Burt," Bill said, and his voice was charged with excitement. "Is there a broadcasting station or radio beacon out in that wilderness?" He told Longnecker as closely as he could where Sandy had taken the pictures.

"No," Longnecker said. "That is, I didn't know there was one there. But it's clear enough in those pictures."

"It's the one I was going out to look for," Bill said. "I'll bet my shirt on it. It's the place that sent out the fake beam that sent Marty Dewart and his passengers to death!"

"What do you mean, Bill?" Shorty asked. "What's on your mind? You sound a little goofy to me."

"All right," Bill said, "I'm goofy. Now listen. Some one caused those four crashes on the Amalgamated lines because they wanted to run 'em out of business or buy 'em out cheap. They established that beam, a bootleg beam built out in the wilderness, so that they could lead Amalgamated ships off their course and cause them to stick their nose into a mountain. They also tampered with Marty's altimeter and his turn-and-bank indicator.

"At about the same time they smeared acid or something else on the control cables of Jerry Winsor's ship. They put a bottle of whisky in the pilot's compartment, where it would break when the plane crashed and make it look bad for Jerry."

"Who do you mean by 'they,' Bill?" Shorty asked.

"Monkey Worts was doing the dirty work until he talked too much," Bill said. "But Monkey was just the strong-arm guy. There is big money and power behind the thing. They had enough power to influence the police commissioner, or he wouldn't have tried to hold me. The same methods have been used in every other business by unscrupulous operators."

"All right, Bill," Burt Longnecker said. "What's the next move?"

"We're going to locate that station first," Bill said. "Then we're going to find some way to get in there and take it apart. If we don't there will be more crashes and more lives sacrificed. You've read the rumors in the aviation magazines about the mysterious combine of companies that will span the continent and both the oceans?"

Burt Longnecker nodded his head.

"It may be the men behind that combine that are behind this thing. If they are, transatlantic and transpacific planes will begin to disappear. That's what I'm afraid of. Once they start they'll keep on until they complete their horrible scheme. They'll form a powerful round-the-world chain of airways that will be built on the lives of innocent men and women. They'll strike again and again, until the airways are at a low ebb and people are afraid to travel on them. Then they'll gobble 'em up."

"I'm afraid you're letting your imagination run away with you, Bill," Longnecker said.

Bill glared at him, his face crimson. "That's the trouble with you birds on the air lines," he said. "You're too well satisfied with yourselves. Instead of anticipating things you sit on your thumbs until things begin to go wrong. Then you begin to cry."

"But, Bill——" Shorty began.

"But, nothing!" Bill growled. "Let's snap out of it and get that fuel into the Lancer. We have something to do besides twiddle our thumbs." He stamped angrily out of the house.

The others followed him silently.

When the fuel had been transferred from the two Amalgamated transports to the tanks of the Silver Lancer Bill kicked over the twin Diesels in the nose and began to warm up the engines.

"What about getting these two ships back to your field?" Bill shouted at Longnecker.

"I'll take one of them back," Longnecker said, "and send a couple of pilots over to get the other one, if you need Sandy with you."

"That would be best if you can manage it that way," Bill said. "I can't land at Denver to pick him up without taking a chance on being arrested. If Shorty or Red land there it will be a give-away that I'm close by. I'll keep in touch with you, Burt, and let you know what develops. I may need help."

"I'll be ready any time you want me, Bill," Longnecker said. They shook hands. Bill was about to say something about his flare-up of a few minutes before, when Sandy drove all thought of it out of his head. He saw Red and Shorty dive into their Snorters as Sandy came running toward him pointing back and up over his shoulder. He couldn't hear what he was saying because of the roar of his motors. But he didn't have to hear.

He saw the flash of the sun on the silver, low-winged monoplanes that were diving out of the heavens in a stepped-up column formation. He saw the twenty-five-pound bombs that nestled in their racks underneath their bellies and the two fixed machine guns on their wings. He knew that within a few seconds they would lay those eggs that nestled beneath them and rake the ground with a storm of machine-gun bullets that nothing could withstand.

He saw Red and Shorty pour soup into their Snorters and blast them into the air as Sandy dived into the rear cockpit of the Lancer. He made a downward motion with his left hand toward Burt Longnecker, as he released his wheel brakes with his right. He saw Longnecker throw himself flat on the ground as the two great props on the Lancer became shimmering disks.

His heart climbed up into his throat as the big ship seemed to inch forward at a snail's pace. He saw Shorty and Red streak into the air, as the first of that stepped-up column nosed up while the gunner released a bomb. He saw the short, squat projectile come hurtling toward the Lancer for a direct hit. His mouth became a savage slash across his face as he wheeled around into the wind at terrific speed, giving the rudder such a vicious kick it slapped against the stop as he poured juice into the engines to blast the tail around.

The left wheel skidded on the inside turn as he jammed the brake and the Silver Lancer pivoted and pointed her nose into the wind. He felt the Lancer's nose rise and then plunge sickeningly back toward the ground as that first bomb detonated. He pulled the stick back and waited for the crash. But the two powerful Diesels in the big ship screamed their protest as the props dug into the air. The landing wheels just kissed the ground and bounced into the air again.

Bill poured in the soup, hung the Lancer on the two props and took it into the air in an almost vertical climb as the

ground became an inferno of exploding bombs and chattering machine guns.

He looked back and down and saw that the two Amalgamated transports had been blown to bits. He saw no sign of Burt Longnecker. A blistering curse escaped his lips as he scanned the air for Red and Shorty. He saw them thundering down on the eight low-winged monoplanes as they zoomed upward after dropping their cargo of destruction.

"Swing out that swivel gun, kid!" he roared in the intercockpit phone to Sandy. "There is a gunner in every one of those planes and they don't intend to let us get away from here alive."

"O. K., Bill," Sandy said and the calm steadiness of his voice quieted Bill's screaming nerves. "Bounce the tail around each time as we go by so I can get a shot at them. Five of 'em are forming a V and are trying to climb up on our tail. Shorty and Red are teaching the other three tricks."

As Bill leveled the Lancer off he saw Shorty come out of his steep dive and level off in an inverted position. One of the silver monoplanes was directly in his path as he centered his controls and clamped his finger down on his electric trigger. Fire and smoke gushed out of the nose of the Snorter's powerful .50-caliber guns and drove into the tail of the silver ship.

As the ship skidded off to the right Shorty half rolled the Snorter upright. The pilot of the low-winged monoplane looked back and up over his shoulder, as Shorty got him under his telescopic sights again. The strained whiteness of his face became a crimson mask of blood as Shorty's bullets tore into him. The silver ship nosed up until it seemed to be dancing on its tail. Then the nose dropped and it began a dizzy, swirling descent to earth.

Sandy's freckled face was dripping with perspiration as he ran his .30-caliber gun across its track and tried to take a sight on the five monoplanes spiraling upward. He heard the first *tat-tat-tat* of their machine guns and could feel their bullets lashing through the tail assembly behind him. Then he felt the nose of the Lancer come up, as Bill pulled the stick back into his stomach and sent it skyward in a desperate zoom.

"All right, kid. Let's take 'em!" Bill called back to him through clenched teeth. The five monoplanes had broken their formation and were coming at him from every direction, tightening a circle around him.

Bill stuck the nose of the Lancer down and gunned the engines to get out of the vortex of their fire. Then he chandelled up and back and tore into them with the wild fury and abandon of a man gone mad. The five ships skidded and slipped and zoomed to get

out of his flaming path. Bill's fingers were fastened down hard on his gun trips. He raked a silver monoplane with a withering fire and saw the pilot lunge forward on the cowling as though he was going to dive over the side.

He gunned his engines again and came over in a normal loop on the tail of another ship. His line of tracer smoke curled harmlessly above the head of the pilot until he corrected his aim. Then his bullets crashed into the fuselage and crept forward into the engine block. Little wisps of smoke rose along the engine housing.

As he zoomed upward again he heard Sandy's swivel gun chattering like an angry magpie. He glanced over his shoulder. Sweat was running down the kid's face. It was smeared with streaks of black. His eyes were gleaming as he sighted along the smoking barrel of his gun.

Then the air seemed choked with slashing, flashing silver monoplanes. They were like angry hornets as they circled around and around, waiting for a chance to dart in and write death across Bill's name. They were everywhere, charging in and then retreating, their guns vomiting lead.

Bill took the Lancer through the sky with the speed and fury of a flaming meteor, trying to escape that lead. He saw his own bullets cut through the enemy planes a half dozen times, as he got them under his hair sights for a single burst. His aim was deadly, in spite of the terrific speed of his maneuvers.

Now and again he could feel the Lancer shudder in protest as enemy bullets drove through it. But he fought on, his lined face tense and terrible in its absolute concentration. He whipped the Lancer up and down, skidded and side-slipped, zoomed and dived, to avoid the worst of the streams of lead that were aimed at him. His breath was coming in quick, agonized gasps now. His hand was wrapped around the control column like a band of steel. He used his guns only when he had a ship dead under his sights. He was using all of his natural ability and instinct to outguess and outmaneuver the three ships who charged at him so desperately.

Suddenly, he zoomed upward and reversed his direction, while he probed the air around him to find Shorty and Red. They were each engaged with a single ship and had drifted far off to the left. He saw that they were fighting for their very lives, against men who were more than skilled air fighters. He fed juice to his engines to join them, as the three monoplanes crept up on his tail again.

In another minute the skies above that barren waste of mountains became a thundering, snarling madhouse of flaming guns and roaring motors. Sandy had lost his calmness now and was shout-

ing as he poured burst after burst at the wheeling, circling monoplanes. It was the maddest, wildest fight he had ever been in. His face was flushed and streaked with smoke and dirt and his eyes were gleaming wildly. Planes whipped and rolled around him like feathers in a hurricane. It was a desperate duel to the death with five against three.

Shorty Hassfurther lost the man with whom he had been fighting and singled out another silver monoplane as Bill flashed above him. In an instant they were locked in a terrific death grapple, each feinting and stabbing for the advantage that would mean survival.

Then, Shorty got under the whirling silver ship. He raked the belly of its fuselage with one long burst of lead. The pilot writhed up and over the cowling as the rugged little fighter began its death spin to the desolate wastes below.

Red Gleason darted after the silver ship that tried to flee from the inevitable death in his guns. He tore after it with that reckless abandon that was characteristic of him. His fingers clamped down on his gun trips as the plane came under his sights for that fleeting instant that is the difference between life and death. White streamers and lead pumped into the fleeing ship. It rolled off on one wing; the nose dropped; flames began to lick backward, fanned by the gale that raced with it. The pilot shot out of the cockpit, turned slowly over and over, as though he was waiting until he was away from the fight before he ripped his parachute. But he never used his parachute. His body plunged into the earth only a few feet away from his blazing ship.

Red came over in a half snap roll and returned to the fight. A half minute later he brought his Snorter around in a flashing Immelmann, as two ships charged toward him. He drew a pencil line along the fuselage of one of them as he half rolled his ship back to a level position. The silver ship wobbled and yawed wildly, and Red followed it with grim tenacity as it spun toward the ground.

Sandy's cry of warning was all that saved Bill Barnes' life as the last of the little silver bullets dived on him from above, with its guns belching fire and lead. Bill skidded the Lancer out of the way as the monoplane roared over him. As it came out of its dive he pounced on it with all his fury. He saw the white, contorted face of the pilot as he looked back and up over his shoulder. Then Bill's powerful .50-caliber bullets pounded into the silver ship. It quivered and lurched like a mortally wounded animal and then plunged to its destruction.

Bill knew that the speed and maneuverability of the Silver Lancer alone had saved them. As Shorty and Red flashed

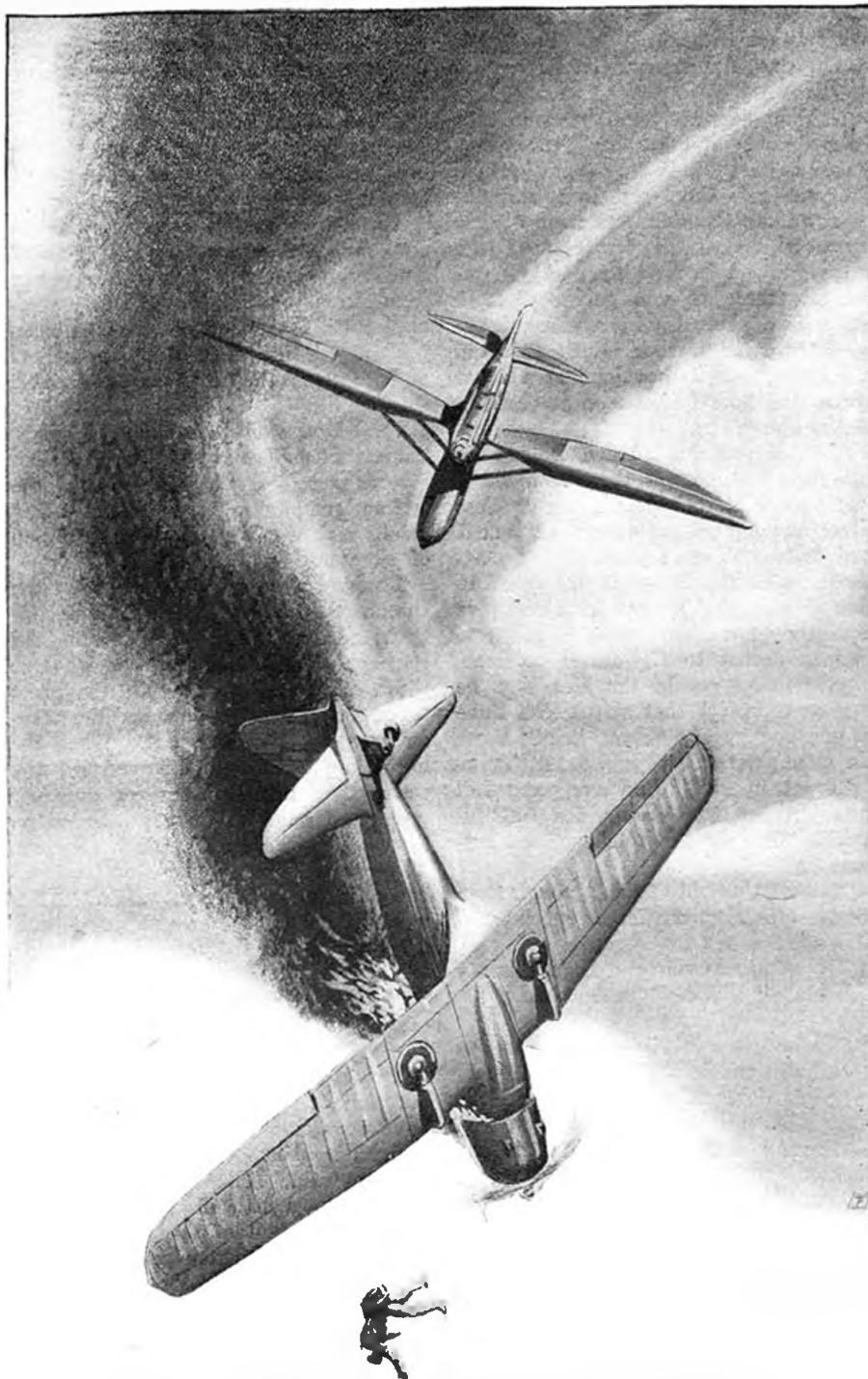

The ship rolled off on one wing; the nose dropped; flames began to lick backward. The pilot shot out of the cockpit, rolled over and over—

above him he threw the switch on his radio panel and shouted into the microphone.

"Cruise around here for a bit," he said, "and see if any of those pilots or gunners are still alive. I'm going down to see what happened to Burt."

#### X—A MESSAGE INTERCEPTED

BILL BARNES ran a hand across his flushed face while he spoke to young Sandy. "You're all right, kid?" he asked.

"Gosh, I'm dizzy, Bill," Sandy said.

"That was the fastest fighting I ever saw. Who were they?"

"You tell me, kid," Bill said. "The people who are trying to grab Amalgamated want us out of the way so they can commit a few more murders. Hold everything now. I'm going to land. The field is blown full of craters, but I think I can make it."

He kicked the Lancer around into the wind and fishtailed it in to reduce his speed. It did not seem possible that he could avoid all of the yawning holes that had been blown in the ground by the bombs of those eight silver mono-

planes. But avoid them he did, with his uncanny skill.

As he locked his wheel brakes near what had been the hangar he saw something stir in the center of the debris. He climbed wearily over the side of the Lancer as the stir became a small volcano and Burt Longnecker came to view. His clothes were half torn from him and his face and hands were clotted with dry blood. Bill rushed to his side and saw that he was still dazed.

Bill shouted to Sandy, "Make contact with Red and tell him to make a landing and take Burt back to Denver. He needs a doctor."

"I'm all right, Bill," Longnecker said. "I tried to get inside the hangar and when I did it collapsed. I'm just scratched and bruised. You know too much, Bill. Some one is gunning for you again."

"Hell is going to pop, Burt," Bill said. "I've got to get in the air and get in touch with that radio beacon. If I can't pick up their messages I've got to get in there. They wanted me out of the way badly enough to send those planes after me. That means they are going to strike again. I've got to stop them!"

"Here comes Red," Burt said. "I hope he makes it."

"He'll make it," Bill answered. But his forehead was creased with worry as he watched Red bring his Snorter in. For one awful second he saw the port landing wheel on the Snorter sag into a hole. Then he saw the right wing drop and both wheels were back on solid ground.

He helped Longnecker into the rear cockpit of Red's Snorter and gave him instructions. "We'll be riding above you. I want you to join us after you drop Burt," he said. "We'll be cruising some place east of Denver. You can pick us up."

"O. K.," Red said. He took Snorter off the ground in a low climb.

Both Bill and Shorty worked over the calibrated dial of the master tuning control of their radio receiving sets until their nerves were screaming from fatigue. They tuned in and out with their volume and wave-length controls until it seemed their task was a hopeless one.

Finally, Bill said to Sandy, "I'll take the controls, kid. You work over the radio. I'm getting jittery from trying to tune the thing."

"O. K.," Sandy said, and he began the nerve-racking job of turning the dials an infinitesimal fraction of a second at a time to catch the faintest click that he might bring in with his volume control.

Twenty minutes later he threw the radio tumbler and the intercockpit phone switch and said, "I have a sta-

tion close-by that is speaking French, Bill."

"Probably a Canadian station," Bill said, but he threw his radio switch and listened.

Suddenly his whole body stiffened and he spun the dials and chanted Shorty's name into the microphone. When Shorty answered he said, "Quick, Shorty, tune your radio in on"—he gave him the frequency in fractions—"and see if you can translate that conversation in French."

He spun his own dials back to the same frequency and listened. Here and there, as he listened, he picked up a word he understood that brought a new gleam to his tired eyes.

Then, the gleam turned to one of incredulous wonder as it dawned on him that he recognized the voice of the man who was giving instructions from an Eastern short-wave station. At first he doubted his own ears, but as he studied the inflections and diction of the voice he was certain.

His thoughts raced back, forming a chain in which the links fitted one after another. He was cursing softly to himself when the two voices signed off and Shorty's voice came back to him.

"You were right, Bill!" Shorty said, excitedly. "That was a conversation between a short-wave station some place around New York and that station Sandy got in his picture."

"And what?" Bill asked.

"We've got to move fast," Shorty said. "The voice from New York laid all the cards on the table. They are sending six of those silver monoplanes to intercept the transatlantic mail and passenger plane that leaves Boston for Harbor Grace this evening. They are to shoot down the plane and make sure that all the evidence goes to the bottom of the Atlantic!"

"You're sure, Shorty?" Bill asked as anxiously as he could.

"Yes," Shorty said, "I may have picked up my French in some strange places, but it works! And that isn't all!"

Bill listened incredulously while Shorty told him the rest of the conversation. His blood ran cold as he listened to the diabolical scheme Shorty unfolded. Then his face became a thundercloud as he broke in on Shorty.

"Wait until I pick up Red," he said. He spun his dials and chanted Red's call letters into the microphone. A few seconds later Red answered.

"Where are you, Red?" Bill asked.

"I just left Denver, heading your way," Red said. "Where do I pick you up?"

"You don't pick us up," Bill said. "Do you have enough fuel to take you back to Barnes Field?"

"Plenty."

"All right," Bill snapped. "Now lis-

ten, and don't ask me a lot of questions when I get through, fella. I'm going to tell you all I know. Get it?"

"Shoot it!"

"I want you to pour the soup into your Snorter and get back to Barnes Field as fast as you can and refuel. On your way there get Tony and tell him to have Cy and Henderson on the apron with their Snorters ready to go when you get in. As soon as you refuel all three of you get to Boston. There is a plane leaving the municipal field there for Harbor Grace at seven o'clock. It lays overnight at Harbor Grace and hops for London at dawn in the morning.

"But if you don't reach Boston by the time it takes off there to-night it won't reach Harbor Grace. Six of those silver monoplanes are going to attack it and destroy it some place over the Atlantic to-night. I want you three to ride above it and protect it. Don't give out any word about what is going to happen except to Cy and Henderson, after you all get in the air. But be sure you protect that ship. The three of you ought to be able to handle those six monoplanes. Do you get it?"

"I get it, Bill," Red said, and Bill marveled at the steady tone of his voice. "You want us to shoot their buttons off!"

"I want that ship to go through from Boston to Harbor Grace untouched," Bill said.

"What about you and that Monkey Worts thing, Bill?" Red asked. "Is Shorty—"

"We've got a job to take care of out here," Bill cut in. "Give her the gun!"

"She's doing three fifty now!" Red snapped. "I'll be seein' you."

"Signing off!" Bill said. "Good luck!"

## XI—ATTACK

THE twenty-five-ton flying boat, the *Manila Packet*, of the Transpacific Airways, lay moored against the landing ramp at Alameda Airport. The orange wings of the giant ship gleamed brightly in the rays of the late-afternoon sun. The hull was down to the black water line with twenty passengers, a crew of seven and a heavy load of mail aboard. The operations manager was giving last-minute weather reports to the skipper on the bridge, as the big *Packet* made ready to loose her moorings.

The outboard one thousand h. p. motor on the port wing coughed itself to life. A moment later the outboard motor on the starboard wing spluttered into action. A crash launch sped away from the dock to the right of the course the fifty-thousand-pound ship would take. The two remaining motors came to life in their nacelles in the high wings. The big boat eased slowly away from the ramp and the whine of her motors

rose to a scream. White spume sprayed up from each side of the hull like the dancing waters in a garden fountain.

The great hull lifted slowly, until only the tail surfaces were in the water. The two fountains vanished and the big boat was in the air on its twenty-four-hundred-mile trip to Hawaii.

The skipper took the ship upward in an ever-widening circle. The city of San Francisco faded away in the ground haze that hung over it. The four powerful motors sang as one, as the skipper altered the pitch of the propellers and adjusted the throttles to cruising speed.

Point Bonita flashed under the wings, the last sight of land until the Hawaiian Islands were sighted. The rays of the setting sun broke through the wispy clouds and the big ship became a ball of silver-and-orange fire.

Twelve thousand feet above the speeding *Manila Packet*, and twenty thousand feet above the Pacific, Bill Barnes and Shorty Hassfurter cut their throttles to keep pace with the giant transport. They had watched the take-off from ten thousand feet. When the big flying boat had skimmed off the water they hung their ships on their props and went upstairs and turned on the oxygen in their sealed cockpits. They were probing the sky like two hawks in the gathering twilight. They were in constant communication with one another over the radiophone. Sandy was asleep.

"I forgot to tell you, Bill," Shorty said, "that during that conversation in French the man at the station in Colorado told New York that they had sent out planes to get you and they wouldn't have to worry about your interfering with their plans."

"I'm afraid," Bill said, dryly, "they're going to be a little disappointed."

The great ball of fire that was the sun seemed to brighten perceptibly just before it plunged into the Pacific. The world became a place of rich purples, with little turrets of gold topping the spires of white clouds on the horizon. Then, the purples turned to gun metal and black in the east and night was upon them.

"We'd better drop down about eight thousand feet," Bill said, and his voice was tense. "When they strike they'll come from nowhere."

"Navigating lights?" Shorty asked.

"No lights," Bill said, sharply. "It will be almost as light as day in a few minutes. That moon is almost full and the clouds are drifting away from it. I wonder—" he broke off abruptly.

"Wonder what?" Shorty asked. He had detected a note of anxiety in Bill's voice.

"Nothing much," Bill said. "It just occurred to me that perhaps we should have warned the navy base at San Diego

to stand by. If we fail it's going to be too bad for the twenty-seven people aboard the *Packet*."

"We don't fail, fella," Shorty said, in a tone that brought a grin to Bill's lips. "Clouds are closing in beneath us."

Below them the red-and-green flying lights gleamed on the tips of the big ship's wings. And farther below a moon bow, or luminous ring, encircled the shadow of the ship on the clouds. The moon seemed to be riding directly on the tail of the transport, and its rays reflected back from the clouds gave the night a soft, silvery light. As a hole opened in the clouds for a moment the black waters of the Pacific gleamed far below.

"I think," Bill said, "I'll get through to the navy. It's too big a responsibility, for us to take. If anything goes wrong it will be our fault. We'll be blamed. We—"

"It's too late now!" Shorty screamed into his microphone. "They're coming! I can see their lights! They're about two points off the starboard bow of the *Packet* and five thousand feet up. They're diving!"

"Cut 'em off!" Bill roared and he poured juice into the twin Diesels of the *Lancer* until they screamed in protest. "Get in low, come up under 'em and break their formation before they have a chance to use their guns."

The *Silver Lancer* left Shorty's Snorter almost sitting still in the air, as it raced above the big flying boat and Bill stuck the nose upward. He could hear the screaming whine of the six power plants in the noses of those six diving ships. He snapped on the running lights on the tips of his own wings, so that they would not drive through him on their way to pour their lead into the transport. He shouted to Shorty to do the same.

But the six diving ships did not pull up. They held their formation while they screamed out of the night at four hundred miles an hour. Cold perspira-

tion crept out all over Bill Barnes' body as he saw those six Juggernauts of death racing down on him. In that fleeting second he died a thousand deaths.

It flashed through his mind that he should not have taken the responsibility for those twenty-seven lives in the *Manila Packet*. He would die and Shorty would die, and all of those twenty-seven would go to a watery grave with the pilots of the silver monoplanes that crashed into him.

The green-and-red lights on their wing tips grew as large as the head of a searchlight as they dived on him. It was all happening so fast that his eyes could not keep up with it.

Then, his eye glued itself against the telescopic sight before him for a fraction of a second, as his hand tightened on the electric gun trip set in the handle of the control column.

Six times the 37mm automatic engine cannon poured high-explosive shells and orange flame through its barrel in the hollow crank shaft. Three of those deadly shells found their mark, as they drove into the power plant of the leader of the diving planes.

A great cloud of black smoke welled up where the little monoplane had been. Then, great streaks of orange and saffron flame shot out of it as the gas tanks exploded. Debris flew in every direction and the remaining five planes zoomed in five different directions to escape.

Sandy, in the rear cockpit, swung his swivel gun in an arc and poured machine-gun bullets after the zooming ships.

Bill spun the dials on his radio until he had the call frequency of the *Manila Packet*.

"Calling WOOM aboard *Manila Packet*. . . . Calling WOOM aboard *Manila Packet!*" he chanted. "Hold your course; you are being attacked," he instructed. "Hold your course; there is no danger. Will report after we have driven off attackers."

He threw the radio key and probed

the air above him. He saw that Shorty was tumbling through the air, engaged with one of the enemy ships. Bill could hear the powerful *tat-tat-tat* of his .50-caliber guns.

Then he saw flame racing out of the exhaust pipes of the other four ships as they dived on him from four sides. The noses of the four ships belched fire and lead as their machine guns converged on the *Lancer*.

Bill's face was twisted as he yanked the control stick of the *Lancer* back into his stomach and opened the throttles. He knew that he would have to take less punishment if he went into the face of their converged fire than he would diving away from it. He could feel the *Lancer* quiver and buck as bullets drilled through its surface. Splinters ripped his face as bullets drove into his instrument panel and thudded all around him.

He threw a quick glance over his shoulder as the planes flashed by him, and he heard Sandy's guns yammering again. The kid's face was glued against his guns as he poured round after round at the four diving ships.

As they came out of their dive and zoomed back to the attack, Bill brought the *Lancer* around in a steep bank and stuck the nose on the leading monoplane. His eyes picked the ship out clearly through his infra-red ray telescope.

The air churned with flame and smoke and bullets, as he dived the *Lancer* like a plunging gannet. Bullets drove up through his wings and the folded amphibian gear as he clamped down on his guns. His bullets ripped into the nose of the oncoming plane and crept back to the windshield, to tear away the face of the pilot behind it. The ship zoomed upward as it went out of control, and Bill dived beneath it, clearing it by inches.

He heard the chatter of Shorty's powerful guns again and probed the sky overhead. He saw Shorty follow-

## AIR TRAILS ANNOUNCES

# Another Championship Model IN NEXT MONTH'S ISSUE

## The STOUT TROPHY WINNER

This is an OUTDOOR FUSELAGE ship you will want to build  
Articles and plans prepared in collaboration by ERVIN LESHNER and GORDON S. LIGHT

DON'T MISS THIS EXCLUSIVE SERIES OF CHAMPIONSHIP PLANS

Be Sure to get the MAY issue of AIR TRAILS



ing a ship toward the cloud bank below, pouring round after round of bullets into it.

Far off to the west he saw the giant *Manila Packet* silhouetted against the moon, as it sped away on its course. He knew the radio operator aboard her had picked up his message.

He poured juice into the Lancer and chandelled back to the attack, as two of the remaining planes tried to break away and start after the speeding *Packet*. The Lancer raced through the night with its exhaust pipes glowing and spitting fire. As the two ships ahead of him realized that they could not match his speed they zoomed upward to get away from the deadly accuracy of his guns. One of them swept off to the right in a steep, climbing turn, the other to the left.

Bill stayed on the tail of the one that cut to the left. Again his fingers clamped down on his gun trips. He saw his tracer smoke curl above the head of the pilot of the silver monoplane. He corrected his aim and knew that his bullets were tearing into the tail surfaces. As the plane came farther around he again corrected his aim and drew a line the length of the fuselage.

The silver ship fell off on its right wing; the nose dropped and it began a sickening spin toward the dark waters below. Bill watched it until it disappeared through the cloud bank, then searched the night sky for the other monoplane.

"He's had enough, Bill," Sandy said in his ear. "He has peeled off and is going home to get his feet warm." Then Sandy's voice rose to a high-pitched squeal. "But, Bill, while Shorty was finishing off one ship another dived on him. Something's wrong with him, Bill. He's staggering. His ship is out of control! It's on fire, Bill! He's dropping through the clouds!"

Bill caught just a glimpse of Shorty's rudder as it whirled into the clouds and disappeared. He brought the Lancer around on a wing tip and dived for the hole where Shorty had disappeared. When he came out below the cloud bank the night was as dark as the inside of a dungeon, except for the light cast by Shorty's Snorter as it plunged toward the Pacific.

Bill's whole body was trembling and he was bathed in cold perspiration as his lips mumbled incoherent curses at the pilots of those silver monoplanes.

"Has Shorty bailed out? Can you see him?" he shouted to Sandy.

"I think he's still in his Snorter," Sandy said and there was anguish in his voice. "No, Bill!" Sandy screamed. "He's climbing over the cowling now. He's struggling to push himself up. There goes a flare."

They saw a parachute flare shoot out of the spinning Snorter, and then they

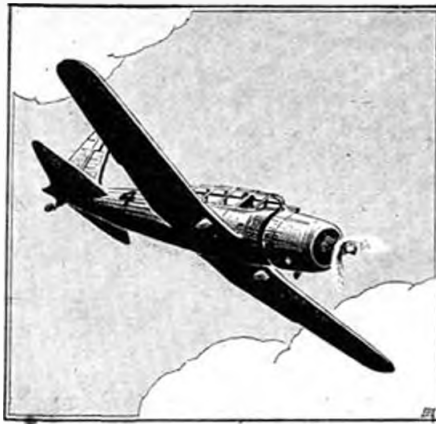

Bill banked the Lancer around, put it back on its course and opened the throttles—

saw Shorty's form follow it, turning over and over as he fell.

Bill's hand froze around the control column of the Lancer as he circled it down. His throat was dry and contracted so that he could not breathe as he saw Shorty falling closer and closer to the waters of the Pacific.

Then, his breath came out of his body in one great gasp as the pilot's chute from Shorty's seat pack streaked out behind him, followed by his main chute. A little murmur, that might have been a prayer, escaped his lips as he guided the Lancer to a landing as close to Shorty as he could manage.

"Get out on the wing, kid," Bill said. "Be ready to grab him. He'll be all tangled up in his parachute."

Sandy went out on the wing like a human fly, as the Lancer bumped along over the huge swells. Bill kicked his rudder, cut his throttle and spun the Lancer around so that Sandy could grab the end of Shorty's floating chute. He pulled him up to the wing, hand over hand, and helped him struggle out of his harness. With Sandy's help he got one knee up on the wing, then his body. They squirmed back toward the fuselage, while Bill held the big ship as steady as he could.

"You're not wounded, Shorty?" Bill asked when they were both in the after cockpit.

"Who ever saw a wounded Hass-further?" Shorty wanted to know. "I had just shot the warts off one pilot's nose when another jumped me. He got me plenty. My Snorter was out of control and he must have been loaded up with incendiary bullets. I couldn't get out of the cockpit because of the spin. Centrifugal force held me in. I managed to get halfway out and shoot a flare so you could see to pick me up."

"That's that," Bill said. He flipped his radio switch and tuned in on the frequency of the *Manila Packet*.

"All clear, WOOM," he said. "This is Bill Barnes speaking. You'll have no further trouble. I'll make a report to

Alameda and your home office. Signing off. Good luck."

That was all.

## XII—REPORTS

A HALF HOUR LATER Bill managed to make contact with Tony Lamport on Barnes Field, Long Island. He breathed a sigh of relief as he listened to Tony's report.

"Had a report from Red, Cy and Henderson some time ago," Tony said. "We were getting worried about you, Bill."

"All right," Bill said, "here I am! What did they report?"

"Oh!" Tony said. "They escorted the plane all the way from Boston to Harbor Grace. They sighted a formation of six planes. But the six planes didn't attack after they saw the three Snorters. They turned tail and disappeared."

"Good," Bill grunted. "Is Commissioner Barton still camping around there?"

"No," Tony said, "but his men are. The place is filled with them. There is one here beside me. He wants to arrest you by radio!"

"Tell him to save his breath," Bill answered. "Get in touch with Barton and tell him the power behind the throne is responsible for the mugger of Monkey Worts, those pilots and passengers. Tell him he'd better take him into custody before he commits suicide. Tell him I can prove he's guilty."

"Who's guilty, Bill?" Tony asked. "You haven't told me who you're talking about."

"Benjamin Shipman, chairman of the board of directors of Amalgamated Airways and chairman of a lot of other things," Bill said wearily. "He's the power behind the throne. Tell Barton to slip up behind him and locate the short-wave station from which Shipman has been broadcasting. Then he'll have him cold. Tell Barton I heard him broadcasting and recognized his voice. Then all the links fitted the chain. He was trying to grab Amalgamated, Transpacific and Atlantic Airways and form an around-the-world air chain. He's one of the robber barons you've read about. Do you get it?"

"I get it, Bill," Tony said. "It's hard to believe."

"Don't try to believe it," Bill said. "Tell Barton I can prove it."

"What are you going to do now, Bill?" Tony asked.

"We're going to drop off in Denver to see if Burt Longnecker is O. K.," Bill answered.

"Then what?" Tony asked.

"We're going to bed!" Sandy shouted into the microphone.

"And, Tony," Bill said, "order a flock of plates for Sandy's new camera. Tell Barton to put 'em on his swindle sheet. Signing off!"

# GETTING INTO AVIATION

(Continued from page 19)

are getting free flight training without being required to have any college education at all.

For some time the navy has been sending enlisted men to Pensacola to be trained for the rating of "naval aviation pilot." (Officers and naval reserve aviation cadets are given the rating of "naval aviator.") Recently, the navy increased the number of enlisted men being trained to fly. On August 11, 1936, the bureau of navigation sent out a call to "all ships and stations" directing commanding officers to recommend all men who met certain requirements. As a result, fifty enlisted men per month are being sent to Pensacola the last four months of this fiscal year (which ends June 30th). It is most probable that a number of men will be sent every year. It was the private opinion of an officer in the navy department at Washington that the number would be considerably increased next year. Beyond that nobody guesses.

The chief trouble with this road to Pensacola is that it is a long one, with many chances of being sidetracked. But if you are a young man above the average in quick, practical intelligence, if you have finished high school with a pretty good record, and if you can pass a flight physical examination, your chances are not at all bad. A medical examiner for the bureau of aeronautics of the department of commerce can tell you if you are likely to fail the physical examination.

All right. Suppose you decide you would like to be a naval aviation pilot. The first step would be to join the navy. For first enlistment you must be a male, unmarried citizen of the United States between seventeen and twenty-five years old, at least sixty-three inches in height if under eighteen, or sixty-four if over eighteen. You must pass a fairly rigid

physical examination (which is nothing if you can pass a flight physical), a fairly easy intelligence test, and give a list of former employers or teachers, or references from two responsible persons. If you are under twenty-one you must secure written consent of parent or guardian. No specific educational requirement is stated, but there have been so many applicants to pick from that the recruiting officers have been taking practically nobody except boys with high-school education. With more civilian jobs opening up these days, however, that may change.

Application should be made to the nearest navy recruiting station. If you don't know where one is, write for information to the Navy Department, Washington, D. C.

The two hundred enlisted men being trained at Pensacola this fiscal year were selected from among men with aviation ratings, radio men, and seamen first class of petty-officer caliber, who had been with aviation units for six months or more and were capable of passing tests for a radio or aviation rating. The thousands of men in other classifications didn't have a chance.

How can you be sure of getting the kind of assignment that would make you eligible for selection? Well, you can't be sure. All men are enlisted for "general service" and do what they are told. They can ask for certain kinds of work. A very large proportion ask for assignment to aviation schools and squadrons, but only those who show the most aptitude and make the best records at the naval training stations during the first twelve weeks are assigned immediately to the kind of work they request.

If you are good enough, and if there are vacancies, you are selected for training as a machinist's mate, carpenter's mate, metalsmith, ordnance man, pho-

tographer or aerographer in the aviation branch, or to be a radio man. Those are the ratings from which prospective pilots are being chosen at present.

Obviously, this takes time. Most men who are selected for flight training have been in the navy two or more years, many of them as much as four. Of course, not all men who are otherwise qualified can pass the flight physical examination, and that gives a better chance to the ones who can.

If you are one of the successful competitors for an assignment as a student pilot you are sent to Pensacola for a one-year course. Before going you would have to bind yourself to remain in the navy for at least four years after you would be due to graduate. At Pensacola you would do substantially the same flying as student officers and cadets, but you would not take as many theoretical courses. Like all the rest you would have to be in the best half of your class in order to get through the flying course. If you succeeded you would be given your wings, and sent to piloting duty with the fleet.

While undergoing flight training you would keep the same rating you had when you entered, and upon graduation you would not be given any promotion or increase in pay on account of the rating of naval aviation pilot. But while on flight duty, both in school and afterward, you would receive "flying pay," which is your regular or "base" pay plus fifty per cent. Naturally, you would be eligible for promotion on the same basis as all enlisted men, and, due to the superior ability which got you into the school in the first place, you would probably advance faster than the average.

When you first enlisted in the navy you would get twenty-one dollars a month, uniform, food, and lodging. After the first twelve weeks you would



Part of the line-up at Parks Air College is indicative of the flying equipment available to the student. Leading air colleges maintain an assortment of planes to provide all phases of flight education.

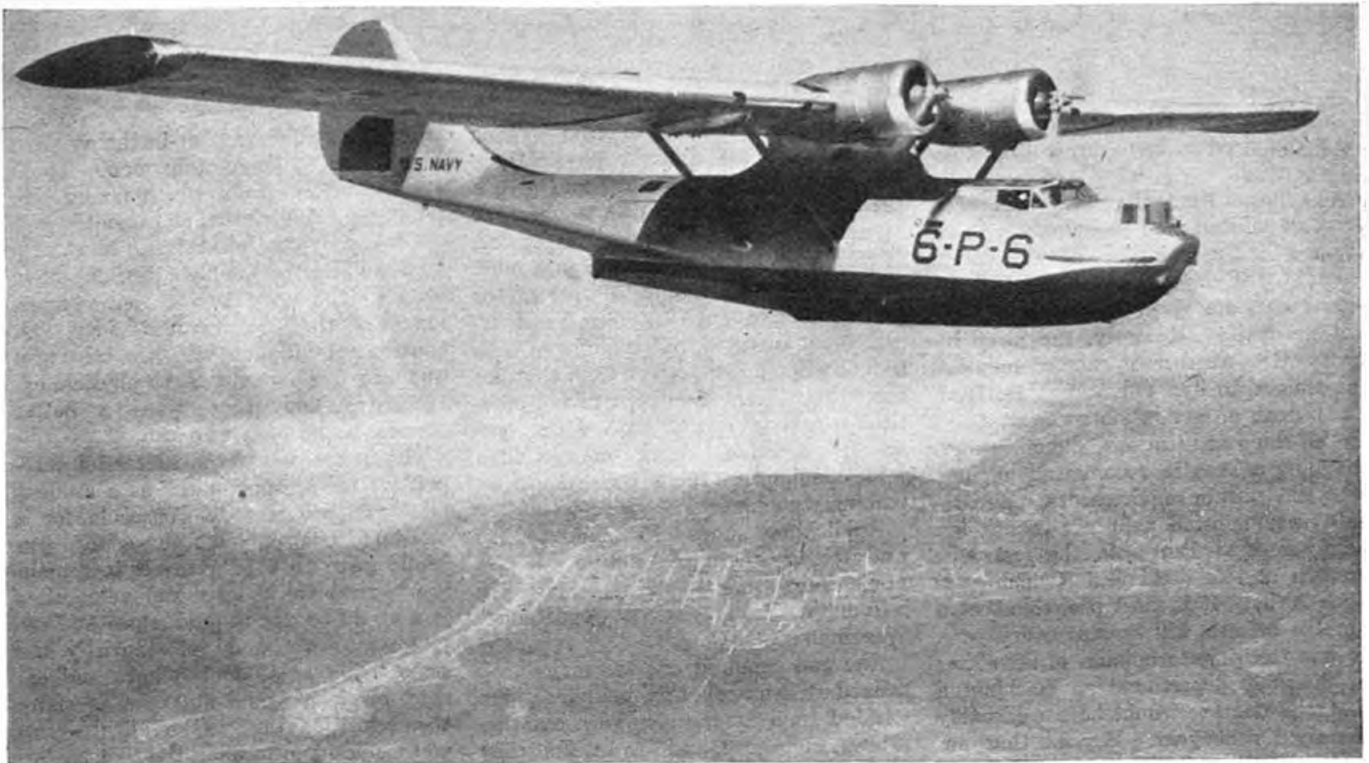

This navy Consolidated flying boat proves valuable in training for long overwater routes such as those flown by the transoceanic Clippers. Consolidated is building 176 of these patrol bombers for the navy.

get thirty-six dollars a month and then increases as you get promotions on merit. With an aviation rating on non-flying duty you would get sixty dollars a month to begin with. Promotion to higher ratings in the aviation branch would bring more pay. If you went to Pensacola within three or four years after your first enlistment you probably wouldn't have time to get beyond eighty-four dollars before being sent, though for various periods you might get fifty per cent extra for flying as a passenger.

At Pensacola you would get, roughly, from ninety dollars to one hundred and twenty-six dollars, including flying pay. Afterward, you would get increases every time you reenlisted, and those, together with promotions, could put you up to a high of about two hundred and twenty dollars a month as a flying chief petty officer by the time you had been in the navy sixteen years. You would always have food and lodging furnished or be paid from one dollar and ninety-five cents to three dollars and seventy-five cents a day extra. You would buy your own uniforms—after the first one—but would get free medical and dental attention. You might be promoted to warrant officer, in which case you would be paid from one thousand, eight hundred and thirty-six dollars up to four thousand, five hundred dollars a year, according to length of service, and with extra pay when on flying duty.

After thirty years service in the navy you could retire on a comfortable income for life. Or you might be trans-

ferred after twenty years to the naval reserve on a smaller monthly income, with the privilege of going on the regular retired list with an increase in pay in ten more years. A chief petty officer who retires after thirty years' service receives one hundred and thirty-three dollars and eighty-eight cents a month. One who quits active service after twenty years gets sixty-three dollars a month for the first ten years, and after that as long as he lives receives one hundred and ten dollars and twenty-five cents a month. A man who enlists at eighteen may thus have achieved permanent security by the time he is thirty-eight years old, and have the rest of his life to do what he pleases and make as much extra money as he can. It is rather an attractive offer to a young man who does not hope some day to be a great doctor, lawyer, editor, scientist, engineer, university president, or big business man.

But that is getting a little far ahead. Returning to the matter of getting into Pensacola, we will say little of the training offered members of the marine corps and coast guard. Not many are trained. Requirements for appointment as an aviation cadet of the marine corps reserve are about the same as for naval reserve cadets. For further information about marine corps flying write to the Major General Commandant, Headquarters Marine Corps, Washington, D. C.

Both enlisted men and officers of the coast guard are trained in small numbers at Pensacola. The Coast Guard

Academy, which accommodates about two hundred cadets in training for officers, is at New London, Conn. The school for training enlisted men for non-piloting aviation ratings is at the Coast Guard Air Station, Cape May, N. J. Further information may be secured by writing the Commandant, U. S. Coast Guard, Washington, D. C.

#### COMMERCIAL AIR-LINE TRAINING

The trim, blue-uniformed pilots, who day after day and night after night fly the great, sleek airliners of America through good weather and bad, are perhaps the best pilots in all the world. They have to be good to complete ninety-five per cent of their trips and to fly on the average about eight million miles per fatal accident. They are experts in a line of work that requires high skill, knowledge, and judgment. And they are paid accordingly. The first pilots, or captains, get close to eight dollars for every hour of actual flying and make from five hundred dollars to seven hundred dollars a month.

What we told you last month about miscellaneous commercial flying training explains how some pilots of exceptional ability got the start that enabled them eventually to land air-line flying jobs. And what we have told you about military flying training explains how a large percentage of new pilots taken on by the lines learned to fly. In our discussion of preparation for air-line flying there remains only to tell you something of the commercial flying schools of "pro-

essional" grade which specialize in training pilots for the air lines. There aren't many of them, and those offering courses which really prepare a man for an air-line career are few indeed.

The air-line pilot and operations courses of professional caliber at the best commercial schools in America are suited to the needs of certain air-line aspirants for special reasons. For instance, they are open to citizens of any country, whereas army and navy training are open only to citizens of the United States. They are open, also, to persons with no more than a high-school education, whereas the securing of military flying training by such persons, as described, above, is partially a matter of luck and generally involves around eight years of enlisted service in the navy. Also, the professional air-line courses include much study which would be of special value in air-line flying, as well as other preparation which would be of great aid in holding down a ground job in air transportation or aircraft manufacturing, in case you were unable to get a flying job or were forced to quit flying by failing the physical examination.

The best grade professional flying courses involve about two hundred and fifty hours of flying, including cross-country, night, instrument, and radio-beam flying. The training is especially adapted to meet air-line conditions, and advanced work in multiengineed craft, using all the standard air-line equipment and procedure, is included. Special emphasis is placed on instrument flying, and at least one school goes so far as to give training in blind landings by radio landing beam.

The ground-school instruction involves from two thousand five hundred to three thousand two hundred and fifty hours of classroom, shop and laboratory work, in subjects which may include theory of flight, general science, metallurgy, aircraft materials, aircraft engines, aircraft instruments, mechanics, metal and wood fabrication, airplane assembly and repair, radio code and theory, airways communication systems, aerial surveying, air law, meteorography, meteorology, aviation, air transportation, mechanical drawing,

drafting and design, salesmanship, economics and accounting, psychology, and others.

Two full years are required to complete such a course, and graduates are qualified to take the department-of-commerce tests for the transport pilot's license, the nonscheduled instrument rating, the airplane and engine mechanic's licenses, and the Federal Communications Commission test for the radio-telephone third-class license.

The total cost for the two years is from about five thousand to six thousand five hundred dollars, which includes room and board. A student is so busy that he doesn't have any time for outside work. The only chance we know about of attending one of these schools without paying the stated price for the courses taken is to be awarded one of the scholarships whereby a few men selected from among college and university students are enabled to attend the Boeing School of Aeronautics at Oakland, Calif. Information should be secured by writing the school.

It is obvious that these specialized courses are more specific preparation for air-line work than the military courses, which naturally spend more time on military subjects. On the other hand, a man with two years' military experience has had more actual flying experience, and a great many people would say more exacting flying training. The best commercial schools graduate only students of superior aptitude, but generally they are more patient with slow pupils than the army and navy. But then the army and navy admittedly wash out some potentially fine pilots.

A pilot who has had military or ordinary commercial flight training may secure special ground courses in air-line work. A two-year course such as has been described, but with the flying left off, costs about one thousand two hundred dollars, not including board, in one school. A similar course at another school, but with board and room for two years and twenty hours of flying thrown in, costs two thousand one hundred dollars. One school gives pilots with four hundred or more hours a spe-

cial air-line pilot's course in instrument, radio-beam and landing-beam flying, seventy hours in all, plus a number of air-transport ground courses. It takes six months and costs two thousand eight hundred dollars, no board included.

The best schools have been able to place a good percentage of their graduates in aviation jobs, but they do not say that all flying graduates can get air-line flying jobs. Many do, of course, and the chances for such jobs are said to be quite good, for those who have had extensive courses. However, pilots who have had as much as two years of college engineering find it helpful in competing for the new jobs as they become available.

How many new air-line jobs are going to be opening up? What are the chances for getting a job once you are prepared? And what does the future hold for young men entering air transport as pilots?

Those are questions which cannot be answered exactly and with the authority of prophecy, for true prophets are scarce these days. But there is certain information which throws considerable light on the subject. That information is more exciting just at present than ever before in the history of aviation. Next month we will tell you what we can about it. And we will also tell you something about ground jobs, of which there are in air-line operations almost ten times as many as there are flying jobs. And then, too, there are the much more numerous jobs in aircraft manufacturing, which is expanding so rapidly at present that sufficient qualified workers cannot be found.

A great many people think that aviation is on the verge of becoming a really great industry. We hope they are right—and that great things in aviation await many capable and industrious young men, rather than just a few of very superior ability as in the past. But no matter how big aviation becomes, the rewards will go to those who prepare themselves best to deliver the goods. Next month we will tell you more about how to get started.

TO BE CONTINUED.

Follow this important series of articles in next month's AIR TRAILS. Clyde Pangborn and Lieutenant Wood have made an exhaustive study of conditions.

If you read every article in the series carefully, you will know where opportunity lies in the next few years. The articles will cover every phase of aviation; ground, air, commercial, industrial, military, naval.

Don't miss the May issue of

**AIR TRAILS**

## THE FLAMING FINISH

(Continued from page 22)

Gerro shrugged. "I *have* fixed it. I know you wish to live, and I think you understand that we are not—what do you call it?—kidding you. So I know you will not win."

"The hell with it!" But even as he spoke and shoved the draft away, Johnny saw Gerro turn a quick glance toward the door. Before he could more than half rise, two men came through the door and reached his side. The silent, watchful imperturbability of their faces was sinisterly fascinating.

"Walgren," Gerro said, "these men will do exactly what I tell them. If you fly that race, you do not win it—you understand? I will accept your word."

The swift thought crossed Johnny's mind that there probably was no police assistance within half a dozen miles. He could expect no help from the waiters or the management. The place was crowded, busy, noisy, oblivious to what was happening. Gerro's thugs, at one word, as easily as not could take him for a ride.

"How do I know I'll be able to collect this?" he asked slowly, through lips that had turned stiff, and he picked up the draft again. He didn't know what he was going to do. But it was useless to resist, and he decided to accept the draft and appear to acquiesce.

"You can trust me," Gerro said. "Both for the money and to have my men on the field close to you all day to-morrow—nor very far from you at any time to-night. And if you should win the race it will be—what is the term?—too bad."

Johnny left them, crossed the floor and sat once more with Gwen. The orchestra was still playing, the trumpets *do-wahing* against the smooth-sliding harmony of the reeds. Colored floodlights sprayed shafts of brilliance on the dancers. But now Johnny Walgren scarcely saw or heard.

Gwen waited through that fox trot patiently, and then asked, "What's the matter, Johnny?"

He met her eyes, and looked quickly away. He couldn't tell her. "Nothing," he said. "Just thinking."

"Well, don't," she said. "You look exactly as you did that time a wing spar cracked and you lost an aileron. What—"

"Let's dance," said Johnny almost roughly, and got up.

Gwen gave him a straight, wondering look, and followed. The physical activity of dancing cleared his brain somewhat. But he couldn't keep his mind away from Gerro. He couldn't help visualizing what would happen if he didn't throw the race to-morrow after-

noon, and realizing in a mounting agitation what would happen if he did.

Finally Gwen said with a faint exasperation, "I don't think it's any use, Johnny. You have the grace of a two-ton truck. What on earth's come over you?"

He said, "I guess this is an off night, sugar. Let's blow."

"Blow where?" Gwen said. "We just came."

"Home," he said. "I want to see your dad."

She gave him a quick, beseeching smile. "Johnny, is it something you couldn't possibly tell me?"

He said bluntly, "It isn't anything you'd care to hear," and took her arm.



It was reassuring to know that Gwen would be waiting—when he landed.

They walked back to their table. He saw that Gerro and the other two had gone.

But even at this late hour, Dan Gibbs was not at his apartment. Johnny went to two places where Dan occasionally played poker, but Dan hadn't been there. He went home and spent a long time telephoning. At three o'clock he finally gave up and went to bed. He had to get some rest.

He lay there in bed, mind working at high speed; and he couldn't rest. The race was going to start at two o'clock this afternoon, and it would last perhaps twenty-four or twenty-five minutes. It was for a hundred miles.

Johnny flew that race a dozen times, lying there in bed, smoking one cigarette after another, getting wider awake as daylight neared. The more he flew it, the more he knew he was in a tough spot. If he won—well, he knew that Gerro meant just what he said. If he lost the race, although he made every honest attempt to win, he still would be in a spot. Sooner or later somebody would find out about that draft, even though he never cashed it.

But Dan was in a tough spot, too, and he wasn't going to let Dan down. Dan Gibbs had taught him to fly, and he'd been with the troupe ten years—since Gwen was wearing pigtails. He couldn't quite believe, remembering, that it had been so long.

Through those years they'd made a lot of money, and they'd gone from a one-ship, hand-to-mouth outfit to the biggest flying circus in the business. They had tri-motored transports and sleek, lean racers that would outrun nearly anything—a lot of modern, beautiful, expensive planes. Dan Gibbs and Bert Russell and he owned it. And, of course, Gwen—Gwen, a little eager-eyed girl visiting her father through the summer interludes from boarding school, and then, suddenly, Gwen—grown.

With a sudden resolution, Johnny sat up in bed. He had been attacking his problem from the wrong side. He knew Dan well enough to know it wasn't any use that way. Maybe Dan did not remember making the bet, but even if he did, he was too stubborn to call the wager off. So it wasn't any use to look for Dan. It was up to Johnny Walgren to win the race. He didn't know what was going to happen, if he won it, but he knew he wasn't going to throw the race away. No matter what Gerro threatened and no matter what Gerro did, Johnny knew in his heart that he couldn't throw the race. He crushed out his cigarette bitterly. This might be a tough way to go at things, but it was the only way. Somehow, he had to win—

It surprised him to discover that now it was almost dawn. Through the east window, sunrise was brushing a vivid ruddy-red into the wind-torn clouds. Coming to a decision soothed his nerves remarkably. He burrowed his head in the pillow and finally got to sleep. When he woke up it was almost ten o'clock.

Driving to the field, Johnny saw that this was going to be a tough day for the race. A puffy east wind had sprung up and was getting stronger by the hour. He'd have to watch the first pylon, where the downwind turn would be. Through his mind passed, methodically, all the things which he would have to watch.

Already, at this time of the morning, the field was overrun by the hordes of tourists and curious spectators. Cars lined the road; cars surrounded the field solidly. The blatant screeching of concessionaires was like the shrilling of sea gulls fighting over flotsam. Johnny took it all in absently, crowding through with an occasional blare of horn to draw at-

attention to the authority of his windshield sign: "Official."

In the hangar, with minutely critical patience, he went over his little maroon racing plane again. He checked every gas and oil line; he checked controls; he checked everything that could possibly be checked. It surprised him, suddenly, to discover that it was already past one o'clock. After a late breakfast, he didn't want lunch. He wished Gwen and Dan would come, so he could have a quiet moment with them before the race began. It made Johnny feel a little queer, not having Gwen send him off upon a race. It was an ill omen. He shrugged it aside. Superstition never bothered him. But he felt it, just the same.

At one thirty he helped roll the little crock outside the hangar. He started the engine and warmed it carefully. Then he taxied slowly to the starting line and took position between the little white monoplane of Dennison Carter and the black one of Duke Harde. The engine whispered to a stop when he eased the altitude control full on.

Johnny sat there, checking his gas valves and engine instruments, reviewing once again the campaign he had laid out for flying this hard-contested race. All along the line, in the nine planes, other pilots were adjusting themselves and getting ready for the starter's flag. As usual, this was going to be a race-horse start, and the advantage gained at the first pylon might decide the struggle.

Duke Harde, twenty yards away, looked across, grinned and flaunted fingers at his nose. Johnny waved his hand. It was surprising how his rigid, fatalistic disregard for what might happen had taken on almost a narcotic quality. He wasn't at all nervous. But just the same, he wished Gwen had come; he wondered what had happened to her.

Down the line, an engine barked out, and the prop flashed silver. One by one, the motors took life noisily. Johnny pressed his starter button and listened critically to the hearty eagerness of his rumbling exhaust.

The green flag of the starter poised there. Even above the mutter of the engines, the roaring of the crowd came dimly in an undulating wave of sound. Johnny started to pull his goggles down upon his eyes.

Just then, from the spill of his vision, he caught sight of a figure hurrying along behind the planes, and saw that it was Gwen. She was alone. She was running, high-heeled slippers wrenching her ankles cruelly. She reached the cockpit. Her face was pale and the prop blast took her breath.

"Johnny!" she gasped. "I just found out—Cuban revolutionists are trying to get the circus. They tried to buy—"

Through her words Johnny heard the smashing thunder of the other engines as they responded to the starter's dipping flag.

"Get back!" he yelled to her.

Dust and the reek of engine fumes were in her nostrils. Already the other planes were under way. But he couldn't gun his engine until Gwen got clear of the tail.

"Get back!" he shouted, and saw her lips move and saw her stagger out of danger as he slammed his throttle wide.

In the blinding wake of the other planes, he took off without seeing anything but sand and dust. The field was rough and his wheels bounced in and out of sink holes. He almost crashed before he ever got into the air. He hit a ridge and the plane leaped high.

In a breathless stall, while the turbulence of other prop blasts tossed him like a leaf, he didn't know for a moment whether the plane was going to fly or spin. If the motor had as much as sputtered once, he would have crashed in on a wing. But the motor didn't sputter, and he slowly eased the nose down and fought frantically for speed.

It was incredible how much the others had already gained in the dozen seconds of delay. Duke Harde was already well ahead, and Johnny knew that this was a handicap which only skill and desperate piloting would ever overcome.

Two miles separated him from the rearmost of the other planes. Johnny could see the thin spans of wings attached to fuselages. He saw them grow into a clot and bunch dangerously and turn together at the hunting tower, sweeping back upon the straightaway.

He fixed his eyes upon the pylon; he was trembling with a harsh excitement

now. Bumps chopped at him. The engine revved snarling to two thousand and then still upward, laboring into a deep-toned reverberating howl. The air speed quivered at two twenty and then two thirty and then two forty, where it hung.

The pylon leaped back from the horizon. Johnny judged his speed and distance tautly. He took in a deep breath and held it tight against his belt. He banked up swiftly vertical around the tower.

Blood sang and pounded in his ears, draining his eyes of sight. He had no consciousness of fear. His brain was tightly concentrated on the grim necessity for holding on and never varying the turn. He couldn't see at all, now. If he varied, if he let the nose get down, the hurtling little craft would crash and strew him and its wreckage in the palmettos. He held on and then, in relief, eased the turn off. His vision cleared. Ahead, there, were the thin spans of those other wings again, and he could not see that he had gained on them at all.

They were stringing out, now. Duke Harde's little black crate was streaking past the grand stand on the beginning of the second lap, far in the lead. Johnny hit the second turn with smooth precision and came thundering down upon the grand stand at a hundred feet. Going into the turn, he got a quick glimpse of a sea of upturned faces, and something of the frenzy of the crowd was transferred to him as he realized he was slowly, surely, gaining on Duke Harde.

But he *should* be gaining—he was staking his life on every turn, taking it closer, lower, faster than the last. Knowing that if the race lasted long

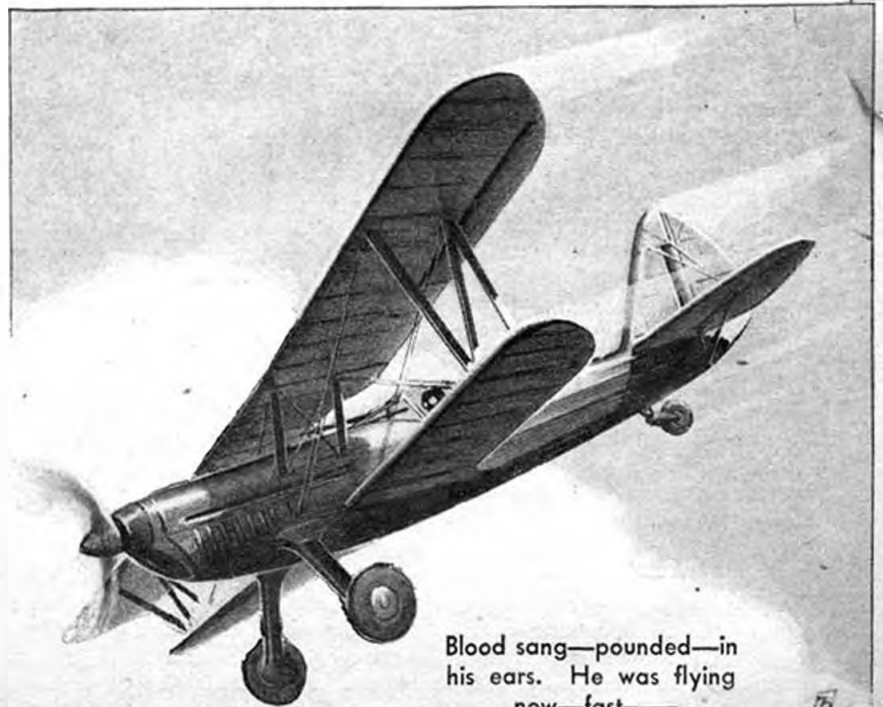

Blood sang—pounded—in his ears. He was flying now—fast—

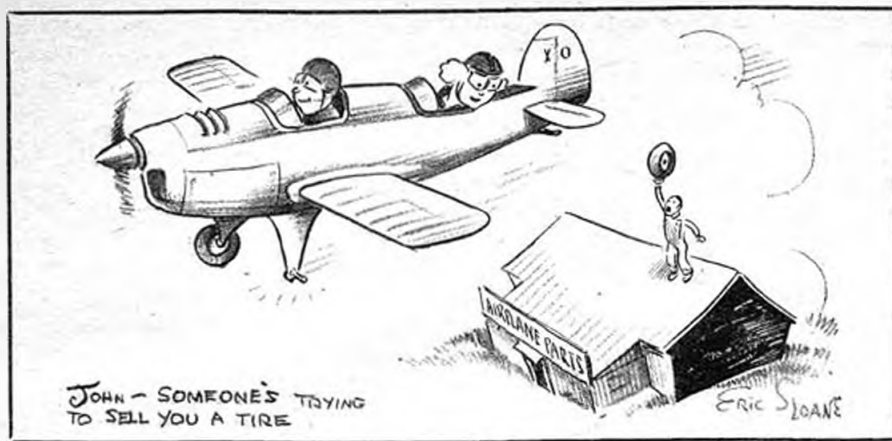

enough he would have a chance to nose Duke out, he settled to the grim routine of holding on.

Thinking of Gwen, he recalled what she had said. What was it—that Cuban revolutionists were trying to get Dan's planes? He didn't doubt that. The angle on the Englishman who had made the bet with Dan was mystifying, but it was obvious that Gerro was a Cuban. Cuba was overrun by rebel bands, and a rebel leader could not strike effectively without an air force—nor could he purchase modern military aircraft equipment openly. In the whole United States there was no group of private planes so adaptable to military use as those which Dan Gibbs owned. If Gerro could obtain them, arm them and fly them to some obscure Cuban field, the next revolution might be a really potent thing.

His mind came sharply back to racing, as he whipped out of the second lap into the third. He had gained almost a mile, but he was not gaining nearly rapidly enough. There were seven laps in all, and two of them were finished; he still had more than a mile to gain on Duke—before the hair-raising task of passing Duke was reached. You never passed Duke without a battle, because Duke never failed to call a bluff. But there are breaks in racing, and Johnny fought his way past plane after plane, gaining steadily, and prayed and waited for a break.

Always, now, he shaved the pylons closer, swinging past them in shortening, breath-taking arcs, his lower wing almost clipping grass. Speed—speed—speed! It sang in his blood. It drugged his brain, a powerful stimulant. Bluffing the pilot of a little blue crate on a turn, he moved up into fourth position, finally, with less than twenty-five miles to go. He moved grimly into third position, taking his life in his hands.

And then he almost lost it in one propeller beat.

Monahan's golden twin-row Comet job was just ahead. Johnny was moving up, streaking up, doing two fifty and holding his breath and timing the

beginning of the turn before the stands. He took his eye from Monahan, watching the pylon. When he looked again at the golden plane, he saw that it was belching a long spume of heavy smoke.

His concentration on that pylon almost killed him. He didn't see, until a split second before the two planes were going to come together, that the Comet was slowing fast and he was overrunning it. He couldn't turn; he couldn't dive, because both planes had less than a hundred feet already. Monahan's big engine had gone dead, and Monahan, intent only on getting clear of that thundering herd behind him, suddenly pulled up.

And Johnny, doing the only thing he could do, pulled up, too!

He snatched the throttle shut. It seemed to him that there was nothing in the world as big as that gilt-colored plane before his eyes. He felt his own prop knife shuddering into Monahan's rudder. It made him cringe to think that Monahan would be left in the air without control, too low to jump. And then, in a fraction of a second, the golden plane had dropped below and out of sight and Johnny Walgren could hear nothing but the pounding of his heart. A moment later, as he swung trembling around the turn, he saw Monahan glide safely to earth in an adjoining field.

He realized numbly that the race was lost, although by that time his throttle was wide open and he was once more in desperate pursuit. Instead of helping him, the break that he had waited for had ruined everything: a carburetor float had stuck, maybe, on the Comet job.

Suddenly, thinking of that carburetor, Johnny leaned down and moved his altitude control ahead, watching the tachometer. Of course, he'd known all the time that air-cooled racing engines were set at extremely rich mixtures, because at wide-open throttle the surplus gasoline acted as a cooling agent. And he'd known that even at sea level, opening the altitude control would lean the mixture and would give more engine revvs. You never leaned the mixture,

in a race, for doing so would burn your engine up. But if he could get five minutes at a higher speed, before the engine went—

And as he watched, he saw the tachometer needle waver upward—forty, fifty, sixty—almost a hundred revvs! The air speed climbed. The little plane gained ten miles an hour before it reached the next pylon.

Johnny could almost see the distance between the two planes narrow, now. They took the east pylon a half mile apart. His cylinder-head temperatures were climbing, and he prayed the pistons wouldn't melt. The plane was screaming at the wind, the engine moaning in its labor. The bumps were live things, incredibly vicious. All the heart that was in man and plane was straining to the utmost.

They were close, as they slashed around the final pylon. Eight miles of straightaway lay ahead—and then the finish line. Johnny was above Duke Harde, and two hundred yards behind. Brown earth smeared past below at reckless speed. The gap between the two ships closed. They were flying wing-to-wing. In the stands a hundred thousand people were going mad with frenzy. Johnny moved up. If that engine stood up, nothing could stop him. Duke Harde looked across that space; his face was tense and worried.

And then Johnny Walgren got a whiff of something in the cockpit. His scalp went stiff with fright. He scarcely noticed when he passed Duke, for he was sniffing at that smell. Paint and oil. But there was something else—somewhere there was flame. Goose flesh broke out along his neck.

He could see the smoke, now. It came back into the cockpit through the floor, spewing up and whipping back across his shoulders. It was in his face, and it stirred subconscious fears which he didn't know he had and which he couldn't overcome. He sucked in a lungful of that hot, stinking air, and it stirred his nerves almost to panic. With the greatest difficulty he fought to hold his lead on Duke, and tried to disregard what he knew was happening up there.

Then he couldn't disregard it any longer. A violent knocking started in the engine. There was a sharp, metallic, clanking sound, and then a sudden, shivering explosion. And with the explosion, the engine quit, and open flame burst back along the fuselage.

Johnny acted with a mechanical response, now that he knew there wasn't any doubt about the fire. He never changed his course. He reached down and pulled the engine fire extinguisher, knowing that it could only delay the flames and couldn't put them out. He turned off the gas, to keep the fire from the tanks. Over his shoulder, in a frightened glance, he saw that Duke was

crowding close behind him; Duke was going to pass him in a moment now.

Then, in a vast gratitude, he saw the grand stand flash underneath his wing, and knew that he had won the race.

But he had no time to think of that. Flame was eating back along the fuselage, and it was getting hot inside the cockpit. Johnny zoomed breathlessly, without power, riding out his speed. There was no lift left in the shattered engine. To get away from the snarling planes behind him, he turned toward the west. It was downwind, and swamp land lay in that direction; but he couldn't turn east because the airport was crowded with pedestrians.

To get out of this alive he had to zoom high enough, on speed alone, without power, to be able to use his parachute. He wasn't sure he could. He wasn't even sure he would be able to get out.

Smoke was choking him now. Flame scorched his face and hands, until he couldn't stand it. Even if he died, he had to get out. He clawed his way over the cockpit rim, blinded by smoke, and kicked away. The plane was gone instantly. He pulled his rip cord and the parachute boomed open dully. The sweet air was caressing to his lungs, and he didn't notice until he was almost to the ground that he was going to land in the exact center of a tremendous

bog, at least three miles from any road or highway.

Five hours later, under the brilliant stars, he met the searching party, coming after him. For a moment of alarm, he thought it was Gerro, and he shrank back into the darkness and swamp grass. Then he recognized Dan Gibbs' booming voice, and reemerging, showed himself. Dan, it developed, had brought two policemen with him.

"You hiding from that Cuban?" Dan asked.

"That was the general intention," Johnny said, relieved.

"Forget him," Dan said, puffing from exertion. "He made the mistake of telling an Englishman that he was going to bump you off to make sure of that crazy bet of mine. Courtney was a white man, and that was just too much for him. He was Gerro's front, trying to buy the circus. I don't remember the details, but they say I wouldn't sell the circus but I bet on your taking the Benson Trophy go. Why didn't you tell me about this Gerro's threat, kid?"

"I tried to tell you," Johnny said, "but I couldn't find you." Relieved of fear and worry, Johnny was suddenly unendurably exhausted.

"I spent the night with Courtney looking for Gerro—and all the next morning," Dan said. "We found him

and slapped him in the jug. When they get around to it, they'll deport him. Kid, you should have told Gwen, so we could have started to help you sooner. One thing you want to learn is that a woman's going to find out everything about you, anyhow, so you'll save a lot of trouble if you just tell her everything in the beginning."

In the starlight ahead Johnny could see the vague outlines of automobiles against the sky. It was reassuring to know that Gwen was waiting for him there.

"I guess maybe you're right," he said to Dan.

"Sure, I'm right," Dan said. "Well, kid, I got sucked in for rebel bait because I got down off the wagon, so I guess I'll get back on again. This time I really mean it!"

Johnny grinned. He had known Dan Gibbs for ten years. "Sure," he said. This burst of temperance might last a month, six months or even a year. But sooner or later Dan would climb down again, "to try his legs."

When that happened, he might try to buy the White House, or decide he was a Cuban general himself. But it was all right—doing it, he would provide excitement. Dan never did the same thing twice, at any rate. Around Dan, you needn't ever worry about monotony, or about being bored!

## THE FOKKER G-1

(Continued from page 48)

Cover the bifuselages first. One, as example: cover top, then bottom between B1 and B3; top, then bottom between B3 and B4, and all around between B4 and B5. Make paper patterns of each section before cutting  $1/64$ " sheet. The patterns can then be used on the other frame.

The cabin is simple to cover to the bottom of the wing, but make paper (full length) patterns first. The bottom should be covered with full-length "barrel stave" shaped strips of  $1/32$ " sheet, about  $3/8$ " wide, starting at the center of the bottom.

Cement the landing gear in place. Cement the cowls and forms to the bifuselage and the nosing to the cabin.

### COLORING AND DETAIL

Spray the whole model with clear lacquer thinned to  $1/2$  and  $1/2$ . Let it dry and then sand all over with fine paper. Mark the spaces for the insignia colors and mask over them with masking tape or in a similar manner. Cement on all detail except cannons and celluloid parts. If cut-out observer's windows are preferred, cut them now.

The whole model is now sprayed with a hand spray (or professional gun, if available). The color is "U. S. blue,"

thinned half the original consistency, and must be lacquer, instead of dope. Dopes will ruin the sheet covering. One light coat sprayed on should suffice, whereas, by brushing, two heavy coats might show streaks.

Remove the masking and brush on the "imaginary insignia" of red and white bands, where indicated. Now cement the celluloid parts on, the tail wheel, aluminium tube guns. Paint tires and motor fronts black.

### PROPELLERS

Note on Drawing 1 the provision made to increase the endurance of the flying model, by adding special nosings to the motor fronts, so  $5/8$ " longer props can be used.

Make 6 propeller blanks; cement 3 together to make the two three-blade blanks. Carve one left-handed propeller and one right. When cementing the propeller shafts on, bend winding loops on the front.

### FLYING THE MODEL

The original model weighs 2 oz., ready to fly, with each propeller powered by 6 strands of  $3/8$ " flat lubricated rubber. After installing the rubber, lightly cement the tail assembly to the bifuselage

ends. The model must balance along the main spar.

Make the first glide and power tests in a field of tall grass. If tall grass is not available, make the tests r.o.g., gradually increasing the number of motor turns until perfect adjustments have been made.

### MATERIAL LIST

- 1 cabin nose block  $1\frac{3}{4} \times 1\frac{7}{8} \times 2$ "
- 2 fuselage form blocks  $\frac{3}{4} \times 1\frac{7}{8} \times 1\frac{7}{8}$ "
- 6 propeller blocks  $\frac{3}{4} \times 1 \times 2\frac{3}{8}$
- 8  $1\frac{1}{16} \times 1\frac{1}{8} \times 18$ " strips
- 18  $1\frac{1}{16}$ " sq. x 18" strips
- 20  $1\frac{1}{64} \times 2 \times 18$ " sheets
- 2  $1\frac{1}{32} \times 2 \times 18$ " sheets
- 2  $1\frac{1}{16} \times 2 \times 18$ " sheets
- 1  $1\frac{1}{8} \times 2 \times 5$ " sheet
- 1 oz. tube model cement
- 12 ft.  $1/8$ " flat rubber
- 18" #14 music wire
- 6" #12 music wire
- 4" #8 music wire
- 2 3x6" celluloid sheets
- 2 oz. blue lacquer
- 1 oz. clear lacquer
- 3 oz. thinner
- 2 dram each red, white, black lacquer
- 6"  $1/16$ " alum tube
- 2"  $3/32$ " alum tube
- 6  $1/8$ " friction washers



# "DEAR HARRY—"

(Continued from page 28)

And allow me to say that I am going to win that race."

With which words I stroll away, followed for some distance by Bronx cheers.

Crosby and Crosby's gang are not through yet. Next day they seek conversation with me again.

"Sterling," Crosby says with a smirk, "we've been thinking things over and have come to the conclusion that there ought to be a prize for the winner of the air race. Seeing as you'll be flying the fastest ship"—chuckles break out at this point—"and will have the best chance of winning, why don't you put up a prize?"

General haw-haws fill the air.

I wait till some measure of silence has fallen and deliver myself of speech.

"The idea is entirely agreeable to me. I'll see Norwood and give him \$10, which he can hand to the winner of the race."

That sobers the Crosbyites. They stare in a very surprised fashion and can think of nothing to say. I depart for Norwood's office and put up the \$10—every last cent I have in the world, by the way.

Some time later I am walking by a hangar when I hear voices inside. It is Crosby and his henchmen, arguing heatedly.

"Sterling must have something up his sleeve," one of them is saying. "He

wouldn't donate a \$10 prize for nothing."

"He can't have," Crosby, himself, asserts. "You know as well as I do that No. 7 couldn't win a race with a turtle. And according to the rules he's got to fly No. 7 and no other ship."

Just then somebody rushes into the hangar.

"Hey, I've got some dope on Sterling!" he yells.

All attention is turned to the newcomer.

"What is it? What've you found out?" Crosby snaps.

"I've found out," comes the answer, "that the mechanics are working on No. 7. They've got the crate in an empty hangar and are keeping the doors locked."

Silence reigns for a second.

"So," Crosby sneers. "Well, that'll do Sterling a fat lot of good. The mechanics can work on that ship till it falls apart, but it'll never be any better than it is now."

The meeting breaks up.

Time speeds by. The mechs continue working on No. 7 behind bolted doors. Every so often I inspect the crate to see what progress is being made.

Comes—the day of the race!

There are to be 7 planes in the contest. As the hour of the take-off approaches, 6 are rolled to the line and

warmed up. No. 7 is the only one left to make its appearance.

"Where's your ship?" Crosby demands.

"It's not quite ready," I answer. "But I'll get away on the scheduled time, or close to it."

According to the rules, the planes are to hop off at intervals. The winner will be the pilot who makes the best time over the course. Crosby is to take off first. I am to take off last.

Crosby gets away. Down the field he goes and lifts his ship into the air. Shortly after the second plane leaves the earth, then the third, fourth, fifth—and sixth. But the sixth does not get far. Too eager to get going, Crosbyite Benton takes off with a very short run. The ship sinks and Benton tries to remedy his error with a good bounce off the ground. The plane bounces all right, but also blows a tire, ground loops and bends a wheel.

Benton, plenty peeved at being out of the race, stalks up to me.

"Well, anyway, I *might* have won the race," he growls. "You can't possibly win. Where's your plane?"

At that moment old No. 7 is pushed out of the hangar and trundled up to the line. The motor bursts into a healthy roar. At the sound, Benton stares hard.

"Hey—what—is that a new motor?" he blurts.

"It is," I yell over my shoulder as I sprint for the ship. And so the secret comes out. Not only has a new motor been installed in No. 7, but the new motor is *more* powerful than the old. You see Norwood had obtained a new and heavier motor for No. 7 some time before. Hearing of it I had persuaded my friends, the mechanics, with Norwood's permission, to install the kicker at once and secretly.

"Hey, this isn't fair," Benton hollers at the side of the cockpit.

"Nothing in the rules that says it isn't," I holler back, and open the throttle.

The motor talks out loud and the backwash blows Benton away. Down the field I tear, and into the sky I climb. Boy! What power there is in old No. 7 now! I level off and let 'er go. The needle of the air-speed meter walks across the dial to an all-time high.

It isn't long before the first plane comes in sight. Apparently the pilot is having trouble, for he is making a low number of m.p.h.'s. He looks up sourly as I breeze by, evidently not noticing the item of my brand-new motor.

The second ship heaves in view. I bear down on it and fly wing to wing for a few seconds. This pilot looks at me in astonishment, and instantly ob-

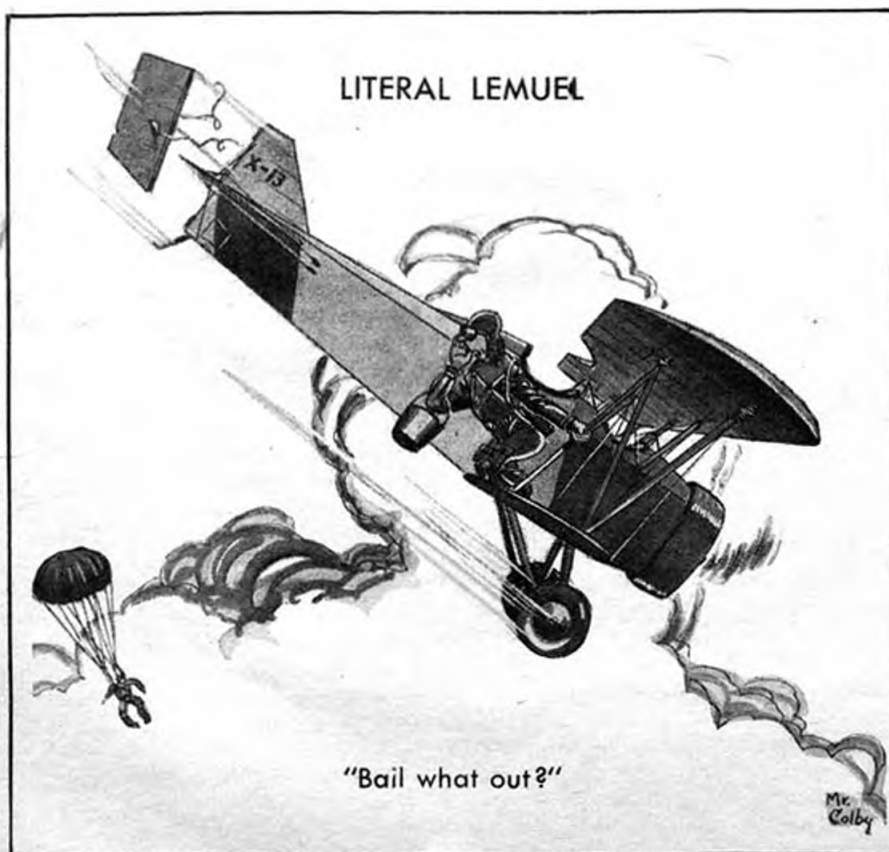

serves the strange power plant in No. 7's nose. He gasped, and that is all I can record of his actions, as just then I crack on the gun and leave him in the distance.

After this victory I retard the throttle and look at my watch. There is to be a grand finale to this race and it must be timed right.

After a while I open up again and hit top speed. Three planes remain ahead. I spot one, pass it nonchalantly, spot a second and pass it with a wave. Now only Crosby is left to be vanquished. I lean forward in the cockpit as I search for his ship.

There it is!

Yes, there it is, but my timing is faulty. The Hartland Airport is in sight and Crosby is gliding down for a landing. He must not get there first!

I am up fairly high. Forward with the stick and into a steep dive with the motor thundering full out. The whistle of the wires rises sharply.

Crosby is 1,000 feet ahead—500—100. I sweep past him with a roar and go down to a landing. All I can see in the instant of passing is Crosby's upflung head and amazed face.

That night all the students gather to see the awarding of the prize. Crosby and his henchmen talk themselves into exhaustion trying to convince Norwood that the race was not fair because of No. 7's more powerful motor. Norwood listens attentively and then speaks.

"It is my judgment," he says, trying hard not to smile, "that no rule of the race was broken by Sterling. Therefore, I present the prize money to him."

And that is that. But, oh my!—the grating of teeth from the Crosbyites can be heard all over the room. I make a mental note to be on the alert after this, for I feel that there will

surely be a revenge attempt directed at my head.

My hunch is correct, but, even so, I am caught off guard.

To go back a bit, one day upon landing in a near-by town I made the acquaintance of the members of an aviation club. The members of this club range in age from 14 to 44, but they are all flying fans and listen with great interest to my stories of air-school experiences when I address them at their meetings (didn't know I was a lecturer, did you?).

When an 800-horse-power superspeed transport plane comes into the Skyways field I immediately think of the aviation club. Would they like to see this transport! Right away I contact Norwood to see if I can borrow the plane. Norwood's verdict is O. K. and he delegates Kinley to fly it for me. I have not as yet reached the point where I can fly transports. Over we go, after I have telephoned and found that the club is in session.

Arrived at the field, Kinley departs for the hangars and I depart for the clubhouse. There I give the assembled members a description of the high-powered ship, tell of its tremendous speed, huge motor and large cabin; generally whet their appetites for an inspection of the plane. Then I lead the whole bunch back to the field.

As we are about to round the corner of the hangar and bring the transport into view, I am talking thus: "This ship is outstanding among the commercial aircraft of the world. With its superpowerful motor, exceptional passenger-carrying capacity and high speed it is unequalled—"

We round the corner.

I throw out my hand to point to the

big plane, but my hand falls, while my mouth drops open at the same time.

The transport is gone! In its place is a light plane, a ship with a motor-cycle engine, passenger-carrying capacity of one, and speed of maybe 60 miles an hour. Am I embarrassed!

I become aware that some one is speaking to me. It is the president of the club.

"Mr. Sterling," he says in a north-pole voice fairly dripping icicles, "it seems that you have brought us here simply for the purpose of playing a joke, and a childish joke, I might add. On the part of the members and myself I wish to say that we will dispense hereafter with your visits to our clubhouse."

And despite my attempted explanations they all leave the field.

I stand there a moment after their departure and suddenly hear gleeful laughter.

It is Crosby and his followers!

In a flash I see it all. Getting wind of my trip and its purpose, they followed and attended to the replacing of the transport with the light plane. Sweet revenge for my winning of the air race.

With the sound of their cackles in my ears, I go hastily away from there.

Well, eventually I make up with the aviation club. Kinley vouches for my good intentions and we bring the transport over again for their inspection. But my ears still burn when I think of the trick Crosby and his henchmen played on me.

Oh, well—maybe—just maybe—I will in the future find a chance to pull something on the Crosbyites which will make their ears burn. And so—till my next letter,  
Yours, STEVE.

## TAKE IT AROUND

(Continued from page 26)

ability on my "three-flag" record run from Canada to Mexico in eleven hours, one minute. She had been groomed for a tough grind.

Other equipment besides the ordinary engine instruments, magnetic compass, altimeter and air-speed indicator was a parachute, pistol flares for night flying, navigation accessories, some seventy-odd maps, and a Jones Brothers' avigator, probably the most important aid to navigation (excluding maps) I had, for I carried no radio.

I had spent many nights checking and rechecking maps of the route. With hardly any auxiliary fields and plenty of "graveyard" country, I felt that this particular phase of the preparations could stand plenty of overtime thought.

The Los Angeles Junior Chamber of Commerce sponsored my flight and arranged for me to clear customs and immigrations at Mexico City, instead of

having to land at Mexicali. To make Mexico City before dark, I would have to take off for Hermosillo at midnight and fly all night without beacons or check points. There is no night flying at present in Mexico, even by the transport companies, because there are no facilities.

At eleven the weather started to close in. I was more than anxious to leave because the take-off had already been delayed almost two weeks. The commanding officer cleared me (an army regulation where civilian aircraft is concerned) and gave me a final weather report.

The blocks were pulled and I pushed the throttle forward at exactly eleven thirty-four. The Menasco growled into the night air as the ship began to roll along, gathering speed gradually.

In just ten minutes fog closed the field in tight, while I was slowly gain-

ing altitude. At seven thousand feet I leveled off, swung to a southerly course and settled down for the night. The moon seemed my only friend, for as the minutes passed so did California and our last check mark—the beacon on the Pan American field at Mexicali.

The long night lay ahead. Nothing but the moon and instruments showed, and even the moon scheduled to set in another hour. All I could do was sit and hope. Everything depended so much on this first leg—whether or not I could hit that little town of Hermosillo just a few minutes after dawn.

At regular intervals I'd check the fuel gauges with my flashlights and wobble gas from the reserve tank in the fuselage up to the main tanks in the wings.

I made another course change, this time eleven degrees, to allow for the twenty-two-mile-an-hour westerly out of Guaymas. Slowly the eastern sky

grayed. Dawn at last! I craned for a possible glimpse of the railroad which runs into the little town at a thirty-degree angle. Smoke appeared off in the distance. I felt thrilled, for it must be a train. As the smoke came closer a village appeared like a mirage and Hermosillo rolled directly under the nose. I couldn't make myself believe it until I sighted Pan American's field and saw the attendants run out to refuel us. With this first hazardous leg over I felt certain of making Mexico City.

After a fast refueling I was in the air again and headed for Mazatlán. Everything was as smooth as glass as I skimmed over the mountain passes, and I soon became drowsy. Before I knew it I had fallen asleep and awakened in time to catch the ship in a slow right spiral, headed for a mountain peak. I rolled the stabilizer back so that if I went to sleep again the ship would automatically assume a climbing angle.

About five hours had passed when I sighted the sub-tropical city of Mazatlán. A quick army one-hundred-and-eighty-degree and we were on the field. I lost valuable time refueling, because their hose wouldn't fit the tanks and drums had to be rolled from the stock room. When we took off, the hour's safety factor I had allowed myself to get into Mexico City before dark was now gone.

I chose a direct course between Mazatlán and Mexico City with Guadalajara the first check mark, three hours away. It was as bad a country as any one could choose to fly over and was without check marks or emergency fields. Soon I was over the famous *barrancos*, mountain cuts. It was graveyard country and in case of motor failure one would have to trust to his parachute.

Guadalajara was logged as we passed and to the north. The last leg was a hop over. The sun was dropping and it was just about dark when we passed over a small cornfield an hour later. The Mexico City beacon had been turned on for us. It was located about fifteen miles west of the city, and in good weather it might possibly be sighted as far as seventy miles out. I continued in the hope of catching a glimpse of it. Ten minutes farther and still no beacon, so I turned around and headed for the cornfield while I could yet see.

It was well-plowed and filled with burros. A bit of "cowboy flying" fixed the burro part of it and I was ready to try the landing, figuring for nothing less than a nose-up if I were lucky. *Yankee Boy*, with a decidedly indifferent attitude toward it all, stuck his nose in the air and sat down without even wrinkling his pants.

A few minutes after landing, the ship was surrounded by Indian peons, who had come out of the hills from every

direction. In Africa it's bright beads that attract the native eye, while in Mexico it's flashlights. I found them to be a source of wonderment to these almost wild Indians, when I took the flashlights out to look over the ship for possible damage. By morning the lights had all been given away, along with many other articles, as the price of getting a runway built.

It would be a dangerous take-off; there was no escaping that! The improvised runway was too short and it would be necessary to strip the plane of every extra ounce of weight. More than two hundred pounds of gasoline was drained, baggage and extra oil unloaded and many parts dismantled and taken off the ship, including the pants. Everything was placed on burros then, and started over a rough trail for Maravatio, a village on the Sud Pacific Railroad, where I shipped the things to Mexico City and sent word there that I was O. K. and would soon proceed to the capital.

I landed at Valbuena Field in Mexico City just sixteen hours, eleven minutes flying time out of Los Angeles.

Here I was received by the President of Mexico at the national palace. Commander Fierro and the officers of the Mexican air corps gave me a luncheon at Chapultepec and made my stay a very enjoyable one.

Between weather which prevented flying, and hospitality which prevented leaving, I stayed two weeks instead of the two days I had originally planned. But on a Sunday night a promising weather report was radioed through from Brownsville, allowing me strong tail winds all the way to New York.

Early morning had been chosen for the take-off, for at this time the air is cooler and heavier. It is a difficult task to take a plane, heavily loaded, off the ground at sea level, but at this altitude it requires extreme caution and careful judgment. Another final check of controls, instruments, motor and magnetos, and when the engine reached its maximum r.p.m., I released the brakes and we started to roll.

It was afternoon when we left Corpus Christi and started out over the

Gulf for New Orleans, with nothing but water and a long afternoon to anticipate. The light-green water along the coast changed to a deep blue, and now we were well on our way over the "drink."

During the afternoon I pulled up as high as ten thousand feet and back down again to within a few feet of the water.

At times I had a more secure feeling when we were flying high above the clouds and the water was not visible below. Everything was going smoothly. I was afraid to speak now for fear of breaking the charm that had kept the motor running so smoothly.

Suddenly I glanced up to discover my compass had taken time out, and over the Gulf of all places! Another hour passed—now we were almost five hours out.

Point Tigre was to have been the first land fall at four and a half hours. It was almost dark as I began changing to a northerly course by fifteen-degree intervals.

Although I felt certain of my position, I wanted to sight land before dark. The situation was becoming tense. I picked up the lights of a ship, the only one sighted during the crossing, and took a bearing from its wake, setting a new course for New Orleans.

With the gasoline supply fading rapidly, we reached the coast line and headed in over the alligator-infested swamps. It was a good hour's flight to New Orleans if I were steering the right course, and I only had an hour's supply of gas left. I hated the thought of leaving *Yankee Boy*, but there seemed no other way.

A forced landing in these swamps in the day time would be hazardous at best, but at night it would be practically an impossibility, even with the aid of flares. Still no sight of New Orleans!

I was waiting for the gas to run out and was going to trust to my parachute. It would be a sad finish after we had come so far together. If I could only pick up some lights in any direction, I would still have a chance to get *Yankee Boy* down.

#### Lights!

There was no mistaking them—just ten degrees starboard and lots of them. They just had to be those of New Orleans. With the motor throttled back, my plane slid in over the queen city of the Southland. Never did anything look so good as the green-and-red lights of Shushan Airport that night.

At the airport I was informed by the mechanics that I had just three gallons of fuel left in the tanks, a bare few minutes in the air. As I checked over the ship, prior to taking off, I found the patched inner tube I had carried as a life preserver lying flat behind the tanks.

My next stop, Atlanta, furnished a



surprise, also. When the flood lights were turned on as I circled the field, I noticed a large crowd of people gathered at the administration building. Upon landing, the crowd surrounded the ship and three men introduced themselves as customs officials and informed me I had entered the country illegally.

I was certain everything had been taken care of by the Camara de Comercio in Mexico City. They were determined to end my flight for the night when some one in the crowd asked if I didn't know any one in Atlanta. Yes, of course, I knew Louisa Roberts, daughter of Laurence L. Roberts, assistant secretary of the treasury, and in just a few minutes they had called her to the phone. Ten minutes after she had talked with the officials, I was again riding the beacons.

After hours of rain, which sometimes almost forced me to the ground, I sighted the lower bay and Manhattan out of the dense haze. Before me lay big and beautiful Floyd Bennett Field and, with a quick circle and a slip, I landed, twenty-two hours, four minutes flying time from Mexico City.

I was the guest of the city of Newark during my stay and was received by Mayor Ellenstein at the Newark City Hall. I was given a medal by the mayor and a cup by the Junior Chamber of Commerce. From there I went to the New York City Hall and met Mayor LaGuardia, himself a former flier.

By this time *Yankee Boy's* motor had been thoroughly gone over and I took off for Washington and the White House, where I delivered the letter of good will from President Cardenas.

Then I stuck the nose out over the Alleghenies and headed west, choosing the northern route to the coast by way of Cleveland, Chanute Field, Rantoul, Omaha and Cheyenne.

Thirty miles out of Cheyenne, what had been a normal head wind turned suddenly into a strong down draft whipped by a seventy-five-mile-an-hour wind. This section of the Rockies is famous for its down drafts, caused by winds blowing over the "hogbacks." The heavy load and the high altitude made it impossible to get more than two hundred feet of altitude at any time. Time and again the ship "dropped out" and only the "ground cushion" averted a crack-up.

At times I was turning down ravines to keep from hitting the ground. To turn back with this strong wind and heavy load would be hazardous, and to continue was impossible. So, there was but one solution—to land.

My field proved to be the side of a mountain, and as soon as I cut the throttle the ship would start to roll back. I stopped the engine and jumped out to hold on to a wing in the hope that the ship wouldn't blow away. By jockeying the wing into the wind, I was able to get the plane down the hill to

a low spot where, with the tail into the wind, I anchored it by lashing the parachute under the tail wheel.

I remained with the ship all night, in the cold weather. In the morning I wandered off toward the east and picked a stream which I followed down to a ranch house. Lack of facilities there prevented my communication with any one, so, with two ranchers, I returned and got the motor started.

To get off, it was necessary to strip the ship of flares, baggage, oil, a few parts and instruments. Besides all that, more than four hundred and fifty pounds of gasoline had to be dumped before I tried to get in the air.

My first attempt resulted in being forced back down by the same down drafts, and one of the ranchers remarked, "You sure looked like you had your feathers plucked that time, son."

The second attempt proved more successful, for I was able to get enough altitude to turn out of the hogbacks. I continued on to Cheyenne.

As *Yankee Boy* headed in over Southern California, I sighted March Field. The Lake Norconian Club appeared over the left wing tip and shortly later the Los Angeles City Hall appeared to the right. Then came the University of Southern California campus, and in another few minutes we were crossing Municipal Airport.

Home again!

## THE REAPER

(Continued from page 31)

characteristics of these guns are as follows:

Total length	6 ft. 9 in.
" weight	114.4 lbs.
Rate of fire	400 rounds per min.
Weight of cartridge	340 gr.
" " link	35 gr.
" " projectile	173 gr.
" " explosive charge	17 gr.

The projectile is equipped with an extremely sensitive contact cap and is set to explode automatically after ten seconds, in case of a miss.

The rear section of the fuselage consists of a gunner's post completely enclosed in a streamlined transparent turret tapering to a point. This turret contains a 7.9mm. machine gun and is so mounted that it can be rotated in any direction within the field of fire.

The tail arrangement of the G-1 permits the gunner to fire downward to the rear, thus eliminating the blind spot usually so fatal to conventional two-seaters. Well sheltered from the wind stream in his glass inclosure, the gunner is able to swing his weapon with the greatest ease and to fire with the greatest accuracy.

The G-1 may be adapted to a variety of uses. As a pursuit plane, equipped with the above-mentioned armament plus eight hundred and eight pounds of bombs, it hits a maximum speed of 291.87 m.p.h., has a range of 869.4 miles. With the same equipment, the ship makes a formidable ground-attack plane. For reconnoissance use, the two cannons in the nose may be removed, thereby materially increasing the fuel load.

Provision is made for installing photographic apparatus in the rear cockpit. The great speed of the G-1, plus this increased range (993.6 miles) permits strategic reconnoissance over an extended territory and lessens the ship's vulnerability to antiaircraft guns and hostile planes. Used as a light bomber, the ship will take a fuel overload of four hundred and forty pounds. This increases its range (with 880 lbs. of bombs) to 931.5 miles.

Tony Fokker's new baby is no child to fool around with. It can match ninety per cent of the newest single-seaters when it comes to speed and maneuverability and is more heavily armed than any small plane I know of. The addition of a rear gunner not only makes the ship that much more formi-

dable, but also relieves the pilot of much of the wireless and instrument work that distracts the single-seater pilot from his real job of fighting.

There's no doubt of the military efficiency of the *Reaper*, despite its unusual features.

### Specifications and Performance

<b>DIMENSIONS:</b>	
Span	54' 1 <sup>1</sup> / <sub>2</sub> "
Length	33' 0 <sup>1</sup> / <sub>2</sub> "
Height	11' 5 <sup>1</sup> / <sub>2</sub> "
Area (lifting surface)	384.274 sq. ft.
<b>ENGINES:</b>	
Best altitude	11,480 ft.
Maximum power (2,400 r.p.m.)	2X750 h.p.
Cruising power (1,900 r.p.m.)	2X375 h.p.
<b>SPEED:</b>	
Maximum (11,480 ft.)	291.87 m.p.h.
Cruising (11,480 " )	217.35 " "
<b>CLIMB:</b>	
3,280 ft. (1,000 m.)	1.6 min.
6,560 " (2,000 " )	3.25 "
9,840 " (3,000 " )	4.8 "
13,120 " (4,000 " )	6.3 "
16,400 " (5,000 " )	8.05 "
19,680 " (6,000 " )	10.3 "
22,960 " (7,000 " )	13.4 "
26,240 " (8,000 " )	18.1 "
Absolute ceiling	30,504 ft.
Service " "	29,520 "
Absolute " (1 engine)	16,728 "
<b>WEIGHTS:</b>	
Empty weight	6,613.8 lbs.
Useful load	3,086.4 "
Wing loading	25,192 lbs./sq. ft.
Power loading	6.5 lbs./h.p.
<b>RANGE:</b>	
Pursuit	869.4 miles
Light bomber	931.5 "
Reconnoissance (maximum)	993.6 "

## THE 1936 MULVIHILL WINNER

(Continued from page 44)

boom to the stick at the indicated angle, the elevator will have the correct setting. Cement it to the boom after it has been covered. If you want to check this setting, the leading edge of the elevator should be about  $\frac{3}{16}$ " below the trailing edge. This setting is taken with the top of the motor stick as the reference line. The rudder is cemented atop the elevator. The part of the rudder directly above the elevator is left uncovered. The sheet-balsa part of the rudder is cemented to the bottom of the tail boom.

### PROPELLER

Luckett used a hard balsa propeller. If this is your first large propeller, you better substitute a medium-hard balsa block. Being easier to carve, it will give you experience before you tackle the more difficult hard-balsa propeller. The block is shaped as shown in the drawing. And then the blades are cut. About  $\frac{1}{8}$ " camber is put into the rear face of each blade. The maximum blade thickness is about  $\frac{1}{8}$ ". The hub of the finished propeller is about  $\frac{1}{4}$ " thick. The

height at the hub is about  $\frac{3}{8}$ ". The excess wood at the hub is cut away after the blades have been cut to the desired thickness. The type of freewheeling is a spring-and-catch type. However, your favorite variety can be easily substituted. Three or four  $\frac{3}{16}$ " washers are used between the propeller and the thrust bearing. Washers are cemented to the hub of the propeller to protect it against wear. The propeller is given 2 degrees negative and 2 degrees right thrust. Merely adjust the thrust hanger to get the required angles.

### FLYING

The model is powered with 16 strands of  $\frac{1}{8}$ " flat, brown rubber. About 5 inches of slack are used. The rubber will take about 720 turns. The model climbs in tight right circles and after the power cuts out, eases into a wide right circle. An estimate of the model's climb is 225 feet under power, in calm, current-free air. The propeller run is about 55 to 65 seconds.

Bruce lost his original model out of sight at 41m and 41s. But he made a duplicate for the purpose of illustrating

this article. He took it out for a few test flights, to make sure he hadn't lost his touch. And he hadn't—it flew out of sight on one of its test flights. But he had neglected to take photos, so he built another ship. Wisely, he took photos before making any test flights. But when I asked him for a detailed list of weights for the article, he wrote despondently that a short time after he took the photos, he took the ship out for a few flights and—you know the rest of his story. He lost it high in the clouds.

It was Luckett's skill in building and flying which won the trophy. Yet he graciously acknowledges that he drew from the common storehouse of knowledge which accumulated from the experiments conducted by his fellow club members. We'd like some of the material in this storehouse of model knowledge. With it, success in contests should be easy. Last year the Tulsa boys proved they had developed a formula for winning contests. The complete assortment of trophies and prizes they took home from every meet is the evidence.

## MODERN MOTORS

(Continued from page 34)

The whole valve gear (marked No. 25) is in the nose section and all moving parts are inclosed. Tulip-type inlet valves are used and the exhaust valves are hollow-stem sodium-cooled. There are two springs to each valve.

The crank shaft is made up in 2 pieces and is known as the clamp type. It is made from chrome-nickel molybdenum steel forgings. Somewhat similar to the master rod in the rotary engine is the master rod used on radial engines. This is mounted on the crank shaft in the same manner, and the link rods are connected to the big end ring by nitrided-steel knuckle pins.

This master-rod and link-rod arrangement in radial engines is probably the most difficult feature, for in designing the radial the engineer must consider the fact that he is first trying to place 7 or 9 cylinders in as compact a circle as possible. He must also consider the required number of cubic inches of displacement necessary to develop the required h.p. He then has to find some suitable ratio between stroke and bore to give him a cylinder of such a size and length that will fit all these points. Then he must design a crank shaft, master rod and link rods to fit this maze of steel and aluminium.

First, it is obvious that there is a certain piston limitation, for room must

be left to allow the full angular movement of the subsidiary rods at all piston positions. Thus the piston skirt must be designed to meet all these conditions. The same must be said for the lower walls of the cylinder itself.

Secondly, in designing the connecting-rod the engineer has to decide whether he will use a divided big end with a one-piece crank shaft or use a solid big end with a two-piece crank shaft. In the former, a one-piece crank case can be used, thus avoiding a joint in the center, whereas, in the latter a split case is a necessity, excepting in rare cases.

Some divided cranks suffer from oil leakage and often provide faulty non-interchangeable fittings. However, manufacturers like Bristol, Pratt & Whitney, and Wright, seem to have little trouble with divided cranks in which the single, overhung crank can be made sufficiently strong enough for the duty involved and at the same time provide a second forward bearing for the propeller support.

Once the designer has decided on the type of master rod construction, he is then faced with the problem of locating his link pins. While the crank shaft is revolving, the master rod follows a normal, connecting-rod path, but the subsidiary rods have a peculiar motion and a careful study of their positions at all

piston positions must be made. The pistons must all come to the proper top center at the proper angular interval passed through by the crank pin; the stroke of each piston must be the same; and for production and other reasons the length of each link rod should be the same. In order to obtain this, in spite of the peculiar motion of the rod, it is necessary to locate the knuckle pins at slightly different radial distances from the center of the master rod bearing with the angular spacing equal. This variation in distance may not be greater than eight hundredths of an inch, but it bears an extreme importance on the smoothness of the engine.

So we see that while the radial engine to-day has many fine qualities, it is still a most complicated mechanism. The crank-shaft, master-rod and the link-rod systems demand the finest in mechanical design, care in assembling and the selection of materials. However, at the present, the radial is probably the most efficient power plant for aircraft duty.

The radial is undergoing many changes. We cannot foresee what lies ahead. The designers are attempting many things with the radial design. We have seen what can be done with the so-called two-row engine and what enormous power can be obtained by the use of superchargers and high-compression systems.

Abroad they are still trying out the sleeve-valve radial. The Bristol "Aquila" and "Perseus" radials have been tried out under service conditions by the Imperial Airways, 4 of them being placed in use for a total of 1,505 engine hours, during which no maintenance of any sort was necessary.

The sleeve valve is not particularly puzzling, for it has been in use, off and on, in the automobile industry, for many years. In general, it comprises a cylinder having the intake and exhaust ports near its head, a piston-inclosing cylinder movably fitting within the main cylinder, which acts as a valve and which is fitted with exhaust and inlet ports. In ordinary motion, the inner, movable

cylinder or sleeve is timed to move up and down and register its exhaust and intake ports with those in the side of the main cylinder wall. This eliminates all outer valve equipment, and, in an aviation engine, naturally presents a particularly clean outer appearance.

In operation the condition of the sleeves improves with use and the oil consumption becomes less, which is an important point in commercial aviation. The fuel consumption is substantially lower than for corresponding engines employing the ordinary valve system. Cooling and cowling problems are considerably simplified by the clean and uncomplicated external design. Low exhaust temperatures, which seem to be a feature of sleeve valves, and the absence

of all external valve gear add to the quietness of operation.

Besides the sleeve-valve idea the radial is also being considered as a basic design for the compression ignition, or Diesel type. Bristol, the Czechoslovakian Zed-260, the French Clerget and the American Guiberson firms are all working on radial-type Diesels. The Guiberson Engine Co., in Dallas, Texas, is working under government orders and in strict secrecy, developing a Diesel for service work. Charles L. Lawrence is likewise experimenting on Diesel for aircraft.

Next month we will offer details and full information on the modern Diesel engines which are being designed for aircraft work.

## DESIGNING TO MEET NEW WAKEFIELD RULES

(Continued from page 60)

length and in this way increase the duration. With such a set-up, it would be necessary to use a slack rubber device such as Judge used in his 1936 Wakefield winner. This slack rubber device prevents the motor from unwinding completely—keeping a few turns in the motor and preventing the slack rubber from moving backward or forward to change the balance of the model.

The weight of the model could be kept as low as 3 ounces, with careful construction. This gives a rubber allowance of 5 ounces. Using 20 strands of  $\frac{1}{4}$ " flat rubber the motor length could be made 55 inches. The average rubber length on 4-ounce models is about 30 inches. Thus, with an 8-ounce model the rubber length could be practically doubled and still keep within the weight.

This increase in rubber length means the number of turns can be increased. The additional length will more than compensate for the  $\frac{1}{2}$  decrease in the number of turns which can be stored in a unit length of a 20-strand motor.

An adjustable pitch propeller would be an attractive addition to this type model. 20 strands of  $\frac{1}{4}$ " rubber delivers such a variation in torque that the propeller should be of variable pitch to make the most of the power. An adjustable pitch propeller can be made to produce a steady, uniform climb up to the last few turns.

J. B. Allman, who won the Wakefield trophy back in 1934, demonstrated an adjustable pitch propeller at Detroit last summer. His model turned in a nice 3-flight average of 2:43.3 to place 5th. His model was equipped with gears, in addition to the variable pitch propeller. This combination produced a propeller duration that was probably the best.

Last May, in England during the elimination contest for the Wakefield contest, Allman turned in a 3-flight average of 4m 28.3 seconds and won

first place on the English team. I saw his ship in flight at Detroit. It flew like a large airplane. It climbed nicely after a short take-off run. The usual zoom and vertical climb that accompanies a fully wound model was missing. The flight was steady and at the climb was uniform and continued throughout most of the flight. The fixed pitch propeller does provide a tremendous rate of climb under full power, but it does this at the expense of efficiency.

But efficiency is not the only consideration. An 8-ounce model is not as maneuverable as a light-weight model. For that reason the most efficient flight will be the one in which the plane never gets into any bad attitudes. The recovery from the climb must be accomplished without any stall or loss of altitude. Any violent maneuver during the beginning of a flight will result in either a crash or a short flight. It's unlikely if the model can recover from a stall and still have enough power and altitude remaining to give a good performance. The variable pitch propeller should help smooth out this initial burst of power and give the model a steadier and more efficient climb.

And now for the attack on the problem of reducing the sinking speed. One possible solution would be the use of some auxiliary lifting device which would take effect after the motor had unwound. This increase in lift would reduce the velocity of the model in the glide and reduce the sinking speed. A suitable lift-increasing device is difficult to devise. A trailing-edge wing flap is the only possibility. One suggestion is to have an adjustable strip of balsa along the trailing edge of the wing. It should be used with a low-camber-wing section. This section would show minimum drag under power and for the glide the balsa flap could be lowered a slight amount to give an airfoil shape which

would be more efficient for gliding conditions. But experiments seem to indicate that such a flap is of doubtful value. And, too, its installation would involve a method of lowering. Its contribution to reduced sinking speed hardly justifies using it.

The only other approach toward the problem of a lower sinking speed is to clean up the model by using a folding propeller and a retractable landing gear. This decrease in resistance would flatten the glide. And since the velocity in the glide would remain the same the sinking speed would benefit. With a slower sinking speed the model would be more sensitive to thermals. And despite the increase in weight ruling, thermal currents will still exert considerable influence on contest results.

From calculations and experiments we've concluded that a single motor without gearing is the ideal set-up. Its duration is good; it is simple to handle in contests; and it can be relied on to turn in consistent flights. Gears, considerably to the weight of the model, which necessitates reduction in the amount of rubber or imposing a handicap on your model by building above the 8-ounce minimum requirement. Then, too, there's always the danger of gears failing during the contest. A 20-strand motor delivers a powerful force, especially if your trying to crowd in capacity winds. In the strain of contest flying you usually are not able to give the model the careful attention it should have. And any such negligence would be likely to eliminate a geared model from competition before it would prove damaging to ungeared type.

It will be interesting to watch the technique used by the different designers in building an 8-ounce model. I'm convinced of the ability of American modelers to devise some way of bringing the Wakefield back to this country.

# MILES MOHAWK

(Continued from page 58)

Mount the small tail wheel either free to turn or permanently attached by a pin.

## PAINTING THE MODEL

Give the entire ship a coat of white shellac or clear varnish, to fill the pores and sand, after due allowance has been made for drying. Repeat the process as many times as thought proper for the finish. Paint the fuselage and landing legs black and the wings and tail surfaces orange, using one or more coats as desired. Striping, orange on the real

ship, is done with the aid of masking tape if best results are expected.

## BILL OF MATERIAL

1 6x1x $\frac{3}{4}$ " balsa block  
1 2x $\frac{3}{8}$ x10" sheet or block balsa  
1  $\frac{3}{32}$ x2x6" sheet balsa  
1 scrap of  $\frac{1}{4}$ " sheet  
1 pair  $\frac{1}{2}$ " wheels  
1  $\frac{1}{2}$  oz. bottle cement  
1 small can clear varnish or white shellac  
1  $\frac{1}{8}$ " dowel  
Pins and paints as required

# THE MODEL WORKSHOP

(Continued from page 41)

thought it would be interesting to increase the wing area of the model after the propeller stopped. You'll probably dismiss this idea. But just mention it to a gadget expert. After a few minutes' serious thinking, he'll sketch a method for increasing wing area. It will probably be a maze of triggers, springs, and automatic levers. But to the gadget expert it represents the real thrill in modeling.

The indoor builder is probably the most peculiar of all types. He quickly develops a weight mania. All his modeling hours are haunted by the specter of the scales. Its cold-blooded accuracy determines the success of his model. As soon as each part of a new indoor ship

is completed it is put on the scales. Nervously, the modeler moves the weight out along the beam. If the beam balances a few thousandths of an ounce less than he planned, he's successful. But it's a disgruntled modeler who walks back to the workbench with a part that is a few thousandths overweight.

But this quest for reduced weight has brought remarkable progress. Likewise, all of the other types of builders are responsible for equally important developments. With different technique and varied objective, each strives toward his goal, adding his portion to the general fund of knowledge.

# DOUBLE-SURFACED TRACTOR

(Continued from page 54)

3 preceding wings: namely, the tendency to floppiness, and the poorer wing of the original monospar.

## WING

The swept-forward elliptical wing consists of a main spar and a light leading and trailing edge. The wing is constructed as follows: Pin the  $\frac{1}{20}$ " sq. leading and trailing edges on a full-size drawing. Cement the upper ribs in place. When this is dry cement the

main spar of the center section in place (seam on bottom). The main spar is made by bending a blank of  $\frac{3}{4}$ x1 $\frac{1}{2}$ " 4-pound balsa  $\frac{1}{64}$ " sanded, around a former  $\frac{1}{4}$ x $\frac{1}{8}$ x1 $\frac{1}{2}$ " edges rounded. Cement the dihedral in the tip sections and add main spars of  $\frac{1}{20}$ " sq. to the tips section. Cement the lower ribs in the places designated on the drawing by dotted lines. The wing is now ready for covering.

The top is covered first. It should be

covered in one piece. However, if this is not possible, the center section may be covered first and the tips afterward. The lower surface may then be covered easily. The clips are of the double type, in order to distribute the stress. This is necessary, as the spars to which they are attached are so small. They should be cemented into place after the film has been trimmed. The wing is then completely finished.

As a chief object of the wing is to test its efficiency, it would be ideal to fly it on some suitable model you now have, in order that its performance might be compared. However, if no model is available, the tail, motor stick, and propeller, which will be described, will be suitable. You may draw your conclusions from general performance of models of this size. Or you might build a conventional wing to fit the model and make your comparison on that basis.

## MOTOR STICK AND BOOM

The motor stick is built in the conventional way. A blank 1" tapered to  $\frac{3}{4}$ x14" of  $\frac{1}{32}$ " balsa is bent around a former, bound with tape, and dried over a radiator or in an oven. After removing the bandage, and the formed blank from the former, cement the seam and sand the stick lightly. Cement the thrust bearing, rear hook, and can in place and let dry.

The boom is made of  $\frac{1}{64}$ " balsa blank  $\frac{5}{8}$ " tapered to  $\frac{3}{8}$ " and 10" long. It is made in exactly the same way as the motor stick and is cemented to it so that the rear edge is  $\frac{1}{8}$ " above the front.

## TAIL AND RUDDER

The tail and rudder are single-surfaced, as we are testing the efficiency of the wing and, therefore, it is only fair that they be single-surfaced so that the results of the test might be compared fairly.

The tail is made in two halves. Make a cardboard template of the rudder and half the tail. Bend strips of soft balsa  $\frac{1}{20}$ x $\frac{1}{32}$ " around these formers, one for each half of the tail and one for the rudder. Pin the outlines down to a full-size drawing and cement the ribs into place. Cover the tail and rudder and then cement them to the boom, making sure that the tail and rudder are perpendicular to each other and that the tail is parallel to the center section of the wing.

## PROPELLER

Any propeller 15 inches in diameter and between 24" and 30" pitch would be suitable. If you do not have one, or cannot beg, borrow, or steal one, you might carve one from a semicarved blank 15 inches in diameter and the pitch diameter ratio of 1.6. If you wish to carve a block, one—of the dimensions of 15x1x1 $\frac{3}{4}$ "—should do the trick. A shape similar to that of the full-size

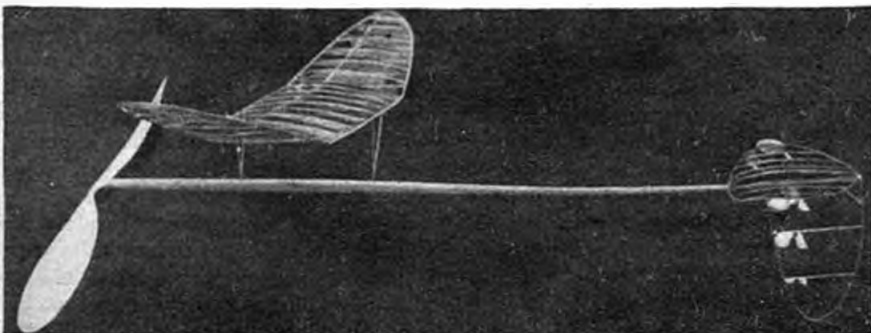

Side view of the model clearly shows the design and construction features.

drawing should be used. Fit the propeller with a wire shaft .016" in diameter and with a brass washer. It is important that this propeller be balanced and that it track. Any tendency to erratic flight uses energy and makes the test unfair.

### ASSEMBLY AND FLYING

Insert the propeller shaft into the thrust bearing, and as the total weight of the model is about .060 ounces put a 20" loop of  $\frac{3}{32}$ " rubber on the rear hook and shaft and balance the model without the wing. Place the 40 per

cent chord point of the wing at the center of gravity and glide the plane. The model should glide well. If it has a tendency to stall, move the wing backward; if it has a tendency to dive, move the wing forward. Wind the model about 500 turns and release it. If it has a tendency to stall slightly at the start, bend the thrust bearing downward. Increase the winds to a 1,000 and repeat the treatment if necessary. Wind the model to almost full capacity and release it. If it now has a tendency to dive, bend the thrust bearing up somewhat to correct this.

After the model is correctly set the

tests should begin. Comparative tests on rate of climb, ceiling, and power required, and whether or not the speed of the model seems to increase should be noted. Remember, however, that the test of one wing is by no means conclusive, as there are many facts which have some bearing on the results but have not been considered, such as the difference in the weights of the double- and single-surfaced wings.

I should be glad to exchange ideas and to hear of your results and opinions of your models of this type and otherwise.

## AIR PROGRESS

(Continued from page 7)

to know that the New Zealand air force is to be thoroughly reorganized under the direction of Wing Commander R. A. Cochrane.<sup>1</sup> The process will take about 2 years.

U. S. army air force airmen have been bombing Hawaii—with bombs containing tree seeds.

The 27th and the 94th Pursuit Squadrons of the First Pursuit Group are having their Curtiss and Boeing fighters replaced by the new Consolidated PB-2a, which, in their present form, are two-seaters. A single-seater version of this same ship has also been built and is under test. This is one of the first moves toward making two-seater fighter squadrons out of single-seater outfits.

### RACING AND RECORDS

It has been reported that Miss Jean Batten spent \$11,000 on her flight from England to New Zealand. Her South

Atlantic record of 13 hours 15 minutes was broken recently by Mlle. Maryse Bastie, a young Frenchwoman who covered the distance in 12 hours 5 minutes. Mlle. Bastie used a Caudron *Simoun*, which was loaned to her by M. Cot, the French Air Minister.

Howard Hughes, who broke the air record for flight between Los Angeles and Newark, averaged better than 5½ miles per minute. His plane is not the same as the one he used for the former speed flights, for it has had a new set of wings fitted, which gave more lift and better streamlining.

David Llewellyn, the British air racer, plans to fly from London to Capetown and return in 4 days.

The latest model Wright Cyclone G-100 motor is rated at 1,100 h.p. and has actually turned out 1,205 h.p. from 9 cylinders.

### MISCELLANEOUS

The Herbert Schiff Memorial Trophy was won this year by VN Squadron 8D5, which is attached to the U. S. Naval Academy. The trophy was presented to Lieut. Comdr. A. C. McFall, the squadron commander, by President Roosevelt, at the White House, on January 14th. The express purpose of the donor was to stimulate interest in naval flying and at the same time to reduce aviation accidents.

VN Squadron 8D5 is maintained for the training and indoctrination of midshipmen in connection with the general subject of aeronautics and is composed of the patrol and seaplane types. To win the Schiff trophy the squadron flew a total of 4,154 hours and was in competition with 82 other naval aviation activities.

## TRAGIC MEMORIAL

(Continued from page 38)

Verne. One spot on the lot is dedicated to the dream of an impractical inventor who managed to raise \$60,000 to build a helicopter. At first glance it resembles an oil derrick, with a train of huge steel gears. This weighty structure was powered with a 100 h.p. engine with which it was expected that the entire mass could be lifted vertically into the air. On the test flight the engine failed even to move the structure and the backers practically made a gift of it to Balboni.

In his collection of propellers may be found a hand-carved propeller used by Glenn Curtiss in his early experiments. This one was carved from a single piece of wood and was driven by a motorcycle engine; the engine also is in the engine shed. World War pilots get a thrill in rambling among the wrecks, for they find old war-time Spads, Jennies, Thomas Morse Scouts, Nieuports, and DHs.

Not all of the equipment, however, is

the result of crash or wreck. There are obsolete types and equipment in fairly good condition purchased by the proprietor for their historical value. Two of the motors which Balboni prizes are those used by Glenn Martin in the first air meet in 1910. Another is the motor of Captain Charles Nungesser of the French Army, an ace who was later lost in an attempt to fly the Atlantic. This motor powered a plane which Nungesser used in shooting down eight enemy aircraft.

It is only natural that the man who has dissected more wrecks than any other man in the world should evolve certain theories regarding crashes. His most interesting theory seems to be substantiated by the little evidence that is known. Balboni's theory is that in the event of a crash men invariably lean backward, while women do just the reverse. Men will brace their feet, while women do not. In looking over a large

pile of seats, of which the history was known, the seats occupied by men were bent backward and those occupied by women were bent forward.

Balboni's customers come from every walk of life and from every field of endeavor, but naturally the greater number are pilots and embryo aeronautical engineers. He furnishes equipment for groups constructing gliders, planes, and so forth; museums and collectors are continually poking around his plots and buildings looking for valuable additions to their collections.

In his effort to maintain the atmosphere of his business, he has constructed the main building on his property from an old Clover Field hangar. On top of this building he has constructed a penthouse where he and Anna live in peace and quiet, surrounded by the ghosts and shadows of gallant men and the skeletons of ships.



# THE DISCUSSION CORNER

(Continued from page 56)

I believe that the best possible color combination for an all-weather outdoor model is red and yellow—a red fuselage and tail assembly and a yellow wing. Yellow is a light color, therefore a very good reflector, especially when doped. Red is a color that very seldom blends with the sky, hence it tends to be conspicuous. At a great distance, a red-and-yellow model can be kept in sight more easily because of these two factors. As a model of these colors circles in the distance, it will appear as a minute black speck and then, just when you think you must have mistaken your model for a bird, it will come around into the light and can be easily identified by a brilliant reflection. Due to the fact that I have been using red and yellow on my models for quite some time now and in all types of weather, I have found that these colors will hold good.—PAUL JOHNSON, Tulsa, Oklahoma.

Most builders favor colors such as black, red or blue, but I would say that silver or aluminium would give the best results. Above altitudes of 300' these rich colors lose their individuality and appear only as black. This is due to their inability to reflect sufficient light beyond such heights.

Aluminium has the greatest reflecting power of any practical model dope and would flash and sparkle at heights up to several miles. We all know that a highly polished prop is readily seen while free-wheeling at 1,000'.

Silver is the only color that does not appear in any kind of foliage and thus, models lost in the woods could be easily distinguished among green or orange bushes, leaves and trees.—JOE BLOOM, Roxbury, Mass.

The best color scheme on an all-weather outdoor model is a dark-blue fuselage and bright-red or yellow wing and tail surfaces. Models with this color scheme are very attractive and are very easily seen. The dark-blue fuselage shows up against light-colored backgrounds and the bright red or yellow against a dark-colored background. In winter both colors show up with striking contrast to the white snow. This color scheme is very effective for gas models. These colors also show up remarkably

well in photographs and snapshots.—ERLEND ANDERSON, Duluth, Minn.

The use of "every color of the rainbow" is the best color combination on an all-weather outdoor model, for greatest visibility. Many models have been lost from the timer's sight during flying contests because the colors of the model resemble their background so greatly that they are not distinguishable.

To overcome this, I have found that it is best to divide the wing into four parts and cover every other part with a dark color and the remaining parts of the wing with a light color. The fuselage and the rest of the wing surfaces may be covered in similar manner.—WALTER CARACCILO, Jackson Heights, Long Island.

In my opinion the best color scheme for an all-weather outdoor model would be a dark blue or black for fuselage with bright yellow, orange or red for the wings and tail assembly.

It is rapidly becoming a hazard to compete in a model meet (gas models especially) for fear of losing sight of your model, just because the colors were too light.—MALCOLM SMITH, Minneapolis, Minn.

I have obtained satisfactory results from the use of colored tissue on outdoor models. The combination of red, white and yellow can be seen in any weather. Models covered with colored tissue are visible because the sun shines through the paper. The color combination that I use is a red wing and rudder, a white fuselage and a yellow stabilizer. As to the strength of colored tissue: it

seems to me that colored tissue is strong enough if the grain runs spanwise. Besides the advantage of visibility, models covered with colored tissue present a neat appearance.—PETER SLAP, Far Rockaway, N. Y.

In my opinion, the best colors to keep a model within sight for the greatest time are as follows: the lower part of the wing should be red, which makes for good visibility on a clear day, when a model is banked against clouds or sky; the tail should be white, which is more easily seen on a dull day; a bright yellow is a good fuselage color, since it is easily visible and aids appearance; the top of the wing should be white with a red stripe or chevron. This enables the model to be more easily located after landing.—EDGAR FRANCIS, New Castle, Pa.

I have discovered that red is the most visible color to the normal eye, but this color alone would not always suffice, since a model does not only require a color that is most visible, but in some instances requires a color that is least fatiguing to the eye, and that color I have found is green. For gray skies, such as appear during twilight, blue would be most easily visible.

Therefore, the best and most logical color combination would be red and green, and blue, if necessary. Red for its excellent visibility to the eye; green because of its restful effect on the eyes; and blue, if necessary, because of its excellent visibility against a gray sky.—CHESTER KIEWLAK, Shenandoah, Pa.

Out of several color combinations I have chosen those that I believe would be the best for all-weather visibility. One combination has its foundation in everyday life. Most signs, highway warnings, center-line markings, and others are either black or bright orange. To combine these, I would cover the fuselage black, with orange wings and with a streamline trimming along the fuselage in orange tissue. Another combination would be to cover the fuselage with yellow tissue and with red wings. I would also trim the propeller, landing gear, and the other fittings in silver and black.—LLOYD COOPER, Collinsville, Illinois.

## December Contest

The following readers were winners in the December "Gullible's Travels" contest with the indicated number of allowable errors:

First prize, \$5—Bernie Musur, Argo, Illinois, 100.

Five prizes of \$2—James Conway, Waterbury, Connecticut, 96; Ray L. Meyer, Louisville, Kentucky, 93; Harvey Hayes, Houston, Texas, 92; Francis Watyka, Johnstown, Pennsylvania, 91; Allan Down, Flaxcombe, Saskatchewan, Canada, 90.

Five prizes of \$1—Mike Pykelny, Cleveland, Ohio, 87; Edwin H. Hunt, Brooklyn, New York, 83; Donald White, Oakland, California, 81; John Welasch, Chicago, Illinois, 79; Orville Smith, Wenonah, New Jersey, 78.

NOTICE!

Items for Secretaries, Contributors, Modelers, Correspondents, Readers. MODEL DISCUSSIONS, MODEL MATTERS, CONTEST CALENDAR, AIR ADVENTURERS DEPARTMENT.

Due to the increasing number of entries mailed to the various departments, it has been necessary for us to set a definite date as a dividing line between issues. This date is the 15th of each month. Try to get your notices and announcements to this office before the middle of each month.

For Example: All items received by March 15th will be in time for the June issue of AIR TRAILS, on the newsstands May 12th. All items received between March 16th and April 15th will be available for the July issue, on the stands June 9th.

Please bear the date in mind. We want to cooperate with you. Try to cooperate with us.—The Editor