

# MODEL AIRCRAFT



Another  
M.A.  
Exclusive  
Feature!

**The TIGER MOTH**

SIX PAGES OF  
COMPLETE DRAWINGS  
PHOTOGRAPHS AND DETAILS

**1/6**

MARCH 1957



SAY

# Skyleada

NOTE TO RETAILERS  
Modellers everywhere are  
now insisting on "SKY-  
LEADA" branded Balsa  
because of its consistent  
high quality. Write for  
list at VERY competitive  
prices.

FIRST

## For BETTER Value in Model Aircraft Kits

JUST LOOK AT THE BIG WING-  
SPAN of these Rubber-Powered  
Models of Popular Aircraft you  
can build from Kits at only

**3/9** each Inc. P.T.

- 26" AUSTER
- 26" GRASSHOPPER
- 24" CESSNA BIRD DOG
- 24" PIPER SUPER CRUISER
- 24" COMPER SWIFT
- 24" PUSS MOTH
- 20" TIGER MOTH
- 20" HAWKER FURY
- 24" SHORT SEAMEW

and a  
**SAILPLANE GLIDER**  
32" SEAGULL

Series also includes  
**JETEX 50 POWERED**  
FOLLAND GNAT  
PERCIVAL JET PROVOST  
GLOSTER JAVELIN  
HAWKER HUNTER  
SUPERMARINE SWIFT  
D.H. COMET  
D.H. VENOM  
D.H. 110  
AVRO VULCAN  
AVRO 707A  
M.I.G. 15  
U.S. NAVY CUTLASS  
THUNDERJET  
MYSTERE IV  
SUPER SABRE  
SABRE F.86

NOW AVAILABLE FROM YOUR  
RETAILER

**36" SPAN HUSKY**

A DE LUXE KIT which includes a  
14" FINISHED Balsa PROPELLER  
An easy to build Duration Model with  
a really exceptional performance.

**12/9** inc. P.T.

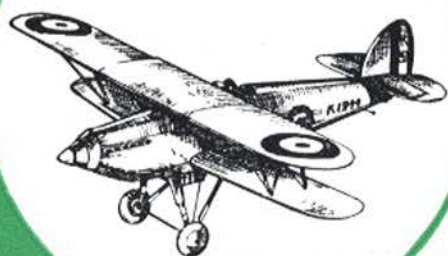

20" HAWKER FURY

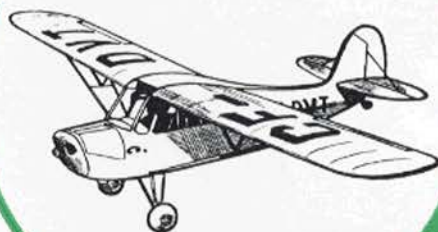

24" PIPER SUPER CRUISER

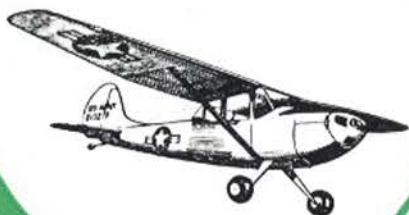

24" CESSNA BIRD DOG



20" TIGER MOTH



24" SHORT SEAMEW

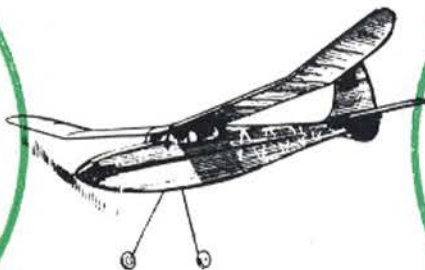

32" SEAGULL

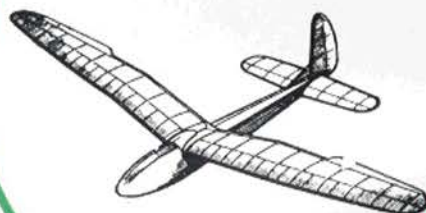

NOTE TO MODELLERS  
For better modelling insist  
on "SKYLEADA" branded  
Balsa and be sure of get-  
ting THE best.

Ask your retailer for a copy of the NEW detailed illustrated leaflet or send us a stamped addressed envelope. Note to retailers: If you have not already received a supply send a post card direct to us

**BRITISH MODEL AIRCRAFT MFG. CO. LTD.** 180 LONDON ROAD, MITCHAM · SURREY



AND A FEW MORE PLACES BUYING Balsa

AND EVEN IF I DID STAY LONGER THAN I SAID I WOULD



I DIDN'T COME BACK WHEN THEY EXPECTED ME TO!

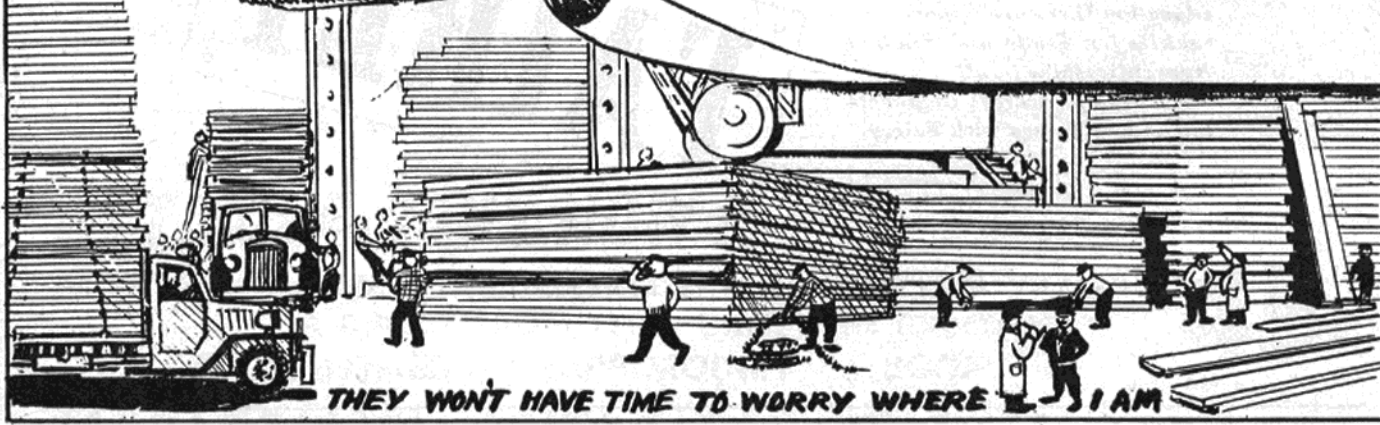
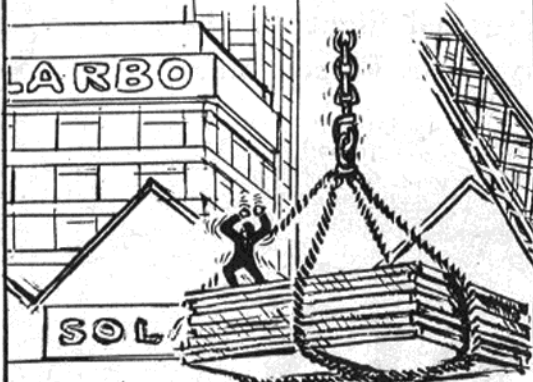

THEY WON'T HAVE TIME TO WORRY WHERE I AM



LTD · COMMERCE WAY · LANCING · SUSSEX

Telephone: LANCING 2866-7  
Telegrams: SOLARBO WORTHING

DIRECTORS: J.V. PATERSON A.M.I.C.E. · R.T. FULLER · H.N. PELMOORE

"Has anyone seen John Paterson"? So what! What a fussation! What a to-do! Simply because I didn't come back when they expected me to!

Why couldn't they keep quiet about it? Now, everybody sniggers when I say I have been abroad buying Balsa!

Well, I have been buying Balsa and even if I did stay longer than I said I would - that's my business!

I'll show them whether I have been buying Balsa. There will be so much B—B—B—Balsa coming into this works that they won't have time to worry where I am!

I've been to Ecuador buying Balsa, and to a few other places buying more Balsa, and that's the end of it.

*John Paterson*



# MAKE AIRCRAFT

*your career*

*Fairey's want young men  
with a keen interest in aviation*

At Fairey's, work progresses in every branch of aeronautical science. Beginning with Naval aircraft (with which the Company has been associated for over 40 years) Fairey activity ranges through rotary-wing development and high-speed flight to the production of guided weapons for the Royal Air Force. More engineers are needed in every section.

*Think things over; then write  
to the Apprentice Department  
of The Fairey Aviation  
Company. For young men  
with a good standard of  
education there are oppor-  
tunities for Trade and Student  
Apprenticeships in all  
branches of Aircraft Engineer-  
ing and—a future with Fairey.*

# FAIREY

APPRENTICE DEPARTMENT

THE FAIREY AVIATION COMPANY LIMITED, HAYES, MIDDLESEX



FIRST AERONAUTICAL WEEKLY IN THE WORLD

FOUNDED 1909



WEEKLY 1s. 6d.

The Editor draws attention to the cutting below from the current issue

Happy the lad who gets a copy of Bruce Robertson's *Aircraft Camouflage and Markings 1907-54*. The volume of data contained in its 212 large pages is phenomenal, and seldom have so many first-class informative illustrations been packed into a single book. Many are in full colour and the publisher has not even hesitated to use silver ink where appropriate to ensure complete authenticity. Mr. Robertson has included everything that one could wish for in such a book, and more besides. Camouflage schemes of British and foreign aircraft, from the F.E.8 of 1916 to the Firefly unmanned target of today, are shown in full colour, as are the current R.A.F. fighter squadron insignia. Line diagrams depict the R.F.C. squadron markings of 1917-18, the French, Belgian and the U.S. squadron insignia that pointed the way to the highly-decorative unit and individual aircraft markings of World War II (themselves covered in detail later in the book) and current world air forces insignia.

This huge collection of drawings and photographs is accompanied by no less comprehensive and painstaking editorial descriptions of how and why the various camouflage schemes and markings came about. A measure of the author's enthusiasm for his subject is that the appendices include complete lists of R.A.F. unit code letters 1939-45, serial number allocations 1912-54, the British non-rigid airships of 1914-19 and even the markings for British standard doping schemes of 1914-18. There are a few mis-spellings, mainly in the captions, but these are mere pin-pricks in a book that is a "must" for model-makers and every self-respecting aviation bookshelf.

*"Aircraft Camouflage and Markings, 1907-1954,"* by Bruce Robertson. Harleyford Publications Ltd., Harleyford, Marlow, Bucks. Illustrated. Price 45s.

This review, which appeared in the December 21st issue of "Flight," is reprinted by kind permission of the Editor of that magazine.

PUBLISHED BY ILIFFE & SONS LTD., DORSET HOUSE, STAMFORD STREET, LONDON, S.E.1

**GET YOUR COPY NOW!**

FROM ANY MODEL SHOP, BOOKSELLER

OR DIRECT FROM THE PUBLISHERS (Dept. MA/2)

THIS IS ANOTHER "HARBOROUGH" BOOK BY  
**HARLEYFORD PUBLICATIONS LTD.,**  
HARLEYFORD, MARLOW, BUCKS, ENGLAND

**45s**  
PLUS 2/-  
POSTAGE &  
PACKING



\* can you identify this

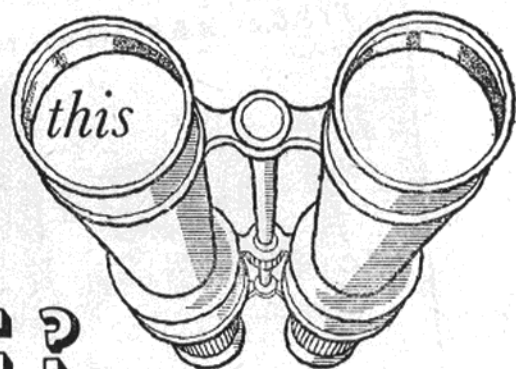

# LIGHT CABIN MONOPLANE ?



These rugged little aircraft can operate from tiny fields. Just now they are doing invaluable work spotting bandit hideouts in the Malayan jungle. If you join the Royal Air Force as an Apprentice (age 15-17) you could be a skilled technician servicing every kind of aircraft, from this type to the latest jets. Pay rates during training have *nearly doubled* under the new R.A.F. scale. For further details of an exciting career with a fine future, post the coupon below *now!*

\* One 180 hp. Blackburn Cirrus Bombardier engine . . . Maximum speed 127 mph . . . Cruising speed 110 mph. The Auster A.O.P.9 climbs at 920 ft./minute and has a range of 242 miles.

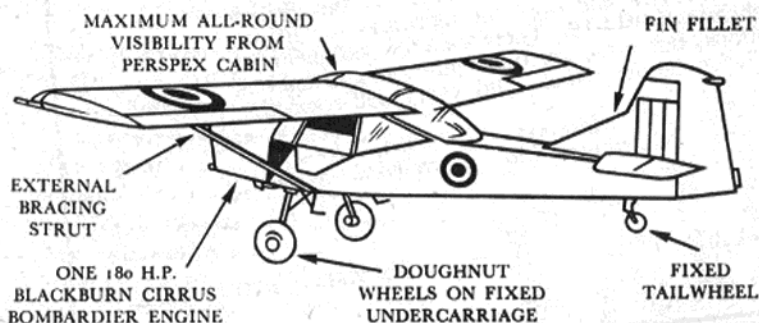

there's  
a career for  
you in the

# R.A.F

TO: ROYAL AIR FORCE (MAC 254a), VICTORY HOUSE, LONDON, W.C.2

I am over 14. Please send me details of entry for:

(A) The Apprenticeship Scheme

(B) The Air Training Corps.

(Tick which you require)

NAME.....

ADDRESS.....

DATE OF BIRTH.....

(Applicants from British Isles only)



# Tri-ang

Regd Trade Mark

## RADIO CONTROL

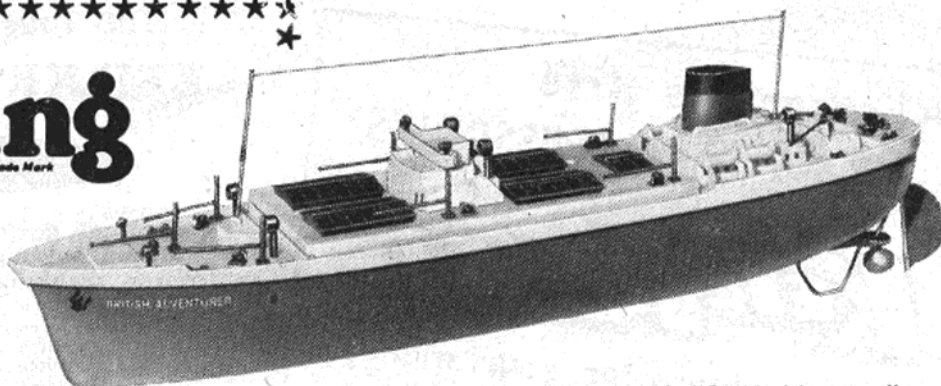

Quality is the keynote of the Tri-ang radio control models and components. Every part has been fully tested and proved by Tri-ang development engineers, and is carefully controlled and inspected at every stage to ensure absolute mechanical and electronic efficiency. Expert knowledge is not required either to operate the complete models or to instal the various individual units. They have been designed especially for the layman!

The Tri-ang radio controlled M.S. "British Adventurer" is 20 in. long, precision built, and a fine model of a large cargo ship. She is fitted with the Tri-ang "Radio-slave" and is, apart from fitting the batteries, tested and in all respects ready to sail. The rudder and main driving motor are controlled by radio. The former has three positions, port, midships and starboard whilst the motor speed may be varied, stopped or the ship made to go astern. Packed in a special container. M.S. "British Adventurer" complete but excluding MK.I Transmitter.

Retail price £9 3s. 0d.

M.S. "British Adventurer" complete with Tri-ang Radiomaster MK.I Transmitter.

Retail price £15 2s. 0d.

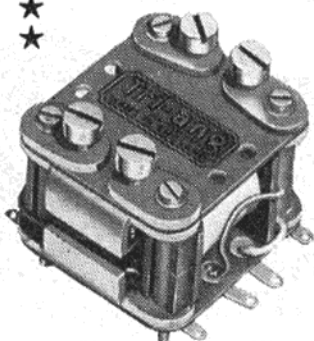

Price £1 8s. 0d.

### TRI-ANG DOUBLE-POLE SENSITIVE RELAY

World's first double-pole sensitive relay specially designed for model control. Double-pole change-over movement gives instant reversal for all types of reversible actuators, simplifies multi-control circuits and gives double security to single controls. Polarized. Immensely sturdy. Pre-set. Coil resistance 7,000 ohms. Balanced armatures. Size 1½ in. x 1½ in. x 1½ in. Weight 2 oz.

### TRI-ANG AIRCRAFT RECEIVER

Subminiature hard valve for long life. Double-pole sensitive relay for double security or more advanced circuits. Printed circuit. Large current drop. Totally enclosed in tough plastic case. Size 3½ in. x 2 in. x 1½ in. Weight including leads and plugs 4½ oz.

Price £4 0s. 0d.



### TRI-ANG MARK II RADIOMASTER

Crystal controlled carrier frequency. Under all conditions the Radiomaster will only oscillate at the spot-on frequency of 27.255 Megacycles per second. An adjustable tank circuit enables output to be matched to any aerial length used. Built in radiation and output indicator.

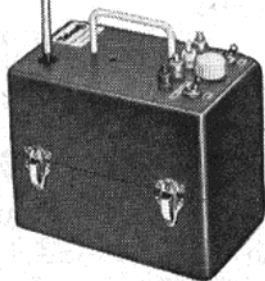

Built in electronic pulsing circuits with continuously variable Mark/Space ratio from approx. 1:10 to 1,2:1. Two alternative and widely separated pulse frequencies. Built in filter circuit to eliminate TV. interference. Without aerial rods assembled the Radiomaster emits a weak test signal on the correct frequency, thus enabling the Receiver in the model to be accurately tuned without taking it some distance away from the Radiomaster. Size 8 in. x 4½ in. x 7 in. Price £6 10s. 0d.

Price £6 2s. 0d.

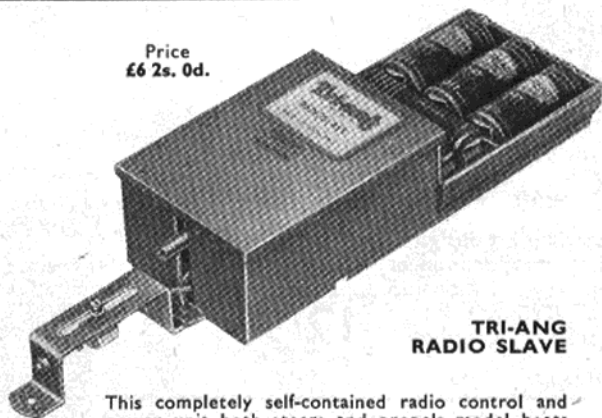

### TRI-ANG RADIO SLAVE

This completely self-contained radio control and power unit both steers and propels model boats up to 24 in. in length (including speed control and reversal by radio). Also steers boats up to 6 ft. Suitable for road vehicles and other models. Easily installed. Complete with hard valve receiver, battery compartment, actuator and power unit. Special attachment for positional steering control. Size 8 in. x 3 in. x 2 in. Weight 1 lb. 4 oz.

### TRI-ANG RADIOMASTER EXTENSION LEAD

For remote keying of Transmitter when controlling aircraft. Tough water-proof cable easily attached or removed. Price 9s. 11d.

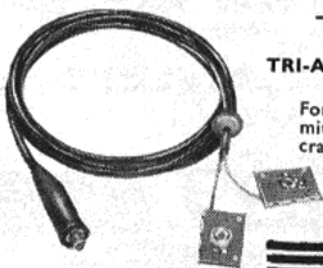



Whether it's **KITS**  
or **ACCESSORIES**

**KEILKRAFT**

gives you more for your money

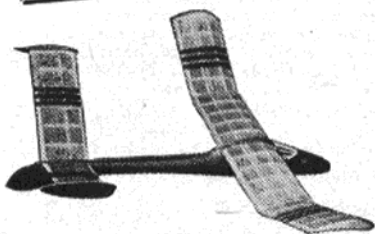

**40" SPAN TOPPER**

A contest glider of advanced design featuring butterfly tail, streamlined section fuselage, and tip dihedral for stable flight. The multi-spar wing with its undercambered airfoil section, is light in weight —yet strong and warp resistant. The kit contains full size plan, building and flying instructions, and ample high grade materials. The Topper is capable of an outstanding performance. **10/6**

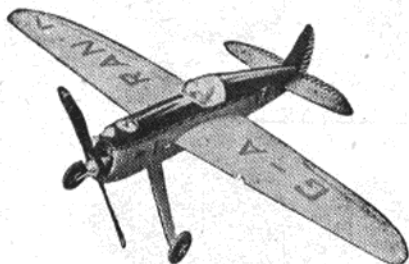

**24" SPAN RANGER**

The outstanding kit design for Class "A" team racing. Monocoque balsa fuselage. A fast, and rugged flier (up to 2.5 c.c.) As with all Keilkraft kits, contents are very complete. **12/9**

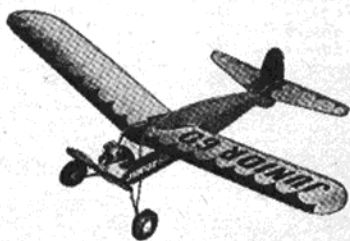

**60" SPAN JUNIOR 60**

Now redesigned and specially adapted for radio control, the Junior 60 is the easiest-to-build large power model on the market. It takes off and lands just like a full size plane, and has very steady flying characteristics. Although the winner of many important R/C contests, it is also the ideal Free Flight **54/-** model.

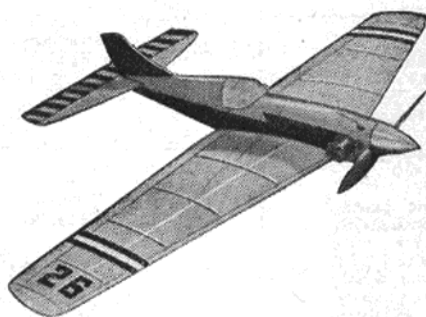

**SKYSTREAK 26**

**26" SPAN C/L STUNT MODEL**  
Sturdy model that does every stunt. Planked balsa fuselage, and detachable wing. For diesel motors from 1 c.c. to 1.5 c.c. **11/3**

The Toughest Prop Ever Made!  
**KEILKRAFT "TRUFLEX"**



The tough flexible plastic prop that will outlast a dozen wood props. Also prevents damage to motor crankshaft. In sizes to fit all motors.

6 in. dia. x 4 in. pitch ...	3/-	9 1/2 in. dia. x 4 1/2 in. pitch	4/9 1/2
7 in. dia. x 8 in. pitch ...	4/2 1/2	9 in. dia. x 8 in. pitch ...	5/1 1/2
8 in. dia. x 4 in. pitch ...	4/2 1/2	10 in. dia. x 8 in. pitch ...	6/-
8 in. dia. x 6 in. pitch ...	4/6	11 in. dia. x 5 1/2 in. pitch ...	6/-
8 in. dia. x 8 in. pitch ...	4/6	14 in. dia. x 6 in. pitch ...	12/9



**KEILKRAFT FUEL CUT-OUT**

Easy to fit  
Positive action

**4/9 1/2**

**KEILKRAFT RUBBER WHEELS**

Strongly moulded in best quality rubber. A "must" for all power model fans.



Sponge rubber streamlined type.	
1 1/2 in. dia. 3/-	2 in. dia. ... 4/2 1/2
Sponge rubber balloon type.	
1 1/2 in. dia. 3/-	2 in. dia. ... 4/2 1/2
Hard rubber streamlined type.	
1 1/2 in. dia. 1/6	2 in. dia. 2/5 2 1/2 in. dia. ... 3/7 1/2

**KEILKRAFT "SCREW-ON" PLASTIC SPINNERS**

The perfect finishing touch for your power model.

1 1/2 in. diameter ...	2/8 1/2
1 1/2 in. dia. 3/-; 1 1/2 in. dia. 3/-	2 in. dia. 3/7

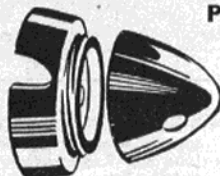

**MOTOR BOAT ACCESSORIES**

**RUDDER ASSEMBLIES**

With ratchet tiller adjustment  
Large or Small ... each 6/9

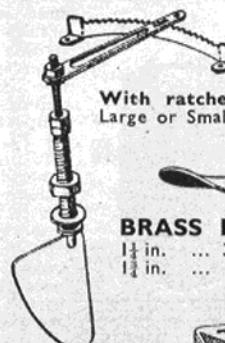

**BRASS PROPELLERS**

1 1/2 in. ...	3/5 1/2	1 1/2 in. ...	3/5 1/2
1 1/2 in. ...	4/-	2 in. ...	4/-



**BOAT FUEL TANK**

15 c.c. capacity  
5/5 1/2

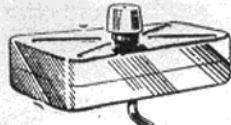

Ask your dealer to show you the complete range of K.K. marine accessories.

Now Available at your nearest Model Shop  
**1957 KEILKRAFT HANDBOOK & CATALOGUE. PRICE 1/3**  
or direct from E. KEIL & CO. LTD. 1/6 post free

Buy **KEILKRAFT** at your nearest model shop

If no model shop convenient order direct from **KEILKRAFT**. Please add 6d. for packing and postage.

E. KEIL & CO. LTD., WICKFORD, ESSEX



# MODEL AIRCRAFT

Managing Editor E. F. H. COSH

Assistant Editors

R. WESSON

N. J. BUTCHER

Consulting Editor  
A. F. HOULBERG

Advertisement Manager  
J. V. FORBES-BUCKINGHAM

MARCH 1957

No. 189. VOL. 16

## Contents

### Special Features

NEW M.A. BEGINNERS' COURSE Part XIII. Jetex Motors and Models	76
RADIO CONTROL NOTES ON RELAYS	81
ENGINES ONLY	83
TESTING RUBBER MOTORS	85
THE D.H. TIGER MOTH	87
IS EVERYTHING UNDER CONTROL?	93
MODEL QUIZ	95
SPACE SHIPS A'COMING	102
NEW BOOKS	102

### Regular Features

HERE AND THERE	72
TOPICAL TWISTS	80
AVIATION NEWSPAGE	96
ENGINE TESTS The Frog 80	98
OVER THE COUNTER	100
LETTERS	101
CLUBS	103
<b>Plans</b>	
CLANCY	74

### Cover Story

Easily the most popular light aeroplane ever built in this country, the *Tiger Moth*—after 25 years—is still to be seen flying in many parts of the world. Undoubtedly World War II prolonged the life-span of the "Tiggie," with many of the R.A.F. machines being released for private ownership.

Our cover, yet another fine Charles E. Brown photograph, shows G-ALND flying over Southampton Docks.



THE JOURNAL OF THE SOCIETY OF  
MODEL AERONAUTICAL ENGINEERS

Published on the 20th of each month prior to the date of issue by  
PERCIVAL MARSHALL & CO. LTD., 19-20 NOEL ST., LONDON, W.1.  
Telephone: GERrard 8811. Annual Subscription 20s. 0d. post paid.

## Letters

TO THE  
EDITOR

### Two into one

DEAR SIR,—Recent correspondence re the lack of 0.35 motors prompts me to offer a suggestion.

The requirements of the modeller in the 0.29 and 0.35 class of engines are for speed, team racing, stunt, combat, F/F, and R/C.

With these requirements in mind, the manufacturer must be prepared to think "big," and tool up his factory accordingly (or largely sub-contract out). His initial expenses will, no doubt, be high for new jigs, fixtures, dies, and inspection arrangements, but most modellers would be prepared to pay for quality.

The loop scavenger type of engine has proved itself to be the most efficient and fastest engine, is easier to cowl and duct out the exhaust gases and oil spray. From this let us consider the basic part, the diecast crankcase and cylinder barrel. This part can be set up and bored to take a 0.29 liner or a 0.35 liner. The stroke is the same for the two engines—0.718 bore  $\times$  0.718 stroke for the 0.29 and 0.788 bore  $\times$  0.718 stroke for the 0.35. A small additional machining operation will be required on the 0.35 by-pass to enlarge it.

The cylinder head is diecast and machined down to give a gas-tight fit for either liner, while the gudgeon pin and con rod—the latter forged—are common to both capacities of engine.

Two crankshaft and backplate assemblies to be available, one a plain front intake and plain backplate, and the other a twin or single ball bearing supported crankshaft and rear disc valve venturi system (à la Eta).

The piston assemblies to be available as a light-alloy two-ringed unit or as a light-weight cast-iron piston for either capacity engine.

Thus from the basic crankcase and head diecastings, two front and two rear diecastings, a combination of eight different builds of engine could be made available to cover all the mentioned requirements.

In conclusion I would venture to say that the 0.35 and 0.29 class of model is easier to handle in the usual British weather conditions than the 0.15 class.

Yours faithfully,

Mansfield,  
Notts.

A. B. SWANSTON.

### Glow for me

DEAR SIR,—I fully agree with your readers Bearne and Halley on the matter of producing a 35 size Miles Special. I

(Continued on page 101)



# Here and There

COMMENTS ON  
CURRENT TOPICS

## RAY GIBBS HONoured by ROYAL AERO CLUB



RAY GIBBS, who has been awarded the Royal Aero Club Bronze Medal for 1956, joins a very select group, this medal having been awarded only eight times since its inception in 1913. The award is, of course, for his achievements in speed flying—no less than two World Records and three British Records. Apart from the recognition of Ray's individual achievements by the Royal Aero Club, the award reflects the increasing stature of the model aircraft movement as a whole and it is, of course, the first time that a R.Ae.C. award has been made to a modeller.

From the list of previous recipients and their citations, it is apparent that outstanding merit is necessary to qualify for the coveted medal. As a matter of interest, the first holder was Harry A. Kauper, who received the Bronze Medal in 1913 for the "Daily Mail" Circuit of Britain Race. Since then it has been made only in 1910(2), 1921(2), 1926, 1950, and when last awarded in 1952, it was to Brigadier General A. C. Lewin, C.B., C.M.G., D.S.O., for his outstanding record of private flying.

Congratulations to Ray Gibbs on his wonderful achievement.

### SUITED FOR THE OCCASION

NO longer will Pylonius be able to make his annual jibes at the shirt sleeves and braces uniform of British teams abroad. The Federation of Model Aeronautical Manufacturers and Wholesalers have offered to provide the S.M.A.E. with eight royal blue track suits for the use of international teams—an offer

which has been gratefully accepted.

Just to make certain that other entrants will recognise our boys out of their traditional uniform, the suits will have a Union Jack and the words Great Britain on the backs.

### SOS

Will Mr. L. Brock, formerly of 1, Rosamund Street, Sydenham, S.E.26, please let us know his new address?

### INDOOR MEETING

GOOD news for the indoor fliers who have been unable to air their models for nearly three years since the last Cardington meeting: the North Western and Midland Areas have combined and arranged a Spring Indoor Meeting at Manchester Corn Exchange and this will take place on Saturday afternoon and all day Sunday, the 13th and 14th April.

The first day is limited to test flying and record attempts, while on the Sunday three contests will be held: F/F over 100 sq. in., F/F under 100 sq. in., and chuck glider. The organisers are, however, prepared to arrange other events if there is sufficient demand, and provided they are notified in advance.

Pre-entry is required and must be sent to the N.W. Area Comp. Sec., J. Chadwick, 129, Mottram Road, Stalybridge, Cheshire, not later than April 7th.

### SPOOKY DO!

the answer to  
this month's puzzle  
pic is on page 95

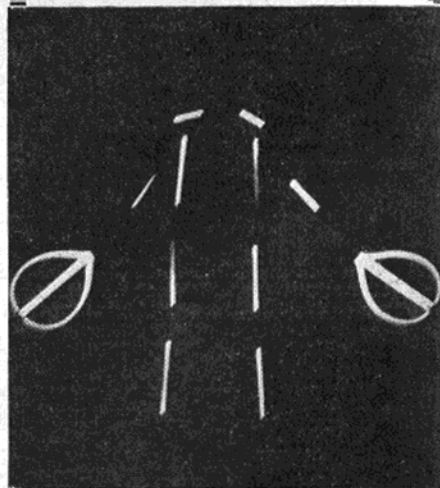

### PROTEST TO F.A.I.

THE recent F.A.I. decisions on the World Championships must not be accepted without demur—that is the unanimous opinion of the S.M.A.E. Council, and it was decided that the first step would be to request the F.A.I. to submit their regrouping decision to postal ballot.

The F.A.I. Director-General's view that delegates should not be instructed by their aero clubs on how to vote, but should have a free hand, also aroused strong feelings. The S.M.A.E. contend that discussion at F.A.I. meetings should be confined to items on the agenda, and that amendments raising totally new issues—the bi-annual change for example—should not be accepted, as they are, in fact, new resolutions.

Certainly no British F.A.I. Delegate will remain in office very long unless the acts and votes as directed by the S.M.A.E. Council.

## PEN PALS

WOULD anyone like to exchange correspondence with a Czech modeller? If so, they should write to Vaclav Smejkal, Petra Bezruce 641, Chabarovice, Czechoslovakia, who, although primarily a speed flier (he was fourth in the recent World Champs), would prefer to write on all types of model aircraft.

Second pen pal request comes from Stanczyk Zbigniew, 10, Kassubka, Wtactawek, Poland, who has been modelling for six years, and is mainly interested in rubber models. He would like to exchange gen with an enthusiast over here.

Also from Poland, comes a request for anyone to exchange English modelling magazines for their Polish counterparts. Anyone interested should get in touch with Zdzistow Hennies, Lublin, ul. Narutowicza 41, Poland.

### QUIZ WINNER

This month's lucky quiz winner is D. Mascarenhas of Cambridge and the answers were 1. (a), 2. (c), 3. (b), 4. (b) 5. (c), 6. (c), 7. (d), 8. (c).

## All in a Week-end's Work!

THE Boeing B-52 *Stratofortress* was designed as a turboprop bomber initially, with a top speed of 500 m.p.h. In the best Hollywood tradition, when the U.S.A.F. asked for something faster, Boeing engineers returned to their hotel, sketched out a new aeroplane with swept wings, eight jets and a 600-plus speed. Next day, which was a Saturday back in October 1948, they went to the local model shop, bought wood, glue and tools and made a scale model of the new design. A local typist was called in on the Sunday to put the engineering data on paper and on

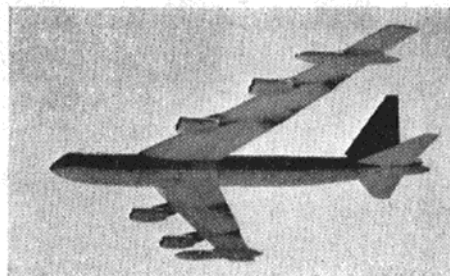

The Boeing B-52.

Monday morning U.S.A.F. officers were confronted with the drawing, model and a 33-page report on what became in due course the B-52.

## A 'Present' Surprise

PRESENTATION to the officers of an area, with thanks and sympathy from a member of the area. Just a pipe-dream you might think—but no, it actually happened at the London Area A.G.M.

Pete Muller was the instigator of the idea, and after the chairman had ascertained that the parcel did not tick, he opened it to disclose a gavel for himself (to beat the more obstreperous members over the head with?), a book of stamps for the secretary, a bottle of aspirins for the comp. sec., a large wooden spoon for the area delegate and finally, for the treasurer, a child's set of counting beads.



## TIGER TALES

RESEARCH need not be as dull as it sounds—that was our impression after collecting the gen for our *Tiger Moth* feature on page 87 of this issue. Apart from the facts and figures side of the job, we heard a variety of yarns that highlighted an amusing incident, or a situation that, although serious at the time, in retrospect provoked a chuckle. With all the hours clocked up by "Tiggie" pilots the world over, there must be a

fund of such stories, and MODEL AIRCRAFT will give a year's free subscription to the best one received, and a six month's sub will go to every other story printed. Keep them as brief as possible—not more than 200 words—and let us have them by February 28th. Only rules are that they must not previously have appeared in print, and they must be fact—not fiction! And don't forget your name and address, please.

## OBITUARY

IT is with great regret that we have to record the death of E. C. (Ted) Muxlow. He was well known, particularly in the north, as a Wakefield and indoor model enthusiast, and in the latter category did, in fact, hold the British Indoor R.T.P. Class A record, from 1948 until November last year, with a time of 6:05.

Ted was for some time a member of the Sheffield Society of Aeromodellers, but more recently flew as a country member. We tender our sincere condolences to his family and friends in their bereavement.





# CLANCY



## AN ALL Balsa FREE FLIGHT BIPLANE FOR

0.5 c.c. ENGINES

by

**M. Ballentyne**

**T**HIS model is quick and easy to build and with a hot 0.5 c.c., V.T.O.'s and tight spiral climbs are easily achieved, although the glide is rather steep owing to the high wing loading. *Clancy* is almost indestructible if the correct grade wood is chosen and if all joints are pre-cemented.

### Wings

A complete sheet of  $\frac{3}{16} \times 3 \times 36$  in. is carved and sanded to the indicated section and then cut into four 9 in. lengths. The two pairs of wings are bevelled at the centre for the dihedral and cemented together, with a cement skin over the joint after it has dried. The tips are rounded and the keying strips cemented in place on the top of the lower wings and on the bottom of the upper wings, to correspond with the edges of the wing seatings. These keying strips are most important and should not be omitted as they ensure the correct alignment of the wings and thus a consistent flight pattern. Finally, the wings are covered with lightweight Modelspan doped on.

Next step is to carve and sand the tailplane and fin, and add keying strips as on wings.

### Fuselage

Cut the fuselage profile from hard  $\frac{1}{4}$  in. sheet and let in the engine bearers, cementing well. Next add

the vertical  $\frac{3}{32}$  in. sheet to the side of the fuselage. When this is dry, drill the holes in the bearers for the engine and undercarriage, and "wangle" the undercarriage through the upper hole. Bind it on with strong thread, cover with linen tape, and give the whole a coating of cement.

The wing mountings are best made on the centre section of the wings themselves and thus the correct angle and camber may easily be obtained. First, smear the centre section of the wing with soap to prevent the mounts sticking to the wing. The upper mount is cut in half, and the two pieces are bevelled and stuck together on the underside of the wing and pinned there until dry. The lower mount is made in a similar manner on top of the lower wing, but has to be curved over the wing as well as dihedralled.

When these mounts are dry, remove from the wings and cement securely to the fuselage, and add the

tailplane mounting. Dope on lightweight Modelspan over the entire fuselage. Add dowels and colour dope if desired.

It is well worth while giving the whole model a liberal coat of fuel proofer as the weight of this proofer will be less than the weight of fuel absorbed after a few hours' flying.

Add the wheels, retaining them by washers soldered on, and bolt in the engine and tank with 8 B.A. bolts with lock nuts. Cut the trim tab, and hinge with Sellotape.

### Flying

It is not necessary to carry out many test glides. Make sure that the rigging angles are correct and that the c.g. is in the right position and try a flight on low power using a 6 in.  $\times$  4 in. Frog nylon prop and slight left thrust. Trim for left turn on power, but on no account use right turn for power; this proved fatal on the original! Do not be afraid of a tight turn to the left as the model shows no tendency to spin unless the turn is excessive. The nose can be kept up with a little right rudder.

Lastly, a word of warning. Do not forget a name and address label; the first *Clancy* was lost on its third flight.

FULL SIZE WORKING DRAWINGS ARE OBTAINABLE FROM YOUR LOCAL DEALER, OR BY POST FROM THE "MODEL AIRCRAFT" PLANS DEPARTMENT, 19-20, NOEL STREET, LONDON, W.1, 3s. 6d., POST FREE

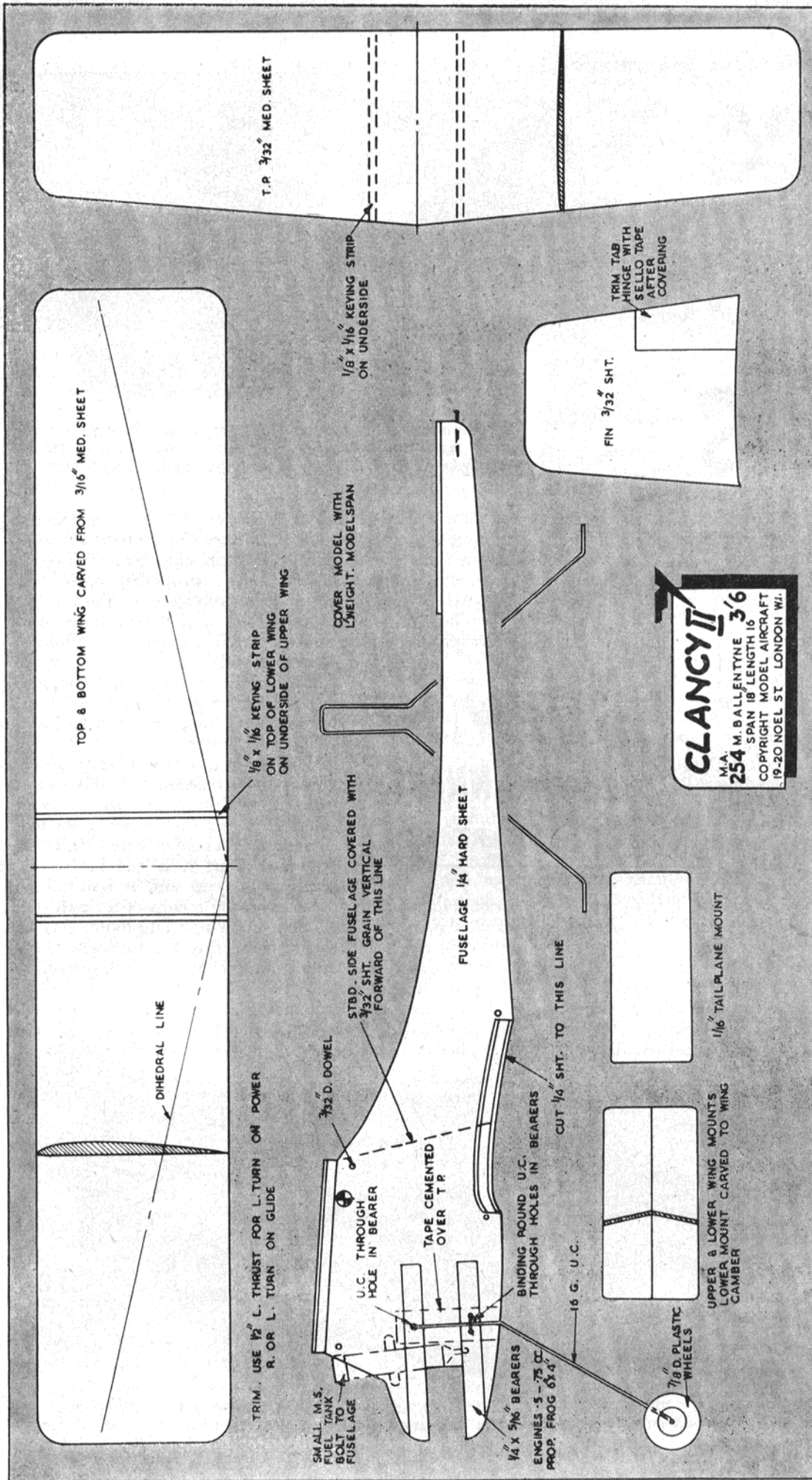

# ★ More Than Two Hundred . . .

plans are listed in the MODEL AIRCRAFT PLANS CATALOGUE—rubber and power driven models, gliders, solids, control line and free flight, etc. Just send 5d. in stamps to "M.A." Sales Dept., 19-20 Noel St., W.1.



# Jetex Motors & Models

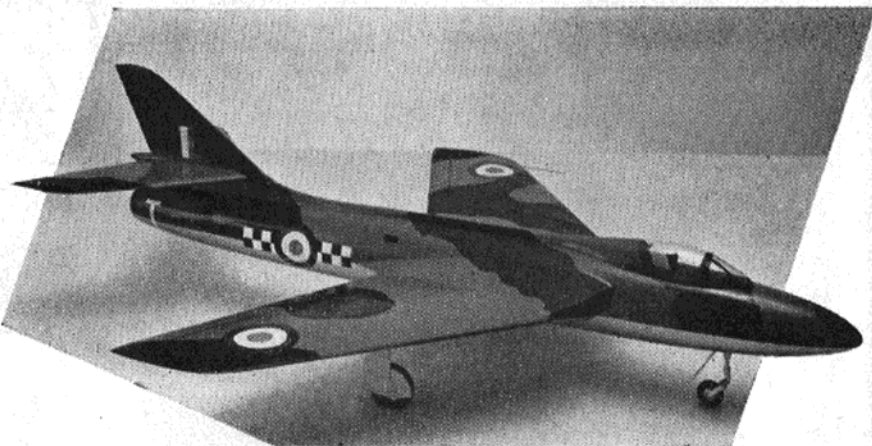

A Jetmaster-powered Hawker "Hunter" built from one of the larger scale Jetex kits. This particular model was built for Sir Sydney Camm, designer of the full-size Hunter jet fighter.

**P**RACTICALLY every type of aircraft has its counterpart in model aeronautics and the jet plane is no exception. Three distinctly different types of jet propulsion have been seen in models up to the present time: the pulse-jet, the ducted fan and the solid-fuel rocket motor.

The first of these, the impulse-duct or pulse-jet, is a true jet engine of a simplified type, running on petrol and operating on exactly the same principle as the power plant used in the German wartime V.1, the so-called "Buzz-bomb." These engines, of which the American Dyna-Jet is the leading example, are mostly between 18 and 24 in. long, are very powerful and very noisy. Their use, mainly for reasons of safety, is generally restricted to C/L models, where speeds in the region of 80 m.p.h. can be reached with 1/12 scale jet fighters and more than double this figure with pure speed models.

The ducted fan system, on the other hand, employs an adaptation of the conventional model piston engine. The engine drives a small diameter, multi-blade propeller or fan entirely enclosed within the fuselage, the high-pressure air stream so produced being emitted through a

suitable tailpipe. Small, lightweight glowplug engines capable of 15,000-20,000 r.p.m. are best suited to models of this type and a commercial application of the system is to be found in the "Imp" propelled Sabre and Lavochkin scale F/F kit models produced by Veron.

By far the most widely used model jet power-unit, however, is the Jetex motor, which is actually a miniature solid-fuel rocket motor. It is easy to operate, light in weight and safe, and is available in various sizes suitable for small and moderately sized lightweight F/F models.

The Jetex motor is a very simple affair and consists, basically, of a cylindrical aluminium case or body into which the fuel pellet is loaded. A length of copper-cored fuse, or igniter-wick as it is called, is then partly coiled up and is maintained in contact with the fuel charge by means of a small disc of wire gauze pressed down upon it. The motor has an end-cap with a jet hole in the centre through which the gases generated by the burning fuel are emitted, providing the propulsive thrust.

Four sizes of Jetex motor are currently produced. These are the "Atom-35," the "50" and "50B," the "Jetmaster" and the "Scorpion." (See Fig. 11.) The

## The NEW M.A. BEGINNERS' COURSE PART XIII

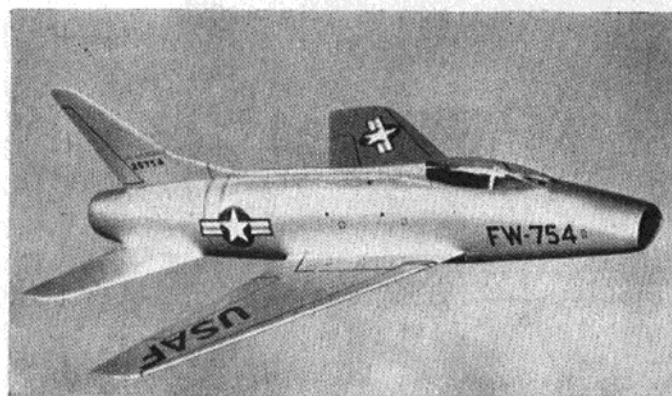

Another Jetex powered scale model, this time of the North American F.100 Super-Sabre and powered by a Jetex 50B motor with augmentor tube which increases thrust up to  $\frac{7}{8}$  oz.



Fig. 1. A typical Jetex scale kit, showing the moulded balsa and resin laminated fuselage shells, together with the aluminium augmentor tube. Kit is the "50" version of the "Hunter."

Atom-35, the smallest of these, is 1.7 in. long and weighs only  $\frac{1}{4}$  oz. loaded and is suitable for tiny models of a foot span or less. The 50 and 50B are slightly larger and weigh approximately  $\frac{3}{8}$  oz. loaded, the 50B being intended for use with the special augmentor tube supplied with this model. The Jetmaster weighs one ounce and can also be used with an augmentor tube, which increases its nominal thrust from  $1\frac{3}{4}$  oz. to  $2\frac{1}{4}$  oz. The largest model, the Scorpion, delivers a thrust of 5.5 oz. for a weight of 2 oz. and can also be used with an augmentor tube.

Augmentor tubes are in the form of a large-diameter tailpipe of thin gauge aluminium, into which the gases from the jet are discharged. The tube is bell-mouthed at the entry so that the Jetex unit positioned there does not restrict the passage of air from the front. The addition of the tube not only helps performance, but also makes the whole installation ideally suited to scale models, in which the motor must be enclosed within the fuselage.

Kits for Jetex models, both duration types and scale designs, are available and the manufacturers of Jetex motors also make a number of excellent kits of modern jet aircraft. These Jetex kits, which are of unique design and excellent quality, have so far been produced in two size groups, the larger for the Jetmaster motor with augmentor tube and the smaller for the 50B with augmentor tube.

For our construction sequence we have chosen one of the latest of these kits, the Jetex 50B powered version of the Hawker Hunter fighter. This little model is of all-balsa construction with hollow, sheet balsa wings. There is also a larger version of it (20 in. span and 25 in. long) for the Jetmaster, with built-up, tissue-covered flying surfaces.

The most interesting feature of these Jetex kits is the fuselage structure. Models of modern jet aircraft, with their streamlined, rounded-section fuselages, usually call for a somewhat complicated internal structure of formers and longitudinal members and, in order to preserve an accurate representation of the plating and true rounded shape of the prototype, balsa planking, rather than stringers and tissue covering, is to be preferred. Unfortunately, planking is a rather tedious operation and usually means more weight than is desirable with a small F/F model, and the Jetex system of pre-moulded sheet balsa shells is an ingenious solution to the problem. The shells are made of two plies of thin sheet balsa wood with a sheet of special thermo-setting resin film between

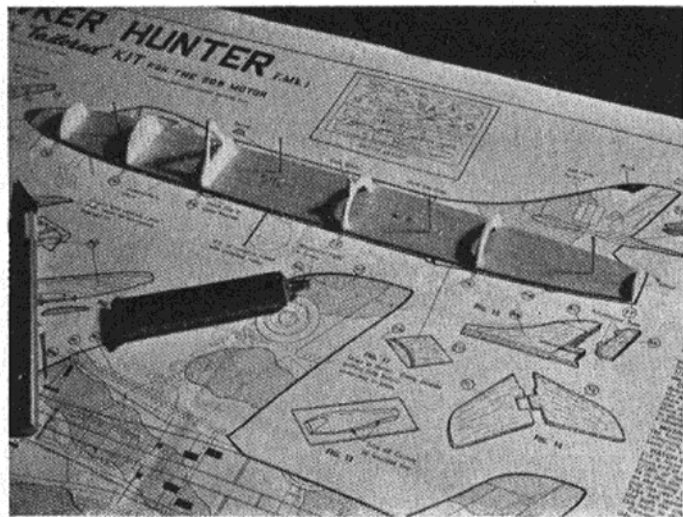

Fig. 2. Balsa keels or backbone members are attached to the plan and half-formers cemented in position as shown.

them. Heated and pressed between suitably shaped dies, the plies emerge as perfectly contoured half-shells. In this form they are supplied in the kit, requiring only a simple internal structure. Accuracy of assembly is assured by the use of special jigs also supplied in the kit.

All sheet balsa parts in the kit are ready diecut. Unlike that found in some kits, the diecutting is exceptionally clean and accurate, but parts are not marked and before detaching them from the sheets, it is advisable to number them in accordance with the layout shown on the kit plan.

The construction is started by attaching the plan to your building board in the usual way, then pinning each fuselage keel in position and cementing the formers to it as shown in Fig. 2. Note that the keel centres are left intact at this stage.

The next step is to make up the cardboard fuselage jigs. (Fig. 3.) Parts for these are diecut but require the use of a modelling knife or steel backed razor-blade to separate them cleanly. The fuselage shells are then trimmed to length and the wing root openings and wing root slots are cut in them. Outlines for these are clearly marked by indentations on the outer surfaces of the shells and these indentations can be relied upon as being accurate and correctly located.

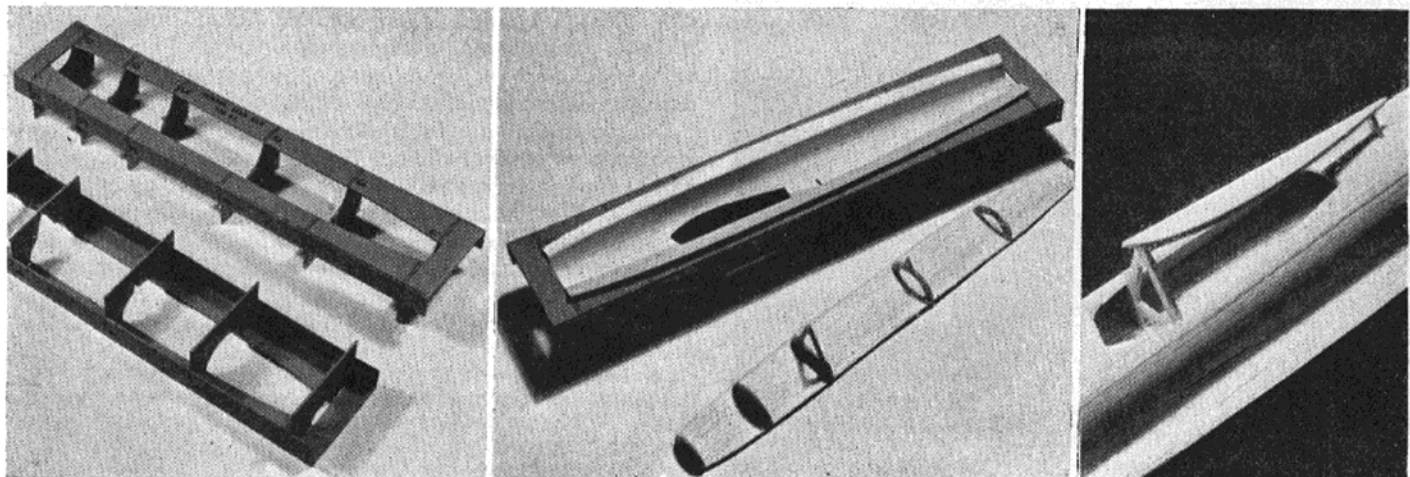
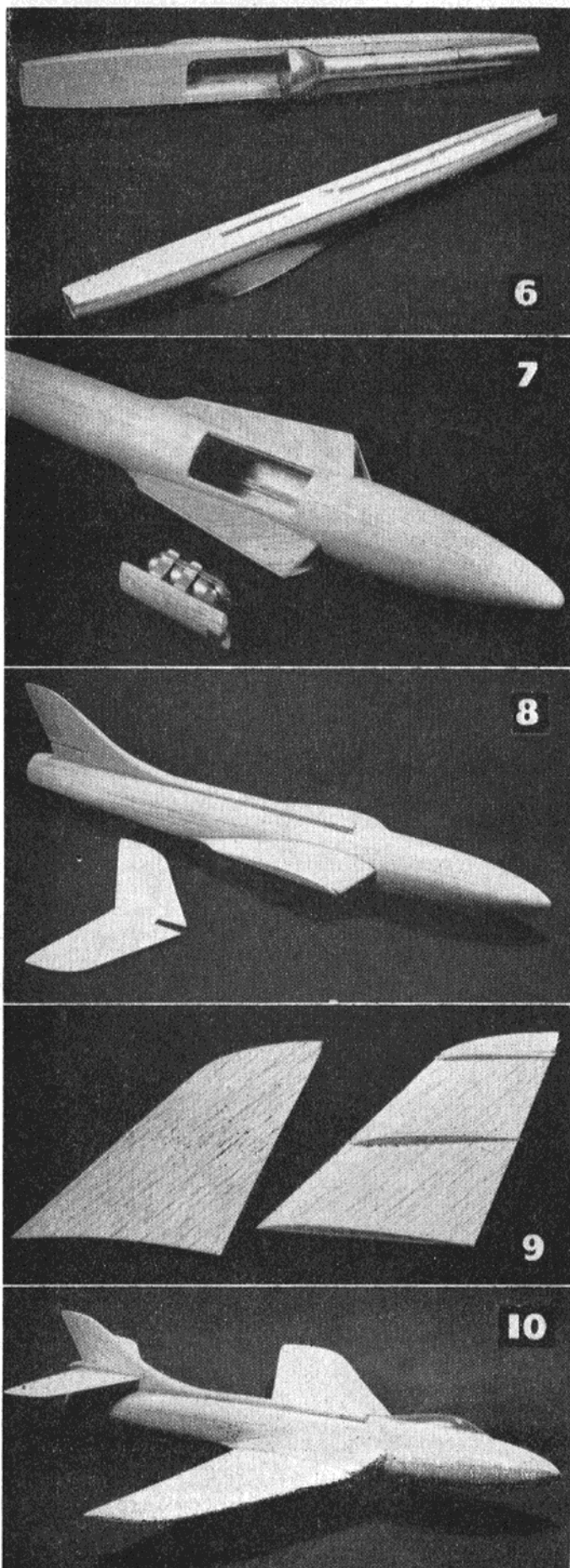

Fig. 3 (left). Showing the cardboard jigs, in which the fuselage sides are assembled. Fig. 4 (centre). Fuselage shells are laid in their respective jigs, and keels, with half-formers, are cemented to them. Fig. 5 (right). After removal of the fuselage sides from the jig, wing root ribs are positioned as shown and fairings added.





With the shells placed in their respective jigs (Fig. 4), the keels are removed from the plan and, after applying cement to their edges and to the formers, are fitted into the shells. Make sure that they are pressed well home. If necessary, lift the shell from the jig temporarily to check this. Leave plenty of time to dry.

The first step after removal of the fuselage halves from the jig is to cement the root ribs in position (Fig. 5), followed by the  $1/32$  in. sheet balsa fairing panels. When these are set, trim the excess flange from the fuselage shells (we found an X-acto miniature plane handy here) and rub down carefully with sandpaper until level with the keel surface.

The keel centres are now removed and the augments tube fitted in position. (Fig. 6.) Check the fit of the two fuselage halves, then cement them together, wrapping with strip rubber until set.

A rectangular block of balsa is supplied for the nose-block. This has a recess at the back into which the two noseweight discs provided should be fitted. To make sure that these are held securely in position, cut a piece of scrap balsa and cement in the recess after the noseweights. Then, after liberally pre-cementing, fix the noseblock in position. Carve and sand to shape when dry and sand the fuselage to a smooth finish all over.

The motor hatch aperture is now cut out as marked on the bottom of the fuselage and the reinforcing strips fitted. The pre-shaped hatch block is bevelled to fit snugly in the aperture and is held in place with the special Jetex hatch catches supplied. If necessary, lightly sand the bottom surface of the fixed part of the clip (before assembly) so that it will slide easily. Double pre-cement the hatch cover slot before fitting the catch, then fit the latter with a minimum of cement so that it does not get between the sliding surfaces. Finally, cement the motor clip to the hatch cover, checking the alignment of the motor by sighting down the augments tube. (Fig. 7.)

The rest of the construction needs little explanation. The tail fin is made from four laminations of  $1/16$  in. balsa and then sanded to shape. Make sure that it is truly vertical when cementing in place. The rudder is attached with tabs of thin aluminium (supplied) and the tailplane is slotted into the trailing edge of the fin. (Fig. 8.) The wings consist of a flat undersurface of  $1/32$  in. sheet balsa to which ribs are cemented, the curved upper surface then being added. (Fig. 9.) The wings should be built up over the plan, the upper surface being pinned down around the edge while the cement dries. The complete wing panels are butt jointed to the centre-section. Make sure that they are aligned with the fuselage (Fig. 10.)

The complete model should be sanded all over and given a coat of clear dope. A model of the *Hunter's* small size and relatively high wing loading cannot be expected to perform like a duration model: its flight is necessarily fast and brief, but if you require the best possible performance, avoid adding too much weight with too many coats of dope. As a compromise, a coat of sanding sealer, well rubbed down, followed by two thin coats of

Fig. 6. After trimming shell flanges, keel centres are removed and augments tube fitted, then the sides may be cemented together.

Fig. 7. With noseblock cemented in place and shaped, the motor access aperture is cut out and the hatch and motor clip fitted.

Fig. 8. To the completed fuselage, the fin and rudder are now added, followed by the tailplane.

Fig. 9. The simple wing structure consisting of  $1/32$  in. sheet covering over  $1/16$  in. ribs.

Fig. 10. The complete "Hunter" structure, ready for finishing.

dope, is suggested. The model may be doped all-aluminium colour, or grey and green camouflage on the upper surfaces. A complete set of transfers is included with each kit and other details can be marked with dope or indian ink.

As regards actual flying, the model should be test-glided in the usual way after checking the balance in accordance with the instructions. The rudder is intended as a means of correcting any tendency to turn off course and it will be found safest to adjust for a straight power flight or shallow turn and not to attempt a circling flight.

A word now about Jetex motors and their operation and maintenance.

Fig. 12 shows a Jetex Scorpion dismantled. The smaller motors contain the same essentials but are of simpler design. All Jetex motors embody an end-cap secured with spring-clips. The purpose of the spring clips is not merely to hold the end caps in place but to act as a safety valve. The gas generated by the burning charge accumulates in the free space behind the end cap and acquires considerable pressure. Release of this pressure normally takes place, of course, through the jet, but should the jet become blocked while the charge is burning, the resultant build up of pressure would tend to burst the casing unless some kind of relief valve were provided and this is achieved by the spring clips, which allow the cap to lift if the pressure becomes excessive.

A jet may become blocked or restricted by carbon or a fragment of gauze or igniter wick. To guard against this a number of rules should be observed. Firstly, the jet should be re-sized after every flight by means of the short wire rod or reamer supplied for this purpose. (Fig. 13.) Secondly, the gauze which presses the coiled end of the igniter wick onto the fuel pellet should be in good condition and not burnt through. Normally a gauze will last for about five firings, after which a new one should be used. Thirdly, the revised method of installing the igniter wick (as now recommended by the makers), in which a short, separate length of wick is inserted through the jet, should be used.

All Jetex motors get quite hot as the charge is burned and need to be allowed to cool for a few moments before handling. This heat may also cause the end-cap washer to stick to the case, and so as not to damage the gas seal, it is recommended that the body and end-cap are not merely pulled apart abruptly after releasing the spring-clip. Instead, the two parts should be pressed together and rotated as in Fig. 15.

Finally, remember that cleanliness is of the utmost importance with all Jetex motors. After each flight, the deposit which accumulates inside the case should be scraped out with the wooden scraper supplied. (Fig. 14.) The motor should also, occasionally, be thoroughly cleaned by dismantling and scrubbing in hot soapy water. The makers recommend that this be done after every twenty firings, or whenever you are not expecting to use the motor for a while, so as to avoid the risk of corrosion.

Fig. 11. The Jetex range of motors includes (left to right): the Scorpion, the Jetmaster, the 50, the 50B and the Atom-35.

Fig. 12. The Scorpion motor completely dismantled. The Scorpion is the most powerful Jetex motor to date.

Fig. 13. After firing, the jet must be cleared with the wire rod.

Fig. 14. Carbon deposit in the case, left by the combustion of the fuel, must be scraped out before recharging.

Fig. 15. When removing the end-cap from the case after use, the two components should be rotated against each other to prevent damage to the sealing washer.

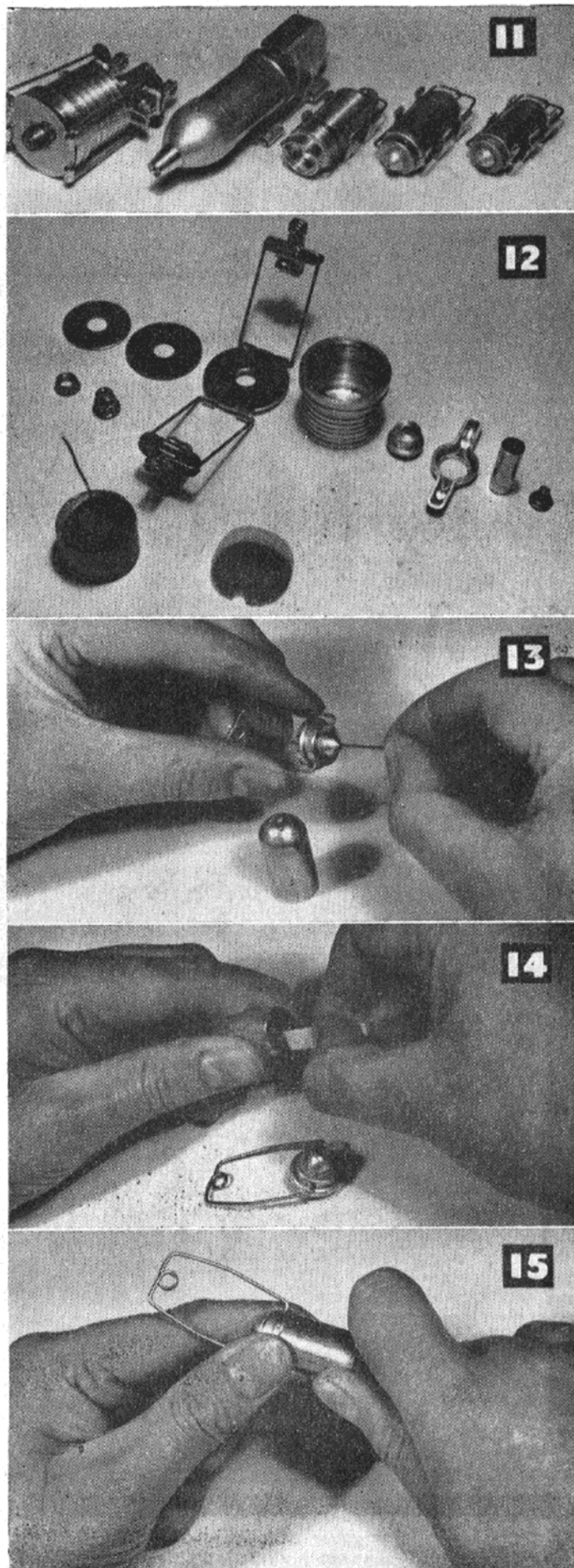



# Topical Twists

by PYLONIUS

## Simply Overpowering

Now, I'm no great shakes as an engine expert, except when a 5 c.c. effort whizzes past my ear, then there's no greater shaker in the business. What I mean is that when I discourse on the ironmongery side of the business I have to tread cautiously—no use leading with my Chinn out.

Well, it seems to my untutored eye that a 1 c.c. engine packs more than enough concentrated wallop to keep any prop-flicking hobbyist in raptures of delight. Neither is it lacking in the other shining virtues.



The noise output is sufficient to keep those anti-social types who have the impudence to live on the fringes of our airfields in a state of apoplectic fury. Oil discharge is well up to expected standards; model and modeller being reduced to a soggy reeking mass in a matter of minutes. And,

as far as starting capabilities are concerned, they can, if treated rightly, take every bit as long as their bigger finger chewing brethren. I know a few innocent manufacturers produce some one-flick wonder units, and the unsuspecting hobbyist might easily find himself palmed off with one of these. But, happily, there are ways and means of rendering them reasonably futile. A 4 in. x 4 in. prop, the home made tank and a drop or two of the club wizard's super brew are all well tried and successful remedies for the start-happy engine.

Zip, noise, mess and hours of joyful flicking. What more could you ask? Well, a jolly sight more if recent "Letters to the Editor" are anything to go by. The general clamour is for the monster variety of balsa shatterer, or, should I say, bench vibrator. But I am unjust in hinting that such engines lead a completely bench bound existence, for one correspondent tells us that he intends fitting his pet monster in a scale steamroller—possibly a half size effort.

Don't get the idea that monster engines are any new thing. Back in the days when every modeller was a colonel and every model a steamroller (or, that's what they looked like), 30-50 c.c. efforts were all the rage. However, the masses of ironmongery concealed only a fraction of the power of a modern 10 c.c. unit, and we can take this as the reason why the colonels survived until quite recently. We hear of them no longer, and we can only assume that they were tempted to put the new monster units in model planes. What horrible fate befell them on their lonely grouse moors we shall never know.

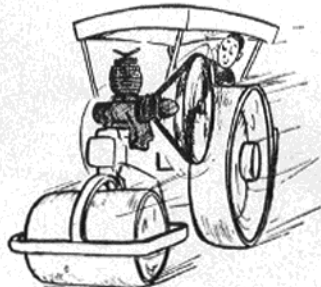

Undisputably, the model engine is a fascinating toy—a thing of beauty to the boy forever. Even veteran modellers get an uncontrollable itch in the old prop finger at the mere sight of a provocative little diesel, though judging by the chopped-up state of that much abused digit, they are old and

wise enough to know better. As for the yet undamaged beginner, it inspires him with mechanical inspiration—how to get his piggy bank open for the first down instalment. Sometimes he is so carried away by the wonder of his new finny friend that he goes out and buys a dinky little kit to keep it company. It may also happen that he is one of those rare creatures who will actually build it. Of what occurs after that I have no personal knowledge. I can only refer you to the glowing testimonials in the adverts.

Apparently, the pet engine and kit are taken to the nearest airfield, the tank filled up, and the model launched into the clouds on its first and last glorious flight. The stopwatch clicks off at about 2 hr. 30 min., and the model-less beginner trots happily homeward, aglow with pride and achievement.

Now, what he does next is a matter for speculation. Does he first sit down to write that glorious tribute to the kit manufacturer, or does he get cracking on the piggy bank?

\* \* \*

## A Cutting Reply

I see that this enterprising magazine is offering a set of balsa knives to the sender of the funniest and most controversial letter. Well, I, in my own humble way, have been bashing away at this funny and controversial stuff from the days when balsa knives had flint heads, but, so far, all I've been offered by way of reward is the business end of a building board and an extra-hard block of balsa. No one has yet come across with a set of balsa knives. But just you wait until they see my competition entry—all about the history of my vintage razor blade, and what a splendid model knife it makes after all these years.

\* \* \*

## Top of the Pops

In these model glutton days even the poetically minded bloke has a job to find a name for his latest three-evening effort. After that first proving flight inspiration might not be so lacking, though the apt title might not meet with the approval of the local Watch Committee. If, on the other hand, the model looks like surviving into the next club report (well, a year's not long if you look after it carefully) a spot of moniker meditation is the order of the day.

Anyway, one bright spark seems to have got over the brain racking problem by naming his model after popular songs. This method, though, relies too much on topical flavour to be of much use with the average P.R.O. The time your "Rocking Thro' The Rye" gets into print it's as out of date as "Nellie Dean."

Still, the idea has possibilities, particularly for the pop fiend who happens to be the club P.R.O. If some characters can squeeze cameras into their models there should be room for one of those small L.P. discs. This should make the Sunday flying session more sociable. You wouldn't have half the club dashing off early to listen to "Family Favourites."

\* \* \*

## A Shock for Modellers

I haven't been to Chobham for quite some time. Perhaps I now feel that life is to be enjoyed. Even so, I was surprised to learn that its natural, unspoiled charm has been added to by a cradle of high tension wires.

Usually this form of rural decor is reserved for famous beauty spots, and we can take its appearance on the Chobham desert to be a sort of backhanded compliment. If the electricity people place higher value on spoiling our fun than ruining some glorious stretch of countryside, aeromodelling can indeed feel itself exceptionally honoured.

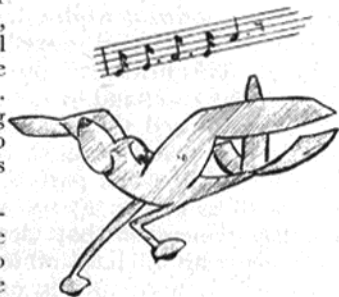

THE relay is the heart of a R/C receiver—an electro-mechanical device converting a current change in a receiver valve circuit (produced by the receiver responding to a signal from the transmitter) into mechanical switching (via movement of the relay armature “breaking” one and “making” another contact). For the purpose of connection, therefore, the relay provides two distinct circuits—Fig. 1. The relay coil (or coils) terminating at “A” and “B” is connected in with the receiver circuit. The armature (3) and the two contacts (1 and 2) are connected in the external or actuator circuit. Contact (1) in this diagram is assumed to be the contact against which the armature rests when no (or very low) current is flowing through the relay coil. Commonly this is left unconnected. Thus the armature and contact (2) acts as a simple “off-on” switch, being “on” (completing the actuator circuit) when full current is flowing through the relay. Alternatively contact (1) may be used as the “on” contact and (2) disregarded. The actuator circuit is then switched “on” whilst there is no (or low) current flowing through the relay coil, and “off” with maximum relay current.

Relay requirements for a simple, lightweight receiver are exacting. The

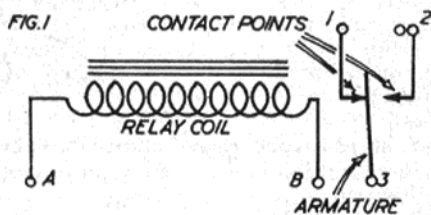

coil is connected in the anode circuit of the valve and thus to the high tension battery supply. Maximum current flow is, however, inherently low (as low as 1.5 to 2.0 milliamps in some cases). Thus the relay must be made extremely sensitive for the armature to pull in at a low current and drop out again at some slightly smaller current. The excess of top current over the “pull in” current largely determines how well the relay will hold in under vibration, etc., although, of course, this is also influenced by relay design.

Sensitive relays invariably have a large number of turns and consequently a high coil resistance in order to achieve the required degree of electro-magnetic “force” on the armature, consistent with sensitive adjustment. The armature itself is usually of the pivoted type (both unbalanced and balanced weight, about the pivot point) or in the form of a reed or cantilever spring, fixed at the end

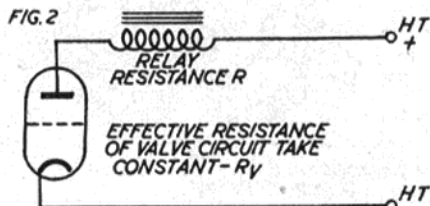

## Radio Control Notes on

# RELAYS

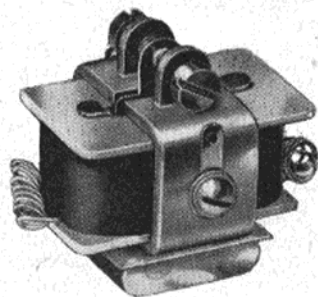
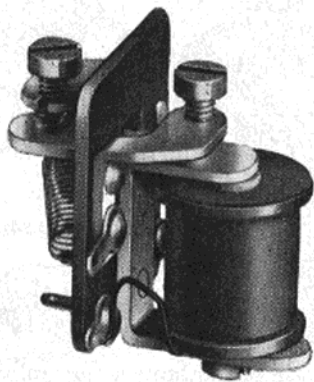

farthest from the coil pole piece(s). A pivoted armature needs a light spring attached so that it is normally pulled away from the pole piece(s). The actual movement of the armature is limited by adjusting the two contact points (usually silver-tipped screws) to suit.

The “pull in” current may be adjusted both by altering the spring tension on the armature and the outer (2) contact screw (in a majority of relays the spring tension is fixed, hence all adjustment is made by altering the contact position). The “drop out” current is governed by the size of the air gap left when the armature is pulled in. The armature must never be allowed to touch the pole piece(s) as otherwise it will tend to stick and be reluctant to drop out at all even though there is no current flowing through the relay coil. Thus, an air gap of 2 to 3 thous. is usually allowed to prevent this happening. Finally, the sensitivity of the relay adjustment, i.e. the difference between the “pull in” and “drop out” currents is dependent on the air gap between the contact points, although this is also dependent on the gap between the armature and the pole piece(s).

The effect on standing or “high” current, of using relays with different coil resistances and the effect of different high tension voltages can easily be calculated. The relay circuit is equivalent to that shown in Fig. 2 where the valve, in passing current, acts effectively as constant resistance  $R_v$  in series with the relay coil resistance ( $R$ ). Therefore the total resistance of the circuit is  $R + R_v$ .

Thus if on a particular receiver the standing current is 3 milliamps with an 10,000 ohm relay and 60 volts high tension :—

$$\begin{aligned} \text{By Ohm's law—total resistance (ohms)} \\ &= \frac{\text{volts}}{\text{amps}} \\ &= \frac{60}{.003} \\ &= 20,000 \end{aligned}$$

Thus the effective resistance of the valve in this circuit is 20,000—10,000 (the relay resistance) = 10,000 ohms.

Now with a 5,000 ohm relay the total resistance would be 10,000 + 5,000 = 15,000 ohms. Thus with the same 60

volts high tension :—

$$\begin{aligned} \text{current (amps)} &= \frac{\text{volts}}{\text{resistance}} \\ &= \frac{60}{15,000} \\ &= 4 \text{ milliamps} \end{aligned}$$

If both relays had similar current sensitivity and could be adjusted to the same “pull in” point, the lower resistance relay would have an additional safety factor of 1 milliamp current to hold it in.

Similarly with an increase in high tension voltage. Taking the first example again with 90 volts h/t instead of 60 :—

$$\begin{aligned} \text{current} &= \frac{90}{20,000} \\ &= 4.5 \text{ milliamps} \end{aligned}$$

Or with a 5,000 ohm relay

$$\begin{aligned} \text{current} &= \frac{90}{15,000} \\ &= 6 \text{ milliamps} \end{aligned}$$

### Manning Carr

This is a polarised relay, i.e. has a permanent magnet or polarised field so that the coil attraction either opposes or assists the existing magnetic field. Polarised relays, as a consequence, have increased sensitivity. Another feature—not used on simple radio circuits—is that they can differentiate between the

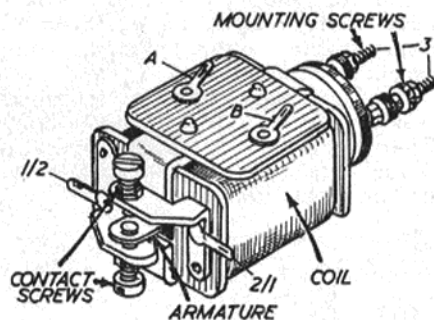

polarity of current applied. The “make” and “break” contacts (1 and 2) are, of course, determined by the polarity of the electro-magnet (coil) or the way in which the coil connections (A and B) are connected.

The Manning Carr relay has good contact pressure and a stable operating



point, although prone to vibration effects unless the standing current is substantially above the pull-in current. The latter is, of course, fully adjustable, but the makers recommend operating at 25 milliwatts, corresponding to 1.9 milliamps.

**Data**  
Coil resistance (standard) 7,000 ohms ; weight 1 oz. ; contacts : screw type with lock nuts.

**E.C.C. P.-100**

Although no longer in production, many thousands of these relays are in use. This is another polarised relay, enclosed with a moulded plastic case. The relay plugs into a six-position socket. Polarity (of the coil connections) can be reversed by withdrawing the relay from the socket, turning through 180 degrees and replacing.

Adjustment of the P.100 is quite

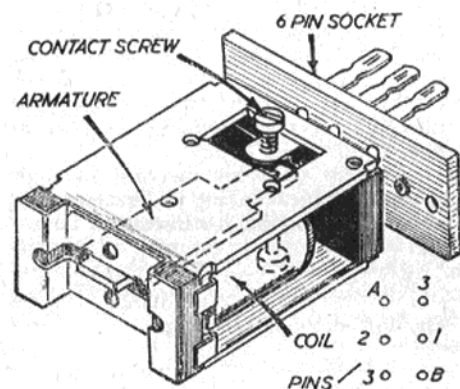

tricky, although satisfactory operation can be achieved on a pull-in current as low as 0.5 milliamps. However, this relay is quite sensitive to vibration and also shows a tendency for the setting to wander—sometimes by as much as 0.5 milliamps. A production jiggling fault was presumably responsible for the fact that the contact screws did not line up with the armature contacts.

**Data**  
Coil resistance 3,500 ohms ; weight (bare) 1 oz., (cased) 1 1/8 oz. ; control setting (pull in) 1.8 to 2.2 m/a ; armature suspension : torsion strip.

It is understood that an improved version of the P.100 is to be produced by Electronic Developments, this company having purchased the tools, etc., from the late E.C.C. concern.

**Siemens High-speed**

This is not a standard model relay but has been widely used by modellers on account of its excellent characteristics. In its original form it is mounted on a heavy metal base. A necessary modification is to remove the relay components and re-mount on a lightweight baseplate (e.g. paxolin), usually the chassis of the receiver.

The armature is of the reed type with

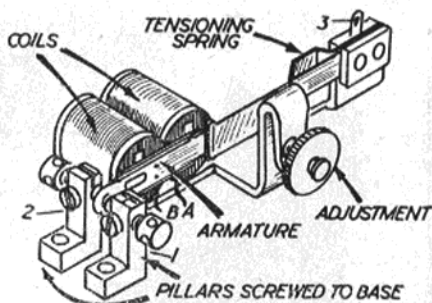

a tensioning or "pressure" spring bearing against it, adjustment of this spring being by means of a large knurled knob.

For ease of adjustment, an operating current of 3 m/a is desirable. It is best to adjust for a very small gap when a differential of 0.2 m/a in 2 m/a can readily be achieved.

This relay is extremely good in resisting vibration and is also capable of following 50/50 mark-space ratio signals (square wave form) up to several hundred cycles per second.

**Data**  
Coil resistance 3,400 ohms ; weight (bare parts) 1 1/2 oz. ; contact points : platinum ; min. operating power 7.5 milliwatts ; recommended operating power 30 milliwatts.

**Ripmax A.20, A.30 and A.40**

These relays are of the conventional type, with single coil and unbalanced armature, aimed at achieving adequate performance at a low price. The fact that the armature is unbalanced makes it susceptible to attitude, i.e. the "pull in" and "drop out" points will change depending on the attitude assumed by

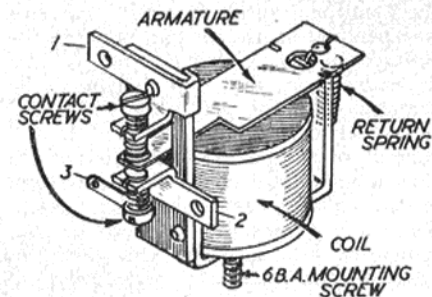

the relay after initial adjustment. However, adjustment is easy and a differential as low as 0.15 milliamps at 2 m/a can be achieved. Contact pressure is good and shock resistance of the order of 7g per m/a above "pull in" current with 0.004 in. gap over pole piece and a similar gap between contacts. Recommended setting for "pull in" is around 2 milliamps.

Contact screws are silver tipped and the remaining metal parts of the relay are bright plated. Mounting is by a single 6 B.A. screw. A number of different types are produced—A30, coil resistance 5,000 ohms (standard for receivers) ; A30H, 10,000 ohm coil, but otherwise identical ; A20, 5,000 ohm coil ; a miniaturised version, but with

similar performance ; A40 slave relay, low resistance (15 ohm) coil with increased contact pressure (stronger armature return spring) and fixed contact setting (silver rivets replacing the screws). Intended for operating on 1.5 volts and rated to carry 4 amps D.C. at 12 volts through the contacts

weight : A30—1/4 oz.  
A20 (miniature)—1/2 oz.

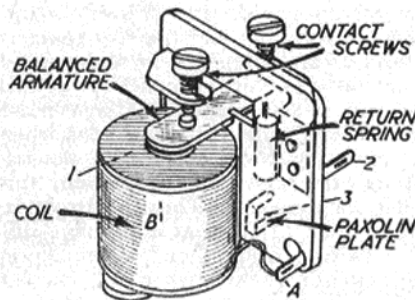

**E-D Standard**

A lightweight, single coil relay with a mass-balanced armature, pivoted at its mid-point about a knife edge formed by the yoke. Stout brackets are riveted to the paxolin backplate to carry the contact screws, these being silver tipped. Contact pressure is light and with the relatively thick armature, the relay is susceptible to vibration. Also there is a tendency for the settings to wander, although the relay is not affected by attitude.

**Data**  
Coil resistance 5,500 ohms ; weight 9/16 oz. ; minimum operating power 5.5 milliwatts.

Max. safe D.C. coil current recommended by the manufacturers is 3 m/a, although this can safely be increased to 6 m/a.

**E-D Polarised**

Armature suspension is by means of a phosphor-bronze torsion strip. Again the operating points appear to be a little unstable, although not greatly affected by attitude. This relay is also rather temperature sensitive. The polarising (permanent) magnets are of rod top, accommodated in a dural base plate.

**Data**  
Coil resistance 4,000 ohms ; weight 1 oz. ; minimum operating power 2.5 milliwatts ; max. safe D.C. coil current 10-12 milliamps.

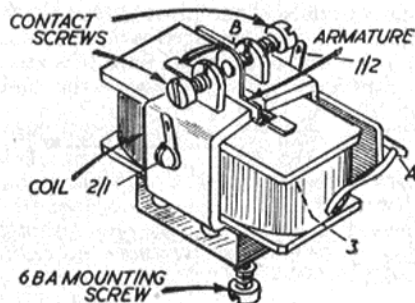

# ENGINES ONLY

by **PETER CHINN**

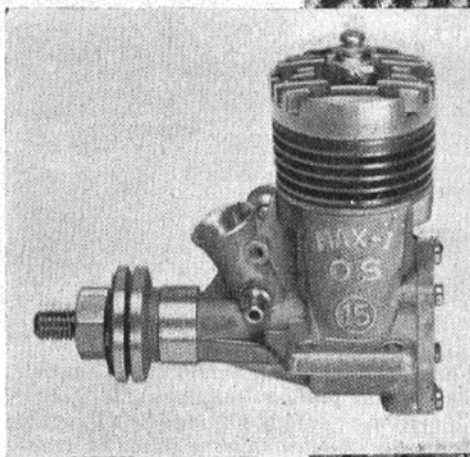

**T**HIS year, space, or, rather, the lack of it, prevents us from including our impressions of all the interesting engines, models, R/C gear and accessories that have passed through our hands during the past twelve months. Therefore my notes are confined to engines only.

A word first about the high-performance engine of the year. Coming at a time when manufacturers' interest in model racing engines of all types (except, perhaps the 2.5 c.c. class) seems to have sunk to its lowest ebb, the advent of the American Fox 29R and our subsequent receipt from manufacturer Duke Fox of one of the current production models, was indeed refreshing.

The Fox is purely a racing engine and while, no doubt, some people will succeed in adapting it to other applications, no concessions are made in its design to give it any appeal outside the speed circle. The 29R, however, owes little to the classic racing layout as exemplified by the Dooling and McCoy. At the same time, it is definitely not merely an adaptation of a standard 29 layout and one should not be deceived into supposing that the suffix "R" merely indicates a "hopped-up" version of the well-known Fox 29 model. The 29R is an entirely new engine from the casting up and nothing quite like it has been seen before.

Handling the 29R, one's immediate impression is of size. It has the bulk of a 0.49, nearly as much weight (8.8 oz.) and a vast air intake that is bigger than that of any stock 10 c.c. racing engine. Obviously, such an intake area, with its negligible fuel suction, requires some revised

thinking as to how the fuel is to be persuaded to reach it and the obvious answer is pressurisation. On the Fox this is achieved by means of a bladder tank or some such similar system and the rate of flow is regulated by means of a special needle valve mounted on the rear cover plate.

A large intake can be of little use if the communicating gas passages to the crankcase are not of similar dimensions. Since shaft induction is used by the 29R, this has called for a crankshaft journal of a full half-inch diameter. The shaft, which is fully counterbalanced, is carried in a single inner precision ball journal bearing, supplemented by a plain outer bearing.

The theme of the Fox 29R is maximum volumetric efficiency—physically and chemically. It starts off, as we have seen, with vast intake passages, and having reached what must be close to the limit to the

amount of oxygen that can be persuaded into a 5 c.c. engine from the atmosphere, Fox has concentrated on supplementing this with the maximum amount of oxygen-producing fuel additive—nitromethane.

The Fox 29R was designed to operate on 50-70 per cent. nitromethane and the rest of its design is apparently aimed at dealing with the maintenance of adequate heat dissipation and freedom from distortion. Originally the 29R was fitted with twin glowplugs and a plain unfinned head, but it was found that the combination of this with high nitromethane fuels and warm weather caused overheating, and a new, deeply finned head, with single plug, is now fitted as standard.

The Fox 29R is not a cheap engine: it costs \$27.95 (approximately £10), but it must be remembered that developing a new racing engine is a slow and expensive

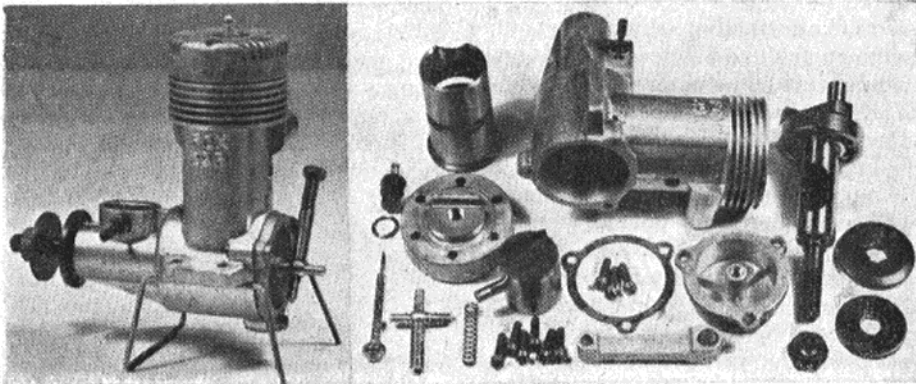

One of the outstanding newcomers of 1956 was the new Fox 29R racing model in which bulk has been largely ignored in the interests of achieving the highest performance in the 5 c.c. class. In 1956, a Japanese engine, the O.S. Max-15, in a British model, won the World F/F Championship. Our heading photo gives pictorial evidence of expanding production: new Max 15's ready for packing.



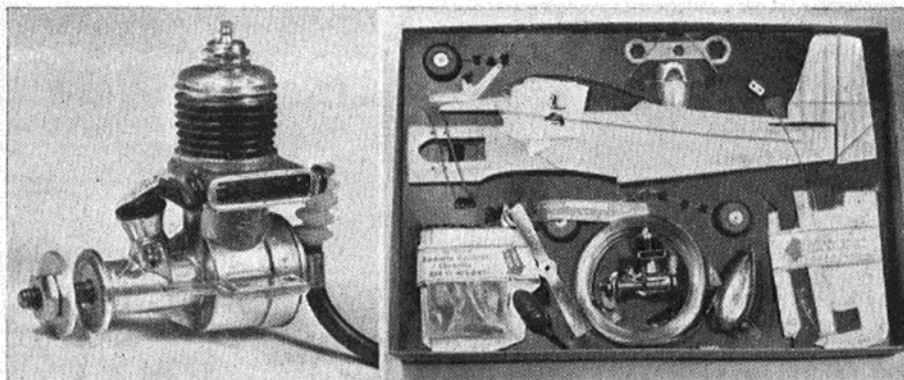

Jim Walker pioneered the U-control model and his inventions have been much in evidence ever since. One of them is this pneumatically operated throttle control on the Walker Firecracker engine. The unique "Firebee" kit (right) contains not only this engine, airline and pressure bulb, but all other items required to complete the model including tank, prop, control-lines and handle.

business. The 29R as supplied in stock condition is undoubtedly a potential winner, but the enthusiastic speed model builder is not expected to stop there. The Fox company freely state that they believe a good deal of development work can still be carried out on this design and they also give a list of the possible small

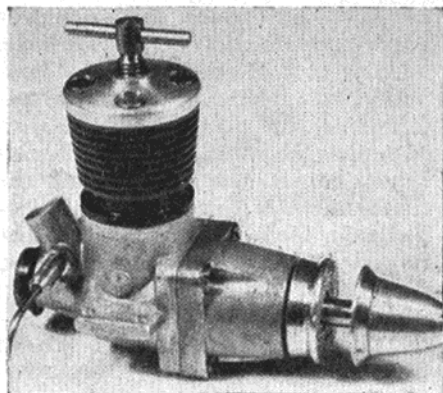

Latest addition to the Super-Tigre line is the G.31 diesel.

modifications that the expert may care to try. An offer of \$100.00 is made, incidentally, for any modified 29R that exceeds the performance of the factory's own specials.

From Italy, during 1956, came two out-of-the-rut designs from the two manufacturers currently active. The first was the Barbini B.40 TN glowplug 2.5, recently featured in the "Engine Tests" reports and which, with modifications, put up such a good show in the World Speed Championships. Towards the end of the year, the piston was slightly altered and having just received one of the latest versions, we are hoping to run some further tests on it in the near future, and to publish some

photographs showing the unique roller and needle bearings of this finely made engine.

The second Italian was the new Super-Tigre G.31. This is a 1.5 which belongs to the new generation of really high-speed diesels—it peaks at about 16,000—and it is a very interesting design on account of its rear shaft induction system with twin ball bearing crankshaft. Like all Super-Tigres it is beautifully made.

Similar in performance characteristics to the G.31 was Graupner's new Taifun Hurrikan reed-valve twin b.b. 1.5 featured in the September Engine Test. Another pleasing little German design was the Star 0.5 c.c. diesel and, from the Webra factory in Berlin came their three new glowplug models: the 1.7 c.c. Sport-Glo, the 2.45 c.c. Mach-1 Glo (of which more anon) and the 0.78 c.c. Piccolo-Glo—incidentally a much more well behaved engine than the original diesel Piccolo.

From Japan, the year was marked by four new models from the Enya company of Tokyo. Though perhaps

less well-known to British modellers than the other leading Jap make, the O.S., Enya engines impress as being soundly designed and very well made. The Enya 15 glowplug model has already been briefly described in MODEL AIRCRAFT and will shortly be featured in the test series. The 15D diesel was, of course, described last month and is Nippon's first venture into the 2.5 c.c. competition diesel class. The 3.2 c.c. Enya 19 appeared in an entirely revised and improved model, as did also the 4.82 c.c. 29.

Eight engines of five makes were sampled from behind the Iron Curtain during the year. In general, they leave the impression that, Czech speed specials notwithstanding, these countries have some way to go before they can offer any threat to Western standards. The best piece of workmanship came from East Germany in the shape of the Schlosser 2.5, followed by the Hungarian Alag X-3, the roughest was from Russia.

From the engines now on the American market, space allows us to mention two in addition to the Fox and we pick the Veco 19 and the Jim Walker Firecracker 0.065.

The Veco is one of the nicest engines we have ever handled. It is, we hear, becoming quite a favourite with radio men in the United States—understandably, in view of its smoothness, flexibility, easy starting and excellent output.

The Firecracker merits attention because of its unique pneumatically operated throttle consisting of an intake flap, supplemented by an exhaust butterfly valve, which gives very good control. This engine, incidentally, came as standard equipment with one of Jim Walker's Firebee model kits. The engine control is operated by means of tiny

(Continued on page 95.)

The 2.45 c.c. Webra Mach-1 in its new glowplug guise. Capable of delivering a useful output at extremely high r.p.m., this new Webra proved exceptionally easy to start and very smooth running.

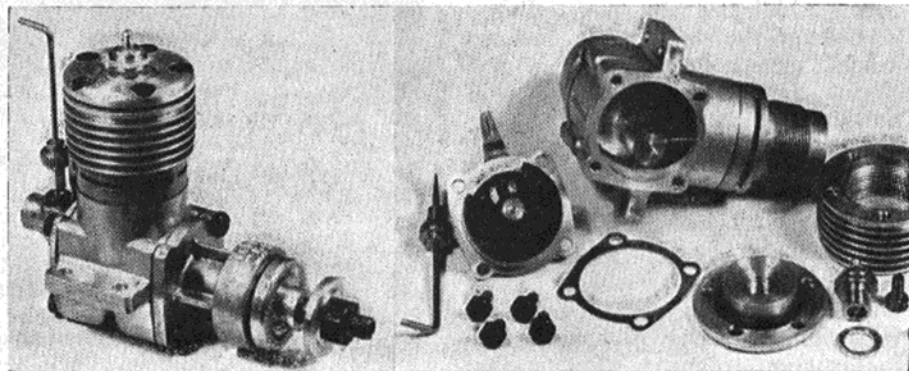

# Testing Rubber Motors

RON WARRING

tells you how, with a few simple tests, you can get the best out of your rubber motors

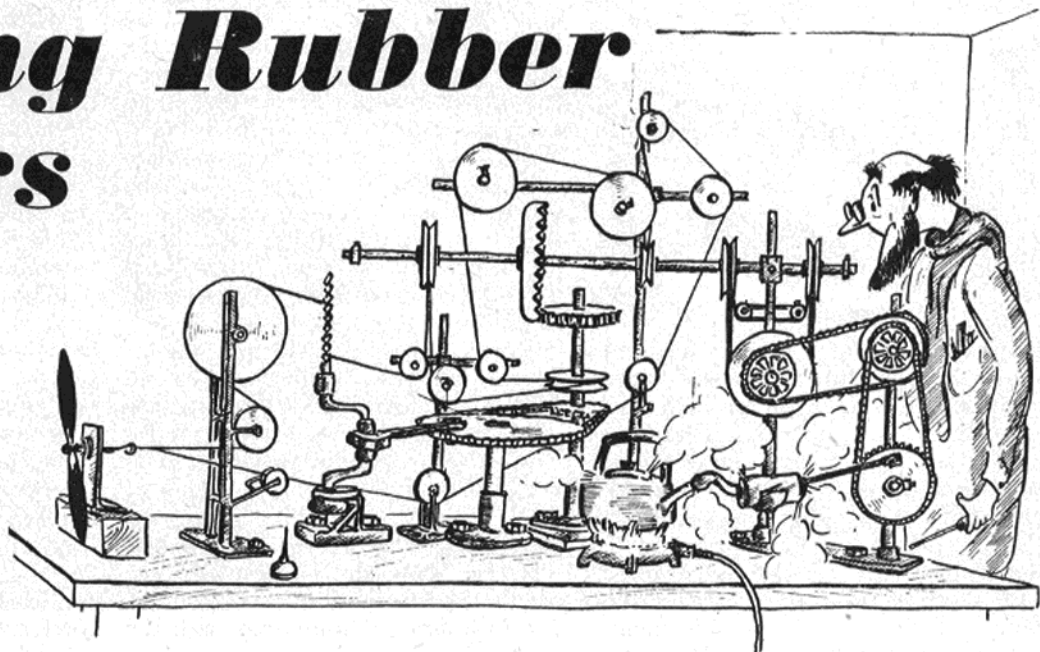

CHOICE of rubber strip is today somewhat limited, but it is just as important as ever to be able to assess the merits of a particular skein or batch of new rubber in order to decide on its suitability for contest work, etc. Slight differences in rubber quality can make all the difference to the performance of a model, and in preparing for an important contest it never pays to take chances in this respect.

The only way of bench testing rubber strip completely is to subject a made-up motor to a torque test. The apparatus required is quite simple, and can be made fairly easily. A counterbalanced, pivoted arm is mounted on a ply plate secured to a base block, the base being as long as the distance between hooks in the model, and fitted at the other end with a former to take the model's nose assembly complete with propeller.

When the rubber is wound up, torque generated by the motor produces a reaction through the rear hook (attached to the pivoted arm), tending to rotate this arm in the opposite direction. If this arm is

calibrated and a weight of suitable size is slid along it, a balancing position will be found where the yardarm weight/times distance from the centre, balances the turning moment (torque) of the motor. Thus the torque can be measured in simple units—ounce-inches.

With the propeller held, this is easy enough to do. The motor can be allowed to unwind a certain number of turns, the propeller held and a new torque reading obtained, and so on, until there are no more turns on the motor. The results can be plotted in terms of a *torque curve* showing how the torque stored in the motor diminishes as the motor turns are run off.

This is not a true representation since the motor is "static" when each reading is obtained. Such readings, in fact, are appreciably higher than *running* torque figures at the same intervals with the propeller spinning. But the latter can just as easily be determined by deliberately overweighting the torque arm so that the motor torque tends to lift this arm. Then the actual *position* of the torque arm at any instant is a

measure of the motor torque at that instant.

The amount of weight required at the end of the torque arm is easily determined. Just add enough for the arm to be lifted to a horizontal position when the motor is fully wound. If a balsa quadrant is cemented to the centre of the arm and fitted or marked out with a graduated scale, intermediate positions of the scale during the test are easily read off as scale figures. With such apparatus it is quite easy to read off "running torque" figures at 10 second intervals and have time to note them down before taking the next reading, then with a little practice, shortening to five second intervals.

Torque tests are very instructive, and certainly to be recommended for all modellers who take rubber flying seriously. They are easier to handle if two people can co-operate over the test, although they can be carried out single-handed, if necessary, by clamping the apparatus down securely to start with. They are most valuable if conducted with made-up, properly run-in motors of the size you would normally use in a particular model—whether an indoor model (when the torque testing gear would be made lighter and smaller, in proportion) or a Wakefield. By keeping a record of all such tests, important reference data can be accumulated.

For the modeller who wants a much simpler but still scientific approach, there is a method of testing by stretching sample lengths of rubber strip. This method has

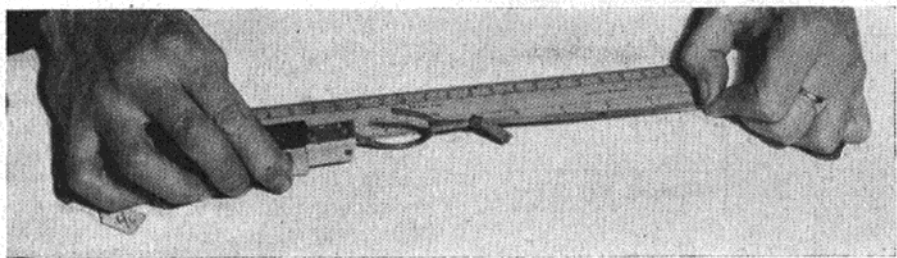

A spring balance and a ruler are all that is necessary for this pull test.



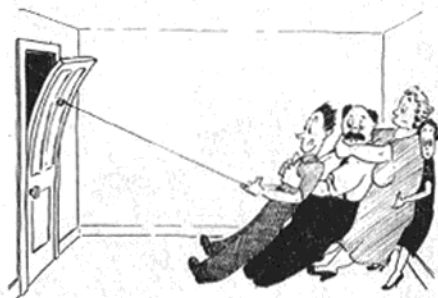

A simple pull test.

many advantages. It is quick and simple to operate and it uses only small lengths of rubber for each test. Also, since the rubber is not harmed by the test, it can be used to check the performance of a made-up motor already in use—e.g. to check if it has "fatigued" and is no longer suitable for contest work. If the same motor were checked on a torque rig for the same purpose, this would mean another winding for the whole motor, and an indoor job—an accurate stretch test can be made on the field.

This method was first described in the June, 1954, issue of MODEL AIRCRAFT (although the modulus figures in the accompanying tables were here misprinted and shown ten times too large). The principle is delightfully simple. A marked length

of strip—say 1 in.—is stretched by holding one end and hooking the other end over a spring balance capable of reading accurately up to at least 4 lb. The strip is held against a suitable scale (e.g. a ruler) and the value of the pull (i.e. the spring balance reading) necessary to stretch it to three times, four times, five times and six times its original unstretched length—in this case to stretch to 2, 3, 4, 5 and 6 in. is noted.

If you have already found similar figures for good rubber strip—e.g. rubber already giving satisfactory service in a model—test figures for new strip will show whether it is better (pull figures higher), or inferior (pull figures lower). Testing a rubber motor which has already had some use then, the figures will show whether performance has fallen off due to fatigue, if compared with the "new" figures.

The pull test will also show up the characteristics of rubber strip as regards initial torque and end torque, i.e. when the motor is nearing the latter end of its power run. High pull figures for six times stretch indicate that the rubber has a high initial torque. High pull figures for three times stretch indicate that the

rubber has good "end" power and performance will not fade right off after the first burst.

Pull figures will be lower for lubricated, broken-in rubber than for unlubricated rubber strip. The difference will show up most with the five times and six times stretch tests. There may be very little difference to note with a three times stretch test.

The main limitation of the stretch test is that it does not completely analyse the "working" performance of the rubber strip, and also small differences may be quite significant. For example, a difference of only ¼ lb. pull at six times stretch may mark the difference between good rubber and one with a relatively poor performance. So pull readings must be made as accurately as possible, at least to the nearest ounce, and preferably averaged over a number of individual tests.

Another way in which the pull test can be misleading is that it does not take into account differences in actual cross section. Although nominally of the same size, one sample of rubber may have a greater or lesser actual cross section, and perhaps be falsely judged superior, or inferior, because of the different volume of rubber which is actually being tested. It is easy enough to account for such differences in physical dimensions, however. If the pull test figures are divided by the actual cross section of the rubber (as measured) the results will be independent of the cross section. Such a figure is known as the rubber modulus and it will be appreciated that it applies equally to any size of strip. It is interesting to compare the performance of different sizes of the same brand of strip on a basis of calculating the modulus in each case. Quite often one size shows up better than another.

For modellers who want an even simpler test for new motors, then we can only recommend timing the power run with the new motor wound to, say, 80 per cent. full turns, using the propeller off the model. Then compare this time of running with that of an original (and satisfactory) motor with the same propeller and same number of turns. If the power run with the new motor is longer, then it is a weaker motor and will probably not give the performance required. If the new motor gives a shorter run, then perhaps it has not been fully broken in. If it has, then it is a more powerful motor—and you can then trim accordingly.

Typical Torque Curves Plotted from Fully Wound Motors

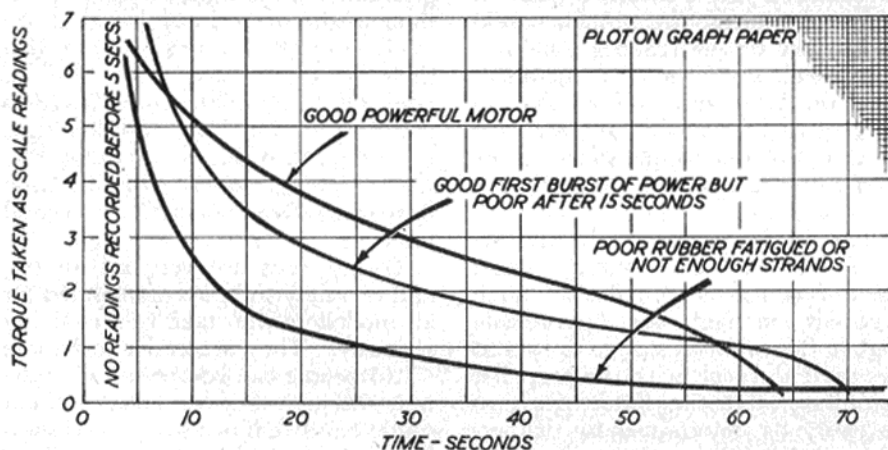

Typical Pull-test Figures with Table of Representative Moduli Values

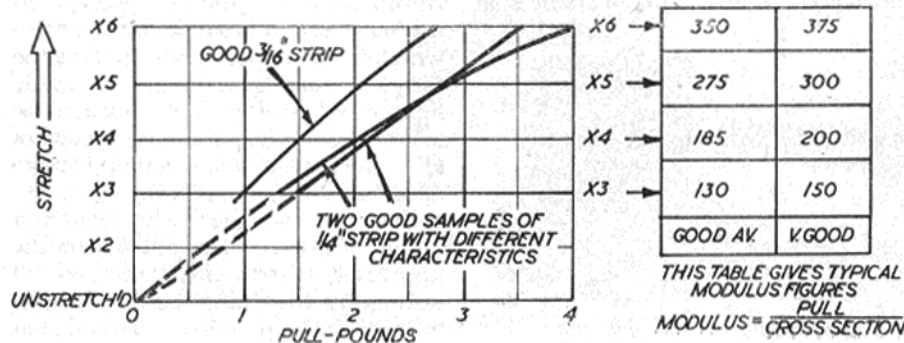

# the de Havilland TIGER MOTH

Build an authentic replica of the 'Moth' from these drawings and photos, which have been specially prepared for MODEL AIRCRAFT in co-operation with the de Havilland Aircraft Co.



"Flight" photo.

THE de Havilland D.H. 82 *Tiger Moth* first appeared in 1931 and in the past quarter-century has served as a basic trainer in air forces throughout the world, as well as being a popular aircraft for civilian use. In recent years a large number of *Tiger Moths* have been released from the R.A.F. to civil owners, to the particular benefit of flying clubs. Several thousand "Tigers" were built both in this country and abroad, with very few modifications to the original design.

The *Tiger Moth* was designed as an efficient primary, intermediate and advanced training aeroplane with tandem cockpits and controls, and instruments duplicated in both cockpits if required. Special equipment which could be fitted included a 10 gallon auxiliary petrol tank (forward of the front cockpit); bomb racks to carry four 20 lb. bombs, complete with release gear; bomb sight; camera gun; gun sight; Marconi A.D.22 wireless transmitting and receiving set; P.14 camera with slides; Handley Page automatic wing slots (with slot locking device operated from the cockpit); navigation lights; flares; metal airscrew; blind flying hood and associated instruments.

A seaplane version was also produced, whilst another variant was the D.H. *Queen Bee*, a radio controlled pilotless target aircraft equipped for catapult launching and with slings for recovery. Main distinguishing features of the *Queen Bee* were the covered-in cockpits and the large four-bladed wind generator mounted on the port side of the fuselage near

the front centre section strut. *Queen Bees* were produced in both landplane and seaplane form.

Structurally, the *Tiger Moth* has a rectangular steel tube basic fuselage to which is attached side stringers and a rounded top decking or turtleback. The engine cowling forward of the front centre section struts is of metal. Early "Tiger" fuselages had wire braced rear fuselages (R.A.F. machines J9922 to J9933 only), but all later machines had an all welded rear fuselage with 'N' bracing. The whole fuselage aft of the metal cowling is fabric covered.

The wings are of equal span, but differ slightly in trailing edge shape approaching the roots, and also very slightly in the amount of sweepback, when rigged. Sweepback is correctly determined at the interplane strut position datum line, measured from the leading edge (see layout drawing). The position of this datum line is clearly defined as the centre of the compression struts between the spars at that point.

Mainspars of the wings are of spruce spindled to an I-beam section, with built-up spruce ribs. Tips are of

metal tube, tip ribs being anchored to the outline by clips secured with woodscrews. All dimensional data as regards rib spacing, etc., are authentic as given.

Operation of the ailerons (on the lower wings only) is clearly indicated on the drawing, the horn and push rod being external and the lower part of the actuator disc being visible from the underside of the wings. The wings are fabric covered. Bracing wires spread in 'V' fashion, due to the stagger and sweepback, and their correct attachment points, should be noted.

Note the N-shaped centre section struts and the bracing arrangement of the undercarriage.

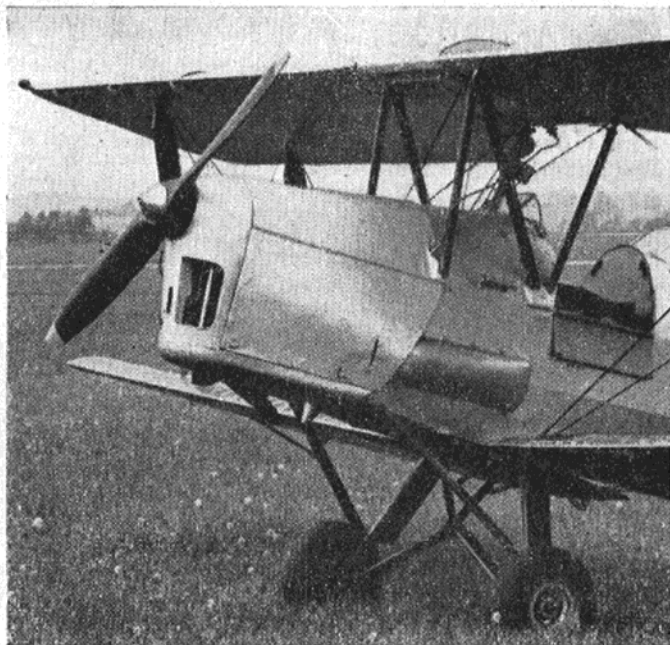



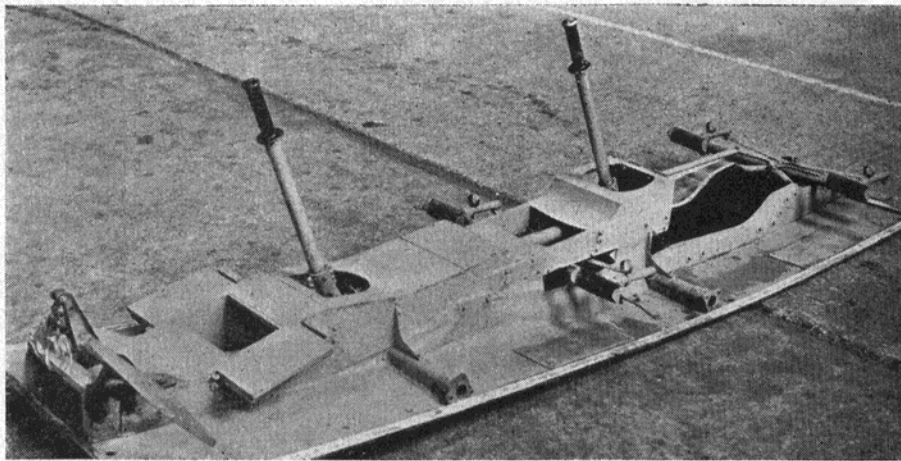

The "control system" before installation in a "Tiger Moth."

The tailplane leading edge consists of a laminated wood outline, locally reinforced at the strut attachment point and fishplates at the tip-spar joint. The elevator cable to the upper elevator horn (or bracket) passes through a fairlead bolted to the leading edge of the tailplane, after covering. The tailplane virtually sits on top of the fuselage and is rigged parallel with the top longeron.

The main drawing shows the position of typical civilian registration markings on wings and fuselage. In

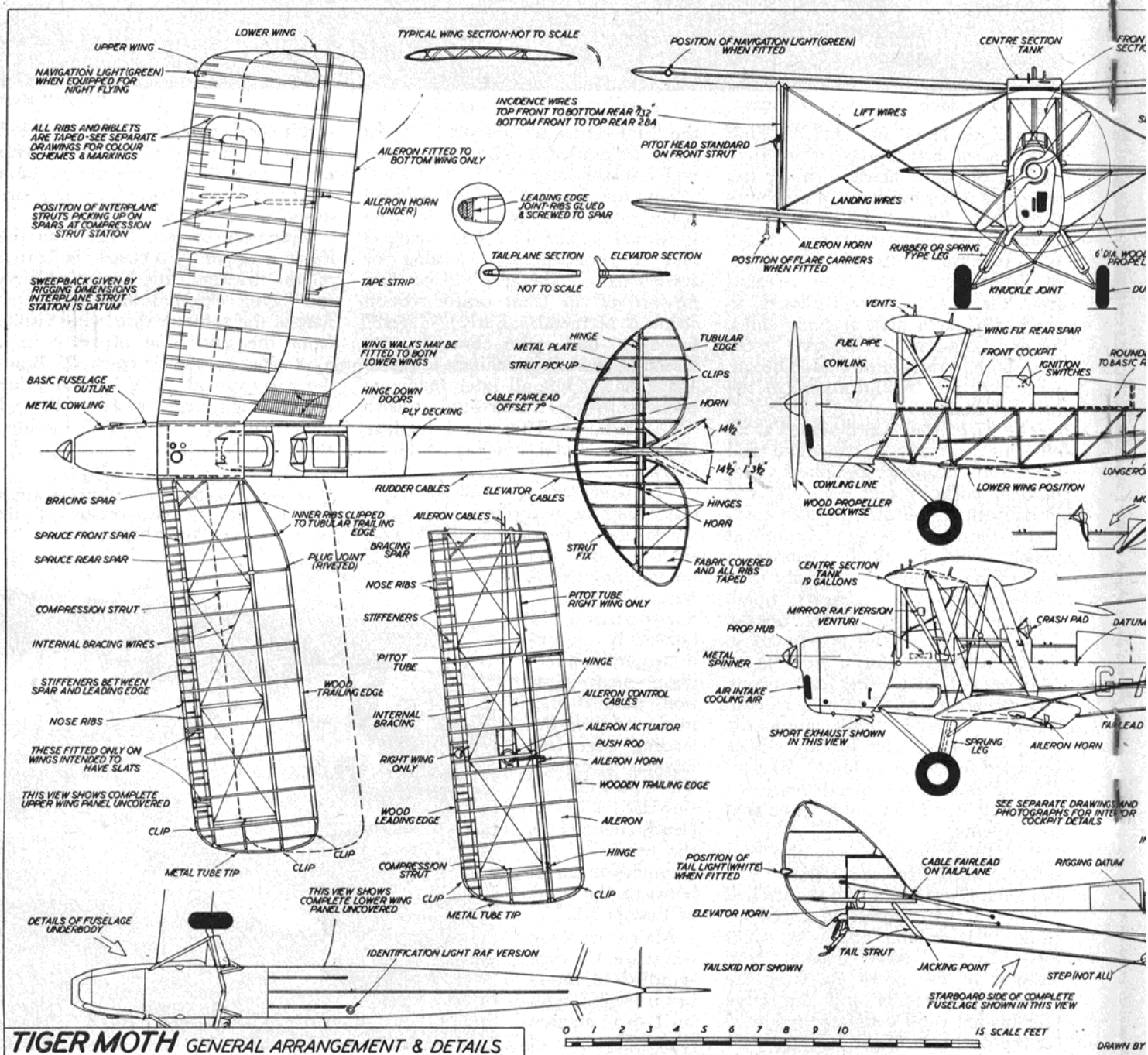

the latter case the letters are run parallel with the top longeron. A separate detail drawing is given of a complete R.A.F. colouring and marking scheme. Late R.A.F. machines, too, commonly had the anti-spin strakes fitted to the top of the fuselage running along to the leading edge of the tailplane. These strakes were not normally fitted to civilian aircraft, but many ex-Service aircraft now in civilian use may retain this fitting.

Other small details may vary with different aircraft. On all the earlier R.A.F. *Tiger Moths* fuselage steps  
(Continued on page 91.)

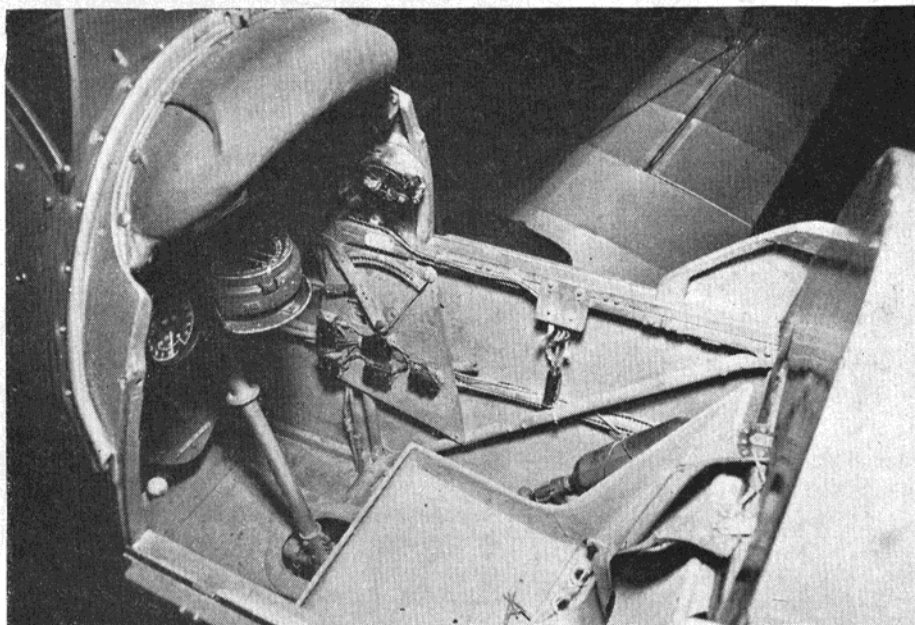
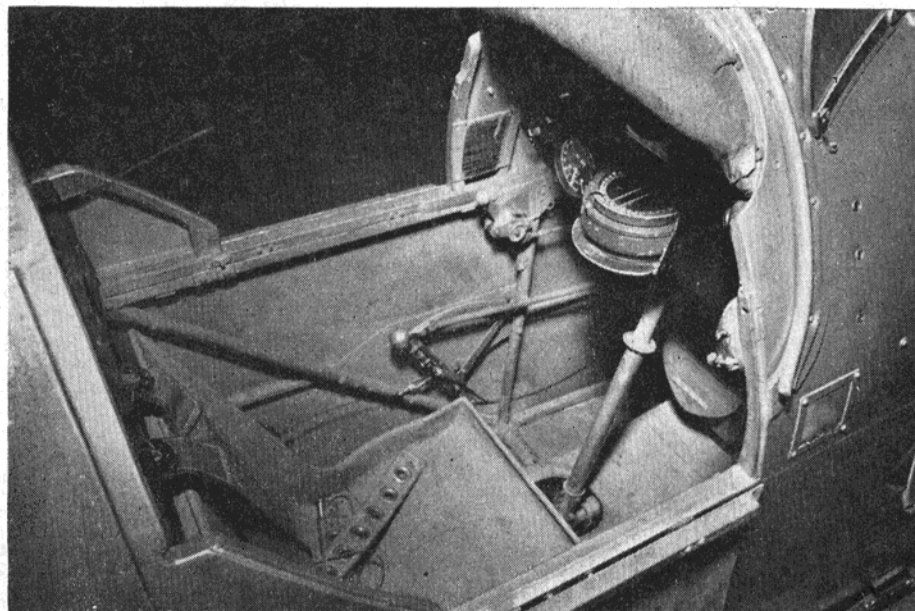

The cockpit of the "Tiger Moth" is essentially simple in its equipment, as befits a basic trainer. Clearly visible are the control column, compass and altimeter. In the top view the throttle is just below and to the right of, the cockpit door, while the larger lever lower down is the "tail trimmer," which actually operates a spring loading on stick. In the lower photograph the morse key is just below the crash pad on the starboard side, while below that is a larger lever that locks the automatic slots. At the side of the seat is the fire extinguisher.

Below : Three "Tigers" of the Midland Aero Club, with G-AFNP (shown on the plan) in the centre.

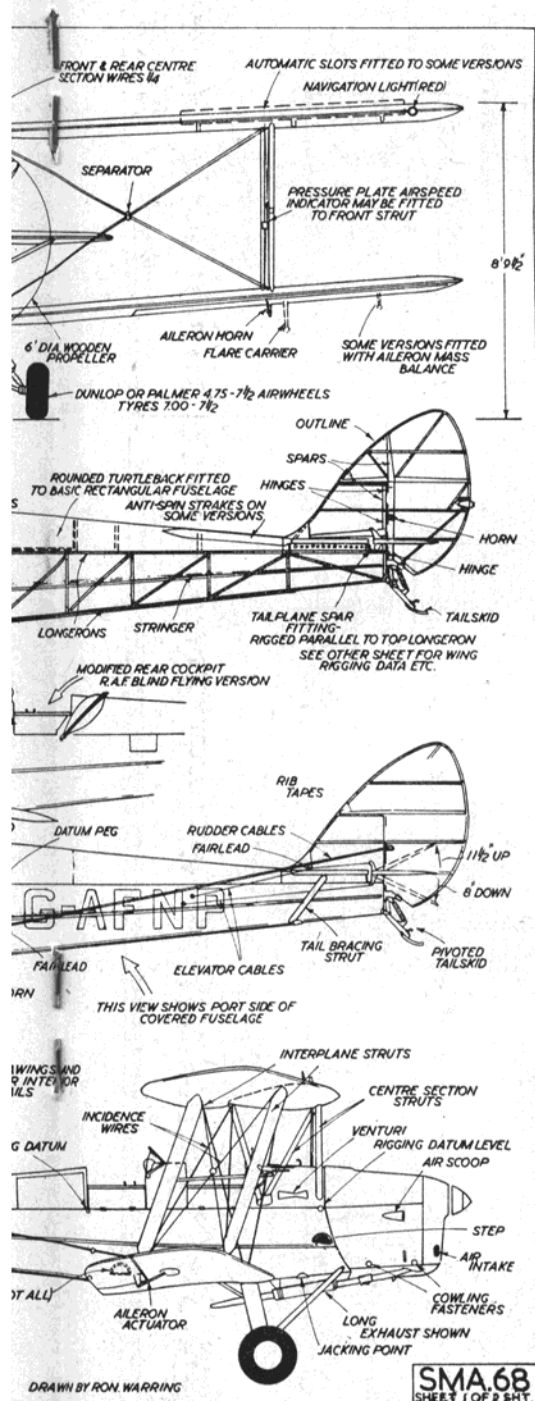





were common for entry into the cockpits (from the right-hand side). Wing walks appear to have come into widespread use later for entry from either side. The step in the fuselage just behind the cowling on the right-hand side was for access to the centre section tank filler. The front cockpit cannot be entered

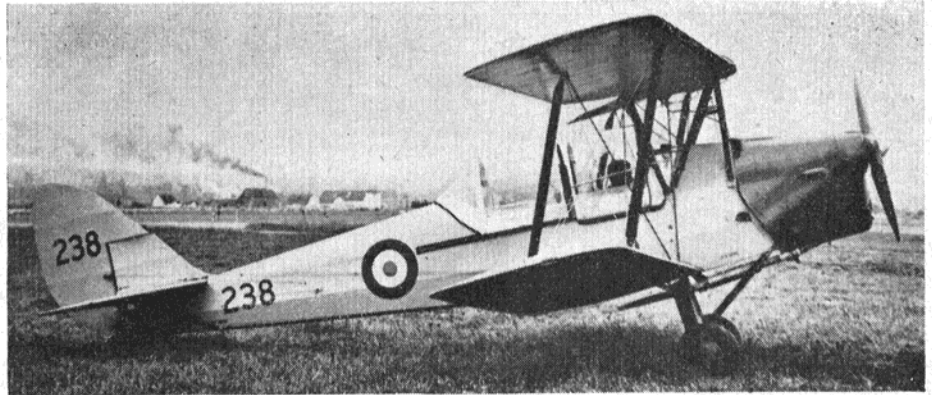

"Tiger Moths" built in Canada are distinguishable by the cockpit canopy. Designation is DH.82c.

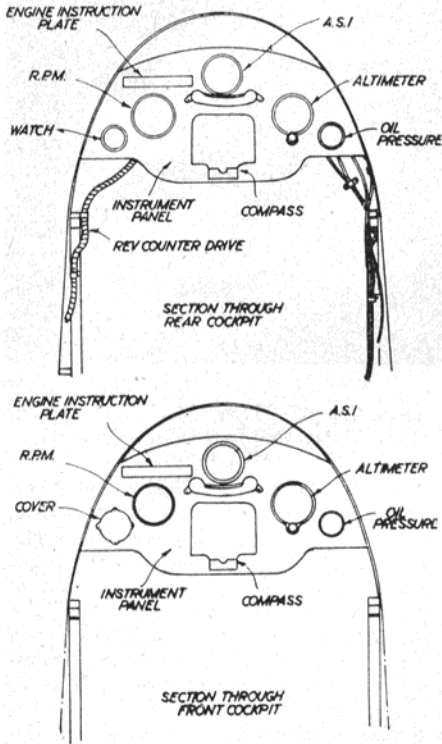

from this position as the bracing wires come in the way.

The instrument panels detailed in the drawing are of basic type (1938 period). Considerable alterations were made later, including even complete regrouping of the instruments on the panel as well as the addition of further instruments. The cockpit detail photographs reveal some of these differences, these being of an R.A.F. aircraft with rear cockpit doors slightly modified to take the blind flying hood. A further and more extensive modification of the cockpit arrangement is seen in another photograph of a Canadian built *Tiger Moth* with completely enclosed front and rear cockpits with sliding canopies.

### COLOUR SCHEMES

Apart from the many hundreds of civilian *Tiger Moths* still flying—all with highly individual colour schemes—the R.A.F. machines offer a wide choice of finish. (Continued on next page.)

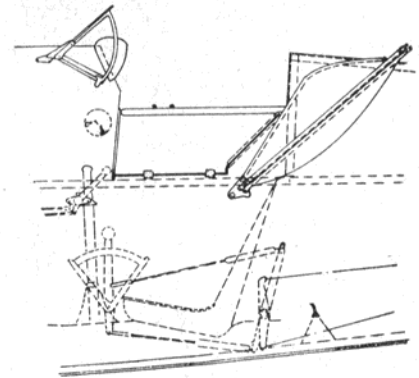

## Facts and Figures

Performance of Standard *Tiger Moth* without extra external equipment

	Landplane			
	Normal weight		Maximum weight	
	1,650 lb.	750 kg.	1,825 lb.	829 kg.
Maximum Speed:				
At sea level ... ..	110 m.p.h.	177 km./hr.	109 m.p.h.	175 km./hr.
At 5,000 ft. (1,525 m.) ... ..	106 m.p.h.	170.5 km./hr.	105 m.p.h.	169 km./hr.
At 10,000 ft. (3,050 m.) ... ..	101 m.p.h.	162.5 km./hr.	99 m.p.h.	159 km./hr.
Cruising Speed at 1,000 ft. (305 m.) ... ..	94 m.p.h.	151 km./hr.	93 m.p.h.	149.5 km./hr.
Fuel Consumption at cruising speed ... ..	5.9 gal./hr.	26.8 lit./hr.	5.9 gal./hr.	26.8 lit./hr.
	15.9 m.p.g.	5.65 km./lit.	15.8 m.p.g.	5.6 km./lit.†
Ultimate Range				
With 19 gal. petrol (86.5 litres) ... ..	302 miles	486 km.	300 miles	482 km.
With 29 gal. petrol (132 litres) ... ..	460 miles	754 km.	458 miles	740 km.
Stalling speed ... ..	43 m.p.h.	69 km./hr.	45 m.p.h.	72.5 km./hr.
Length of run to take off ... ..	119 yd.	109 m.	156 yd.	143 m.
Time to take off ... ..	9 sec.		12 sec.	
Height at 500 metres from rest ... ..	188 ft.	57 m.	143 ft.	44 m.
Length of run landing ... ..	122 yd.	111 m.	133 yd.	123 m.
Gliding angle ... ..	1 in 7½		1 in 7½	
Rate of climb at sea level ... ..	798 ft./min.	244 m./min.	673 ft./min.	205 m./min.
Time to climb 5,000 ft. (1,525 m.) ... ..	7½ min.		9 min.	
" " 10,000 ft. (3,050 m.) ... ..	18½ min.		23½ min.	
Absolute ceiling ... ..	18,100 ft.	5,520 m.	16,000 ft.	4,870 m.
Service " ... ..	15,800 ft.	4,820 m.	13,600 ft.	4,150 m.



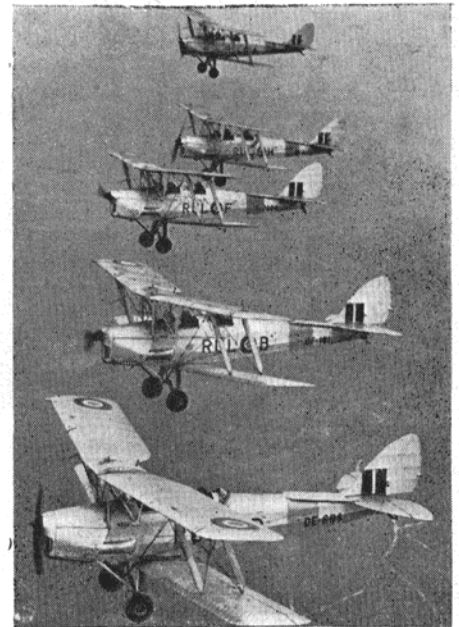
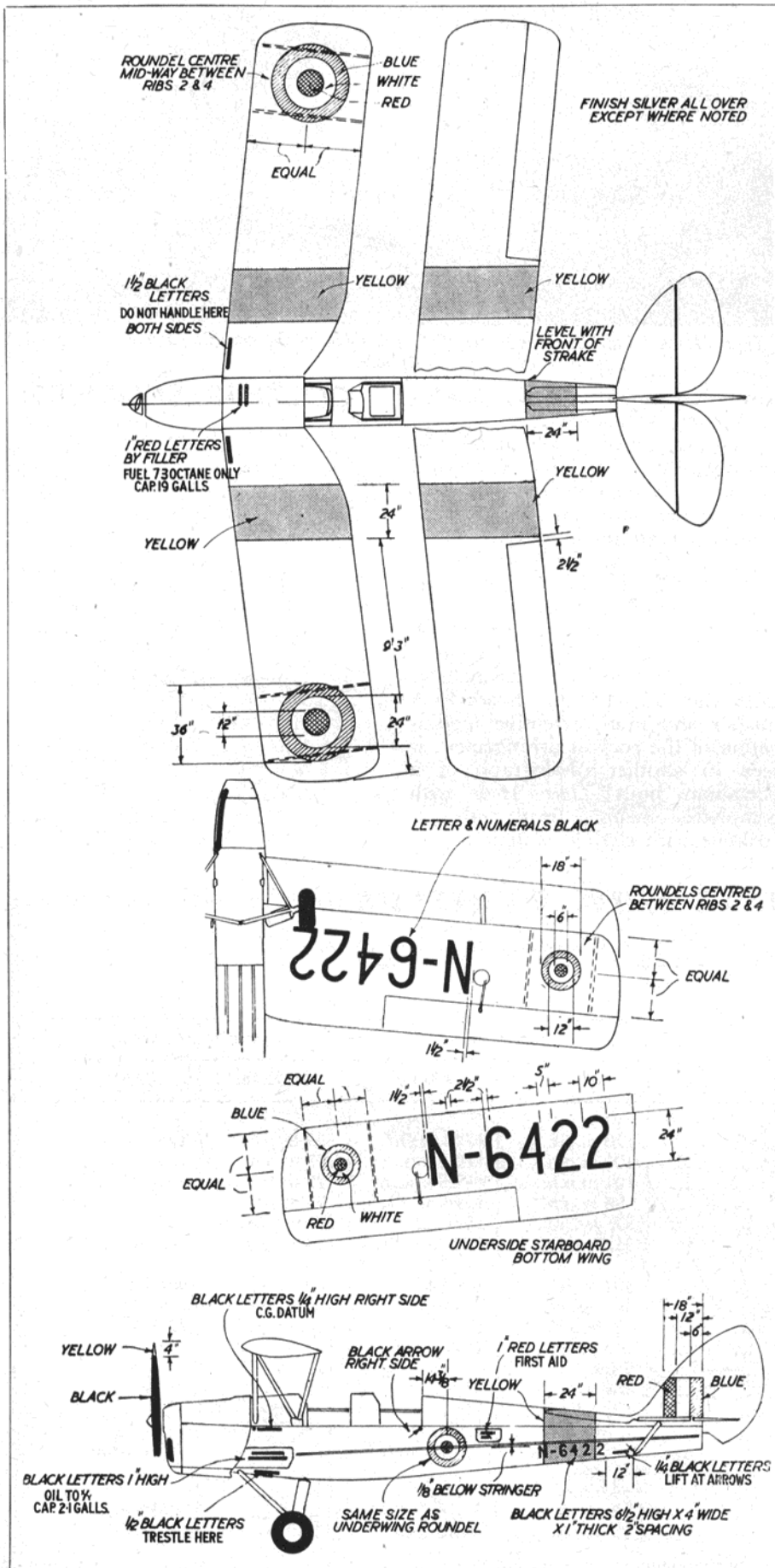

"Flight" photo

A formation of "Tiger Moths" in typical R.A.F. finish standard after mid-1942.

Pre-war Tigers were finished in yellow overall, and in fact this scheme was continued in the first few months of the war. However, until December, 1940, *Tiger Moths* operating within reach of the Luftwaffe were camouflaged on the upper surfaces to a point half-way down the fuselage. After this date the camouflage was carried to the bottom line of the fuselage.

Serial numbers were in black on the yellow undersurfaces, and it is interesting to note that the hyphen between the letter and the number was peculiar to de Havilland aircraft.

A typical post-war silver finish for the *Tiger Moth* is shown in the drawing opposite. As always, reference to photographs is advised for details of individual markings.

R-5130 here displays the colour scheme in use during the first year of the war—camouflaged upper surfaces—yellow below.

"The Aeroplane" photo

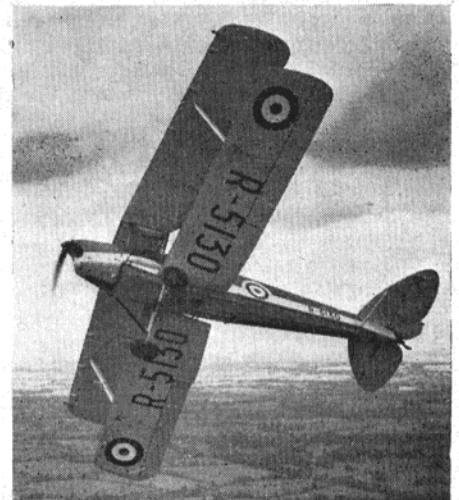
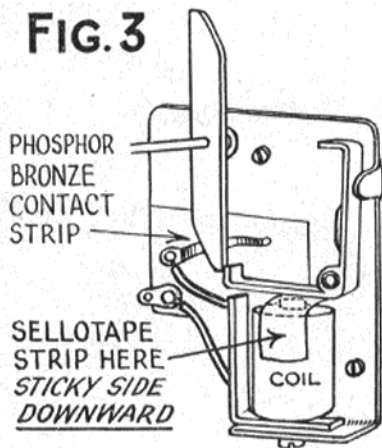

FIG. 3



### Actuator

The self-neutralising two-pawl type is by far the most popular and reliable. Being robust, it needs little attention, but the following points should be watched.

Make sure that the drive is dead straight through the rubber motor, actuator spindle and crank. Bearings must never be tight—slight “sloppiness” is preferable. The crank must move easily, with slight play, in the rudder loop, with the bend 100 deg., not 90 deg., so that it follows the angle of the loop as the rudder moves to left or right (see Fig. 2).

See that the cross-arm makes light but positive contact with the phosphor-bronze strip (in the usual current-saving types) to ensure full magnetic pull on signal. Clean the points of contact occasionally, as these tend to develop a sort of “metallic grease” through constant friction.

To prevent the possibility of metal-to-metal contact between the pawl and the magnet pole, place a strip of Sellotape (sticky side *downwards*) on top of the magnet pole (see Fig. 3). This effectively prevents the possibility of a stuck-on rudder through residual magnetism holding in the pawl even after cessation of signal.

The normal working voltage is  $4\frac{1}{2}$  V,

FIG. 5

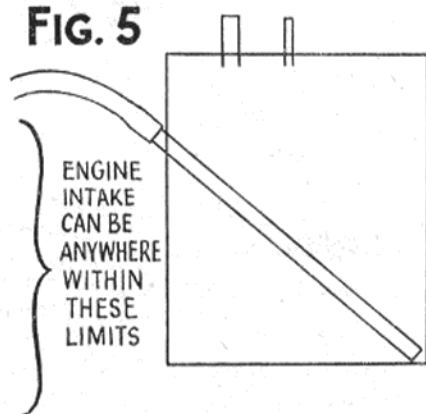

but I always use 6 V. which not only gives a much healthier and stronger pull, but also provides a much higher margin of safety against failure to respond through batteries running down during a long flight.

### The Model

For consistent radio flying, your model **MUST** be strongly built, with the strength in the right places. Never end any reinforcement abruptly, but taper off from the stronger to the weaker part (see Fig. 4). At the same time, flying surfaces must be free to knock off easily on impact to prevent breakage. I have found two-piece strutted wings the answer to this problem, to which I have now added a removable centre-section so that no openings are required in the cabin sides.

Use adequate engine power. You can't expect a heavily-loaded model to make any useful penetration otherwise. For models up to  $3\frac{1}{2}$  lb.

soaked rag after each flying session before putting away.

### Flying

Always check radio response before launch. This must be **PERFECT**, with no sticking, spinning or skipping. If there is the slightest doubt, stop the motor and find the trouble before attempting a flight. You just **CANNOT** afford to “take a chance” with R/C. A stuck-on rudder is bound to cause disaster; failure to respond almost always means a fly-away; intermittent or unreliable response results in a worrying, unsatisfying flight even if you get away with it.

With the long engine-runs which are normal in R/C flying, there is always the danger of a fly-away, even with the best care in the world, through something going wrong after launch. The answer is not to reduce engine-runs to ridiculously short periods (which would be a negation

FIG. 4

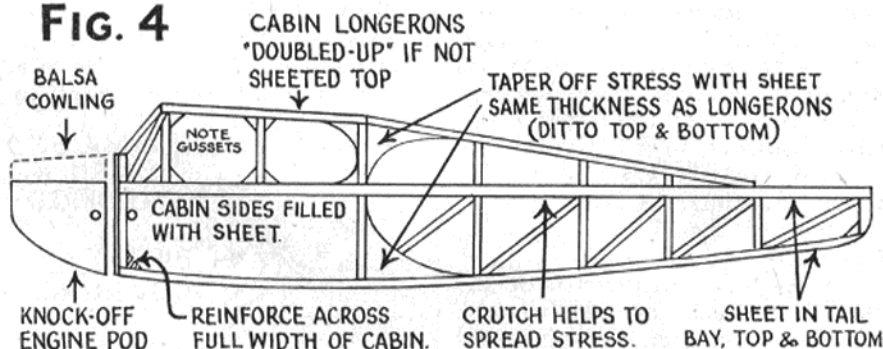

all-up weight use a *good*  $2\frac{1}{2}$  c.c. motor; for models up to 5 lb., a *good*  $3\frac{1}{2}$  c.c. Add downthrust if needed to eliminate any power-stalling.

Engine pods should preferably be knock-off and very strongly constructed. Mine are all ply, cemented and screwed. Undercarriage must be strong but never, repeat **NEVER**, rigid, otherwise it will constantly need straightening and will often tear right out of the fuselage causing considerable damage. Some form of springing must be incorporated, such as spiral spring, torsion bar or swinging arm.

To ensure constant feed to motor in dives, stunts, etc., use a suction-feed tank (see Fig. 5). When starting motor, fill feed tube by flicking over motor several times with finger closing air intake.

Thoroughly fuel-proof entire model with four or more good coats of dope until a glossy air-tight surface is obtained. Wipe clean with a petrol-

of the thrill of R/C flying) but to insure your model against loss by o.o.s. flight. Then, if the model is not found, you will be provided with the necessary cash to build and equip another.

Finally, fly with care. This means that you should take no unnecessary risks with your own or other people's safety. Make sure the launching area is clear of spectators so that if the model should dive-in, no injury will be caused. If you are trying stunts, make sure the model is over open ground, with no one underneath. A heavy radio model diving under power can be a truly lethal weapon capable of causing serious injury.

And so we come to the end of the series. I hope that it has provided interesting (and sometimes amusing) reading, and that the lessons I have learned will be of some assistance to others embarking on (or already indulging in) this most fascinating and satisfying branch of model flying.



## SPOOK EXPOSED

See page 72

**E**ASY, isn't it, when you compare the two photographs? Here, Lt.-Cdr. Stuart Soward of the Royal Canadian Navy shows the illuminated suit he has devised for use by "batmen" guiding aircraft making night landings on the deck of H.M.C.S. *Magnificent*. The picture on page 72 shows what the suit looks like to a naval pilot approaching the carrier for a night landing—although it would appear much smaller, we hope!

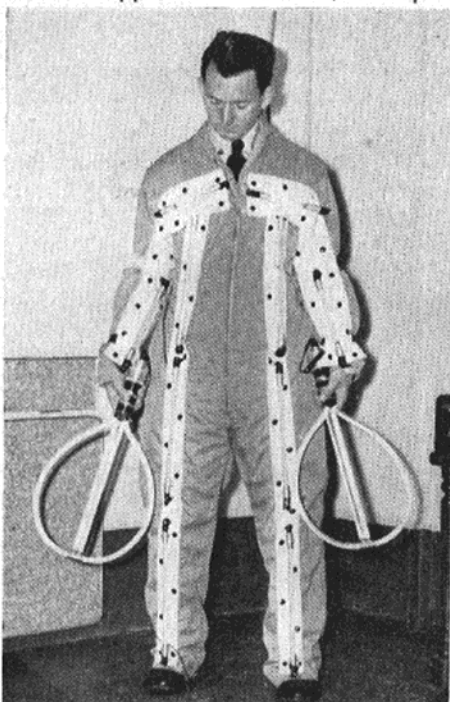

This brilliant (yes, we know!) idea won for the Commander a 200-dollar award and a commendation from the Chief of Naval Staff.

## Engines Only

Continued from page 84

air bellows mounted on the crankcase which are connected, via a short rubber tube, to a length of small bore Neoprene which goes back, with the control-lines, to a bulb attached to the C/L handle. A remarkably ingenious device and one which could readily be adapted to R/C use with a small model. The *Firebee* kit is no less remarkable for its completeness.

Back home, the astonishing output of the Allen-Mercury 10 is still being talked about, while the new, attractively priced Frog 80 introduced just before the end of the year is featured in our test report in this issue. Just now we also have a couple of E.D. prototypes, 1.5 and 2.5 c.c., both with reed-valve, which look likely to have something to offer in 1957.

## M.A.'s "Easy 8"

## Two Guineas goes to the winner of our easy Cash Quiz Contest

Entries must reach us by February 28th—the first "all correct" line opened on that date gets the prize. It's as simple as that!

Address is "Model Aircraft," 19-20 Noel Street, W.1

1. One of the following aircraft is NOT represented in this collection of solid models. Which is it?

- (a) Gloster Meteor
- (b) Gloster Javelin
- (c) Bell X-2
- (d) Supermarine Spitfire

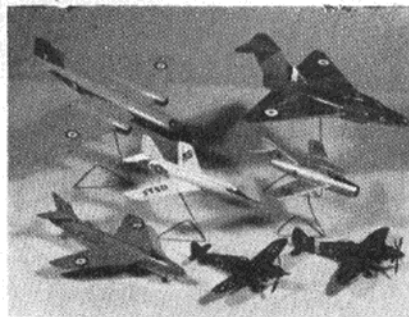

2. The following anagrams represent the names of well known British model builders. Rearrange the letters to find these names and then name the world champion among them:

- (a) SIR BYBAG
- (b) MR SAYNOK
- (c) DON JOHN LENOL
- (d) ED PAVENORS

3. This free-flight scale model is of one of the following light aircraft:

- (a) Luscombe Silhouette
- (b) Cessna 170
- (c) Auster Autocar
- (d) Piper Pacer



4. The Wakefield International Trophy Contest was first held in:

- (a) 1921
- (b) 1928
- (c) 1935
- (d) 1942

5. The proposed new F.A.I. power loading for engine-driven models, for 1958, is:

- (a) 7.06 oz./c.c.
- (b) 9.96 oz./c.c.
- (c) 10.58 oz./c.c.
- (d) 14.12 oz./c.c.

6. This 3.2 c.c. model glowplug engine comes from:

- (a) Great Britain
- (b) U.S.A.
- (c) France
- (d) Japan

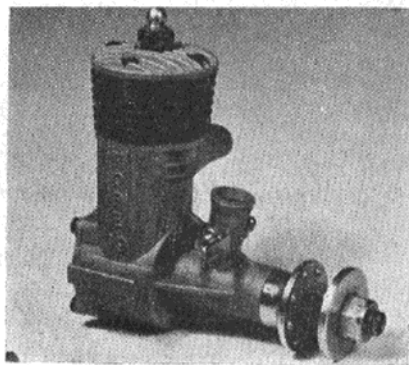

7. One of the four makes of British engines below has appeared only as a diesel—never with glowplug ignition. Which is it?

- (a) Amco
- (b) Allbon
- (c) Frog
- (d) Mills

8. The Monoline control system is the invention of:

- (a) Jim Walker
- (b) Victor Stanzel
- (c) Harold deBolt
- (d) Leo Holliday



**CONVAIR WERE NOT KIDDING** when they named their new B-58 bomber the *Hustler*. Slide-rule experts have calculated that its four afterburning General Electric J79 turbojets, producing around 18,000 lb. thrust each, should give a combat speed of up to Mach 1.8—say 1,200 m.p.h. at height. It is supersonic without afterburning and has outpaced a *Super Sabre* during flight tests.

Virtually a scaled-up F-102 with podded engines, the B-58 spans only 55 ft. and is 95 ft. long. Its wings have a 4 per cent. thickness/chord ratio and the leading edges are cambered progressively towards the tips, which reduces induced drag at subsonic speeds without penalty above Mach 1. Control is through elevons and rudder, with spoilers forward of the elevons and small trim tabs inboard of them. Each main undercarriage leg has an eight-wheel bogie, and a braking parachute is housed under the tail end.

The slim fuselage has an area-rule wasp-waist, with the crew of three in tandem at the front. Also area-ruled is the 50-ft. long, 8-ft. wide under-fuselage weapons pod which forms the other half of the B-58 Weapons System and which can house alternative loads of bombs, reconnaissance cameras, radar countermeasures equipment or even

air-to-air missiles for use in an all-weather interception role.

**ANOTHER HUSTLING AMERICAN** is the U.S. Navy's Grumman F11F-1F *Tiger* lightweight interceptor, which may have had a crack at Britain's year-old world speed record by the time this is printed. Helped by an area-ruled fuselage and the urge of a J79 turbojet and afterburner instead of the normal J65 Sapphire, a *Tiger* is said to have achieved a speed of 1,220 m.p.h. in straight and level flight at 40,000 ft. and an altitude

Its fixed armament comprises four 20 mm. cannon, but it will almost certainly carry also the new Sidewinder missile.

Wing span is 31 ft. 7½ in., length 42 ft. and normal weight with four 20 mm. cannon 13,850 lb.

**HUSTLER NUMBER THREE** is Sikorsky's big HR2S-1 (S-56) helicopter which celebrated the 181st birthday of the U.S. Marine Corps last November by setting up three new international records. Most spectacular was a speed run of 162.7 m.p.h. without payload; the



of over 72,000 ft. during development trials.

The *Tiger* illustrated (above) is a standard production F11F-1, with J65 and a retractable flight refuelling nose probe.

others being climbs to more than 12,000 ft. with a 5,000 kg. (11,050 lb.) load and to 7,000 ft. with 6,000 kg. (13,250 lb.), which beat one of the records set up last year by a Russian tandem-rotor YaK-24.

Left: The Vickers "Vanguard." Right: The only "Stratocruiser" in service with the U.S.A.F.





The latest photograph of the 26-seat HR2S-1 (below) shows that the main rotor fairing has been lengthened, the tail rotor boom narrowed and the horizontal stabilisers reduced in chord since the prototype first flew. External fuel tanks are also fitted and some of the engine cowling panels are left off, presumably to assist cooling of the 2,100 h.p. Pratt Whitney R-2800 radials.

\* \* \*

**The JET v. TURBOPROP BATTLE** took an interesting turn



This U.S. Marine Corps helicopter, the Sikorsky HR2S-1, last year set up three new international records

when Trans-Canada Air Lines ordered 20 Vickers *Vanguards*, worth over \$67 million. The contract was signed only after a two-year study which convinced T.C.A. that this aircraft is a better bet economically than any of the projected new medium-range U.S. jet-liners or the *Electra*, even when the latter is fitted, like the *Vanguard*, with four Rolls-Royce Tyne turboprops.

T.C.A.'s *Vanguards*, for delivery in 1960, will have an all-up weight of 141,000 lb., and an effective range of 1,750 miles with full 24,000 lb. payload in the worst Canadian winter conditions. Powered by 5,315 c.h.p. Stage 2 Tynes, they will cruise at better than 420 m.p.h. at 20,000 ft. with 82 first-class or 102 tourist passengers, and will have pressurised cargo space for up to ten tons of freight in the lower half of their "double-bubble" fuselage.

\* \* \*

The photo (left) was obtained when the one and only U.S.A.F. *Stratocruiser* dropped in to Boeing's factory on a visit recently. Now designated VC-97B, it is the YC-97B formerly operated by M.A.T.S. and is the only C-97 type with full airline passenger furnishings. Complete with star-spangled Strategic Air Command fuselage band, it is assigned to the H.Q. Eighth Air Force of S.A.C. at the Westover Air Force Base, Massachusetts.



A smart paint job like this would look well on a model Pacer. (M.A. Plan 227)

**LEARN AS YOU TRAVEL** is the Piper way of attracting new customers. Businessmen planning a trip are invited to phone their local dealer to hire a four-seat *Tri-Pacer* at moderate cost and to fly to

Pipers say that thousands have learned to fly in this way, going solo after six to ten flying-and-working hours and taking their licence after 35 hours. Alternatively, anyone buying a *Tri-Pacer* is offered free all the instruction needed to solo, for cross-country flying and periodic checks.

\* \* \*

Present equipment of the new **WEST GERMAN LUFTWAFFE** consists of 32 Republic F-84F *Thunderstreaks*, 20 Piper L-18 *Super Cubs*, 29 North American T-6 (*Harvard*) trainers and some dual-control Lockheed T-33 *Shooting Stars*.

**FROM THE PAST . . . . . No. 10**

**The Sikorsky Le Grand**

**T**HE *Le Grand* Biplane built by Igor Sikorsky at Petrograd in 1913 was as remarkable as any of the helicopters which have since made him world-famous. First four-motor aircraft in the world, it was flown on May 13th, 1913, with its 100 h.p. four-cylinder water-cooled Argus engines mounted in tandem pairs. The rear engines were later moved outboard in a conventional four-tractor layout to improve propeller efficiency.

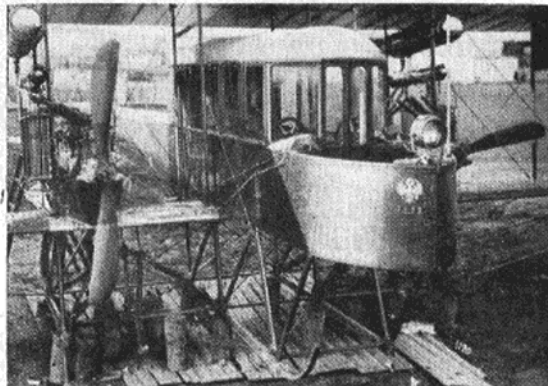

*Le Grand* had a loaded weight of about 9,000 lb. and spanned 92 ft. Its main landing gear of four-wheeled bogies was supplemented by skids. And it was by far the most luxurious aircraft of its day. At the front of the fuselage was a large balcony, complete with searchlight. Next, through a glass-panelled door, came an enclosed cabin for the aircrew, with two seats, dual controls and a full 1913 range of flying instruments. Through another door to the rear was the main passenger cabin, furnished with four seats, a sofa and table, with sufficient headroom for the passengers to stand, and lined

along both sides with large windows. Finally, there came a washroom and wardrobe.

From the start, *Le Grand* flew well, its test flights including one of 1 hr. 54 min. duration carrying eight persons. It made altogether 53 flights and was demonstrated to the Czar, who presented Sikorsky with a gold watch bearing the imperial eagle. From it were developed the even larger *Ilya Mourometz* four-motor bombers, of which 75 were built and used in action by the Russian "Squadron of Flying Ships" during the first World War.

# The FROG 80

0.8 c.c. DIESEL MOTOR

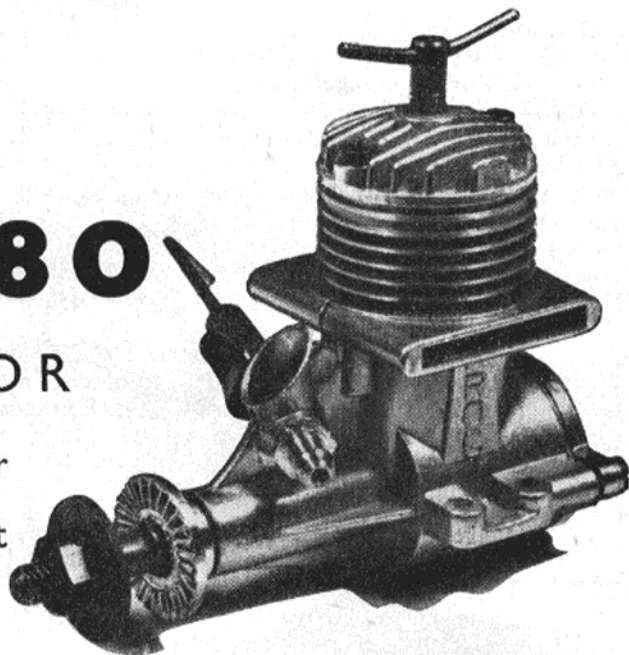

THE latest entirely new British engine to reach the market is the Frog "80" diesel. This model will replace the well-known "50" model and we have no hesitation in saying that it is a better engine in every respect.

In fairness to the "50," it must be remembered that this engine was introduced at a time when several makes of 0.50 c.c. diesels were being put on the market in the expectation that this would eventually develop into a new and popular small class.

In actual fact, beyond some initial enthusiasm, the reception of the 1/2 c.c. engine by the modelling fraternity was not encouraging and one of the reasons for this may well have been that 1/2 c.c. diesels, as a group, are not among the easiest handling small motors and by no means the best choice for a beginner. It is a fact that diesels appear to be most successful between certain limits of capacity—which can be roughly defined as being approximately

"has a number of out-of-the-rut features"

between 0.75 c.c. and 2.5 c.c.

On the basis of power per unit of cylinder capacity, the "50" was a good performer and the "80," size for size, is no detectable improvement on this, but its starting, general behaviour and running qualities are most certainly superior to those of the earlier model.

In appearance the Frog "80" is an attractive little motor of well-balanced proportions and good finish. It is of the conventional shaft-valve, reverse-flow scavenged cylinder layout, but has a number of out-of-the-rut features.

The first of these is the synthetic rubber O-ring fitted to the contra-piston. This makes the "80" the only non-American unit to be so fitted up to the present time. When O-rings first appeared on the American McCoy and Cub diesels, some ill-conceived criticism was directed against them in this country which our personal experience forced us to refute. Now, four years later, we have no reason to change our opinion.

The main reason for the adoption of the O-ringed contra-piston in place of a ground contra-piston, is, of course, economy in manufacture. This, for no apparent reason, appears to have led to the assumption, in some quarters, that the O-ring is an inferior means of achieving the required

compression seal and/or that it wears out quickly. In fact, a well-designed O-ringed contra-piston has as good, or better, compression seal, by comparison with conventional contra-pistons, while the life of the ring is certainly at least as many hours as the most enthusiastic modeller will run his engine in the course of a whole season—added to which the ring is, in any event, a very cheap and simple replacement. In the case of the O-ring used on the Frog, the manufacturers, the Burtonwood Engineering Company, consider that the average life should, in fact, be in excess of 100 hours.

Like the American diesels mentioned, the Frog "80" also uses a non-metallic thread insert in the cylinder head (in this case of nylon) which effectively prevents the compression lever from working back with vibration—an annoying habit with some engines that sometimes results in the lever being jettisoned in flight and lost.

Other features of the motor include the short stub exhausts to aid cowled installations and the angled, right-hand needle-valve assembly. The "80" is for beam mounting, but can be adapted to bulkhead mounting via the threaded lugs which secure the backplate.

### Specification

Type: Single-cylinder, air-cooled, reverse-flow scavenged two-cycle, compression-ignition. Shaft type rotary valve induction.

Swept Volume: 0.0493 cu. in. (0.807 c.c.).

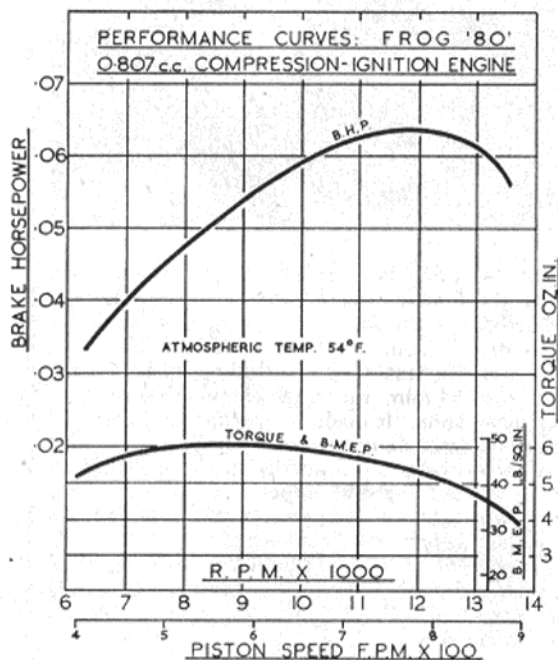



Bore : 0.400 in. Stroke : 0.392 in.  
Stroke/Bore Ratio : 0.98 : 1.  
Compression Ratio : Variable.  
Weight : 2.0 oz.

#### General Structural Data

Tumbled pressure-diecast LAC.112A aluminium alloy crankcase and main bearing with integral intake, exhaust ducts, etc. Disc-web crankshaft of Phoenix case-hardening steel, hardened and ground on journal and crankpin and with splined hub fitting. Brico cast-iron piston with full-floating gudgeon pin and forged dural connecting-rod. One-piece cylinder with integral cooling fins, in Phoenix case-hardening steel, hardened, ground and honed. Diecast LAC.112A alloy finned cylinder head with nylon thread insert. Cylinder components retained by two long screws into crankcase lugs. Flanged contra-piston of mild steel with Burtonwood extra-high-duty synthetic rubber O-ring. Spraybar type needle-valve with spring ratchet. Beam mounting lugs.

#### Test Engine Data

Running time prior to test : two hours.

Fuel used : 40 per cent. technical ether BSS.579, 30 per cent. kerosene, 28 per cent. Castrol "M" castor-base oil, 2 per cent. amyl-nitrate.

#### Performance

Starting characteristics of the "80" are good on practically all suitable prop sizes. Starting up a new engine from cold for the first time may take

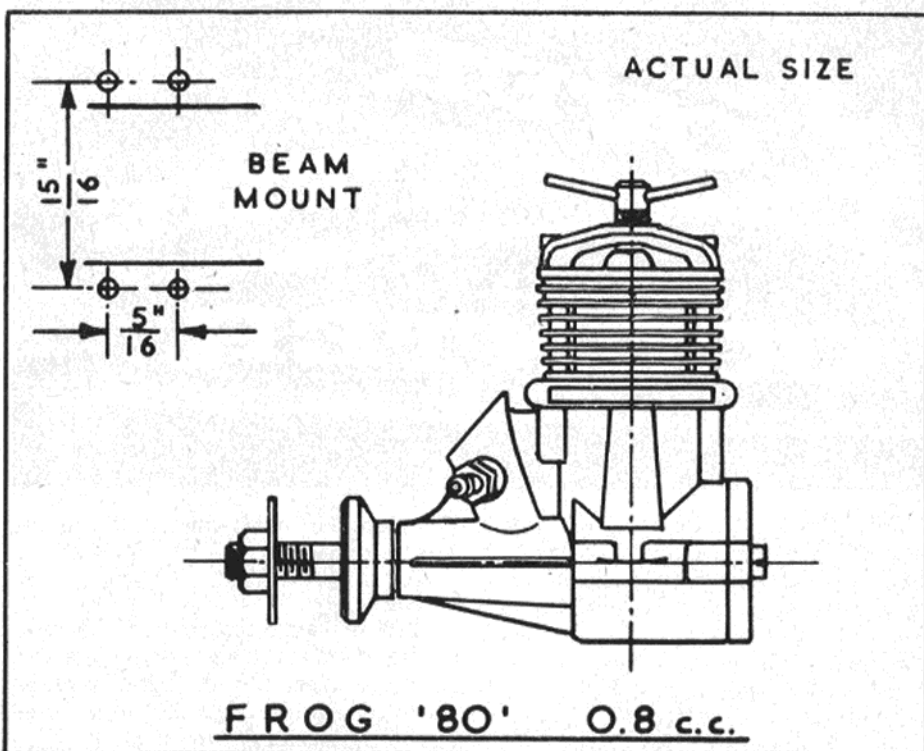

a minute or so, but re-starts are quick and with no need of priming through the ports. On small props, permitting speeds up to, and over, the peaking speed, starting is still good and we detected no tendency to "bite" when so loaded.

Unlike many diesels, the "80" is notably smooth running and, after running in, the engine was outstandingly good for the manner in which it held even readings. It was, for example, run continuously for ten minutes at 13,000 r.p.m. with vir-

tually no variation in speed. While no actual consumption tests were carried out, it was also apparent that the "80" is an unusually economical motor.

Torque tests were carried out at between 6,000 and 14,000 r.p.m. and the best torque recorded was at 8,500-9,000 r.p.m. where the equivalent b.m.e.p. was 49 lb./sq. in. Torque dropped off fairly evenly but more abruptly beyond 11,000-12,000 r.p.m. so that the peak of the power curve occurred at about 11,800 r.p.m. where the output was a trifle less than 0.064 b.h.p.

The Frog "80" is, of course, in the American Half-A piston displacement class, which will inevitably invite comparison with the popular 0.049 glowplug models in this group. In such a comparison, the Frog comes out well. As one would expect of a diesel, it is heavier than the average American 0.049, but delivers considerably high maximum torque. It is a slower revving engine than the glow Half-A's, but offers superior power up to its peak r.p.m. Obviously, the "80" will be best on slightly larger props than the usual Half-A sizes. The 6 x 4 can be regarded as the smallest practical size, the preference being for a 7 x 3 or 7 x 4 for most F/F applications.

Power/Weight Ratio (as tested) : 0.51 b.h.p./lb.

Specific Output (as tested) : 79 b.h.p./litre.

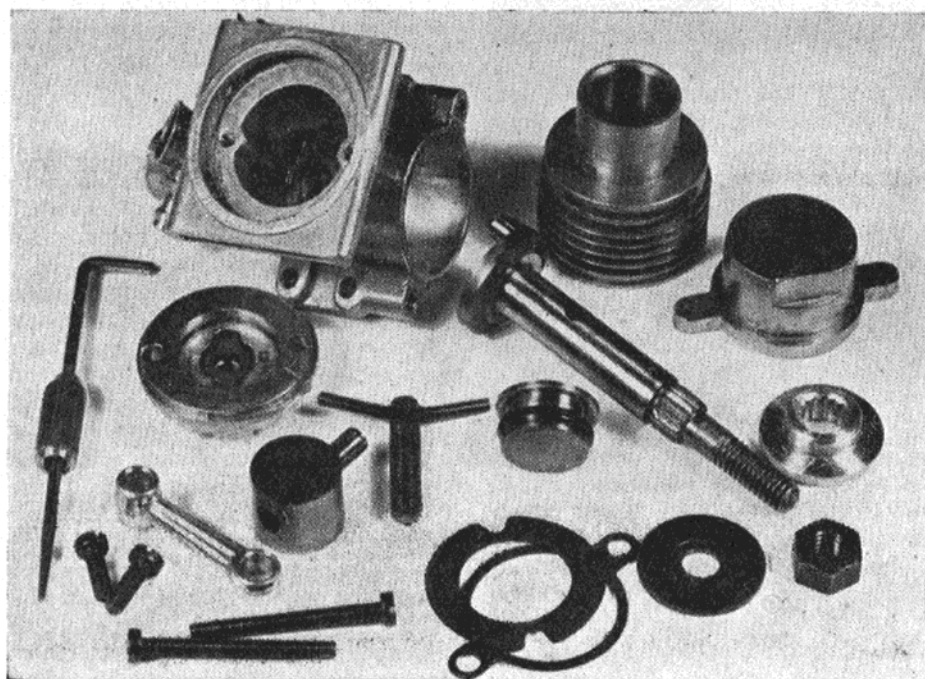

# OVER THE COUNTER

Two Keilkraft kits awaited with interest are the *Gemini*—a 22 in. span pre-fabricated, pre-decorated job similar to the *Nomad*, but rubber powered—and the 25 in. span *Tiger Moth* which is next in line in the "Star" series (following the *Seamew*.) Incidentally, how many people identified Keilkraft with those give-away balsa models included in each packet of a well-known brand of breakfast cereal? Keilkraft turned them out—something like four million of them!

\* \* \*

Mercury Model's *Mustang C/L* super-kit now includes a new transfer sheet, giant size and with fully authentic markings, fin decoration, etc. Next kit in this series is under way (the *Spitfire*), although it will not be in the shops for some weeks yet. We have seen the prototype made for flying trials, and it's a beauty.

\* \* \*

An almost toothpick quality is evident in the new Frog 7 × 4 and 6 × 6 propellers. They are available in either plastic or nylon and initial tests show that these should be among the most efficient plastic propellers yet produced. Prices are

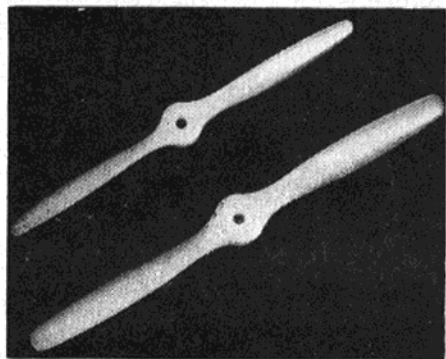

proportionate with the other propellers in the range.

\* \* \*

A new name that should become well-known, at least among contest fliers, is Tiger Props. We recently received samples of the four sizes currently available (8 × 3½, 8 × 4, 9 × 3 and 6 × 9) and they do indeed bear out the manufacturer's claim to be well designed and

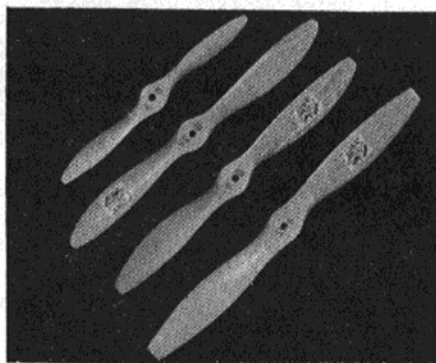

finished. The wood used is Yugoslavian beech and after initial machine carving each prop is hand sanded and receives two coats of varnish and one of fuel proofers. Other sizes will follow later this year, but it is emphasised that there is no intention of providing an extensive general range. The price is 2s. 8½d. each, except the 6 × 9, which is 2s. 6d.

\* \* \*

Few people beginning C/L flying with simple trainer models, wish to be bothered with wire lines, so to meet the need for a strong easily handled substitute, Keilkraft have marketed a terylene line. This is sold on cards of 100 ft. at 7½d. and is just the job, as the lines can be wound round the handle at the end of a flying session. One word of

warning though, terylene is quite "elastic" and some degree of over control is necessary to allow for this.

Also received from Keil's—a copy of their 1957 Handbook. This annual publication contains, in addition to a complete catalogue of their products, interesting articles on many aspects of modelling—price is 1s. 3d.

\* \* \*

Brighter colours and more attractive design are features of the new range



of Frog engine box labels. This applies to the "80," "149," "150" and Frog "500" packs.

\* \* \*

Hobbies Ltd.—the household word where fretwork is concerned—were rumoured some six months ago as showing an interest in the production of model aircraft kits. It now appears that they are definitely going ahead in this direction and plan to launch three models on the spring market—rubber, glider and power.

\* \* \*

Seems that International Model Aircraft may be a little late in producing a F/F kit to "match" their new Frog "80" motor. We hear it rumoured that the "80" developed rather more power than anticipated in designing the first prototype model, with the result that the performance was a little too "hot" for the less experienced modeller to handle. Our money is on a line of Frog flying scale kits coming out eventually around the "80." It seems just made for this application, particularly with inverted mounting. Incidentally, apologies to Frogs for quoting the price of the "80" as 42s. 6d. in last month's "Over the Counter." It is of course 45s.



# The Veron DEACON Reviewed

THE *Deacon* is a large (52 in. span) multi-purpose F/F power model. Obviously the manufacturer's aim is to put on the market a kit suitable for R/C or payload, but at the same time increase its scope (and sales demand) by making it equally suitable for ordinary F/F "sports" flying suitable for powering by any of the popular engines of from 1 c.c. capacity to 1.8 c.c.

The design follows a layout very much favoured by Phil Smith—a pylon depth fuselage with a cabin front, quite attractive in appearance but with the wing nice and high up for good stability under power. As a result, the *Deacon* should be a most docile model on 1 c.c. power, with its relatively light weight contributing a slow, floating glide.

Performance should be quite snappy on 1.5 c.c. and no doubt the experienced flier would be able to trim it out for typical "duration" climb on a hot 2.5 c.c. motor, if he wished. But with anything larger than about 1.5 c.c. power, engine weight would be likely to bring the c.g. forward of the design trim

position, calling for some considerable increase in downthrust angle.

Construction is quite straightforward and, being a large model, easy enough for even an inexperienced modeller to handle. The kit we examined was very clean and attractive in appearance, with good quality medium to medium-hard grade balsa throughout. All ribs are die-cut, with  $\frac{3}{16}$  in. sheet formers, fin parts, etc., printed on balsa. (In this country we have still not got around to die cutting sheet thicker than  $\frac{1}{8}$  in.) Wing tips are ready cut and—most gratifying—so are the ply dihedral braces and front formers. All materials are a

pleasure to work with. Our only suggestion for making up is that the  $\frac{3}{16}$  in. printed sheets are best cut out with a razor saw and fretsaw.

If the design does look familiar, well, the *Deacon* is a scaled up Veron *Cardinal*, and that model has made quite a name for itself as a really safe sports flier. With this heritage, the *Deacon* can hardly fail to be a success and introduce many hundreds of modellers to the additional satisfaction of "big" model flying. About the only point on which the kit slips up is that the  $1\frac{1}{2}$  in. wheels supplied are the size for its smaller brother. Two inch diameter wheels appear a necessity.



## Letters

Continued from page 71

have one of these things (5 c.c.) and if anyone cares for an exotic paperweight, I'll be glad to oblige. A beefed up Frog 500 is definitely a better idea, since merely increasing the displacement of the Miles will not change the excess weight, size and clumsiness, or lack of performance of the engine.

It's interesting to note that the only English engines that are in any demand where American, Japanese and other engines are available, are the definitely hot types like the Oliver and Amco. The baby diesels are fine for the kids, but for any serious flying they're just about useless.

I'm trying to get hold of an example each of a Yulon 30 and 49. If any of your readers can help me I'd be glad to reciprocate by helping them to obtain

The Editor does not hold himself responsible for the views expressed by correspondents. The names and addresses of the writers, not necessarily for publication, must in all cases accompany letters.

any American engines, or supplies or whatever they might want in return.

Yours faithfully,

BILL DAHLGREN.

A/2c Wm. Dahlgren,  
6910 Rad. Gp.,  
Sembach AFB.,  
Kaiserslautern, Germany.

### "I prefer diesel"

DEAR SIR,—I read with interest Mr. Miles's letter concerning the Miles Special 5 c.c. diesel.

I have had three Frog 500 glo-motors and found them satisfactory but very particular to fuel pipe position, etc., so last year I bought a Miles. When I took it out of the box it was very stiff due to being in the shop a long time, however, after priming through the venturi I turned it over a few times, held it in my hand and flicked, and to my surprise the engine burst into life.

The model I made for the Miles was a semi-scale machine of 56 in. span and 550 sq. in. wing area including flaps; the weight of the model is 36 oz. and I think this figure compares favourably with the large American stunt models which weigh up to 40 oz., although the Miles Special is 4 oz. heavier than a Fox 35. The performance of the Miles Special is excellent. It is easy to start and is not critical to fuel feed and will not misfire in the air. Using a 9 x 6 in. Frog nylon propeller, a speed of 65 m.p.h. is achieved.

An interesting point is that on a

9 x 6 in. the engine delivers peak power in the air, a thing that the glo-motors would not do.

In conclusion I should like to congratulate Mr. Miles on producing a first class engine which will overcome its high weight as its smaller brother the E.D. Racer did and also, Mr. Miles, my model does not look in the least like a traction engine.

Yours faithfully,

Burnt Green, K. S. BURTON.  
Nr. Birmingham.

A. B. SWANSTON wins this month's X-acto Knife Chest with his letter on '35' engines. Have you anything to say?—Choose your own subject, but keep it short, snappy and of general interest. "Flannelling" letters are NOT likely to win!

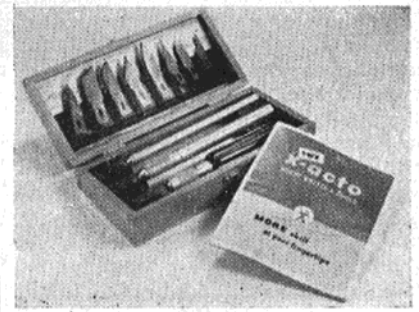

# Space Ships a' Coming

**T**ONY ROESTENBERG is a Dutchman, a solid, reliable type of man who settled in this country after World War II with his pretty Manx wife. They set up house at Vicarage Farm, which is close to Ranton village in Staffordshire. It is a small cottage, partly half-timbered, partly whitewashed brick, set in rather lonely surroundings at the end of a bumpy track across a field. Stafford itself lies three and a half miles to the east and there Mr. Roestenberg works as an assistant architect. The young couple have three children, two boys and a girl, and until the advent of that exciting day in October, 1954, they were indistinguishable from any other happy little family.

Little Karin, their two-year-old daughter, played happily in her own tiny, exciting world and waited until her two brothers arrived home from school to join in her games. At 4.15 in they came, six-year-old Ronald, and Anthony, a bright youngster of eight.

Half-an-hour went by. Suddenly there came from outside a tremendous hissing noise—a noise as if a huge kettle were pouring water upon a mighty fire. Rushing out of the house, they were astounded to see a large object moving very low overhead, going southwards.

"It's a jet!" cried one of the boys, and they all ran around to the other side of the house and looked in the direction that the object was going. There was nothing to be seen. Where had it gone? Bewildered, they looked up and their blood chilled when they realised why they could not see the object still moving across the sky. It was hovering over the house! Very low and completely silent, a queer round thing was standing in the air immediately over the little cottage. It was no jet—it was a vimana!\*

Brilliantly it shone in the sky, so low that they could make out every detail of its body. They could see that the upper part of the disc was revolving and the lower part stationary. Stationary above that aluminium-coloured disc was a dome, the back aluminium coloured but the front consisting of two transparent panels. With a catch in her breath, Jessie Roestenberg saw that looking through those transparent panels at her were two men. They had tipped the Saucer slightly forward so that they could see downwards the better, and from this angle they silently regarded her.



Ali

She recalls that they looked very like earthly men, with white skins and long hair down to their shoulders. Their foreheads seemed immensely high, with the features almost entirely in the bottom half of their faces. Their heads were enclosed in what appeared to be some sort of transparent helmets and they were dressed in clothes of turquoise blue that resembled ski suits that Mrs. Roestenberg had seen. But what appeared strangest of all to the little group of watchers on the ground was the unsmiling expression on the faces of the men from the sky. Sternly they gazed down at the Roestenberg family, not in an unkindly fashion, but almost sadly, compassionately.

The terror of that little group can be imagined. They had only vaguely heard of Flying Saucers (their father had read a magazine article on the subject a year earlier) and the two boys had not read a space comic for months. Their heads were in a whirl. Who were these peculiar visitors and where had they come from? They assumed immediately that they were not of this planet, and their fear, though momentary, was very great. The children flattened themselves on the ground, pressing themselves down against the cool, comforting earth, away from the menace that stared down at them from the skies. The dog, which had accompanied them into the garden at the first alarm, shot off howling down the track that led into the village. Yelping, he scudded along, impelled by the one thought of escaping from this strange thing that he could not understand, away to the comforting sights and smells of the humans that he knew and loved.

As Jessie Roestenberg watched, appalled, the vimana began to move, flashing a purply blue light from the front of it as it did so. At an angle of 45° it started to ascend, making no sound as it moved, but continuing the

flashing the whole time. With a gasp of relief Jessie ran into the house, intent on finding pencil and paper to sketch what she and the children had seen. As she looked for the stub of a pencil, the boys called out again from the garden. With fear returning once more to her heart she ran outside to see the Saucer coming back again, this time from north to south. It circled the house in an anti-clockwise direction one and a half times and then streaked skywards. It had gone at last. Mrs. Roestenberg had never seen anything go so fast. "It was going much faster than the fastest jet I have ever seen," she told me later.

At the time of the sighting it had begun to get dark and the vimana's trail—like that of a jet aircraft—showed like a shadowy pencil line against the blue of the sky. There was not a cloud in the heavens. Mrs. Roestenberg took one last look round and then ushered her children into the house to await the coming of her husband.

Mr. Roestenberg was absolutely astonished to hear his wife's story, but the way in which it was told, the obvious terror of his children, the absence of the dog, the pencil sketch that Jessie had made of the vimana, all convinced him that something very much out of the ordinary had happened in his absence and sent him hurrying to the police.

When they arrived they seem to have been very impressed by the story. One big constable rubbed hard at his head with his knuckles. "Well," he said, after a pause, "I never have believed in these here Flying Saucers, but I certainly do now."

\* Author's term for certain type of U.F.O.

## OTHER NEW BOOKS

We've said it before and we'll say it again, **The Observer's Book of Aircraft** (Frederick Warne & Co., price 5s.) is the best five bobs' worth of aircraft gen available. This new 1957 edition is similar in style to last year's annual, and is bang up to date with the

(Continued on page 105)

Condensed from the book "The Coming of the Space Ships" by Gavin Gibbons (13s. 6d.) by kind permission of the publishers Messrs. Neville Spearman & Co.



**ANGUS & DIST. AERO LEAGUE**  
New league comp. secretary is Roy Yule of Bucksburn A.T.

Six competition fixtures were planned. Venue of first is Montrose aerodrome on April 28th, for Open Rubber and a one-hour scramble, plus A/2 Glider. Between April and September, six A/2 competitions will be held in conjunction with the other events run by the league in 1957.

#### WEST OF SCOTLAND AREA

In the C.M.A. cup which was, after much confusion, made a decentralised event, B. Harris of Prestwick topped the area results, clubmate R. Sleight was second.

At the Area Team Race at Auchinharvie, Ardrossan swept the boards, coming first and second. Prestwick were rather dogged by hard luck, getting two models into the final only to come unstuck once they got there. Glasgow Barnstormers and Perth fared little better in A, although Perth as always swept the boards in B, R. Irvine, J. Dunn & Co., coming first and second, using their potent Barclay-tuned McCoy and Eta.

At the S.A.A. A.G.M., which was held in Glasgow, the major news item was the election of new comp. secretary, W. Ramsay, 8, Houston Street, Hamilton.

#### DORKING & DISTRICT M.A.C.

With next season in view, combat is still in the foreground of club activities. Quite a swing to team racing has taken place on the flying field recently, with "Eta 29" powered Mercury Thunderbirds appearing in the most striking colours of shocking pink.

A Seal of Merit has been awarded to the local model aircraft shop for their great help to our members. We believe this is the first club in this country to make such an award.

#### WHITEFIELD M.A.C.

The last contest of the season which the club attended was the Colne Winter Rally. Old Man Weather really gave us a selection that day with gales, rain, hail, snow and later on a flat calm developing into a fog. The club won five of the eight prizes, with J.O.D. winning both glider and rubber and L. Carley winning combat. H.O.D. and B. Eggleston came second in rubber and power respectively. Despite the variable weather the times were quite reasonable.

Christmas festivities for Whitefield consisted of a Christmas party held in a local social club, with girl friends invited. This was the first party of its kind to be held by the club for quite some years. The programme was a mixture of film shows, games and eating, plus a bar, and was enjoyed by all. It was agreed that we should make the party an annual event.

#### BRIGHTON & D.M.A.C.

The final results of the club championship showed Fred Boxall to be the winner, his brother Reg the runner-up, and Peter Brown third. Other results were:— Spence Nordic Shield, F. H. Boxall; Charles Cup (Open Power),

# CLUB NEWS

## AND NEWS FROM THE S.M.A.E.

A. Mussell; Mullett Rose Bowl (Open Duration), P. Brown; Brigden Cup (F.A.I. Power), I. C. Lucas; Vice-President's Trophy (Wakefields), R. J. Boxall; Lanes Cup (Precision Duration), R. J. Boxall.

1957 sees the club celebrating its silver jubilee and at the A.G.M. plans will be formulated to properly commemorate this event.

#### HYDE CHESHIRE M.A.C.

The above club is holding a R/C meeting on Sunday, April 7th, 1957, this being held one month later than the dates previously advertised.

Prizes are: 1st, 3 gns.; 2nd, 2 gns.; 3rd, 1 gn. Entry fee 3s. per model entered. Rules: model must be airborne not less than 5 and not more than 15 minutes. Points as follows: appearance and finish, 30; take-off, r.o.g., 30; H/L, 20; flying characteristics, 70; approach and landing, 30. Model at take-off point given 5 min. to become airborne. Other rules as per our 1956 rally. Entries in before March 28th, 1957.

Once again this coming season we offer the use of our very many acres of flying areas to persons, clubs and areas, just write and ask and you will be welcome.

#### WALLASEY M.A.C.

The club has been struggling manfully to run off the club comps. over the past month, i.e. between gales. Rubber and glider have both been flown, the former being won by John Hannay whilst Stan Hinds carried off the glider "pot." We held our power event but unfortunately "bad light stopped play" halfway through the event. Visibility at 3 p.m. being down to 30 yd. Although our points cup is not yet decided it seems certain to fall to either Hannay, Hinds or Done.

We hear that Waterbeach is to be the venue for 1957 Nats., we offer up our plea, please try

for Hemswell. After all, nobody could complain at the 'drome or the attendance, and now with petrol rationing, Hemswell, or should we say anywhere in Lincolnshire, would seem a more central venue.

As a result of the recent announcements made by the F.A.I., most members are now building "open" models. Interest is nicely divided between rubber, power and glider, although our winter evenings seem to concentrate more on cards than on building. We are hopeful of some new power models, however, as several new "hot" engines from the "Eiffelaender" stable have made their appearance. Last, but not means least, Mrs. Hannay has bought the wood for her new glider so it looks as if her threat of finishing it may materialise.

#### LONG EATON & D.M.A.C.

The club has organised an R.T.P. League which is now in full swing with the top speed reached at about 95 m.p.h. with an untuned unit. The club also has hope of its own workshop and headquarters within the near future.

#### WEST BROMWICH M.A.C.

So far this winter, the weather has been the main bogey for club activities, our combat and scramble comps. have both been postponed because of the bad weather. The F/F comp. was held in a gale, and 90 per cent. of the flight times were o.o.s., there were also a number of flights that were u/s (F/F power not being the club's best standpoint).

Now under construction by Mac Grimmet is a monster B.36 powered by six Olivers built from the Japanese kit. We are wondering how many bods it will take to fly the thing. Mac hasn't been so well lately so he has had plenty of time to puzzle that question out.

Some of the team racing fraternity in the club have been using the new Norman Long engine. Mr. Long asked us to build models as flying test-beds for the new engine, and we gladly obliged. The engines have been working very well and with new modifications should churn out the revs.

All that we can hope for at the start of the 1957 season is that we have just as good a one as the 1956 season was.

#### ENFIELD & D.M.A.C.

Two of our recent items have been a film show and a section in the local "Youth Festival" Exhibition. The film show was put on for us by the publicity department of the local Gas Board, a useful tip for other clubs to remember. The service is completely free, and they will show any films you wish, the only string being that they want to show one of their own for publicity (but this is usually one of the best ones anyway).

We usually find that displays tend to run along a definite trend all the time, so this year at the Youth Festival display we decided to try to be different. The result was a "model making machine" constructed of  $\frac{1}{2}$  square and wallpaper.

Dublin M.F.C. member Reg Orr shows off his E.D. 2.46 powered Junior 60. Model is really R/C but the only two flights to date have been strictly F/F only, due to battery trouble. Third time lucky we hope. Photo by G. Woodworth.

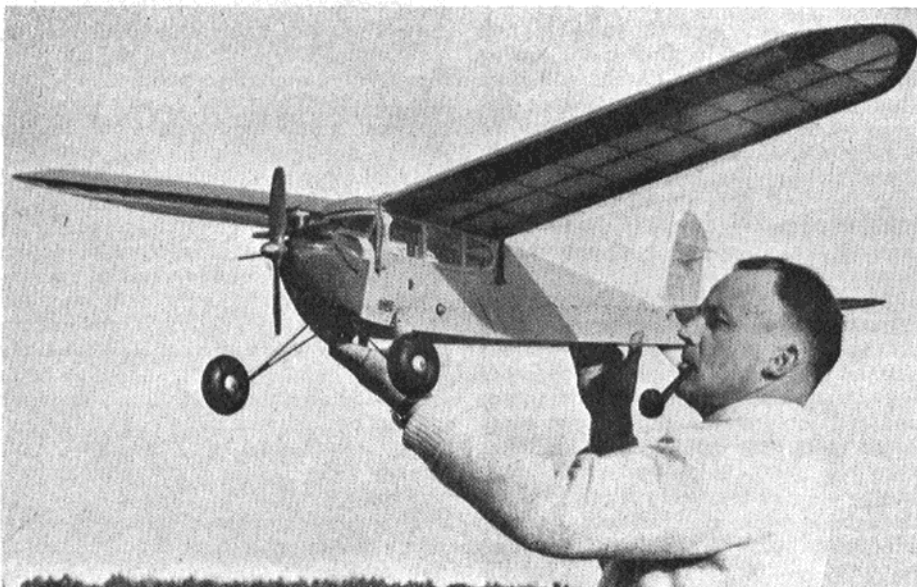

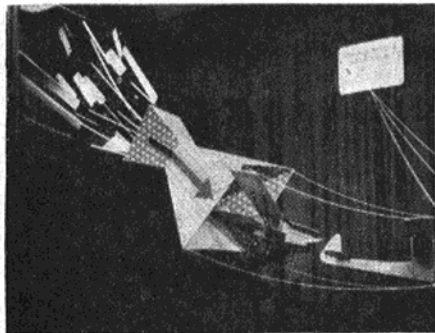

Enfield club arranged this novel "Model Making" display for a local exhibition. See their Club Report for full details.

The whole, with the materials being "fed" in and the models "flying" out was suspended by black thread against a black background, and the result was most effective. It was very simple to erect for the short opening time, and aroused much very favourable comment.

This year's Enfield C/L Rally will probably be on July 7th at the usual venue. It will include as before, T/R "A" and "B" Combat (basically to S.M.A.E. rules), Handicap Speed and maybe Stunt, although this is not definite yet.

#### CHEADLE & D.M.A.S.

We are running an A/I construction course followed by an A/I comp. and are also having a series of discussions on different types of models for the further education of all concerned. At the annual prize-giving, dinner and film-show, Junior Paul Gibson took Senior and Junior Power Cups as well as the all-round Junior Trophy.

#### SOUTHERN AREA

We are running an Area Rally in conjunction with the A/2, eliminators and the "team power" events to be held on March 31st, 1957.

Competitions include open power, glider and rubber, Class "A" and "B" team racing. There will be two prizes for radio models; one for the most interesting flight, the other for the best turned out model. There will also be a chuck glider event for all comers.

#### URMSTON & D.M.A.C.

The winter programme has started with the annual dinner which was a great success and was enjoyed by everyone. Combat has started to be

popular once more since R. E. Puddephatt, late of Foresters, joined the club.

Several interesting combat jobs have appeared but up to now have not been really able to show their paces. We will be sure of maximum strength on these since they are nylon covered.

#### NEW CLUBS

PECKHAM M.A.C. A. E. Fisher, 26, Strickland Court, S.E.15.

LAPWORTH & D.M.A.C. J. Miller, 2449, Stratford Road, Hockley Heath, Solihull, Warwickshire.

#### CHANGES OF SECRETARYSHIP

SOUTHERN AREA. J. H. Manville, 6, Bengal Road, Winton, Bournemouth.

LONG EATON & D.M.A.C. T. Watson, 4, Wood Avenue, Sandiacre, Notts.

TYNEMOUTH M.A.C. P. Jackson, 33, Mill Grove, Tynemouth.

PLYMOUTH M.F.C. A. H. Thomas, 38, Pemros Road, St. Budeaux, Plymouth.

CRYSTAL PALACE M.A.C. M. J. Ballentyne, 4, Kingsthorpe Road, Sydenham, London, S.E.26.

NORWICH M.A.C. R. J. Howard-Alpe, "Bracondale," Wymondham, Norfolk.

DORKING M.A.C. F. Tuck, 11, Parkway, Dorking, Surrey.

ABINGDON & D.M.F.C. A. J. Howe, 16, Mathews Way, Lamborough Hill, Nr. Abingdon, Berks.

HENDON A.T.C. M.A.C. M. Allan, 23, Haverford Way, Edgware, Middx.

Winner of the annual indoor contest held in Helsinki was Leiff Englund (left) seen here preparing his model with Pertti Koranin, with a best time of 8.06. J. Jaaskelainen, who took the picture, tells us that the contest is very popular, as the hall, which has a 56 ft. ceiling, is only available once a year and there are no alternative venues—shades of G.B.!

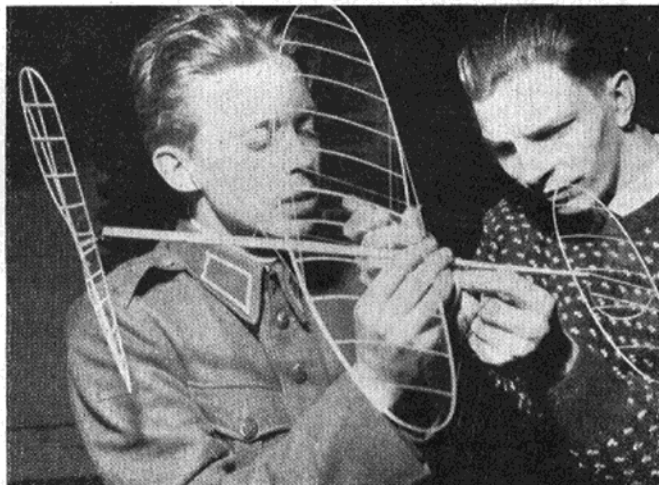

## TO ALL P.R.O.s

About this time of the year many clubs will have elected new press officers to take over the job of "spreading the news" of the clubs' activities, and at first the new man may not be sure of the best way of preparing a report for the Club News pages of MODEL AIRCRAFT.

The main thing to remember is that a report is published mainly to interest members of other clubs, who probably will not know personally the characters mentioned. Therefore "family" gags will be lost on the readers. Secondly, the ideal report from our point of view is one that can be sent straight to the printer with no alteration. A glance through the published reports will show the style we want, but here are the features of a good report:

1. About 150-200 words in length.
2. Typewritten, double-spaced, or clearly handwritten, preferably on every other line of ruled foolscap. This enables us to make alterations between the lines.
3. One side of the paper only and on reasonable size sheets—please, not on folded sheets of quarto notepaper!
4. Reports go to the printer on the 15th of the month before publication. If we receive them after that date they will have to wait until the next issue; if much earlier, they will not be topical.
5. Reports should be written specially for Club News—not sent as a personal letter to the Editor. There is no need to send a covering

## 1957 CONTEST GEN

In view of the present system of petrol rationing, and consequent restrictions on travel, the Council have decided to make certain amendments to the competition programme. Full details of the revised programme are contained in our Contest Calendar.

#### International and F.A.I. Events

There are no specification changes required for any F/F models used in F.A.I. events during 1957, the only rule change is that models may be hand launched, except in R/C events.

Since there are to be no International events in the Wakefield and Power classes, the Gutteridge and Astral Trophies, originally programmed as eliminators, will not be used as such. They will, however, remain as F.A.I. Formula events, and will rank for Pluggé Cup points. The S.M.A.E. Cup still remains as the A/2 eliminator, and

Areas will be required to hold one other eliminator in this class, during March, April or May. Areas will note that the time for this eliminator has been extended, so that they may fit it in at the Area meeting on May 19th, if they wish. The two F.A.I. events on that day will only be three flight (4-min. maximum) events. Note carefully, F.A.I. Formula, but only three flights.

Results of the S.M.A.E. Cup will be sent, as usual, to Londonderry House within seven days of the event; the results of the extra eliminator, together with the combined results and the names and addresses of the top 50 per cent., must reach the comp. sec. not later than May 31st, 1957. This is the latest, but in view of the heavy work likely in connection with the Nationals, earlier submission would be appreciated. Special forms will be issued to Areas for the

compilation of these combined results.

#### De-Centralised Contests

Pre-entry for these is still required, at least seven days before the event. "Late entries" will be accepted after this date, but at double fees. All results must now be submitted on the official result sheet, the generally used scraps of paper will no longer be accepted. The full names and addresses of the top three entries from each club must be given. Supplies of result sheets are readily available from Londonderry House, or the comp. sec. direct; a stamped addressed foolscap envelope would be appreciated.

#### Entry Fees

Please note there is no reduction in fee for junior entries in power contests; entry fee for this class is 1s. 6d. to all full members.



## AEROBODS OF NOTE



**E. W. "TED" EVANS**  
Ted is a master of the art of designing and flying 'Wakefields.' His models are supreme examples of craftsmanship

letter at all; just head the report with the name of the club and it will be obvious what it is. While we like to see club and area news-sheets, they are rarely suitable for reports and need a great deal of time spent on sorting out and rewriting.

6. Above all, we want news, not lists of contest results with their rows of flight times that mean little to anyone outside the club. And if nothing noteworthy has happened recently, it is a waste of time to write: "Bad weather has held up club flying this month but the boys are busy building and Joe Blank has nearly finished his 1953 Wakefield." This is not news, so give it a miss this month and wait until something interesting happens.

7. Finally, if you are electing a P.R.O., pick one who speaks English, and can spell too—remember "deisle" is spelt *diesel*. And not too much slang, please, or too many queer abbreviations.

Posing against an appropriate "Club" background is Cpl. N. Higgins with his Mach 1 powered Slick Stick, and the Model Aircraft Trophy it won for him in the R.A.F.M.A.A. Championships.



## New Books

Continued from page 102

latest types including the Soviet machines seen at Tushino last June.

A useful feature is the "N.A.T.O. Names for Soviet Aircraft," which contains brief notes on the various types and concludes with an explanation on Soviet designations.

Three quarters of a million visitors a year—that's the proud boast of London Airport, and reading **London Airport**—the official story of the new world air centre (H.M.S.O. 4s.), it is easy to see why this great air terminal eventually looks like rivaling the London Zoo in drawing-power. A browse through this book can make a "first visit" to the Airport an enjoyable experience by giving a hint of what keeps the wheels (or props) turning.

"One we wouldn't like to be without" is our verdict on **The World's Fighting Planes** by William Green & Gerald Pollinger (Macdonald & Co., 15s.). This is the latest edition of the title which was first reviewed in the January, 1955, issue of MODEL AIRCRAFT, and it contains "potted histories" of 283 aircraft. The notes are more comprehensive than those in the previous edition, the photographs are new, and the silhouettes first class. We are

particularly pleased to see that first flight dates and prototype serial numbers are included, and that performance data, while in many cases not official, at least give the reader a reliable estimate of each aircraft's potentialities.

From the same publishers (Macdonald & Co.) comes **Famous Fighters of the Second World War** by William Green (18s.). With interest in last war aircraft definitely on the increase, there is a constant demand for information on the subject; this beautifully produced book goes a long way towards providing accurate and detailed histories of the main fighters used by Great Britain, America, Germany and Japan.

Accompanying the authoritative text are photographs and line drawings showing each mark of the principle aircraft, while one mark of each aircraft type is illustrated by superb three-view "photographic drawings" of an individual machine. These scale drawings provide a first-class source of reference for the modeller, giving camouflage schemes, serial numbers, individual insignia, etc. In addition, the plan view is divided down the centre line and shows both upper and lower surfaces.

The types dealt with include the Bf.109, *Hurricane*, *Spitfire*, Bf.110, P-40, *Zero-Sen*, *Beaufighter*, Fw.190, *Lightning*, *Mosquito*, *Thunderbolt*, *Typhoon* and *Tempest*, *Kawasaki Hien*, *Kawanishi Shiden*, Me.262, *Messerschmitt Komet*.



## CONTEST CALENDAR

Mar. 17th	Garage Cup. U/R Rubber. D/C.	June 30th	<b>INTERNATIONAL TRIALS</b> —Centralised.
.. 31st	†S.M.A.E. CUP. A/2 Eliminator. †KEIL TROPHY. Team Power. Area.	July 7th	PILCHER CUP. U/R Glider. WOMEN'S CUP. U/R Rubber/ Glider. D/C. JETEX CUP. Jetex.
April 28th	†WESTON CUP. U/R Rubber. D/C. LADY SHELLEY CUP. Open Tailless. D/C.	.. 14th	<b>SCOTTISH GALA</b> —Centralised. CATON TROPHY. U/R Rubber. U/R Glider. U/R Power.
May 19th	†ASTRAL TROPHY. F.A.I. Power. †GUTTERIDGE TROPHY. Wakefield. Area.		TAPLIN TROPHY. R/C. TEAM RACING. "A" and "B" Classes. SPEED. All Classes.
June 9-10th	<b>THE BRITISH NATIONALS</b> —R.A.F. Waterbeach, Cambs *THURSTON CUP. U/R Glider. SHORT CUP. 2.5 c.c. Class PAA-Load. GOLD TROPHY. C/L Stunt.	Aug. 4th	<b>NORTHERN GALA</b> —Centralised. C.M.A. CUP. U/R Glider. FROG SENIOR CUP. U/R Power. FLIGHT CUP. U/R Rubber. RIPMAX SHIELD. R/C. PAN AMERICAN TROPHY. 1 c.c. Class PAA-Load. TEAM RACING. "A" and "B" Classes. SPEED. All Classes.
.. 9th	S.M.A.E. TROPHY. R/C. DAVIES TROPHY. Team Race "A." SPEED—All classes. International Eliminator. A/2 TAILLESS. International Eliminator. *SIR JOHN SHELLEY CUP. U/R Power. *MODEL AIRCRAFT TROPHY. U/R Rubber. INTERNATIONAL TAILLESS. New A/2 Specification.	Sept. 15th	HALFAX TROPHY. U/R Power. †MODEL ENGINEER CUP. Team Glider. Area.
.. 10th	SUPER SCALE TROPHY. Power Scale. AEROMODELLER TROPHY. R/C. DAVIES TROPHY. Team Race "B." SPEED—All Classes. International. Eliminator. COMBAT.	.. 29th	TEAM RACING. "A," "A" and "B" Classes. Area.
.. 23rd	Northern Heights Gala, Halton, Bucks.	Oct. 13th	K.M.A.A. CUP. U/R Glider. †FARROW SHIELD. Team Rubber. Area.
		.. 27th	HAMLEY TROPHY. U/R Power. FROG JUNIOR CUP. U/R Rubber/Glider. D/C.

†Plugge Cup events.  
\*Area Championship events.  
During March and April, Areas will be required to hold a second International Eliminator in the A/2 Class. Trials invites will be decided on the combined results.

# GAMAGES

## PLASTIC MODEL KITS

We are always first with any NEW PLASTIC MODELS that come on the market. We have a wonderful selection of all the latest Kits including Guns, Boats, Cars and Aircraft.



**HAWKER  
HUNTER 5/3**  
similar to illustration

### FROG 1/72 SCALE AIRCRAFT . . .

Sea Hawk, 5/3; Sabre, 5/3; Venom, 5/3; Hawker Hunter 5/3; Meteor, 5/11; S55 Helicopter, 5/9; Javelin, 7/6; Canberra, 8/6; Attacker, 5/3; D.H. 110, 8/6; Thunderjet, 5/9.

**LINDBERG AIRCRAFT . . .**  
Spitfire, 7/11; Mig 19, 7/11; Spirit of St. Louis, 9/11; Convair (V.T.O.), 12/-; Thunderceptor, 12/-.  
Post and pkg. on all Plastic Kits 10d. each; Two for 1/3.

### Just Arrived - - - The New LINDBERG SUPER SABRE

The first British model with movable controls and a replica of a real Jet Engine.

Hellcat 9/11 | Thunderbolt 9/11

# 13/11

### NEW REVELL KITS

Nautilus Submarine Kit ...	7/6	Ford Fairlane Sunliner Kit	9/6
1914 Regal Car Kit ...	6/11	Tally-Ho Coach Kit ...	7/6
1904 Oldsmobile Car Kit ...	4/11	Wells Fargo Kit ...	7/6

**GAMAGES 132-PAGE MODEL BOOK**  
The finest Model Book available on Model Aircraft, Boats, Trains, etc. **1/-** Post 4d.

**GAMAGES, HOLBORN, LONDON, E.C.1** HOL 8484

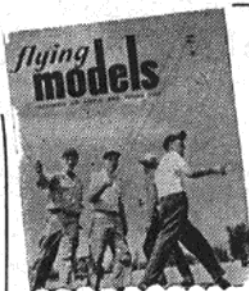

## How-to-do-it Magazine of U.S. Modeldom

Read FLYING MODELS, the only American magazine devoted exclusively to model aviation! Every issue includes how-to-build data on new model aeroplanes of various types (with full-size plans wherever possible) . . . worth-while hints . . . photographs . . . how-to-do-it information . . . and features for sport a-plenty!

**Now published every month.**

Annual subscription (12 copies) £1 9 6  
Including Postage

Mail your order and remittance today to:  
**ATLAS PUBLISHING & DISTRIBUTING CO., LTD.**  
(Dept. A)  
18 Bride Lane, Fleet Street, London, E.C.4

SPECIAL  
CHEAP  
EDITION

# Stunt Control Line Flying

By

## R. H. WARRING

The author deals comprehensively with the design of stunt models, covering wing and power loading, design, layout, component shapes and proportions, control systems, rigging angles and balance. Airframe construction is dealt with under specific headings, together with motors and stunt tanks. A special feature of this book is the 18 general arrangement drawings of outstanding stunt models by world experts, with over 100 line illustrations in all. There are eight appendix tables summarising design and constructional data of over 40 models.

The new edition is complete and unabridged. A considerable saving has been made by utilising a stiff board cover with square back in place of the normal cloth binding.

"Deals with each aspect in painstaking detail and gives innumerable examples and illustrations drawn from the best of modern British and American practice. The reviewer, like the author, having learnt stunt flying the hard way, can appreciate only too well the great value of this book, with its concentrated and tabulated information, to the newcomer who wants to do 'everything in the book.'"

JOURNAL OF THE ROYAL AERONAUTICAL SOCIETY

# 6s.

Postage 8d. U.S.A. and Canada \$1.50 post paid

From your model shop or

## PERCIVAL MARSHALL & Co Ltd

19-20, NOEL STREET, LONDON, W.1



**THE  
MASTER  
TOUCH**

... with Britfix colour dopes. Clean and bright, smooth and easy to work with, they provide the perfect finish which all good craftsmen expect! Available in a wide range of colours. ½ oz. jar, 8d.; 2 oz. jar, 1s. 6d.; ¼ pint tin, 2s. 10d.; ½ pint tin, 5s. Also in a new handy can, 1s.



**BRITFIX**

**PRODUCTS**

FREE, FULLY INFORMATIVE AND FULL COLOURED PRICE LISTED CATALOGUES ARE AVAILABLE TO RETAILERSON REQUEST



Products of the Humber Oil Co., Ltd., Marfleet, Hull

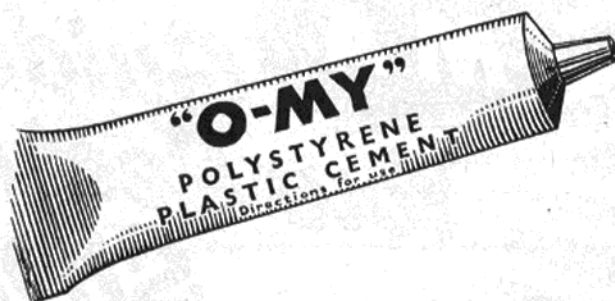

**"O-MY"**

**POLYSTYRENE**

**PLASTIC  
CEMENT**

6d a tube

**ALSO**



8d  
a  
Jar

A range of 25 colours, glossy and matt

**CELESTOR Manufacturing Co.**  
55, DARTMOUTH ROAD, LONDON, S.E.23  
Tel.: FORest Hill 2752

**MA**

# Guide to Your Best Model Shops

**Retailers**

ADVERTISE ON THESE  
PAGES TO REACH THE  
LIVE MODELLERS IN  
YOUR TOWN

**Readers**

YOU CAN DEAL WITH  
THESE MODEL SHOPS  
WITH COMPLETE  
CONFIDENCE

**BIRMINGHAM****Hobbies Ltd.**

100a, DALE END, BIRMINGHAM 4

A branch of the firm which is known to Modellers throughout the world. All M.A. requirements stocked

**BRISTOL****The Model Airport**

51, COLSTON STREET

Get your supplies from the leading M.A. shop in the town

**BIRMINGHAM**

Tel.: Midland 0972

**Hornton's**

32, STEPHENSON STREET, BIRMINGHAM, 2  
(Facing stage door Theatre Royal) and  
1, NAVIGATION STREET, BIRMINGHAM, 2  
(Adjoining Queens Hotel)  
Stockists of Model Aircraft, Railways and Ships

**CARDIFF**

Tel.: 29065

**Bud Morgan**

THE MODEL AIRCRAFT SPECIALIST  
22/22a, CASTLE ARCADE

SEND 4d IN STAMPS FOR MY 1956 PRICE-LIST

**BIRMINGHAM****Model Aerodrome Ltd.**

43, TEMPLE ROW Central 1223  
141, STRATFORD ROAD Victoria 0824  
Ships, Railways, Aircraft, etc.

**CHATHAM****Le-Core Bros.**

For all your model requirements  
373, HIGH STREET, CHATHAM  
and 264, HIGH STREET, ROCHESTER

**BIRMINGHAM**

Tel.: Northern 5569

**The Model Mecca**

204-206, WITTON ROAD, 6  
A 100% Modelling Shop. Aircraft Kits, etc.  
Trix "OO" L.M.S. Co. "O" gauge 5 and 5a buses pass door  
WRITE, PHONE or CALL

**DARTFORD****Modern Models**

49-51, LOWFIELD STREET, DARTFORD, KENT  
Whether you call or whether you post, we claim we've got more stock  
than most

**BRIGHTON**

Tel.: Brighton 26790

**Model Aerodrome Ltd.**

37, WEST STREET  
Ships, Railways, Aircraft, etc.

**EVERYWHERE**

Tel.: Gerrard 8811

**Model Aircraft**

19-20, NOEL STREET, LONDON. W.1  
This advertising space is available to all good retail  
Model Shops. Rates may be had on application



**GLASGOW**

Tel.: Central 5630

*Caledonia Model Co.*

5, PITT STREET, C.2

THE engine repair specialists. EVERYTHING for the enthusiast, with personal attention from GEORGE LEASK, A.M.I.B.E.

**LONDON**

Tel.: Gulliver 1588

*Martin's Model Shop*

65, FORTRESS ROAD, KENTISH TOWN, N.W.5

Keilkraft and other makes of Model Aircraft. Boat Kits. Full accessories. Tri-ang Railways. Personal service by E. C. Martin

**GLASGOW**

Tel: Central 5042

*Hobbies Ltd.*

326, ARGYLE STREET

A branch of the firm which is known to Modellers throughout the world. All M.A. requirements stocked

**LONDON**

Tel: Hop 3482

*Model Aircraft Supplies Ltd.*

171, NEW KENT ROAD, S.E.1

The oldest established model aircraft shop in London. Personal service with satisfaction

**HOUNSLOW**

Tel.: Hounslow 0041

*Poulton's Model Shop*

79, HIGH STREET  
HOUNSLOW, MIDDX.

Model aircraft, boats and trains. No charge for technical advice, engine runs or radio checks

**LONDON**

Tel.: North 4272

*Henry J. Nicholls Ltd*

308, HOLLOWAY ROAD, N.7

M.A. enthusiasts' complete stockist. Britain's No. 1 Model Shop. H.J.N. will be pleased to see you

**IPSWICH**

Tel: 51159

*East Anglian Model Supplies*

37, UPPER ORWELL STREET, IPSWICH

Wakefield gears: 3s. each, post 2½d. Contest "Avenger" sailplane Nordic A/2 design. Plans and cut ribs 10s. Kit, 23s. 6d., both post free

**LONDON**

Tel.: GULLiver 1818

*Ripmax Limited*

39, PARKWAY, CAMDEN TOWN, N.W.1  
**THE RADIO CONTROL SPECIALISTS**

All Requirements stocked PLUS Personal Mail Order Service

**LIVERPOOL**

*Precision Model Engineering Co. Ltd.*

53, WHITECHAPEL, LIVERPOOL, 1

Liverpool's premier rendezvous for all modellers. The shop where experienced modellers offer you the benefit of their experience. North of England's leading MAIL ORDER HOUSE

**MANCHESTER**

Tel.: Blackfriars 3972

*The Model Shop*

13, BOOTLE STREET, DEANS GATE

We have **EVERYTHING** in stock for the aeromodeller: Kits, Engines and Accessories

**LONDON**

Tel.: London Wall 437

*Hobbies Ltd.*

87, OLD BROAD STREET, E.C.2

A branch of the firm which is known to Modellers throughout the world. All M.A. requirements stocked

**MANCHESTER**

Tel: Central 1787

*Hobbies Ltd.*

10 PICCADILLY

A branch of the firm which is known to Modellers throughout the world. All M.A. requirements stocked

**LONDON**

Tel.: Chiswick 0858

*Jones Bros. of Chiswick*

56, TURNHAM GREEN TERRACE, W.4

1 min. Turnham Green Station (Dist. Line)

THE SHOP WITH THE STOCK  
OPEN SATURDAYS 9 a.m.-6.30 p.m.

**NEW ZEALAND**

Tel.: 2305 (all depts.)

THE *'Betta' Model Aeroplane Supply Co.*

P.O. BOX 260, NEW PLYMOUTH

N.Z.'s largest model supply house with 100% coverage of New Zealand. Our 200-page catalogue for 2s. 6d. is posted anywhere

**PADDINGTON**

Tel.: 8827-8-9

THE COMPLETE MODEL SHOP

*Burleigh's*

303, EDGWARE ROAD, W.2

All your wants supplied by return  
BURLEIGH, OF EDGWARE ROAD, LTD.

**SOUTH AFRICA**

*The Hobby Centre*

The Modellers' Mecca

133, COMMISSIONER STREET, JOHANNESBURG

Large stockists of British, American and European supplies.  
Sole distributors Super-Tigre and Taifun engines

**SOUTH AFRICA**

*A. W. Yardley (Pty) Ltd.*

31, KERK STREET, JOHANNESBURG

Model plane, model ship and model railway supplies from the leading  
British and American factories

**SUTTON**

Tel.: Vigilant 8292

*E. L. S. Model Supplies*

272, HIGH STREET, SUTTON, SURREY

Surrey's Hobby Centre. By return Postal Service

Complete stock of all M.A. requirements

**CLASSIFIED ADVERTISEMENTS**

SEND FOR LIST of over 60 Plastic Construction kits—planes,  
cars, boats, 2s. to 25s., from—Box No. 100, MODEL AIRCRAFT Offices,  
19-20, Noel Street, London, W.1.

**E.C.C. REPAIR SERVICE**

SERVICE AND REPAIRS PROMPTLY CARRIED OUT  
ON ALL E.C.C. RADIO EQUIPMENT  
ALL WORK GUARANTEED

**G. G. DAVIE**

7, Davidson Road, Thorpe, Norwich, Norfolk  
Phone: Norwich 33528

*The Balsa Wood Company Ltd.*



**AFRICA HOUSE  
KINGSWAY  
LONDON W.C.2.**

Telephone · HOLBORN 7053  
Telegrams · BALSAWUD LONDON

**\*WE IMPORT ONLY THE VERY  
FINEST SELECTED Balsa  
WOOD FOR THE MODEL  
MANUFACTURING TRADE**



**LA CARTA  
MODELSPAN,**

preferita dagli  
aeromodellisti esperti,  
é la più richiesta e la  
più usata in Italia

**MODELSPAN  
TISSUE,**

preferred by all expert  
aeromodellers, is the most  
extensively used covering  
tissue in Italy and the most  
in demand

**M<sup>RE</sup> FR. ZIFFER SOLARIA,  
MILAN**

**THE NEW SUPER  
MODELSPAN COVERING TISSUE**

**TRIX  
x-acto**

... for easier filing, planing,  
cutting and glueing.

**DUAL PURPOSE  
CLAMP & VICE SET**

Trust Trix to think of such a handy addition to your equipment. Four different sized clamps for modelling and handicrafts which, when used in pairs, form two adjustable vices that have scores of uses where the usual type of vice would be too clumsy.

X-acto Clamps are made of special aluminium alloy, with a tensile strength of 18 tons p.s.i., and only a third of the weight of steel. With Cadmium-plated steel screws & swivelling lock plates

Set of four different sizes — 10/6d.

TRIX LTD. 11 Old Burlington Street, London, W.1.

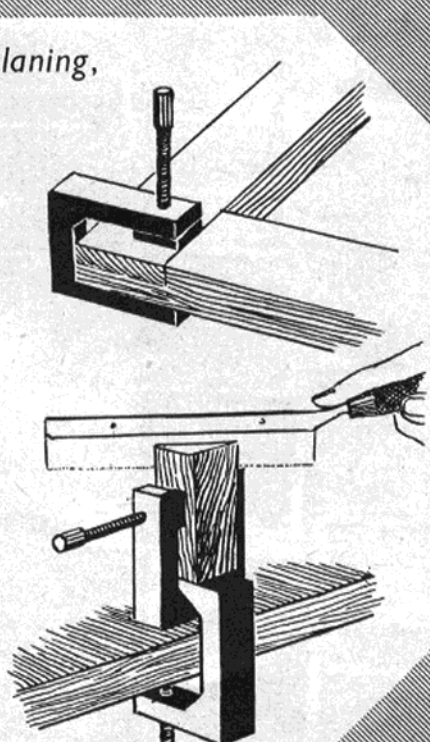
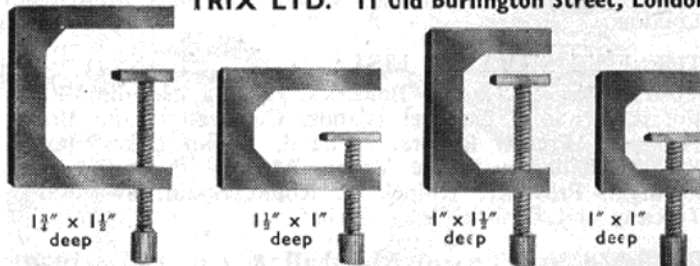



**NEW**

**2" DIA**

**M.S. AIRTRAP**

- AVAILABLE WITH 10, 12 & 14 GAUGE BUSHES. State size required.
  - HUBS 'LOCKED ON' TO TYRES.
  - PLASTIC HUBS, DURAL BUSHES.
  - FOR CONTROL LINE OR FREE FLIGHT.
  - TO RE-INFLATE—JUST SLACKEN HUBS THEN TIGHTEN UP.
- TRY 'M.S.' WHEEL CLIPS

**7/9**  
POST & PACKING  
6d. EXTRA

Trade enquiries invited

**THE MODEL SHOP**

(NEWCASTLE UPON TYNE) LTD.  
18 BLENHEIM STREET. Tel: 22016.  
NEWCASTLE UPON TYNE ENGLAND.

**DEALERS !!**

Is this stunning kit ?  
on your shelves ?

The model that gets a  
rave review wherever  
it appears — see last  
month's Model Aircraft

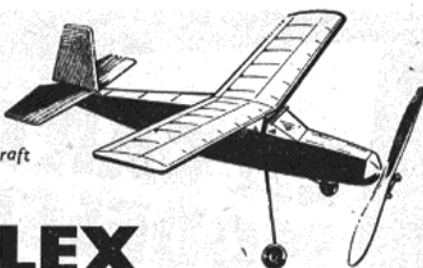

it's  
**SIMPLEX**

Everybody's building it—for indoor R.T.P.—for Club "one-model" contests—or as the most perfect beginner's kit. Includes specially carved prop, Dunlop rubber, Britfix cement, Equado balsa, Modelspan tissue, ready-made ribs, tail, fin, bushed noseblock, propshaft, undercarriage, and a guarantee that it will fly better than any other 20-incher. Send direct, or buy through your local model shop. 7/6

**SIMPLEX MODELS, HIGH ROAD, CHIGWELL, ESSEX**

**T r u c u t**

**PRECISION AIRSCREWS**



**Planning Your Summer Holiday ?**

**F**ORTNIGHT HOLIDAY GUIDE BOOKS will help. You will want to weigh up the merits of different holiday centres before making arrangements and reserving accommodation. These guidebooks give you up-to-date and completely impartial information about the places concerned. There are 36 titles. New books just published are: Bavaria, Holland, Portugal and Provence. The Continental titles advise you on climate, local customs, living standards, types of hotel accommodation and prices, and give useful help as to preparations for your visit, essentials to take, etc. Each title is in handy pocket or handbag size and is illustrated with photo plates.

**THE THREE AND SIX LIST :**

Devon, East Coast, Firth of Clyde, The Grand Tour, North Wales, Wye Valley, Yorkshire Coast, Not Sixty Miles from London.

**THE FIVE SHILLING LIST :**

Austria, Bay of Naples, Balearics, Bavaria, Belgium, Black Forest, Brittany, Channel Islands, Cornwall, Costa Brava, Denmark, French Riviera, Holland, Italian Lakes, Italian Riviera, Killarney, Loire Valley, Madeira, Norway, Paris, Portugal, Provence, Rhineland, Rome, Spain, Switzerland, Tuscany and Umbria, Yugoslavia.

Published by Percival Marshall & Co. Ltd., 19-20, Noel Street, W.1. If you order direct, please add 3d. per copy for postage.





# E.D. Diesels...

Every one of this .46 to 5 c.c. range is individually tested for accuracy and reliability up to a standard that ensures the greatest possible speed and performance.

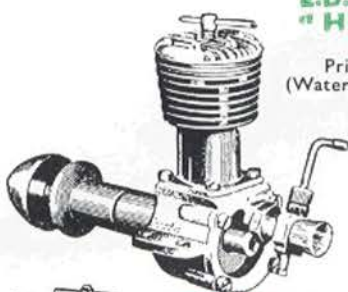

**E.D. 3.46 c.c.  
"HUNTER"**

Price £40.11  
(Water cooled model  
£56.1)



**E.D. 2.46 c.c.  
"RACER"**

Price £40.11  
(Water cooled model £57.1)



**E.D. 0.46 c.c.  
"BABY"**

Price £2.18.4

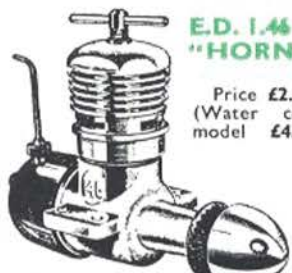

**E.D. 1.46 c.c.  
"HORNET"**

Price £2.8.4  
(Water cooled  
model £40.11)

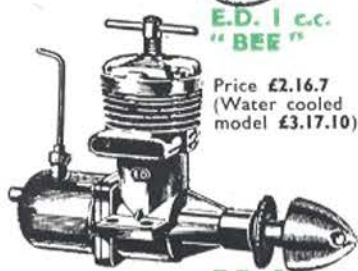

**E.D. 1 c.c.  
"BEE"**

Price £2.16.7  
(Water cooled  
model £3.17.10)



**E.D. 5 c.c.  
"MILES  
SPECIAL"**

Price £8.10.4  
(Water cooled model  
£10.4.4)

**A VETERAN  
OF THE E.D. RANGE**  
*"still going strong"*



**2 c.c.**  
**"Competition  
Special"**

Introduced in 1947 and has proved an ideal engine for control line, stunt and speed competitions.

Made British Speed Record 1950 for Control-Line Flight, 89.95 m.p.h.

Gives 23 oz. static thrust and incorporates vernier compression adjustment.

Bore .5 in. Stroke .625 in. Max. B.H.P. 11 at 7,300 r.p.m. Height 3 in. Length 4 in. Width 1 7/8 in. Price £3 3s. 11d.

The general longevity of E.D. models speaks for the foresight and skill of their designers and their efforts have been amply rewarded by the outstanding success of models fitted with E.D. Engines.

They are now recognised all over the world as the finest, most reliable and efficient performers available.

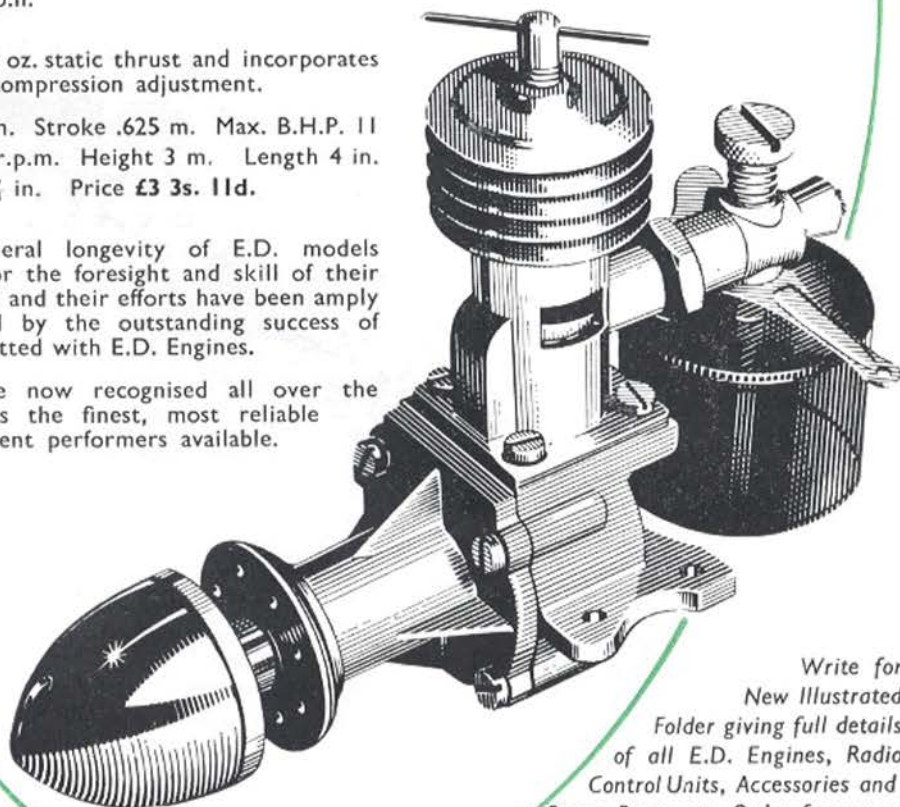

Write for  
New Illustrated  
Folder giving full details  
of all E.D. Engines, Radio  
Control Units, Accessories and  
Spare Parts, etc. Order from your  
Model Shop.

**E.D. ELECTRONIC DEVELOPMENTS (SURREY) LTD**  
DEVELOPMENT ENGINEERS  
PHONE MOLESEY 6037-6038 ISLAND FARM RD. WEST MOLESEY, (SURREY) ENGLAND. GRAMS "EED" EAST MOLESEY



## THE "AEROBAT" 689 KP

Extremely manoeuvrable, and fitted with the Frog "249" will prove formidable in any contest. Kit includes rubber wheels, moulded spinner and canopy. Undercarriage and wood parts ready shaped. Span 38".

PRICE 25s.

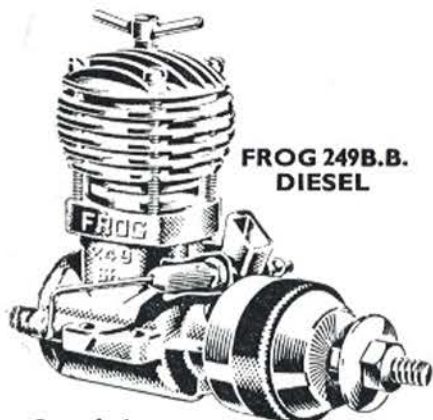

FROG 249B.B.  
DIESEL

One of the new range of Frog Motors. Fitted with twin ball-races and angled throttle lever, it is among the leading motors of its class. Price: 79s. 3d.

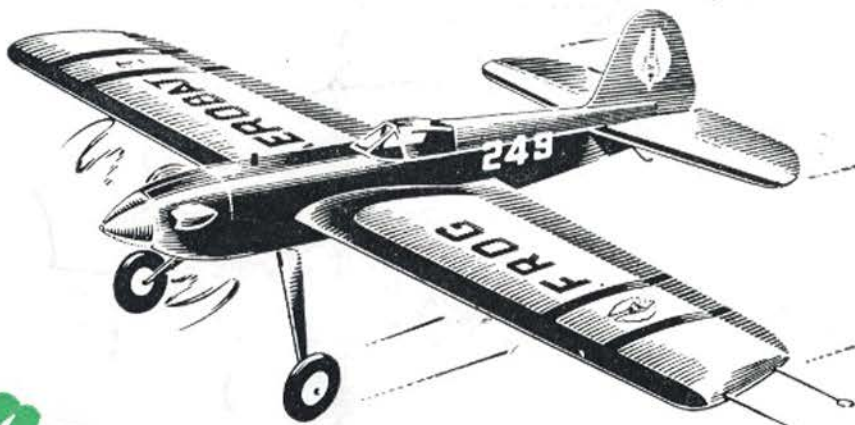

*Fly a*

# FROG



## SENIOR SCALE MODELS

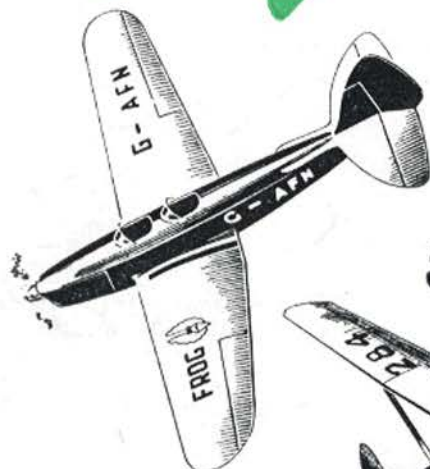

B.H. MOTH MINOR.  
730FK.

A popular pre-war light aircraft. 22" span. Rubber driven. Price: 5s.



CESSNA  
BIRD DOG. 731FK.  
An attractive model of this famous Army Spotter plane. 22" span. Price: 5s.



SHORT SEAMEW 732FK.  
A model of the latest Service aircraft; kit includes moulded cockpit canopy. 22" span. Price: 5s.

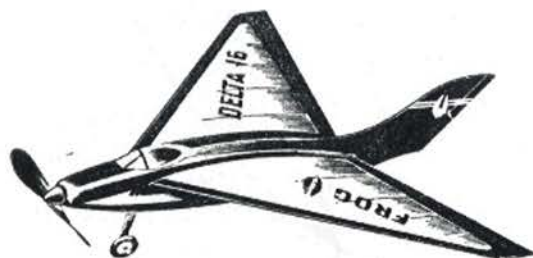

DELTA 16 640FK  
A new model of a delta-wing design, 16" span. Rubber driven with moulded air-screw, wheels and canopy. Price: 5s. 6d.

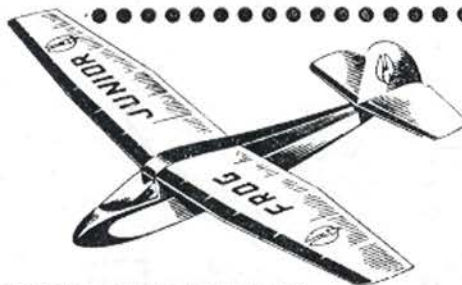

JUNIOR SAILPLANE 720GK.  
A new simple-to-build model, and a fine flyer. 20" span. Price: 3s.

Products of the Lines Bros. Group

INTERNATIONAL MODEL AIRCRAFT LTD. • MERTON • LONDON • S.W.19