

**RADIO CONTROL**

# **MODELER**

THE LEADING MAGAZINE FOR RADIO CONTROL • JUNE 1966 50¢



**PFIFF: The Magic Biplane**  
By John Garde

---

**TOLEDO: 1966**

---

**3 + 1 DIGITRIO**  
By Ed Thompson

---

**Easy Twin**  
By Walt Watkins

**THE DEB-N-AIR: COMPETITION MULTI BY BRYAN LAKIN**

# MODELER

JUNE 1966

VOL. 3 NO. 6

Editor • Don Dewey  
 Production Editor • Chuck Waas  
 Technical Editor • Ed Thompson  
 Art Editor • Bob Dance  
 Technical Art Editor • Dick Kidd  
 Contributing Editors •  
 Ken Willard  
 Jerry Kleinburg

Bernie Murphy  
 Chuck Cunningham  
 Mert Mischnick  
 Foreign Editor • Cliff Rausin  
 Editorial Assistants •  
 Sally Dewey  
 Kathleen Acton  
 Administration • Joy Kirby



16



26

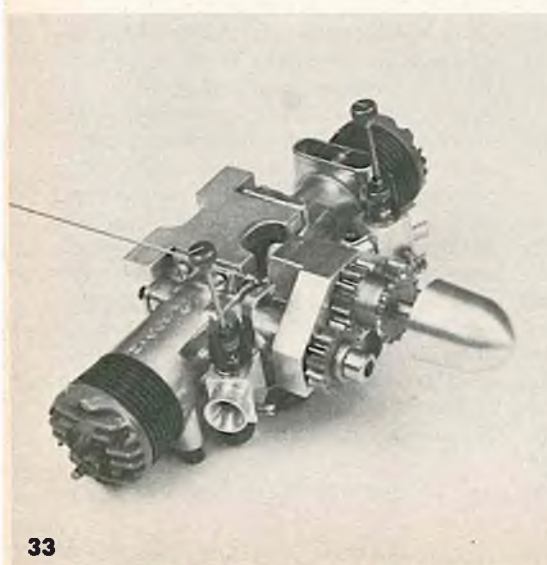

33

## FEATURES

Pfiff	16	John Garde
Toledo 1966	23	Bernie Murphy/Chuck Waas
Deb-N-Air	26	Bryan Lakin
Easy Twin	33	Walt Watkins
Phelps Pulser	35	Stanley J. Brown
R/C Flying Safety	37	Cdr. Lou Guerrieri, USN
Low Wing Tauri	39	George Lowder
Digitrio Tips	40	Frank Baker
3 + 1 Digitrio	41	Ed Thompson
Fillets	45	Capt. John D. Woods, USAF

## DEPARTMENTS

Editor's Memo	6	Don Dewey
Showcase '66	7	RCM Staff
Cunningham on R/C	10	Chuck Cunningham
Top Out	12	Jerry Kleinburg
Sunday Flier	14	Ken Willard
Regatta	48	RCM Staff
RCM Interview	51	RCM Staff
The Roostertail	55	IMPBA Staff

## COVER

A magnificent 78" modified Great Lakes Trainer, built from a Vic's Custom Kit. The other lovely model was also provided through the courtesy of Vic's Custom Kits. Note full size bipe in background.



R/C MODELER CORPORATION, Publisher  
 Editorial and Advertising Office  
 P. O. Box 487  
 Sierra Madre, California 91026  
 Phone (213) 356-1066  
 Phone (714) 494-0768

Business and Circulation Office  
 P. O. Box 1128  
 Laguna Beach, California 92652  
 Phone (714) 494-0768  
 Official Publication of  
 The National Association of Radio Control Clubs  
 International Model Power Boat Association  
 National Miniature Pylon Racing Association

Subscription service: All subscription correspondence should be addressed to R/C Modeler Circulation Dept., P. O. Box 1128, Laguna Beach, California. Please allow at least six weeks for change of address. Include your old address, as well as new — enclosing an address label from a recent issue wherever possible.

Editorial contributions: must be accompanied by return postage and will be handled with all reasonable care. Publisher assumes no responsibility for return or safety of art work, photographs, or manuscripts. Address editorial contributions to The Editor, R/C Modeler Magazine, P. O. Box 487, Sierra Madre, California.

Subscription rate: One year, \$5.00, 2 years \$10.00, Canada, on year \$6.00. All other countries, one year \$6.50. Payment from all countries must be in U. S. funds.

R/C MODELER MAGAZINE is published monthly by the R/C Modeler Corporation. Contents copyright 1966. All rights reserved. Printed in U.S.A. Second Class Postage paid at Milwaukee, Wisconsin and at additional mailing offices.

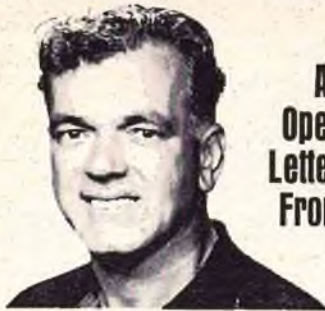

An  
Open  
Letter  
From

## ED KAZMIRSKI to JACK HENRY OF VECO

"Dear Jack"

"Your new Veco 61RC is no doubt the best engine I have ever owned. It pulls my 9½ lb. 8 ft. span ship around like no other engine has.

"On a big heavy ship like this all other engines run hot. This is because on a big ship the engine is always working hard because of the drag and is always loaded.

"I have now run nine gallons of fuel through the engine, and it looks like it just came out of the box. It does not have a bit of varnish inside or outside. The fuel draw is great. With the nose up it still pulls like mad. It looks like the 61 will last longer than your 45, and I never wore mine out."

Sincerely,

*Edward Kazmirski*

### VECO RC 61



#### SPECIFICATIONS:

Bore	.940	Stroke	.880
Weight	14 oz.		
Power	12,000 rpm/Top Flight		
	11-8 wood prop		

Fuel Consumption approximately ¼ ounce per minute. Break in 15 to 30 minutes.

**VECO 61 LIFETIME GUARANTEE:** Any part that fails because of workmanship or material will be replaced free-of-charge during the useful life of the engine, excluding normal wear or damage due to external causes. GP-61RC/\$55.95.

Ask for Veco Products at your hobby dealer • kits • accessories • fuel • tanks • hardware  
Send 10¢ to Dept. R for 1966 catalog:  
Box 229, Burbank, California



**VECO PRODUCTS CORP.**  
a subsidiary of Henry Engineering Company

# EDITOR'S MEMO

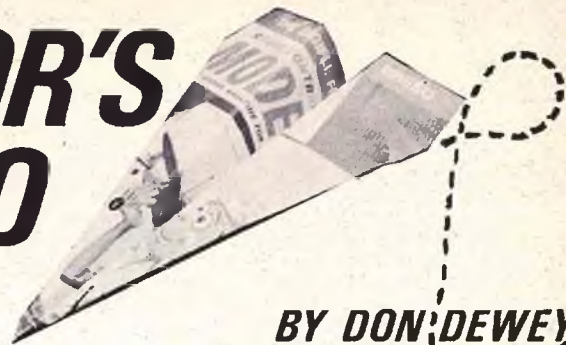

BY DON DEWEY

**T**HE rose-scented press release, issued March 4 by AMA's George Wells, did little to cover up the aroma of fish that has been emanating from the AMA's Washington headquarters during the past few weeks.

We are referring, of course, to the announcement by the Academy of Model Aeronautics, of the suspension of publication of the Academy magazine, 'Model Aviation,' and the affiliation of the AMA with the newly purchased 'American Modeler' magazine.

On the surface, the AMA press release indicates that all is well — that the Academy leadership has once again acted in the interests of its membership by arranging with Potomac Aviation Publications, Inc., the firm that purchased American Modeler from Conde Nast Publications, to incorporate a distinct section within that publication for all AMA news and material which normally appeared in 'Model Aviation' magazine. Each AMA member, by virtue of his membership, would obtain a copy of American Modeler (which will be a monthly as of January 1967) at no charge, replacing the former 'Model Aviation.'

The purpose behind this move was, on the surface at least, intended to bring the Academy to the attention of more modelers — potential AMA members that the Academy could not reach without newsstand and hobby shop distribution of their publication. The AMA, in turn, according to their press release, would "pay the publisher for the cost of printing copies for AMA members. This cost is to be within that now budgeted for the Academy's former publication, 'Model Aviation.'"

What the Academy's press release did not state were **all** of the facts. We think that you should know the rest:

Potomac Publishing Company is, in effect, one Edward C. Sweeney, President of the National Aeronautics Association, with which the Academy of Model Aeronautics is affiliated. Mr. Sweeney is well known for his activities in the NAA and general aviation. He is also a long-standing friend of the AMA Executive Director, John Worth. Mr. Sweeney purchased American Modeler Magazine from the Conde Nast Pub-

lishing Company.

The arrangement between the Academy of Model Aeronautics and American Modeler Magazine was announced to the model press at the recent Toledo Conference and was the **first indication** to the assembled members of the press or to the Academy general membership that these transactions **were even being considered!**

The fact that one of the three general model aviation magazines, Model Airplane News, Flying Models, and American Modeler, was arbitrarily selected by the AMA and would be the official publication of the Academy, mailed to all members, forced the other publications into a position that would be somewhat similar to a case whereby the Federal government might arbitrarily select one newspaper, or one television network, as its official news media! Such an inequitable arrangement between a governmental organization and one private enterprise forces other competitive enterprises in the same field to actively aid its own competition if they continue to support their own government! The ramifications of such an arrangement would stagger the imagination! And it wouldn't be very long before it would be heard in the Supreme Court.

Immediately following the announcement in Toledo, we contacted several members of the Executive Council and discovered that they had not even officially voted on this proposition as yet. By the time of the press release on March 4th, however, the ballots were unanimous from the Council — a Council who **supposedly** represents the wishes of the AMA members in their district, but who, **by their own admission**, were attempting to keep the entire transaction **confidential** from the general membership until those negotiations were completed. This attempt to conceal the whole story from the general membership was confirmed by this writer in a telephone conversation with John Worth, AMA Executive Director, on March 4th, at which time Mr. Worth stated to the effect that this was done to protect the sale and purchase of

(Continued on Page 85)

# CUNNINGHAM ON R/C



**T**HE subject of muffled engines is being explored in greater depth as each month passes. The model mags have devoted many pages to the subject, and as a result, have raised many arguments, both pro and con.

The modelers, themselves, have done some exploratory work on the subject, and even a few brave ones have purchased mufflers to try on their own mills. In England, of course, the use of mufflers is required, as they are in certain parts of the Eastern United States. The rest of our own country does not have any laws governing their use **as yet** — at least, none that I know about, so the few modelers that do try them are usually scoffed at for being slightly off their rocker! Like — “Why should anybody want to put one of **THOSE** things on his engine when he doesn’t have to?”

Back in the easy days prior to WW II, when the only model activity was free flight, there were not many noise problems. When Jim Walker and Ken Willard patented the U-Control process, and Jim set the nation agog with his Fireball, the modelers moved into town and set up shop on any convenient school ground or park. This didn’t last long as dozens of angry neighbors hated the sound of the wa-wa-wa. Soon, it became almost impossible to use any engine inside the city limits of most towns until the ½A size came along, followed close behind by plastic ready-to-fly’s.

R/C came along next, and once more the move was back to the country. This time, the great population wave (or, “what do you do when you turn off the Boob Tube?”) began to sweep over the land, and what was once the country, now became the suburbs, and finally, the towns. At the same time, the intrepid RC’er was boosting himself up from ½A ships and one minute tanks to .15’s with clap throttles, then to .35’s, and on up. The first .45 wasn’t too loud, but very shortly the big engines began to make an appearance at the field. When the Fox .59 opened its mouth, it let out a roar that completely drowned out the rest.

The only louder roar was from the angry mob of people living within a mile of the flying field. Did you ever stop to think that if we lived and operated in one of the mob-ruled countries of the world we might be stoned, spat upon, burned at the stake, and otherwise made to feel just a bit unwelcome?

Even now, the pages of this and other

magazines, are beginning to tell of wonderful new engines for our use. Power is up, displacement is up, the sky is the limit. How loud is the new .74 going to be? How about the forthcoming .80 and .90? Here, in the wide open spaces of Texas, we can always move a little farther out of town. Not so in other parts of the US of A. Many places have trees, hills, rivers, oceans, and **PEOPLE** to block any movement.

When we, quite recently, lost our five-year-old flying site to a group of irate homeowners, one of them expressed the situation pretty darn well when he said — “If a horse fly buzzes past you, you hear the noise but it really doesn’t bother you. If he stops and flies around your head then the constant buzzing gets on your nerves and all that you can think of is to track down that

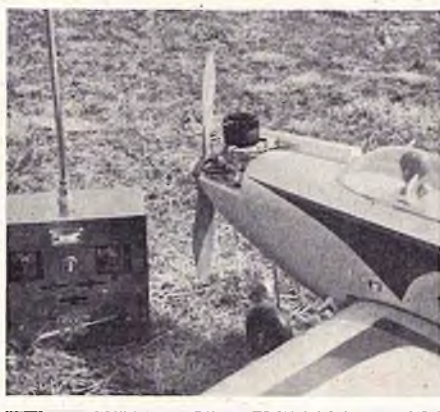

damn fly and squash it!”

He’s right . . . eight to ten hours of constant noise every Saturday and Sunday does get pretty bad, year in and year out. Several studies have been conducted concerning this very problem — trying to determine just what is an acceptable noise and how to reduce our sounds to that level. Nothing is totally acceptable to everyone. Many individuals don’t like the sound of a lawn mover or power edger, but since almost everyone has a lawn to care for, this noise is taken as a part of modern life. The same can be said of TV commercials — I don’t like them because they seem to be louder than the rest of the program. Almost any noise that we, ourselves, don’t create is bothersome to all of us. It’s the same thing with our models. **Everyone** doesn’t fly, so why should they have to listen to it?

Model engine design has come a long way since the mid-thirties and the power factor has skyrocketed accordingly.

But, like the automobile, we now seem to have as much power as is really needed, if not more. I’m not advocating that we develop no new engines, nor am I trying to lead a crusade against the big mills — I’ve flown a Fox .59 for three years now — what I **am** interested in is to challenge the engine manufacturers to spend as much time and effort in making the existing, and forthcoming, engines as quiet as they are powerful.

The new Cox engine is a step in this direction. With the know-how that is possessed by the engine makers, I’m sure that effective mufflers can be added to existing engines and, in fact, **improve** performance. Since the potential sales for muffled engines is high, the motive **should** be there. It may take a complete redesign of the engines as we know them today. Perhaps an exhaust opening out the bottom is the answer, feeding into a muffle placed along the bottom of the aircraft and ducting the burnt fuel away from the ship.

Regardless of the methods employed, until it all comes about, we — all of us — should spend some time exploring ways to quiet the engines we now own. Some of us have lost our flying fields due to our own stubbornness in not trying to silence our engines. You, and your club, could be next. When our field was in jeopardy, we began to investigate the muffler situation, and good buddy Helmar Johnson purchased one of the commercial types to fit on his Veco .45. The laughter from the doubting group rose to a high pitch when his engine loaded up so badly on the ground that he was unable to even taxi for takeoff! Other mufflers were investigated and found to be nothing more than sound cans to fit over the end of the exhaust!

We felt that there must be something more to the business than simply a tin can over the exhaust, so a trip to the library brought out a book on Internal Combustion Engine Design. The very brief section devoted to mufflers did reveal some very interesting information — the straight-through muffler principle seems to have worked best for lawn mowers, motor bikes, sports cars, and other fast running engines, so why not apply the same type of design to our model engines?

As the book said, straight-through mufflers were to be used on very fast engines, and for best results, should have a tuned stack. Applying the information gleaned from the text book, we came up with a muffler design that has, so far, worked surprisingly well. This type of muffler has been tried on a Merco .49, Veco .45, Fox .59, Ueda .45, and Ueda .55. In each case, all of the engines were silenced to a degree that we didn’t think was possible. Furthermore, very little loss of power was noted and

(Continued on Page 60)



JERRY KLEINBURG

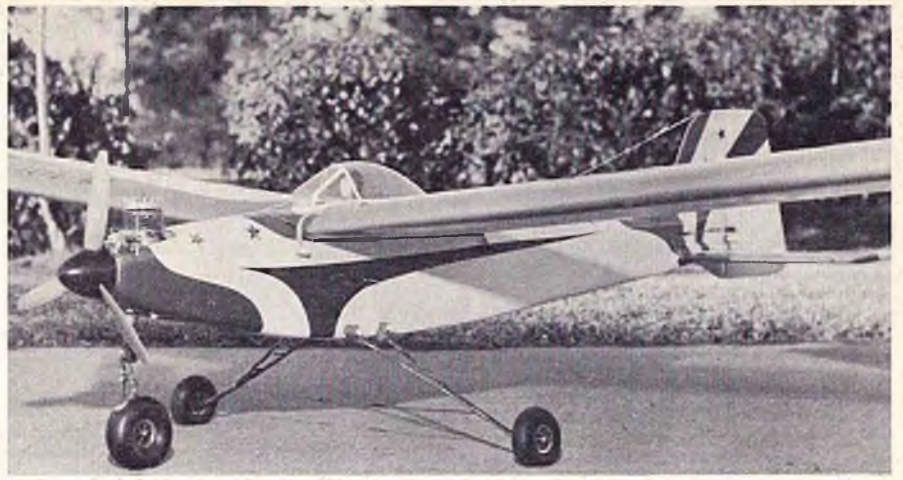

Jackie Gardner's Penetrator, winner of the 1966 King Orange Internats. Now sports Orbit analog propo radio and a Merco 61 to haul the 6¼ pound bird and its 20 ounce wing loading. Ship is aptly named—handled well in stiff Miami breeze. Also for Class II. To be featured in RCM.

IT'S pretty trite, in a way, but it may be fair to say that mention in the April issue suggesting enlargement of Class I activity to international competition levels sure uncorked some bottled-up feelings among rudder-ites. Reaction to Maynard Hill's CIAM report was immediate, and in many cases, comment went beyond this single facet of Class I ambitions. Limiting the comment to the matter at hand, here's a sampling of what letters received so far say about FAI:

*I would very much be interested in seeing what the other Class I flyers around the world can do. I expect they would like to know what we're able to do — and actually, isn't that what it's all about? It seems to be a bit short-sighted where only one category is considered important. . . . It's not too early to start the 'missionary' work. . . .*

Harrison Morgan  
Suncook, N. H.

*Class I is not being supported much.*

*I have the feeling Class I is tolerated but not encouraged. . . .*

Walt Staff  
Salt Lake City, Utah

*We feel that Class I should have a chance at FAI!*

Bob Moore  
Buddy Brammer  
Norm Rhodes  
Port Arthur, Texas

*The idea of Class I in FAI intrigues me and I have discussed it over many cups of coffee with many flyers I have come in contact with. All are in favor and are willing to help further the cause. . . . A problem seems to be lack of contact from other countries. Once this idea is introduced in other countries I am sure it will have definite appeal. A recent U. S. contestant in the Canadian Nats said flyers up there were impressed with the performing ability of his Class I plane in winning the top spot there. Many Canadians previously considered such maneuvers impossible with only*

*rudder and engine. . . . As for that guy who suggested we come up with a new event such as PAA-load, I suggest he make it a Class III event!*

M. C. Reed  
Canton, Ohio

*Class I is being treated like the underdog — and shouldn't be!*

Howard Ritter  
Gobles, Michigan

*I read with interest the comments (from Hill). They would seem to indicate the fate of Class I is well defined — up the creek! I have always felt that we have had to take a reluctant backseat to the Class III boys. Our club (Utah State Aeromodelers) is promoting a program, starting now, of Class I contests to support growth. . . .*

Aaron Saathoff  
Salt Lake City, Utah

*It seems to me that Hill's comments are pretty far off. Actually, he's recom-*

(Continued on Page 67)

George Gorden and his Sigma, winner of Class I at 1965 Wright Bros. Memorial meet. Annual Dayton, Ohio contest is set for 18-19 June. Will be staged by WORKS.



Curt Brownlee grins congrats to Ted White at 1965 TORKS meet, while C. G. Hoover, Len McCoy share honors. Ted won almost everything — except Class I. TORKS 1966 shindig set for 28-30 May.





By KEN WILLARD

RCM's camera records a segment of the several thousand visitors to the 1966 Weak Signals Toledo Conference.

**W**ELL, here I am, finally, at 29,000 feet and on my way to Toledo for the annual Weak Signals Mid-Winter Radio Control Conference. Nestling snugly at my feet — after unbelievably complicated arrangements — is “Top Dawg.” It’s quite a story!

Before I begin, I guess I should apologize to all of you. I promised to publish the “Top Dawg” plans this month but I forgot, momentarily, about the new things which would be shown at Toledo, and which I know you want to hear about. But next month, for sure, “Top Dawg” plans and construction hints.

Now, let me tell you about the “Dawg’s” flight to Toledo.

I figured it was a good idea to show the model at the Conference, so that all the equipment manufacturers could see how their receivers, servos, actuators, escapements, etc., could fit in the small ship. Same for the engine men. So, I put in a call to my friend Bud Garcia of “the friendly skies of United.”

“Bud . . . I’d like to go to Toledo.”

“Great, Ken. When?”

“Next week. And, Bud . . . I’d like to take a radio controlled airplane along with me.”

Short pause.

“You mean fly it alongside the DC-8?” A note of apprehension was apparent.

“No, no, Bud. It’s only a model racing airplane, controlled by radio. It has a three foot wingspan, and that’s larger than the airlines usually permits in the passenger cabin.”

“Oh,” said Bud, with obvious relief. “I think we might arrange something. How big a package will it be?” This innocent question eventually led to quite some confusion.

“Well, I de-mount the wing and place it alongside the fuselage and then it fits in a plastic bag about three feet by nine inches by one foot, or thereabouts.” (Note that I mixed in nine inches with the foot measurements.)

“Oh, then that’s no problem. We can arrange to stow it behind the seats at the divider bulkhead between first class and tourist.”

“Great! Then it’s all set?”

“Yes, but you won’t operate the radio, of course . . . will you?”

“Oh, no, Bud. As a matter of fact, it has a sort of new control servo which I’m sorta’ keeping confidential until I publish it.”

“Fine.”

So the flights were arranged, and I went over to the local ticket office to pick up my reservations. That night, the phone rang.

“This is United calling. Since you work at Lockheed, how come they didn’t make your reservations for you through the Traffic Department? Especially since you are carrying secret equipment? We don’t want any trouble with the security people!”

*(Continued on Page 62)*

The newest miniature proportional system from Glass City — the Miniplex. For .020 through .049.

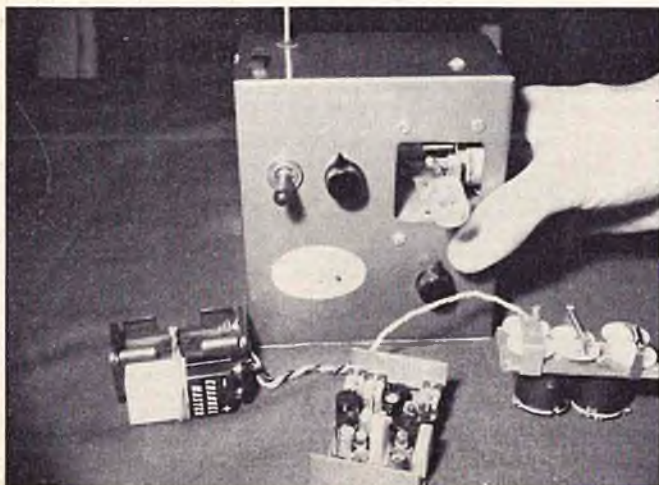

Rand’s new low wing design for GG, featuring the LR-3 actuator and an all-new superhet from Min-X. To be featured in RCM.

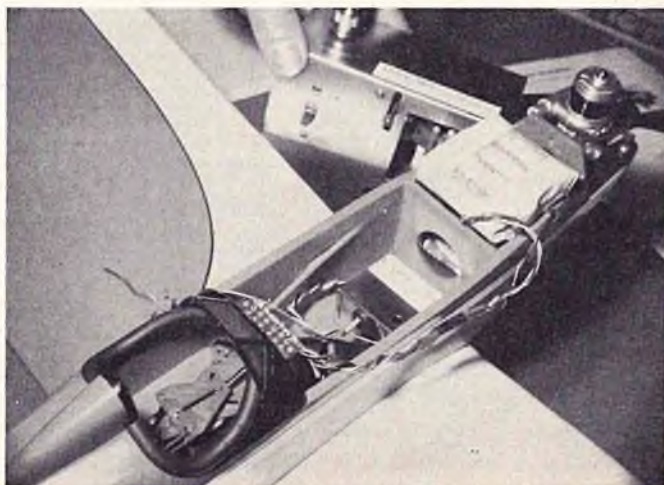

# PFIFF

## THE MAGIC BIPE

SINGLE CHANNEL,  
REEDS, OR PROPORTIONAL;  
PFIFF IS PURE MAGIC  
IN THE AIR.

by JOHN GARDE

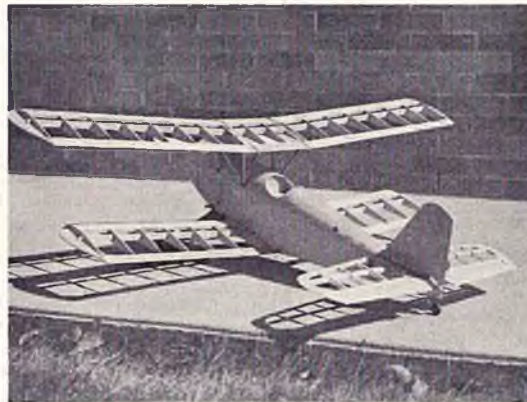

*The magic of the  
biplane of yesteryear  
is captured in  
the Pfiff.*



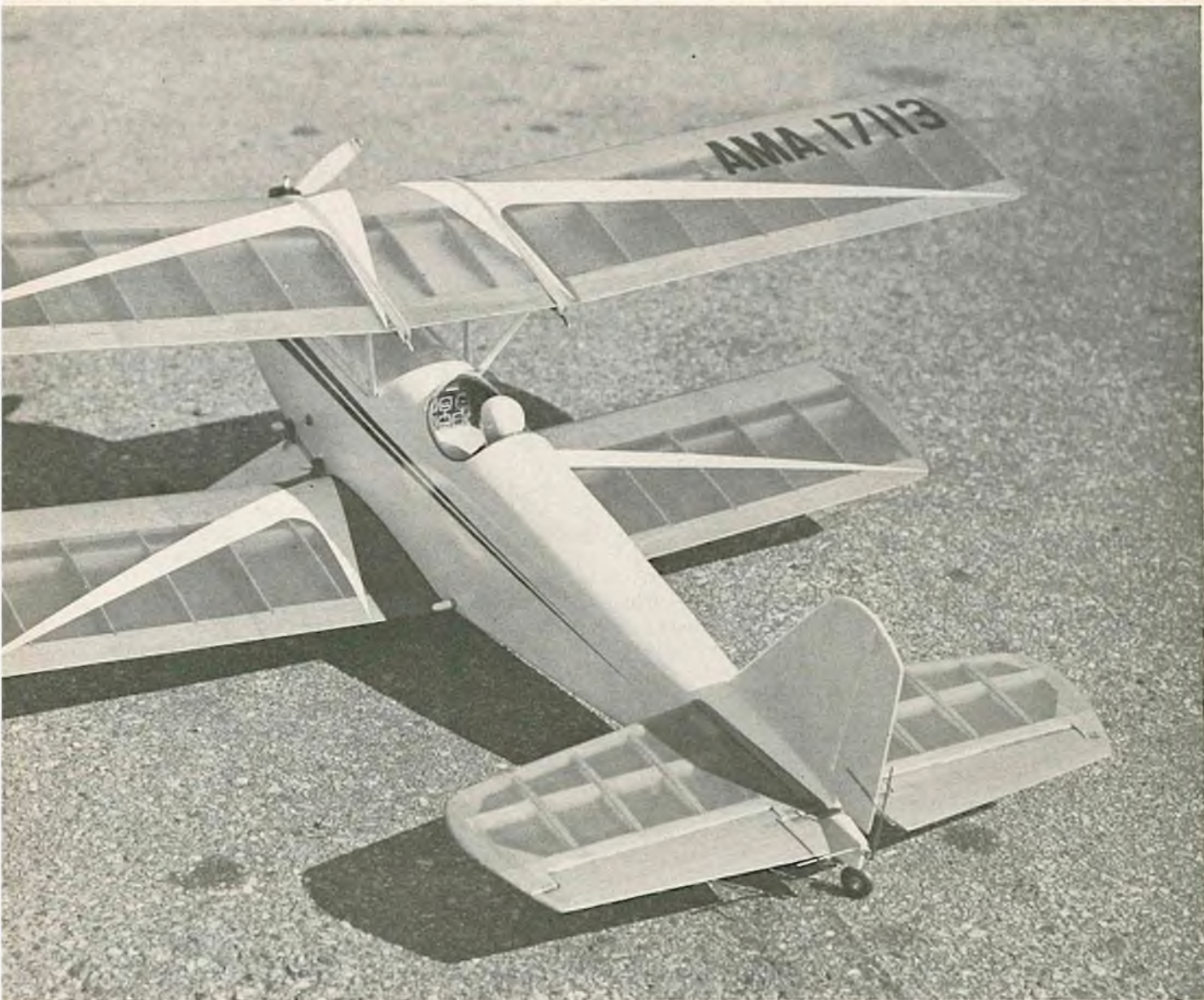

**I**N August of 1963, my family and I saw our first air show in Stormville, New York. There, before our eyes, we thrilled to Stearman's modified Great Lakes's Trainers and Rod Jocylen's little stunt biplane performing sensational stunts and maneuvers over a dirt strip airfield. I had been toying with the idea of building a winged "hot rod" like all the other "Big Daddys," down at the local flying strip, but, man was my mind ever changed. Now nothing but a "Bipe" would do!

Previously, I had built a popular 1/2 A Bipe. This little Jewel was a lot of fun but did not perform too well in windy weather (5-10MPH). Perhaps I expected too much.

With enthusiasm and determination the plans for my dream were begun. This model would be stable in windy or gusty weather. She would respond to rudder going down wind, either dead stick or low motor, she would groove in a turn without dropping her nose, be rugged enough to survive rough landings, including the three point kind

(two wing tips and a rudder), she would have eye appeal and would not stall suddenly in gusts. Last but not least, she would be simple enough to build and fly so that the average Joe could achieve maximum relaxation and enjoyment from her.

Keeping in mind the goals that I had set, I started in October of 1963 with pencil, slide rule, paper and a large pile of erasers. You see, I had never designed a model airplane before, nor was I trained in mechanical drawing. I did not finish the plans until late in January of 1964. Construction began in February and the first flight was the ninth or tenth of October. One year from conception to completion.

Its maiden flight was "right off the board" and it required only one trim change to achieve acceptable flight. Later, a friend built one using these plans except for a total weight of four pounds and a Torpedo 19. It flies just as well as mine. Still another is currently being built for R.E.M. proportional with no major changes other than motor

size.

Pfiff is 32 inches long, has a top span of 44 inches, bottom span of 39 inches, and equals chords of 7 3/8 inches. It is equipped with a Torpedo 15 with homemade throttle, nicads, F & M superhet, dual Varicomps and a modified OS motor control escapement for three speeds. It would be excellent for the new trio of Royal servos or six channel. The front half of the fuselage is fibreglassed. The original colors are white and red. The weight is 3 1/2 pounds, with a wing area of 596.5 square inches. The wing loading is approximately 13 ounces per square foot, unless my math is incorrect. Now, if "Pfiff" appeals to you as it does to some of my flying buddies, let's get started.

If you are a beginner in RC and have not graduated from the Mombo, Esquire, or Live Wire Trainer type models, this is not yet the plane for you. With short coupled tails biplanes are more sensitive than the trainer type.

#### **FUSELAGE CONSTRUCTION:**

After studying the plans you will no-





*On medium speed, and with reeds or proportional, Pffiff will do the Class II pattern with ease. We have done hammerheads, wingovers, loops, Immelmans, and sloppy tail slides even with escapement!*

tice that the sides are one piece, cut from 4" x 36" Sig  $\frac{1}{2}$ " soft. Cut-in the air foil for the lower wing carefully maintaining that 0° incidence, also note the stab is 0°. After gluing the  $\frac{1}{8}$  square and  $\frac{3}{16}$  square longerons, plus the  $\frac{1}{8}$  medium balsa doublers to the inside of the sides, glue the sides together at the tail, using a small  $\frac{1}{8}$  tapered block, allow to dry well. Incidentally, use only white glue, it gives the most strength and you will need it on hard landings. You can use contact glue for the doublers, but **not** the cabane plywood.

You should have all the formers ready by the time the sides are finished. Start with F2 and work back A, B, C, D, but take it easy! This plane has to be lined-up perfectly. This saves all the questions later when you are ready to fly. While the formers are setting up, get the  $\frac{1}{8}$  plywood out and knock out the doublers for the cabane anchor points and support.

**CABANE:**

If you are more excited about the Bipe than you were before, good, but settle down Dad, everyone tells me the cabane on any Bipe is rough going and you have to make it now. Ready? Let's haul.

Bend the 90 mil cabane struts ex-

actly as the plans show. There are two, friend. Throw the bad one away and make another, the wire is cheap! Make them alike, matched pair, twins, dig? Now draw, trace or whatever you wish, the outline of the cabane struts on the plywood doublers, and carve the grooves to accept the struts you just completed. NOTE: Grooves are on the outside of the doublers, i.e., between doubler and fuselage side. Also note that maintaining the angle of the rear cabane strut as shown on the plan, you will be building in a 3° incidence, which proved to be fine for both 3½ and 4 pound Bipes of this kind. Now cut the square and round holes in doublers, as shown on the plans, wire and epoxy the struts in place. Epoxy in the **groove portion** only, leaving the holes open for later filling. Place the strut and doubler assembly on a level table. Using a level, move the struts up or down to level the cabane before the epoxy cures. Level sideways, not front to back. They should not be too far off if you cut the grooves in the doublers very close beforehand.

Now you are ready to put this assembly into the assembled sides. Smear white glue on the outside of the cabane  
(Continued on Page 22)

*If you don't care for all that fancy stuff, Pffiff is a pleasure to watch just flying around at 25 mph — not 70 mph. There is a bit of nostalgia in the air when she is flying up there . . .*

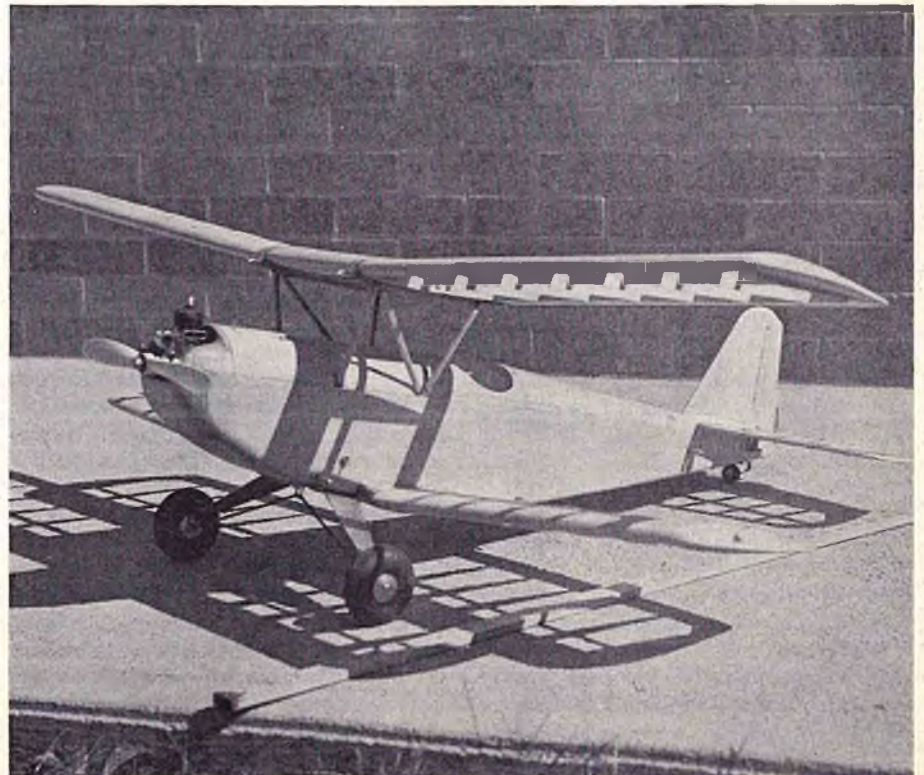

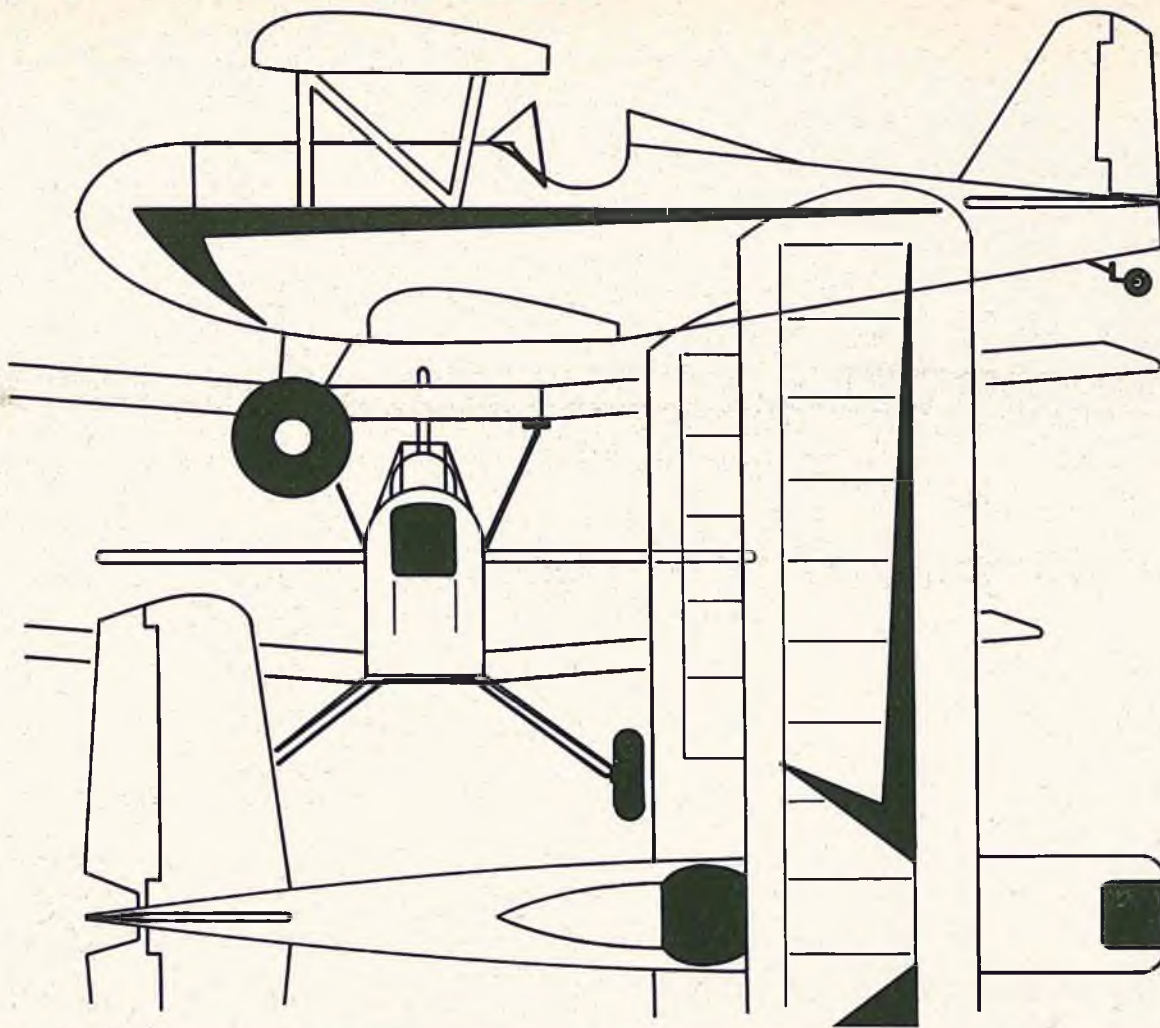

**ENGINE**

Use a .15, .19, or .23 engine. A .15 may be used with light weight equipment and where all-up weight does not exceed 3¼ pounds. For 3½ to 4 pounds flying weight, use a .19 or .23.

**DIMENSIONS**

Top Wingspan: 43¾" Chord: 7½"  
 Lower Wing Span: 36¾" Chord: 7½"  
 Total Wing Area: 560 Square Inches  
 Fuselage Length: 33"  
 Max. Fuselage Width: 3½"  
 Engine Offset: 5 degrees right  
                   6 degrees down  
 Incidence: 3 degrees positive, top wing  
               0 degrees, bottom wing  
               0 degrees, stabilizer

**FLIGHT CHARACTERISTICS**

Stable, responsive, capable of all Class II maneuvers, depending upon engine size and equipment used. Surfaces, as shown, are balanced for use with escapements or simple proportional.

**RC EQUIPMENT**

First prototype used cascaded Varicomp escapements for rudder and elevator and SN escapement on throttle. Later versions used six channel reed equipment and proportional. Adequate room for newer "full house" propo gear.

**MATERIAL LIST**

(balsa unless otherwise specified)

**Wings:**

- (4) ⅜" x ½" x 36"
- (4) ⅜" x ½" x 36"
- (4) ⅜" x 1¼" x 36" T.E. stock
- (8) ¼" x 3" x 36"
- (1) ⅜" x 2" x 36"
- (1) 6" x 12" x ¼" plywood
- (2) ⅜" x 3" x 36"

**Tail Group:**

- (1) ⅜" x 4" x 36"
- (2) ¼" x ⅛" x 36"
- (2) ⅜" x ¼" x 36"
- (2) ¼" x ¼" x 36"
- (1) ¼" x 1" x 36"

**Fuselage:**

- (1) 6" x 12" x ⅛" plywood
- (1) 6" x 12" x ¼" plywood
- (1) ¼" x ¼" x 36"
- (2) ⅜" x ⅜" x 36"
- (2) ⅛" x ⅛" x 36"
- (1) ⅜" x 4" x 36"
- (2) ¼" x 3" x 36"
- (1) ½" x 4" x 6"
- (1) ¼" x 3" x 36"
- (2) ⅜" x 4" x 36"
- (1) ¼" x 36" dowel
- (1) pair 3½" DuBro wheels
- (1) radial motor mount to suit engine
- (2) ⅜" x 36" music wire
- (1) dural landing gear
- miscellaneous hardware

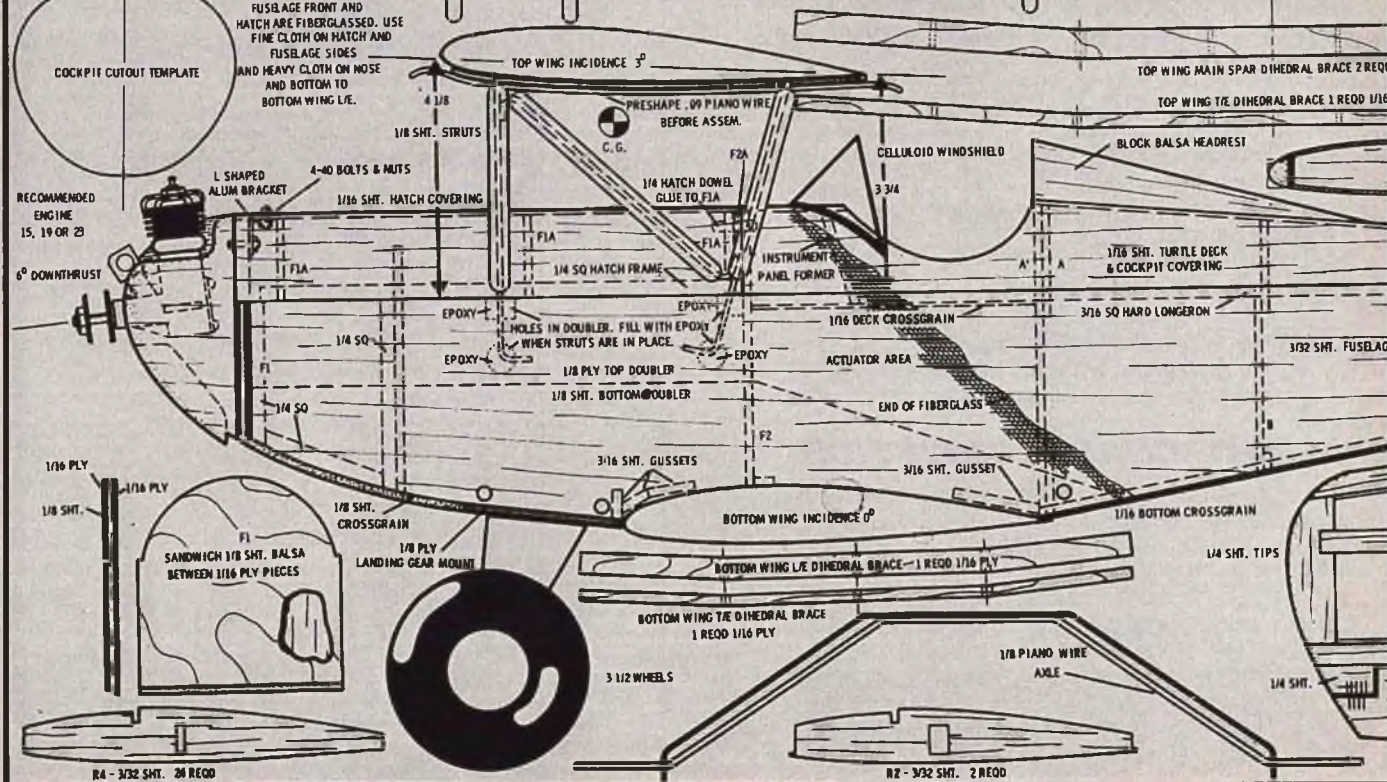
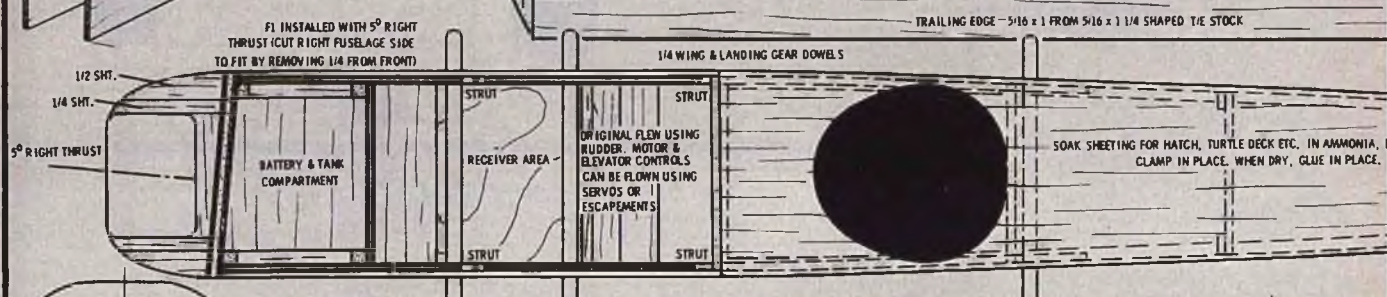
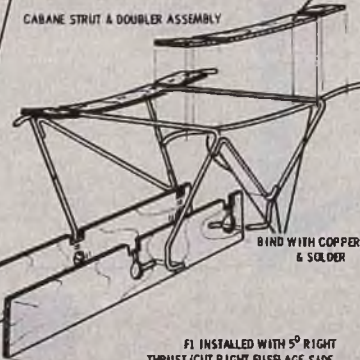
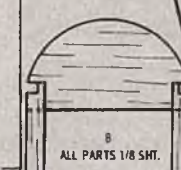
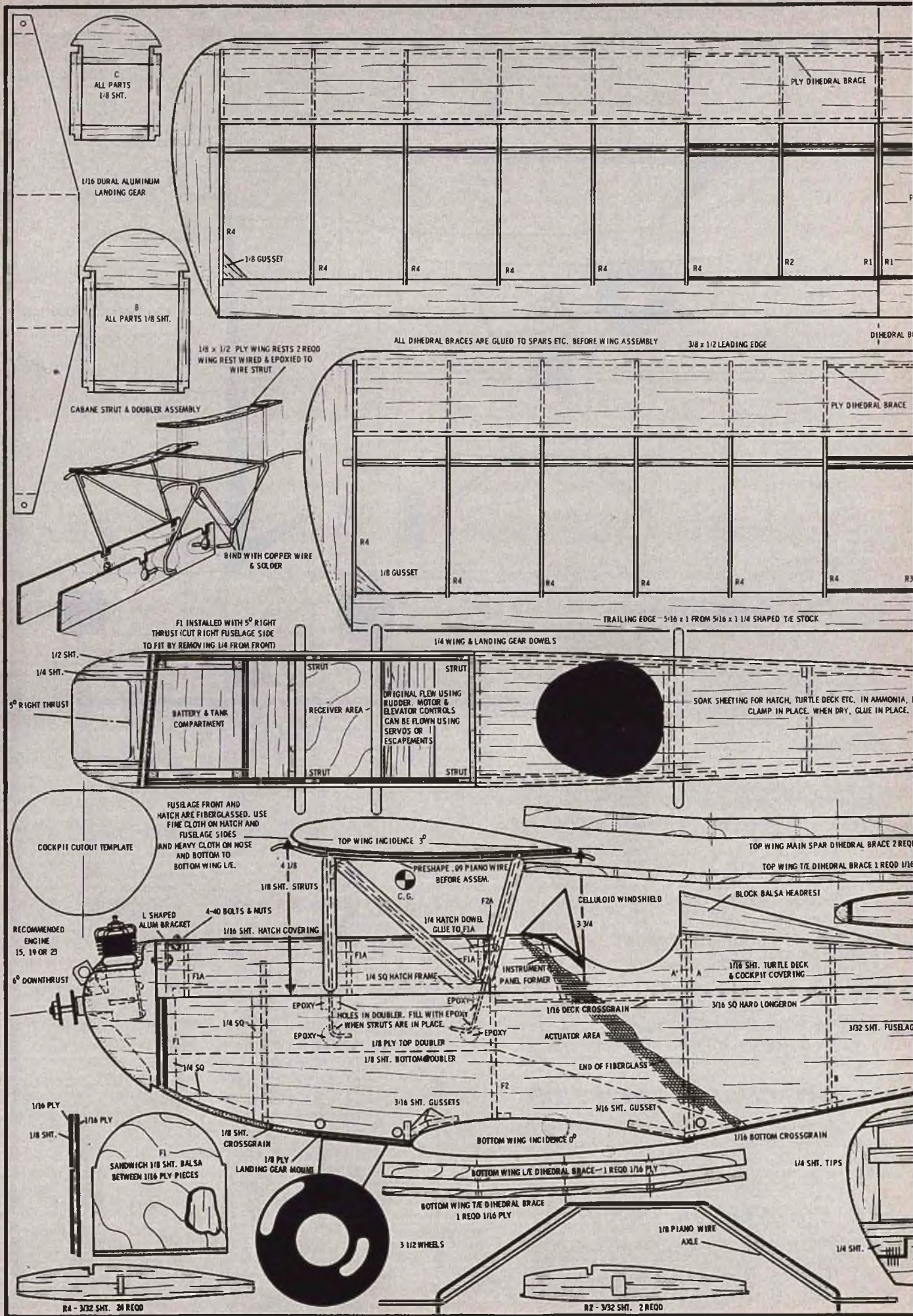

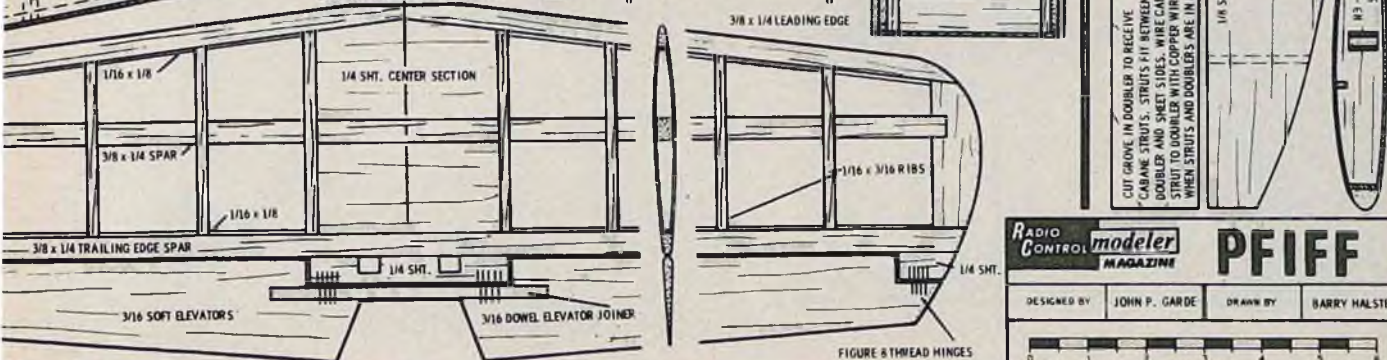
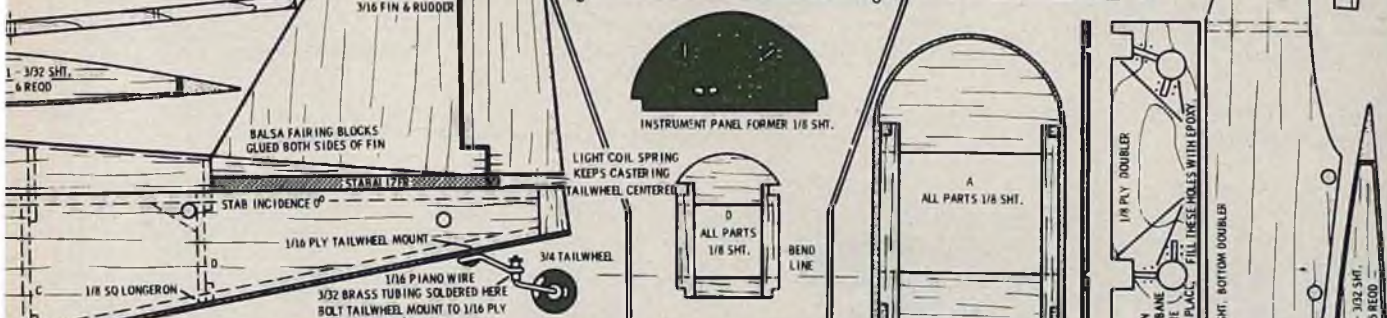
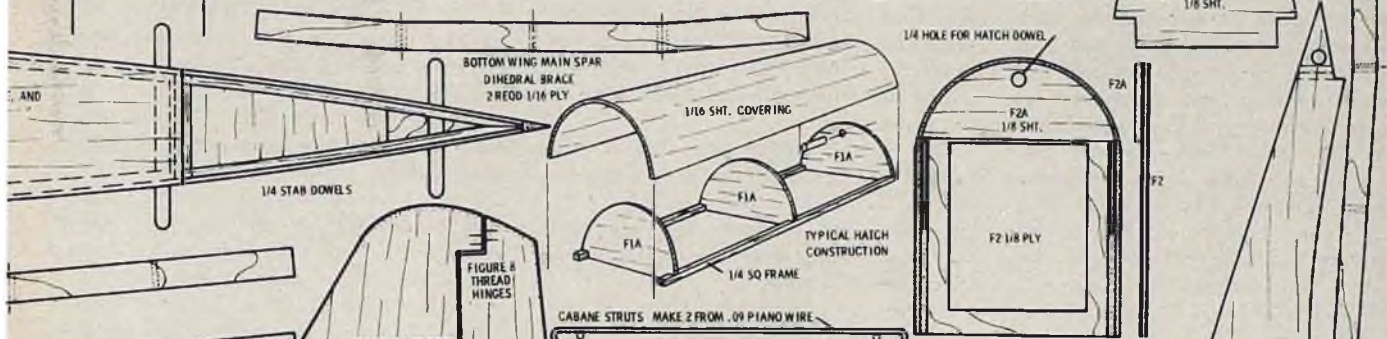
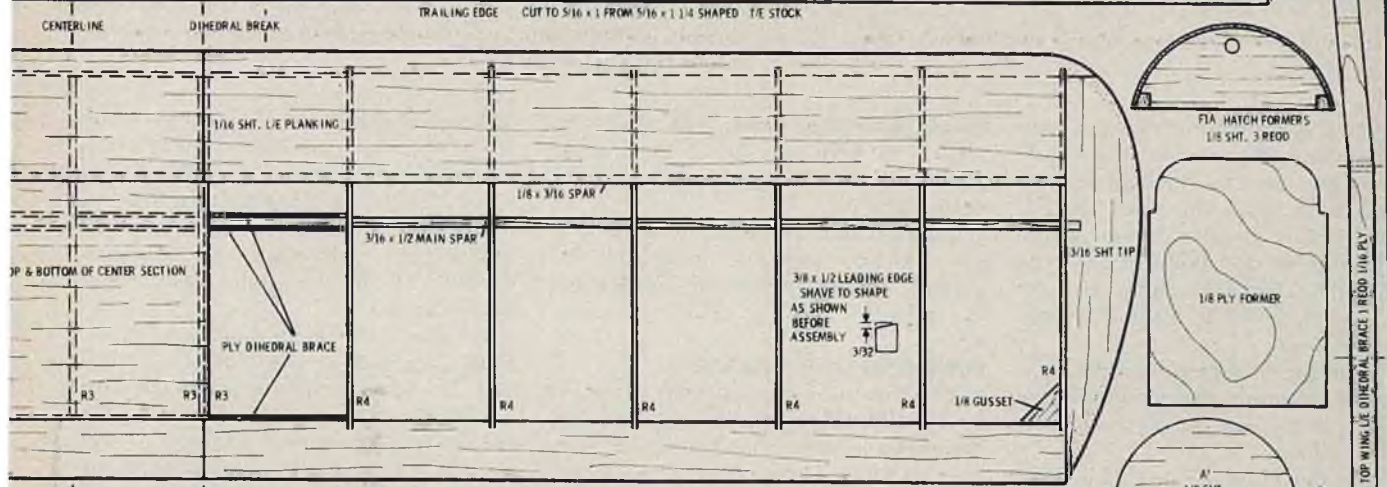
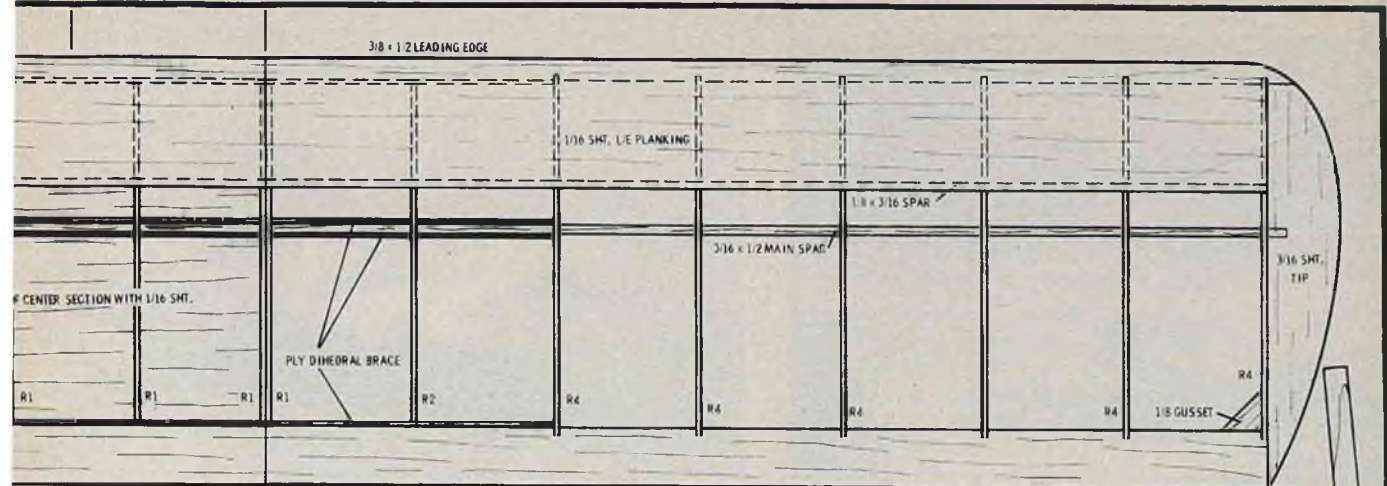

**RADIO CONTROL modeler MAGAZINE**

**PFIFF**

DESIGNED BY JOHN P. GARDE DRAWN BY BARRY HALSTED

TOP SPAN 43 3/4 IN. BOTTOM SPAN 36 3/4 IN. AREA 360 SQ IN.

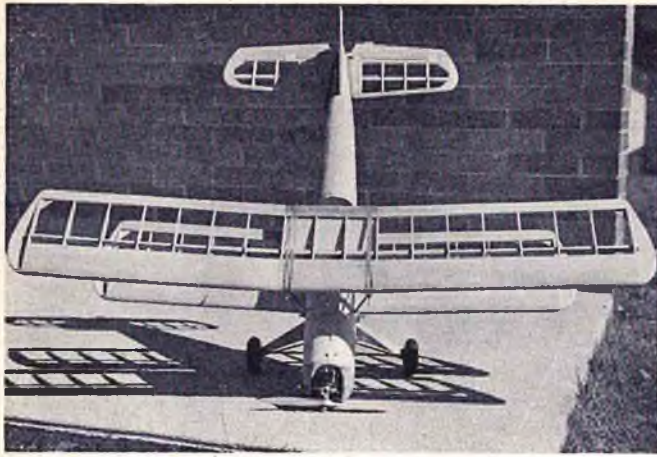

Basic structure, sans covering. Strong and light weight.



Completed Pfiff turns in outstanding sport performance on virtually any equipment combo.

doublers. Have plenty of clamps or inverted clothes pins ready. Now slide the assembly into the fuselage, engaging and flush with the back of F2. Clamp doublers to sides, lining up the straight edge of the doublers with the straight edge of the fuselage. Hurray! It's in. Let it dry well. Make F1 while you are relaxing.

Mark off the fuselage for that 5° right thrust (F1 mounting position) and glue in, also, glue in ¼ square gussets at bottom and sides.

Now is the time to put the cross grained bottom of the fuselage on, note the plywood for landing gear, and also put the turtle deck and cockpit on. Leave the bottom rear uncovered at this time. On the plan I have noted that to form the turtle deck, cockpit and hatch, I use ammonia. That is regular household ammonia. It is better than water or steam. Cut the ¼ sheet to the approximate size you will need for the turtle deck and soak in the ammonia. The ammonia will cause the wood fibres to actually slide. When the wood has dried upon the form it is to be glued to, you can release the clamps or rubber

bands and the wood will retain its shape. It will not spring to a larger radius. So don't look stunned, it really works, try it.

Considerable thought should now be given to how you will install your RC system. Install it while the bottom rear is still open and the cabane is unfinished.

#### FINISHING THE CABANE:

Preform the wing pad wire struts. It is not difficult if you use a small vise, hammer and pliers that have good gripping ability. Secure the wire in the vise, then, while pulling the wire with pliers, tap it in the direction desired. Gradually work in the curves from one end to the other and match the wire to the plans often.

The formed wires have two advantages. (1) They, with the plywood, provide an accurate cradle for the wing, (2) the bend prevents the plywood pad from sliding back and forth if the epoxy bond loosens.

Secure the pad struts to the cabane struts on the fuselage with #22 AWG copper wire and solder. Secure them to the underside of the cabane struts.

Maintain right angles the best you can. If you have had trouble soldering piano wire in the past, try using stainless steel flux by Kester Solder Co. Continue by bracing the top of the cabane diagonally with .010 - .015 piano wire. Draw it tight to obtain the right angles mentioned before.

Bend up the side diagonal braces. Bind with wire to the cabane and solder. The fuselage can be protected with an aluminum wrap. The plywood pads are next. Cut two ¼" x ½" x 7/8" plywood. The ¼" pad is actually in three pieces. The first one is from the L.E. to the front of the first cross strut, the second is between the two cross struts and the third is from the rear of the rear cross strut to the T.E. Total length is 7/8" including the space or gap for the cross cabane struts. Put several cuts half way through the plywood with a razor blade, 90° to the formed wire pads so you will be able to fit the front and middle pads to the formed wire pad. Space about 1/8" between cuts at the bottom of the pads. Now drill

(Continued on Page 77)

First prototype in 1964 used cascaded Varicomp's — did rolls, Immelman's, tail slides.

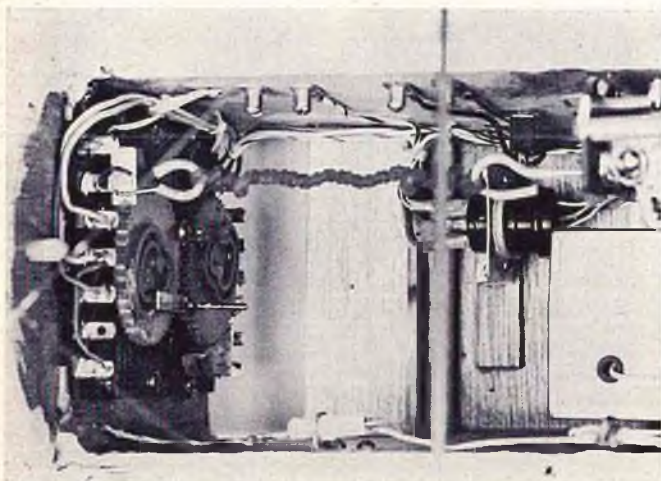

Detail shot of suspension type tail wheel.

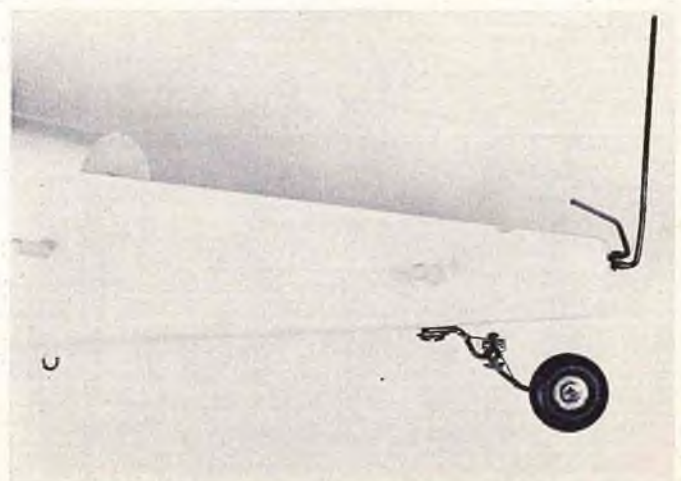

# TOLEDO!

**KITS AND PIECES VISITS THE BIGGEST SHOW OF THE YEAR. FOLLOW BERNIE MURPHY AND CHUCK WAAS AS THEY TOUR THE SPECTACULAR 1966 WEAK SIGNALS TOLEDO CONFERENCE.**

**O**NE glance at the crowd at the recent Toledo Conference gave me the impression that RCM's coverage of the event was almost unnecessary. The 12th Annual Mid-Winter R/C Conference and Exposition, sponsored by the Weak Signals Radio Control Club was unquestionably the best attended event of this type ever presented by an individual club. Paid attendance topped the 3300 mark, exclusive of women and children and exhibiting manufacturers, all of whom were admitted free! At the present growth rate of the "Conference," by 1970 there will be no place large enough to hold the crowds!

Saturday's program included a morning of display activity and movies, including NBC's "Sports In Action" show of the 1965 Nationals and excellent films of NMPRA pylon racing and slope soaring. The afternoon was spent, alternately listening to informative and interesting talks by such outstanding R/C personalities as Carl Goldberg, Hal deBolt, and Ken Willard, plus trudging through ankle deep mud (in lieu of the usual foot or more of snow) to watch the spectacular flying demonstrations.



Jimmy Grier, Don Lowe, and Ernie Huber seemed to be running their own small contest as each tried to outdo the other in the limited field area. Around the floodlight towers, under the lines, and over the roofs they flew to the cheers and applause of a well-pleased crowd of somewhat muddy spectators.

Sunday proved to be pretty much of a carbon copy of Saturday, with the addition of the Award Presentations.



Again, the weather gods blessed us with an unseasonably warm, calm day, and again the flying demonstrations were a big hit (in more ways than one!). Jimmy Grier managed a muddy rudder on an inverted pass under the power lines,



while Ernie Huber, flying a prototype of Lou Andrews' latest "Sportmaster," insisted on snap rolls at 20 feet. This combination of Andrews and Huber is hard to top! Ernie made the Sportmaster perform in a fashion you rarely see — a ship that hadn't even been test flown prior to the Conference! Lou seems to have that certain knack for designing a winner, and Ernie certainly makes the most of it!



In all, there were 43 manufacturer displays running the entire range of R/C equipment and accessories. Lanier Industries displayed each of their "ready-to-fly" ships, with an excellent flight demonstration of the Bronco, a real mover! These ships are constructed of Air-O-Sheet, a thermoplastic material designed for modeling use.



Midwest Products unveiled their latest in a larger "Squire" — the "Sky-squire," and a smaller "Cat," the "Pussycat." The latest innovation in balsa packaging was also shown by Midwest — clear plastic wrapping of their Micro Cut wood.



A one, two, three .049 size ship was shown by Myers Models. Why one, two, three? Simply because that's the way she comes. One, as a kit; two, completely built; and three, completed, built with engine and prop installed. (What happened to four, with radio?) The ship is the "May Fly," however we are sure it should be the "Will Fly!"



The long awaited Acrobat biplane was the feature of the deBolt display. This kit, along the same construction lines as the Jenny and P-Shooter, is a "quickie" to assemble, requiring an estimated 30 hours. Further along the line, Ed Manulkin was busily describing the features of Sterling's new Command

Master radio system, an ingeniously devised, self-contained unit.



No Toledo Conference would be complete without the smiling face of "Mr. Modeling," Carl Goldberg. Carl proudly showed his new Shoestring racer and a larger version of his popular Cessna Skylane (a future release) — both beautiful ships.



Dwight Hartman, the man who made all those fiberglass Taurus fuselages, had so much fiberglass lined up, I am certain he must have a constant itch. Wheel pants, cowlings, ring cowls, fuselages, the "Lil Knarf" kit, and his sailing sloop made quite an interesting display. All appeared to be well made.



Special Editions Plans (Kustom Kits) had both the "Scorpion" and their little "Mister E" under close scrutiny. We have built both of these kits and have found them to be excellent. Also new from this firm is the latest in the Co-Ac line of actuators. The newest version, featuring push-pull cam operation, eliminates the birdcage linkage and is certainly a big improvement.



Vern Krehbiel of VK Models must have really enjoyed his trip to Toledo. Every time I tried to get into say a few words to him, he was already engaged in a conversation with some happy RC'er who had built a VK Cherokee. Vern, if you had trouble getting your head through the door, we'll understand!



Jack Josaitis of World Wide R/C in Detroit, was out to let everyone know they had the goods. Judging from their display, it seems improbable that there is an R/C kit or accessory that they do not stock! At the next booth, Paul Gourley and his lovely wife tried to help the RC'er who is short on time, with the



Action Industries fiberglass Senior Falcon kit and their new Aeolus fuselage. Also from Action Industries, their Sky Writer smoke cartridges. These were used on several of the demonstration flights, making them even more spectacular.



At the GM Hobby display, Sonotone batteries and generally "hard-to-get" accessories were the feature. Further along the line, Lou Andrews was busily explaining the difficulties in obtaining suitable balsa for his outstanding "Aeromaster" biplane kit, as well as answering the many queries about the latest "Sportmaster."



Royal Products showed just about everything imaginable, from nose gears to tail wheels, and encompassing everything in-between! Engines, several different control systems, tanks, foam wings, and wheels, were but a few of the excellent Royal items.



Along the lines of radio gear, most of the latest systems were represented. Some of the systems that we had the opportunity to examine included Min-X, Logitrol, F&M, Airborne Control Labs (ACL), CitizenShip, Kraft, Proportional Control Systems (PCS), Bonner, Orbit, Micro-Avionics, and Controlaire — all multi, full-house rigs. In addition, World Engines displayed the Digitrio, RCM's pet. A new outfit, Airtrol, featured miniature pulsing proportional control for the small ships.

Fly-Tronics (sounds like an electronic zipper), showed several versions of their servo mounting and wiring board, even one with a Digitrio. The new galloping ghost LR-3 actuator from Rand Manufacturing was a hit with the R/C fans who like the inexpensive end of our hobby, or who just plain prefer small fun ships — with the accent on fun! I have personally flown the LR-3 and think it is tops — despite the efforts of our Fearless Leader to discredit the unit by placing it in one of his own ugly designs. The small ship (nameless) used by Rand for displaying their actuators looked like a real winner, and I am pressing (with a hot iron) our old

Editor to publish the plans. (Ed's note: We're way ahead of you, Bern.)



Mr. HobbyPoxy, Bev Smith, explained the use of the Wingamajig as an aid to covering foam wing cores with fabric and epoxy resin - HobbyPoxy epoxy, of course.



DuBro's vast line of R/C fittings, as well as their new low bounce wheels and new electric brake were available for examination. We have been flying the new wheels and brakes for some time now and are very pleased with both. The low bounce wheels make even **my** landings appear smooth! While



DuBro handled the landing gear department for the landlubbers, Gee Bee Line took care of the seaworthy fliers with their assortment of floats. A new addition to the Gee Bee series is polyethylene wheel pants (unbreakable even!).



The easiest wing construction technique was shown by A-Justo-Jig. This jig allows for the construction of a wing of any shape airfoil in one piece. The unique arrangement of the A-Justo-Jig allows the wing to be sheeted, exclusive of the bottom center section, while still in the jig, thereby eliminating twisting completely.



Often the simple approach evades the model manufacturer. Darin Bros. has introduced two simple accessories, an aileron horn and an elevator horn. The former is for strip ailerons, and is similar to the accepted crank, except that the vertical rod is threaded, and the linkage fitting is screwed on, allowing almost infinite height adjustment. The elevator horn is similar, but includes a mounting plate (can also be used for rudder or aileron).

Bobbie and Paul Runge of Ace R/C showed a sampling of their ever-increasing line, including the latest Jansson transmitter. Associated Hobby Manufacturers displayed a vast line of imported radio and engines, including the very impressive Ueda line of R/C engines.

Octura Models and G.E.M. tried to fill the bill with the R/C boat fans, with almost every imaginable boating component on display.



One of the most fun-filled exhibits was that of North American Hobbies. Tom Dion of NAMCO was proudly displaying their R/C 1/18 scale Mustang, complete with throttle and proportional steering. A small course had been set up using paper cups, and just about everyone had a turn at the wheel of this small car. Needless to say, yours truly dented a few cups.

Last, but far from least, the most impossible display to get close enough to see. Sid Axelrod, of Top Flite Models,

couldn't have drawn a larger crowd! Not even if he had brought along dancing girls clad in Silron! The interest centered around his demonstration of a new plastic covering material - Monokote. You will be hearing about this as the season progresses. Monokote is a self-adhesive material with 17% shrinkage capabilities - although it shrinks only until it meets positive resistance. It will not twist the lightest structure! The material is laid evenly in place and then ironed on! (Try using the little woman's iron on this one - how to end a hobby!) The results are amazing and it requires no paint or dope of any kind! Monokote comes in assorted colors and is **completely** fuel proof - also relatively **fool** proof!



In addition to the manufacturers display booths, several hundred R/C ships were displayed throughout the show, ranging from scale to whatzit, from average in construction and finish to unbelievable! During the entire show, a Swap Shop was operated where you could buy or sell almost anything.



The Toledo '66 Conference is over. Those who attended most certainly left with new hopes and ambitions. If you didn't make it this year, by all means plan ahead next year. My own reservations are already made! In a few words, it is impossible to relate the experiences and knowledge and pleasures to be found in one weekend with several thousand R/C friends.



# DEB-N-AIR

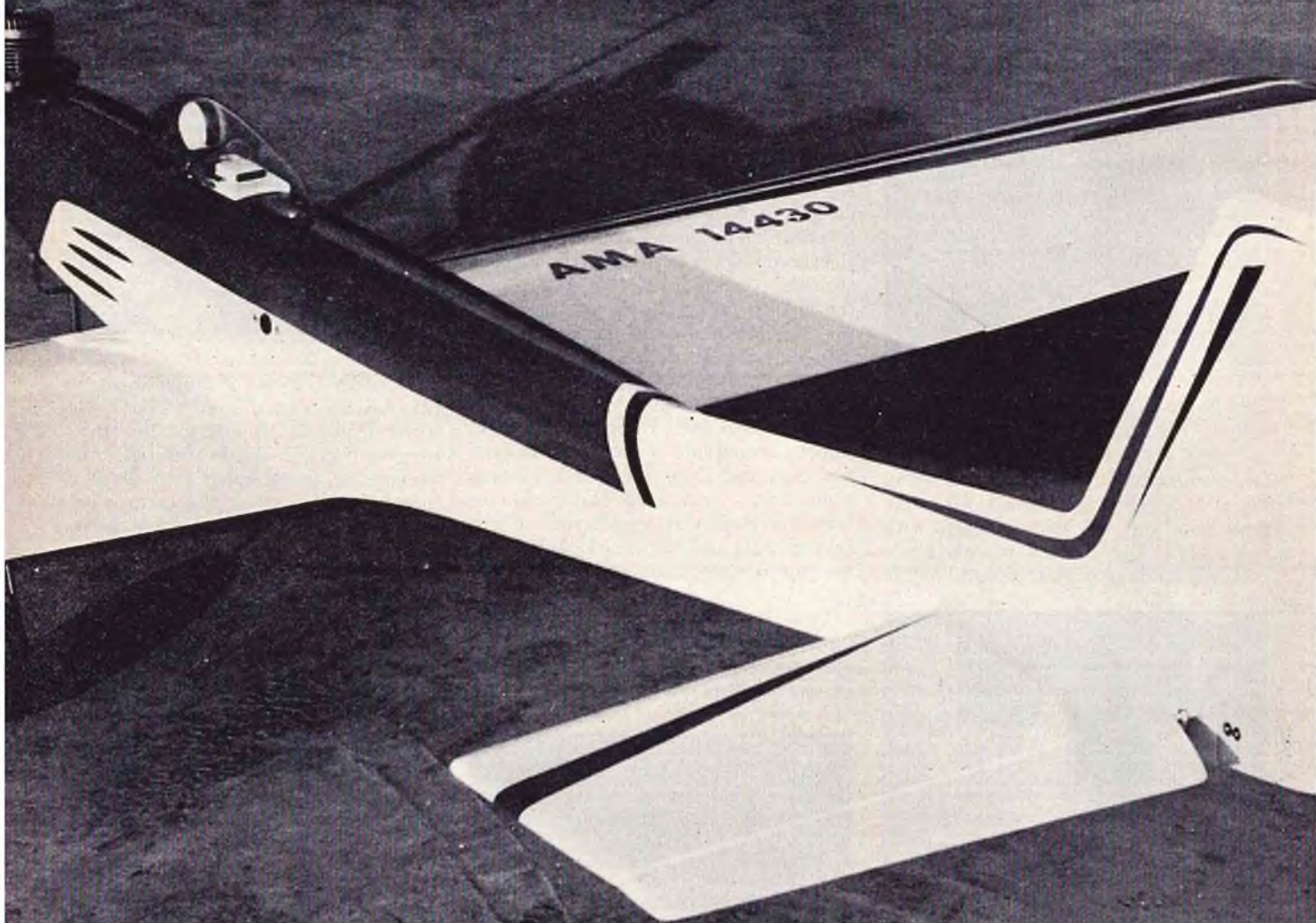

bryan lakin

**D**EB-N-AIR, — Beautiful, graceful, smooth — .”

That's what Daniel Webster says in the dictionary, and of course he's the undisputed LAST WORD! What's that you say?—he spells it D E B O N A I R ? Oh, well, technicalities; someone's always pulling the book on me!

Deb-N-Air is everything her name implies. She is easy to build, sweet and responsive to fly, and really is a consistent contest winner. In the air now less than a year, she has never placed lower than second place in any contest entered. At home she's the local "Belle" drawing "Oohs" and "Ahaas" each time she performs. How did the Deb-N-Air come into existence? Here's the story.—

After flying Stormers, Orions, Taurus's and various other high, shoulder, and low wing craft throughout the past few years, it seemed to me that there was still something missing in high performance multi competition aircraft. Since I had just come out on the short end of a head-on, mid-air collision last fall, I decided to look for something new and different. It seemed the first thing to do in choosing my next airplane was to write down a list of desirable traits we would like to see in a good competition machine, and then see if we couldn't find something to fit those specifications.

Our ideal airplane, first of all, had to have good ground handling characteristics. It should track out straight and true on the take-off run as well as through all inside and outside maneuvers, once in the air. We also wanted a ship that exhibited good, true axial rolls; both flat out and in the looping rolling maneuvers. The ability to drag-in for a landing at a smooth, safe approach speed without ballooning was a must in our set of specs.

Sound like a big order? As I began my quest for the perfect airplane, I began to think so, too. One popular type seemed to perform well in the pattern but was obviously squirming through the rolls. And talk about ballooning on the landings — just try to get a smooth approach in any wind at all with this one! (Incidentally, this airplane actually grooved better upside down than it did right side up.) Several of the other currently popular designs had pretty good roll characteristics and were good windy weather airplanes, but were not too smooth in the looping maneuvers and landed at far too fast a rate of speed. Still others flew well in a general fashion but had undesirable characteristics such as fish-tailing at high speed, zooming tendencies, and self recovering tendencies in a dive. Well, I'm sure you get the message by now. I simply wasn't satisfied with anything on the market, and so set out to design what came to be known as the DEB-N-AIR.

I have studied aerodynamics for several years now, especially as related to R/C, and have formed some pretty firm personal opinions as to what R/C designs should and should not do. I might add, that as a private pilot for about 15 years now, I have had some firsthand flight experiences to help guide my studies and opinions. However, I'll be the first to admit that there is virtually no connection between your ability as a pilot and your ability as an R/C pilot. (Beginners take heart!) Your knowledge of aerodynamics will help, and knowledge of control movements required will speed you along at a more rapid rate, but learning to fly the complete pattern proficiently, will take considerable time and practice. Maybe this is why we love the hobby so well; we never quite master it completely. There's always a new challenge ahead.

In designing a modern R/C high performance airplane we want many features similar to full scale aircraft and some that are completely different. Of course, the way you design anything is to first write up a set of ideal specs you would like the plane to meet, based on its intended usage, and then design around these specifications. Sooo — here we go — !

#### —SPECIFICATIONS—

“R/C Multi stunt design, neutrally stable, contest performance.

1. Power requirements . . . 45 to 60.
2. Good ground handling with sturdy gear. Plenty of clearance.
3. Straight take-off run with clean break from ground.
4. Straight and level climb-out with no tendency to increase climb rate as speed builds up.
5. Good grooving characteristics both right side up and inverted.
6. No tendency to fish tail as speed increases in a dive.
7. Good grooving characteristics with no tendency to zoom out in a straight vertical dive. Again we want no fish tailing as speed increases and would like for the speed to stabilize as a good speed-drag ratio speed is reached.
8. Rolls should be perfectly axial regardless of whether full ailerons or minimum ailerons are applied.
9. The aircraft should be able to maintain a constant continuous bank of 25 to 45 degrees with hands off by simply applying the necessary amount of elevator trim with no tendency to hook in or roll out.
10. Tail spins should be entered cleanly and rate of spin should be as slow as possible. There should be no tendency to hang in the spin or reverse spin, when controls are applied to stop the spin.
11. In yaw maneuvers such as the wing over the airplane should yaw tightly with no tendency to spin out

The Deb-N-Air is a competition and sport machine par excellence. Aerodynamically far ahead of most of the multi ships flying today, this is the one to watch in months to come!





*Extremely smooth  
in all maneuvers,  
continuous hands-off  
turns, proto  
landings, characterize  
the Deb-N-Air.*

over the top or roll during the yaw portion of the maneuver.

12. In looping maneuvers the airplanes should exhibit no tendency to roll out or yaw off to the side while climbing or diving.
13. Slow flight should be smooth and controllable with no tendency to spin out. It should not zoom up when throttle is applied abruptly, nor should there be any nose dropping when the throttle is cut.
14. Most important — on the final approach, there must be no tendency to balloon with the gusts. It must be capable of very slow approaches without danger of stall in order to make those smooth clean landings where the main gear touches first and then rotates forward onto the nose gear as the speed slows.
15. In general, our "ideal" R/C airplane should be extremely smooth in all maneuvers, fly straight as an arrow maintaining perfect wings level attitude, and holding altitude clean and stable. It should do continuous hands-off turns and slow dragged-in approaches with nice prototype landings.

After writing up these rather ideal specs we set out to track each desirable trait aerodynamically and to see what was necessary to provide the desired results. This led us to the library where

there, and at home, several weeks were spent analyzing and researching every book available. Definite design trends started to develop and the Deb-N-Air began to take form.

First it seems we needed a symmetrical airfoil of fairly thick section to give the desired grooving characteristics both upright and inverted. This also takes the pressure off those landing approaches by eliminating the ballooning tendencies, and recovery tendencies in diving maneuvers. It is worthy of note that a symmetrical wing positioned at 0° to the line of flight produces no lift until it is rotated to a positive degree. This accounts for its superior grooving tendencies and its insensitivity to gusty air on landing approaches. Its major disadvantage is its inefficiency for full scale aircraft, but of course, we're not interested in how many miles we get to a gallon of fuel in R/C so it has a definite application here.

While on the subject of stability, let's take a look at the fairings on the Deb-N-Air. Turbulence affects flight more than we'd like to believe, and turbulence occurs two ways. First, some turbulence just exists in the air from normal air currents. The other way is for the airplane to create it itself. If we could see some of our R/C models in a smoke filled wind tunnel, the aerodynamics and lack of cleanliness would make



# DEB-N-AIR DATA SHEET

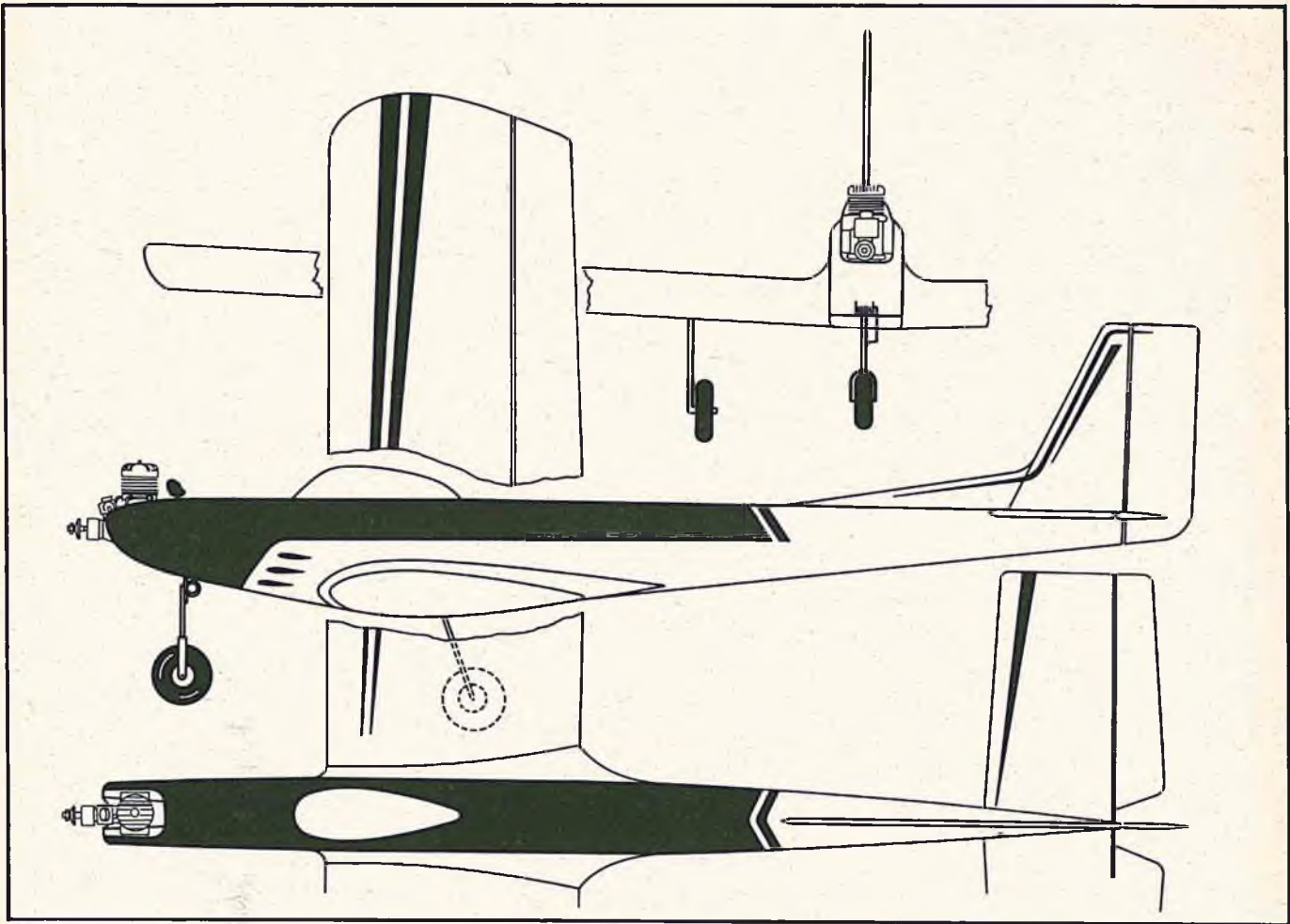

## ENGINE

Use a .56 to .61 R/C engine.

## DIMENSIONS

Wingspan: 68½" Chord: 12"  
Total Wing Area: 800 square inches  
Fuselage Length: 52"  
Max. Fuselage Width: 3½"  
Engine Offset: 3 degrees right  
0 degrees down  
Incidence: 0 degrees wing  
0 degrees stab

## FLIGHT CHARACTERISTICS

Competition Class III or FAI.

## RC EQUIPMENT

Author's prototype used Kraft proportional equipment.  
For "full house" proportional or reeds.

## MATERIAL LIST

Wings:

- (10) ¼" x ¼" x 36"
- (2) 2¼" x 2¼" x 12" tip blocks
- (2) ¾" x ¾" x 6½" maple gear blocks
- (2) ¾" x ¾" x 2¼" maple torque blocks

- (1) 1" x 4" x ¼" plywood
- (1) 6" x 12" x ⅜" plywood
- (16) ⅜" x 4" x 36"
- (1) ¼" x 2" x 12"
- (1) ⅜" x 2" x 36"
- (2) ¼" x 36" triangular stock

Tail Group:

- (2) ¼" x ¼" x 36"
- (2) ¾" x ¼" x 36"
- (1) ¼" x 6" x 36"
- (1) ⅝" x 3" x 36"
- (2) ¼" x 6" x 36"

Fuselage:

- (5) 6" x 12" x ¼" plywood
- (3) ½" x 36" triangular stock
- (2) 1" x 1" x 48"
- (2) ⅜" x 4" x 48"
- (1) ½" x 4" x 48"
- (1) ⅜" x 4" x 36"
- (1) ¼" x 4" x 36"
- (1) ⅜" x 1" x 36"
- (2) 1" x 1¼" x ⅜" maple blocks
- (2) 1" x ⅜" x 12" hardwood motor mounts
- (1) ⅝" x 36" piano wire
- (1) Lakin Nose Gear or equivalent
- (1) pair 3" DuBro wheels
- (1) 2¼" DuBro wheel

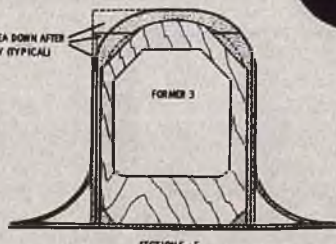
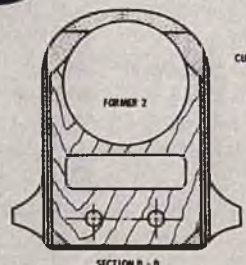
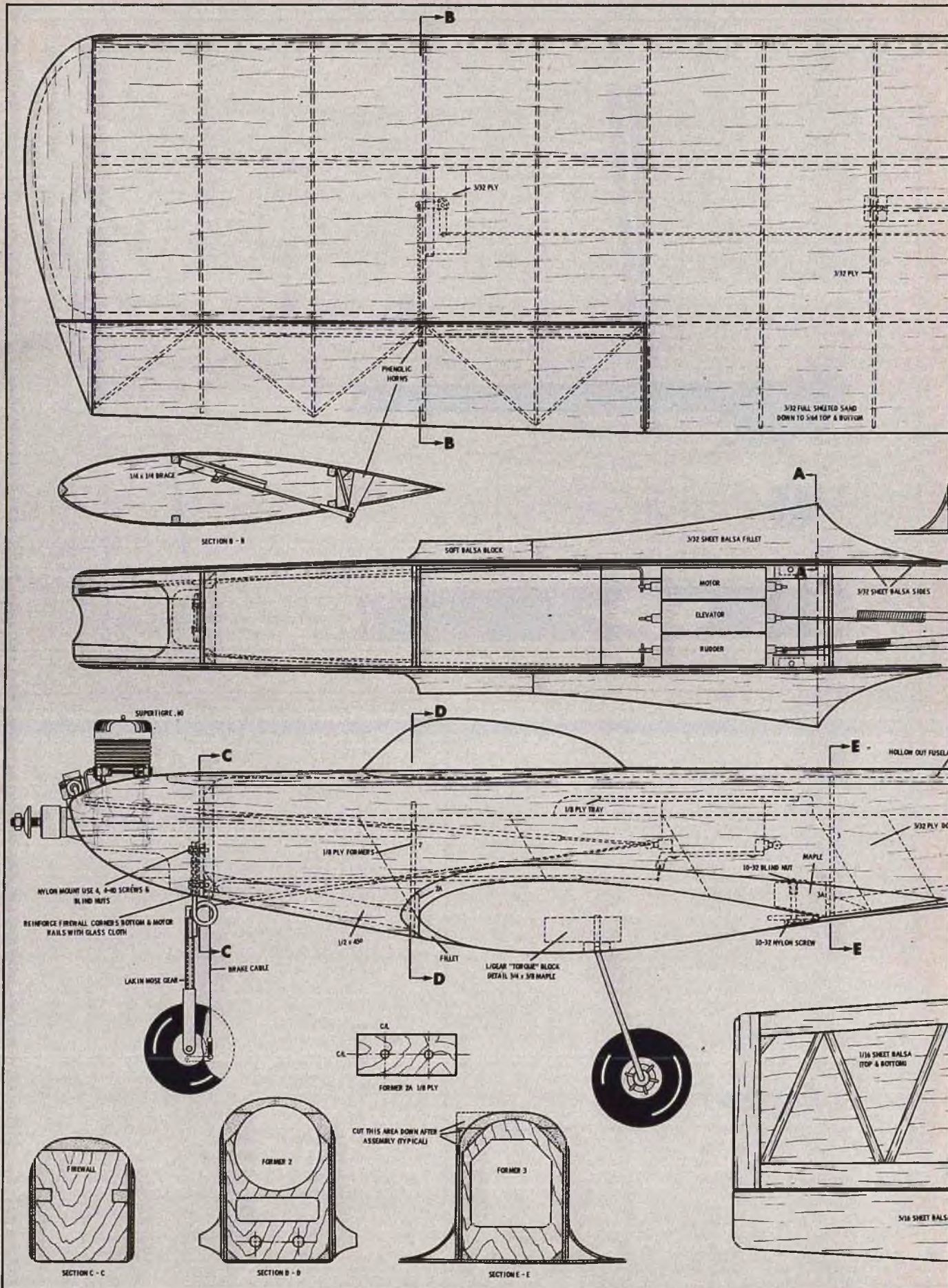

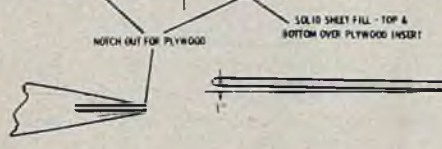
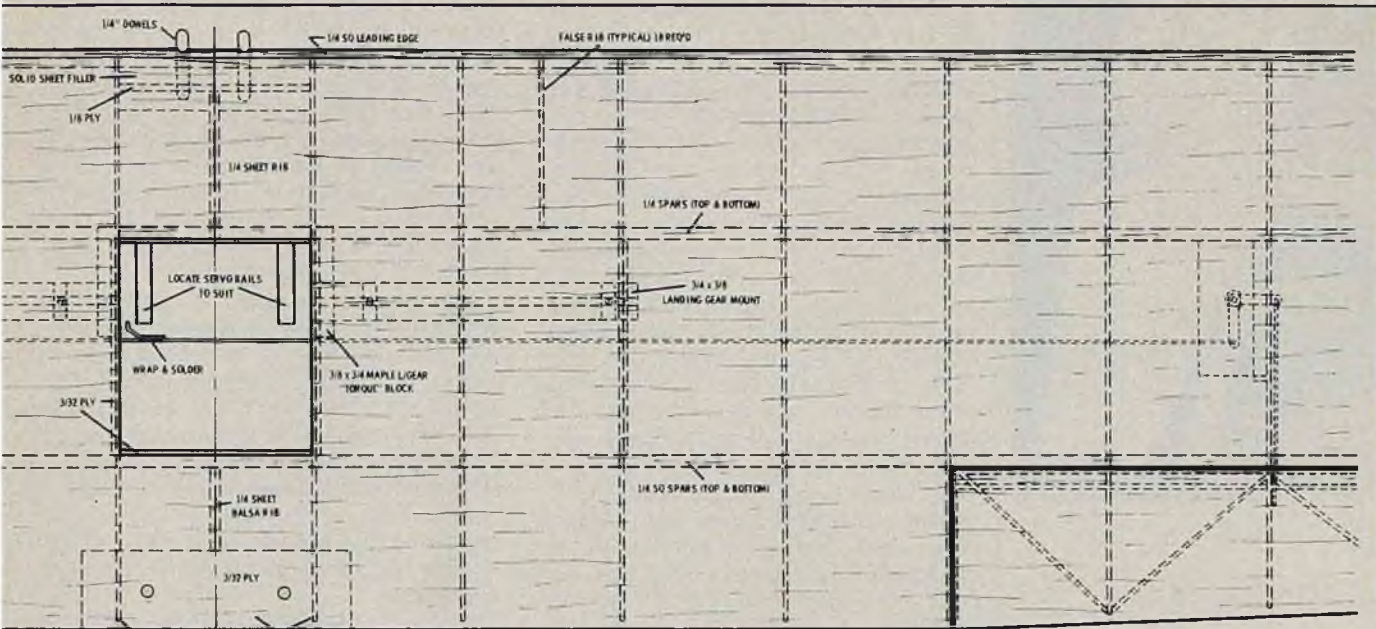

ON RIBS 6, 7, 8, 9, & 10 CUT EACH TRAILING EDGE TIP 1/8\"/>

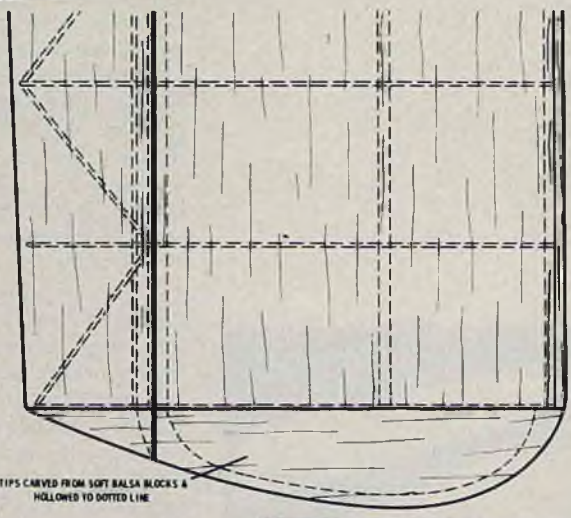
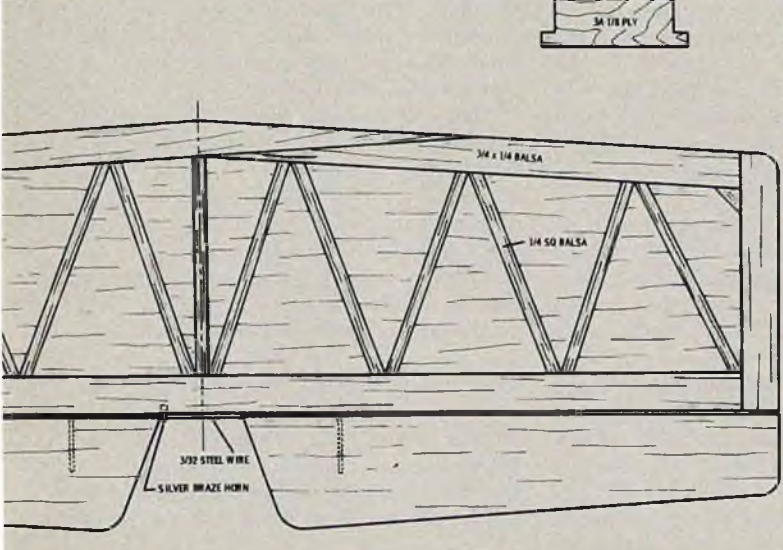
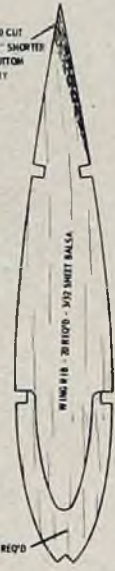
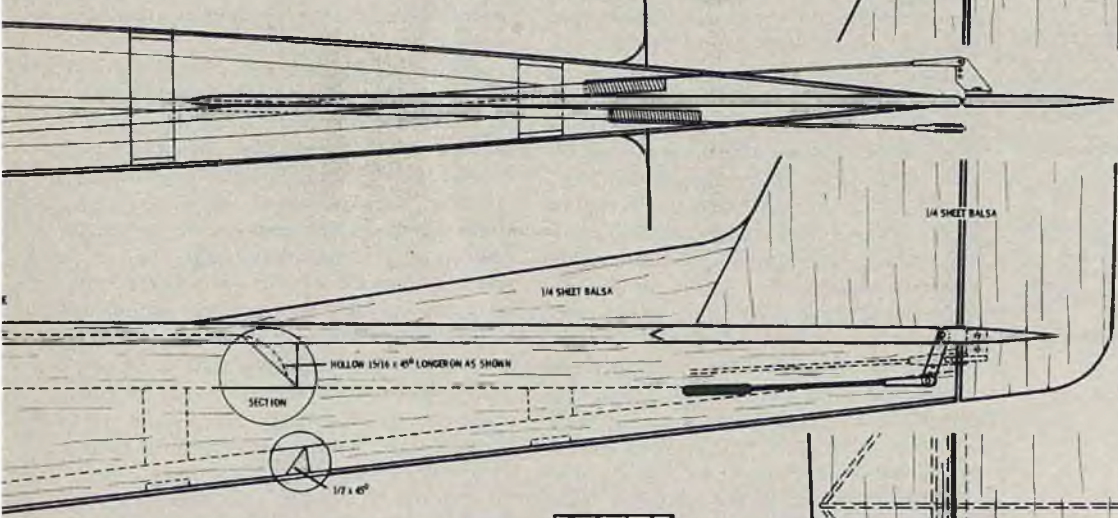

SPECIFICATIONS  
 SPAN - 48 1/2"  
 WING AREA - 800 SQ. IN.  
 ENGINE - 45 TO 60 C.C. IN.  
 PROPELLER - 12-6 OR 11-7  
 WEIGHT - 7 LB.

**RADIO CONTROL modeler MAGAZINE**

**DEB-N-AIR**

DESIGNED BY **BRYAN LAXIN** DRAWN BY **C. FLORES**



*A symmetrical wing,  
clean lines, full  
fairings and fillets,  
as well as a  
unique control  
surface attachment  
add up to an  
aerodynamically  
clean design . . .*

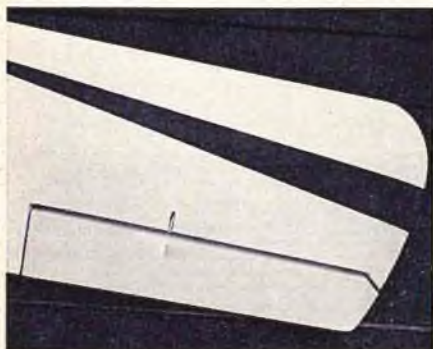

us sick.

The first kind of turbulence we can do very little about. The second kind, that created by our airplane, is turbulence we can, to a degree, control. Turbulence is first kicked up by the fairings and cowlings around the prop and engine. The next place for old man turbulence is around the front of the wing near the fuselage. Turbulence here and around the canopy can start vertical air stirring which can ultimately affect the tail empennage. Carrying on to the rear surfaces of the wing near the fuselage, enough air drag can be created here to spoil the lift in the innermost  $\frac{1}{2}$  section of the entire wing under certain conditions, unless generous and proper wing fillets are provided. Ah Ha, — you always thought those beautiful fillets on real airplanes were just for looks didn't you? Well I kid you not, all the old successful designers of full scale aircraft continually pound on two primary requisites. If all else fails to provide stability, keep the rudder & fin large and keep all turbulence to a minimum by generous use of fillets and fairings. Air stirred up around the wing can keep the tail surfaces in constant turbulence causing no end to sloppy control response fish-tailing and many other problems in various attitudes of flight.

The Deb-N-Air is extremely stable in fairly rough air. She owes this quality to her symmetrical wing and to her clean lines, include full fairings and fillets. One other thing should be mentioned while on the subject of turbulence. Take a look at Deb-N-Airs' control surface attachment and fairing. No — take a **close** look . . . To our knowledge no other R/C design today, utilizes the principle used in the Deb-N-Air. You'll notice that the trailing edges of the stab and vertical fin (near the hinge-line) are finished nearly full thickness and are square. In other words, there is no taper or round edge as is customary on all R/C designs. The leading edges of the movable controls (rudder and elevator) are also full thickness and have sharp corners. The leading edges are shaped to a flat "V", being tapered from about  $\frac{1}{16}$ " back of the hinge-line into the point of the "V." Metal or nylon hinges are then mounted right in this pointed area of the control surface. The other half of the hinge is centered in the square trailing edge of the stabilizers. You will see that this causes the control surface to blend in perfectly aerodynamically with the stab and fin. This effectively avoids the usual turbulence caused by rounding the rear edges of the stabilizers and the front edges of the movable control surfaces. Careful fitting also causes the crack to shut up tight when the elevator or rudder is thrown to full position, and eliminates spoilage or leakage at the hingeline.

This system of fairing and hinging comes as close to a completely sealed hingeline as possible on a model. This is considered so important for full-scale aircraft that they have actually provided them with a pocket and rubber seal arrangement along the control hingeline. Again, let me stress this tight fit and seal is not only for appearance but is important for the elimination of turbulence and sloppy control response at the control surface.

The Ailerons are fitted in much the same manner. Keep them smooth and keep the opening on the bottom as small as possible. Only enough for clearance. On the Deb-N-Air, when one aileron goes full down, it shuts up tight. No air leakage and no turbulence. Fairing the bottom of the wing into the fuse is important, too. This is the final touch, eliminating the turbulence rolling up from the bottom of the frontal cowl and wing pocket.

Finally, the moments were figured to provide as much stability as possible in the rolling and looping maneuvers. The best arrangement we could provide was 22% nose movement and 48% tail movement. These percentages are based on wing span. Both are unusually long but are considered ideal for our application.

As for the questionable trend in some areas to swept wings, it's an established fact, aerodynamically speaking, that there is no measurable advantage in swept back wing below supersonic speeds. Every degree of sweepback spoils precious lift and encourages tip stalling at a tremendous rate. No reasonable amount of sweepback in the wing can provide the stability found in a little larger vertical stabilizer. There is a very small drag advantage in swept wings for speed aircraft even below sonic speeds. However, this is not applicable to R/C since we definitely want some drag to control diving speed and the wing is where we want the drag to develop. The Deb-N-Air sports a conventional straight wing which is the most efficient wing available from an aerodynamic standpoint.

One other point worthy of mention before we delve into construction details is the landing gear. The main gear is mounted almost on the C/G but has a good deal of back sweep to provide an extra softness. The nose gear is of special design using  $\frac{1}{8}$ " wire torsion springs and an adjustable shock absorber. The symmetrical design helps maintain perfect alignment and eliminates continuous re-adjustment. The steering arm is so positioned as to provide no load on the servo even when the gear is flexed back at a severe angle, and since the flex is always in line with the fuse the servo gets very little pull on hard

*(Continued on Page 82)*

# EASY TWIN

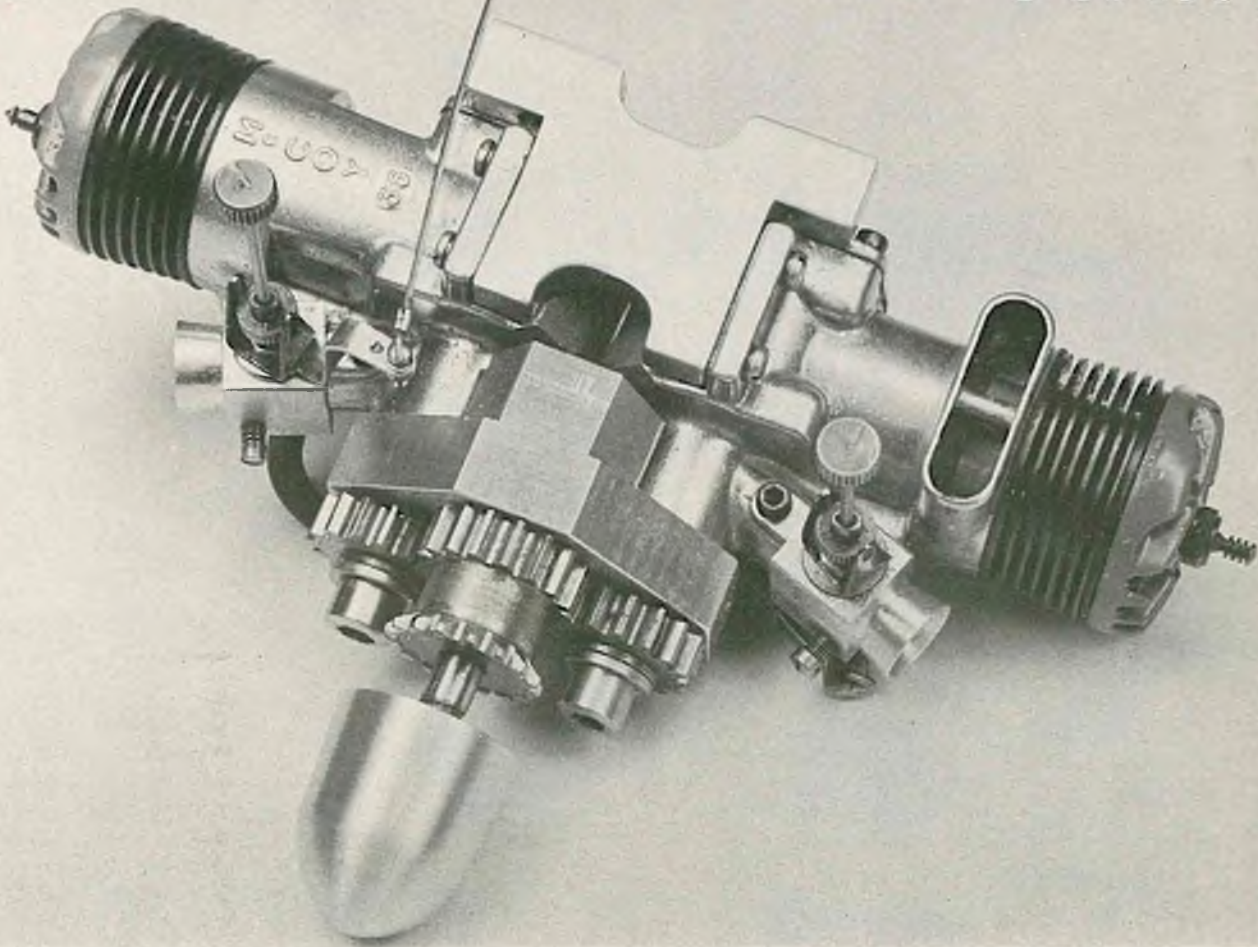

Eliminate vibration problems and step up performance with this easy-to-duplicate twin engine configuration by Walt Watkins.

**A**S pointed out, quite graphically, in a recent article by Dr. Walt Good, the advantages of an opposed twin cylinder engine offers quite a bit from the standpoint of vibration alone. To date, little commercial progress has been made along these lines.

From the do-it-yourself standpoint, the fabrication of a true opposed twin involves quite a bit in the machining of crankcases, split connecting rods, etc. The method that I have used with a good deal of success may be of interest to you.

You will note from the photographs two McCoy 35's geared to one prop shaft in the form of a twin. If these are timed to fire together, they cancel out vibration like a true twin. In addition to being much easier to construct, there are other benefits. The cylinders and exhausts are out in the slip stream since the engine is a little

wider, thus adequate cooling with less fuel deposits on the firewall area. The engine is shorter, front to back, no offset cylinders, and it can be geared to turn scale-size props. Those RC'ers with 9 foot Taylorcrafts can now use 18" props. The small increase in weight seems to be another benefit, since many ships seem to come out tail heavy with the smaller battery complement used in today's proportional systems. The Senior Falcon shown in the photographs balanced exactly right with the twin installed.

On the other side of the ledger, there are some drawbacks. One of these is the fact that there are two carburetors with two needle valves. Once the initial adjustments are made, however, it ceases to be a problem. Another disadvantage is that unless you know of a source of "left hand" props, you need "left hand" motors. In order to obtain these, you

need new crankshafts. K&B Manufacturing makes them for their motors and other manufacturers may be able to provide them for their mills. I fabricated my own for the McCoy's by brazing three pieces together, similar to the old McCoy 60's.

Some may wonder about the two carburetors. I tried using one with manifolding, but the fuel mixture needed seems to vary from motor to motor with the result that one would run lean and the other rich.

I used a gear ratio of one-to-one turning a 12/6 prop. Using a larger prop will necessitate a larger center gear over the engine gears to keep the motor RPM's up. The gears are oiled by the oil blown by the crankshafts.

The front of the crankcases were lathe turned on a stub arbor to press fit in  $\frac{5}{8}$ " reamed holes in the prop shaft support. The reamed holes are spaced



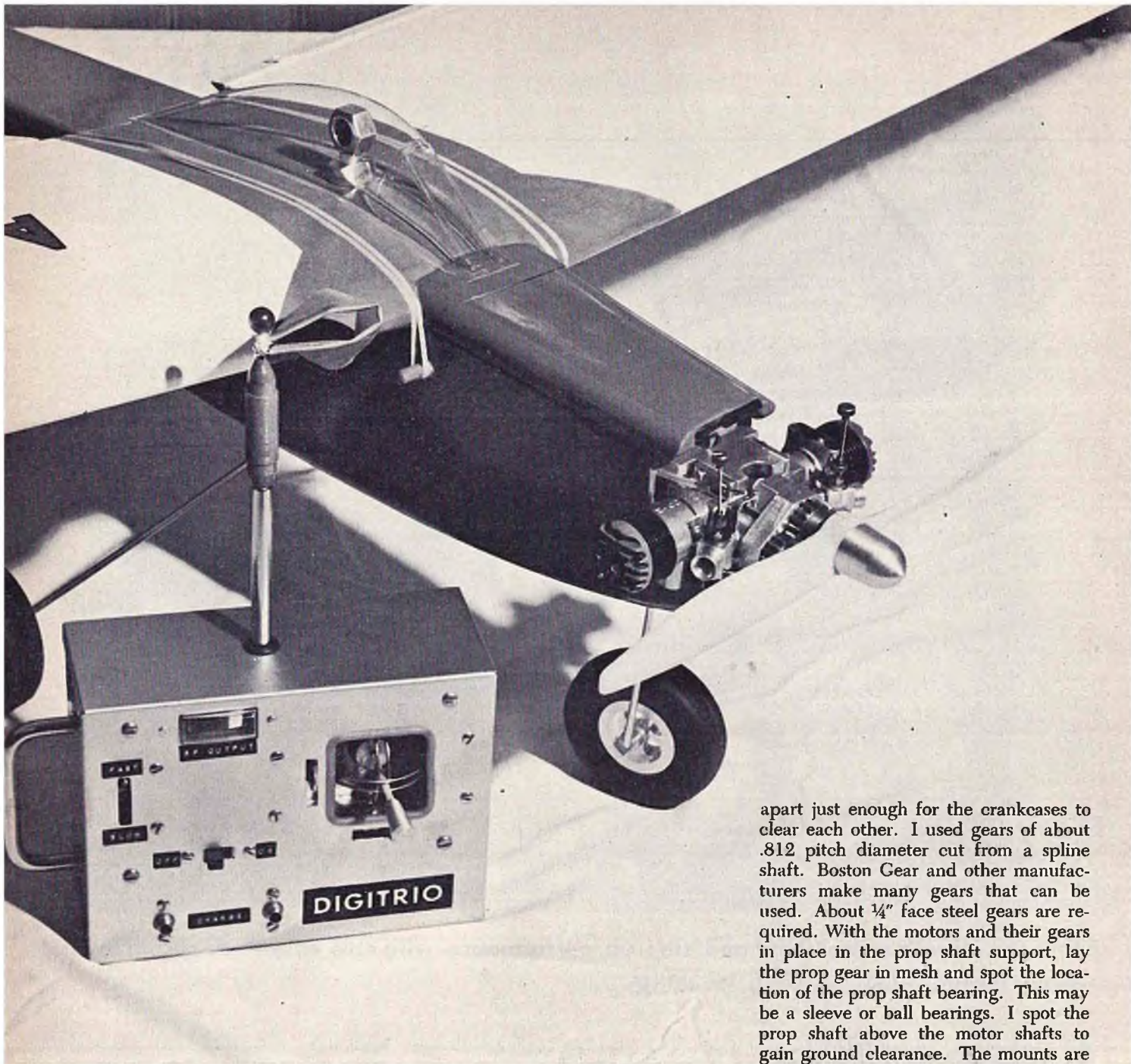

apart just enough for the crankcases to clear each other. I used gears of about .812 pitch diameter cut from a spline shaft. Boston Gear and other manufacturers make many gears that can be used. About  $\frac{1}{4}$ " face steel gears are required. With the motors and their gears in place in the prop shaft support, lay the prop gear in mesh and spot the location of the prop shaft bearing. This may be a sleeve or ball bearings. I spot the prop shaft above the motor shafts to gain ground clearance. The mounts are now made to suit. The connection of the two carburetors is shown in the picture. The prop shaft support is made of aluminum and can be hack sawn and filed to shape.

As this idea can be used with different makes and sizes of motors, no drawings are given. I have used Cox .049 Golden Bee's in this fashion with good success. These motors will run in either direction.

I call my .70 twin "Thunder Ball" after the sound it makes—loud! Also shown in the photographs is my Digitrio transmitter. The stick is an arrangement similar to Min-X but made from music wire. The board track was milled out on a milling machine. To date, eight of the RCM Digitrios are being constructed in our group, the Monmouth Model Airplane Club—complete with what we call "Digitrio Get-Togethers."

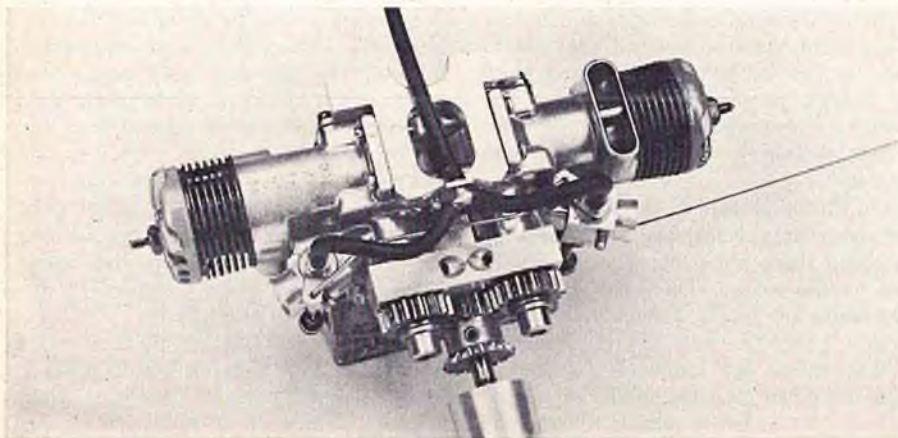

STANLEY J. BROWN

ADDING  
FLEXIBILITY  
TO THE  
PHELPS  
PULSER

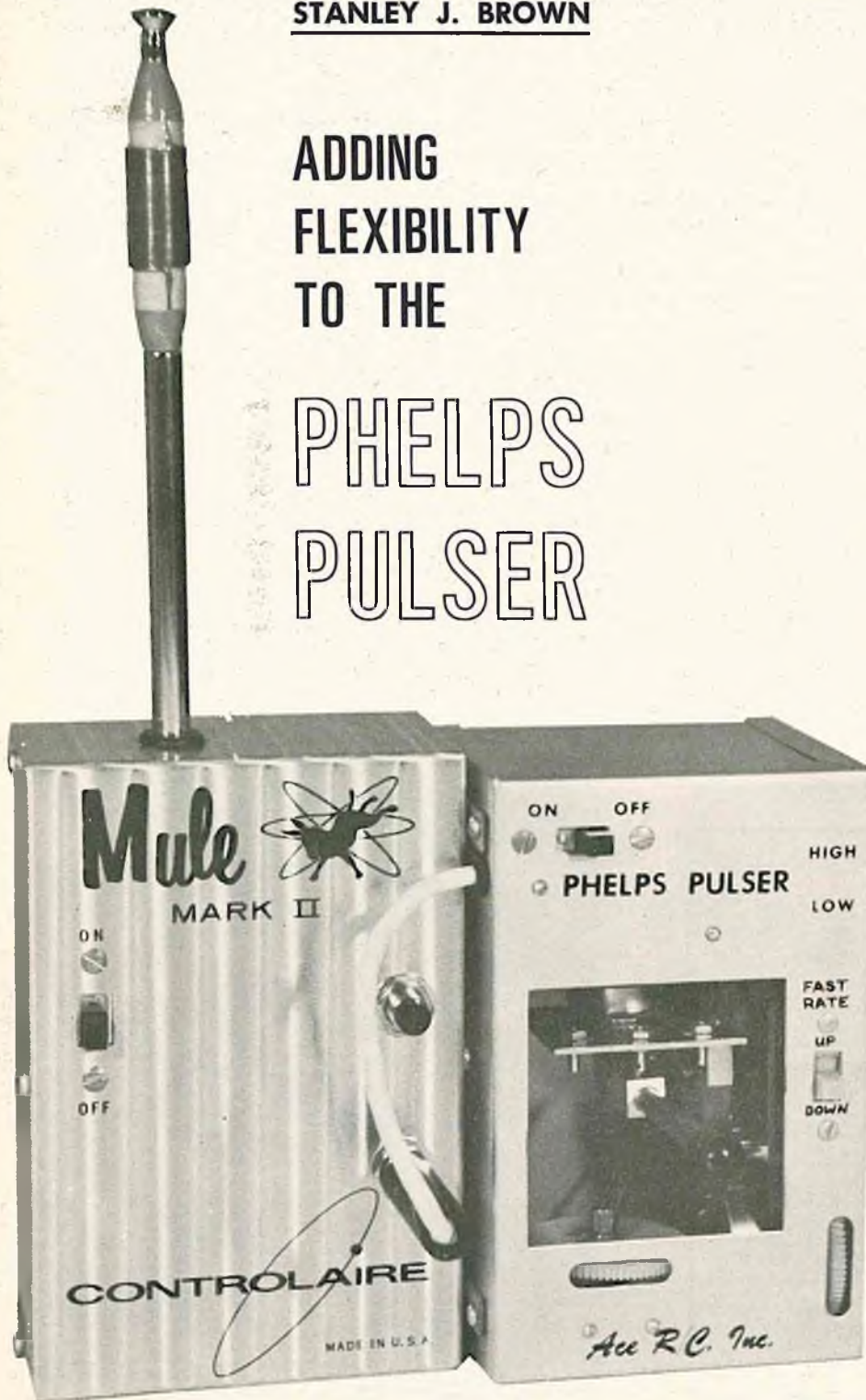

**T**HE introduction of the Adam's magnetic actuator and the comparatively low cost of single channel radio gear led many modelers in this area to take the "poor man's" approach to proportional R/C. Several of our crowd built little .020 and .049 powered models and flew them quite successfully on pulse-proportional rudder. There has even been some successful use of the Adam's actuator for Galloping Ghost applications in .020 powered models. Many of us chose the Phelps Pulser because of the wide range of pulse rates available. This pulser operates equally well at the low pulse rates of 3 to 12cps needed for motor-powered pulse-proportional actuators, and at the faster rates, up to 30 cps, required by the quick acting magnetic actuators. A desire to go on to higher powered models and to include motor control with a separate actuator resulted in this article.

In the Galloping Ghost system, if a separate actuator, servo, or escapement is used for motor control and for fail-safe, the rudder-elevator actuator stops pulsing during the motor speed control function. Usually, the actuator is spring loaded to return to neutral rudder, simultaneously producing full elevator deflection, usually down elevator. Now, if an extreme elevator deflection must be endured during engine speed changes, and especially for a fail-safe function, it would almost always be preferable that this be up elevator rather than down. Therefore, the linkage connecting the actuator, rudder and elevator must be setup to give up elevator with neutral rudder. With this arrangement, up elevator will be produced by a fast pulse rate, so the pulser must be setup to increase the pulse rate when up elevator is desired. Most pulsers, and particularly the Phelps Pulser are set up just the opposite; increasing pulse rate corresponding to down elevator. One way to change this relationship on the Phelps Pulser is to reverse the wiring to the outside terminals of both rate pots, stick and trim, and by rotating the neutral position of the stick pot shaft 180 degrees clockwise, looking at the end of the shaft. The reason for this last part will become obvious later.

This writer wanted a more flexible system which would operate either way; fast pulse up, or fast pulse down. With this flexibility any pulse-proportional model can be flown. Modifying the Phelps Pulser to achieve this flexibility of function turned out to be somewhat more involved than just the simple reversal described above.

Before we get all tangled up in the wiring, let's be sure the pulser is operating correctly. The Phelps Pulser, as supplied in kit form by Ace R/C, substitutes 10K pots for the 5K rate trim pot and the 25K width trim pot compared to the Phelps circuit published in

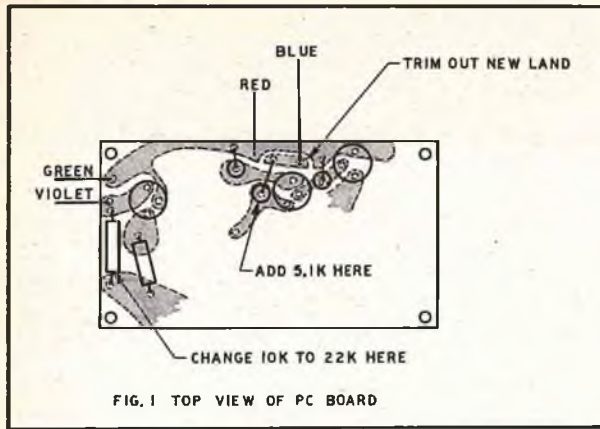

Above: Modifications to Phelps Pulser board. Right: The modified schematic.

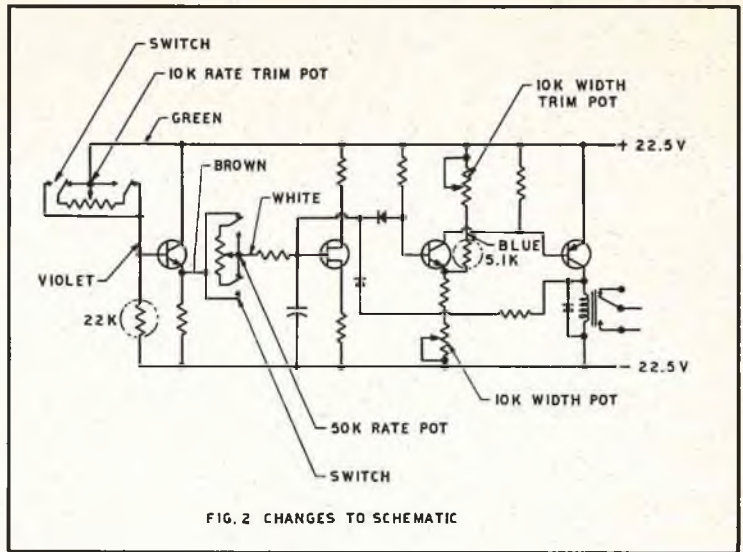

Grid Leaks, March-April, 1964. No other changes were made. As a result, apparently, of these changes you could completely stop my kit pulser with either trim pot. One friend of mine built a Phelps Pulser from the Grid Leaks circuit and has had no trouble. Another built his from an Ace kit as I did and had the same problem just described. One cure for this problem is obvious — replace the pots. A cheaper cure is shown in Figures 1 and 2. Replace one 10K resistor with a 22K resistor and add a 5.1K resistor in series with the width trim pot as indicated by the circled components in Figure 2. You can put the 5.1K resistor in series with the blue lead to the width trim pot at either end, or you can install it on the printed circuit board as I did. Figure 1 shows where to trim out a new land on the PC board (I used the edge

of a small file) and how to install the resistor and blue lead. It may also be necessary to experiment with different neutral positions of the rudder stick pot to obtain the best width variation.

Now, on with the rate reversing scheme. The immediately obvious part of this task is to put in a switch which will reverse the wiring of both rate pots. A 4-pole double throw switch available from either Ace or World Engines does the job nicely. Figures 2 and 3 show the wiring of the switch and pots. But, this is not enough. If we stop here, we will get the normal pulse rates in the fast-pulse-down position, but an agonizingly slow rate in the fast-pulse-up position. This is because the Phelps Pulser uses only the last 80 degrees of a 270-degree, 50K pot on the elevator stick to give a wide resistance (rate) change: zero resistance in the full down elevator

position, 7.4K at neutral and 14.8K in full up position. If you just reverse the wiring of the pot, you now get about 35.2K at full up, 42.6K at neutral and 50K at full down. Since increasing the resistance in this circuit slows down the pulse rate, you can see what happens to the pulse rate with a simple reversal of the pot leads. What we have to do is to keep the 0 to 15K resistance change, but also to balance it so that the net resistance at neutral is the same regardless of which way we throw the selector switch. Simply centering the pot shaft with the stick at neutral will balance the system, but the net resistance is too high, giving a **slow** pulse rate. Substituting a lower resistance pot would step up the pulse rate, but reduce the degree of change available. My next

(Continued on Page 64)

Below: Pot wiring diagram. Right: Disassembled pot showing painted areas.

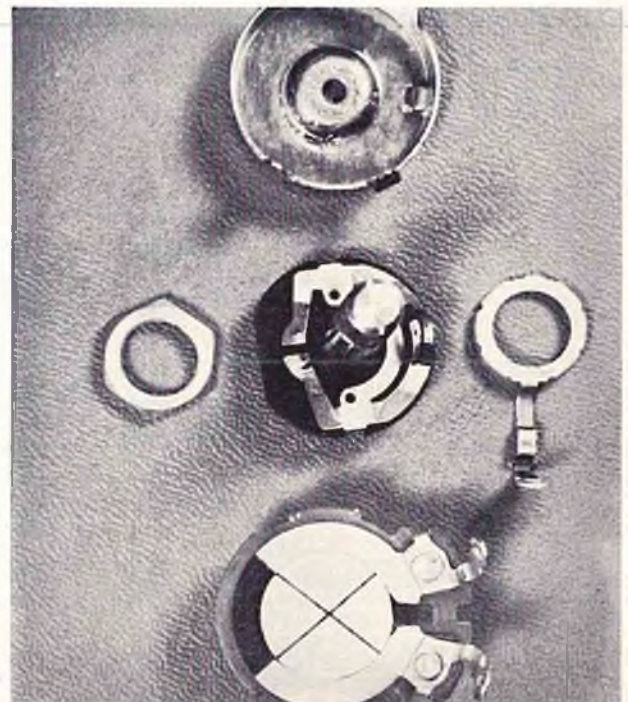
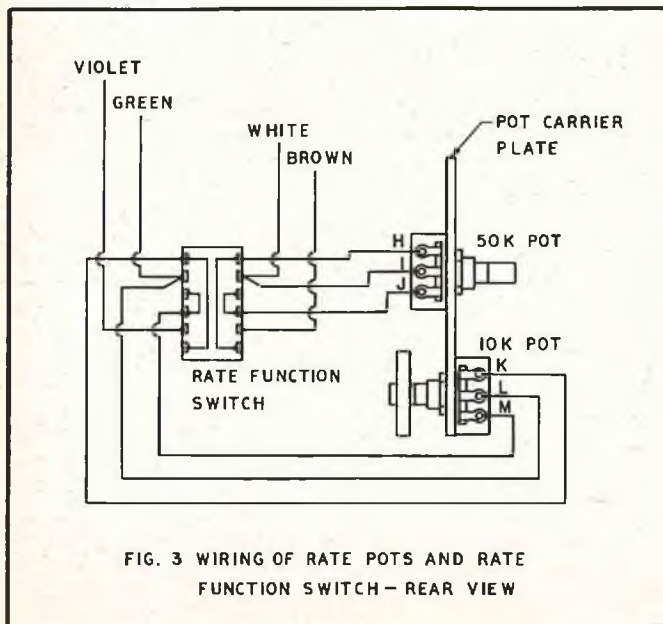

**Before you fly is the time to make those all-important safety checks. In this installment, Lou provides a pair of checklists that may save your next ship.**

# R/C FLYING SAFETY

**PART III**

**by CDR. LOU GUERRIERI, U.S.N.**

As has been noted in Parts I and II, the Navy approach to aviation safety appears to be a natural for reducing RC crashes. Knowledge of what causes the RC model to be consigned to the scrap barrel is the most important part of the program. Education IS safety. Having an awareness of the two major RC crash causes – Personal Error and System Failure – is a great stride forward in promoting the ultimate goal: fewer RC accidents.

Since System Failure appears to be involved in a relatively small proportion of crashes, any approach to saving our models should concentrate on the Personal Error aspects of pre-flight and in-flight operations.

For a positive guide to the proper steps to take once the model is ready for flight let us once again look to Navy procedures. Before a Naval Aircraft is inspected for over-all airworthiness and before every major aircraft evolution (starting engines, taxiing, takeoff, cruise, and landing) a detailed, written check list is used by the Aviation Machinist Mates and Naval Aviators involved. Modern aircraft are so complex and contain so many controls and switches that it is sheer folly to rely on memory to position correctly each and every one. The check list ensures that every control, every dial, every switch, every valve is inspected, posi-

tioned, and ready. The frailties of human memory are eliminated and safer operations result.

A check list can do much the same thing for us. If you have been flying any length of time you probably use some sort of a check list right now. That one stored away in the brain serves very well, until you forget something. A written check list is designed to eliminate this problem. Here is a check list that can be expanded, reduced, or modified as you see fit. If it prevents even one crash it will have served its purpose.

## DAY-BEFORE-FLIGHT CHECK LIST

1. Charge transmitter and receiver batteries . . . .
2. Check essential equipment and supplies:
  - Field box . . . .
  - Fuel . . . .
  - Fuel pump/bulb . . . .
  - Propeller . . . .
  - Glow plugs . . . .
  - Starting battery and clips . . . .
  - Screwdrivers, as necessary . . . .
  - Wrenches including prop nut and glow plug . . . .
  - Spare parts (fuel tubing, engine bolts, wheel retainers, tape, pins, etc.) . . . .

- Wiping rags . . . .
- Rubber bands . . . .
- Repair kit . . . .
- First aid kit . . . .
- 3. Security Check:
  - Inspect all surface hinges . . . .
  - Inspect all mechanical linkages . . . .
  - Check servo mounting bolts . . . .
  - Check general condition servos . . . .
  - Check wiring harness, plugs, sockets . . . .
  - Check general condition receiver and antenna . . . .
  - Check engine mounting bolts . . . .
  - Check engine throttle and set screws . . . .
  - Check fuel tank and tubing . . . .
  - Check battery pack and holddowns . . . .
  - Check wheel alignment, freedom of movement . . . .
  - Check wheel retainers . . . .
  - Check landing gear struts and holddowns . . . .
  - Check nose wheel, strut, and steering . . . .
  - Inspect model for nicks, bruises, holes, fuel soaking, weak bulkheads, torn skin, structural cracks, mating of surfaces . . . .
  - Check general condition . . . .

**Calculate the actual cost of your present ship. Add to this the number of hours it took to construct, and then use these checklists every time you fly . . .**

transmitter and antenna . . . .

**DAY OF FLIGHT CHECK LIST**

1. Predeparture Check:
  - Check proper mating battery/receiver/servo connectors . . . .
  - Make preliminary low power distance check Surface movement (amount/direction) . . . .
  - Simultaneous operation . . . .
2. Car Loading Check:
  - Fuselage and all hatches . . . .
  - Wing(s) . . . .
  - Horizontal stabilizer (if detachable) . . . .
  - Landing gear (if detachable) . . . .
  - Field box with equipment and supplies . . . .
  - Transmitter and antenna . . . .
  - Personal items (sunglasses, lucky hat, chair, cigarettes, coffee, etc.) . . . .
3. On the Field Check:
  - Attach landing gear and horizontal stabilizer (if necessary) . . . .
  - Hookup aileron servo . . . .
  - Attach wing; check alignment/snugness . . . .
  - Check for other operators on your freq. . . . .
  - Conduct range check as necessary . . . .
  - Check movement surfaces and simultaneous

- Hold Left Aileron check Up/Dn Elevator . . . .
  - Hold Right Aileron check Up/Dn Elevator . . . .
  - Hold Down Elevator check Right/Left Rud . . . .
  - Hold Up Elevator check Right/Left Rud . . . .
  - Check Elevator Trim movement . . . .
  - Check Throttle movement . . . .
  - Switch off receiver and transmitter . . . .
4. Pre-Start and Taxi Check:
    - Fill fuel tank . . . .
    - Check for other operators on your freq. . . . .
    - Switch on receiver and transmitter . . . .
    - Select full open throttle . . . .
    - Switch off receiver and transmitter . . . .
    - Start engine . . . .
    - Switch on receiver and transmitter . . . .
    - Select Low Engine, then set for fast idle . . . .
    - Extend transmitter antenna . . . .
    - Check surface movement and simultaneous
      - Hold Left Aileron (left aileron must be up) check Up/Dn Elevator . . . .
      - Hold Right Aileron (right aileron must be up) check Up/Dn Elevator . . . .
      - Hold Down Elevator check Right/Left Rud . . . .

- Hold Up Elevator check Right/Left Rud . . . .
- Check Elevator Trim full throw Up/Down . . . .
- Ensure taxi path is clear . . . .
- Start taxi and check brakes . . . .
- Check extension of transmitter antenna . . . .
- Taxi for takeoff . . . .
- Set Elevator Trim for takeoff . . . .

Close examination of these check lists should reveal that most of the Personal Error Before Flight crash causes mentioned in Part I, and a few of the System Failure causes from Part II, have been anticipated, if not eliminated.

If you use these check lists and don't have a crash they have helped save the model for yet another session. But you won't know it right away. It should become apparent, however, when you find that you have fewer and fewer mishaps during the course of a flying season. The crash that brings awareness is the crash that happens, not the crash that was avoided.

It is my opinion that most of us look for more flying and less building. The model advertisements of the past year should be proof enough. Achievement of this goal from the safety approach has been the purpose of this series of articles. Comments concerning the "fly safe - save the plane" philosophy are invited.

Happy Landings—one per approach.

# LOW-WING TAURI

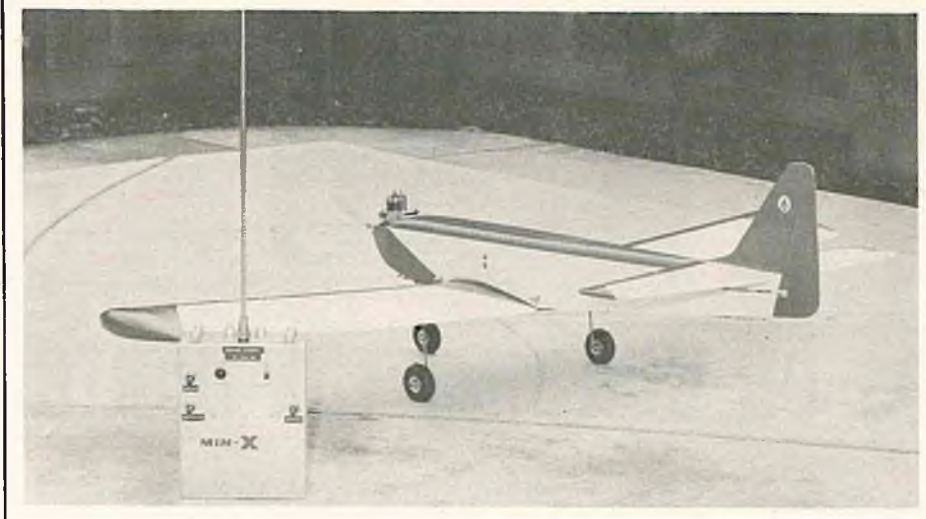

Tired of that six-foot monster? Try this face-lifting technique for an old standard.

BY GEORGE LOWDER

**I**N the February '66 issue of RCM Ken Willard devoted his "Sunday Flier" column to *The Small Multi for Small Pocketbooks*. A large portion of this fine article consisted of a letter from Sherwood Heggen of Bricelyn, Minnesota in which he expressed his views on the subject and summed up with this statement — "This is what I would like to see: Four foot wing span, low wing, 10 channel, trike gear, zero trim, dihedral which is meant exclusively for an aileron ship, and engine size from .19 up to .35. What would be wrong with this?"

My low wing Tauri fills the bill almost to the letter. I have taken Ed Kazmirski's Tauri plans and after building and flying two beautifully performing shoulder wing models, modified them to produce a low wing Tauri.

The standard Tauri construction was used throughout with the exception of the modifications required to reposition the wing saddle at the bottom of the fuselage and the stabilizer on the top. The wing and stabilizer positions relative to the fuselage length were maintained but it was later found necessary to remove the positive wing incidence of the "standard" Tauri in order to keep the ship within a half mile of the ground. The zero-zero setting solved this nicely.

The other major change consisted of removing half the dihedral in the wing, the installation of strip ailerons, and

main gear mounting blocks.

The entire model was silked and doped and painted white with red trim which produced a little beauty weighing in at four and one half pounds. (Four pounds isn't unrealistic — I build "strong".)

An O.S. Max .35 with a 10-6 nylon prop provided ample power for handling *all* maneuvers with ease.

Since I placed myself neatly in the middle of the "Sunday flier" category with a limited pocketbook, my multi equipment consists of a six channel Min-X superhet, relayless, non-simultaneous transmitter and receiver. This combination together with four Annco servos and a 500 nicad battery pack was installed in the model. The Annco servos are almost lost in the huge radio compartment provided by this design, so you fellows who like lots of "finger room" will like this arrangement.

The finished model balanced about one half inch forward of the indicated C.G. I decided to leave it there which proved to be quite satisfactory.

You are probably wondering what I am doing with four servos and only six channels so I had better explain. Our club flies off a dirt field which makes trike gear very desirable; therefore, I wanted to keep the steerable nose gear, but I also wanted ailerons.

To do all this with one rudder servo produced a linkage problem second to none, so I did the next best thing. I

installed an aileron servo in the wing with the standard strip aileron linkage and disconnect plug. This servo was wired in parallel with the rudder/nose wheel servo so that both servos were driven simultaneously by the rudder reeds. The results were a smooth operating coupled rudder/aileron system which eliminates any alignment problems each time the wing is removed since the coupling is electrical, not mechanical.

I'm sure this is nothing new but to any of you who haven't tried it and want to, it works beautifully. The results provided by the fourth servo is well worth the extra weight.

For those with 10 channel gear the problem is much simpler, but I don't think you will have any more fun with it than I do with my "mickey mouse" hook up.

A second low wing Tauri with German fighter plane markings (very impressive) made its appearance at our field last Sunday and created a lot of excitement and interest so I'm sure we are going to see more of them — fact is I have secretly started my second one — but don't tell my wife!

This little multi is a real performer and will give the "Sunday flier" all the thrills (and chills) he wants without having to build and support a fuel gulping six footer. Try it. I think you will like it. □



---

## TIPS ON BUILDING THE DIGITRIO

---

A "reader's report" on building the RCM Digitrio. By Frank Baker as published in the "Marcs Sparks."

I HAVE just completed building the Digitrio digital proportional system which has been appearing in Radio Control Modeler, and would like to pass on my experiences. First, I would like to congratulate Mr. Ed Thompson on a superb job on a complex task. The whole system was well conceived and executed with great care. The proof reading of the schematics and text was such that the usual errors which drive the non-sophisticated builder to despair were not present. Don Dewey of RCM is also to be congratulated for his courage in putting the reputation of his magazine on the line. If Digitrio was a "dud" many thousands of disenchanted readers would blame RCM and sales could have been hurt.

The history of my Digitrio project will be presented in chronological order essentially as it happened as I believe the various problems will be put in their proper context. I must warn the reader that one hundred percent of all the problems were generated by this builder and not the system. However, I'm sure other builders can make the same or similar problems arise.

The transmitter proved to be extremely easy to obtain parts for and its construction was straightforward. I used a Bud 8 x 6 x 3½ mini box for the case which I trimmed to about 3 inches in depth. I felt the original box did not allow for any alternative in power supply and 8 nicads cost a lot, hence the larger box. The motor control pot was moved to the right hand side so that as I cradled the transmitter in my left arm, the motor control could be moved with the index finger. One must be very careful in installing the Bonner stick

assembly and the trim pots as there is not a lot of room. When first turned on, the transmitter seemed to be all right. The wave forms looked as they should except the movement of the control stick would cause the middle pulse to disappear behind the outer pulses. A check of the output was very disappointing. The Digitrio put out about 1/5th as much as my Controilaire Mule II. I borrowed a grid-dip meter and started checking. Much to my horror I discovered that the transmitter was radiating on 19 MC with a 27.145 crystal. I tried varying the resistors to the crystal to change its drive, but to no avail. A ham friend of mine convinced me that the frequency determining element was L-2. I started peeling of turns and finally at 8 turns the frequency returned to 27.145 and the output exceeded that of the Mule. Lesson number one: do not substitute parts!! I could not find a CTC 2713-3 9/32 dia-coil form so I substituted a ¼ inch receiver coil form which I had. The proper solution was to order one and wait for it. The man hours lost would have been worth the postage. I made one innovation in the transmitter which really helped. I added a half piece of #18 solid wire at the left end of L-4 to serve as an oscilloscope connection; it will prove invaluable in check out.

Construction of the receiver is similar to a normal receiver and no serious problems were encountered other than in the acquisition of parts. In that, I was ordering parts from ordinary radio supply and surplus houses, not all the parts were physically equivalent. I never did find a source for RMC capacitors when I needed it, though I have since

found one. Because of the physical space problem, I found it simpler to start at the left hand side of the PC board, putting in all components at once; then work across the board to the right. A number of parts were a tight squeeze, but they all made it. It should be mentioned that I made my own PC board by laying a PC board under the magazine page, hitting each drill hole with a sharp nail, then connecting the indents with dope on a one-hair brush. The tune-up procedures in the article were followed and the receiver worked perfectly the first time. About 6 weeks after finishing the receiver, it suddenly refused to operate. I checked the voltage and obtained full battery voltage at all transistor bases except Q-7 and Q-6. The first thought was that of a major short which blew the transistors, so I pulled Q-4 and Q-3, but both were all right. After much checking, I found that the PC board had cracked right next to where the transformer frame forms the jumper for the positive voltage for Q1-5. In retrospect, what happened was that I had beveled the edges of the PC board and in doing so reduced the land to about ¼", and in the process, must have cracked it. A short piece of wire replaced the land. Lesson number 2: The natural tendency is to blame electronic components for failure, but don't fall into this trap. It is virtually impossible to remove a component from the receiver without doing damage to it or its neighbors. Unless you are really "ham handed" with a hot iron, 99.9% of all failures are mechanical in nature! One good way of finding them, espe-

(Continued on Page 53)



# REGATTA

The Sidewinder — fastest R/C boat in the world! A new world's record of 49.3421 MPH set by owner-builder Steve Stevens on February 26, 1966.

## SIDEWINDER SETS WORLD RECORD AT 49.34 MPH!

West Coast design sets all-time absolute speed record for R/C boats.

**T**HE San Diego Argonauts 6th Annual Mid-Winter Regatta, held February 26th and 27th, was highlighted by the shattering of **seven** world speed records on the first day of the two-day event! The high point of the meet was the new all-time absolute speed record for R/C boats set by Lewis A. "Steve" Stevens of Los Angeles. Steve, a member of the Modeleers Club of Venice, and one of the real "old-timers" of model boating, ran his original design hydro, the Sidewinder, to a record run of 49.34 MPH! This boat is one that actually has to be



seen to be appreciated. The overall workmanship, design, machine work, meticulous detail, metallic maroon paint job, etc. cannot really be shown in the accompanying photographs. In fact, many of the spectators, and even a few of the contestants, thought the Sidewinder was strictly a "show" boat — but then, they don't know Steve Stevens!

During Saturday morning, while high winds and light rain prevailed, the Sidewinder was, perhaps, a "show" boat for all of us to see and admire. After the wind died down to a mere gale, Steve apparently couldn't stand it any longer. With fellow Modeleer Jim Whitlatch "needling" the Rossi .60 engine and assisting with the launch, Steve started his runs. And what a run it was! On a really small pond with very little room to turn after going through the 1/16 mile trap, he set the new world's mark! The big hydro ran as if it were on rails — no cavitating, no bouncing, no nonsense — just up and back through Wes Hunt's electronic light beam traps

so that there was no question of the timing being inaccurate. Wes, by the way, is a professional timer who uses the same equipment to time drag races for the full size hydros. The Los Angeles boat modelers who had watched Steve make his test runs knew the Sidewinder could "move," but even they were surprised when they found out he had raised the E-2 record from 36 to 49 MPH — a 33 $\frac{1}{3}$ % increase!

The Sidewinder used a completely stock Rossi 60 R/C engine with Fox heavy duty glo-plug. Fuel was a mix-





ture of KB 1000 and speed fuel. Radio equipment consisted of an F&M superhet with Bonner servos. The propeller was an original, designed and built by Steve. It is our feeling that by the time of the Delano West Coast Record Trials, Steve and his Sidewinder will be topping the 50 MPH mark.

Other records set at the two day San Diego affair included a Class B-1 mark of 18.5 MPH for the 1/16 mile and 15.0 MPH for the ¼ mile oval, set by Steve Muck of the L.A. Modeleers. Steve's boat was a proto of a Shore Patrol Boat with a Veco ball-bearing .19 for power and an Orbit 3+1 proportional system in the radio compartment.

Carl Borchert of the San Diego Argonauts established a new record for Class J-3 Electric with a time of 6.41 MPH for the 1/16 mile. Pittman motors were used, and the all-up weight of the boat was 9 lb. 6 oz.

Bill Hutchinson of Los Angeles, who originated the popular Hornet hydro design, ran one of the prototypes to a new D-2 class hydro record of 28.04 MPH. A front shaft intake model Super Tigre .35 was used for power. In the radio compartment was an RCM Digitrio with Spar servos. More and more proportional systems are being used by Western boatmen, and they really give an added advantage. The question is now — when is some manufacturer going to provide a good two channel proportional system at a reasonable price, designed for the needs of the boating enthusiasts?

Carl Offerman of the Argonauts used a modified Hornet hydro kit and Super Tigre .15 to establish a new Class B-2 1/16 record of 32.63 MPH. Radio was a Min-X superhet with Bonner servos. Carl's fellow clubmen, Jim Henry and Bob Folley both ran over the existing record with their small machines but couldn't get that necessary two-way average. Bob turned 34.5 MPH one-way only to have his engine die on the turn. Those three really know how to make .15 and .19 powered hydros roostertail!

Jim Whitlatch who holds the present ¼ mile oval D-3 record at 19.7 MPH was out for the 1/16th record. His new Super Tigre .40 rear rotor really "turns on" — to the tune, in fact, of a new record of 28.3 MPH! Jim used an Orbit superregen four channel with Bonner and Annco servos. Fox fuel and Fox heavy duty glo-plug along with a very touch pressure fuel system.

And so, seven new world's records — all on the first day of the meet. Sunday's weather was more like the claims made for it by the local Chamber of Commerce. In the Gas Precision events, Bill Gaughman, Steve Muck, Carl Borchert, and Jim Gale took the first four positions. In Speed Obstacle, Jim Whitlatch, James Henry, Steve Muck, and Bill Barton were the top contenders.

Sunday also marked the various multiple boat racing events with Carl Borchert and James Henry topping the list in Class A for .00-.20 displacement. In Class B, for .21-.40, Jack Krohn, Doug Nystrom, Jim Gale, and Al Gomez captured the first four slots with less than a 300 point spread. In the larger Class C event for the big mills of .41 and over, the team entry of Bob Gregory and Col. Sorrell was first, followed in close order by James Henry, Ron Wilson, and Don Baker.

Multiple boat racing has been a standard contest event on the West Coast for several years, with rules being quite similar to those used by the full-size hydros, including points for heat winners and mixing up the contestants the second time around, etc. Hydros are run against SK's and cruisers. The hydros go faster down the chute but can't turn as fast as the more maneuverable SK's and cruisers, so the races are not only exciting, but also sometimes quite rough — all in all, the high point of the West Coast meets!

For Southern boatmen, a new R/C hydro club is "in the budding" in the Little Rock, Arkansas, area. At the present time, two hydros are running — one a beefed-up Dumas Unlimited model with a Fox .59 engine and four channel Orbit radio system, owned by Jeff Haley. The second is a 42" original with O.S. .60 and 10 channel Orbit, owned by Dr. J. R. Warden, a Little Rock physician.

Next in line for completion is a fiberglass Challenger II with O.S. .50 and RCM Digitrio proportional system, being assembled by Joe Phillips. Joe is a late starter with the group, but beginning with a boat and engine of proved performance gives him a good edge.

Another "B-2" is an original design by Jerry Oberste — a design that he is keeping completely under wraps, but which is rumored to be powered by an Oliver Major.

Last, but by no means the least, are two more originals being built by Haley and Jim Yates as a competition team with RCM Digitrios being used in the radio room. Although they won't divulge any specifications, they have dropped the threat that if they don't knock over the existing record, they're certainly going to polish its heels! In fact, Haley adds — "we may not knock over anything but stumps and trees, but you'll have to admit that a little inflated ego has taken Cassius Clay a long way!"

According to our Arkansas correspondent, the Dumas Unlimited and one of the newly designed hydros were placed on display at the Annual Boat Show, held at the Little Rock, Arkansas, Barton Coliseum during the weekend of February 10-14 — attracting so much

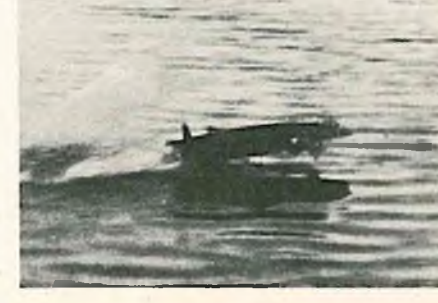

# 2ND ANNUAL R/C SCALE MEET

SPONSORED BY

MOVIELAND OF THE AIR MUSEUM • SOUTHERN CALIFORNIA COUNCIL OF R/C CLUBS  
RADIO CONTROL MODELER MAGAZINE

## JUNE 4TH AND 5TH

### *The Largest R/C Scale and Goodyear Meet in the World!*

FOR ENTRY BLANK AND DETAILS, WRITE:

**DICK TICHENOR, 137 Guinida Lane, Apt. #2, Anaheim, California**

interest on the part of the spectators that the model boatmen were almost asked to leave by the full-scale exhibitors!

A final word from the South is that the Arkansas boatmen are looking for a supply of cast Vitallium props, and they would certainly like to hear from anyone that can help them out. Contact Jeff Haley, Route #1, Box 43, Mabelvale, Arkansas.

Frank Delman, 200 Atlantic Avenue, Lynbrook, L. I., N. Y., announced the following schedule for IMPBA sanctioned meets to be held by the Nassau Model Power Boat Society for 1966. Site for each event is Whitney Pond, Manhasset, Long Island, New York, located at Northern Blvd., and Community Drive.

- May 14 - Gas
- May 28 - Gas
- May 30 - Gas - Family Picnic
- June 11 - Gas
- June 25 - Electric

- July 2 - Gas
- July 4 - Gas - Family Picnic
- July 23 - Electric
- August 6 - Gas
- August 20 - Electric
- September 3 - Gas
- September 5 - Gas - Family Picnic
- September 24 - Electric
- October 1 - Gas
- October 15 - Gas
- October 29 - Gas - Last Official Meet of season

Trophies will be awarded for first, second and third places in Gas, Electric and Gas and Electric combined events. All modelers are welcome and invited.

On the European scene, the fastest boat is a Rossi .60 powered "Pirana," owned by Kurt Matschulat. This is 28" length, 10" beam design. Weight is 3 kg. The Rossi has been substantially modified for additional horsepower. According to Holger Schweizer, our correspondent in West Germany, the most suitable prop for the Rossi is the X45,

the more popular X50 being less suitable for the European designs. Flywheel weight is 9 ounces. The radio equipment used in the Pirana is a four channel superhet with a Bonner Duramite used on Rudder and an Annco on the throttle. Testor X99 mixed with Castrol R is used for fuel. The current European record around the Naviga triangle used on their record trials is 22 seconds, or a straightaway speed of 70 km/h.

The sequence of photos of the three foot hydro turning over was taken with an 8 mm movie camera. Most of the German boats use a muffler-insert from the Volkswagen in order to quiet down the big mills - price is only \$1.50 and is quiet effective. All of the boats in the photo are polyester fibre with a red base color and metallic blue cowls.

We are looking forward to a report on the European internats at Vienna, Austria in May.

Ron Buck's Rossi-powered White Heat 60 during a test run at Lombard, Illinois. Boat features a surface prop and proportional R/C for steering and throttle. Ron is testing a new hull, new proportional system, new props, and new fin placement. May-be a record in the making?



# R/C

PRODUCTS BY

## STERLING

**A visit with Ed Manulkin of Sterling Models, the latter a 19-year pioneer in the R/C industry, introduces this new monthly series of RCM interviews with R/C manufacturers across the country.**



I'VE had the question from model builders and bankers alike — "How did you ever get into the manufacturing of model kits?" . . . It wasn't easy, but it sure was interesting, exciting, exasperating, exhilarating — all wrapped into one!

It's hard to believe that Sterling is coming into its 19th year of existence this Fall of 1966, but it's a fact nevertheless. The start was innocent enough, when I wandered onto model airplane activity in one of the great Philadelphia Department Stores about 1930 or 1931. The miracle and thrill of flight that I saw captured me so completely, that in all these years it has never left me.

In those years, of course, the only power we had was rubber bands and we sure made the most of it. I'll never forget the thrill of my first 30-second flight to qualify me for a "grease monkey" pin, and then getting deeply immersed in competition flying thru the old Philadelphia Model Airplane Club that, at one time, held 90% of all National records. In those days, a 30-minute indoor flight was as mythical as the now broken 4-minute mile, and outdoor twin pushers (what are they?) were regularly seen at all the outdoor

contests. Many of the present-day greats in real aviation received their Baptism of Fire during those formative years.

I was privileged indeed to be a part of the introduction of gasoline powered model airplanes, since as you know, Maxwell Basset (known as the Father of Gas Model Aviation) came from my home town of Philadelphia; as did Bill Brown, the designer of the first successful gas engine for model planes.

Some claims to fame are: an outdoor endurance flight with a rubber powered twin pusher of approximately two hours and 15 minutes; a 21½ minute indoor flight back in 1936 which ended on top the Dirigible "Miss Los Angeles." Everyone agreed that it might have reached that mythical 30-minute mark at that time. And then came the transfer over to gas powered flying.

Competition was very strongly sponsored by the old International Gas Model Airplane Association, formed by Charles S. Grant, then perennial editor of Model Airplane News. After several years of competition, the Association was incorporated into the newly formed Academy of Model Aeronautics, of which my original membership number was 1046; which, as a matter of fact, is

still my industry leader number.

When I came out of the service in 1946, I was offered and accepted, the position of Salesman with one of the largest Hobby distributors in the country. Although I had attended Luscombe School of Aviation and had an excellent background for returning to full scale industry, I accepted the position, and within a few months, became Sales Manager of the firm. I remained in this position for a couple of years, and then was drawn irresistibly to the idea of manufacturing my own products instead of just selling someone else's.

The first step in that direction was the packaging of hardware, followed by the design and marketing of an engine test block. The items sold quite well indeed and I had my hands full in keeping the fledgling business going at home while doing my job as Sales Manager for the wholesale model distributor.

The entry into the manufacturing business, coupled with my natural love for scale models, led quite naturally to the introduction of our first scale model kit, our C1 Monocoupe which is still in our line and selling well indeed, thank you.

Although some of the early records are not available, we calculate (and it should be quite close) that we have sold upwards of 30,000 of this particular kit alone.

From there on, the expansion and growth of the Sterling Models evolved naturally and it wasn't long before I was forced to resign my position as Sales Manager and take up the manufacturing chores full time. Until, our activities were located in the basement of my home and a half-dozen garages in the immediate vicinity for warehouse space.

It didn't take long to outgrow the home space completely and we finally moved to our first building in the center of Philadelphia. We had just about 4,000 square feet of space divided on three floors and a basement. It also boasted a rope-operated, muscle-powered elevator. When we received a load of Balsa wood in those days, it was an all-day job storing it. Today, we are able to store in about 40 to 50 minutes, a load three times that size.

We continued along with our scale model control line "C" series until one day we discovered Boats. At that time, radio control was just making itself known. Boats became quite popular because most modelers preferred to get their experience on the water where they not only could get their model back, but also keep their equipment intact. It's hardly ever you sink a model boat, while on the other hand, it was a regularly accepted fact that from time to time you lost radio contact with your model, resulting in a crash with possible loss of equipment, not to mention the model.

Our first model airplane kit designed specifically for radio operation was our "FS" series (Flying Scale), kit FS1 Piper Tri-Pacer, which also is still actively in the line, and is in fact, one of our better selling kits in the radio control line. There have been better than 25,000 of these sold to date, and they are still captivating the hearts of modelers and audiences alike wherever they are flown.

And so we went, one kit leading into another; and one event precipitating and triggering new designs and new kits until now, at the present time, we have better than 100 kits of various types and sizes in our line.

Over the years, the models built from our kits have won many prizes, contests both National and International, and records. We don't keep any chart of these, so specifics are not available. As far as sales records — this one might interest you — the largest selling gas model kit ever produced is our kit S1 Ringmaster, a control line model, which is being built by the second generation of modelers. (It has been said that more beginners learned to fly control

line on Ringmasters than any kit in the world.) This kit has sold upwards of a half million units and is still our very best selling kit, followed closely by the Baby Ringmaster and Ringmaster Jr.

You might be interested in our experiences with Joe Martin's Denight Special. We read about this beautiful model and exciting sport of team racing in R/C Modeler. It aroused all of our old model builder's desires that we thought now lay a bit deadened under the practical realities of operating a business instead of a hobby. It was my pleasure shortly thereafter to address the Valley Forge Sig-Nal Seekers in Pennsylvania on our new Command Master Radio equipment. At that time, the club members wanted to know if I had seen the Denight Special and what I had thought about it, and team racing in general. I told them that their enthusiasm was certainly matched by my own and we would look into it at once. The next day I contacted



Sterling's present factory — 40,000 sq. feet erected by the "pioneers" in 1886. Walls are 20" thick.

your editor, Don Dewey, and six weeks later (we believe this is a record for manufacturing speed), we were shipping the new kits of the Denight Special to the hobby wholesalers all over the world.

Our present plant comprises 40,000 square feet, a separate office building at the rear of the plant, plus a 15,000 square foot parking lot. Our equipment is automatic and semi-automatic and incorporates many design innovations not to be found anywhere else. There are six units in our Die Cutting Department, which gives us a theoretical production rate of almost 80,000 die cut sheets per day (printed, too) although we have never had a chance to use the full facilities. Our Packing Department has two main packing tables, both eight feet wide. One is 60 feet long, the other 80 feet long. We have packed as many as six different kits simultaneously and if necessary, we could pack up to eight if this production is ever warranted.

All parts are closely observed and inspected thru every stage of manufacture. They move from the Wood Shop, to the Die Cutting and/or Packing De-

partment and from the Die Cutting Department also to the Packing Department. As the run is being processed, the parts are assembled on the packing table. When all parts are assembled, the Forelady of the Packing Department inspects to see that all components are on the table and also in their proper sequence.

We pack in groups from two to six kits at a time, depending on the size of the kit. Our experienced packers (average time employed, 8 years) examine every piece that goes in the box as they pack and there is a formal inspection at a half-way point and then a second and complete inspection at the end of the packing line. One kit out of every group, whether it be two or six, is completely taken apart and inspected piece-by-piece, while on the line. Despite this strict attention, however, from time to time kits do get out with parts that should never have been packed, or parts missed entirely. We have resigned ourselves that this will be with us constantly, no matter what we do, since after all our inspectresses are human and do err occasionally. It is for this reason that we include our Unconditional Guarantee in every kit so that the consumer can write directly to us, telling us of any faults which are swiftly rectified by prompt part replacement shipments. We are the only manufacturer in the industry (as far as we know) that has a written, Unconditional Guarantee in every kit.

Although we have our little private crystal ball, it's not nearly as clear as we would like it to be. We believe that model flying will continue to increase as it has done the last eight or ten years. We believe that all phases, especially radio control, will continue to grow in volume as the equipment is simplified and easier for beginners and sport flyers to operate and kits are more easily assembled. Scale models will continue to gain in popularity, however, we believe this will be limited to those modelers that have sufficient skill to build them. The current sampling of foam wings, fiberglass fuselages, etc. will continue to expand as new materials become available. We don't believe that the present foam wing is the answer, since it does have many drawbacks that its proponents will not readily admit to. We believe, however, it is a step in the right direction for those modelers who prefer to fly instead of build. This trend will probably continue until ready-to-fly, or nearly-ready-to-fly models are available for them.

Sterling will continue to pay close attention to the modelers needs and produce the type of kits most requested. We always welcome comments from the modeler, since we like to share our deep-rooted love for this sport with anyone who cares to share it.

## BUILDING THE DIGITRIO

(Continued from Page 40)



A completed Digitrio system mounted on Fly-Tronics Circuit-Master.

cially after you have filed the bottom of a PC board down, is to use a large magnifying glass, such as used by stamp collectors, under very bright light. In many cases you can see threads of solder connecting lands or component leads which are loose in their solder mounds. I have also noticed that the receiver output is somewhat unstable when not under the load imposed by the decoder. There is a mistake in the overlay on page 21 in that the overlay shows the + side of C16 to the collector of Q-6, but the schematic shows the - side. I connected C16 as shown in the schematic. This error has not been given in the errata in RCM.

The decoder proved to be the simplest section to build. The PC board was made via the paint brush and dope route and was very easy. The use of the 2N3640 transistors makes for a relatively (to the receiver) roomy layout and no construction problems occurred. A serious parts problem occurred here in that the physical sizes of the tantalum capacitors were quite small and I could not find them surplus or in usual sources. I ordered most of them from World Engines and the .22 was so slow in delivery that I finally got it through Allied Radio at **twice** the World Engines price!

By the time the servo article was published, it was abundantly clear that a scratch builder was never going to duplicate the servo, hence I broke down and ordered four complete servo kits. Again I found some minor changes in construction necessary. Mount R10, the feedback element, as the **last** thing you

do!! If you follow the magazine procedures, you will ruin it when you file the bottom of the PC board to the required  $\frac{1}{32}$ ". Believe me I know! I installed the brass .006 wiper plate first as it requires some filing to remove burr edges. Also, I found that the PC boards as they come will not fit in the C frame, hence file the board to fit before you install any components. The hole for the R10 is also too small. By now I routinely install all components working from the left to the right and find things fit better. In the servo, pay particular attention as to how the transistor leads are bent. I found that pre-bending them in the proper direction before insertion and then being quite forceful when pushing in the transistors worked best. This is especially true of Q3-4 and if done properly they will not require any filings of the C frame. One problem with the servo was encountered during checkout, which was not apparent during construction. The knob on the output arm will not clear C8 the .001 capacitor. **DO NOT** remove all of this



Left to right: Ron Stoll, Butch Stoll, John Day. John Totton in background.

knob. Remove just enough of the inside edge to clear C8. One must install C8 as far toward the 10K resistor as possible. If not, as the output arm moves left, the brass fingers will hit C8 and lift. The only way to restart the servo is to remove the case and reposition the output arm. I had to remove C8 from all my servos and rebend the leads. If C8 will still not clear, I suggest getting the 3/16th square flat .001's from Lafayette Radio. The fingers on the output arm will require some lateral adjustment before they ride on the wiper plate and R10 properly. I found that a strip of nylon hinge material is an excellent "shoe horn" for these wipers.

With the servos completed, there was only one way to find out if they worked and that was to plug up the whole system and turn on the switches. With a flick of the switch, there was a great nothing. My first thought was, "Damn, another white elephant" (of which I have had many). No amount of knob twisting could bring any life. My scope showed wave forms at all decoder out-

puts, but they were all non-responsive to stick movement. Back to the beginning. My wave forms looked correct, but suspicious, especially the hiding pulse mentioned earlier. I suspected timing problems. I called up my best source of hypotheses, Dr. A. K. Scidmore, Ph.D. in E.E. and asked how to measure milliseconds. His solution was brilliant and simple. It is well known among computer engineers that ordinary 60 cycle AC has a period of 16.45 milliseconds, hence set up your scope to one cycle, lay a piece of masking tape along the base line and keep dividing by two until you have 16 divisions. Then put the transmitter wave forms up without changing any scope settings. Using this procedure, I found the period of my transmitter was less than 1 ms. not 6.5. After some milling around, I found that the timing capacitor C14 was a .002, not a 1.0. I had bought it surplus and it came in a package labeled 1.0, but eventually found that it was marked "203M," whatever that means. With the proper C14, the system was fired again and now all servos drove to their extremes with a great grinding of gears. A few twists of the trim and control pots soon brought the rudder and elevator servos under control. What a beautiful sight!! I soon discovered that buzzing in the servo can be caused by too light tension on the wiper fingers, so check this before changing any resistors as suggested in the article. The motor control servo could not be brought into action under any circumstances, so back to Dr. Scidmore. We spent about 3 hours playing with C9 in the decoder as it was obvious C and C were not timing properly. Finally Dr. Scidmore discovered that the problem was that the trailing edge of the pulse at C had too much slope and its mid-point was about 3.5 ms. from the leading edge of the next pulse. Changing R14 to 680 ohms cured this problem. Now the motor control worked.

In fooling around with my set, I find that it behaves differently in and out of the airplane, and with the transmitter cover removed. Once I get the airplane configuration stable, I plan to remove about 3 inches from all cables. The receiver system is quite sensitive to battery voltages and as Thompson points out, the motor control is the first to go. If the motor control servo does not respond perfectly, STOP, your batteries are already too low. I installed 7 medium cells for a power supply in the transmitter, but the new batteries read 12.5 volts so I cut back to 6 for a while at 105 volts.

The system in operation is a joy to behold and I currently have it in my Class II Orion. The possibilities for

(Continued on Page 54)

✓ TESTED, APPROVED, AND RECOMMENDED  
BY R/C MODELER MAGAZINE

# PIPER COMANCHE

An Acrobatic Scale Model for Multi RC



2" Scale - 72" Span  
.49 - .65 Engines  
Fully Cowl'd

"Midget Mustang pylon racer coming soon."

California Residents add 4%.  
Dealer Inquiries Invited.  
Send stamp for free literature.

Custom Crafted Kit 36.95  
Plans & Templates -- 5.00  
Fiber Glass Cowl --- 6.00

**JACK STAFFORD MODELS**  
12111 BEATRICE ST.  
CULVER CITY, CALIF.

- Fiber glass cowl
- Complete landing gear
- Jig built sheet fuselage
- Key constructed wing
  - 33 sq. ft. drawings
  - 100 custom finished sig balsa & ply parts
- No carving or planking

## QUALITY R/C ACCESSORIES by DU-BRO

### Du-Bro LINKAGE ARM

(FOR BONNER SERVOS)  
Ideal set-up for nose wheel and rudder or engine control where less throw is needed. .050 steel.

only 49¢  
Stock No. LA-3

### Du-Bro DUAL TAKE-OFF

FOR BONNER SERVOS

only 49¢

With a Du-Bro DURA-V-LINK it makes an ideal hook-up for dual or single take-offs. take-off from either end of servo. Brass.

Stock No. DT-4

### Du-Bro DURA-CONNECTOR & V-LINK

For proportional sets using disc servos.  
Stock No. DCL-2

only 98¢

### Du-Bro DURA-V-LINK

CLOSE UP OF CLEVIS

only 49¢

For use with Du-Bro DURA-CONNECTORS and Du-Bro DUAL TAKE-OFFS. Also ideal for other servos with eyelet style take-offs. Spring steel. Stock No. DVL-1

### Du-Bro DURA-COLLARS

Best collars available. Pugged cadmium plated brass. Threads will not strip. Complete with set screws and Allen wrench. Stronger than aluminum type.

4 FOR 59¢

1/16" DC116    3/32" DC332    1/8" DC180    5/32" DC532    3/16" DC316

### Du-Bro DURA-LINK GUARDS

For those who feel the necessity... a removable safety guard to "positive lock" all links.

4 FOR 10¢    Stock No. LG-10

### Du-Bro TB-2-TRIM BAR

FOR BONNER SERVOS

Can be modified to Ancco servos. Designed for inline or side by side hook-up. Lightweight.

\$1.95

### The ORIGINAL Du-Bro KWIK-LINK

CONTROL YOKE ASSEMBLY  
... for any control linkage!  
THE TOP QUALITY LINK

Split Coupling Sleeve    T.M. Reg.

3/4" thread on 4" rod  
Stock No. KL-49  
MADE IN THE U.S.A.    49¢

### Du-Bro 6 SPOKE DURA-HUB WHEELS

Permanently pneumatic stronger unbreakable

2 1/4" (1 3/4 oz.) - \$2.59  
2 1/2" (2 oz.) - 2.79  
2 3/4" (2 1/2 oz.) - 2.99  
3" (3 oz.) - 3.19  
3 1/4" (3 1/2 oz.) - 3.39  
3 1/2" (4 oz.) - 3.59

### Du-Bro POSITIVE ACTION WHEEL BRAKES

1/2 oz. each. Steel brake drum eliminates scoring. Spring steel control arm.

only \$7.95 pair  
WHEELS NOT INCLUDED

### SERVO MOUNTING HARDWARE PACK

BOLT (3 48)  
WASHER  
SPACER  
BLIND MOUNTING NUT

SINGLE PACK 55¢  
Hardware for one servo  
Stock No. SM 55  
Packaged 12 to card.

FIVE PACK \$2.39  
Hardware for five servos.  
Stock No. SM 239  
Packaged 3 to a card.

### Du-Bro BLIND MOUNTING NUTS

Can be used on 1/8" plywood (without sticking thru) and thicker. 4 per pkg. 3 thread sizes:

2-56 Stock No. BN256  
3-48 Stock No. BN348  
4-40 Stock No. BN440

EACH 20¢    Stock No. KL-12    49¢

**DU-BRO PRODUCTS • 7667 Milwaukee Avenue • Niles, Illinois 60648**

## BUILDING THE DIGITRIO

(Continued from Page 53)

medium size scale ships is unlimited.

In that I only built the servos from kits, the economics of the situation should be mentioned. If you order all the kits, the system, with four servos, will cost \$238.60. My system cost me \$170.79, plus about two dollars in postage, or a saving of \$65.81. The savings were accomplished in the following ways. The 2N3638 and 2N3640 were part of a larger order through "friends" and reduced the price of these transistors to about 40 cents. Most capacitors, both disc and tantalytic, were ordered through Electronics Control Design at 5 cents and 25 cents respectively. The transmitter trim pots (but not the control pots) were 3 for \$1.35 from Electronics Components. All diodes were from "Sam's War Surplus" in a package of 100 for \$1.50. All resistors were from Allied Radio in large lots at 6 cents or 9 cents each. All non-tantalytic electrolytic capacitors were from Allied Radio, sale packages of 10 for 59 cents and out of two packages I found all I needed. After all the penny pinching, there are only two places you can really "beat" the World Engines kits. One is the transmitter. I was able to shave about \$38.00 off the transmitter including a Bonner control stick for each. Second is the decoder. Here transistor prices make the difference. The receiver price was within a few dollars of the kit and I would highly recommend the kit. With my "vast" experience, I would recommend that the scratch builder attempt only the transmitter and decoder, buy the rest in kit form from World Engines.

The check-out procedures in RCM were predicated on the assumption that the system would work; mine did not. However, the oscilloscope timing trick is all one really needs to supplement the published accounts, as the wave forms are what count in check-out. FORTUNATELY, there is very little to twist, pull or push, which brings up lesson 3. When things don't work, STOP, THINK, and above all, never remove components. Start from the batteries and trace the voltages and wave forms through. Using this procedure, you can easily locate the broken wire, cold solder connections, or microscopic shorts that cause the trouble.

In the past I have built a number of systems which worked up to 95% of specifications, but were never flown because that last 5% was not attained. The Digitrio seems to have that last 5% engineered into it and as soon as the weather warms to above 50 degrees, I'm looking forward to a full season of true proportional flying.

# The Roostertail



The Official Publication of the  
International Model Power Boat  
Association

General Office:

2405 19th Avenue Broadview, Ill.

**A**T a series of meetings, attended by representatives of the various interested clubs in the Chicago area, the following racing rules are proposed.

That the suggested Multi rules printed in the February, March and April 1965 Roostertail (Radio Control Modeler) be adapted in full with the following modifications and additions.

1. That the number of entries per heat be limited to 6 (six).
2. That a heat shall consist of 8 (eight) laps of the standard 'A' course or a total distance of 1 (one) mile.
3. That two heats shall constitute a race and the winner shall be determined by the total number of points earned in accordance with the following schedule; 1st place = 400 points, 2nd place = 300 points, 3rd place = 225 points, 4th place = 170 points, 5th place = 130 points, 6th place = 100 points, Did not finish = 75 points, Did not start = 0 (zero) points.
4. That the first place boat in each heat is timed, and in case of a tie in the number of points the boat with the fastest heat shall be declared the winner. If a point tie should exist for any other position a runoff heat may be used.
5. That if sufficient boats are not available in a class, that class may be handicapped and run with another class. The handicap is to be determined by using the ¼ mile oval records for the classes involved. The handicap system appeared in this column last month. (This record is the annual published list from the Roostertail.)
6. That the Port Time be limited to 3 (three) minutes after which a

(Continued on Page 56)

**GANNET ENGINES** AMERICA'S FINEST R/C KITS **GANNET ENGINES**  
AND ACCESSORIES **NORCO CATALINA 36" L. O. A. 11" beam** AND ACCESSORIES



15cc OHV  
WITH MAG  
Tested, Approved and  
Recommended by RCM



Kit parts are individually cut and numbered for easy construction. Full size plans — P.P. \$24.50

NORCO NEWPORT 46½" L.O.A.; BEAM 13½"



Kit parts are individually cut and numbered for easy construction. Full size plans — P.P. \$39.50



15cc OHV  
STANDARD  
Tested, Approved and  
Recommended by RCM

COMPLETE ARRAY OF QUALITY FITTINGS

Send 10c in coin for free literature **Norco Marinecraft, Box 2192, Van Nuys, Calif.**  
COMING SOON: NORCO 'AVALON'

# R/C

## LOGICTROL II

FULL-HOUSE PROPORTIONAL

AMERICA'S ONLY EXPANDABLE SYSTEM 5 OR 7 CONTROLS

PROVEN RELIABILITY... NOT ASSUMED!

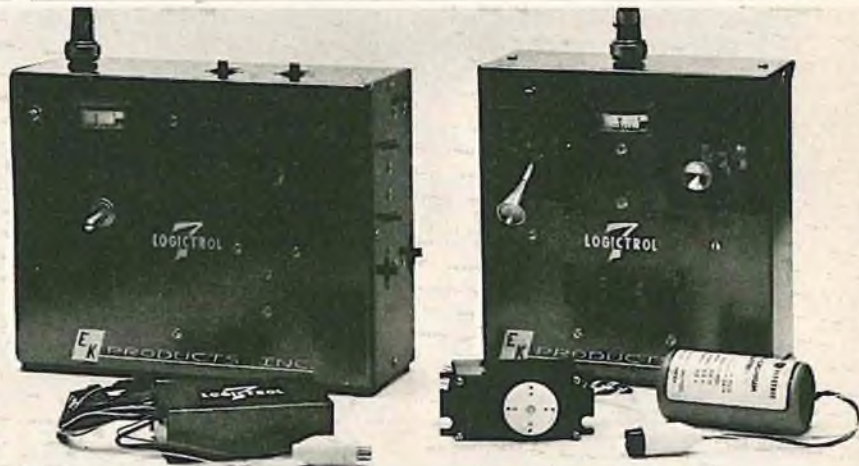

### 1966 CONTEST WINS WITH LOGICTROL

1st in Scale — Southwestern Championship, Phoenix, Arizona  
1st in Class III N — Southwestern Championship, Phoenix, Arizona  
1st in Class II — Southwestern Championship, Phoenix, Arizona  
2nd in Class III N — Southwestern Championship, Phoenix, Arizona  
1st in Class III N — B.I.R.D.S. Contest, Long Beach, California  
3rd in Scale — B.I.R.D.S. Contest, Long Beach, California  
3rd in Class III N — B.I.R.D.S. Contest, Long Beach, California

- Convenient Transmitter Size — 6" x 6½" x 2¼" (Dual-Stick Version)
- Small Receiver, Single Deck — 2" x 3" x 1"
- Low Flying Weight — only 23 oz.!
- Low, low parts count in Transmitter and Receiver
- High Transmitter Output — .75 watts
- Available on the 5 CB freqs., 6 meters and 72-76 mc (when FCC approved)
- New Powerful Servo with Dual Output — Push Pull or Rotary
- Small Servo Size — 1½" x 2½" x 1¾"
- Unsurpassed Servo Resolution
- Tested One Full Year
- Single or Dual-Stick Transmitters
- Fast Factory Service
- Polyurethane Coated for Vibration Protection

AND LOOK AT THE LOW PRICES ON LOGICTROL II

5 Dual Stick \$425 • 7 Dual Stick \$495 • 5 Single Stick \$450  
7 Single Stick \$520 • Extra Servo \$40 • Pro Brake Circuit \$10.95  
Special Flap Servo \$45

SEE YOUR DEALER OR ORDER DIRECT



**E.K. PRODUCTS INC.**

Distributor Inquiries Invited (714) 531-4960

14875 DILLOW STREET  
WESTMINSTER, CALIF. 92683

# 3 OF A KIND!

6 CHANNEL TO  
PROPORTIONAL RADIOS

T.W. Span: 37"  
W. Area: 1050 Sq. in.  
Wght: 5½ to 6½ lbs.

FULLY  
ACROBATICI



.29 to .60 ENGINES

dmeco's NEW LIVE WIRE

## "Acrobat"

FOR REALISTIC R/C ACROBATICS!

Mr. Average Flyer . . .

When you are looking for realistic acrobatics a Bipe is top! And when you want ease of flight and stability PLUS acrobatics choose a Live Wire design!

The Acrobat is a rare combination of simplicity and performance. 2 years of painstaking development have brought out the ultimate, an acrobatic model which will suit the most discriminating average flyer! Take a look at the "Acrobat" yourself!

30 Hour assembly . . .

Take a look at the most complete kit ever offered to you!

You don't build it, you ASSEMBLE IT like the plastic! All parts are precision machined to finished tolerances including the plywood fuselage with its integral struts. Nothing left to do but enjoy yourself!

It is a most complete kit including Canonic Fasteners, universal engine and shock mount, steerable trike gear, formed windshield and plastic Strip Hinges.

A COMPLETE DELUXE KIT, ONLY \$29.95

deBOLT MODEL ENGINEERING COMPANY

3833 HARLEM ROAD  
BUFFALO, N. Y. 14215 U.S.A.

## ROOSTERTAIL

(Continued from Page 55)

- 30 (thirty) second clock shall indicate the start of the heat.
- That the start be optional with the driver, either flying or release; however if the driver prefers to release start it must be from a point 20 feet or more behind the starting line.
  - That there shall be no engine restrictions, except displacement.
  - If one-half or more of the boats entered in a heat die (stop) on the course before the heat begins, that heat will be restarted.
  - That all R/C equipment must be compatible with standard Citizen Band frequencies (super-hetrodyne).

The above rules can be used at sanctioned regattas until modified or approved at the annual meeting or by special referendum by the order of the IMPBA President.

For some time, there has been a need

for an event which will give both the old timer, and the boating novice an opportunity to compete in multi-boat racing on an even basis, with skill in driving and a little bit of luck being the two prime factors in the race. The following is the result of many hours of thought and consideration on this matter. After you have read it, take a minute to drop a post-card to the IMPBA General Office and give your opinion. If you like it, put down "yea," if you don't you write down "boo." Any comments you have, on any or all of the proposal, are invited.

Proposal to establish a **NEW** class of R/C Multi-boats, hereafter to be known as the **SPORTSMAN CLASS** which will be in **addition** to existing racing classes.

- This class is to be for multi-boat racing only.
- The engine size shall be limited to .47 cu. in. in Type 3, planing hulls (nonO-step). On hydroplane hulls the engine shall be limited to .36 cu. in.
- ALL engines must be **stock**, that is, all parts used as supplied by the engine manufacturer — with no modifications—filing, polishing, etc. allowed. The only exceptions to the above are the glo-plug, screws, mounting bolt holes, water cooling jacket, flywheel, and coupling.
- The minimum boat length for a type 3 planing hull shall be 34" and for a hydroplane the minimum length shall be 29", overall.
- The minimum weight of either type of hull shall be 5 (five) pounds.
- All boats shall use a common fuel to be supplied by the regatta sponsor, and the brand name and type of fuel must be identified on the race announcement letter.
- NO** pressure fuel systems are to be allowed, and all fuel tanks must be of the translucent type (plastic bottle).
- No surfacing type propellers or

drive systems are allowed.

- Eight laps of the standard 'A' oval (one mile) shall constitute a heat, and two heats shall be a race. If more than two heats are necessary because of the number of entries, the boats in each heat must be rearranged into different groups.
- The boats shall turn right in the first heat (clockwise) and to the left in the second heat (counter-clockwise).
- The speed control used must be capable of slowing the boat to a speed where it may be safely caught, by hand.
- A radio frequency color flag must be used, on the boat, with a triangular shape of at least 1½" hoist by 2" long flying at least 4" from flag bottom to the deck.
- A \$5.00 engine/hull protest fee as covered in the rule book shall be used in this class.

Your comments are invited, so that we may present a proposal to the membership for vote, which reflects the feelings and ideas of all the active members.

**NEW! — NEW!**

Self Threading Aileron Horn



\$1.25 & 25c  
POSTAGE  
PER PAIR

No wheel collars needed. No gluing. 100% safe, cannot come off. Fully adjustable.

**AILERONEE**

T.M. PAT. PEND



SELF THREADING  
ELEVATOR AND  
RUDDER HORN  
FULLY ADJUSTABLE  
PRICE 80c PLUS  
20C POSTAGE PER PAIR

Order direct if no Dealer near you. Dealer inquiries invited.

**DARIN BROS.**

5221 ALLEN ROAD  
ALLEN PARK, MICHIGAN 48101

## The Only 78" GREAT LAKES

- "Modified" . . . in easiest R/C Kit ever . . . 12-Hour assembly
- All Hand Cut (Not Die Crushed) Carefully Fitted Parts
- Pre-formed Landing Gear and Cabane . . . Both Removable!
- All Aerobatics . . . Flies Scale . . . Completely Realistic \$56.25—Send Check or M.O.

**VIC'S CUSTOM MODELS**

618 Cowpath Rd.,  
Lansdale MR 1, Pa. 19446

Also—New from Vic's Custom Models 67" RC

**CONVERTIBLE TRAINER**

• 6 Hour Assembly  
• Shoulder Wing • Pre-cut **\$19.95**



along the power cord to prevent shorting when the battery is carried in the tool box. The charger is a burn-out proof unit featuring transformer isolation to prevent shock hazards. A charging indicator light glows softly for proper charging but glares brightly if the output is accidentally shorted or hooked up backwards to the starting battery. Price of the starting battery is \$14.95. Battery charger is an additional \$14.95. Circle #7 on the Reader Service Card.

Johannes Graupner, 7312 Kirchheim/Teck, Postfach 48, Germany, has announced a 14 channel digital proportional system to be available shortly. Although no details are available at present, you may be quite interested in the complete line of Graupner kits and radio systems. For further information on this line, Circle #8 on the Reader Service Card.



North El Monte Hobby, 4720-22 Peck Road, El Monte, California 91732, has a complete stock of the new Titebond aliphatic resin glue by Franklin Glue Company. This is an aliphatic resin glue of outstanding strength that combines the best features of white glues and epoxies while eliminating the disadvantages of both. This is not a catalyst type glue and it is ready to use as it comes out of the dispenser. Setting time is slightly faster than white glue. In addition, it is not water soluble and is quite easily sanded. It is unaffected by lacquer and varnish solvents and is fuel proof. The strength of the glue equals or exceeds any epoxy glue we have tested. On all test panels we ran, including balsa end joints, lap joints, laminations, balsa to ply joints, etc., the wood broke in every case leaving the joint intact. This glue has been thoroughly tested by RCM and is being used exclusively on all of our construction projects. We feel it is unexcelled and unequalled, and is recommended for all general aircraft construction applications. Circle #9 on the Reader Service Card.



## PROPORTIONAL HEADQUARTERS

(Export Wholesale Only)

Bonner Digimite (4 & 8)

C&S Digicon II. (3, 4 & 6)

Citizen-Ship AP (2+1)

Controlaire (5)

Deans Proportional (4 & 8)

D.B. Quadrplex CL-5 (4+1)

D.B. Quadrplex 21 (3+1)

E.K. Logitrol (3, 4 & 7)

F&M Digital (3+1 & 5)

Kraft Custom KP-6

Micro-Avionics (5)

Orbit 7-14 Digital (7)

Orbit Quad Analog (4)

Orbit 3+1

P.C.S.-5

R/C Modeler Digitrio

(3, 3+1 & 4)

And more coming soon!

Now exclusive export distributor for Pettit

"Hobbypoxy."

Trade only . . . Send for new Nov. 1965 Bulletin listing and evaluating the finest in R/C equipment, kits, accessories, foam & fiberglass and products for the fabulous Goodyear event. A special listing of parts and components is also available for Original Equipment Manufacturers abroad.

## EXPORTATIONS

2137 N. Marianna Ave., Los Angeles, Calif. 90032  
Tel. (213) 221-6968, Cable: Extronic

## JENSEN

## NEMO HOBBY DISTRIBUTORS

4720-22 Peck Rd. • El Monte, Calif. 91732 • (213) GI-8-8913

ENTERPRISES

EXCLUSIVE DISTRIBUTORS FOR THE NEW KWIK-FLI II. BY JENSEN ENTERPRISES. SEE YOUR DEALER OR ORDER DIRECT. DEALER INQUIRES INVITED.

### The Kwik-Fli, a consistent choice of champions!



**PHIL KRAFT**  
1ST SOUTHWESTERN  
REGIONALS FLYOFF  
2ND BIRDS ANNUAL



**CLIFF WEIRICK**  
1ST SOUTHWESTERN REGIONALS  
1ST BIRDS ANNUAL

NOT SHOWN: JERRY PULLEN, 3RD BIRDS ANNUAL

Span 60"  
Area 620"

Designed By PHIL KRAFT

Engine .45 to .60  
Flying Weight 6 lbs.  
Class III

\$35.00

At Your  
Dealers Now!

The Fabulous . . .

**KWIK-FLI MK2 KIT**

by **JENSEN** ENTERPRISES

No Die Cutting • All Parts Machine Cut or Sanded to Exact Size with all Bevels and Angles Cut  
Takes the Work out of Building — Leaves only the Pleasure  
**TESTED, APPROVED, AND RECOMMENDED BY RCM**

**NEW!**

**JENSEN**

Accessories  
Available Separately

Steering Arm	-----95c	Main Gear	-----90c
Kwik-Fli Canopy	-----		-----\$1.00
Aileron Horns	60c	Lo-Profile Nose Gear	70c
Kwik-Fli Wing Kit	-----		-----\$14.95



**C-6 - C-7 - C-18**  
Nylon Insert Lock Screws - A positive way to keep your engine and Servos locked in place. C-6 - 4/40 x 1", C-7 - 6/32 x 1 1/2, New C-18 - 4/40 x 1/2 for Servo Mounts. C-6 Pkg. - .45 C-7 Pkg. - .45 C-18 Pkg. - .35

# NEW

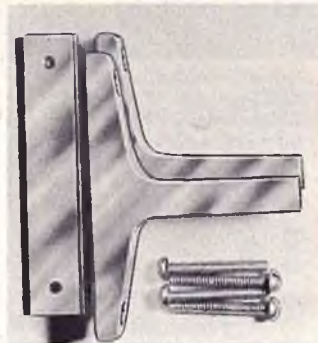

**C-12 - C-14**  
New R/C aluminum and magnesium radial beam mounts can be used with all R/C engines. Two sizes, C-12 small - \$1.80; C-14 large - \$1.95.

## FLASH

- Aristo-Cat wins 1st at Nationals, flown by Nick Neville. Kit now available. Price \$24.95.
- Idle-X places 1st at Nationals in Class 1 and Class 2.
- Bill Northrop, using Idle-X Fuel, sets new altitude record. Temperatures varied from 85° F. to 32° F. yet engine ran with consistent power throughout the whole flight.

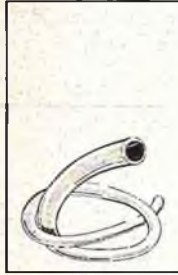

**C-1**  
No-Noise Nylon Cable Tubing - 18" long - Pkg. - .35

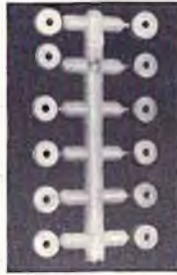

**C-2**  
No-Noise Nylon Retainers - for 1/16" wire - Pkg. - .45



**C-3**  
No-Noise Nylon Clevis - for high strength, smoother control, positive fastening action and vibration-proof. 2 pair - Pkg. - .50



**C-4**  
Fu-Seal - Fuel proof, adhesive back seal. Pkg. - .50



**C-5**  
No-Noise Nylon Builder Accessory Kit - all nylon parts. Pkg. - .60



**C-11**  
Spring Wire Nose Gear Pkg. - .75

If your dealer does not stock MIDWEST, write to factory for prompt delivery.

## MIDWEST PRODUCTS Co., Inc.

400 So. Indiana, Hobart, Ind.

### CUNNINGHAM ON R/C

(Continued from Page 10)



no engine overheating resulted. Idle was vastly improved and only one bad effect was noted. The latter concerns the fact that if you are flying in a group of non-muffled engines, you can't hear yours! This can be a little disconcerting, as it is surprising just how much we tend to fly by sound. The most interesting reaction is to make a long, low pass over the field and see your ship,

streaking along, with so little noise that you are amazed that it isn't really coming down for a landing!

#### Construction

The parts needed for the muffler can be purchased from the corner hardware store and the local hobby shop. The only item that gave us any trouble was the end plugs. These were finally made for the test mufflers by a friend that is a machinist. If you can't locate someone to make them for you, you can use wood plugs for a brief time. I used the latter on the muffler for the Merco and they held up long enough to tell me that I was on the right track. Of course, they smell something like a barbecue pit when the engine is burning and the exhaust is charring the wood.

Chart #1 gives the relative sizes of muffler cans to use for each size range of engine. This has been worked out based upon a factor of seven times the cubic displacement of the engine. The automotive book came up with a total factor of about thirty times the volume of one cylinder, so I tried a factor of seven. It seems to work quite satisfactorily. The tail pipe was reasonably short on the Merco, medium length on the Fox, and full length on the Veco and Ueda's. Try a full-length piece of tube first and cut it back if need be. Slightly flatten the end of the exhaust pipe as this helps to smooth out the sound wave.

One of the main things to remember is that you want to silence the engine, yet get the spent gas out of the exhaust and away from the engine. The muffler can should be of a material that transmits heat rapidly and yet is light and won't corrode. Reynolds Do-It-Yourself aluminum tube is much too heavy. I found a shiny, extruded aluminum tube with a wall thickness of about 1/32" at the hardware store. This was intended for use as shower curtain rod and is perfect for our application. If you can find aluminum tube at the hobby shop big enough for the exhaust stack, use it. I could only locate brass tubing which was heavier but large enough in diameter. Use 3/8" tube for the Fox and other engines of this size. 5/16" was used on the Veco and Ueda's.

The charts and drawings should be enough in the way of construction information. Use a soft wire to attach the muffler to your engine, or if you want to be fancy, construct a strap and bolt arrangement. One of the mufflers was sealed shut with epoxy glue which promptly melted from the hot exhaust gases. Another was sealed with a product called Muffler Seal, and this worked very well. Save the rest of the tube to patch up the family bus.

A word of caution - **do not** use one of these mufflers on a brand new engine! This was tried, during bench break-in, and the result was an engine

# A Sweetheart of a Radio by PROPORTIONAL CONTROL SYSTEMS

The PCS 5 Channel Digital Radio Provides  
The Ultimate in

\* PERFORMANCE

\* RELIABILITY

\* ECONOMY



Developed and Manufactured by  
Cliff Weirick and Jerry Pullen

- Complete System Ready to Install Includes:
- Transmitter \* Receiver \* 4 Servos
  - Power Packs \* Wire Harness with Switch
  - \* Chargers and Cables

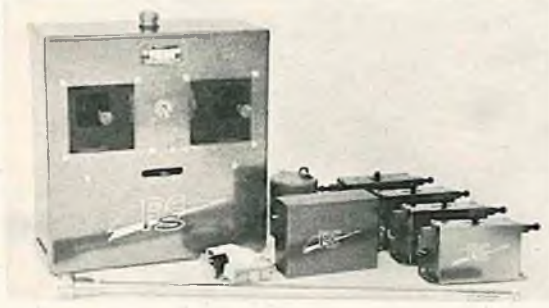

**FACTORY DIRECT ONLY**  
**\$ 299<sup>95</sup>**

Additional Servos \$32.95 each  
California Residents  
Add 4% Sales Tax

## PROPORTIONAL CONTROL SYSTEMS



4963 1/2 Valley Boulevard Los Angeles California 90032 Phone Area Code 213 225-0909

that peaked out at a sick idle! Be sure your engine has been broken in **without** the muffler before tying the can to its tail.

This is not the final answer to mufflers, but does give you a method of making a good silencer for your mill for about a buck. Remember, too, that when you test your muffler on the ground, it will sound a lot quieter than the unmuffled engine, but the real thrill will come when your ship is airborne.

Chart # 1

Engine Displacement	Length of Muffler Tube
.19	2"
.29	3"
.35	3 1/2"
.40	4"
.45	4 1/2"
.49	5"
.59	6"
.61	6 1/4"

Since this column began, I have received many interesting letters. These are sent along by the magazine, but due to their work load, it often takes two or three weeks to get to me. So, if you have any questions that I might try and answer, or pictures and sketches of what you are doing, drop me a line. The home pad is 5333 Wooten Drive, Fort Worth, Texas.

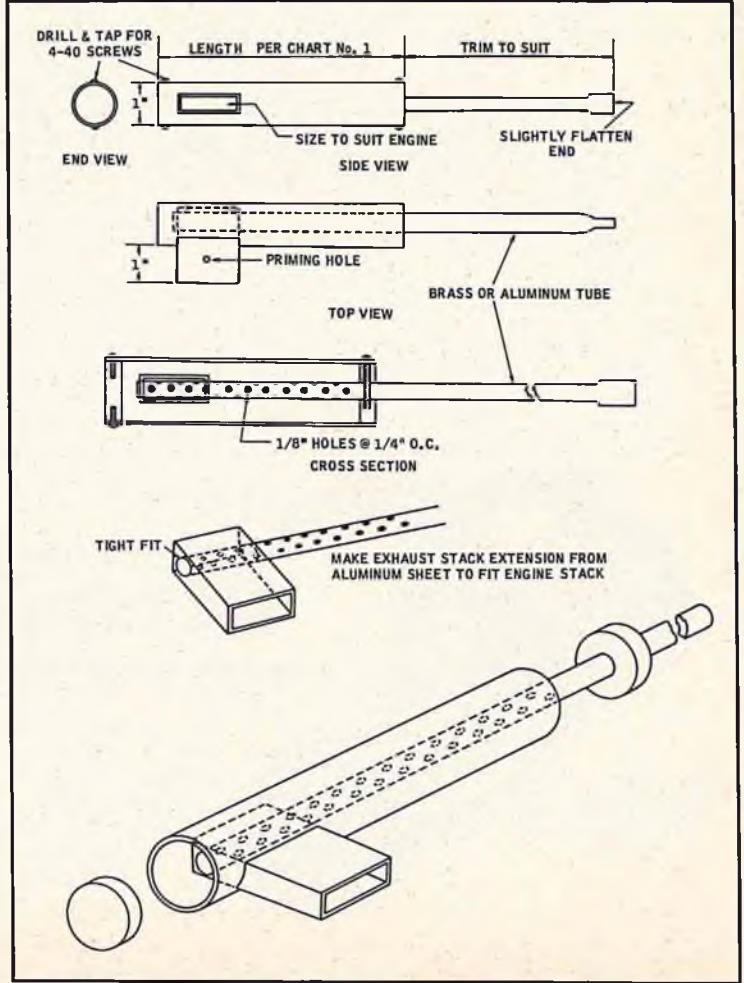

(Continued from Page 14)

# FIBRE-FOAM PRODUCTS

The ONLY Molded R C Wing Available in the World!

**MOLDING MEANS PERFECTION AND TRUENESS!** Wing panels removed from a female mold totally fabricated, glass fibre reinforced, totally covered in pure white and ready for finishing with ANY finish. No sanding or primer required. We formulate our own foam. This is not a gimmick — it is the biggest breakthrough since balsa!

**NOW AVAILABLE:** Candy, Sr. Falcon, Kwik-Fli II and other configurations. Send air mail stamp for detail sheet, prices, and FREE sample.

**FIBREFOAM PRODUCTS** 720 E. IMPERIAL  
EL SEGUNDO, CALIF. 90245

Another **aj** First!

N.M.P.R.A. APPROVED

THE  
**AEOLUS**

**GOOD YEAR**

**PYLON RACER**

**Fiberglass Fuse**

The AEOLUS, Designed by DICK RIGGS

Now — save half the time in building your own, beautiful fiberglass AEOLUS — a top Good Year performer. Complete with fiberglass fuse, high-impact plastic cheek cowls and wheel pants, full plans.

**\$28.50**

**NEW! FOR R.C. MODELERS!**

**SKY-riter**

**SMOKE CARTRIDGE**

Add realism to your flying with high density smoke. Non-toxic, non-explosive 6-inch cartridges.

**SKY-riter, each ---\$1.29**  
**Cartridge Holder ---\$1.95**

USE COUPON IN AD ON FACING PAGE.

**ACTION INDUSTRIES, INC.**  
4125 Reisterstown Rd.,  
Baltimore, Md.

Tilt! Right away I knew I had “over-explained” the model to Bud. It took some doing, but I finally convinced the agent, who had garbled Bud’s information, that my trip was personal, and so was the equipment. We hung up, bidding each other pleasant goodbyes after chuckling over the misunderstanding.

Next day. Another phone call.

“This is United, Mr. Willard. We certainly want to do all we can for you, but we just **can’t** let you take a package **nine feet** long into the passenger cabin!”

Whup! There we go again. Patiently, I explained it was **nine inches**, not nine feet, and the length was thirty-six inches. This time I was careful to use the same unit of measurement. I even made him write it down and read it back to me. Another chuckle, and pleasant goodbyes.

Shortly thereafter, the phone rang again. Yep, United. The girl was nice, but obviously worried.

“About this airplane, Mr. Willard. Our operations people are concerned about the weight. We musn’t overload our DC-8’s, you know.”

That threw me. By now, I guessed that Bud’s message to the reservation office must have been written in Sanskrit and translated into Esperanto before the English version hit San Francisco. Slowly, carefully, and with great deliberation, I replied.

“It weighs slightly less than two pounds, Miss. Now, if that’s too much for the DC-8, do you think I ought to try American’s 707?”

“Oh, no, sir! We can fly **anything** that American can. But we didn’t know airplanes could be so **light!** We’ll handle it fine!”

And you know what? They did. All the way. There’s nothing like competition to bring out the best in everything. Even airlines.

The first part of this column was written while en route to Toledo. This part is being written after I returned and had time to digest the things I saw, heard, and participated in during the Mid-Winter Conference.

Like I said — competition brings out the best in everything. Nowhere was this more evident than at Toledo — both in the models on display and the manufacturers’ items. You’ll see a lot of

(Continued on Page 72)

# HAPPY WING CORES

Serving the modeler —  
**DIRECT**

TYPES — Include Instructions, Precut Dihedral Angle,  
Servo and Dihedral Brace Cutouts

BEACHCOMBER	CANDY	ROBIN		VIPER
BOSCH TAPER	KWIK-FLI	TAURUS	\$11 <sup>95</sup>	\$13 <sup>95</sup>
SWEEP Taurus	KWIK-FLI II	CITRON		

L.G. Mounts Included with Above

FALCON SR.	JENNY	*ARISTO-CAT	INSTRUCTOR	\$9 <sup>95</sup>
*FALCON 56	STORMER	*No Servo Cutout Unless Requested		

**MATCHING STAB CORES (Except Robin & Viper)** \$3<sup>95</sup>

**IMPROVED "KWIK STICK" Foam-Balsa Contact Cement.** Pt. \$2.50

NOW AVAILABLE

**GREEN DOT FOAM** \$5<sup>95</sup> pr.  
Blocks 3" x 12" x 33½"

SEND CHECK OR MONEY ORDER  
(NO C.O.D.) — POSTAGE PREPAID  
Satisfaction Guaranteed

**CUSTOM PRODUCTS**

1205 green acres rd.  
ph. 504-888-0843



metairie, louisiana  
zip code 70003

## PHELPS PULSER

(Continued from Page 36)

The completed Phelps pulser modified for maximum flexibility for today's updated single channel pulse systems.

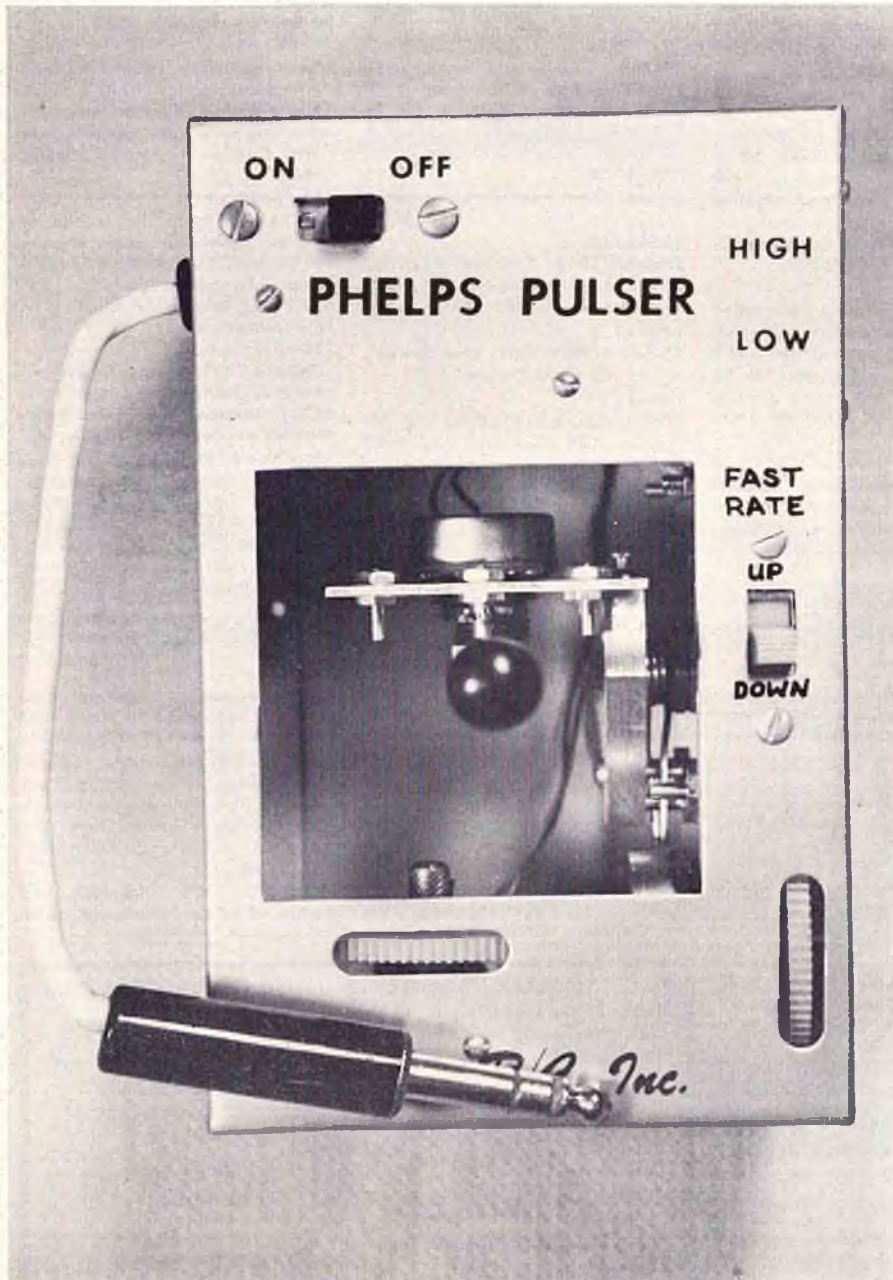

thought was to substitute a 90-degree, 15K pot, but I couldn't find such a pot listed in any catalog. Ace lists a 90-degree, 30K pot, but if we put a fixed resistor in parallel with it to get our 15K net resistance, the circuit not only becomes non-linear but the percent change to either side of neutral is significantly different. The only alternative was to make a 80-degree, 15K pot out of the 270-degree, 50K pot already in the pulser. This operation is not too difficult if you use the right materials. You have to paint over a total of 190 degrees of the carbon resistance element in the pot with a conductive paint.

It would be a good idea to locate the conductive paint before doing any disassembly of the pulser. I used Silver Print, a GC Electronics product. Silver Print is expensive and you need only a very small amount, so scout around for some ham operator, electronics experimenter or some repair shop that has some. If you can pay someone 50c or so to paint the film strip for you, you can save some money. If you want to use something besides Silver Print, first try it on something else and check on the conductivity. I tried Plastic Aluminum and some aluminum paint, both of which were pretty good insulators, and Walsco Television Tube Koat, which is conductive but doesn't adhere well to the carbon film in the pot. Another possibility is Walsco's Carbonex, made for repairing worn carbon film elements. However, only one of three dealers I tried had any Carbonex, and all 3 bottles he had were dried out. Also, there is GC's Copper Print, which is only slightly less expensive than Silver Print. If you can find an old pot you don't need, it would be well to practice and experiment with it before working on the pot in your pulser.

(Continued on Page 66)

# QUALITY CONTROL in RADIO CONTROL

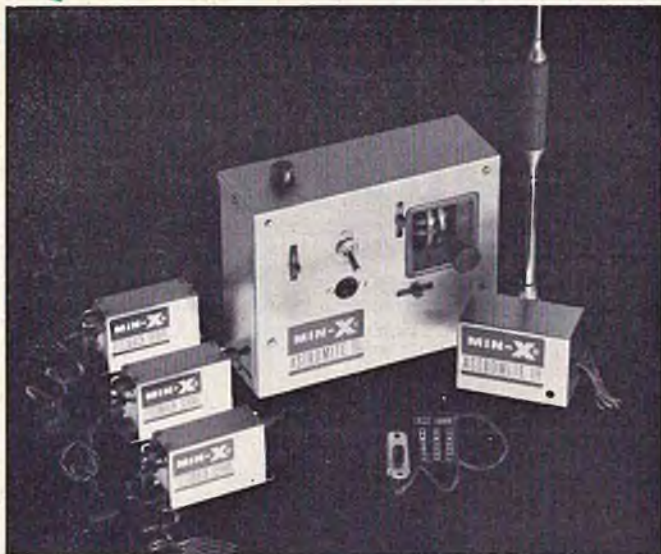

## ASTROMITE III

Single stick. Three fully proportional controls.

Two controls with trim.

**\$299.95**

System includes transmitter, superhet receiver, 3 servos, prewired junction board, transmitter power pac and airborne power pac. (Charger extra \$14.95.) (Astromite VI \$499.95)



## GG-1200

Two proportional controls with engine control from one actuator All simple push rod hookup. **\$119.95**

Includes transmitter and superhet receiver, actuator and prewired harness. Same system with "CAPRI" superregen receiver. GG-800. \*Less batteries. **\$99.95**

# MIN-X<sup>®</sup>

MIN-X RADIO, INC.  
8714 GRAND RIVER  
DEPARTMENT 15  
DETROIT, MICH. 48204

Send literature today. I enclose 25c for handling.

Name \_\_\_\_\_

Address \_\_\_\_\_

City \_\_\_\_\_ State \_\_\_\_\_

## PHELPS PULSER

(Continued from Page 64)

To make the changes, remove the elevator stick pot from the pulser and disassemble the pot by bending up the four tabs that hold it together. The center terminal rotates up and out. Figure 4 shows the disassembled pot. The resistance element is a very thin carbon film deposited on a horseshoe shaped phenolic board. Measure the resistance between the outer terminals: it should be between 45,000 and 55,000 ohms. Compute your desired final resistance (divide measured resistance by 270 and multiply the result by 80). Actually, your final resistance will probably be higher as the conductive paint may not be 100% effective in shorting out the painted area.

Lay out two lines, crossing at an 80-degree angle, on a piece of thin cardboard. Using the intersection of the lines as a center, draw a 1/16-inch diameter circle. Cut this circle out and lay it inside the resistance element, orienting the cardboard as shown in Figure 4. Very lightly scrape the carbon film with a sharp knife over the indicated area. The idea here is not to remove the film but just to roughen the surface some and remove any oil or grease deposits.

It wouldn't hurt to wash the film with carbon-tetrachloride, but don't use any solvent or chemical which might leave any kind of film over the carbon.

Next, paint over the scraped areas with the conductive paint. After the paint is dry, measure the resistance between ends of the film strip. If the resistance between outer terminals is more than about 5K higher than the calculated final resistance, the paint didn't bond well to the carbon film. My own pot came out at 20K, 5K above the calculated final resistance, and the results have been satisfactory. If at first you don't succeed, scrape off **carefully** and try, try again. You could paint one continuous 190-degree arc on the pot, but here a perfect bond is essential between the conductive paint and carbon film or else the pot resistance will not be balanced around neutral. After you are satisfied with the paint job mark the pot shaft and reassemble the pot with the shaft at the center position (wiper at center of exposed carbon film).

Mark the pulser case and make the required cutouts for the 4PDT switch. Rectangular holes for a slide switch can be made by drilling a series of small adjacent holes around inside the lines, cutting through the soft aluminum between holes with a knife and finishing out with a small flat file. Ignition point files work very nicely for this job. I

put my rate function switch directly to the right of the control stick as shown in Figure 5. This is a convenient spot in relation to the two rate pots. Now is the time to mark the case. Use the terms shown in Figure 5, or make up your own if you prefer. Electronics decals, dry-transfer decals, or hand lettering can be used, whichever is convenient.

Wire the rate function switch before installing it in the pulser case. Leave plenty of wire to go from the switch to each pot, and color code the wires if you feel you need it. Install the switch and wire it to the two pots as shown in Figure 3. I drilled a small hole through the pot carrier plate for the leads going to the trim pot. Find the center position of the rate trim pot and set it there. Connect the battery and turn on the pulser. Flip the rate function switch back and forth and listen to the relay, or reed relay. If everything is Okay, the pulse rate should not change in either switch position. Now try the trim and stick pot functions in both rate function switch positions; rotation in the same direction of either pot should change the rate the same way. If not one pot must be wired backwards.

When you are satisfied that everything is functioning correctly, complete the pulser assembly, button up the case, connect the pulser to your transmitter and you are ready to fly.

## DESIGNED FOR THE JOB . . .

### Spring-Centered Proportional Servo

#### IDEAL FOR USE IN ANY PULSE SYSTEM

- **FAST-ACTING, STRONG CENTERING**
- **FULL R.F. NOISE SUPPRESSION HAS BEEN ADDED TO THE 5-POLE, DOUBLE BRUSHED, HIGHEST QUALITY MOTOR**
- **LOW CURRENT DRAIN**
- **ALL WORKING PARTS VISIBLE TO MODELER**

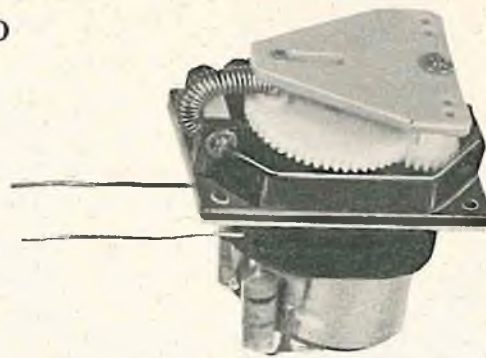

**HR1 \$15.95**  
See Your Dealer

#### OTHER ACTUATORS AVAILABLE

MODEL LR3.....\$19.95  
MODEL HR2.....\$18.95

Send 15¢ for LATEST CATALOG

Small size—1" x 1 5/8" x 1 1/2"  
Light weight—1 1/4 oz.  
High Output—22 oz.

Join AMA's Chartered Club Program

**TAKE OFF**  
PRODUCTS BY RAND MFG. CO.  
8909 HUBBELL  
DETROIT, MICHIGAN 48228



### TOP OUT

(Continued from Page 12)

*mending we turn Class I into something like flying a kite! I believe there is a way for the U. S. to send a Class I team to a future World Event to compete against other countries—and think equal support should be given all classes. . . .*

Jackie Gardner  
Jackson, Mississippi

In answer to a letter from Jackie Gardner dealing with Class I chances of realizing FAI competition status,

John Worth explained his view of the problem:

*"Should FAI ever put Class I into the world championship schedule, we would most certainly field a team, if at all possible. But the possibility of FAI doing that is almost non-existent. . . . We have only one vote. . . .*

*"Perhaps, Class I needs some fresh thinking to make it more distinctive from Class III—an event worthy of itself rather than by comparison to something else. Food for thought?"*

Sincerely,

John Worth  
Executive Director

Food for thought, it is, but based upon the almost unanimous opinion of those who fly Class I, not anywhere in the direction expressed by Mr. Worth! It's more than clear that Class I flyers want official efforts in connection with promotion of FAI activity to vigorously take on a pro Class I emphasis—as it should have been done before the CIAM action. General "fresh thinking" type admonitions at this point is like locking the barn after the nag has been filched! Class I flyers are aware that European mono-controlists have been shoved into the background by short-sighted status quo-ers but still believe an FAI event is possible along with a European resurgence of RO along the lines of our multi-rudder as a bonus to

well-conceived and executed American leadership.

It should be fully realized that in considering Class I for FAI we're really involved with the entire American FAI R/C program—not just the Class I segment. It's well known there's official dissatisfaction with the current selection process and that financial support is always a precarious matter. This adds up to the need for broad support from all RC'ers, not just the contest buffs in Class I, II, III—as well as others—who comprise about 10% of the organized membership. It, therefore, doesn't make sense to alienate any major segment whom will aid greatly in promoting FAI support among that other 90% who really may not care much otherwise, one way or another. . . .

Instead of diversionary suggestions and negative defeatist attitudes dished up so far, rudderites need imaginative and constructive effort from their national organization to help them build activity and widen activity generally, as well as FAI participation. If it's necessary to demonstrate Class I advances as they have developed under our rules and field experience, and thus encourage similar steps elsewhere—then, let's get on with it! As a starter, why not invite the next U. S. Class I champ as a

(Continued on Page 68)



# NEW—JUST OFF THE PRESS

Send for our new catalog listing the finest line of test equipment and supplies at reasonable prices. only 25c

**DEALERS:** Your inquiries are also invited. Write on your letterhead.



**C. H. C. HOBBY WORLD** P. O. BOX 208, COVINA, CALIF. ZIP 91722

NAME \_\_\_\_\_

ADDRESS \_\_\_\_\_

CITY \_\_\_\_\_ STATE \_\_\_\_\_ ZIP \_\_\_\_\_

**SEND FOR NEW CATALOG—** listing many new and different radio control, tools, and electronic items. You will be amazed. Beautifully illustrated catalog for only 25c.

## TOP OUT

(Continued from Page 67)

representative to the next Internats to factually demonstrate what's possible? Europe certainly isn't the barren Class I waste pictured by the CIAM action and we may even be pleasantly surprised — if a close look is taken — as to how much really flourishes!

Whatever the courses of action finally chosen, rudderites have emphatically stated they're here to stay as long as anyone else is around. There is no good reason for them to give up their event — as has so far been suggested — as it is for Class III or anyone else to do so. Class I fans, as well as those interested in other events, have the right to be fully represented in spirit as well as in fact — and it has been made abundantly clear that this spirit has not been in evidence so far. As every ex-G.I. knows, you can't fool the troops — not for long, at least!

### WITH THE FLYERS

● Tucson's TRCC "Noise" relays that their club gavel has been passed on to Hank Wright for 1966 from ex-prez Ken McDaniel. Ken, along with Bob Herman, retains his editorial chores in putting their newsletter "Noise" togeth-

er with a smooth and entertaining effectiveness for the 30 members. In addition to such items as R/C crossword puzzles, construction tips, aircraft obituary news, and a traders section, it has a "Tech Topics" segment that goes like this:

*Question: What's the best way to finish an airplane?*

Answer: Fly it!

*Question: How can I insure I won't have interference while flying?*

Answer: Sneak out to the field and leave your wife at home. . . .

*Question: I'm tempted to get started in R/C — what's the best first move?*

Answer: Resist the temptation!

*Question: I'm just starting in R/C and I'm planning to make a "School-girl." Do you think this is a wise move?*

Answer: High school or college?

Bob Angus, top Class I TRCC competitor, added another notch to his collection — this time it was the rudder crown at the 16th Annual Southwestern Regional in Phoenix (Buckeye) Arizona, where the weather was perfect for them all. . . .

● See where the 4th Wright Bros. Memorial R/C Championship is set for June 18-19 in Dayton, Ohio. Don Laughhead (4789 Lamme Road, Dayton) promises: 4 flight lines widely separated, an improved multi pattern and free-style expert fly-off, a large pool of

experienced judges, and coffee and donuts to early flyers. All that's in addition to their prize list which includes TV's, propo and reed equipment, engines, kits, etc., etc.—and those special Wright Bros. desk set trophies! Like all the big ones, superhet or 6 meters only. . . .

● The TORKS of Oklahoma City are cranking up their contest machinery early this year by virtue of cornering the very desirable 3 day Memorial Day weekend for their 1966 bash. Always among the best meets in the country, the TORKS — with Randy McGee in the 1966 prexy chair — are setting out to outdo previous wing-dings. A large turnout is expected for the full range of events and to enjoy the robust hospitality and variety-filled event list for which the TORKS have become known.

● Jackie Gardner phoned to give the dates of the Jackson, Mississippi, contest which has been set for an early 21-22 May. A must for the Gulf area flyers for tuning and trimming their new stuff for the big one in July . . . we're set to try this one with our new PCS equipped bird. Jack also relayed details of his new PENETRATOR — a sure-fire Class I pace setter that already has the King Orange crown hanging on its belt so far this year. The original equipment, reeds and ST 60, were replaced with propo and a Merco 61 after the Miami meet giving added performance and smooth-



# NEW

## SCALE PYLON RACER

1949 WINGWAX    1950 "LA JOLLITA"    1951 SKEETER    1964 MISS SAN BERNARDINO

### "LA JOLLITA"

for *SPORT*  
*Pylon Racing*

### \$29.95

SPAN 45"  
LENGTH 41"  
AREA 460 SQ. IN.  
ENGINE SIZE .29 to .40



95° SCALE

*a Contest Proven Model Design*  
*for the Miniature Goodyear Event*

**R/C BUILDERS DREAM**  
**Fast - Stable - Responsive**

Complete construction kit includes, Selected Balsa Wood and Plywood,  
29 High Impact, weight and labor saving Plastic Parts.  
High Impact Cheek Cows, High Impact Wheel pants, Preformed Metal Landing gear,  
all necessary Nylon control and mounting hardware, Plastic Scale Canopy,  
Small Scale three view of full size airplane and full size Construction Drawing.



6719 SALT LAKE: BELL. CALIF.

er maneuvers, Jack relates. Had little trouble transitioning to the propo, Jack assures. A foam wing has also been installed retaining the thick-sectioned (about 15%), late curving (30-35%), flat-bottomed wing section characteristics Jackie favors. RCM will feature this beauty soon, meanwhile don't drool on the pictures. . . .

● Journeyed to Shreveport where Emily and I were treated to warm hospitality and the sincere friendship of the SHARKS. To top it off, received a permanent membership scroll and gold card. Keith McCoy, SHARKS presi-

dent, did the honors for the 24 member club which consciously goes about making their outfit a real family activity. Emily was thrilled with her gold membership card and came home enthused to promote a similar spirit for our own ARCS. More on the SHARKS visit next month, but in the meantime, much thanks to all the boy and girl SHARKS of Louisiana.

● Glue Dobbers Willard Kehr and Joe Hawkins, who wind the Tulsa club's newsletter, lists their annual (the 18th in case you're counting, they say) contest as for 13-14 August. John Riggs is the new R/C reporter . . . hope to hear from you, John.

● Bob Follette, Port Arthur "Oily Bird" prexy writes that Cal Scully, Norm Rhodes, Bubba Doiron, Lon Betts, and Bob Moore will be putting

their contest together 25-26 June. Good for honeymooners, they say . . . ?

#### A SAFETY WORD

Let's face it - what RC'er, looking at that spinning prop a few inches from his eyes hasn't thought of safety glasses to eliminate the risk? Yet very few of us have taken the move to protect the precious commodity of sight - and thus gamble on having a major personal disaster every time we flip a prop, tune an engine. We all buy lots of liability insurance but isn't it time to do something now to protect you from a 1/4 cent's worth of

*(Continued on Page 70)*



Maurice Woods gives his junior, Bobby, the word at the 1965 TORKS meet. Samspey 404 is an armful for Bob who expects to handle it more easily at the 1966 Memorial Day weekend meet in Oklahoma City.

Bill Hollenbach and Sig Buster team with Controlaire 10 reed gear to lead pylon racing for the San Antonio ARCS. Bill's working on distance record ship to test wide open Texas spaces!



# THE DREAM R/C FOR BEGINNERS AND SUNDAY FLYERS

MODEL R-T FOR MODELS UP TO 52"  
SPAN AND UP TO .19 ENGINE  
DESIGNED BY DICK JANSSON  
SEND 10¢ FOR COMPLETE CATALOG

*Proportional Rudder  
with Throttle  
Control*

(Throttle escapement not supplied)  
**COMPLETE SYSTEM**  
(less transmitter batteries)

**\$125**

## NEW! SUPER-HET PROPORTIONAL COMMAND MASTER R/C SYSTEM

**TECHNICAL SPECIFICATIONS TRANSMITTER RT-1.** 5x7x2½. All Transistor single tone AM Modulated Relayless Pulse, uses unijunction and silicon transistors throughout. Battery: 9v. Pulse width: 4 PPS—Rudder; Pulse Rate 12PPS—Throttle; 3600 Cycles Per Second Audio Tone Frequency; Center Loaded Half Wave—54" Antenna, Power Output 225 milliwatts. Range: as far as visible.  
If purchased separately \$49.95

**RECEIVING UNIT RT-1.** 1½x2x4. Super-Het Crystal Control, 5 Transistor Relayless Circuit. Audio Tone Selectivity: 3600 C.P.S. Thermal Stability from 0 to 140 degrees. Built-in 9.6 Nicad Battery. Decoder Board, rudder-throttle type, 6 transistor, pulse width rate. Powerful double coil magnetic actuator, with built-in magnetic centering.  
If purchased separately \$79.95

**MAGNETIC ACTUATOR** If purchased separately \$6.95

**CHARGER**—Isolated transformer type charger for 9-volt 250 mil. Nicad batteries.  
If purchased separately \$4.95

**UNIVERSAL TORQUE ROD CONNECTORS**—Molded nylon, friction free, electrically isolates torque rod.  
If purchased separately 3 for \$5.00



By **Sterling**  
**MODELS**  
BELFIED AVE. & WISTER ST.  
PHILADELPHIA, PA. 19144

- 1. JUST STRAP IN AND FLY.** No wiring! No Soldering! No technical knowledge required! Switch, batteries, receiver, actuator, etc. pre-wired and housed in a single compact unit ready to strap in and fly!
- 2. STEER NATURALLY.** No button-pushing confusion! Proportional control makes flying a pleasure, with no "button-tension." Simply move the control-lever in the direction you want to fly.
- 3. NO "ABORTED" FLYING DAYS!** Now when you want to fly—you fly—because your Command Master is the product of the latest proven electronic developments, utilizing the finest components available today.
- 4. NO MORE CRASH-RUINED EQUIPMENT!** The Lexan housing of the Command Master receiving unit is virtually indestructible. Compartmentalized triple modular design for maximum safety.
- 5. NO INVESTMENT LOSS!** Your Command Master is a basic R/C building block. Additional factory-installed controls (elevator, aileron, etc.) may be added to match your advancing flying ability.
- 6. NO EXPENSIVE "EXTRAS" TO BUY!** This receiving unit is truly complete. It even includes built-in rechargeable Nicad batteries and the charger. Just plug it in the night before—and fly!
- 7. GUARANTEED FOR 5 YEARS EVEN IF IT CRASHES.** No more big repair bills! No more lost flying time! Immediate replacement will be made on receipt of the unit at the factory with \$7.50 provided the lid is not removed and unauthorized repairs are not attempted.

## TOP OUT

(Continued from Page 69)

runway cracked nylon or wood that can quickly bring about a tragic accident? Don't gamble any longer, protect yourself and enjoy RCing more. Check your local optometrist or industrial safety supply house — protection is cheap, convenient (they're good sunglasses), and useful for other purposes. Don't put it off — and let's bring an end to this danger right now before it's too late! One major accident, caused by this very factor, happened just last month. DON'T let it happen to you!

### CONTEST TECHNIQUE

The Cuban Eight — it has been suggested it be called a Horizontal Eight — is the next maneuver of the standard pattern which may be performed by rudder-only controlled aircraft. Since sustained inverted flying trim is not presently possible the four-point roll and outside loops have been passed over and we're now ready for these back-to-back loops. With the latest rule changes, the maneuver starts from level flight, loops over almost three-fourths of the

way around, a half-roll to finish the first side and to bring the aircraft into a 45° dive attitude, then another loop ended by another half-roll crossing over the same point the first roll occurred and finishing the job with a pull-out at the same altitude and direction as the entry.

For Class I this maneuver is done cross-wind, that is, the plane of the loops will be 90°, or perpendicular, to the wind. This positioning is necessary to make the loops symmetrical, or even,

"Oily Bird," held by Wayne Moore, is Class I creation of his dad, Bob, secretary of the Port Arthur R/C mob. Ship performs well and is first of several to be seen in contest trials this year. Club will sponsor all events meet 25-26 June.



on both sides. And here's an important part — the half-rolls being of the 'barrel' variety will 'dish' the aircraft in such a way as to off-set drift. That is, if you roll in the correct direction! Here's how that 'correct' rolling direction goes: Assuming the left loop is the first half done (and the maneuver is being performed upwind where it should be), as the ship is headed inverted into the 45° incline after looping through the 225° mark, a **right** half-roll is executed. Then, on the right side, the second half-roll, prior to completion of the maneuver, is a **left** roll which prevents the loop from drifting toward you.

With the foregoing as a general orientation on special considerations for the Cuban Eight, let's tie it to the pattern that went on before and go through this maneuver start to finish. . . .

In the last maneuver, the Loops — they were completed and the aircraft positioned at about 45° off-wind and approximately 75 feet upwind at an altitude of 75 to 100 feet. Recall, the throttle was retarded and a turn was being executed to place the aircraft 90° to the wind and heading to a point directly upwind about 100 feet from the transmitter. After the turn is complete stabilize the altitude by adding power and continue in level flight to a position just past the point directly upwind. Now advance the throttle to full and

## The BABCOCK BC-21 System

Complete system:  
**\$39.95**

- The lowest priced interference-free single channel system on the market today.
- Provides selective rudder plus up-elevator from a single escapement.
- Designed for the smaller models, but adequate up to .15 size.
- Complete system includes transmitter, receiver, escapement, battery clip and switch panel.



## The BABCOCK BC-22 System

Complete system:  
**\$59.95**

- Provides proportional rudder-only control from an exclusive new magnetic actuator design.
- Right and left buttons for "full-response" rudder-only stunting.
- Designed for models up to .07.
- Complete system includes transmitter (built-in pulser), receiver, PA-9 proportional actuator, battery and switch panel.



## The BABCOCK '27' System

Complete system:  
**\$79.95**

- The maximum amount of control available to the single channel flyer. Provides selective rudder, selective elevator, plus motor control.
- Pilot stick control eliminates push-button flying.
- Completely pre-wired and cabled, and includes torque rods in place and stubbed out. Universal joint couplers provide "bind-free" torque rod operation.



- ✓ Standard 9-volt transistor radio batteries used throughout
- ✓ A new concept in superregenerative receivers — interference immunity from Citizens Band operation due to the extremely high selective audio frequency of 6000 cycles
- ✓ No FCC license required . . . you save \$8.

## SPORT FLYERS SPECIAL!

LIMITED TIME ONLY

**FREE COX .020 ENGINE**

AND FULL SIZE

**D.Q.A. 704 PLANS**

**WITH ANY SYSTEM PURCHASED**

A DRY-CELL BATTERY CHARGER FOR CHARGING THE 9-VOLT TRANSISTOR RADIO BATTERIES USED IN THE BC-21, BC-22, AND '27' SYSTEMS PROVIDES UP TO TEN TIMES NORMAL BATTERY LIFE.

— \$4.95

**ACT NOW! Offer Is Limited!**

Send cash, check or money order.

California residents add 4% tax.

**BABCOCK CONTROLS INC.**

P. O. Box 666

Laguna Beach, Calif. 92652

simultaneously kick the ship into a sharp 180° dipping turn. (Get in the habit of making this turn nose to the wind — it will keep the ship from drifting back.) This will put you at the starting point and also set the cross-over point where the half-rolls should be done for top scores. Quickly call the maneuver and concentrate on keeping the nose 90° to the wind line and the wings even. Loop up and over — throttle constant — and before the plane starts to tuck under, but with the nose well down, execute your first roll. Remember now, which way — left loop gets a right half-roll and the right loop finishes with a left half-roll. The timing of this first half-roll is important, too. That is, the roll rate as

well as when it's done — these should be such that the second loop will bottom at the same level that entry was initially made.

Now you've got nothing to do except keep her straight with wings even and let the bird loop up into the other side. Especially keep your course 90° to the wind, and once past the top and started down half-roll gracefully (remember which direction?), chop the throttle — some chop it prior to the second roll which is OK — and as she bottoms even with the starting altitude call "Maneuver complete!"

Relax a while now — the spin comes next time!

## CLOSING SHOT

A recent letter from the Port Arthur R/C Club P.S.'d this thought: "The Oily Birds would like to congratulate Mr. Jerry Jackson on his good luck in catching such a pretty wife. He had better treat her right or he will have to answer to us next time we see him. . . . (Which only proves RC'ers take care of their own — especially the pretty ones.)"

## HOUSTON PLANS MODEL PORT

Ron Beard, Greater Houston Aeromodeling Council, forwarded a plan of Houston's model airport, scheduled to be started soon. It's an imposing complex, featuring a complete array of sporting facilities, and reflects a serious attempt to solve several problems that plague modeling.

Jerry's diagrams and monthly commentary on Class I maneuvers can help you become proficient in this challenging aspect of R/C competition.

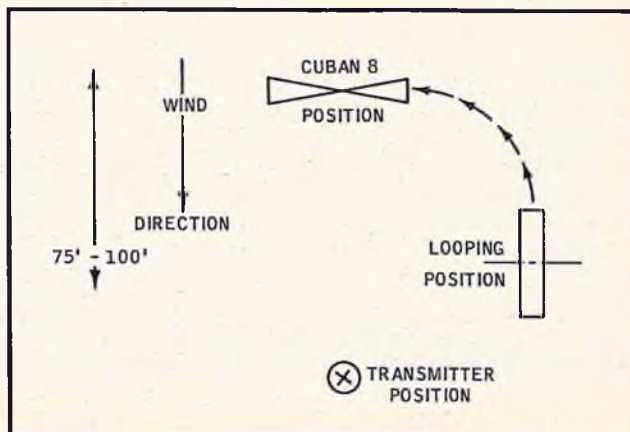
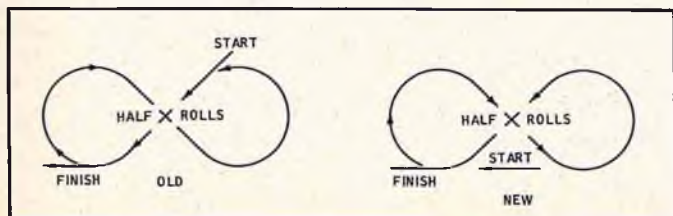

# CITIZEN-SHIP AP PROPORTIONAL

**SINGLE**

OR DUAL STICK



**LOWEST PRICE IN THE WORLD. WRITE US.**

So many of our mail customers have asked us to do the hook up and supply the nicads and chargers, we felt we should advertise this deal.

Citizen-ship AP or APS single stick system, transmitter, receiver, 2APC, 1 APM servos, switch and hook up board	<b>LIST PRICE</b> <b>\$249.95</b>
2 packs of 4 500ma high rate nickle cadmium button cells, in pack form, tapped and wired	<b>\$ 24.00</b>
1 nicad charger	<b>\$ 7.95</b>
1 9-volt cell for transmitter	<b>\$ 1.95</b>
Hook up and check out of entire system includes, soldering of plugs to wires, packs to plug, extra connectors for charger to pack charging connection, check out and charging instructions	<b>\$ 10.00</b>

**VALUE \$293.85**

COMPLETE, READY TO FLY (Just turn on switches)

**HOBBY LOBBY PRICE \$199<sup>95</sup>**

Same day service, these hooked up systems are IN STOCK!

**Amazing Prices on Digital Proportionals !!! Write Us.**

Satisfaction guaranteed or money refunded. We pay postage on all orders accompanied by check or money order.



2604 FRANKLIN ROAD (RC) NASHVILLE, TENN.  
Area Code 615-297-9127



Store hours 10 A.M.-6 P.M.  
except Sunday

coverage on the show, so I'll stick to the items most closely associated with our Sunday flier type activities. Except, I do want to say, right off, that the entire event was handled excellently! The Weak Signals Club is to be congratulated on staging the finest Conference ever presented, and special mention must go to Ken Borrer for his untiring efforts — along with Tom Dion, Walt Reissig, and all the others. Terrific show! They had over 1200 paid attendees on Saturday (women and children were admitted free) and so I would estimate that, counting exhibitors, guests, etc., there were about 3,000 people there on Saturday, and although I didn't hear the figure for Sunday, it must have been very nearly the same. In other words, over 5,000 people for the two days! Look at the crowd in the lead photo — and that was on Sunday, after it had "thinned out."

As usual, I zeroed in on the guys with radio gear for small models. First, there was the improved Miniplex equipment. Their experience during last year indicated that mounting the servos and the receiver in one unit led to vibration and interference problems, so in addition to some changes in the unit, they separated them. Photo #1 shows the uncovered receiver with the servo, battery pack, and transmitter. The all-up weight stays the same—8½ to 11 ounces, depending on the type battery used.

Next, there was Rand Manufacturing's "Take Off" products. Their little unit, the LR-3, is very ingenious, making use of the Galloping Ghost principle, and at 1¼ ounce weight, is less than the weight of two escapements. It does require a relay receiver for operation but is excellent for ½A operation, and the thrust appears to bear out their claim for enough power to handle a .35 powered model — although I'd be a little cautious about it! Picture #2 shows a typical installation.

The third unit in the competitive series is another newcomer — Airtrol. Their RE-1 set includes everything needed to fly, and the airborne equipment, with superhet receiver, weighs 6 ounces! Light enough to go in a ¼A (.020) model. There's no engine control, but then, neither does the Cox .020 have a suitable throttle, so you don't really need this feature. Look at this proportional setup in pic #3.

(Continued on Page 74)

(Continued from Page 72)

**NOW**  
WITH THESE  
HAND-CRAFTED  
PRE-BUILT  
R/C MODELS

you can enjoy your hours flying, rather than building! These precision crafted, pre-built American Products planes arrive with the wing panels already joined and fiberglassed. Strip ailerons, rudder, and elevator controls all are hinged. All you do is install the engine, controls, tank, and wheels . . . and start flying! These are not kits. They're already built of the finest balsa, plywood and foam. Painted fuel-proof white or brilliant orange as you specify and ready for your personal trim. Average flying weight with your .45-.61 engine: 6 or 7 lbs. Sold factory direct only. Order today or write for more facts.

**HAWK** shoulder wing model is built for the novice or "Sunday flyer." Has 64" wing span. Semi-symmetrical airfoil. Includes main gear and Tatone nose gear/engine mount. A real stunter at full power, but tame and gentle when throttled back.

\$75

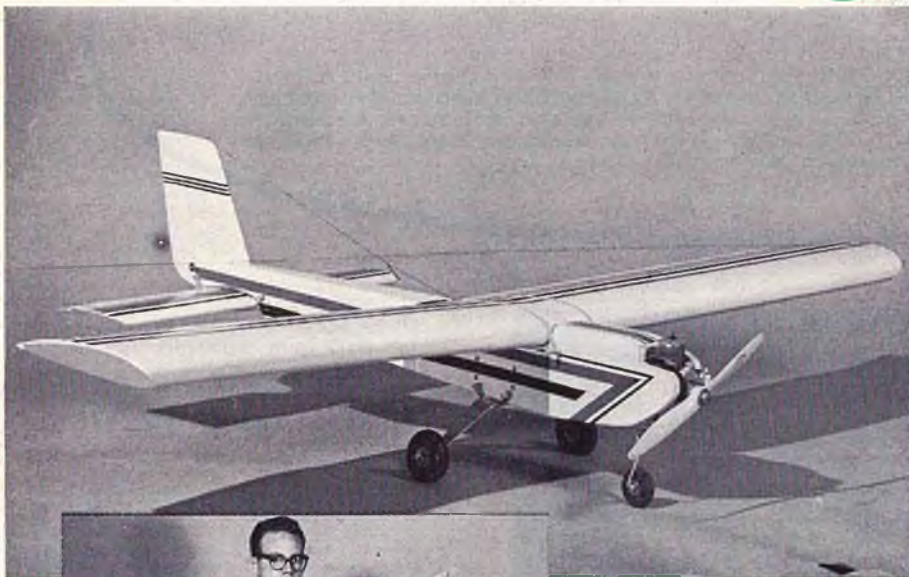

MEMBER, KANSAS STATE CHAMBER OF COMMERCE

**TEMPEST** low wing is designed for the "pro" who enjoys contest flying. Performs full AMA stunt pattern. Smooth tail down landings. 66" span. Full symmetrical airfoil. Includes Tatone nose gear/engine mount, formed main gear, gear blocks installed, and canopy.

\$85

R/C Models Division **AMERICAN PRODUCTS, INC.**



Telephone (316) DU 5-2650 Spearville, Kansas

**R/C Models Division, AMERICAN PRODUCTS, INC.**  
Spearville, Kansas 67876

Enclosed is my check for \$ \_\_\_\_\_ . Please send the following R/C Models:

\_\_\_\_\_ American Hawk @ \$75.00    \_\_\_\_\_ American Tempest @ \$85.00 Ship rail express collect to:  
 Orange     White     Orange     White

YOUR NAME \_\_\_\_\_

ADDRESS \_\_\_\_\_ CITY \_\_\_\_\_

STATE \_\_\_\_\_ ZIP \_\_\_\_\_ PHONE \_\_\_\_\_

Kansas residents add 3% sales tax. Attach check or money order.

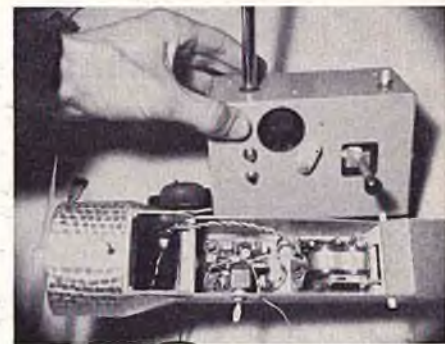

Well, from my standpoint, those were the three most interesting items of radio equipment - small, light, and easy to install. Easier, in some respects, than escapements. Incidentally, no escapements were on display except for the motor control element in Sterling's Command Master system. Sterling's idea is good, but the unit is too big and too heavy for the model sizes I prefer.

In the near future, I plan to get some flight time on these new developments in, as Herb Abrams of Rand puts it, "Gallop-less Ghost." The results should be interesting.

In the airplane line, some new trends are showing. I refer specifically to the "ready-to-fly" class. Top Flite showed a prototype low-wing that they are thinking about - 1/2A power, 42" span. Although it's nice looking, it didn't get much attention as their new covering, Monokote, stole the show as it did at Garden Grove!

Lanier Industries showed their big jobs - but again, I'll let the big plane men talk about them. In the small model field, Myers Models showed their 36" span "May Fly." This is a very nice looking, conventional type high wing, with a variation called the "Sweet Pea" as a parasol configuration. These models should be good sport models for testing and flying the small proportional rigs mentioned earlier. Also, they can be bought as partially completed kits, rather than as ready-to-fly, if you prefer to finish them yourself and save a little money in the process.



(Continued on Page 76)

## FOAM WING CORES

SOLID EXPANDED BEAD FOAM  
(VERY LIGHT WEIGHT)

**\$7.50** SET

FOR: TAURUS, JENNY, FALCON 56,  
INTERCEPTOR, HAMMERHEAD, CANDY,  
NORSEMAN, KWIK FLY, PHOENIX,  
or send us your Paper Patterns and  
desired span up to 80" and we will custom  
cut your cores for the above price.  
(Double for Bi-Planes)

**Phil-Nick Hobby Supply**

P.O. BOX 84  
OAKS CORNERS, N.Y. 14518



**YOU  
ALWAYS WIN  
WITH  
WORLD WIDE**

Get the latest and greatest. Be sure you are  
getting your free copy of "Quick Blips" from:



**RADIO  
CONTROL**

7845 Wyoming, Dearborn, Michi 48126

## SUNDAY FLIER

(Continued from Page 74)

Airtrol, in addition to their radio gear, displayed a simple, semi-profile type model which they tentatively hope to market, ready-to-fly **including** radio equipment installed! To be perfectly honest, it didn't appeal to me — it was a little **too** simplified. But who's to know unless you try it. At any rate, it looks like a lot of people think there's a good potential market for ready-to-fly radio controlled airplanes.

One of the most interesting developments at the show, yet the least noticed in some respects, was Cox's new Quiet Zone engine. The reason it wasn't noticed was because it's so darn quiet! They ran it right in the auditorium and nobody heard it!

Now this gets very interesting to you and me — **and** a lot of U-control enthusiasts. Engine noise has chased many modelers away from flying sites where they could fly except for the racket made by the exhaust. Oh, there are other considerations, to be sure, but they wouldn't have come up had it not been for the noise in the first place. But for 1/2A R/C and U-control enthusiasts, the Cox QZ could lead to the resumption of flying in areas where it is now prohibited, if a careful demonstration is made to the right people. Schoolyards, now banned, could be used again, in many cases through "re-educating" the school board or principal with a **quiet** show.

Cox's muffler on the .049 is unusually efficient. Sure, there's a loss of power, but it's very small compared to previous attempts. Just putting the housing around the cylinder causes a drop, as it was explained to me by Dale Kirn, of about 2% in RPM with the muffler valve open and the engine running noisily. Then when the valve is closed, there's another 2% drop. 4% in all — with no noise!

But here's a big point. Cox re-designed the innards of the cylinders and piston, and if you took a standard Medallion, for instance, put one of the new cylinders, pistons, and muffler combination on it — you'll wind up with **more** RPM than the original Medallion! True, you could get even more without the muffler, but if you've been flying with a Medallion, you won't need it, and you're running quiet to boot! I don't know about you, but I'm very impressed — and now, when I fly locally, I don't think anyone will comment on the noise. You'll hear more about this development, I'm sure. For the "acid test" I ran mine early Sunday morning, and the neighbors didn't even hear it! Also, it starts easily even in the muffled position.

*Beating to Windward, on a  
Starboard Tack —*

## NEW FROM DUMAS BOATS

### 45" RADIO-CONTROLLED STAR CLASS SAILBOAT

*All the Thrills and Skills of  
Sailing Big Boats*

- ★ 1/8" birch plywood hull  
with die-cut frames
- ★ Mahogany deck
- ★ 64" high spruce mast
- ★ Ready-made sails
- ★ Instructions for building boat,  
sailing boat, installing RC equipment,  
and Forms for making your own ballast.

a Star Sailboat  
for racing —  
slightly modified for R.C.

**\$45<sup>00</sup>**

## DUMAS

featuring the "hot ones"  
designed for "go" . . . ideal for show

**BOATS** Dept. RJ  
P.O. Box 6093  
TUCSON, ARIZONA 85716

*satisfaction  
guaranteed.  
immediate  
delivery*

*dealer inquiries  
invited*



WRITE FOR  
FREE CATALOG  
over 30 boats  
including the  
Historic  
PT 109, the  
Gold Cup  
Hydroplanes,  
& Skaddle  
models of the  
famous  
Rich Hallett  
"SK" boat

Back to the other show items. Bob Hall showed some interesting tempered aluminum, shaped landing gears with integral lock nuts for mounting the wheel axles. Real time-savers, and available in maroon, black, and natural aluminum.

Hans Graupner, with his associate Fred Militky, the small electric motor specialist, was there — all the way from Germany! They had one of their beautiful big gliders on display, but were intrigued with the "Top Dawg's" small size and roomy radio compartment — so naturally I took a picture of them with the model.



So, back to more interesting pursuits. Gotta get those plans in so you can start building. Next month for sure. Promise.

## PIFF

(Continued from Page 22)

small holes in the plywood pads for thread or #22 copper wire. Hysol's Epoxy patch will make it one unit. Keep the pads level by putting a straight edge across them from R to L until the epoxy starts to cure. When the epoxy has cured completely add  $\frac{1}{16}$  plywood to the top of the  $\frac{1}{8}$  pads, to cover the gaps. Round off the leading and trailing edges and sand the tops to get a more perfect fit for the upper wing. The cabane is finished except for the  $\frac{3}{8}$ " x  $\frac{1}{8}$ " Balsa struts. Sand grooves to fit the wire. Also sand the radii and glue to wires with Dart glue or Ambroid. Then silk later.

Now you can fill the holes in the plywood doubler with epoxy, making sure that the epoxy flows down, in and around the cabane struts. They will never come out now.

### HATCH CONSTRUCTION:

You may have your own way of making a hatch, but this one isn't too difficult. Using the 3 tops of F1, with  $\frac{1}{4}$  square holes, cut out of the top and sides, make the hatch frame. Place the front hatch former back a little to allow for the "L" bracket and screw hold down. Adapt the middle former to your R.C. equipment. The rear hatch former is  $\frac{1}{8}$ " forward so as to make up to the F1 top, F2 combination. Glue F1

(Continued on Page 78)



## Around the World "Speedy" Mail Order Service

### NEW PHOENIX

FIBERGLASS  
FUSELAGE

Send for  
information and list of  
specials —

ONLY \$27.95

COMPLETE RADIO CONTROL BOATS AND AIRPLANE SUPPLIES  
**ORANGE BLOSSOM HOBBIES, INC.**

1975 N. W. 36TH ST. - MIAMI, FLA. 33142

We pay Postage on All Orders Over \$5.00 in U. S.  
Florida Res. add 3% state tax. Send check or M.O.

### A Ready to use Single Channel "System"

Now you can buy a Single Channel system you can afford \*it works right out of the "box" \*all prewired with switch and plugs installed on receiver, servos and battery pack \*packaged just like the expensive proportional systems \*in this system we use the World famous Controaire Mule 11 Transmitter and receiver (available superhet or regen), Royal or O.S. servos (your choice) and ANDY's prewired harness assembly pictured in this ad.

Drop us a card or letter for more information and prices on our single channel "Systems" \*We will also send you a copy of our "BEST BUYS in R/C" price sheet. \*We will gladly answer any questions you have on any type of R/C equipment, engines, kits, etc., to the best of our ability.

Another first at ANDY'S R/C is the "LUCKY R/C BARREL NUMBER" each order we receive is given a "LUCKY BARREL" number. Once every 90 days we draw three numbers, each of these customers receive a free R/C gift. These items are R/C kits, engines, equipment and hardware with retail values up to \$35.00.

NOTE: Wiring harness assembly shown above, sold separately to use on your own single ch. equipment. Prewired with instructions \$5.95.

Check our ad in March Issue of RCM for Galloping Ghost Sys. page 52.



This single channel system is ready to go — just turn on the switch and "fly"

**ANDY'S RADIO CONTROL & HOBBY SPECIALTIES**  
P. O. BOX 484 SUNNYSIDE, WASHINGTON

## Mister E

BY

50" W. S. PYLON-TYPE SPORT  
RACER DESIGNED FOR  
MAXIMUM PERFORMANCE ON  
MINIMUM EQUIPMENT

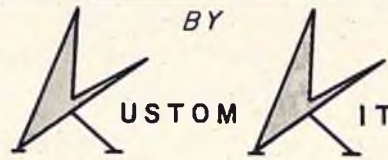

CUSTOM KIT

FOR .09-.10-.15 POWER



Wheel Parts  
Not Included

DELUXE KIT  
\$12.95

AT DEALERS

OR DIRECT FROM

P. O. Box 2555, Schenectady, N. Y. 12309

## CHEROKEE

Full Length Die Cut Sides

\$26.95



WING SPAN 65"  
POWER .40-.51  
FLYING WGT. 6 1/2 LBS.

Challenger  
\$21.95

KIT INCLUDES  
OUR OWN COIL SPRUNG  
STEERABLE NOSE GEAR

WING AREA 754 SQ. IN.  
AIR FOIL 18% SYMMETRICAL  
RADIO - MULTI-REDS or PROPORTIONAL

### ACCESSORIES

(AVAILABLE SEPARATELY)

STEERABLE  
NOSE GEAR  
ASSEMBLY \$3.25

DURAL MAIN GEAR  
(HEAVY DUTY  
WIDE TREAD) .090" THICK \$1.95

**VK MODEL AIRCRAFT CO.**

4350 ARONDALE DR.,  
WILLIAMSVILLE, N. Y. 14221

# — READY TO FLY —

## FLY 5 MINUTES AFTER RECEIVING

TO FLY, RUBBER BAND WINGS & TAIL ASSEMBLY & WHEELS,  
PUT GAS IN TANK, TAKE OFF.



### SPECIFICATIONS:

1. 100% COMPLETELY BUILT.  
(No Extras To Buy)
2. RADIO  
(Citizenship Analog Proportional)
3. .45 ENGINE (Enya)
4. COMPLETELY PAINTED
5. 8 RECHARGABLE BATTERIES
6. TRIMABLE ENGINE SPEED
7. PROPORTIONAL RUDDER, ELEVATORS  
WITH TRIM AND STEERABLE  
NOSE GEAR
8. 8 OZ. FUEL TANK
9. FIBER GLASS FUSELAGE
10. FOAM CORE WINGS
11. ALL PLANES WITH RADIO  
EQUIPMENT, TEST FLOWN
12. 69" WING SPAN (810 Sq. Inches)
13. 6½ LBS., READY TO FLY
14. ALL PLANES SHIPPED  
EXPRESS COLLECT

**TEMPORARY INTRODUCTORY PRICE — Complete Ready To Fly**

(NOTHING EXTRA TO BUY) **\$299.50**

Buy Airplane Only \$99.00 and Receive FREE, .45 Engine (\$24.95 Value) & Gas Tank.

## LUNDCRAFT INDUSTRIES

14450 SOUTH KILPATRICK  
MIDLOTHIAN, ILLINOIS 60445

### Buy Your Transmitter or Receiver WITHOUT NICAD® BATTERIES

Build your own power pack with our SINTERED PLATE SEALED NICKEL CADMIUM cells with solder lugs and save up to 50% — all you need is a soldering gun and a roll of tape.

#### A SPARE BATTERY INSURES A FULL WEEKEND OF FLYING

Button Cell Batteries

Dimensions	Voltage	Capacity	Price
1.6" x 1.4"	4.8 volt (2.4 volt tap)	600 mah	\$9.95
1.1" x 1.4"	4.8 volt (2.4 volt tap)	300 mah	\$6.95
2.8" x 1.4"	8.4 v. (6.0 & 3.6 v. taps)	600 mah	\$19.95
2.0" x 1.4"	8.4 v. (6.0 & 3.6 v. taps)	300 mah	\$11.95

Use the above packs with Citizenship, Bonner Digi-mite, F & M, EK, etc.



Take the NICAD story to work with you tomorrow. Show your purchasing agent, chief engineer, supervisor, etc., how he can save money and reduce battery replacement problems with our cells. If you or your company want more information — write us with a stamped self addressed envelope — if we can't help you, **NOBODY CAN!**

Nationally Distributed by

**POWER INCORPORATED**

P. O. Box 132, RCM8

Minneapolis, Minnesota 55440

Sponsor of trophies in the 1965 National Model Airplane Championships at Willow Grove, Pa.

- Tested, approved, and recommended by R/C Modeler Magazine.
- Used by quality manufacturers such as Orbit, Kraft, Sampey, etc.
- Proven most popular at the R/C National Championships.
- Factory Fresh.

**NEW POLICY** — We encourage R/C club and AMA membership by offering a 10% discount from our list prices to members.

Cylindrical Types with Solder Lugs		
Capacity (Mah)	Type	Price
500	500SCL Pencil	\$2.10
600	600SCL Oversized Pencil	\$2.21
1200	1.2SCL Sub "C" cell	\$2.85
1250	1.25-D "D" cell	\$3.00
4000	4.0SCL "D" cell	\$6.00

Button Types with Solder Lugs		
Capacity (Mah)	Type	Price
500	500BHL (high rate)	\$2.10
450	450BL	\$1.75
225	225BHL (high rate)	\$1.45
225	225BL	\$1.05

Orders under \$15.00 add 50c, over add \$1.00 for postage and handling. All packages sent 1st class mail for safety and speed.

Hundreds of other sizes available — cells and batteries — write us if you don't see what you want.

## PFIFF

(Continued from Page 77)

top former to F2 with ¼ clearance all the way around. This will provide a step which the hatch will fit. Put peg in F2, a hole in the rear hatch former will pick up this peg when you slide the hatch in. Then rubber bands or hooks will not be needed to hold the hatch down. Cover the hatch like the turtle deck.

Adapt the second unmarked former in the fuselage to your tank and battery requirements.

Use ¼ hard sheet or blocks to build up the nose, altered of course, for your particular engine. The nose blocks should be ¼ higher than the round top of F1 so as to be flush with the hatch when it is in place.

When you have the R.C. equipment in, including the pushrods or torque rods, sheet cover the rest of the bottom cross grain. It seems that if you put in all the dowels and the tail wheel you are over the bump.

### STABILIZER:

The stab is a breeze. Lay out the entire frame for the stab all at once, tips, center section, leading edge, trailing edge and then glue. While the glue is drying, mark off the stations for all the cap strip ribs. This is also a good time to cut out the rudder, fin and elevator halves. Might as well glue the elevator together because the tail is almost finished. Oh yes, have you also glued in the ¼ x ¼ strip? They go in the center on the inside of the leading and trailing edges. While they are drying, get the ¼ x ¼ strip stock and cut the strip ribs to size, right on the stab. Hold one end of rib down at T.E., bend over spar to L.E., cut with a razor blade and make two each time.

Now take the stab off the plans, have 16 spring type clothes pins ready, a little dab will do ya, glue, i.e., on the rib stations, top and bottom. Install the strips, top and bottom, two at a time, hold with one clothes pin for L.E. and one for T.E., then just keep going. Now it is finished. Mine took about 1½ hours from start to finish.

Carve the balsa blocks used for the fin supports. They are sufficiently strong to support the fin in the roughest landings. Glue the fin and blocks to the stab. Sand leading and trailing edges of the stab, fin, elevator and rudder as shown, then the tail is ready to be covered.

### WING CONSTRUCTION:

There are no unusual features in the wings. I used the NACA 2412 because it provided enough thickness to keep the Bipe slow, yet have plenty of lift. It has acceptable stall characteristics, because we are able to get a tail slide



(not perfect) on escapements. I wasn't able to purchase a preshaped L.E. to match this section at  $7\frac{3}{8}$  chord, thus the shaved  $\frac{3}{8} \times \frac{1}{2}$  L.E. stock. I know these wings are rugged because I cartwheeled this model several times on landings and they held together just fine. There are 33 ribs and 22 of them are identical. The other 11 vary slightly due to the sheeting differences between upper and lower wing center sections and difference in spar thickness, where the plywood dihedral braces appear. Make aluminum rib templates, to aid you when cutting the ribs.

Now with all the wood cut and L.E. shaved, remember, Bipes don't like warps so don't build any in. First glue all the dihedral braces to the spars, leading and trailing edges, being sure that they all line up with the  $4\frac{1}{2}^\circ$  angle on the plans.

Construct the center section first. Pin the T.E. down flat and with the ribs on the spar not glued yet, insert them into the T.E. With some  $\frac{1}{16}$  stock, prop up the L.E., now glue the ribs in. Be sure the spar is parallel to the L.E. and T.E., then glue it also. Next, the  $\frac{1}{8}$  and  $\frac{3}{16}$  spar, then when that is dried, pin and glue the sheeting on it and wait until it all is well dried. Half an hour will be sufficient if you use white glue. Apply glue to the shaved leading edge and the tops of the four ribs (center section), then clamp the sheeting to the leading edge. When this has set, you will have a very sturdy center section which will hold the wing panels true.

Except for sliding the ribs in place on the remaining wing panels, the construction of the right and left panels is essentially the same as the outline for the center section. Just pin down the trailing edge of the panel you are going to finish, prop up the leading edge, then follow the same procedure as above. Use an aluminum template to aid you when you carve and sand the leading edges.

I mentioned before that Bipes do not like warps, so I will endeavor to point out briefly how warps occur and how to build a truer wing. I have read many construction articles by many modelers, but I cannot remember anyone offering any solutions for eliminating warps. Maybe they all assume everyone else is an expert. Not so, just look at the guy who is having trimming problems with his very simple model, he seems to be in a majority around my neck of the woods.

Warps are caused by internal or external stress in the wing. By internal, I mean the wood itself, those spars that had small warps to begin with. The twisted leading or trailing edges that you forced to be straight pinning or clamping when you are building a panel. The spar you bent up, down, or sideways to go through the misplaced hole

(Continued on Page 80)



Fine as a Free-Flight . . .  
Thrilling Sport with Radio . . .

FLY HYDRO: Lakes, Ponds, Bays, Rivers . . . Don McGovern's

**Jetco**  
MODELS

# NAVIGATOR

## Amphibious Flying Boat



Kit No. RC-5  
**\$10.95**



52" Wingspan  
.049 to .099 Free-Flight  
.074 to .10 Radio Control



Its home is the blue water. Designed for it! An N.A.C.A. Long Planing type hull design, with engine set high overhead in a nacelle. Stays dry in normal landings, and unlike converted free-flights, flying boat types seldom upset on the touchdown. The "Navigator" is a beautiful, graceful capable aircraft, stable on water, on the climb, glide and landing. A roomy fuselage for radio installations, access through top of the cabin. R/C electronic equipment is fully waterproofed when shrouded in Saran-Wrap. Operate in salt or fresh water.

Run your engine dry at end of the day, lubricate it inside and out. Fly it free-flight or by radio, either way. Rudder only, to keep it light and simple. Thrill to the sight of a wide-open seaplane racing across the water, lighter on the step, then airborne and climbing to a speck. Guide it in for a liquid landing, a thrilling sight to see. Wing floats are removable for land flying too, & plan shows how wheels may be installed for amphibious operations. Fly on a bay, lake, pond or puddle. No flying field? Summer coming? Seaplane?

C A ZAIG CO. INC., 883 LEXINGTON AVENUE,  
BROOKLYN NEW YORK

See your dealer today for these and other fine Jetco kits of all types. If no dealer is convenient, send us 25¢ additional, and your mail order will be filled direct.

NO  
FIELD  
TO  
FLY  
ON?

## Will You Miss an Issue of R/C Modeler?

You Will After Jan. 1 if your address label  
doesn't show your proper Zip Code No.

Check Your Address Label Now! If no Zip Code is  
shown, or if shown incorrectly, please notify our  
Circulation Department AT ONCE!

## R/C Modeler Magazine

P. O. Box 1128

Laguna Beach, California 92652

## AIRTROL CHAMELEON I

This equipment is so named because it can be changed into many different control systems. For the rudder only fan, there is a special two-stick transmitter to give proportional rudder and simultaneous proportional engine control with the use of two spring centered proportional servos. For the flyer who wants to build his system as he learns to fly it, he starts with CHD I multi-transmitter, decoder, receiver (regen or s.h.), battery pack (pencell case or nicad), and one proportional servo and one positional servo, and you have rudder only with positionable engine control system. Then add a servo to give elevator, then another servo to give aileron control (ailerons electrically coupled with rudder). Also possible, steerable nose or tail wheel operated from rudder servo, brakes operated from elevator servo, bomb or parachute drop operated from engine servo, etc., etc., etc.

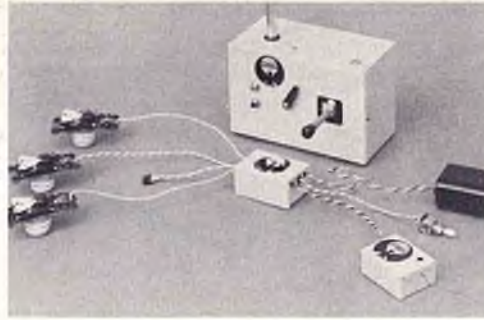

Transmitter has about 150 MW output, with tone frequency of about 800 cps. Antenna is 56", center loaded and collapses to 13". Single stick dual transmitter gives rudder, elevator control with two push-buttons for engine control, and trim control for elevator. Transmitter and pulser are all transistorized, and both operate on one 9 volt battery.

Total flying weight with s.h. receiver, 4 servos, 600 ma pack: 16 oz.

- CHRE I Set (CHRO I Transmitter, decoder, 2 proportional servos, 6 penlite battery case, s.h. or regen receiver).  
 s.h. set .....\$149.95      regen set .....\$137.95
- CHREE I Set (CHD I Transmitter, decoder, 2 proportional servos, 1 positionable servo, 6 penlite battery case, s.h. or regen receiver).  
 s.h. set .....\$179.95      regen set .....\$167.95
- CHPC I 6 penlite battery case .....\$ 4.95      CH1200 I MA nicad pack .....\$24.95  
 CH 225 I 225 MA nicad pack .....\$14.95      500 MA nicad pen-light batteries for  
 CH 600 I 600 MA nicad pack .....\$21.95      pen-light case .....\$ 2.10 ea.

(For set price with nicad pack subtract price of penlite case and add price of desired pack.)  
 All orders received without check or money order will be sent C.O.D. For full information regarding Radio Control Equipment, send twenty-five cents with your name and address:

**AIRTROL, 1001 Railroad Ave., Adrian, Mich. 49221**

## MYERS MODELS

**THE MAY FLY IS A READY TO FLY. WING SPAN 3'. ALL Balsa (SIG). WILL TAKE ANY CLASS I EQUIPMENT. VERY RUGGED CONSTRUCTION.**

May Fly is COMPLETELY ready to fly. Just paint and install equipment and engine. Wheels and landing gear furnished.

**19.95**



HAVE MAY FLY

ALSO

WILL FLY

**SHOO FLY** — Big brother to May Fly. Wing span 48". Class I or II ----\$37.50

**SWEET PEA** — A cute 049 size — Ready to fly -----\$22.95

**ALL Balsa MODELS**

**WRITE FOR FREE LIST**

Send Check or Money Order to

**MYERS MODELS**

Stewartstown, Pa.

17363

Add \$1.00 for Handling  
 DEALER DISCOUNT

in the rib. The ribs that were just a trifle too long and you forced them into place. It is these little things that add up to big warps and possibly a wiped-out model. I won't make any points on this one, but cellulose glue joints produce tremendous strains. They vary greatly with the amount of glue. White glue does not have this characteristic, it just joins the wood together.

The external stresses are in the silk and siron that you pulled tighter than a snare drum head on one side of the wing and hardly tight enough on the other. Sometimes, you put on varying amounts of dope and it shrinks unevenly. Incidentally, Butyrate Dope takes about six months to cure, and it gets tighter during that time.

Now for a few hints on making better wings. Notching ribs into the leading and trailing edges will help when you have twisted stock. Leave the small twist as it is, assemble the wing, and later carve or sand the structure true. It is much better to have the ribs slightly loose than tight, so fit them in with a little clearance on at least one end. If you have a spar that twists slightly at the end and which also bends down, don't force the spar to untwist or bend up when you slide the ribs on, rather, make the holes larger or lower or whatever it will take to get the ribs in place without stressing the spar. Make small cleats from 1/8 or 3/16 square stock. Glue them in to make up for the glue area that you cut away to let the spar pass through. Sheeting the top 1/4 to 1/2 chord back from the leading edge also helps in resisting warps. It is worth while to let wing panels set up at least a day or night before removing them from the plans.

It will help in covering to do it in good lighting so you can see the silk grain. When applying the wet silk, gently straighten the grain so it runs along the span and chord, not diagonally. While it is still wet, gently pull out all the wrinkles, looking along the edge, you will see them clearly. It is not necessary to pull it so tight that the structure bows.

Apply 50-50 dope to the outside edges through the water, but do not dope the ribs. Silk the whole structure at one time, it helps to prevent those terrible warps. Let the wet silk dry all night. You will sleep better anyway knowing that the wings will look straight in the morning.

I have omitted discussion of the landing gear and tail wheel because you will have your own ideas about these. You will note the particulars of my gear on the plans.

I suggest that you fibre glass the fuselage. It sure strengthens the front end. I fibre-glassed the hatch also for the same reason. Use light fibre glass cloth on hatch and sides, heavy coarse cloth on the nose and bottom, back to the lower wing leading edge.

In finishing Pfiff, I use two coats of sanding sealer on everything, sand between coats, then cover everything with silk. Seal the wings with dope cut 50-50 and apply with a moderately full brush, slowly, not overlapping too much. If you get a run, turn the wing upside down quickly and brush it out. This method usually seals 99% the first go-around.

Clear dope the wings and use a minimum of color dope on them. Sand between coats and use a heavy coat of sanding sealer for the third coat.

I do not like to see wood on this type of Model, so I color doped the fuselage, then clear doped over the color. Always sand between coats to obtain a well finished model.

#### FLYING:

The first Bipe flew right off the board in October of 1964, with the following setup: 3° down thrust, 3° right thrust, upper wing at 3° positive incidence, lower wing 0°, and Stab 0°, level elevator and straight rudder. The C.G. was at the spar of the upper wing, with the nose slightly down. I recommend that you leave everything as is, even if yours goes to 4 pounds, except the thrust. It was necessary to have more right thrust and we stopped at approximately 5° or slightly more to obtain straight flight under power. Our 3½ pound Pfiff will penetrate a 15 MPH wind. Whether dead stick or low speed, it turns on command going down wind for your approach.

I must admit that I have never flown S.C. with a pushbutton, I have always used a stick box. I think power landings or low level passes on low or medium speed are by far the most impressive, especially when you can see the little pilot in there. If you have been flying for over six months, you can do the AMA pattern on medium speed very easily. Pfiff grooves either direction, in what appears to be a proportional turn. We have done hammer heads, wing over, loops, Immelman, sloppy tail slides, rolls and power landings. I tried an outside loop, and Pfiff will tuck under easily, but I chickened out. You will need to be in medium speed for outside loops and inverted flying. Pfiff will square off a loop also if you are fast enough.

If you don't care for all that fancy stuff, Pfiff is a pleasure to watch just flying around, not travelling at 70 MPH, but at 25 MPH. There is a bit of nostalgia in the air when she is flying up there. I like Bipes. I sure hope you do, or will.

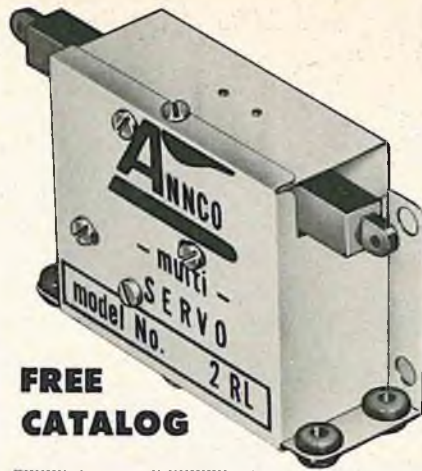

**FREE CATALOG**

# ANNCO

## MULTI-SERVOS

(USE WITH REED RECEIVERS)  
FOR RADIO CONTROL SYSTEMS  
OF R/C PLANES - BOATS - CARS

NOW SAVE DIRECT FROM  
THE MANUFACTURER . . .  
Get All These Big Exclusive  
Features From ANNCO

- **WEIGHT**  
2R . . . . . 1.3 ounces  
2RL . . . . . 1.7 ounces
- **THRUST** Powerful enough for the largest models.
- **TRAVEL**  
5/8 inch straight linear.
- **TRANSIT TIME**  
1/2 second from neutral.
- **MOTOR**  
5 ohm—180 ma no load.
- **BRUSHES**  
97% Silver Graphite.
- **SELF-NEUTRALIZING**  
or can be set up for trim.
- **AMPLIFIER**  
ALL MODEL 2RL SERVOS are equipped with our 7 transistor amplifier (DK-7) that features complete burnout proof operation while adjusting centering, or if adjacent reeds are driven at the same time. DK-7 sold separately @ \$11.95 ea. postpaid.

**MODEL 2R ONLY \$7.95 ppd. (RELAY)**      **MODEL 2RL ONLY \$19.95 ppd. (RELAYLESS)**

#### HOW TO ORDER

Orders will be shipped postpaid within the U.S.A. and Canada (except Air Mail—Add 25¢ each). Foreign Countries—add 50¢ each for regular mail or \$1.50 each Air Mail. **SEND YOUR ORDER TODAY!**

**ANNCO ENGINEERING CO.** 7714 COLFAX AVE. SO. MINNEAPOLIS, MINN. 55423

DEALERS — Write On Your Letterhead For Special Set-Up. Only Bona Fide Hobby Dealers Accepted.

Another DU-BRO R/C First!

## NEW LOW BOUNCE . . . . . SHOCK ABSORBING WHEELS

Introduced and used at the '65 Nationals. Permanently Pneumatic. Same strong unbreakable Du-Bro Dura-Hub.

- 1 3/4" . . . . . \$2.19 pr.
- 2" . . . . . 2.39 pr.
- 2 1/4" . . . . . 2.59 pr.
- 2 1/2" . . . . . 2.79 pr.
- 2 3/4" . . . . . 2.99 pr.
- 3" . . . . . 3.19 pr.
- 3 1/4" . . . . . 3.39 pr.
- 3 1/2" . . . . . 3.59 pr.
- Also available in "SLICKS"
- 2 1/4" . . . . . \$2.59 pr.
- 2 1/2" . . . . . 2.79 pr.
- 2 3/4" . . . . . 2.99 pr.
- 3" . . . . . 3.19 pr.



Regular line of Du-Bro wheels are still available.

Coming Soon . . . DU-BRO INSTANT ACTION ELECTRIC BRAKES

**DU-BRO PRODUCTS** 7667 N. Milwaukee Avenue  
Niles, Illinois 60648

**Record-Breaking Performers  
use . . . OCTURA**



**R/C MODEL BOAT FITTINGS**

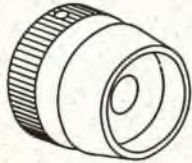

**OCTURA  
MARINE  
FLYWHEELS**

Plated Steel  
Collet included.  
Specify crankshaft dia.

OCTURA 15	1 3/8 x 1"	(3 1/2 oz.)	\$3.30
OCTURA 30	1 3/8 x 1"	(5 oz.)	\$3.50
OCTURA 45	1 7/8 x 1"	(7 oz.)	\$3.90
OCTURA 60	2 x 1"	(9 oz.)	\$3.95
OCTURA 60-R	2 x 1"	(9 oz.)	\$7.95

for Rossi 60 special collet, spacer, OC-10F included.

For Super Tigre 15 order 5 mm collet,  
S-T 29 and over—7mm collet

**OCTURA  
UNIVERSAL JOINTS**



Hardened Steel-Plated

7/16" hex — 7/16" dia.  
To fit 3/16" drive shaft

\$1.95 per set Specify

10-32, 5mm, 1/4-28, 7mm, 3/16-24

**OCTURA  
SOLID STRUTS**



PARALLEL  
Cast Aluminum  
Includes 2 Nylon  
bushings, 4 screws,  
and 4 "T" nuts.

2"; 1 3/4"; 1 1/2"; 1 1/4" depth

\$2.55 ea.

10° strut also available in 4 sizes at \$2.55 ea.

**OCTURA  
STERN  
RUDDERS**

Cast Aluminum  
Octura Stern Rudder OC-2001  
6 1/4" overall height  
3 1/2" blade below waterline. \$4.85  
Octura Stern Rudder OC-2002  
4 3/4" overall height  
2 1/2" blade below waterline. \$4.50



Under hull Rudders and Water Pick-ups also available.

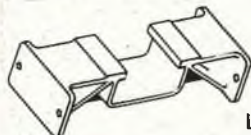

**OCTURA  
MOTOR  
MOUNTS**

Lightweight cast  
aluminum  
4 self-tapping screws  
furn.

Octura 30 (4" wide) \$2.95  
Octura 60 (5" wide) \$3.95  
Octura 90 (7 1/8" wide) \$6.75 screws not furn.

If dealer cannot supply send stamped,  
self-addressed envelope for illustrated  
literature and price list

DEALERS INQUIRIES INVITED

"For Better R/C Model Boating"

**OCTURA MODELS**

8148 Milwaukee Ave. Niles, Illinois 60648

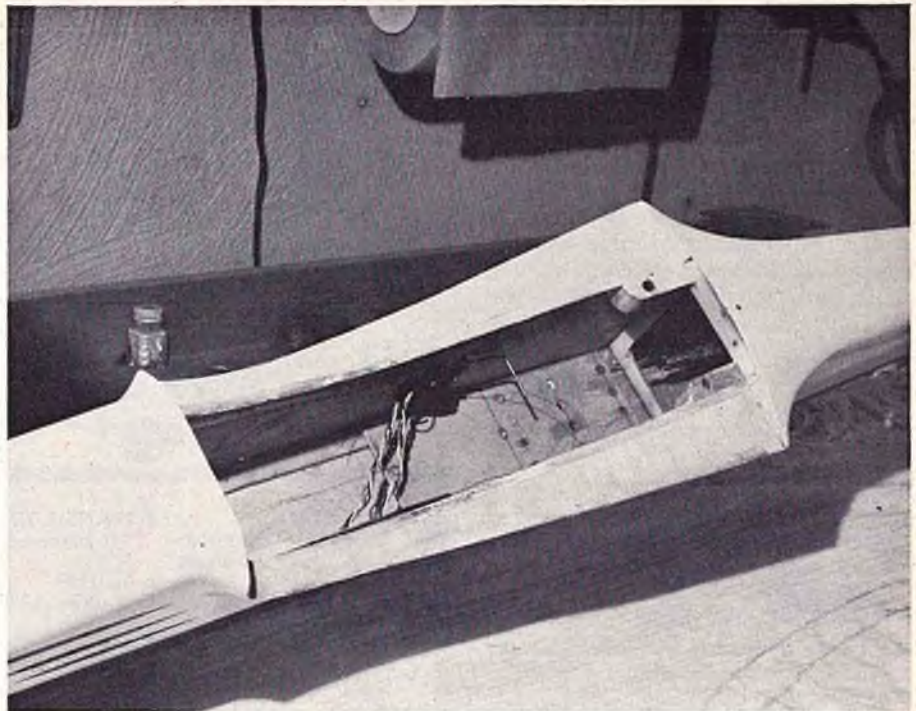

Wing mounting blind nuts are epoxied into the mounting blocks, which in turn, are notched into the rear cabin bulkhead for safety.



Deb-N-Air and co-pilot. The little guy in the cockpit really does the flying . . . Bryan never could get the hang of this new-fangled propo stuff.

place. Lay the assembled side sheets over the plan and mark the position of the formers and vertical bracing.

Mark the position of the motor mounts and cement in place. Cement the formers into one side and when dry assemble the other side over this. Pull the tail cone together, being careful to keep the main fuselage straight. Take a little time here to make sure that the triangular shaped longerons are perfectly flat on top so that when the top block is cemented into position there will be a nice tight fit. Mark the top block and rough cut to shape. Hollow out as much as possible and cement in place on top of the fuse. Fit it carefully; we don't want any big crack along this cemented line.

Next install the blocks around the front of the motor compartment, all bracing inside, and finally cement the bottom cover front and rear in place. Sand the entire fuselage throughly.

Fiberglass cloth reinforcement should be laid in around the motor mounts and firewall. Also at this time a couple of thin coats of fiberglass resin should be painted inside the fuel and battery compartment.

**STABILIZER:**

Construction of the stab is begun by laying out the framework. The next step is to insert the geodetically positioned ribs. Use a 1/16" by 6" sheet to completely cover the stab framework. After drying, the stab can be removed from the plan and the opposite side covered in the same manner. Trim the leading edges and the ends as shown on the plans so as to provide a nice, stream-

**DEB-N-AIR**

(Continued from Page 32)

landings even with the gear turned to the side.

**Construction of the Deb-N-Air  
FUSELAGE:**

Start with a thorough familiarization of the plans. Study them carefully until you feel you have a good understanding of all construction details. Make up a list of the materials required so that once construction is begun, you won't have to stop an evening's work for lack of materials you've overlooked.

First assemble the fuse sides. Be sure the top edge of the 3/32 sheet has been cut with a straight edge so that it is perfectly straight. Cut the diagonal fuselage doublers and cement them in

I HAVE been flying the four channel version of the Digitrio this month and most of the loose ends for the article have been tied up. The four channel modification will probably take two or three months to present, depending on how things go with the art department, space allocation, and available time on my part. I'll finish it as fast as possible, so please don't write in for advance information — we won't be able to release it any faster. The final design uses silicon controlled switches. Warren Thomas and Jim Holman of Jonesboro, Arkansas, are working on a three control stick designed to fit the same case cut-out as employed in your three channel rig. Bernie Murphy is completing the printed circuit board design work just as he did on the original decoder and servo. Recent flights with the four channel have been in a CG Models "Skylark," built by Bob Burand. This airplane has a lot to offer for proportional flying if properly modified. For those of you who might be interested, here are the steps to follow:

- (1) Increase elevator chord to  $1\frac{3}{4}$ ".
- (2) Add ailerons as shown on the plans: (out increase to 1").
- (3) Shorten the wing by removing the two outboard rib sections. Add plywood tip plates.
- (4) Raise the trailing edge of the wing  $\frac{1}{4}$ " to  $\frac{5}{16}$ " by recutting wing saddle on fuselage.
- (5) Install the hottest .23 you can find. Use a 9/4 prop.
- (6) For maximum enjoyment, install steerable nose wheel and brakes.

The Digitrio will fit into this little plane with room to spare. Its light weight is also an asset. In addition to being an excellent flyer, this airplane is also quite durable. A friend of mine, who for some reason prefers to remain anonymous, has landed the Skylark head on into a culvert bank, flew it straight into the ground after a loop on takeoff (he failed to turn on the transmitter switch), and I, myself, have treated it with anything but gentle respect. I finally zigged when I should have zagged and pranged it by driving it straight into the asphalt after a sustained diving maneuver. The motor was a complete wreck but the Skylark recovered with only minor "crunching" of the nose section. This worked out for the good since I had intended to cut off the nose and install a .35. (Editor's note: Sure, Ed . . . sure!) As a result, I'll never again "cuss" the jigsaw puzzle fuselage construction. By the way, the mod's to the Skylark do not imply that the ship will not fly well on proportional without these changes — I can honestly say that I have never seen a Carl Goldberg model that isn't an excellent flyer. I probably never will. These changes were made from my own past experiences and with an honest

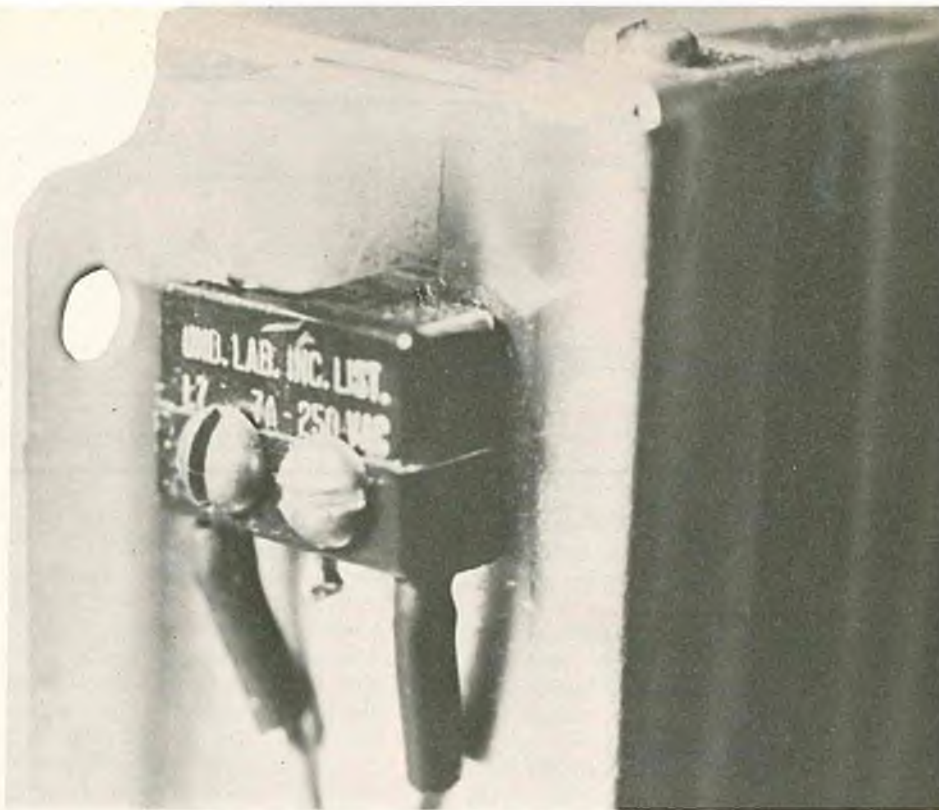

## MODIFYING THE RCM DIGITRIO FOR 3+1 OPERATION

BY ED THOMPSON, TECHNICAL EDITOR

attempt to obtain increased performance.

We are presenting the Three Plus One modifications this month, along with some letters I have received. I have tried my best to answer all of the letters that we have received but find that it is impossible. Unless a letter is a request for urgent information, you will probably not receive a reply. I had saved all of the letters which I felt did not warrant immediate answers, hoping to answer them all eventually, but finally had to re-sort them due to lack of storage space. About 200 of them will have to go unanswered. I had to do this at my own discretion and sincerely hope that none of you will be offended. If you do not receive a reply to your letter and still wish the same information, please write again, indicating that this is the second request.

Next month we'll present the six meter conversion and, hopefully, start the four channel modifications the following month. In the meantime, **here is a revision to the present decoder:** I have checked the motor control one-shot with many types of .1 tantalum capaci-

tors and recommend that R12 be changed from 10K to 22K. This allows a greater margin of successful motor control operation with the various brands of tantalums I tried. If your motor control is sensitive to proper adjustment or sync problems are encountered, this resistor change will probably clear it up.

### DIGITRIO 3+1 MODIFICATION

The 3+1 modification is very simple and will afford an inexpensive means of obtaining coupled aileron operation. The microswitch used for the modification can be applied to any Digitrio servo, such as elevator, to operate electric brakes, etc. The microswitch is a standard production item of Microswitch Division of Honeywell, Freeport, Illinois 61033. Model #1SX1-T is obtainable through any dealer handling Microswitch Division products. If you have a hard time finding this switch, a letter to the manufacturer will get you the name of their closest consumer outlet. The photographs are self-explanatory and should be studied before the modification is attempted. Here is a blow by blow description.

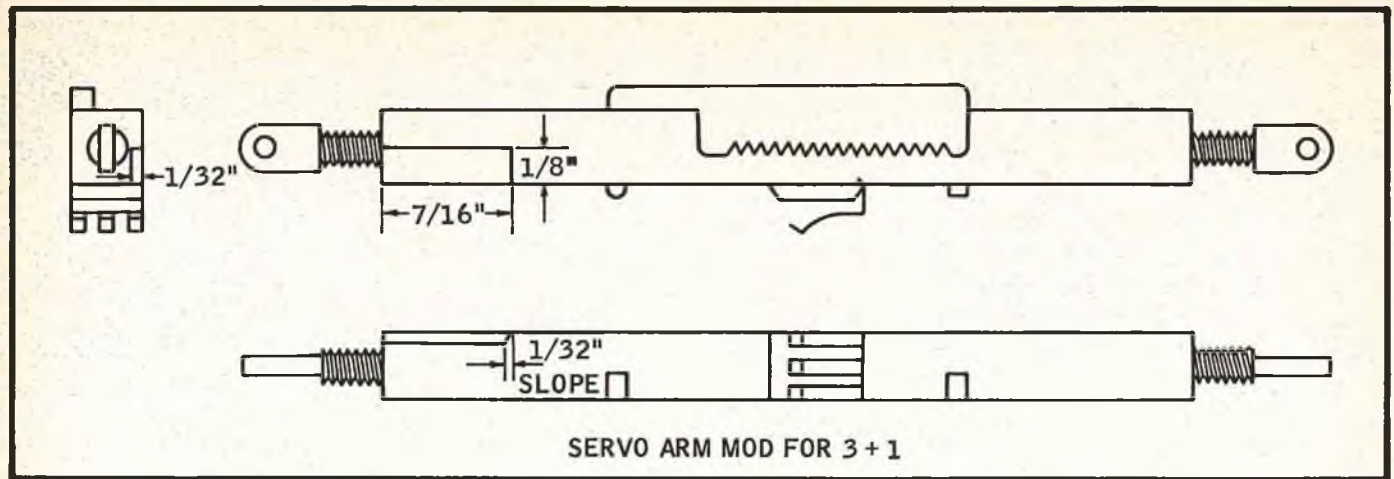

### Installing the Switch

- ( ) Notch the motor servo output arm as shown in the drawing, using an X-Acto knife.
- ( ) Manually place the microswitch into position and operate the servo back and forth to familiarize yourself with the switch action (the microswitch button should rest in the servo arm notch until the servo arm is extended just short of the forward extreme. As the servo arm approaches this extreme movement, the unnotched portion of the arm will depress the switch button actuating the switch).
- ( ) You may have to elongate the holes slightly to provide proper switch positioning — be very careful while doing this and use a fine, small-diameter, round file. If you go too far you'll file into the switch cavity exposing the switch parts which may later "short" against the mounting screws.
- ( ) The right-hand mounting hole of the switch should line up with the servo cover mounting hole. Carefully line up the switch and drill the left-hand mounting hole to accept a #2 sheet metal screw.
- ( ) Mount the switch with two each #2 x 3/8" sheet metal screws.
- ( ) Check your switch installation for positive action and make minor adjustments as necessary for reliable operation.

### Wiring the Switch

- ( ) If you haven't already done so, add the additional channel wires as shown by dotted lines on the decoder overlay and run them through a new grommet.
- ( ) Remove the six-pin motor servo plug and replace it with an eight-pin plug. Wire the first six pins identically with the old plug. Run two new blue wires from the outer switchpin connections to the additional two pins on the new servo plug.
- ( ) Remove the six-pin motor servo connector and replace it with a matching eight-pin connector. Wire the first six pins identically with the old connector. Route the blue wire, shown by dotted lines on the decoder overlay, to one of the additional pins of the connector. Run a blue wire from the remaining pin back through the decoder case and out the extra channel grommet.
- ( ) Plug the aileron servo into the unswitched output and the rudder servo into the switched output.

Here is how it works: With the motor control servo at full advance throttle, the microswitch button is depressed and there is no connection between the fourth channel and the rudder servo input. Thus, the rudder servo will be inoperative. When the motor control servo is retarded slightly, the switch button will rise into the servo arm notch, connecting the rudder servo to the additional channel output and you will

have coupled aileron/rudder operation. NOTE: While flying, make sure that the rudder servo is neutralized before uncoupling, as it will stay in the position you leave it after uncoupling.

### LETTERS

I am very much interested in the do-it-yourself DIGITRIO proportional system for R/C; however, I want to know (1) if the complete plans are now available in package form and (2) if the complete plans are available with those components and instructions necessary to make this system suitable for operation on the 50 MC amateur band. Please, advise me on this matter at your earliest convenience. If these plans for 50 MC operation are now available, please send one (1) set and I will remit payment.

*There are no complete plans available for the Digitrio. RCM is going to publish a complete booklet at the conclusion of the series. 50 MCS operation is possible and the modifications will appear in subsequent issues. Dave Holmes of Grafton, Va., has a Digitrio on 50 MCS at the present time and his modifications are appearing in present issues of RCM.*

I have read with considerable interest the first two articles on the "Digitrio" proportional system. However, before making a decision as to whether or not to build this unit, I would like more detailed information than has yet been given. My main concern, which is also shared by several of my friends, is the

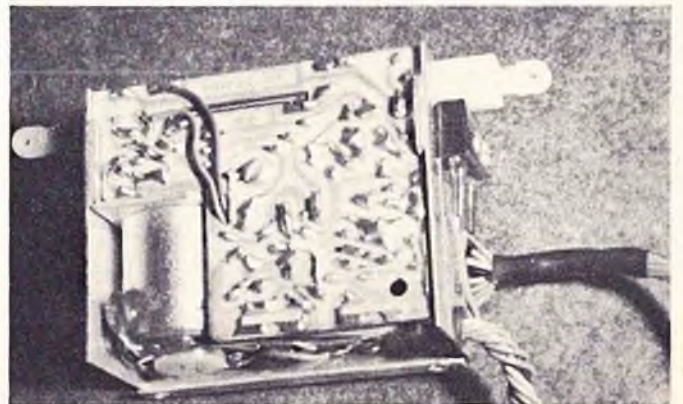
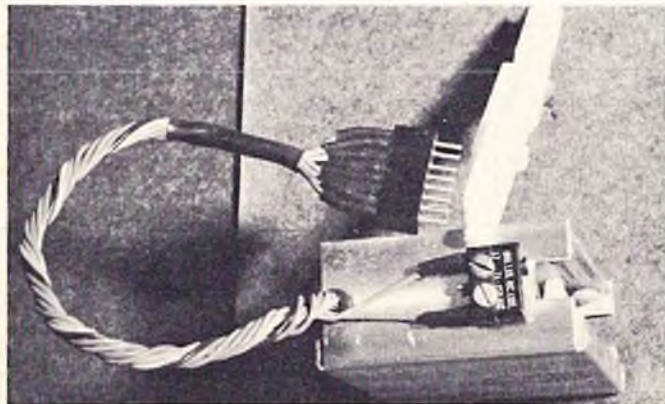



wound L2 coil form shown on page 27 of the September issue shows 12 turns primary and 3 turns secondary using #24 wire. The picture on page 28 could not possibly have a 12 turn primary as I tried winding this form using #26 Teflon coated wire and could just barely get all turns on the form. Is the schematic on page 27 correct or is the picture on page 28 correct? Incidentally this article is the basis of my subscription to RCM, an extremely interesting and useful magazine.

*The Coil form is wound with twelve turns No. 24 enameled wire. The No. 26 teflon-coated wire would have almost twice the diameter of No. 24 enameled wire.*

effect of interference, particularly as no mention of a fail-safe device has been made in the first two articles. I assume that the unit has proved perfectly satisfactory in normal use, but have any specific tests been made to ascertain the effect of nearby transmitters? Another point of interest is the addition of extra channels, and the ease with which these may be added. Perhaps you can tell me if this will be covered in the present series, or whether it will be the subject of a separate article at some future date. I would be grateful if you could possibly give me answers to these points, as the Digitrio seems ideally suited to my needs. If I might be so bold, I would suggest that numerous readers would appreciate a test report on this outfit in the same style as your product reports. In conclusion, I would like to compliment you on an excellent magazine.

*Thank you for your interest in Digitrio. Generally speaking digital systems are more susceptible to noise than reed systems. This can be minimized by proper design and operation. This system has been tested extensively by actual flight and I have not experienced other than normal interference from other transmitters. I have flown both with and without failsafe in the system and find that failsafe is not worth the extra complexity and expense involved especially for home constructors trying to economize. Most crashes of radio controlled aircraft are due to equipment malfunction rather than interference. Failsafe does not protect you in all such cases. You should make proper checks for interference and have a supervised flight line before flying any system. Addition of the fourth channel will be printed separately at a later date. A test report on Digitrio will undoubtedly be presented but probably not in the same form as usual. It would be a bit presumptuous for RCM to report on its own system. The test report will probably be based on reports of actual usage by readers of RCM.*

I am building the RCM Digitrio, but have run into a small snag. The hand



I have started collecting parts to build the Digitrio system. It looks like a good R/C system! I work at Eastman Kodak Co. and can have the printed circuit boards made here if I can get clearance from RCM to reproduce the printed circuit layouts. I have read the articles carefully but have not found any statement relieving a commercial photographer or company such as Eastman Kodak of the copyright restrictions. I am enclosing a self addressed stamped envelope in the hope that you will provide me with a short statement to the effect that it is permissible to copy and reproduce the layouts in this article. Since this technicality is hampering my building of the Digitrio, I would appreciate hearing from you soon.

*Permission is granted for reproduction of printed circuit drawings pertaining to the Digitrio for your own personal use.*

Eight members of the Aero Radio Club of Flint are attempting to build your "Digitrio" proportional system shown on the R/C Modeler magazines. We regretted reading that revisions modifying the unit to a four channel device will not be discussed until **much** later. Originally when we banded together to build these we felt that these revisions would be presented shortly after the last article or that mention of methods would be in each issue covering individual components. In the original magazine issue, it was implied that this system was easily convertible from three to four channels. We feel that adding the additional pulse to the transmitter is quite easy; however we have not built a complete transmitter as yet because of a shortage of components. A number of receivers have been built and operational checks have been excellent. Now for our **problem** — The decoder has us stumped. Enclosed is a block diagram of our system. We added an additional flip-flop triggered by the original flip-flop (every second pulse). Naturally we also added another gate and changed the time constant of the frame rate from 6.5 to 8 milliseconds. A bread board set-up of this arrangement indi-

cates a false spike pulse occurs at each gate when both flip-flops switch. The transistor we used for this bread board set-up were slower than the Fairchild units specified. We do not anticipate substituting for the Fairchild transistors after we prove the circuit. If you have any suggestions to aid us or can describe what you originally had in mind for the decoder when it was stated that it was easily convertible to a four channel device, we sure would appreciate the information. A self-addressed envelope is enclosed for your convenience. I am sure you are very busy but we certainly would appreciate any assistance you can give us.

*Originally I had in mind two flip-flops and a one shot for the decoder. I have now changed to silicon controlled switches and am presently compiling necessary material for the four channel modification.*

My subscription to RCM started with issue No. 1. I do not regret it, believe me. I very much appreciate articles like the Digitrio: for its contents, for its presentation, for the pictures. Mr. Thompson gives very clear explanations and has to be warmly congratulated for it. Now, here, Digitrio is "the talk of the town" among modelers. But we are waiting for the information with which we will be able to build the **four** channel version. In the introduction to the first Digitrio article you promised the publication of conversion informations for 3 to 3+1! Do you remember? We desired to wait until these informations have been published so that we will be able to have the correct P.C. board in the TX and in the decoder. We believe they have to be changed as no spare circuits for the +1 (of 3+1) are to be found on the P.C. boards of the 3. Now we are very much astonished and very much disappointed to read in RCM January 1966 that these informations will be delayed — only because readers did not request these informations. Why should the readers ask for it when the informations were already promised. If you give to your children a 3-wheeled car and promise the fourth wheel for

next Xmas, are your children supposed to ask for the fourth wheel every week until next Xmas or are they supposed to wait until time has elapsed? A great interest for the 3+1 is present, so please do not delay the publication of the long awaited informations.

*Like many other people you have mistaken a statement of fact as a promise. The facts are that the Digitrio can be expanded to four channels. No spare circuits were included on the Digitrio circuit boards since it was a three channel system (hence the name "Digitrio"). Here is another statement of fact — the Digitrio will be expanded to four channels and you can tell your children they will soon have their "fourth wheel." I am very happy that the Digitrio is popular in GENEVA and I hope some day to be able to visit your wonderful country again.*

I have come across a few problems in building my Digitrio and I would like to ask you about it. The problem is getting some of the parts. I would like to quote from the August 1965 issue of *Radio Control Modeler*: "The parts list has been checked, re-checked, and revised to make sure that there is almost universal availability of every component used." I would like to say that the only "universal" place seems to be World Engines Inc. I have nothing against W.E., but I believe that some of the parts are available somewhere else as well as W.E. and maybe even at less cost to the modeler. The parts in question are the Fairchild transistors and the I.F. transformers. The Fairchild transistors are not to be had on the open market (2N3638 & 3640's). I have written to places as far away as Florida and traveled as far as Atlanta, Ga., in search of them but none are to be had. I can't even imagine where you got yours in the first place! I have also written to the Fairchild Company but no answer yet. The I.F.'s you used were similar to the ones sold by Lafayette Radio (I believe) yet the W.E. ones were at twice the price of the ones by Lafayette. I can't help but believe that somewhere there is a plan to all this. I don't believe that W.E. should be the only ones to profit from the building of the Digitrio! Well if you are still with me and not mad yourself I would like to ask a favor. I am sending you some information on the Lafayette I.F. coils, do you believe they will work in the receiver, if not why? Also I would like to ask about the transmitter ant. Is it  $\frac{1}{4}$  or  $\frac{1}{2}$  wavelength? What is its overall extended length? I would like to center load one of my own. And last I would like to know where, besides W.E., can you get 2N3640 & 3638's. Is there a substitute for them or for that 155T1C? In closing I would like to say that I am not as unhappy as I may seem. I have enjoyed very much building the Digi-

trio system and can't wait to get it in the air. I would like to thank both you and RCM for this series of articles.

*You are not alone in your trials and tribulations of parts procurement. I myself aged five years, went through two sets of tires and became a cigar chain smoker trying to procure parts for my prototype! I am quite sure that a lot of the parts are available from a source other than World Engines, Inc. You might also consider that if it wasn't for World Engines' huge investment in money and labor to procure and stock these parts the Digitrio would not be available to the less experienced "scratch" builder. You are right, there*

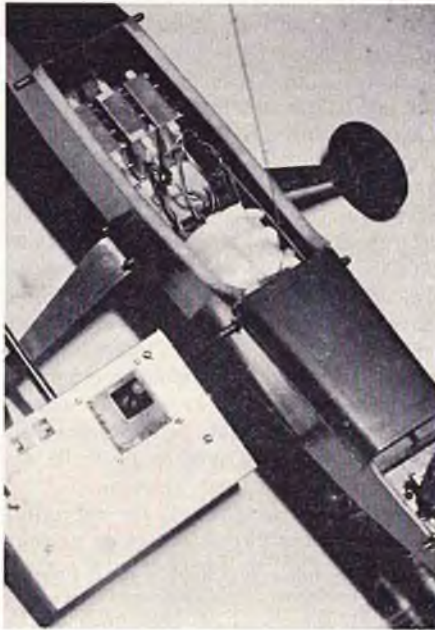

*is a plan to all this. It is simply to allow modelers like yourself to build the Digitrio. If you had written to Fairchild Transistors in the first place you could have saved yourself a lot of trouble trying to find their products. I simply looked in the yellow pages of the telephone directory under Electronic Equipment and Supplies — Manufacturers. Any reputable electronics distributor would have given you Fairchild's address. If you do not know the difference between Lafayette's IF transformers and ones sold by World Engines you shouldn't be trying to substitute them anyhow. They may work well but I have not tried them personally, and if you use them you are on your own. If you think World Engines is the only one profiting from the Digitrio I would suggest that you look up the numerous ads in this copy of RCM selling Digitrio parts, accessories, etc. The antenna is  $\frac{1}{4}$  wave length long. If you want to centerload one of your own I would suggest a 54 inch length and that you check for resonance before using it. I have not tried substituting any of the*

*transistors used so I have no recommendations. I am glad you are not too unhappy and that you have enjoyed building the Digitrio. You are welcome for the articles.*

Mid-January, five members of Cincinnati Aero Modelers started construction on five Digitrios. Four using coupled aileron and rudder and one using the three servos. About one month later Feb. 20th all five systems were complete, distance checked and flown with no malfunction. I might add, most test flights were flown in the 30 degree temp range. The parts kits were World Engine (Digitrio kits). The only substitution was 708 in place of the 706 transistors. Everything went together nicely and alignment of Xmtr. and tuning of RCVR was very simple — following the step by step instructions. Of the five Xmtrs — four worked and one took several hours to locate a cold solder joint. Of the five RCVR/decoder units — four worked, the fifth having an open IF coil, and of the nineteen servos, eighteen worked — the nineteenth having a shorted transistor. Possibly overheated in installation. We feel that this low percentage of error was due to 1) the experience and direct supervision of John Day; 2) checking each component before starting construction; 3) reading, understanding and following the directions. We had many nights of fun building our Digitrios, gained the experience necessary to assure ourselves that they can be built, that they are reliable and that we will be able to repair as needed. Our club members have been flying (store bought) digital proportions this past year and with this experience we have compared our Digitrios and are more than satisfied with their operation and are confident of a fun-filled 1966 flying season.

*Boy you guys really work fast! I don't think I could build one as quick myself, especially now that my workshop is arranged in layers of manuscripts, letters, parts, etc. I am glad you found the equipment satisfactory at low temperatures. Here in Arizona it is pretty hard to come by temperatures in the 30 degree range. My testing was done in the deep freeze which goes down to about 20 degrees. I suspect that the equipment may possibly go even lower but have not had the opportunity to find out. Why don't you pick a nice cold day like maybe 0 degrees and let me know how yours works down there. I am sure the other readers would be interested. I am very pleased to receive letters like this one as they make all the work and long hours expended in a project such as this worthwhile. It won't be long now before you can put John to work again on the four channel modifications.*



**H**AVE you ever steered clear of scale or scale-like airplanes simply because you didn't want to tackle the wing fillet? Have you just overlooked (usually on purpose) the fuselage fairing across the bottom of the wing because you couldn't make one fit?

Take heart — here is a method that is economical, easy, fast, hard-as-nails, and guarantees a perfect fit every time. Interested? Then read on. If you follow this step by step method and **don't ad lib**, you'll surprise yourself with the professional results you can turn out.

**Step 1.** Cut a piece of  $\frac{1}{32}$ " veneer, or  $\frac{1}{32}$ " plywood, large enough to fit the wing opening and extend outside the fuselage far enough to complete the fillet to its extreme limits.

**Step 2.** Bond a piece of closely woven cloth, such as bed sheet, to it using contact cement. Be sure the cloth is bonded over the entire surface and that any lumps of glue under the cloth are smoothed out with a small roller, your fingernail, or any other suitable round-edged tool.

**Step 3.** Place the veneer or ply side against the wing saddle and draw the fuselage outline on the wood. Remove the laminate from the fuselage and draw the fillet outline on the wood, using the fuselage outline for a guide in order to determine the width and shape of the fillet. Cut out with a knife. (See drawing A.)

**Step 4.** Score the wood side along "A" and "B" and bend slightly. Apply HobbyPox Formula 1 glue to the wing saddle and tape along dotted lines A-C and A-D. This will hold the laminate tightly against the wing saddle. Place some plastic wrap over the wing to keep it from being inadvertently glued down and put the wing in place in the saddle. Tape the outer edge of the wing fillet to the surface of the wing so that it will assume the correct contour while the epoxy cures. When it sets, go on to Step 5.

**Step 5.** Cut a piece of styrofoam large enough to make the fillet. Do not use the beaded foam because it is too

# FILLETS

BY CAPT. JOHN D. WOODS, USAF

*Smooth out the appearance and performance of your next R/C ship with easy-to-make fairings and fillets. Here's how . . .*

soft for this application and does not give the proper rigidity to a wing fillet. Cut one edge of this piece straight so the wing saddle outline can be cut on a jigsaw. The top and bottom outline of the wing fillet can be cut at this time, again using the saw. If your wing has a lot of dihedral, you must take this into account when cutting out the saddle. (See Drawing B.) Cut "A" to "B," then "A" to "C." Glue this to the fuselage with white glue before cutting the styrofoam to the plan form of the fillet. Allow to dry thoroughly.

**Step 6.** When the white glue is dry, cut the styrofoam to the plan form outline of the fillet and sand as desired, using the various size dowels to obtain the desired curvature of the fillet.

**Step 7.** Obtain a large desk blotter and cut a pattern from a strip of the blotter that has first been dampened to allow it to follow the exact contour of the fillet. Use this pattern to cut the two fillet covers — one for each side.

**Step 8.** Dampen the covers and glue to the fillet, using white glue, and allowing to dry thoroughly. Do not rub on the damp blotter material to make it conform to the fillet because the paper will roll up and peel off. If you want

to make it adhere or conform better, press it with your fingers, or alternately, roll it with a short piece of dowel of suitable diameter. You will be amazed at how easily the blotter can be worked, and just how well it conforms to the surface contours.

**Step 9.** When the blotter is completely dry, feather the edges with medium sandpaper (#150 works quite well), both at the junction with the fuselage and the edge that meets the wing. Sand **away** from the blotter, not **into** it, since it still tends to roll up. Sand carefully.

**Step 10.** Rub HobbyPox Formula 2 glue into the blotter with your finger or any suitable tool that will allow you to work the glue into the fibers.

That's it! The result will be the best fitting, hardest fillet you can imagine! The final method of finishing is up to you, but the HobbyPox Easy-Does-It method is probably the best. The latter can be adapted to upper and lower wing fillets, fuselage fairings, wing tips, and even those hard to make compound curve fuselage tops and bottoms for that next dream ship of yours.

Try it — you'll even surprise yourself with the results you obtain!

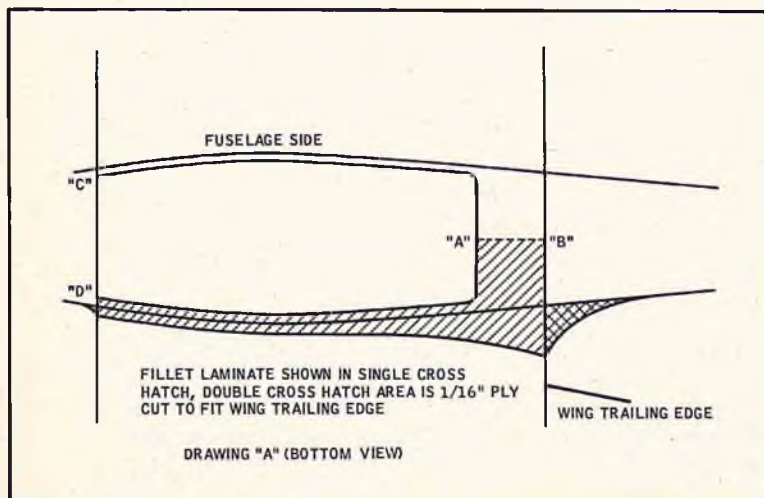

Not as complicated as it may first appear, this method will assure you of perfect fillets and fairings for your next bird.

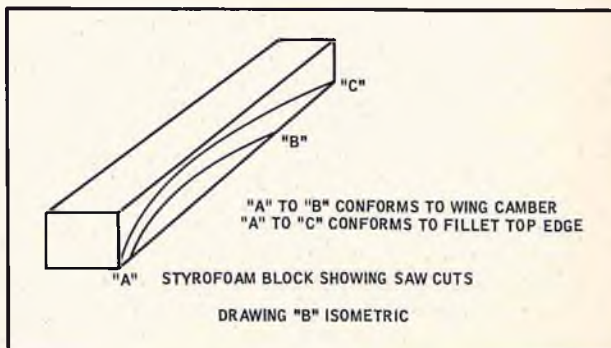

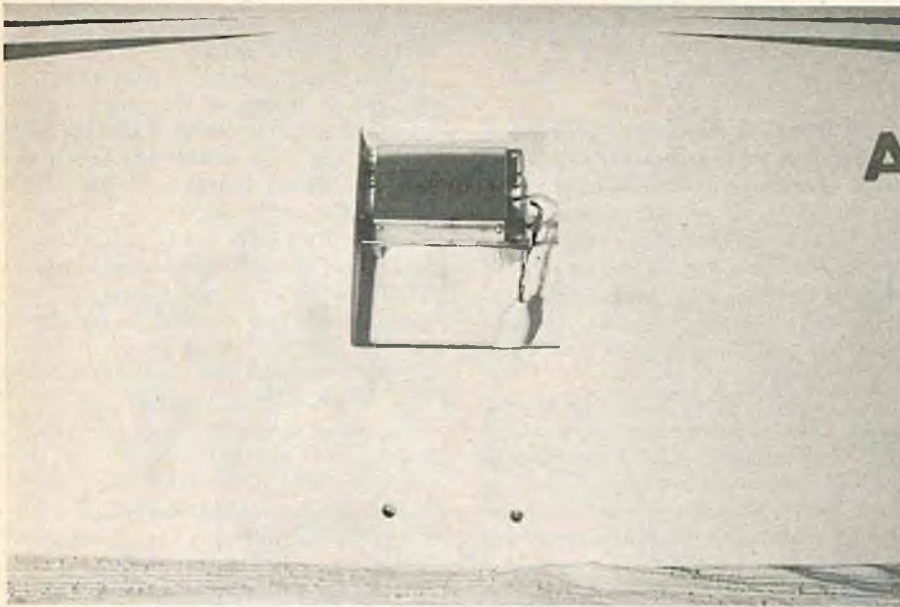

Photo shows the wing screw holes and the dowels at the front. Bryan says Phil Kraft is going to be mad at him because you can't hardly read the word Kraft printed on the Kraft servo, which means PHIL KRAFT won't get the free plug Bryan meant to give him, because the lousy photo didn't turn out so you could read the name KRAFT. Sorry, Phil!

lined, symmetrical leading edge. NOTE: DO NOT SMOOTH OR ROUND ANY PORTION OF THE TRAILING EDGE OF THE STABILIZER OR VERTICAL FIN AT THIS TIME. Do not sand or blend this area until the elevator surface has been finished and is ready for fitting. Keep these rear corners very sharp and square.

#### RUDDER AND FIN:

Assemble the rudder and fin from 1/4" sheet stock. The same rule applies here. Taper and sharpen the leading edge of the vertical fin to a nice, streamlined edge, but keep the rear hinge line area absolutely square and the corners sharp. (These sharp corners are rounded **very, very** slightly with 400 sandpaper just before covering.)

In constructing the control surfaces of the rudder and elevator, they may be cut out and tapered at the **trailing** edge in the usual manner to a nice streamlined edge. The leading edges of the surfaces can be planed to a shallow "V" as noted on the plans. This taper should be just enough so that when full control is applied, the hingeline shuts right up. This is the condition we want as we don't want any loss of air spilling through the crack, nor do we want any turbulence created around the hingeline. Now the surfaces can be sanded to a nice blending contour by laying them in position against their mating stabilizer and sanding. Leave the leading edges of the control surfaces sharp at the corners as shown on the plans. Do not attach hinges. These will be attached after finishing.

Fit the stab to the fuselage keeping the center line parallel to the thrust line (o). This should be relatively simple since the thrust line is the top edge of the fuselage and since the horizontal stab is perfectly flat except for the frontal taper.

Next the vertical fin is fitted and installed. Make sure this is located straight and square by using the pin and line method over the top fuselage block. (Pin is located at front of top block in center and line of thread is stretched around the fin. Make sure line is even on both sides of the fin.) Fillets for the empennage should be cut from sheet stock, sanding very closely to the proper shape before installing. They should be hollowed out, somewhat, on the inside edge and the corners feathered to fit between fuselage and stabilizer. Don't depend too much on fillers or glues for smoothing out these fillets. They should be fitted as tight as possible and sanded to shape almost entirely without the use of any filler. Filler adds weight like crazy so keep it off if at all possible. Very little should be required.

#### WING CONSTRUCTION:

The best way to construct a good straight wing is to use a wing jig, not the expensive store bought kind, but a homemade one. This can be built in one evening for about \$2.00 worth of materials and is really worth the effort. A good wing can be built very simply by using two pieces of 3/4" plywood 1 ft. wide by 3 ft. long, backed up with a 1"

(Continued on Page 84)



## ACE R/C CATALOG

The 1966 Ace R/C Catalog has been completely revised and has been systematized for your convenience. With the organization and comprehensive index, it is no longer necessary to paw through endless pages of material to try to find some elusive item.

In three hole binder punched form, the Ace catalog forms the basis for a continuous and easy filing of additional material, including the regular supplements that come from Ace R/C to all of its regular customers. Still only 10 cents, which is less than the cost of handling and postage.

Also available from Ace is a virgin vinyl binder of the three hole standard type. This can be used to hold your Ace R/C catalogs, the Ace R/C supplements, and additional R/C data that you gather and want to keep in a convenient place.



VIRGIN VINYL BINDER FOR THE ACE R/C CATALOG ONLY NET \$1.90, OR ORDER BOTH THE ACE R/C CATALOG AND THE VIRGIN VINYL BINDER FOR \$2.00.

ACE RADIO CONTROL HIGGINSVILLE, MISSOURI 64037

### FASTEST GROWING HOBBY CENTER

## IN NEW YORK CITY

WE WILL NOT BE UNDERSOLD  
**\$\$\$ \$ SAVE \$\$\$ \$**  
 OUR EXPANSION HAS ALLOWED US TO BRING YOU THE LOWEST PRICES ON ALL LEADING R/C EQUIPMENT, INCLUDING MULTI — ALL IN STOCK, ALL BRAND NEW — OR TELL US YOUR NEED AND RECEIVE OUR LOW QUOTATION —

**\$\$\$ \$ SAVE \$\$\$ \$**

IN THE MARKET FOR MULTI PROPORTIONAL? CHECK OUR PRICES FIRST! **IN STOCK NOW!** DEE BEE CL-5, DIGIMITE, ORBIT, KRAFT, LOGICTROL, F&M, SAMPEY, CONTOLAIRE, MICRO-AVIONICS, MIN-X, AND OTHERS. We will BEAT any Price on Citizenship A.P.S.!

Citizenship 10 Channel — \$125.00  
 SEND 10c STAMP FOR NEW PRICE LIST!  
**OUR 13TH YEAR OF SERVICE**

## BROWN'S HOBBY CENTER

6031 BROADWAY, BRONX 71, N. Y.  
 One Block North of 242nd St., "E1" Station  
 OPPOSITE VAN CORTLANDT MANSION  
 KI 8-5422

ALL BRANDS OF MERCHANDISE IN STOCK

## LOOK WHAT'S NEW!



**SCALE MODEL SKI-BOAT - 35" LONG FOR A 29-.65 GLOW PLUG ENGINE. KIT CONTAINS MOLDED FIBRE-GLASS HULL AND DECK WITH COMPLETE BUILDING AND TRIMMING INSTRUCTIONS . . . . . \$29.95**  
Original "Thunderbolt" design by Glen L. Bellflower, California. Life size plans may be obtained from Glen L.

### the "TAS" =RACING ENGINE=

**2 1/2 HORSEPOWER  
GLOW PLUG ENGINE  
WITH WATER COOLING  
\$39.00**

- HIGH TORQUE
- RECOIL STARTER

- \* Tas Engine Mount \$1.95
- \* Complete Universal \$3.75
- \* Exhaust Stacks Available Soon



TERMS: F.O.B. Broadview, Illinois,  
Prepaid orders only . . . add 10% of the retail  
cost of the order for shipping charges (\$5.00  
maximum in U.S.A.). Dealers inquiries invited.

COMPLETE CATALOG 25¢

**G.E.M. MODELS**  
P.O. BOX 342-BROADVIEW, ILL. 60153

## DISCOVER WHY

Nashville Hobby Center is the  
No. One Hobby Shop in the U.S.A.



Jam packed with all new advertised brands of R/C equipment. We will match any offer. If you are closer to us, you are assured of faster service. Cash or trade-in for used multi sets and ignition motors. Over 100 built-up and ready-to-fly R/C aircraft in stock.

### USED SPECIALS:

10 ch. SH Citizenship TX+Rec.+5 Transmits+Medco pack and charger; all wired plugs and switches ----- \$175.00  
Sampey 404 — Complete and working — \$188.00  
Orbit 6 ch. SH TX+Rec.+3 Transmits, Medco pack & charger, all wired & working \$140.00  
Glass City Mark II Pulsmittor & Capri Rec.: like new ----- \$40.00  
New built-up RCM Digitrio TX, Rec+TX-Pak ----- \$125.00  
Send 10c for Special Bargain Bulletin

**NASHVILLE HOBBY CENTER**  
903 Church St. • Nashville, Tenn.  
Phones 255-9209 — 255-5346

## DEB-N-AIR

(Continued from Page 83)

by 2" frame, squared and glued, and topped with regular bulletin board material. The two sections are joined in the middle with regular door hinges. The pins can be pulled for storage and the hinges allow you to set up various dihedral angles. This wing will assure a straight wing even if your bench is not as flat as it should be (very few are, believe me).

Cut out all ribs and false ribs according to plan. This is best done all at once on a jigsaw. The tapered area ribs are made by progressively cutting down the regular ribs one at a time according to the plan. Actual assembly of the wing is very straight forward and requires no special explanation. The wing is full sheeted with  $\frac{3}{32}$ " soft balsa, and sanded down to about  $\frac{1}{16}$ " using fairly coarse sandpaper cemented to a straight pine block. (Linoleum paste works fine for this. Use garnet sandpaper.) Follow up with fine sandpaper. Take your time and make it real smooth. This is the secret of a nice finish later on. The ailerons are cut out after assembly and re-installed after finishing. Use a razor saw and work carefully.

When the wing is done drill the holes for the mounting screws and the large countersunk area for the screw heads. (I use a metal cap from an old fountain pen, as a hole cutter for balsa. Sharpen the edges and break off the clip.) Balance the wing by adding weight in the tip block to the lighter pane.

Fitting the wing to the fuse comes next. Work and measure very carefully now. We want a perfect fit the first time. After we finish the wing fillets, it's pretty difficult to do much more fitting, so get it right the first time. Install the wing and hold it in place with rubber bands to check fit and alignment. The wing centerline should be marked on the leading edge to use as a measuring reference point. With the fuselage blocked up to where the stab is perfectly level both in roll axis and in pitch axis the wing should be perfectly level as measured from the reference center line to the floor, and as measured from the centerline to the floor at the trailing edge of the wing. Sand the wing saddle area as necessary to accomplish this. Also make sure there is no tilt of the wing in relation to the stab. Any tilt here will produce a turn in the looping maneuvers, and will cause the airplane to stray off course in straight flight. Don't kid yourself about getting perfect fit and alignment. Remember, it's better to spend the whole evening fitting the wing properly, than to fight an impossible airplane

from now on. Use bits of paper to locate tight and hollow spots between the fuselage and wing.

When you are satisfied you have the wing set at exactly 0° decalage, and it is aligned perfectly level with the stab, you are ready to install the wing attachment dowel former and the blind nuts for the nylon screws.

Install the two wing attachment blocks, one on each side of the fuselage at the rear of the wing opening. These should be epoxied in good as we don't want to lose the wing in an outside loop the first flight. Also, cut out former F 2A which will be installed next.

The wing is held in place by dowels at the front and nylon screws at the rear. Obviously, the trick here is to get the dowel locating former (F-2A), and the blind nuts for the attachment screws, properly located.

First place locating former F-2A on the wing dowels. (Use wax paper between former and wing.) Apply glue to the front side of F-2A and carefully install the wing. This will position F-2A against former 2 and will properly locate it vertically. Make sure the wing is positioned exactly where you want it. (The oversized dowel holes in former F-2 will allow F-2A to slip around some for accurate alignment.) The wing should be held firmly in place with rubber bands until dry.

Mark and drill the holes for the attachment screws at the rear by inserting the drill right through the holes in the wing. A brass tube slipped over the drill bit will prevent damage to the wing while drilling. Remove the wing when dry and "safety dowel" former F-2A. Insert the blind nuts in the support blocks at the rear wing opening, and epoxy in place. Re-install the wing using the wing attachment screws to hold it in place this time. This will assure good alignment of the blind nuts until dry. Now we can start on the large wing fillets.

Lay a piece of wax paper on top of the wing to protect it from glue. Carve and fit the solid front fillets from soft sheet. Work carefully and avoid damage to the fuse or wing. Cement the  $\frac{3}{32}$ " sheet fillet foundation in place against the fuselage sides. Note that these are cross grain. Next the large fillets are formed from  $\frac{3}{32}$ " sheet by wetting one side of the sheet and bending it over a cardboard mailing tube. It is a good idea to make a thin cardboard pattern which can be cut and tried until you get the proper fit before cutting the balsa ones. Taper the underside edges of the fillets with a razor blade and sandpaper so you get a good fit against the cross grain foundation pieces and against the fuselage sides. Cement in place. Feather edge to fit when dry.

Cut the fillets for the underside of the

wing from solid **soft** sheet. Carve and sand to fit and glue in place. Sand all wing fillets to a nice contour. These fillets are what give Deb-N-Air her clean lines and complete absence of self-make turbulence.

Give the entire airframe one more last going over using fairly fine sandpaper to effect a nice clean appearance. Take your time and remember, now is the time to make any last minute corrections in alignment, decalage, etc.

#### COVERING AND FINISHING:

Give the whole airframe two coats of clear dope, and sand with 320 sandpaper. Now give it one coat of real thin filler. Hobby-poxy stuff thinned to a **watery** consistency is excellent. Sand this all off leaving filler only in the pores or cracks. If there are any open pores left, give it one more coat of **thinned** filler. Sand all off again leaving filler only in the pores. We must keep weight down. Now give it one more thin coat of clear before covering with Silron. Sand lightly before covering with 400 sandpaper wet. Cover carefully making butt joints wherever necessary to joint.

After covering give the whole airframe 2 thin coats of clear followed by 2 **thin** coats of Hobby-poxy stuff. Sand this filler all off except what remains in the pores of the Silron. Follow it with 2 coats of clear.

Naturally you should sand carefully with 400 wet between these final coats before putting on the color. Take a long last look at the surface now because this is your last chance to make any minor repairs, fill any cracks, etc. Your final finish will be no smoother than it is right now. O.K.?, now we are ready to put on the color. This is the easy part really. The plane should require no more than 2 or 3 coats of dope and the light color should be put on the entire airframe as a base coat. We used white and trimmed in red and blue.

As you put on the color, sand carefully between coats with 400 wet. Be careful not to sand through, especially around the edges and sharp corners. Spraying lays it on more evenly but it is certainly not necessary to achieve a plastic-like finish job. You must sand out the brush marks (if any) between each coat. They aren't going to get any better as you build up subsequent coats over them. Sand carefully before applying masking tape for each trim color.

Take plenty of time between coats, preferably two or three days. After completing the finish job allow two or three weeks for it to cure before final sanding and rubbing out. Install the ailerons, elevators, rudder, landing gear push rods, guide tubes and equipment now while the paint is curing. If metal slip hinges are used and cemented in place with epoxy cement, all controls can be installed without damaging the finish or needing to spot repair around

the hinges. Use DuPont rubbing compound to rub it out, and Johnson's Pledge as a final gleaming wax job.

If you've followed plans to the letter, you now have a beautifully finished, perfectly true airplane that should fly right off the board with no further adjustments, except the minor trim corrections required for contest winning flights.

#### TRIMMING:

Check all controls to assure they are hooked up correctly (I dedicate this remark to my old flying buddy wrong ailerons Corrigan). Make sure they are all free and work easily. This is a must with any contest design. Also make a last check of C/G, (both in pitch and roll). Check to see everything is centered perfectly, crank in a small amount of "up" trim in the elevator and "let 'er go."

There have been countless articles written on "How to trim an R/C airplane," so I'm not going to elaborate at length on the subject. However, I will cover a couple of the more important principles involved. Adjust the control links until you have perfect straight and level flight. Don't even attempt to stunt the ship until she'll fly hands off in straight flight and will do smooth, gentle turns by maintaining just a little elevator trim or back pressure. You may have to alter engine side thrust or down thrust a little and maybe change the aileron neutral setting a little if you have a slight imperfection in the wing or empennage somewhere. But don't compromise this final trimming job. Take your time and get it right. Half the fight is won in a contest if your airplane tracks perfectly through all the maneuvers.

You'll find the Deb-N-Air is every ounce a winner both in style and performance. Not too many R/C enthusiasts realize that good clean lines and smooth "debonair" flying go hand-in-hand.

You will when you build and fly your own Deb-N-Air.

### EDITOR'S MEMO

(Continued from Page 6)

'American Modeler' publication. This, then, in my opinion, puts the Executive Director in a position of protecting the interests of a private enterprise rather than the general membership which pays his salary. It would also appear to put the Executive Council in a position of simply "rubber stamping" the wishes of the Executive Director without regard for the wishes of the AMA members of their respective districts. And if

(Continued on Page 86)



## Radio Control HEADQUARTERS

AMERICA'S HOBBY CENTER 146 West 22nd St., N. Y., N. Y. 10011

<b>RADIO CONTROL EQUIPMENT</b>		<b>Reg. Sale</b>
CITIZENSHIP TWO TRANSMITTER & 20-10 RECEIVER.....	199.90	129.95
CITIZENSHIP NEW SUPER NET RECEIVER.....	34.95	25.95
CITIZENSHIP SPE TRANSDORIZED TRANSMITTER.....	39.95	28.95
CITIZENSHIP TLR of TCR TRANSDORIZED SERVO (EACH).....	25.95	19.90
ELECTRONICS TWO LITE ALL TRANSDORIZED TRANSMITTER.....	29.95	24.95
ELECTRONICS SINGLEMATIC COMPOUND ESCAPEMENT.....	14.95	9.95
CITIZENSHIP 8 CHANNEL SUPERNET RELAYLESS OUTFIT WITH 510-RLS-71B SERVO, TCR SERVOES.....	207.95	129.95
NAAFIT RELAY RECEIVER TUBE TYPE.....	29.95	12.95
SUN MINATURE COMPOUND ESCAPEMENT.....	7.95	2.95



### Pee Wee

READY TO OPERATE R/C OUTFIT

FULLY TRANSDORIZED

RECEIVER'S VOLT RELAYLESS OPER. 40-1/2" 40-5/16" 1/4" X 1/4" TRANSDORIZED INDEPENDENT FINGERLE MEASURES: 1 1/4" 3/16" 3/16" COLLAPSIBLE INT. WIRE SWITCH.

24 88

BOTH TRANSMITTER & RECEIVER

<b>RADIO CONTROL ACCESSORIES</b>		<b>Reg. Sale</b>
FAST LINE Regular 200 Each...SET OF FOUR FOR	95	59
INLINE TRIM BAR.....	95	59
BEANS & PIN PLUS & JACK SET (FLAT TYPE).....	60	39
24 FEET FLEXIBLE HOSE-UP WIRE (6 COLORS).....	60	39
<b>RADIO CONTROL ENGINES</b>		<b>Reg. Sale</b>
ENYA .09 R/C.....	9.95	6.95
ENYA .15 R/C.....	14.95	10.95
ENYA .25 R/C.....	24.95	18.95
ENYA .35 R/C.....	36.95	28.95
<b>RADIO CONTROL AIRPLANES</b>		<b>Reg. Sale</b>
DARBY LIVERMORE PURSUIT For .29-.45 ENG. 65" WINGSPAN.....	19.95	14.95
DARBY LIVERMORE CUSTOM For .35-.50 ENG. 65" WINGSPAN.....	21.95	15.95
ELECTRONICS LIBERTY 7 For .049-.090 ENG. 45" WINGSPAN.....	7.95	5.95
BERKELEY R/C BUSTER For .15-.35 ENG. 48" WINGSPAN.....	19.95	9.95

Send for our NEW R/C Catalog listing everything available in R/C!

CONTROLINE 5 RECEIVER KIT \$7.95, ASSEMBLED \$13.95, FAN PIONEER RECEIVER \$18.95, FAN ECHO TRANSMITTER \$29.95, MC NICAD CHARGER \$5.95, ASTRO TONE MONITOR \$14.95, ASTRO PEE WEE RECEIVER AND TRANSMITTER \$24.95, ASTRO 22 RECEIVER AND TRANSMITTER \$29.95, REP. UN-CHARGER \$10.95, CRYSTAL: 13, 32, 26, 95, 27, 045, 27, 095, 27, 145, 27, 195, AND 27, 255 EACH \$2.89 CRYSTAL HOLDERS 25¢, FUSIBLE BY WIDGEST \$5¢, FAN RUBBER 6" x 6" 25¢, 6" x 12" 50¢, MINATURE SWITCH SPST \$1.49, HI CAP BATTERY PACK 6V-500 MAH \$10.95, MFLON ACCESSORY 60¢, TATONE INSTRUMENTS: 1/4", 3/16", 3/8", 7/16", & 1/2" EACH \$1.75, GREENE R/C TERMINAL BLOCK \$2.75, WILLIAMS METERS: 0-3 \$3.95, 0-5 \$2.95, 0-50 \$2.29, PENCIL BATT. BOX 25¢.

**RED HOT BUY !! CITIZENSHIP ANALOG**

CITIZENSHIP ANALOG SYSTEM \$250.00 WITH A FREE BONUS DIFF. CERTIFICATE FOR 381.00 MERCHANDISE OF YOUR OWN CHOICE.....

**WE ALSO SELL TO DEALERS**

HBO-AD AGENCY DISTRIBUTES EVERY REPUTABLE R/C ITEM. WE HAVE THE WORLD'S LARGEST INVENTORY OF R/C EQUIPMENT. WRITE FOR OUR SERVICE PROGRAM.

**WE WILL PAY YOU TO SEND FOR THIS WORLD'S NEWEST & MOST COMPLETE R/C CATALOG**

SEND ONLY 25¢

For Our New R/C Catalog R.C. FANS V. & Get a 50% CREDIT HERE IS OUR BRAND NEW CATALOG, PICTURES & DESCRIBES ALL FAMOUS BRAND EQUIPMENT & ACCESSORIES..... Refundable With Your Next Order

Order By Mail From **AMERICA'S HOBBY CENTER, DEPT. RCM**  
146 WEST 22ND STREET, N. Y., N. Y. 10011

## ARISTO'S NEW MOTOR CONTROL ESCAPEMENTS



**2-SPEED \$5.00**

**3-SPEED \$5.00**

Compact: 1 5/8" long X 1 1/4" wide X 2 1/4" high.

Lightweight: Only 3/4 oz. . . . Aristo's New 2 and 3 Speed Escapements are ideal for hook-up with Aristo's CODE-A-MATIC and RUDDERVATOR Servos. Spring-Wound (60-70), both escapements are easy to install in the smallest Radio Control model planes. If you already own Aristo's Code-a-matic and Ruddervator Servos, these control escapements are a "must" for R/C flying perfection.

SEND CHECK or M.O.—NO COD'S PLEASE

Dealer Inquiries Invited We Export Everywhere

POLKS HOBBIES

Dept. RC 46  
314 FIFTH AVE., NEW YORK 10001

## HELP WANTED!

L.A. distributor seeks R/C'er as purchasing agent/assistant manager. Diversified duties, including technical advice to customers, manufacturer liaison. Thriving firm, excellent potential. Rush your sales pitch, qualifications and salary requirement to Box 487, R/C MODELER, Sierra Madre, California.

## GRAHAM Radio Supply

PAMPLICO, S. C. 29583

Send Postcard For  
Free Catalog and  
Manufacturer's Literature

Tell Us Your Needs!

SAMPEY • F&M • LOGICROL  
WORLD ENGINES • MIN-X •  
ORBIT • BONNER • BABCOCK  
NEW BONNER DIGIMITE-4  
AND OTHERS

## CLEVELAND

### Miniature Masterplans

Brand New! Thirty Vintage Cleveland Miniature Masterplans.  $\frac{3}{8}$ " scale. (Upgraded SF's reduced) for Collectors, Students, Modelers. 30c, 45c, 60c each. All 30. \$12.00 (Save \$2.55). SF  $\frac{3}{4}$ " Scale Plans Pre-publication Summer Specials! Stearman PT-17, Sperry Messenger, DH-5, Thunderbird, Robin, Post Sport, Verville Sport, Thomas-Morse S4-C, Fokker E-III, Tiger-Moth, Sopwith: Pup, Camel, Baby, Tripe. Each Complete \$2.00. 25-30 Outline plans of rare prototypes. Set (24) \$3.95. Many more. Catalog Subscription 25c.

## CLEVELAND MODELS

4506 Lorain, Cleveland 2, Ohio

## NORTHERN CALIF. R/C MODELERS

## \$ SAVE MONEY \$

### ON YOUR NEW UP-TO-DATE R/C EQUIPMENT

Trade in your old R/C gear or engine, get the newest, the latest R/C system

### Buy the Correct Choice the First Time

Send 25c for Latest List of New  
and Used R/C Equipment

Since 1946

## ROOT'S HOBBY HUT

6036 TELEGRAPH AVE. OAKLAND, CALIF.  
NOON TO 5 P.M. EVENINGS 7-9

BUY IT WHERE  
YOU CAN SEE IT OPERATE

## EDITOR'S MEMO

(Continued from Page 85)

they disclaim this fact, I would like to see the general membership ballot that authorized this transaction. Failing this, at least produce the Leader Member ballot that shows a majority vote from this group. As a Leader Member, I certainly don't recall voting on this proposition. Without such a vote, on what basis did the Executive Council **assume** that their "unanimous" vote represented the wishes of the rank and file membership?

Additional facts of interest include the fact that, not only did the general membership not get a chance to vote on their preference in the matter, thus denying the democratic process to the membership, but the general model aviation magazines were **not even asked** if they would care to participate in this same program. This fact was confirmed by this writer in telephone conversations with Walt Schroder of Model Airplane News and Don McGovern of Flying Models. Thus **one** publication was chosen over the others—why?

The Academy claims they want maximum exposure for the Academy, yet of the three general publications, Model Airplane News has registered the highest **paid** circulation.

Perhaps it was based on past allegiance and participation in AMA programs. Yet, both Model Airplane News and Flying Models have contributed thousands of dollars in free advertising space to the Academy, have financially supported, as sponsors, the Nationals each year, and the editors of both magazines have been Academy members for many, many years, with one of them being a Fellow in the Academy.

Perhaps it was based on editorial content of the three publications. Yet, both Model Airplane News and Flying Models have proved, over the years, that they are devoted to all phases of model aviation, while American Modeler has leaned quite heavily toward other aspects of modeling, such as slot cars and the like. Sure makes you stop and wonder about the motivation behind this maneuver, doesn't it?

All in all, the general membership was denied the democratic process of free choice by general ballot; the Executive Director admitted that the entire "deal" was supposed to be kept confidential until completed; and one newly purchased publication was selected without even offering the same opportunity to the other publications. This is going to raise a great deal of speculation, and the furor among the AMA general membership, Leader Members,

publications, and members of the industry is already overwhelming.

And speculation and guesswork can lead to close scrutiny by those interested enough in the preservation of democratic principles to investigate a situation. As an example, there was a case not so long ago, where a major industry, in dire financial straits for some time, was sold to another corporation who shortly thereafter began to show a rapid growth in the profit column of their financial statement. When the speculation and guessing finally did lead to a closer scrutiny it was discovered that this profit was due to an exclusive government contract for a particular item of manufacture. It seemed that the owner of the corporation had a close friend in government circles, and the commitment of influence to swing a government contract to that firm was instrumental in that individual's decision to purchase that corporation, despite its financial condition.

This, of course, couldn't happen in our own circles. But, as I mentioned, speculation and guesswork when all of the facts are not known, and when the given answers are incongruous with the facts of the matter, might lead a few people to wondering about the whys and wherefores of the matter.

Why all the editorial furor from a specialized publication such as R/C Modeler which is **not directly** involved? Simply this: Radio control is but one phase of model aviation, and there are approximately 100,000 active and semi-active RC'ers in this country. The total membership of the Academy of Model Aeronautics is approximately 18,000. And although we were specifically asked by the AMA Executive Director **not** to release this fact, **over half of the total Academy membership are RC'ers**. Thus, the radio control segment of model aviation is supporting **more** than just its own segment of model flying, and thus should voice a very strong opinion in matters where an attempt is made to stifle that voice or, alternately, make the decisions for the membership.

We believe completely in the necessity for the Academy of Model Aeronautics as the governing body of model aviation. We also believe in the rights of the membership to be able to voice their own opinions in the democratic process. And this isn't the first time in the past few months that such an event has taken place within the Academy—it's just the first item that's been brought to light, and of the severest magnitude.

You may get a free magazine with your AMA membership, but the price you're paying for it goes well beyond your membership dues.

The real price is membership **without** representation—without the democratic process of free choice.

In each issue of 'Model Aviation'

magazine there appeared the phrase — "The Independent Voice of American Aeromodeling."

That phrase, and the principle for which it stood, was also part of the price.

In virtually every piece of Academy literature was the phrase describing the AMA as the governing body "of, by, and for model aviation."

That phrase, and the principle for which it stood, was also a part of the price.

That price, Mr. Worth, is too high.

## KEN WILLARD . . .

Regretfully, I have to report one item that evolved at the show, and one which you all know about by now. I say regretfully, because regardless of the pro's and con's, and irrespective of the outcome, the method whereby the Academy of Model Aeronautics negotiated, and then announced, their affiliation with American Modeler magazine, leaves many questions unanswered. As you all know, I have consistently promoted and encouraged membership in the AMA, and I sincerely hope that as the facts become known, the real reasons behind this association of a non-profit organization with a commercial magazine can withstand close scrutiny. But the unilateral and somewhat dictatorial method by which the arrangement was concluded leaves us AMA'ers pretty much in the dark — and I'm afraid I find the explanation in George Wells' press release rather shallow and glib at this writing.

Maybe it will all work out. I hope so. But I'm not going to devote any more space to it, unless something really deserving of attention comes up. You and I have got too much Sunday flying to do. We'll let the legal and political experts unravel the AMA's problems. I'll continue to be a member, even if I get classed as the "loyal opposition," as the British put it.

## BERNIE MURPHY . . .

Last Summer, in an attempt to attend a contest in Florida, AMA's Executive Director, John Worth, inadvertently boarded the wrong plane.

Again, recently, Mr. Worth took off in what I feel to be the wrong direction. This time he took the AMA's Executive Board along for the ride! This time there was no plane involved — just a trip down the garden path.

What has happened? The AMA has joined forces with a commercial model magazine. The AMA's Model Aviation will no longer be printed. Instead, the AMA news will be carried as a part of a commercial enterprise. All members will receive this magazine as part of

(Continued on Page 88)

**AT LAST** in the **SOUTHEAST** area. What ever your needs are. Kits — Motors — Servos — Accessories and R/C equipment.

Open every evening till 11 P.M. Mail orders shipped same day received. Phone in the evening, mailed the next morning. Just over the bridge from Augusta, Ga.

### Miller's Hobbies

315 Laurie Drive Beech Island, S. C.  
(Phone (803) 822-0565)

## Moving? New Address?

Please notify our circulation department of your change of address by the 5th of the month so that your next issue of Radio Control Modeler will arrive at your new address.

Radio Control Modeler Magazine  
Circulation Dept. • P.O. Box 1128  
Laguna Beach, Calif.

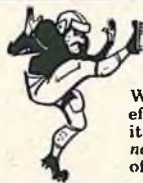

## ZIP!

(Code, that is)

When new Postal Regulations go into effect, your mail will be delayed if it doesn't show your Zip Code. Start now to give your Zip Code as part of your address on ALL your mail.

HELP YOUR POSTOFFICE HELP YOU

## P.C. BOARDS

FROM YOUR ARTWORK. SEE MARCH, APRIL & MAY RCM. ALSO DIGITRIO

## WEST COAST SLIDES

P.O. BOX 788 SAN PEDRO, CALIF.

## NOW!

Pre-Cut Parts For All Plans From Radio Control Modeler and Nelson Model Products.

By special arrangement with RCM and Gerald Nelson, Plans Parts Service provides all wood parts precut and sanded, ready to build from the above plans.

### NOW AVAILABLE:

Nelson's Bonzo, Loving Special & Shoestring, each ----- \$9.95  
RCM's Royal Coachman ----- 4.49  
Digester ----- 7.98  
BD-1 ----- 11.95

All Others Available Soon At Comparable Prices

Write for information and prices.

Send Check or M. O. with orders to:

**PLANS PARTS SERVICE**  
215 W. 4th St., Oxnard, Calif.

## For the Utmost in Advanced . . . ENGINEERING, QUALITY, AND RELIABILITY ... DEPEND ON KRAFT



All Kraft transmitters are exceptionally powerful, drift free, and operate from inexpensive, long-life, dry batteries. The 6, 10, and 12 channel transmitters are dual simultaneous. All Kraft receivers use the same basic superheterodyne circuit whether single channel or proportional. The reed receivers are the smallest and lightest available.

### Kraft Matched Sets — Transmitter with Superhet Receiver

1 Channel	6 Channel	10 Channel	12 Channel
\$64.95	\$119.95	\$189.95	\$209.95

Kraft Proportional System  
(now in production)  
complete system with all  
accessories, ready to install

\$489.95

Kraft Heavy Duty  
600 Mah Reed Battery Pack

\$19.95

With matching charger

\$23.90

*Kraft Systems, Inc.*

2519 Lee Avenue • South El Monte, Calif.

All Kraft Custom Radio Control products are available through your local Kraft Franchised Dealer. If unavailable, you may order direct from the factory. Be sure to include check or money order for items ordered. If you prefer, you may send a 50% deposit, balance C.O.D. Calif. residents add 4% sales tax.

**DIRECTORY OF**

**APPROVED MODEL DEALERS**

Dealer Directory spaces are sold on a year's basis at \$70 per year (payable in advance) or at \$5.85 per month (minimum one year); also for six months at \$40 (payable in advance only). Ads will be set in standard listing typography. All insertions must be consecutive and may be charged if you have credit established with us. No mention of mail order business permitted. **CLOSING DATE:** 8th of the second preceding month.

**TELL YOUR DEALER YOU SAW HIS AD IN THE RCM DIRECTORY**

**ARIZONA—TUCSON**

Ace-Kraft Franchised Dealer  
Sig Balsa  
All Supplies Stocked  
**DON'S HOBBY & CRAFTS SHOP**  
5329 So. 12th Ave.

**CALIFORNIA—OAKLAND**

Trade Up to New R/C Equipment  
SAVE \$ \$ \$  
Send 25c for used equip. list  
NOON TO 5 EVENING 7-9  
**ROOT'S HOBBY HUT**  
6036 Telegraph Ave.

**CALIFORNIA—SANTA MONICA**

**RADIO CONTROL**  
Sailplanes Boats Planes  
Imported & Domestic Hobby Supplies  
**WILSHIRE MODEL CENTER**  
1326 Wilshire Blvd.

**MASSACHUSETTS—ATTLEBORO**

Ace-Kraft Franchised Dealer  
Twelve years in Radio Control  
Open evenings and all day Saturday  
**HOBBY HUT**

170 Pine Street 222-0957

**MASSACHUSETTS—CAMBRIDGE**

Ace-Kraft franchised dealer  
Babcock representative dealer and  
other leading brands  
**CROSBY'S HOBBY CENTRE**  
1704A Massachusetts Ave.  
Phone KI 7-4889

**MASSACHUSETTS—LAWRENCE**

Merrimack Valley's Most Complete  
Hobby Shop  
Open Daily Til 9 — Saturday Til 6  
**MODELER'S HAVEN**

80 Manchester Street 683-3222

**NEW JERSEY—WAYNE**

Specializing Model Aircraft  
& R/C Equipment  
**CARL'S HIGHWAY HOBBIES**  
689 Route 23

**OHIO—KIRTLAND**

**KIRTLAND HARDWARE & HOBBY SHOP**  
Route 306 — 1 mile South of U. S. 90

**OHIO—MAPLE HEIGHTS**

**HOBBY HOUSE INC.—Southeast**  
"Everything for the Hobbyist"  
We Sell and Service All R/C Equipment  
Single - Multi - Proportional in stock  
5240 Warrensville Rd. Zip 44137

**OREGON—HILLSBORO**

**RADIO CONTROL**  
**HILLSBORO HOBBY SHOP**  
351 East Main Street

**OREGON—PORTLAND**

Ace-Kraft Franchised Dealer — See the entire Kraft  
Custom R/C Line first in our showcases.  
The Complete R/Cers Shop Sig Products —  
Aero Gloss — Hobbyoxy — DuBro — TopFlite  
SuperTigre — Merco — Voco — K&B — O.S. Max  
If you appreciate Service — give us a try!  
**HOBBYLAND**  
Phone (503) 287-4090  
4503 N. Interstate, Portland, Ore. 97217

**TEXAS—DALLAS**

Radio Control Headquarters for the Southwest  
Professional Flying Instruction At No Extra Cost  
**BERNIE'S HOBBY HOUSE**  
209-A W. Jefferson

**WISCONSIN—MILWAUKEE**

**OKLAHOMA HOBBY SHOP**  
1103 W. Oklahoma Ave. 53215

**WEST VIRGINIA—HUNTINGTON**

Open Noon "Til Eight  
If you want it, we have it — in stock!  
**THE MODEL SHOP**  
1931 R. Washington Avenue

**ENGLAND—LONDON**

For all European RC Items Including  
Merco Power Units  
Write for List  
**HENRY J. NICHOLLS & SON LTD.**  
308 Holloway Road London N. 7

**ENGLAND—NEWCASTLE-U-LYME**  
(on M.8)

Kraft franchised dealer — Micro-Avionics  
Min-X — F & M — Ueda Engines  
**MODEL RADIO CO.**  
(Jack Fisher) Opp. "Crystal Ballroom"  
Newcastle-under-Lyme, Staffs, U. K.

**EDITOR'S MEMO**

(Continued from Page 87)

their membership dues. You say this is fine — you'll get a regular magazine instead of Model Aviation — why complain? This move puts the AMA directly, or indirectly in the magazine publishing business, in competition with the general model magazines. Is this right? I say no! Emphatically. Not from a competition standpoint, nor from the AMA selling magazines for the AMA. After all, no one objected to Model Aviation. We are opposed, however, to any selective connection with any one commercially published magazine — this one or any other! I feel that this move will do irreparable damage to the Academy.

What has been the key factor in keeping the AMA alive? Support. Your support, our support, and the support of all the magazines. Free advertising space, editorials, and event coverage, have all been a part of holding the AMA together. Now, how can any magazine support, in any way, its own competitor. It's simple — they can't.

I have considered John Worth a personal friend — not only of mine, but of every AMA member. He has worked tirelessly to help the Academy. It is difficult for me to believe that he was a party to this recent contract between the Academy and the newly purchased American Modeler. I choose to believe that his enthusiasm and eagerness to help the Academy have caused a serious error in his judgment. But we all make mistakes.

As a Leader Member and Contest Director of the AMA, and an eager supporter of the "Dump The Deficit" fund, I must urge you to write to your District Vice President concerning this matter. The AMA needs its members — it needs the support of the model publications. And we need the AMA. Don't let the AMA go commercial!

**CHUCK CUNNINGHAM . . .**

The reaction of most modelers and AMA members upon first hearing of the AMA-American Modeler deal was probably one of small joy. At least, it would appear, here was something for their AMA membership — something tangible, that is. This was, no doubt, the reason that the idea was first germinated. The biggest drawback to joining the AMA in the past was the fact that the sport and Sunday fier got nothing tangible for his money. And this was quietly expressed by the fact that, at present, less than 10% of all RC'ers are AMA members. Here, it would seem, was something for his money.

But . . . the man who took a moment to look deeper into the situation realized a much different, and far-ranging prob-

lem. Now, the AMA has removed itself from the ranks of a pure service organization. It has now aligned itself with a commercial enterprise, strictly in competition with all of the other publications as well as a number of modelers. This entry into the world of business was done with money collected for the betterment of modelers **as a group, and as a whole.** Further, this entry was done without the advice and sanction of the general membership, and in fact, with a deliberate attempt to conceal it from the rank and file member.

This has been, and will remain, the greatest hobby in the world. We are rapidly moving into the sports world. When we do, something will be gained, but many of the finer aspects as we have known them will be lost. As a hobby it should provide us with a form of relaxation, a method of forgetting the newspaper headlines of today, or the pressure of everyday business and economics.

It cannot be relaxing if the governing body of that hobby becomes a dictatorship.

The movement of the AMA into the commercial field has all of the ring and maneuvers of some of the less pleasing aspects of big government. And hints of a private "deal" in the interests of a very few at the sacrifice of many.

This step will not economically hurt RCM or any of the other magazines in the field, but it will surely hurt **you**, the modeler. This operation is doomed to failure since the very nature of the R/C modeler is one of independence. He will **not** be dictated to, nor will he stand still and have his money poured down the rat hole of someone else's ill-conceived folly!

This is not meant as a denouncement of the Academy — far from it. It is meant as a denouncement of the current AMA leadership — the men who were instrumental in this action.

If you have any doubt in your mind, seek out your local AMA Leader Member and get his view on the subject. He wasn't even consulted in the matter and had no knowledge that such a transaction was taking place! You will find that, almost to a man, they are opposed to this AMA action.

**ED THOMPSON . . .**

In closing, a brief note on the recent Academy of Model Aeronautics fiasco. I am **not** an AMA member. I belong to the 90% of RC'ers who do **not** belong, and will continue to do so until such time as the bureaucracy that passes itself off as AMA leadership gives the right to AMA decision back to its members. This latest maneuver is just another reason that loads the scale on the other side of the AMA's "Ten Reasons For Joining The AMA."