

RCM SPECIAL: MINIATURE AIR RACING

CDC

radio control

MARCH 1965 50¢

Modeler

AMERICA'S LEADING PUBLICATION FOR THE WORLD'S FASTEST GROWING HOBBY

For the beginner:
Ken Willard's SCHOOLGIRL

Build The
Denight Special
for the
NEW GOODYEAR EVENT

ALLAN K SCIDMORE
5013 DORSETT DR
MADISON WIS.

Λίγα λόγια για μένα.

Είμαι Μηχανικός Ηλεκτρονικός και αυτό είναι το αληθινό μου επάγγελμα εργασίας.

Από μικρός δυο πράγματα μου κέντρισαν το ενδιαφέρον και ασχολήθηκα με αυτά.

Πρώτον ο ηλεκτρισμός και δεύτερον το απέραντο γαλάζιο του ουρανού και ο αέρας αυτού.

Το χόμπι του αερομοντελισμού το πρωτογνώρισα τον Οκτώβριο του 1973.

Μου αρέσουν οι ξύλινες κατασκευές αεροπλάνων και σκαφών από το μηδέν.

Ξεκίνησα να συλλέγω σχέδια, άρθρα, βιβλία και ότι άλλο μπορούσε να με βοηθήσει στο χόμπι από τα πολύ παλιά χρόνια.

Έχω δημιουργήσει μια πολύ μεγάλη προσωπική συλλογή από αυτά.

Από το 2004 άρχισα να ασχολούμαι με την ψηφιοποίηση τους, τον καθαρισμό τους αλλά και να τα μοιράζομαι μαζί σας αφού τα δημοσιοποιώ στο διαδίκτυο (όσα από αυτά επιτρέπεται λόγω των πνευματικών δικαιωμάτων τους).

Σήμερα μετά από όλη αυτήν την εμπειρία που έχω αποκτήσει, αποφάσισα να ψηφιοποιήσω, να καθαρίσω και να ξαναδημοσιεύσω σε ψηφιακή έκδοση και ελεύθερα όλα τα τεύχη του περιοδικού RC Modeler από το 1963 μέχρι το 2005.

Σίγουρα είναι μια πολύ μεγάλη, δύσκολη και επίπονη εργασία αλλά πιστεύω με την βοήθεια όλων σας να την τελειώσω σε ένα καλό αλλά μεγάλο χρονικό διάστημα.

Ζητώ συγγνώμη εκ των προτέρων γιατί τα Αγγλικά μου είναι φτωχά.

Δεν είναι η μητρική μου γλώσσα γιατί είμαι Έλληνας.

Εύχομαι σε όλους εσάς που θα επιλέξετε να τα συλλέξετε και να τα διαβάσετε αυτήν την εργασία μου καλή απόλαυση και καλές κατασκευές.

Το όνομα μου είναι Ηλίας Ευθυμιόπουλος.(Η.Ε)

Το ψευδώνυμο μου Hisat.

Η χώρα μου η Ελλάδα και η πολη μου η Ξάνθη.

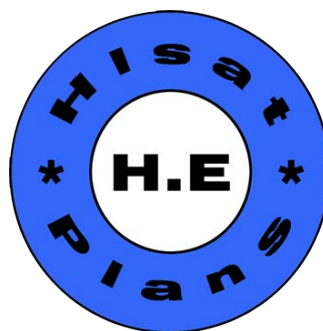

A few words about me.

I am Electronic Engineer and this is my true work job.

From small two things attracted my interest and I dealt with them.

First electricity and secondly the blue sky and the air him.

The model aircraft hobby met him in October 1973.

I love the wooden structures from scratch airplanes and boats.

I started collecting plans, articles, books and anything else that could help the hobby of many years ago.

I have created a very large personal collection of them.

Since 2004 I became involved with the digitization, clean them and to share with you since the public on the internet (as many of them are allowed reason of copyright).

Now after all this experience I have decided to digitize, to clean and to re publish in digital edition and free of all issues RC Modeler magazine from 1963 to 2005.

Certainly it is a very long, difficult and tedious task but I believe with the help of all of you to finish in a good but long time.

I apologize in advance because my English is poor.

It is not my mother language because I am Greek.

I wish all of you who choose to collect and read this my work good enjoyment and good construction.

My name is Elijah Efthimiopoulos. (H.E)

My nickname Hlsat.

My country is Greece, and the my city is Xanthi.

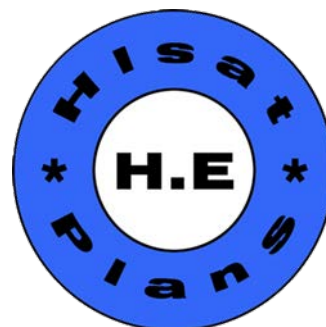

RCM Magazine Editing and Resampling.

Work Done:

- 1) Advertisements removed.
- 2) Plans building plane removed and hyperlinked.
- 3) Articles building plane removed and hyperlinked.
- 4) Pages reordered.
- 5) Topics list added.

Now you can read these great issues and find the plans and building articles on multiple sites on the internet.

All Plans can be found here:

Hlsat Blog RCModeler Free Plans and Articles.

<http://www.rcgroups.com/forums/showthread.php?t=2354459>

AeroFred Gallery Free Plans.

<http://aerofred.com/index.php>

Hip Pocket Aeronautics Gallery Free Plans.

http://www.hippoketaeronautics.com/hpa_plans/index.php

James Hatton Blog Free Plans and Articles.

<http://pulling-gz.blogspot.gr/?view=flipcard>

Vintage & Old-Timer RCM Free Plans.

<http://www.rcgroups.com/forums/showthread.php?t=2233857>

Contributors:

Scanning by ser001

Editing by Hlsat.

Thanks Elijah from Greece.



14 Altitude: 30 Feet Speed: 200 Plus

Air racing... and the Goodyear Event

18 The N.M.P.R.A. and the Year's Hottest Event

Miniature Goodyear racing for R/C

22 The Denight Special Joe Martin

Build this scale version of a famous Goodyear contender... designed under N.M.P.R.A. rules for 1965.

27 Engine Obedience Course Duke Fox

How to tame that wild R/C mill

29 The Schoolgirl Ken Willard

A brand new design from the small plane master... a single channel biplane for .020 to .049. Full size templates.

35 The Proportional Controversy: Two Points of View Doug Spreng

Analog or digital? A former Nat's champion and Caltech engineer delves into the pros and cons of each.

39 To Fail Safe Or Not Al Doig

A rebuttal... and why one flier would rather fight than switch!

40 R/C Design Made Easy Chuck Cunningham

Part I of a series on R/C Aerodynamics

COVER: Into the early morning sun, a line-up of .40 sized Goodyear racers for the new event. Photo by Chuck Waas.

Digital Edition

Hlsat

Editor

DON DEWEY

Managing Editor

CHUCK WAAS

Technical Editor

DON MATHES

Art Editor

DICK KIDD

Contributing Editors

KEN WILLARD

FRANK JUSTIN

JERRY KLEINBURG

GARY PREUSSE

Foreign Editor

CLIFF RAUSIN

Photography

GIL DUARTE

DICK TICHENOR

Consumer Research

BILL O'BRIEN

Plan Service

GORDON MADISON

I.M.P.B.A.

MERT MISCHNICK

Administration

PAT McCLOSKEY

Editorial Assistant

SALLY DEWEY

Reader Service

SHIRLEY BYERS

Correspondents

GEOFF FRANKLIN

BILL MURRAY

MONTE MALHERBE

JACK ALBRECHT

PER-AXEL ELIASSON

CLAUDE BERNARD

JOHN J. CARROLL

WINDY KREULEN

MONTHLY FEATURES

Editor's Memo	6	Regatta	42
Letters	7	Roostertail	44
Top Out	8	Fly-In	13
Solo	11	Washington Report	45

R/C MODELER is published monthly by the R/C Modeler Corporation, 49 S. Baldwin Ave., Sierra Madre, Calif. Contents Copyright 1965. All rights reserved. Printed in the U.S.A. Second Class Postage paid at Milwaukee, Wis. and at additional P.O. SUBSCRIPTION RATES: Annual (12 issues), U.S. and possessions: \$5.50; 2 years, \$10.00. Canada: 1 year, \$6.00. All other countries: 1 year, \$6.50. Payment from all countries must be in U.S. funds. Changes of address must be sent to R/C Modeler as well as to the local Postmaster to insure forwarding. Send old address with the new. Canadian circulation P.O. Box 3005, Vancouver, B.C.

EDITORS MEMO

By DON DEWEY



USUALLY, YOURS TRULY has nothing to say and proceeds to say it in ten thousand words or less. This month we'll have to condense it to about half of that. There were so many "goodies" to include in one issue we ran out of space. We hope you'll overlook the deletion of some of the regular features, such as Fly-In, Showcase '65, etc. . . they'll be back in their respective slots next month. For now, we have a special report on the miniature Goodyear Pylon race event, which by the way, is catching on like a brush fire. Plus Joe Martin's hot Denight Special, designed for this event. Chuck, and Don Mathes flew North to photograph these Goodyear jobs and they're still making noise like a Bonzo around the far turn . . .

Next month, for the newer, and would be proportional flier, Part I of an article on proportional by Cliff Weirick. This is one of the finest 'do-it-yourself' pieces we have seen and will be of help to even the more experienced sport flier. To the newcomer, or loner, it will be like having the Nat's Champ by your side while you solo.

If you spend half your time cussin' your engine, pay close heed to Duke Fox's Engine Obedience Course. The old pro has some choice words about making that mill do what you want it to do, instead of having your vice versa . . .

We've also got some good electronic construction projects of a practical nature coming up for you in the next few issues, plus some more product reports on the new radio gear. This month, the technical staff was recuperating from the deluge of letters that followed the last product report. They were equally divided — half of them wanted our head, the other half were already playing football with it. You may not agree with our findings or our opinions, and we're certainly not infallible. But the

product reports will continue. We'll try to minimize the opinions, and where they do occur, you'll know they are our opinions. Our job is not to sell merchandise for our advertisers — it is simply to provide a magazine that you want to read that merits your confidence, and in turn, provides the advertiser with a good medium with a maximum amount of readers in which he can purchase space and sell his own merchandise. Some readers disagreed with our choice of semantics — such as the word "digital", claiming there is no such thing as a 'digital' system. They are fifty percent right. The so-called 'digital' systems use techniques that are, in all respects, digital techniques, and are, in fact, analog-to-digital conversions. Rather than stop and explain this in every paragraph, and to distinguish one from the other, we use the accepted model terminology, analog and digital. Doug Spreng,

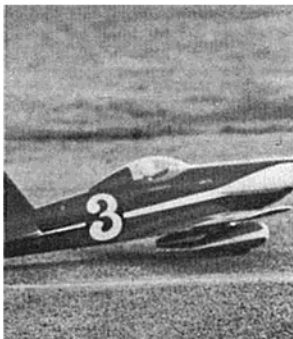

former Nationals champion, and a pioneer designer in the proportional field was asked to write an article describing the two systems — it is included in this issue. Several excellent letters were received taking issue with certain aspects of the proportional articles. We'll present some of the more controversial correspondence, along with a corresponding discussion by our technical editor in the next issue. Don Mathes, who heads up this department, has been working in electronics for many years and designed the early Digicon system. Later, he was associated with Kraft Custom Radio. Today, Don is the Technical Editor of RCM and serves as a free-lance consultant in the proportional field.

The Bowery Boys are at it again. A letter was received at RCM from

(Continued on Page 7)

the Flying Aces of New York (Howard Dart and sons), challenging the Bowery Boys to a combat match. We passed this letter on and they, in a typical fashion, fired off a telegram geared to arrive in New York at 1:30 a.m., accepting the match and suggesting the Southwestern Regionals at Phoenix as a possible site. The following letter was then received at RCM from the Bowery Boys:

Dear Editor:

If there's one thing we don't do, it's read your lousy magazine. But since someone was stupid enough to challenge us to a combat match via your so-called publication, it warranted a letter. First of all, it's hard enough to find anyone on the West Coast that knows how to fly without even considering the East — they're lucky if they can even get them up and down in one piece. On top of that, it's quite apparent the snow has frozen their minds or they wouldn't have challenged us in the first place. Since we have had no acceptance of our agreement to meet this chicken outfit, we will warn any group that we will fly against any of them in unlimited combat. That is, no restriction on plane or engine size. If they insist on streamers, then they will be 12 inches long and attached directly to the airplane itself. None of this mickey mouse thirty feet of nylon string and then a sixty foot streamer. The last ship still airborne is the team winner. And, in case any of these sissified airplane drivers are still interested, have them send a letter.

—The Bowery Boys

Not that these guys are egotistical, or anything like that! We still do not know who they are, but we have watched them fly. It's an experience friend! They wear black motorcycle jackets and black hoods — you can't tell who they are. But the *can* fly! They use all black Midwest deltas with Super Tigre 56's and Fox 59's launched from a VTO rack — and that's no joke! Proportional gear, and those machines are flying at 85 m.p.h. plus as they come straight across the field! And if you're flying against them, they aim for the plane, not the streamer! They don't have too many takers! Their club meeting, held in total secrecy, is rumored to be something analogous to the Appalachian conference . . .

LETTERS

Sir:

Keep up the good work. Your mag is going great. I admire your stand on the equipment reviews. Enclosed are a few words on fail safe (in proportional). A couple of statements in RCM demand a rebuttal. You may burn it, or print it — but there will be a ten minute quiz on the subject in the morning.

Al Doig

Woodland Hills, Calif.

Al's article on fail-safe is in this issue — and well worth reading. And if anyone should wonder about the author's qualifications to write it, we might mention that Al had the first working proportional rig on the West Coast — many years ago. Since that time he has been working with proportional control systems and acting as a consultant in the proportional field.

Sir:

On page 42 of the January RCM mention is made of 'Metal Seal' by General Electric for use in making a fuselage-wing seal. I've tried all the local hardware and auto supply stores and nobody has even heard of it. Can you help?

After looking over the plans for the Digester, I've decided on two things — I'm sure this ship is a fine flier (anything as ugly as that is bound to fly), and two, that if I can't find models to build which at least bear a vague resemblance to a full size airplane, I'm going to take up knitting. I am concerned by the trends in RC, which seem to parallel those of free flight. Up until the time of the Zipper, models looked somewhat like airplanes. Have you seen any lately? Wow! Scale is hard to fly and functional models look like hell. Isn't there any happy medium, Also, who needs a model which will VTO and cruise at 75 mph

I was most impressed by the comments of Mr. Tom Stence in the "Sunday Flier" — a tremendous sense of humor, but more important, many things that badly needed saying. You have the best model mag on the market — keep up the good work.

La Roy H. Mikelson
Speedway, Indiana

Thanks for the many kind comments — if you can't locate Metal Seal, try Clear Seal by General Electric — this is a clear silicon rubber compound which is available in a tube at most hardware stores, et. We agree on the models — take a look at the Goodyear bit in this issue.

Sir:

I am enclosing \$5.50 for a one year subscription to RCM — your December issue was worth this price alone. I purchased a Babcock BC-22 and built the DQA 704 model for my sons Christmas (and mine). The first flight was a hair raiser — the plastic control wires from the actuator to the receiver became lodged under the actuator arm in such a way that we had no left rudder! We had taken the model into an 80 acre field behind the house and parked our car nearby. You guessed it! The DQA 704 dive bombed the car from

four different directions, missing it by the smallest of margins! The engine quite at the most embarrassing time — going straight up! The 704 forgave it by flipping over and making a perfect three-point landing. After fixing the trouble, we put in three more perfect flights and are quite thrilled. This is my 15 year old sons first RC job — my second. I had an old Aero-Trol about 15 years ago. Our DQA 704 weighed in at 12½ ounces without paint, so we didn't paint it. This new equipment is great — doesn't take so much time to build a small plane to lug it around. Don't forget us beginners...

Jack Jackson

Winterset, Iowa

We hoped that the DQA would be well received by the newcomers and sport fliers — we've built five of the .020 versions and one that was enlarged 20% for an .049. All were excellent beginner's ships — extremely stable. Most DQA's will exhibit scalloping tendencies under power. Add downthrust a washer at a time until this is corrected. Don't change the wing incidence, only the downthrust, if the glide is okay. By the way, the C.G. was omitted from the plans — balance the D.Q.A. at the leading edge of the spar.

Sir:

I would like to tell you that you have, without a doubt, the finest and most interesting publication which I have read since I became interested in modeling. I have been modeling for over fifteen years and have held an AMA license for over twelve years. I am currently serving as VP of the LIDS which boasts a present membership of 86. We are using Mitchell Fields as a flying area, owned by Nassau County. I might add that acquiring this facility took long hours and great pains by some of our club members. Our County has been cooperating in every way to help our club and the hobby.

Getting back to your magazine, which was the reason of my writing, I find one fault which troubles many of the club members and myself. The fault is the date on which we subscribers receive the magazine in the mail. It seems we have to wait at least two weeks after the magazine is on the stands to receive our subscriptions in the mail. Can this situation be adjusted?

Larry Davidson

Farmington, N.Y.

We're aware of this problem, Larry, and we are working to correct it. We do not work with the long 'lead time' that the other magazines use — that is why we can always get important news out first, and at least a month ahead of our competitors. By the same token, we cannot mail our subscribers copies ahead of the others — they all go out at the same time, subscribers by mail, and the newstands by truck to the dealers. It is unfortunate, but second class mail, under which all magazines are mailed, can be detained by the Post Office anywhere along the way for priority first class material. This often means that the trucked copies arrive first. But, we're trying.

Editors Memo

(Continued from Page 6)

See you around the pylons. And don't forget to keep those letters coming — pro or con. Mild and sedate, or wild and controversial, there's one thing for sure.

You'll always find it in RCM first.

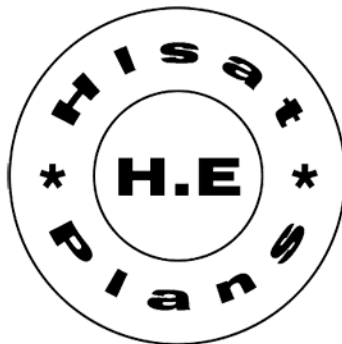
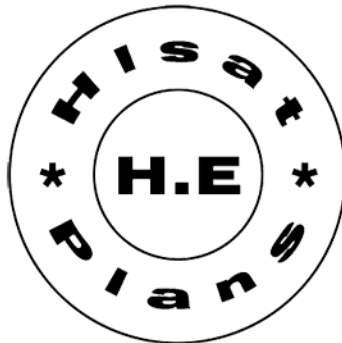

TOP OUT

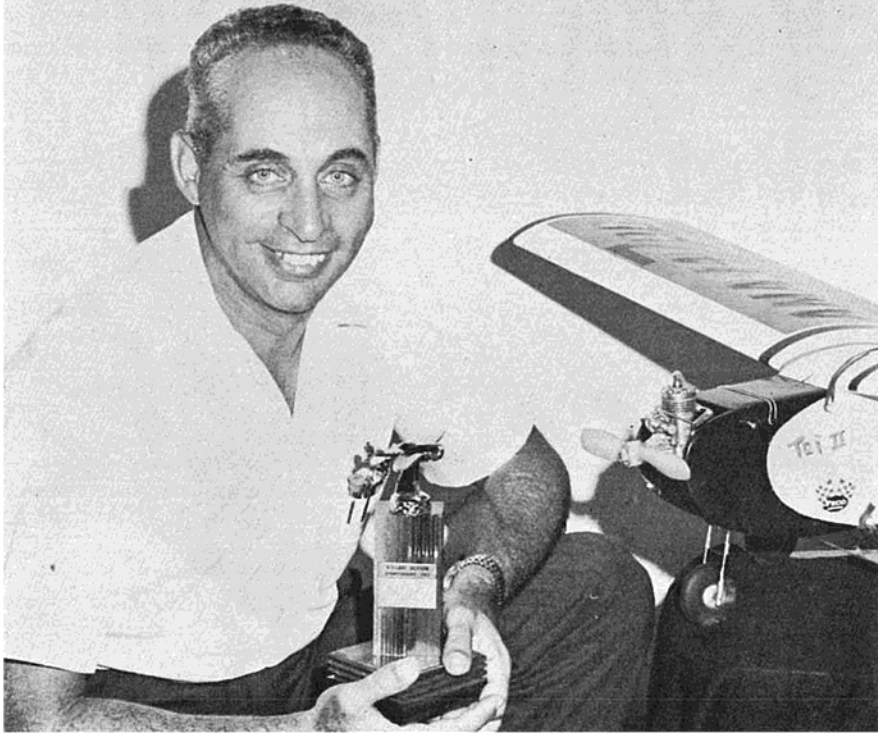

by
jerry kleinburg

It's the season of restlessness.

Each year at this time winter-built energies and planes combine to bring on the RC fidgets which can only vanish with a good flying session.

"Who would make a castor oil skin treatment a way of life," my friend the wood stove philosopher asks, "except mebbe them people who fly them toy airplanes that make so much noise."

"That kind of talk won't help any," I glower — altho I know he's putting me on — "only outdoor action will fill the bill. There's been enough of the contemplative-like palaver, and dreaming up new gadgets, and planning on how to fly, and so on. Now it's time to practice up and trim out this new ship and gear I got with my Xmas bonus," I run on, knowing all the time the old man will have the last word anyway. He does—

"Well, I'd say the weatherman has a lot to say about that. Besides, what's yer hurry? Seems like yesterday you was draggin' around from too much button pushin'. Right now you could dig into some of the notes on those contests you didn't tell folks about,

and — how 'bout that mail, it's quite a pile, Son."

You know, the old man's right...

CONTEST SPOTLIGHT

A letter from Bob Lane of the Lake Jackson RC'ers brings a picture of Jerry Joiner who took first place in the escapement event of Lake Jackson's 6th annual contest. Jerry, the junior member of the Joiner team, is a big help to his dad, Pat, who along with Howard Lincoln and Jack Strickland spark much of the RC action in the Houston area. The Lake Jackson meet, which is backed by the local Optimists Club, has become a well established part of the contest season in Texas. Besides providing enjoyable RC outings and competition, the Lake Jackson group strive to put that "something extra" into their annual effort. This year they added an escapement event which Joe Pasztor, this year's contest director, hopes will grow into a major part of the yearly AAA meet and will in turn offer RC newcomers a competitive opportunity. The progressiveness of the Lake Jackson modelers is seen not only in fly-

ing matters but also in their public relations work. Besides the financial support given by many local merchants, each year radio station KBRZ broadcasts over four hours of live coverage during the meet. Listeners in the area look forward to the annual program which describes the flying action as it ensues. Excitement and suspense of close competition is heightened by first hand comments and impressions of contestants as they are interviewed before and after their flights. Transistorized AM receivers have become part of the contestant's gear for this contest since the broadcast is used to follow scores and action. Spectators also find the program helpful in understanding what's going on. Good use is also made of the valuable air time to carry the story of organized model competition and general activities. AMA affiliation advantages and programs are covered along with national and international modeling news. Jim Hargrove, KBRZ's general manager plus Roy Howard and Chuck Farkas who handle production from the contest site, are working up new ideas in conjunction with club members for their 1965 program.

Another growing Texas organization, the Port Arthur RC Club, had its first contest (22 Nov.) during the first norther to hit east Texas. This didn't daunt or dent Norman Rhodes and that live gang who kept things warm with spirited flying and rumor. Esti Petri claims it got below freezing but this didn't stop husband Pete and his Air Conditioned from taking another 1st in class I. Major C. P. Hart of Fort Sam Houston, a newcomer to competitive RC'ings, took 2nd with another Air Conditioned. The Port Arthur group have their own flying field just west of the city and it includes a dandy concrete take-off area constructed by local members. (Emily, my cuisine chief, has her own reasons for liking the flying site — it's surrounded by wild black raspberries which grow in gratifying abundance and make jam-up jam!) It may be the weather or the oil refinery atmosphere, but the Port Arthur RC'ers put their own stimulating brand on their flying, and together with the big serving of hospitality that they offer, assure success to their future shindigs.

In answer to the contest need for escapement and pulse fliers, various

(Continued on Page 9)

Top Out

(Continued from Page 8)



Jerry Joiner of Houston, winner of the escapement event at the 6th Annual Lake Jackson RC meet, shows the ship that did it for him. More and more clubs are including single channel events.

meets across the country, such as the Lake Jackson Annual reported above, are providing an outlet and incentive for those who follow this approach to RC. Another such meet, designed to encourage and sustain escapement and pulse flying was a late season affair held in Victoria on 15 November. The Victoria RC'ers are fortunate in having two former Army Air Force bases in their area, Foster and Alouh fields with their acres of concrete. Excellent flying facilities were provided at the latter site this year and all RC pattern classes in addition to the single channelers were on hand to take advantage of the broad concrete ramp. Despite 35 mile winds, spectators were treated to a steady procession of special events flights, often three at a time, since superhets dominated the equipment picture. Sponsors of the meet were Ann and Brad Shepard who worked hard to make sure all fliers enjoyed this fly-fest. Leon Folsie took top honors in single channel rudder, while Ben Harr led the way in multi-channel rudder, which was hotly contested in spite of the wind. Gary Horn of Randolph AFB carried off the high point prize, while his flying buddy, Clyde Young, received worst crack-up consolations. Ann Shepard is the proprietor of the House of Hobbies in Victoria and she distributed merchandize prizes con-

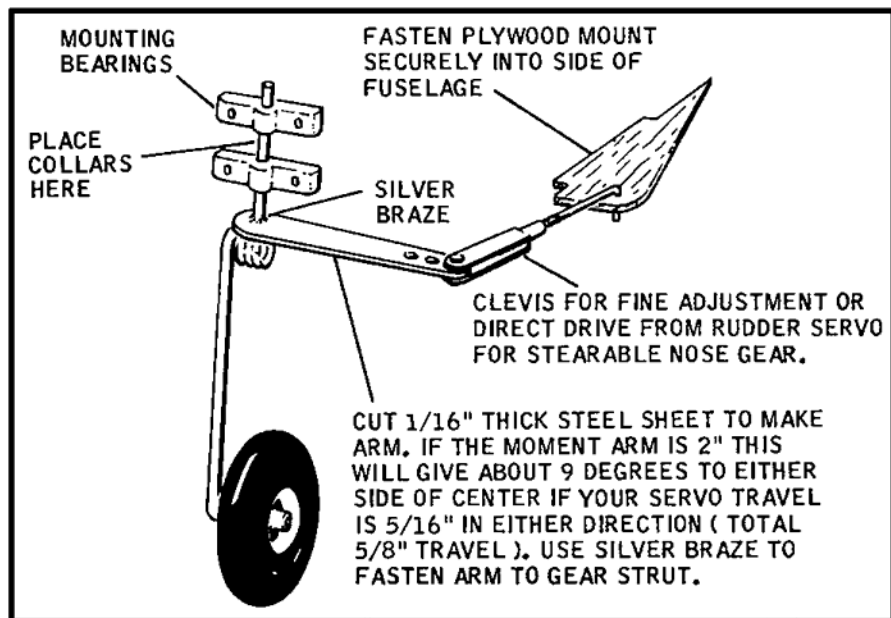

Gary Wedye of Alhambra, Calif. submitted this aid for straighter trike-geared tracking for Class I ships with fixed nose gear.

tributed by some of RC-dom's best names in the selling end of the business — Sig, Ace, Royal, Goldberg, and Testor. For me, the visit to Victoria was a special treat, since it was there at Foster Field I received advanced flying training and graduated in April 1943 — a long time ago!

While touching on the commercial aspects of modeling it is appropriate to consider the help given by manufacturers, distributors, and dealers to encourage and to support competition and the hobby/sport generally. At times we're apt to lose sight of these efforts which often exceed what is considered normal business investment. John Clements who was honored with an AMA Fellow award last September, is an outstanding example of a hobby dealer who has contributed time, talent, and energy for many years in helping to forward modeling activities. John's outgoing manner and gift of making friends makes him especially valuable in his public relations post of the AMA. While it's not possible to name all hobby industry types who provide more than their share where it's needed, a couple who come to mind and deserve recognition are R. L. Hallgren of Hobby Dealers and Ollie Pfeil of Texas Hobby Distributors. Ollie, who is remembered for his pre-WW II model building and flying, expanded into the business side of modeling after military service and now fosters a lot of RC interest above and below the Mexican border from his San Antonio location. R. L.

Hallgren helps to sponsor RC contests in the Dallas-Ft. Worth area which is recognized as the center of gravity with respect to modeling activities in the Southwest. His help and influence tend to keep it that way.

MAIL CALL

A gratifying part of doing this column is the mail received from across the country with its encouraging and interesting comment and views. Let's take a look at a few:

A letter from John Worth, AMA's Executive Director, wishing TOP OUT good luck brings word about possible multiple year memberships, aimed at further reducing operating costs as well as to hold down dues costs, too. Two, three, and maybe five year memberships may be offered, which in addition to other factors, would help stabilize AMA financial management — a considerable task. It would also make possible long range money applications which is the most effective way to stretch cash and to manage projects not otherwise possible.

Paul Runge of Ace RC and the AMA-Radio Control Committee sends a short letter touching on the voluntary fund which supports our legal representation to obtain better radio frequency space from the ECC. Last season proved the essentiality of having enough radio spectrum to allow several flight lines to operate at the

(Continued from Page 10)

same time. Prior to 1964, meet planners were concerned with the possibility of having to limit registration at the Nats and other major RC contests. Multiple flight lines using 27mc Citizen Band frequencies and superhet receivers provided some growing room and alleviated the problem somewhat. However, future growth points up the need for more channels of interference-free facilities, and this is the objective of Paul's committee. The committee's work, a long-range undertaking, is our best bet to assure achieving a substantial technical foundation capable of supporting a greatly expanded RC activity. Sudden thought: It would be a real step forward for class I to have separate frequencies and its own flight line at the Nationals.

Can't pass up the 'hasty note' received from Carl Goldberg who needs no introduction here. Carl's comment about present RC'ing reminding him of the dynamic activity of the late 30's, recalls high school days at Lane Tech in Chicago and the pre-Zipper era when I launched my 'gassie' career with a 7 foot Miss America powered by a kit assembled Bunch Aero. Carl's model shop faced Lane Tech across Western Avenue and with the school having an enrollment of 9000 male students (no girls then) there were many who benefited from Carl's help and example.

The Louisiana MD, Bob Lien, whom we met via these pages (May '64 RCM) and at last year's Dyna-Soarers meet in Houma, La., sends kind words about the column and news of an RC products firm he and Stan John, Jim (Beachcomber) Kirkland, and Les Sanborn have started. Custom RC Products, Bob's announcement says, is to be devoted to timely and useful items and should prove popular since this is an experienced group in RC who understands and know first hand of the particular needs of RC'ers.

Jack Henry, whose Veco Products firm is a by-word in RC and the modeling world, sends word back that his Veco #1 fuel is now available in gallons. This is good news to me since up till now all I could find were pint cans and at a 24 gallon per season rate which I'm using it was a mite expensive. Jack didn't know it but I guess I was his most loyal cus-

tommer, using #1 almost 100% for contest work because I've found it's dependable in all ranges and giving what I judged to be about 800 rpm more power than similar fuels. To stretch my short supply I've mixed it 50-50 with either Fox Superfuel, K & B 100, or Pink Lady, the popular name for Hi-Lo. A word of caution, #1 for some reason is different than any other RC fuel and when used straight softens Hobby Poxy! To really top the picture though, it least bothers butyrate finishes of any alcohol fuel I know. Figure that one! In any case, this fuel was a sleeper last season on the RC scene for various reasons (it's surprising how many dealers and fliers told me it was K & B 100 in another can) but now that it's available in RC sizes should become a standard along with the host of other Veco items. The tip-off on this fuel was its success in the 1963 International Championships at Genk. A close reading of details of the previous international meet showed idle failures as having a big part in costing us the team championship although Tom Brett had taken the top spot. Team scores are significant, however, since they 'indicate a broader average events' as a quality engineer would say, and when the 1963 team handily swept the meet by almost 1100 points with all using #1 in their Veco 45's (RCM Nov. '63, page 41) I was convinced the fuel had meant the difference to a large extent. Consequently I ran it in my Veco 35 without an exhaust restrictor (never use one with any fuel with this engine, although Duke Fox thinks it's nutty) and only hope to continue to get as good an idle next season.

The letter from Hank Shapiro of Sacramento, California is being referred to RCM's Bill O'Brien who'll look into a product review of the Sampey Starlite and Keystone single channel proportional systems Hank suggests. Hank is an RC newcomer and sends word of his first plane, an 049 powered Midwest Aeronca. Like all beginners, he has a problem deciding what equipment he wants but shows a healthy hunk of hesitancy about buying just anything. With some confusion resulting from pulsing and non-pulsing single channel equipment even experienced fliers aren't sure what's being offered in some ads. Hank, thanks for your good wishes. If you haven't done so as yet, it's a

good idea to have some local fliers help you check out your new ship. It's invariably best for a new RC pilot and plane to look to experienced hands for those first flights. Don't do as I tried — I can still hear the sound of the crash! So, guys, Hank lives at 2941 Marconi Av. (all RC'ers should live on a street with such radio distinction) — give him a hand, will ya?

A letter from Arlington State College and Don Downing brings us up to date on one of Wichita Falls' most active fliers. Don's interest in RCing led him to his study in electronics and brings to mind of course, an important reason for encouraging our younger people into the model plane hobby. While we're told that nowadays a lot of education is needed to succeed, sight is often lost of the necessity to have enthusiasm in important undertakings. In my book it's an ideal situation where a hobby can become a useful stepping stone to a fruitful and productive career by adding that important ingredient as well as a technical footing. Simply going through the motions of obtaining a degree without developing the spark and drive labelled 'enthusiasm' may lead to the abyss of mediocrity and the frustration of a limited fulfillment. It isn't intended to lecture here, but when a good look is taken of the something extra evident in our youngsters as they immerse themselves in the challenge of flight, creating with their hands, and in competition, we see the same dynamic element that brings forth leaders in all walks of life. When this is compared to the jaded many who somehow missed this fire, we adult members of this modeling world understand again the responsibility we have of keeping the hobby whole and available to young people in the hope of helping them to learn an important lesson of life. By example of honest fair play and just by making sure there's room and effort for them in our R/C sport is all it takes to give them that chance.

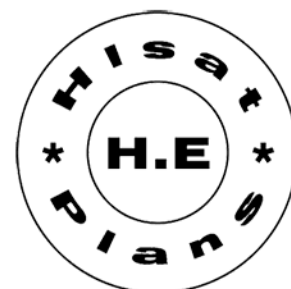

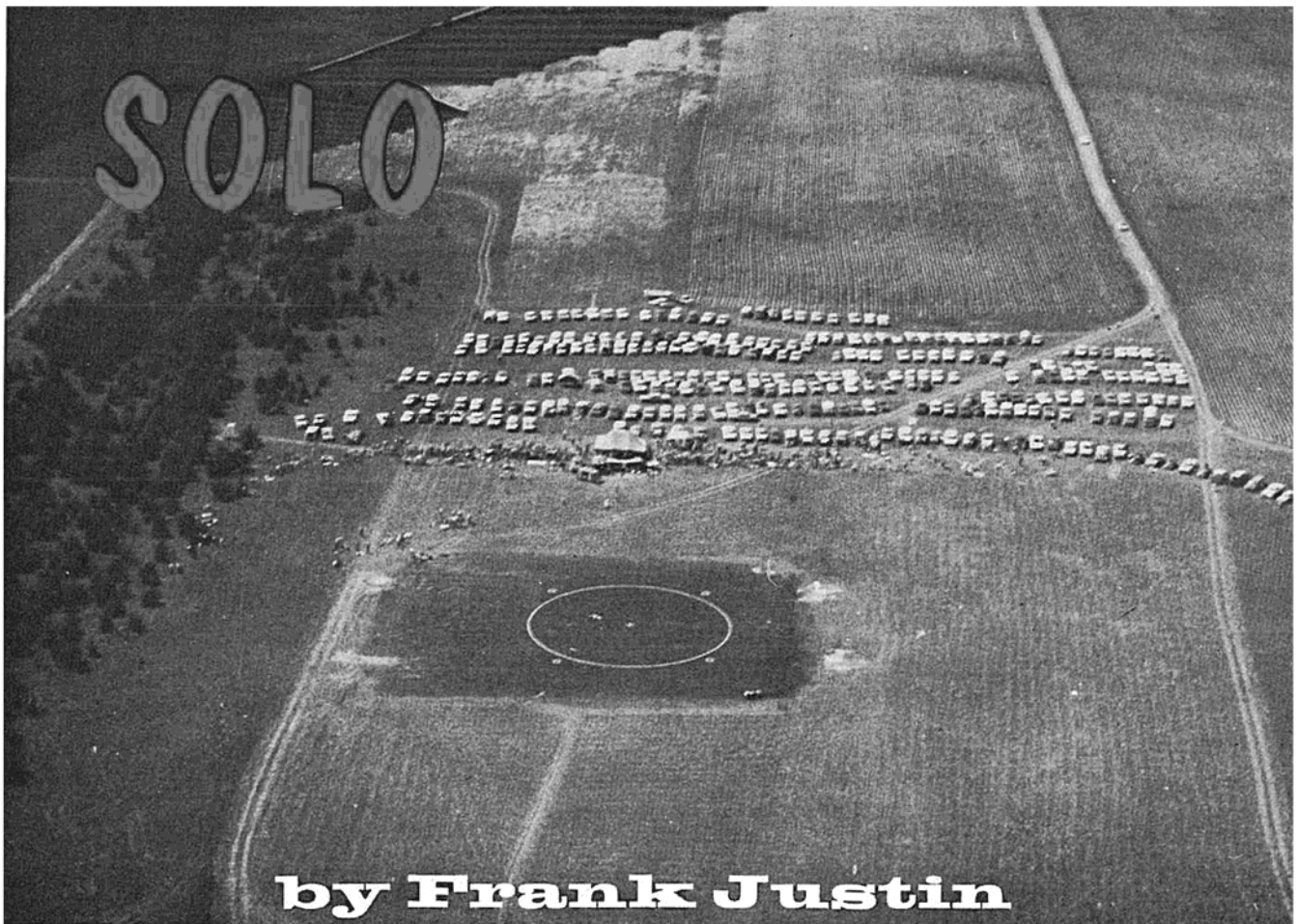

There have been many letters on the Orbit Proportional article, ranging from "it's about time someone had the guts to tell the truth", "to "what are you trying to do, run them out of business?"

The testing of the Orbit rig was my responsibility, so let me say a few words on the subject. The system was given by me to a flier that has no connection whatsoever with the magazine. The article was written by the editor from comments submitted to him about the rigs performance. I read the draft of the article and approved it. I did not, however, proof read the lead caption, quote — "Now the long awaited Orbit Proportional System is competing in the fastest growing phase of R.C. Will it make it or not?"

The phrase, "will it make it or not?", was, in my opinion, a mistake. It sets the tone for the article, leading the reader to believe that an opinion has been made and qualified. We are trying to bring you facts and let you form your own opinion. That phrase might be just right for Road & Track, but I hope that in the future we at

RCM stick to "just the facts, ma'am."

In our defense, however, let me say this. We have been told that our job is to sell merchandise for the manufacturer. We will go on record as saying that we have **no such obligation to any manufacturer.** We **do** have an obligation to the advertiser to supply readers and we cannot fulfill that obligation if we try to **show** our readers about any given product.

So, manufacturers — beware! If your product can't stand criticism, don't send it. And, from this point on, don't expect rave reviews. I understand that Kraft's production proportional system (one of a series!) is coming my way in a few days. It better be good — I'm in a critical mood!

We who live on the coasts of our country tend to get the idea that there is an imposing void between us, bisected by the Mississippi. As far as RC is concerned, it isn't so. Proof of this comes from some fine pictures supplied by Harley B. Hicks of the Twin Cities RC Club in Minnesota. I would like you to take note of the particularly fine field they enjoy. Also

note the fine public interest in effect as a photographer from WCCO-TV prepares film for a later showing of Larry Geld and a sharp scale Corsair. The Corsair was built using a basic Sterling kit and sports a Super Tigre .56.

From down South, Dick Thomas of Nashville sent an excerpt from a book entitled 'Building And Flying Model Airplanes', published by D. Appleton-Century Company in 1942. Dick picked this 242 page manual up in a used book shop, thinking it would be of interest to his 13 year old son, David. Possibly a bit of reminiscing on Dick's part, too, since he cut his teeth on a glue tube and his fingers on his fathers discarded Gillette's back in the middle '30's and early '40's. Dick felt the brief section in this 23-year old book on radio control might bring home to our readers the then undreamed-of advances that we present day RC'ers take so much for granted. As Dick puts it, "if progress continues at the same rate for the next two decades, we will probably sit in the den on Saturday and watch

(Continued on Page 12)

Solo

(Continued from Page 11)



our model go through the pattern with the transmitter keyed by a pre-programmed computer... viewing it on closed circuit T.V."

Anyway, along with a couple of photographs of Charlie Siegfried, then of Kansas City, with his monstrous RC job, and Bill and Walt Good with the Guff, here is the section on RC... as it was 23 years ago:

RADIO-CONTROLLED MODELS

A radio-controlled model is a gas powered plane with its flight path controlled by a radio-receiver mechanism which has been installed inside the fuselage. The radio receiver is motivated in turn by a radio transmitter located on the ground. There are no direct wire connections between the transmitter and the plane. Building and flying a radio-controlled

model is the most advanced form of activity in the model-airplane field. It should not be attempted until the hobbyist is thoroughly experienced in the building and operating of gas models.

Two hobbyists usually join together to build the radio-controlled model plane. One hobbyist is an expert radio technician. In addition to this, regulations of the Federal Communications Commission require that the operator of a radio-controlled transmitter must hold an amateur radio station license. Any one who operates the transmitter must have a licence issued by the Commission covering the operation of that particular type of equipment. The companion hobbyist, as already indicated, should be an expert with gas models.

Complete outfits and a generous assortment of parts, including radio-control receivers, may be purchased at model-supply stores. There are two types of receiver-control mechanisms in general use; one type of control operates the gas-model throttle and elevator, the other type operates the throttle, elevator and rudder. When the controls are in operation the receiving antenna picks up and conveys a tone signal fed into the selector circuit, which motivates a relay.

The control surfaces of a radio

model must be hinged and balanced so that they are moveable and can shift position according to the movement of the relay, which is controlled by radio impulses. Control wires run from the relay to the control surfaces. Any movement of the relay automatically changes the position of the controls. Only a small portion of the trailing edges of the rudder and elevator are moveable on radio models, these parts being cut and hinged as a tab.

Radio models are heavier throughout their construction than the usual gas models, inasmuch as the delicate equipment installed must be protected by structural strength. Landing-gear shock-absorbers should be particularly strong. Wing and tail areas, because of the additional load carried, are made larger in relation to the fuselage than on regular gas models of a similar size.

Almost all radio-controlled planes are built from original designs. This is because the fuselage shape depends largely upon the size and shape of the radio receiving unit. The flying qualities of the plane are usually tested by taking a weight equal to the weight of the receiving set and installing it in the plane at the exact point where the receiving set is to be installed. The plane is then tested in flight. This procedure is generally necessary in order to safeguard the receiving set against the possibility of damage during test flights.

In contest competition for radio-controlled models there is no restriction on the length of time the motor runs. Performance is based not on the length of time the model remains in the air, but on the degree of control exercised by the operator. With continued practice and all mechanical parts working well, an operator can make his craft execute almost any maneuver which can be performed by a full-scale airplane such as climbs, turns, loops and figure eights. The model should be in complete control at all times and be brought to the ground at the will of the operator.

The successful building and operating of radio-controlled models requires the utmost in cooperation between builder and radio expert. Once success is achieved there is no more enjoyable sport and hobby than flying a radio model airplane.

So, how about that, RC'ers? Think it's rough, today?

See you at the field.

WCCO-TV newsman prepares video tape of Larry Geld and his scale, re-vamped Corsair.

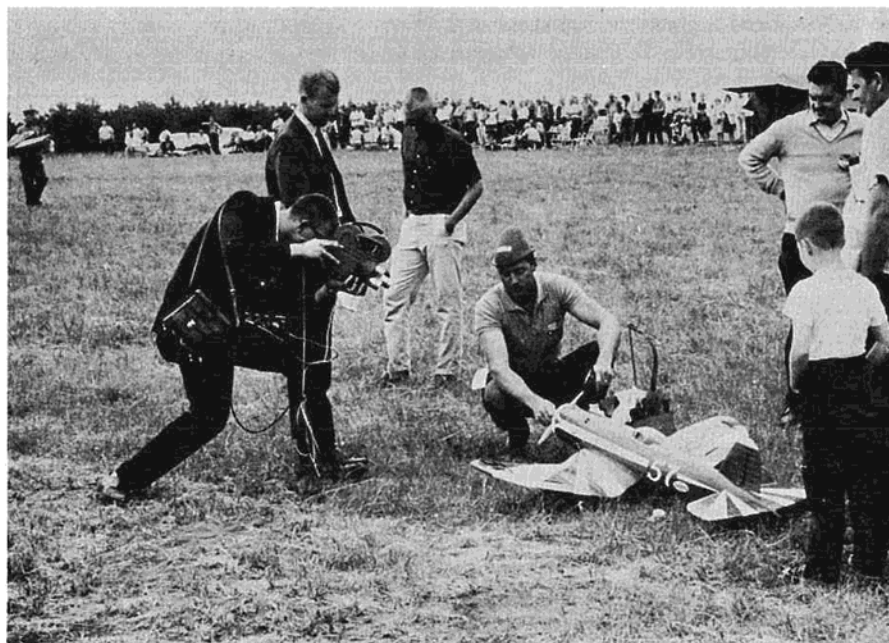



Top honors this month goes to D. F. Bryant of London's Bromley R/C Club for his 54" Hawker Fury. This eight and a half pound scale ship uses a Merco 61 for power. F&M radio equipment with Bonner servos. Front part of the fuselage is of fibreglass with chrome vacuum plating. Markings are from R.A.F. Squadron No. 43. A magnificent ship.

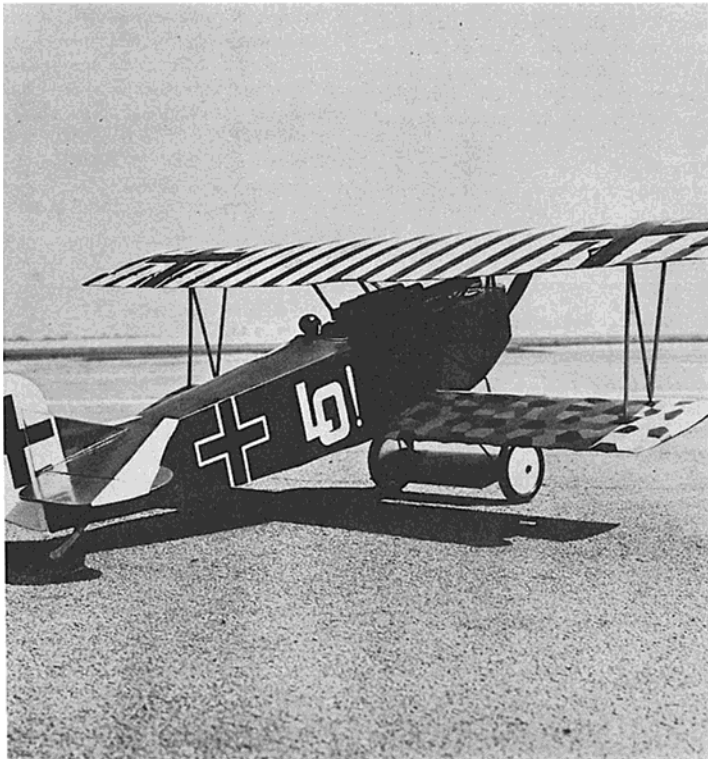

Another biplane — this time, F.A.S.T. Club member Chuck Coryell's World War I Fokker D-7, mistakenly attributed to the Williams brothers when it appeared in color on the January issue of R/C Modeler. Chuck's scale ship spans 57", uses a Supre Tigre .56 for power. Orbit reed equipment. Photo by Les McBrayer.



John Jennings, National record holder for Junior Pylon, scored second in Pylon, third in Class III, and third in Scale at the Space City International at Houston, Texas, November 28-29. What is most amazing about this latest collection of hardware is that John won them all in Open Class competition! Quite a birthday celebration for John who was thirteen on November 26, 1964! Our congratulations to a real competitor!

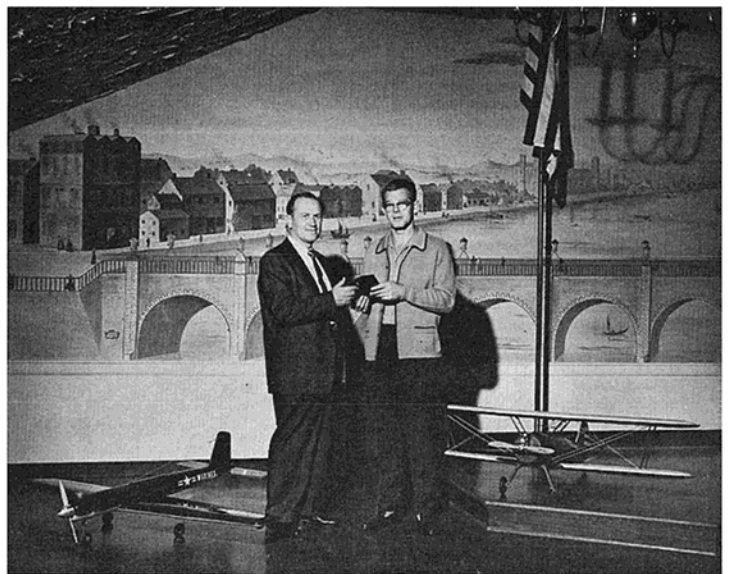

One of the activities the Garden Grove R/C Club of California prides themselves on, and justly so, is helping beginners. The Garden Grove group presented their V.P., Louie Zienniker, with a plaque for his contributions in this field. Louie has often had as many as five beginners in the air at once, running back and forth between them! On the left, GGRCC prexy Marvin Powers.

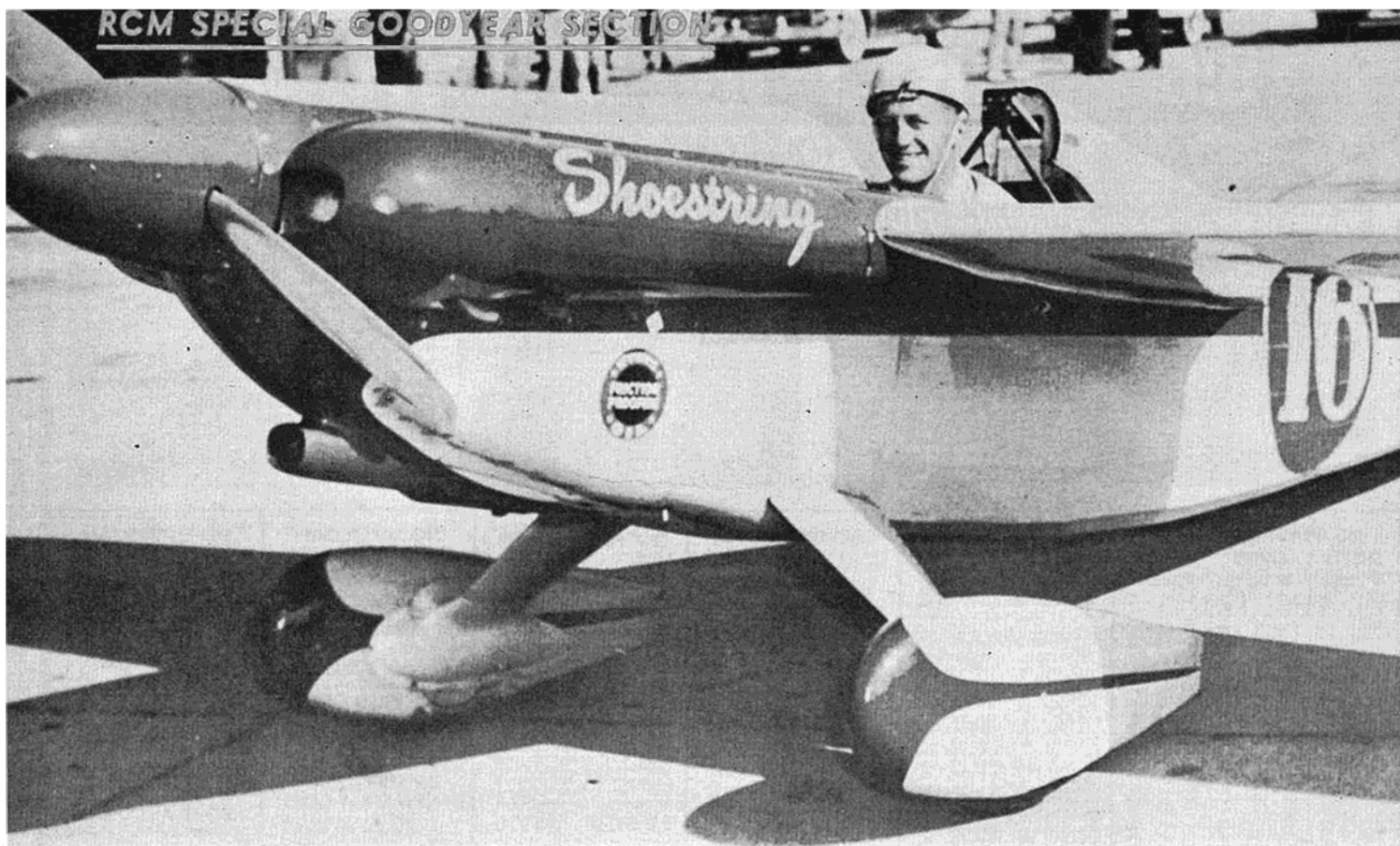

Altitude: 30 FEET Speed: 200 PLUS

Three-Views and photos courtesy of Floyd Clymer Publications

The loudspeaker barks. "All Goodyear participants... planes and crews on the ramps."

The waiting and wondering is about over. This is what you've been working for all year, preparing your five hundred pound airplane for this afternoon's event. It's shortly past noon and the grandstands are filled to capacity with spectators tense with anticipation. Only a few minutes to go.

Your quick lunch is merely a matter of habit. The last bite of the vending machine sandwich is washed down with a Coke, and it's like a ball of cotton in your throat. You shield your eyes from the midday sun and glance toward the pylons on the two mile straightaway and rectangular course. A breeze has come up and the brightly colored checkered fabric slaps against the tubular framework of the twenty-five foot high markers. You note that the judges have already taken their places in the flag draped

bases of the pylons and wonder, with a grin, if you can make them duck this year.

As you light a cigarette you hear a spontaneous murmur rise from the grandstands, then a smattering of applause as the first of the brightly-colored midgets is wheeled on parade past the spectators, then toward the starting ramp. Mentally, you review the results of yesterday's heats. The Cosmic Wind from Phoenix was a half mile per hour faster than your own ship... the kid from San Diego weighs thirty pounds less than your own 155 — quite a difference to a five-hundred pound ship, especially on takeoff... and then there is the highly maneuverable low wing design from Florida that pushed you on the last pylon, going under your ship when you rounded the marker too high...

You drop your cigarette butt in the soft dirt and nervously grind it out with your heel. Glancing up you notice all the planes are on the mat.

You reach for your crimsoned emblazoned crash helmet and walk toward the small group of pilots gathered around the race referee.

A few last minute details... press photographers flashbulbs blinking away... then you're strapping on your 'chute pack and squeezing into the tailored cockpit of your midget. Pull the shoulder straps down and buckle the seatbelt, then slide the canopy closed over your head. The mechanic, standing in front of the ship, flips the prop over, and the 85 h.p., 175 pound racing engine roars to life. As you warm up the motor with a fast idle, the cockpit begins to get uncomfortably hot from the midday sun. Suddenly the starters white flag goes down, signifying one minute to start — you increase the rpm and a few seconds later the flagman rises. As the crewmen hang on to the wing-tips and tail of the ship, fighting the

(Continued on Page 15)

prop wash, you increase the throttle, until, at the second the starting flag goes down, you have full rpm. The crew releases their hold and the midget shoots forward with a surge that sends you back into the seat. In a matter of seconds you're airborne and screaming towards the first pylon. You've got the lead... you calculate the pylon position so as to cut one of the markers... around the first pylon and into the straightaway... you're doing slightly over two hundred miles per hour now and you glance down at the shadow of the planes on the ground a scant fifty feet away... your arms and back ache and you're perspiring... the second pylon is coming up...

The design and racing of midget aircraft around a pylon course in front of a grandstand full of spectators was first considered just after

the annual National Air Races.

The specifications were rigid, to say the least. The original design specs called out a single place aircraft with CAA-approved Type Certificated engine with maximum cylinder displacement of 190 cubic inches. Maximum wing loading, based on the gross weight, was 12 pounds per square foot. Minimum empty weight was 500 pound plus or minus one percent. Mechanical specifications included a fixed pitch prop, non-retractable landing gear, fifteen gallon fuel tank, minimum vision requirements for the pilot, plus approval of the design drawings of any given plane by the Association Technical Committee prior to construction. In addition, upon completion of construction, the racer had to be demonstrated before the Technical Committee at high altitude to assure not only the airworthiness of the craft, but also that all safety

changes were laid down by the PRPA, including a minimum wing area of sixty-six square feet; permission to use flaps, plus improvements to the specifications for pilot visibility. The latter included a 270 degree field of vision in the horizontal plane, 140 degrees from the top of the cowling in an upward and rearward direction; 25 degrees from the pilots line of sight to the top of the leading edge of the wing at the fuselage, and five degrees down to the top of the cowling. The cockpit canopy itself had to provide a minimum of six inches from the pilots eye level to the top of the enclosure when in normal seated position and must allow the pilot to turn his head sufficiently to attain the specified field of vision.

Following the 1948 events for the 190-inchers, the Continental Motors Corporation Trophy Race at Miami and the Goodyear Trophy Race at

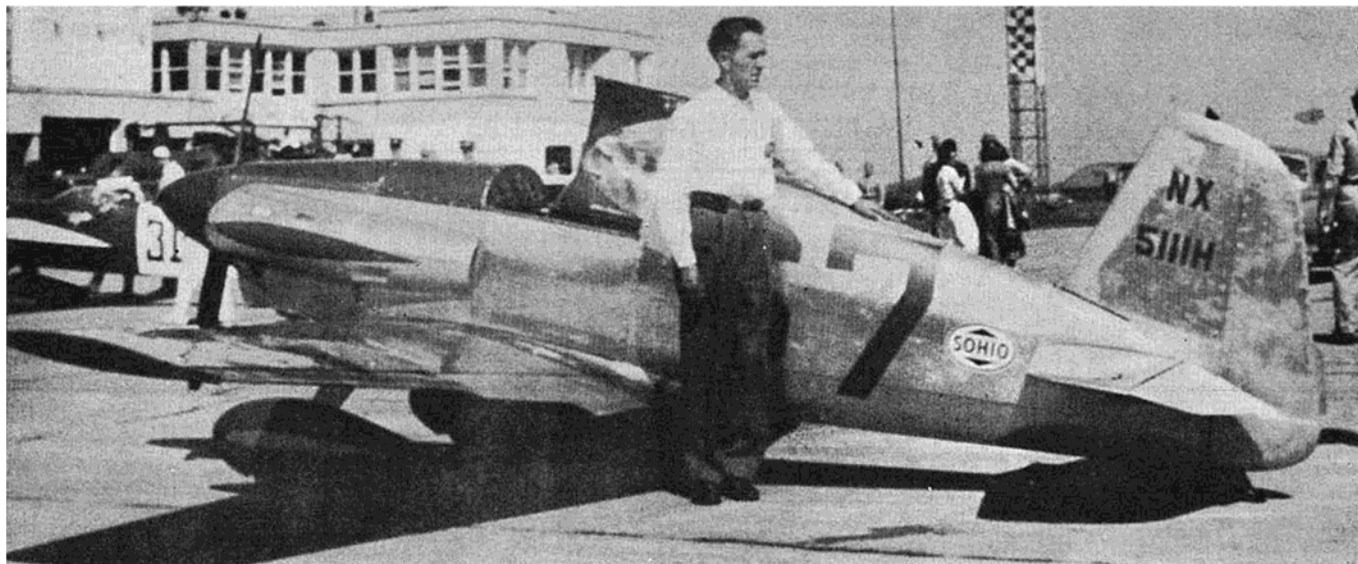

Luther Johnson's Long Special. Photo by J. L. MacKenzie

the Cleveland National Air Races in 1939, although no major steps were taken toward this proposed event until the conclusion of World War II. The original specifications for the 190 cubic inch class of racing, or "Goodyear racers", were developed by Art Chester, president of the PRPA (Professional Race Pilots Association), Jacqueline Cochran, Roger Kahn of Grumman Aircraft, Harry Bruno, Ben Howard, and Clarence O. Bell of the Goodyear Tire and Rubber Company. These initial specs were submitted to the NAA Contest Board and approved in the latter part of 1946. The Goodyear Corporation followed this approval with the posting of \$25,000 in cash prizes for each of the years 1947, 1948, and 1949, to be awarded at the conclusion of

factors had been met, prior to allowing the plane to perform at low altitude and high speeds before spectators. Insofar as the pilot was concerned, he was required to have a minimum of five hundred solo hours or, alternately, 200 solo hours plus thirty hours in the actual ship to be flown at the race.

The 190 c.i. motors were not allowed to be altered, either structurally or otherwise, except as approved by the manufacturer. Ports could not be enlarged, but could be polished. Any new engine used in a racer had to be manufactured in sufficient quantity to be available to all in order to qualify for approval, thus eliminating "custom engines".

Following the first Goodyear event in 1947, additional rules and/or

the National Air Races in Cleveland, additional slight modifications were made to the existing specifications. These included a recommendation that dynamic, or static balancing, of ailerons be accomplished, a ruling that became mandatory following the 1949 events, which included the Continental Trophy Race at Miami, the Goodyear Trophy at Cleveland, and the Rebat Midget Plane Race at the Reading Air Show. Also effective, following the 1949 classics, were the rulings that permitted the use of a single type fuel of any octane rating, forced draft ventilation of cockpits, and a safety rule that established a minimum altitude requirement of fifty feet.

The Goodyear Racers, overall, have

(Continued on Page 16)

RCM SPECIAL GOODYEAR SECTION



Keith Sorensen's 'Mike Argander Special'. Photo by J. L. MacKenzie

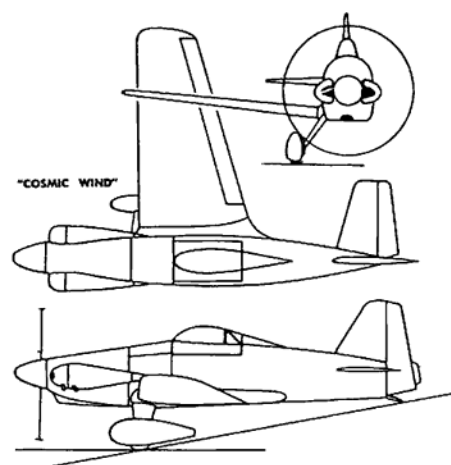
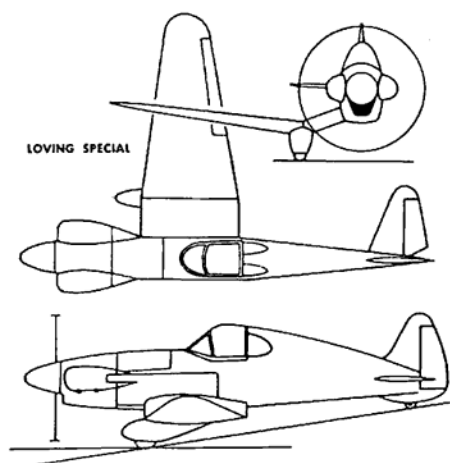
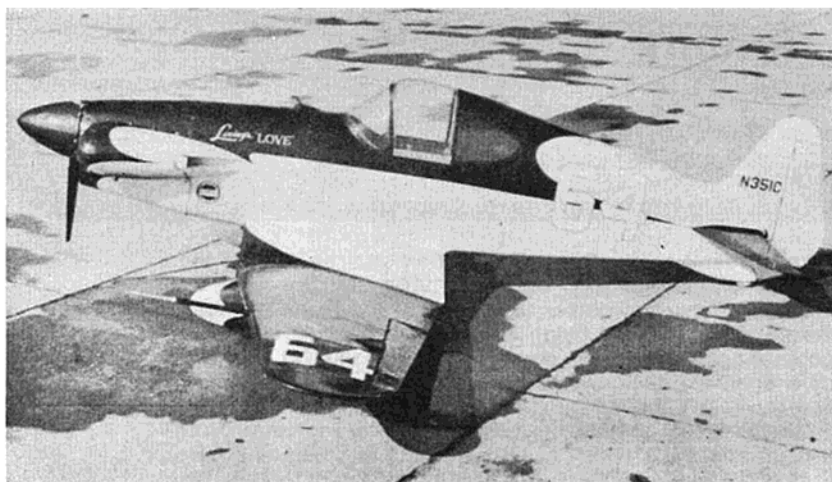

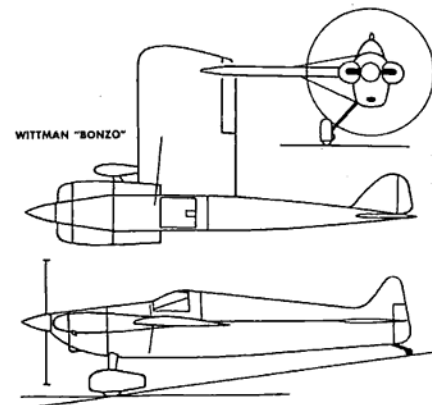
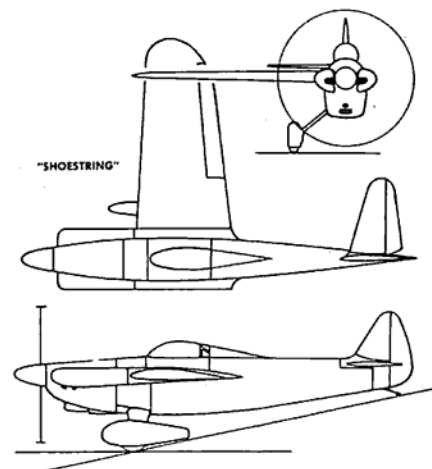
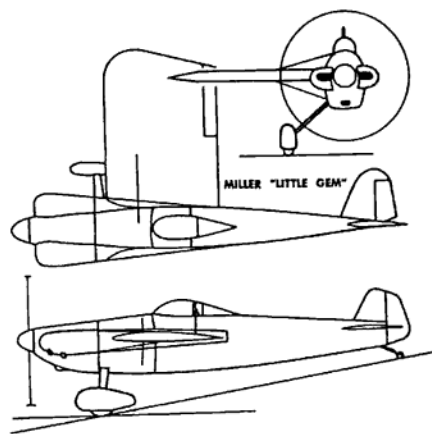
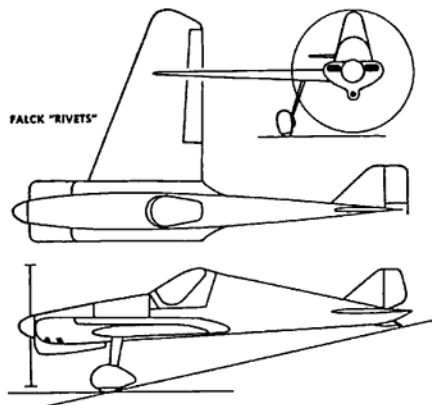

gained the most popularity of all American racing aircraft. Generally speaking, these cameo racers were custom built jobs powered by four-cylinder 85 h.p. Continental engines, weighing in the neighborhood of five hundred to seven hundred pounds, with a maximum straightaway speed of approximately 200 m.p.h. (in 1948), and a landing speed of about 75 m.p.h., constructed at a cost of about \$5,000.

With the revival of air shows and midget air races, and with the current tremendous upswing of the interest in this phase of aviation, and in the interest of the RC'er contemplating building a miniature Goodyear racer to compete in 1965 under the NMPRA rules, we present the following data, details, and three views of some of the famous full-sized ships that competed for the midget racing trophies.

Racing No.	Registration	Plane	Span	Length	Colors
8	N1961M	Lil Monster (Pitts Special)	15'- 6"	15'- 5"	Red, cream
5	N22C	Ballerina (Cosmic Wind)	19'- 0"	16'- 0"	Green, chartreuse
9	N9N	Mammy (Long Midget)			
31		Skeeter			Red, white
67	N6V	Long Midget			Alum., maroon
3	N20C	Little Toni (Cosmic Wind)	19'- 0"	16'- 0"	Maroon, cream
94	N35C	Little Mike	20'- 8"	15'- 0"	Blue, gold
27	N32C	Mr. Zip			Light, dk green
97	N9059N	Denight Special	18'-10"	17'-11"	Yellow
4	N21C	Minnow (Cosmic Wind)	19'- 0"	16'- 0"	Bronze, cream
74	N426A	Mr. D			Met. blue, white
63	N5541N	Anderson Speial	15'- 0"	16'- 6"	Yellow, red
33	N58915	Dawson Special	16'- 0"	17'- 6"	Green, yellow
94	N68732	Foss Special	20'- 8"	14'-11"	Aluminum, maroon
50	N60298	Shroeder Dragontail	20'- 0"	10'- 0"	Aluminum, red
51	N2E	Carolina Aviation	16'- 6"	16'- 4"	Red
92	N60089	67 Falck Special	17'- 8"	17'- 0"	Silver, red
67	N51114H	Long Midget	18'- 6"	16' 0"	Blue, cream
48	N33N	Northrup Special			Aluminum
16		Bell of Bethany			Red, black
64	N315C	Loving-Wayne WR1	20'- 0"	17'- 6"	Maroon, cream
39	N24C	Sorensen Mike Ardander Spl.	18'- 6"	15'- 6"	Black, white
31	N31C	La Jollitta			Red, white
77	N42N	Li'l Spook	16'- 0"	17'- 0"	Gray, black
84		Thompson-Balboni Special			
34	B44183	Estrellita	19 ¹ / ₂ ' 0"	16'- 5"	Yellow, black
59	N5713N	Zipper	16'- 0"	16'- 0"	Yellow, red
40	N1210M	Sreamin Meany (Thompson Special)	17'-10"	16'- 0"	Yellow, red
51		Johnson Special			
35	N70E	Coonley Special	18'- 6"	18'- 0"	Orange
29	N138C	L.I.T. Special	20'- 0"	20'- 0"	White, blue
10	N1E	Falcon Special	17'- 2"	17'- 6"	Blue, cream
22	N7E	ibbs Special	19'- 0"	19'- 0"	Lt., dark Green
47	N66317	Li'l Rebel	17'- 2"	16'- 0"	Yellow, blue
42	N3154K	Mirage	18'- 7"	17' 5"	Maroon
92	N6099	Rivets	18'- 0"	17'- 0"	Red, yellow
30		Miss Dara	16'- 7"	18'- 4"	Yellow, blue
16	N26C	Shoestring	15'- 0"	19'- 0"	Cream, red
1	N1292	Bonzo	15'- 4"	17'- 6"	Yellow, blue
14	N5623N	Miller Special	18'- 7"	17'- 0"	Gray, red
15	N6H	Stoppelbein & Ohm Special	20'- 0"	16'- 0"	Red, black
46		Johnny Reb	15'- 0"	16'- 0"	White
111		Cassut Special	14'-11"	16'- 0"	Yellow
20	N14855	Wittman Special	16'- 0"	17'-10"	Red
		Buster			
2	N4000K	Swee-Pea	18'- 6"	15'- 7"	
87	N9052Z	PAR Special			
14		Li'l Gem	15'- 0"	17'- 0"	Gray, red

RCM SPECIAL GOODYEAR SECTION

THE N.M.P.R.A. *and the Year's HOTTEST Event*



The proposal by a group of fliers in the Northern California area for a miniature pylon race event, patterned after the famous Goodyear Racer events of the 40's and 50's, may well become the most popular class of RC competitive flying. With over twenty-five scale Goodyear racers preparing to compete in the first contest sponsored by the newly-formed National Miniature Pylon Racing Association at Turlock, California this coming March, more and more fliers through out the country are applying for their racing numbers. Each of the Goodyear type racers, scaled 2 $\frac{5}{8}$ " to the foot, carries the assigned racing number plus the individual' contestant's AMA number prefixed by the letter "N". This month's issue of RCM carries the plans for Joe Martin's Denight Special, designed specifically for this event. Jerry Nelson's "Li'l Knarf" is scheduled to appear in the near future in another model publication.

Inasmuch as the January issue of RCM carried the initial objectives of the NMPRA, plus the suggested course, we assigned two RCM staff members to fly to Northern California to photograph and obtain details on the Goodyear racers presently flying in that area. After seeing them perform, and after handling the con-

trols, we can safely predict that this new event is destined to become one of the most popular categories in model aviation. Whether on proportional or reeds, these ships are excellent fliers — either for sport or competition under the new pylon rules. In the air, they are realistic, both in appearance and flight characteristics. In the pylon course, they offer all of the thrills and excitement of the cameo air races held in the post WW II era. Imagine, if you will, three or four of these .40 cu. in. sized ships rounding the triangular course together, a scant few feet above the ground! For spectator and contestant alike, an all new thrill to an already exciting hobby!

The following rules are those proposed by the NMPRA — those individuals and clubs interested in participating in this event, and wishing to be assigned a racing number, are asked to write to the NMPRA, c/o R/C Modeler Magazine, P.O. Box 487, Sierra Madre, California. As soon as the organization of the Association is completed, full details will be sent in response to each inquiry. Full size plans for the Lil Knarf, Little Toni (Cosmic Wind), Bonzo, and Rivets are available for \$3.00 each from the association. It is also hoped that the new Goodyear

Above: Jerry Nelson's "Bonzo" topping the pylon. Left: The Bonzo heads home after the day's races, the evening sun glistening from one wingtip.





Jerry Nelson's all-yellow 'Bonzo' in foreground — Joe Martin's 'Denight Special' in the rear. All-blue 'Denight Special' is featured in this issue of R/C Modeler.

event may become a part of the Nationals competition, beginning as an unofficial event during the final week-end of the annual affair.

Looking for something new and exciting in R/C? Try the Goodyear racers.

NATIONAL MINIATURE PYLON RACING ASSOCIATION OFFICIAL RULES FOR 1965 SPECIFICATIONS FOR .40 CUBIC INCH CLASS RACING AIRPLANES

These specifications are the only official and approved regulations for the 1965 .40 cubic inch class of racing models. Therefore, they supercede those published previously.

OBJECTIVE

The purpose of this event is to cover the prescribed course at the highest possible rate of speed with a radio controlled model airplane patterned after the 190 cubic inch class racing airplanes commonly known as the Goodyear pylon racers. Race results will be posted in miles per hour.

GENERAL

All AMA and FCC regulations covering the R/C flier, his plane and equipment, shall be applicable to this event, except as noted herein. There shall be no limitation on the type of equipment fitted to the plane, or the number of controls. The owner of the model shall be allowed two entries, in this event. The owner can only use his alternate model if the first model is not flyable. Only the first model will be processed. Only if the first model is not flyable shall the second model be processed. The owner may have someone else fly his model in competition if he desires to do

Combining scale-like appearance with realistic flight performance, the Goodyear event designs are excellent sport fliers on proportional or reeds.

so. However if this is done, the model will be entered as a team. Both the owner and pilot shall have current AMA sporting licenses.

Considerations of safety for spectators, contest personnel, and other contestants are of the utmost importance in this event. Any flying over a controlled spectator area will be cause for immediate disqualification of that flight.

ENGINES

Total piston displacement must not exceed .40 cu. in. Engine must be a stock production engine that has been produced in quantities greater than a hundred units. Any changes other than modifications or changes in the throttle mechanism will not be allowed. If any changes are found the entry is subject to disqualification. The engine will be equipped with a operating throttle that will allow the model to taxi at a rate of speed less than a fast walk.

PROPELLERS

Must be fixed pitch in flight. Adjustable

(on the ground) type may be used. Any type of material that is deemed safe may be used.

FUEL TANK AND FUEL

Must have a minimum of 4 oz. capacity but need not be filled to capacity. Only commercially available fuels may be used.

FUSELAGE

The fuselage will have a minimum outside width of 3½ inches at the location of the pilot. The ship will have a minimum height of 7 inches at the location at the pilot. The engine will be at least partially cowled with a minimum of ½ the bottom of the crankcase hidden.

SPINNER

The model will have rounded propeller spinner of at least 1½" diameter. This applies to a conventional tractor engine installation.

LANDING GEAR

Non retractable type. Wheels must be 2¾ inches in diameter or larger. At least

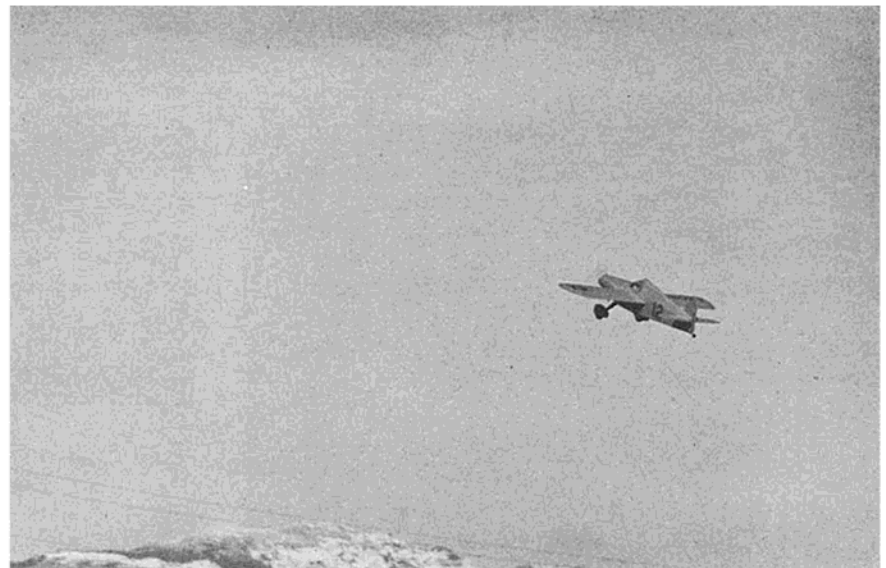

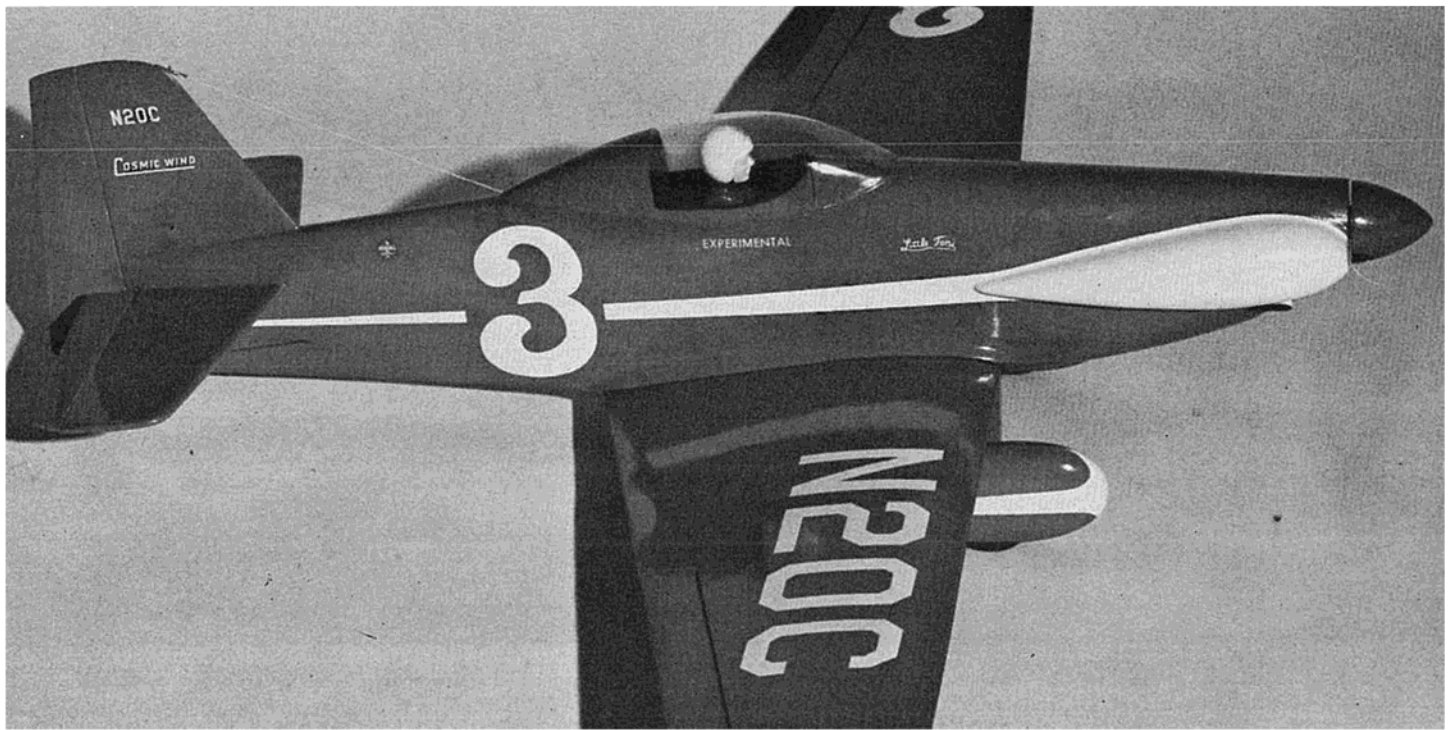

two wheels of the specified size must be used. Auxiliary or third wheel on tricycle type may be of any size but not retractable. A positive means of steering on the ground will be provided.

COCKPIT

A scale like cockpit will be provided. A solid or painted cockpit canopy will be allowed. The canopy outline will be such to allow a scale size pilot whose head size is 2 inches from his chin to the top of his head. There will be a clear forward and side vision of the pilot at least $\frac{3}{4}$ inches from eye level to the top of the enclosure with a pilot in normal sitting position. A pilot need not be installed.

WINGS

Minimum of 450 sq. in. of wing area must be used, including that area displaced by the fuselage, but not including fillets or stall strips. Flaps are permitted but wing area is to be figured with flaps retracted. Maximum span will be 54 inches.

WEIGHT

Weight less fuel but including all equipment necessary for flight will be at least $4\frac{1}{2}$ pounds.

RACING NUMBERS

Racing numbers may be obtained from

the National Miniature Pylon Racing Assoc. secretary. The use of these numbers is highly recommended. The numbers are located on the upper left and lower right hand wing panel facing towards the left side. The number will be right side up with the model in a left bank. The numbers will be at least 3" high on the wings.

REGISTRATION NUMBERS

A registration number is required on the upper right and lower left hand wing panel. The same number is also required on the vertical tail surfaces. The minimum height of the numbers on the wing will be 2 inches. The minimum height of the numbers on the vertical tail surface will be $\frac{1}{4}$ inch. The letter N will precede the registration numbers.

An alternate method will be placing a minimum of 1 inch numbers along each side of the fuselage behind the trailing edge of the wing.

Suggested registration numbers are the entrants AMA number. If the entrant desires he may use the last two or three numbers of his AMA number followed by the initial of his last name such as, N204D.

MATERIALS AND WORKMANSHIP

Workmanship must be of satisfactory

standards. Contest committees are empowered to refuse permission to fly, or to qualify any ship which in their opinion, is not up to reasonable, safe standards in either materials, workmanship, detail design, radio installation or condition as a result of damage.

INSPECTION

The winners of the first three places in the finals of each series of races can be subject to impounding immediately following the race and will be inspected by the contest committees. Ships with engines found to be altered will be disqualified and appropriate action taken against the owner and/or pilot, or both.

FLIGHT REQUIREMENTS

Before attempting to enter a competition the pilot must have flown the ship before two witnesses who are members of the AMA and demonstrated the following maneuvers before them.

1. Take-off at full throttle without veering more than 10 feet from either side of a straight line on the ground directly into the wind.
2. Pull-up from straight and level flight



The 'Bonzo' with new Orbit 3-channel proportional.

The N.M.P.R.A.

(Continued from Page 20)

at maximum airspeed and RPM into a full up elevator loop.

3. Make a dive at a 30 degree angle for at least a length of 500 feet.

4. Make a 180 degree turn at full air speed and maximum RPM without any appreciable loss of altitude or control.

5. Make three laps of a simulated race course at normal racing altitude, making the turns at full speed as in a race.

HANDICAP SYSTEM

A handicap system will be used to provide a bonus time in the issuance of up to 30 seconds head start for a scale miniature racing model of a 190 cubic inch class racing airplane. Points will be given that will correspond to seconds of headstart.

Handicap System for Scale Models of 190 Cubic Inch Class Racing Airplanes.

1. 10 points will be given for appearance, (5 points for workmanship, 5 points for finish). Models shall be judged for appearance complete and ready to fly. After model has been judged, nothing will be removed from or added to the model, which in the judges opinion, changes in any manner the appearance of the model from the way it was when presented for appearance judging. Wheel pants may be removed if in the contest committee's opinion the flying fields condition is such that damage would occur to the wheel pants if they were used. Appearance judging will take place before contestant's first flight. Judges should exercise prudence in assigning points, and reserve excellent point values for those models which are decidedly above average.

2. 20 points will be given for fidelity to scale. Proof of exact scale is the responsibility of the contestant. In order to obtain maximum points the entrant must supply accurate 3 views and or photographs of the subject airplane. The awarding of the points will be done on a 100%, 50%, 0% basis. The total number of points will be equal to the number of seconds headstart handicap.

- a. Fuselage and Landing Gear Group — 8 points
 - Side view outline4 pts.
 - Cross section1 pt.
 - Cockpit detail1 pt.
 - Cowling of engine1 pt.
 - Landing gear and wheel pants 1 pt.
- b. Wing Group — 5 points
 - Outline3 pts.
 - Control surface outline1 pt.
 - Dihedral1 pt.
- c. Stabilizer Group — 4 points
 - Outline3 pts.
 - Control surface outline1 pt.
- d. Rudder and Fin Group — 3 points
 - Outline2 pts.
 - Control surface outline1 pt.

3. Note that no points are awarded for a scale type finish. Scale paint trims are not encouraged because of repetition of duplicate airplane designs. Likewise the scale racing numbers need not be utilized. Therefore no bonus points will be obtained for a scale paint job nor will the entrant

be downgraded for a non scale paint job.

4. It is the intent of these scale bonus points to encourage realism in the models. The models are not to be judged for exact scale as in a flying scale competition at a Nationals. The judges will be lenient as possible but still leave room for the better scale airplanes.

5. Appearance is not a factor in the fidelity to scale judging.

Handicap System for Nonscale Type 190 Cubic Inch Class Racing Airplanes

A non scale type model is defined as one which receives zero for scale outline points in any of the four groups fuselage, wing, stabilizer, rudder and fin). 15 second handicap is possible.

1. 5 points will be given for appearance. (2½ points for workmanship and 2½ points for finish). Judging methods that are used for the scale model appearance division will apply.

2. 10 points will be given for realism towards approximating a original 190 cubic inch racing airplane design. The point system is awarded on a 100%, 50%, 0% basis. The total number of points will be equal to the number of seconds headstart handicap.

- a. Fuselage and Landing Gear Group — 5 points
 - b. Wing Group — 3 points
 - c. Stabilizer Group — 1 point
 - d. Rudder and Fin Group — 1 point
3. The appearance is not a factor in the realism to scale judging.

4. If the entrant has an unconventional type of nonscale design, he must show proof of an actual full scale 190 cubic inch racing airplane that is similar to the ship under question. The entrant can use a wing configuration from one scale design, a fuselage from another, a tail group from another, and a landing gear configuration from still another design. A combination such as this will pass without any question.

5. Biplanes or Deltas are not allowed unless the entrant can show proof of a actual 190 cubic inch racing airplane of this type.

6. Any ship that receives less than 6 points towards realism will be subject to disqualification because of not meeting the intent of the rules.

RACING COURSE SPECIFICATIONS

The course will be laid out as follows:

The course is 10 laps with individual lap lengths of ¼ mile. Total distance traveled is 2½ miles (13200 ft.) Race starts at the start finish line. All takeoffs will be unassisted ROG. The race is terminated at the start-finish 10 full laps later.

Operation of the Race — A suggested method would be as follows.

At the number 1 pylon there will be an official flagman per entrant. It is suggested that the official flagman will have a colored flag corresponding to the frequencies the pilots are using. The officials at the number 1 pylon will stand perpendicular to the direction of the course on the right hand side of the pylon no more than 15 feet away from the pylon.

It will be required that all models are to be flagged after they pass the number 1 pylon and not before. There will be no flagging at the number 2 and 3 pylons unless a pylon is cut. There will be no

pilot's helpers at any of the pylons.

At the number 2 and 3 pylons the official flagman will stand in close proximity to the pylons they are judging. If sufficient personnel are not available to act as flagman for each entrant, one flagman can be used at each of the number 2 and 3 pylons. He will use an appropriate method to notify a missed pylon to the flier in question.

A maximum of 4 planes per heat will be allowed.

A minimum altitude of 25 feet will be strictly adhered too. Any violation of this minimum altitude by the pilot will bring cause for disqualification by the contest committee.

A three minute time limit for starting the engine will be allowed. A 6 minute flight time will be the maximum endurance of any flight. Any time over that will be disallowed and not counted.

All laps are to be flown counterclockwise with turns to the left.

If the model fails to fly outside the pylon it must recircle the missed pylon, immediately or the flight will not be scored.

NOTE

The guide for these rules is patterned after official NAA 1949 specifications for 190 cubic inch class racing airplanes. The source of reference was, **National Air-Race Sketchbook** by Buehl and Gann, published in 1949 by Floyd Clymer.



RCM SPECIAL GOODYEAR SECTION



JOE MARTIN'S

DENIGHT SPECIAL

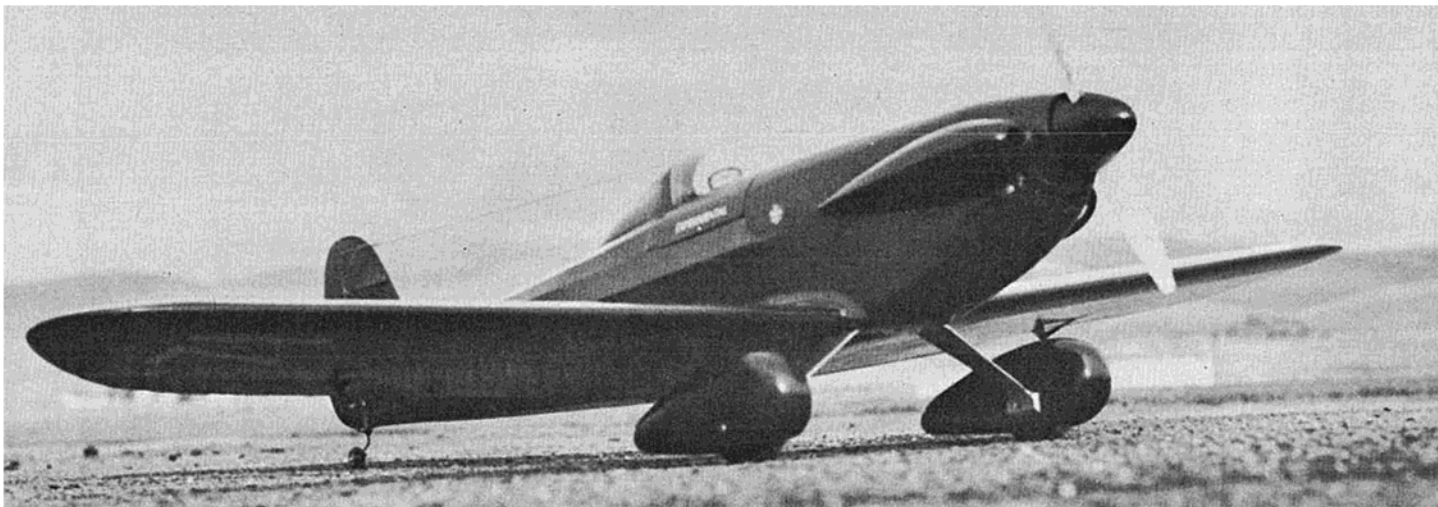

If you have already taken a close look at the plans for the Denight Special, you've probably noticed that they contain the phrase "—This model is designed to conform to the scale section rules of the National Miniature Pylon Racing Association." This issue will tell you quite a bit about the N.M.P.R.A. and its objectives — and about a racing event based on Goodyear type pylon racers that will probably be the greatest thing that has happened to R/C since the advent of multi equipment Imagine, if you will, four Goodyear type racers going down the straightway of a pylon course... a Bonzo, a Shoe-string, and a Cosmic Wind... being lead, of course, by a Denight Special!

As an added bonus, these ships are excellent Sunday fliers, have enough room for almost any type of R/C gear, and are a radical departure from the tiresome run-of-the-mill multi design. In brief, they look and fly like their full-scale counterparts, and are designed for an event that captures all the thrills and excitement of the famous Goodyear event.

If I have convinced you to build

a Goodyear racer for the new event, I think you would find the Denight Special an excellent choice. The full size prototype was owned and flown by William "Bart" Denight, had a wingspan of 18'10" and a length of 17'11". It's racing number for the Goodyear-Continental Midget Race was #97, and its registration N9059N. The all yellow ship qualified at 189.7 m.p.h. and took second place in the second heat at the 1949 National Air Races at Cleveland.

Construction

Fuselage, Stabilizer, and Vertical Fin. After building about fifteen stunt ships, I found myself quite tired of the usual type of construction, so decided to change the method of building the fuselage to something more scale for this particular design. It has worked out quite well, came out lighter, and was an enjoyable departure from the more conventional construction. I think you will find it interesting to build.

Study section AA and BB on the drawing, for these section views best explain the typical construction methods. First build the left hand side of

the fuselage on the plans using hard $\frac{1}{4}$ " square stringers. Now build the left side on the reverse side of the plans. Don't forget they are different. Next, add the $\frac{1}{8}$ " sheet sides to the forward areas of both sides. Add the $\frac{3}{16}$ " square stringers. For maximum appearance, it is imperative to keep the stringers sharp and free from dents.

The next step is to bend the fuselage sides to their approximate shape as shown in the top view. Add the $\frac{1}{16}$ " doublers. Sand the proper angle on the aft section of the fuselage sides and they are then ready to join together. This is accomplished by pinning the fuselage sides to the top view on the plans and joining them together with F2 and $\frac{3}{16}$ " square cross pieces as shown. Extra cross bracing will have to be used to hold the fuselage to its correct shape until the blocks are glued in place. These can later be removed.

The landing gear block can be added at this time — this is simply a 1" block with plywood glued on both sides. The wing is notched to receive this block, so that when the

Photo by Dick Tichenor

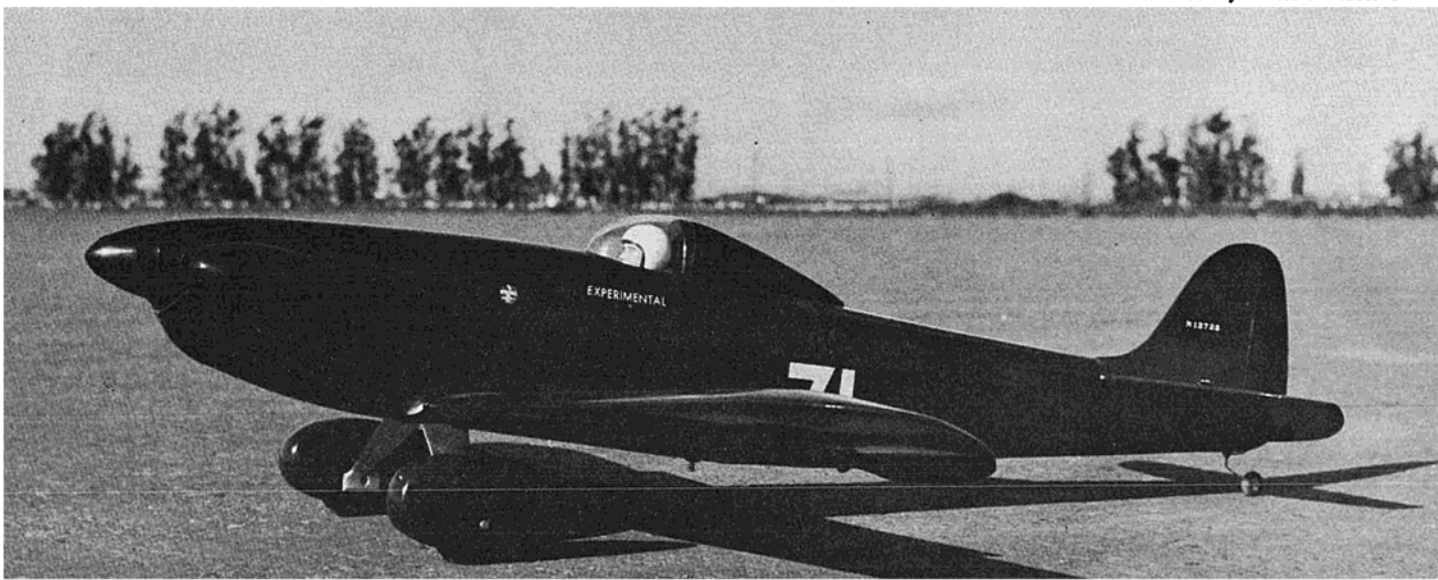

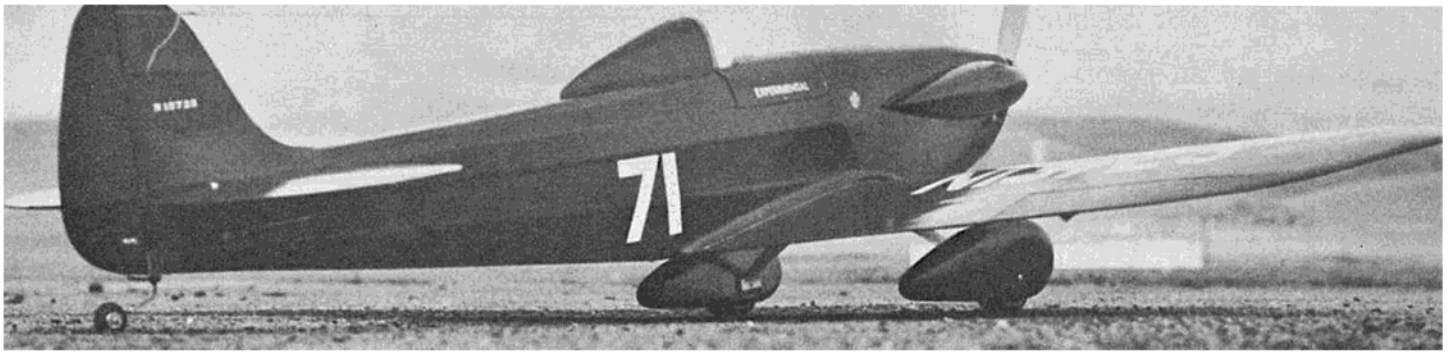

landing gear is in place, it holds the forward part of the wing in position.

I think by now you will have realized how easy this type of construction is, and it shouldn't have taken more than four hours to get this far with only a couple of dollars worth of wood. The rest of the fuselage is fairly simple to build and the drawings should be self-explanatory. The engine may be mounted either inverted or upright with any good radial mount. I, personally, prefer the inverted method simply for appearance and ease of construction. The portion of the fuselage forward of F1 can be built to suit the engine and mounting method used.

The stabilizer is constructed from $\frac{1}{4}$ " sheet, silked, elevators attached, and then glued in place on the fuselage. The vertical stabilizer may also be made from sheet stock, but I doubt if it will look as good as one that is built up.

The fuselage should now be covered — this can be accomplished with one piece of silk wrapped completely around the fuselage with the seam being joined together on the $\frac{3}{16}$ " square stringer on the bottom of the fuselage. Don't forget to use Scotch tape as shown to keep the silk from adhering to surfaces other than those intended.

Finally, the head rest and cheek blocks may be carved to shape, sanded, and glued in place.

Wing. The wing for the Denight Special utilizes a flat bottom section except for a $\frac{1}{8}$ " curve from the main spar to the point where the leading edge connects. Therefore, the easiest way to build this wing is to glue together three 4" wide sheets, cutting it to the overall wing outline. Lay out the rib and spar locations

on this outline, then build the wing on a completely flat surface. Put a $\frac{1}{8}$ " shim under the leading edge of the sheeting in order to allow for the airfoil shape.

After the ribs and spars are glued in place, install the bellcrank as shown. Ailerons can be carved out of a block and attached with sheet mylar strip hinges.

The leading edge is glued in place after the wing is completely sheeted. The wing is then joined together and notched out for the landing gear block. Take a little extra care at this point and make a good fit without any slop. Cover and finish the wing before fitting it to the fuselage so you can be assured of a good fit when the model is completed. When fitting the wing to the fuselage, a good tip to remember is to use a strip of sandpaper about $1\frac{1}{2}$ " wide, dragging it between the wing and the fuselage to remove any high spots.

To add the wing fillets to the fuselage, take a couple of scrap pieces of soft 20 gauge aluminum about 13" x

2" in size, wrapping the excess over the leading edge where the fuselage will fit on. Use masking tape to hold it in place while the fuselage is put on and outlined, allowing for a leather fillet. Cut on these scribe lines and fillet, then scribe the outline on the epoxy to the fuselage while holding it in place with the wing. Now add the leather fillet. This works out quite well and is really worth the effort. You get a perfect fit, and the assembly does not warp from applications of dope. It is also completely fuel proof.

That's about all there is to building the Denight Special. I don't feel that it is necessary to go into RC installation for there is ample room for almost any type of gear without special installation tricks.

The Denight Special has shown no undesirable flight characteristics, and has been flown on reeds as well as proportional. We think you'll like this model, and even more, the new Good-year event for RC.

See you at the races.

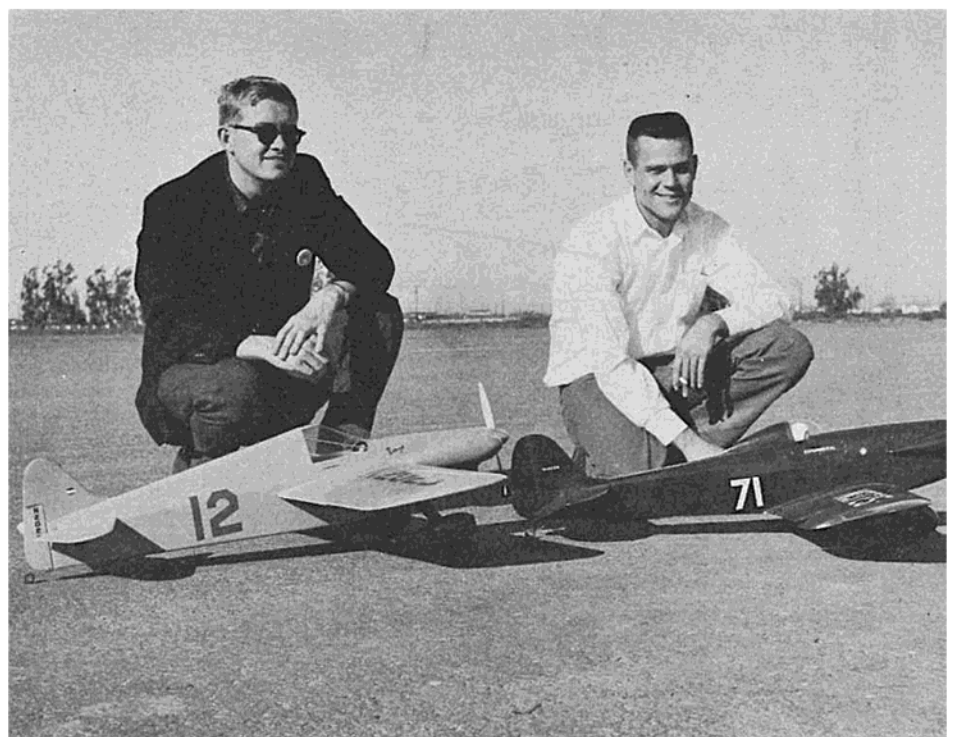

Right: The author with his Denight Special, shown with Jerry Nelson and the Bonzo.

Photo by Dick Tichenor

RIB MAKING TEMPLATE

RIBS 1 & 2 - 1/8" Balsa
3-11 - 3/32" Balsa

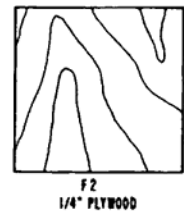
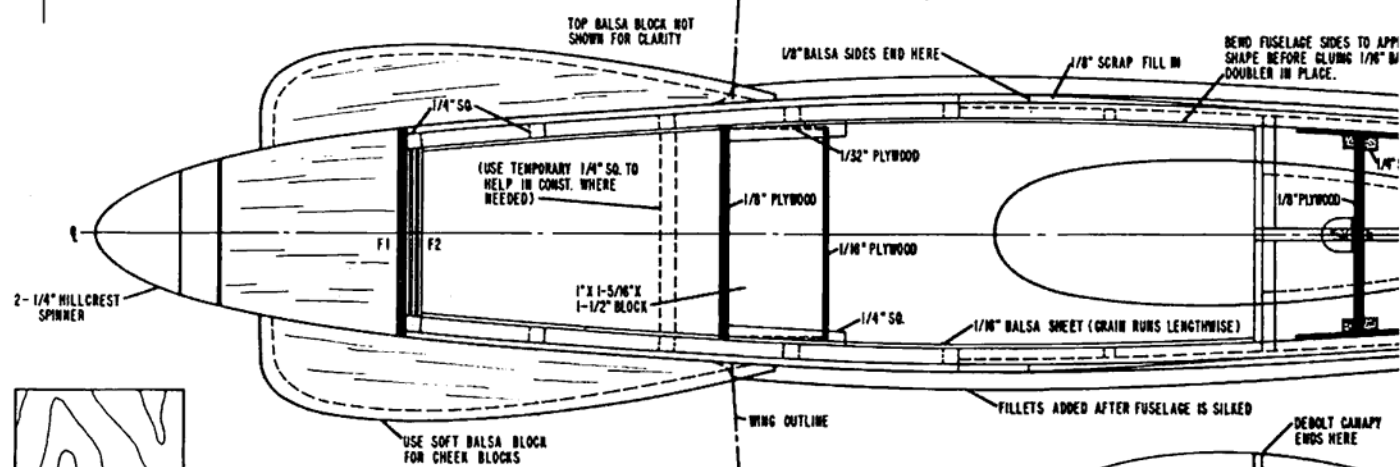
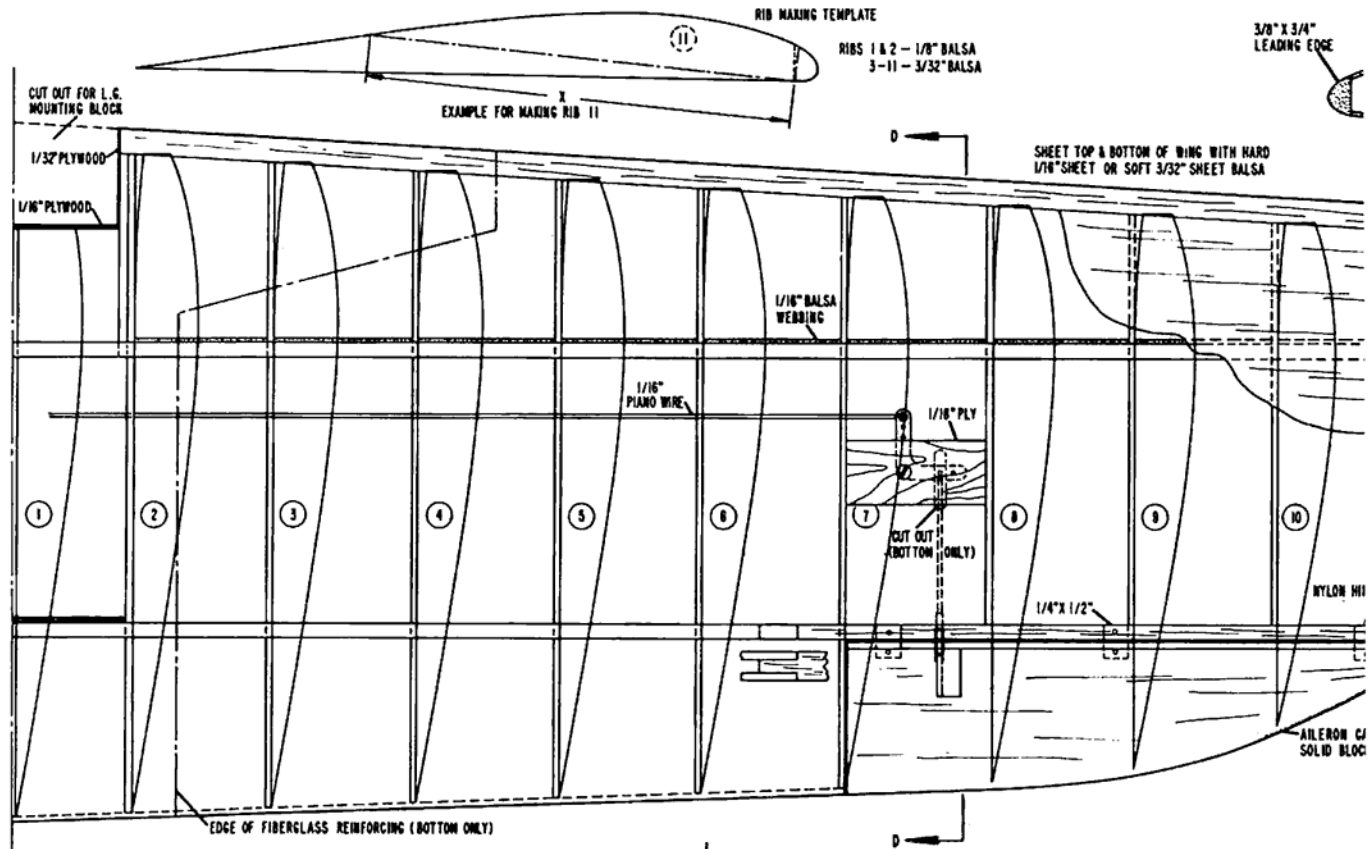

MOUNT ENGINE ON RADIAL MOUNT
3" RIGHT THRUST
2" DOWN THRUST
MAX. ENGINE SIZE .40

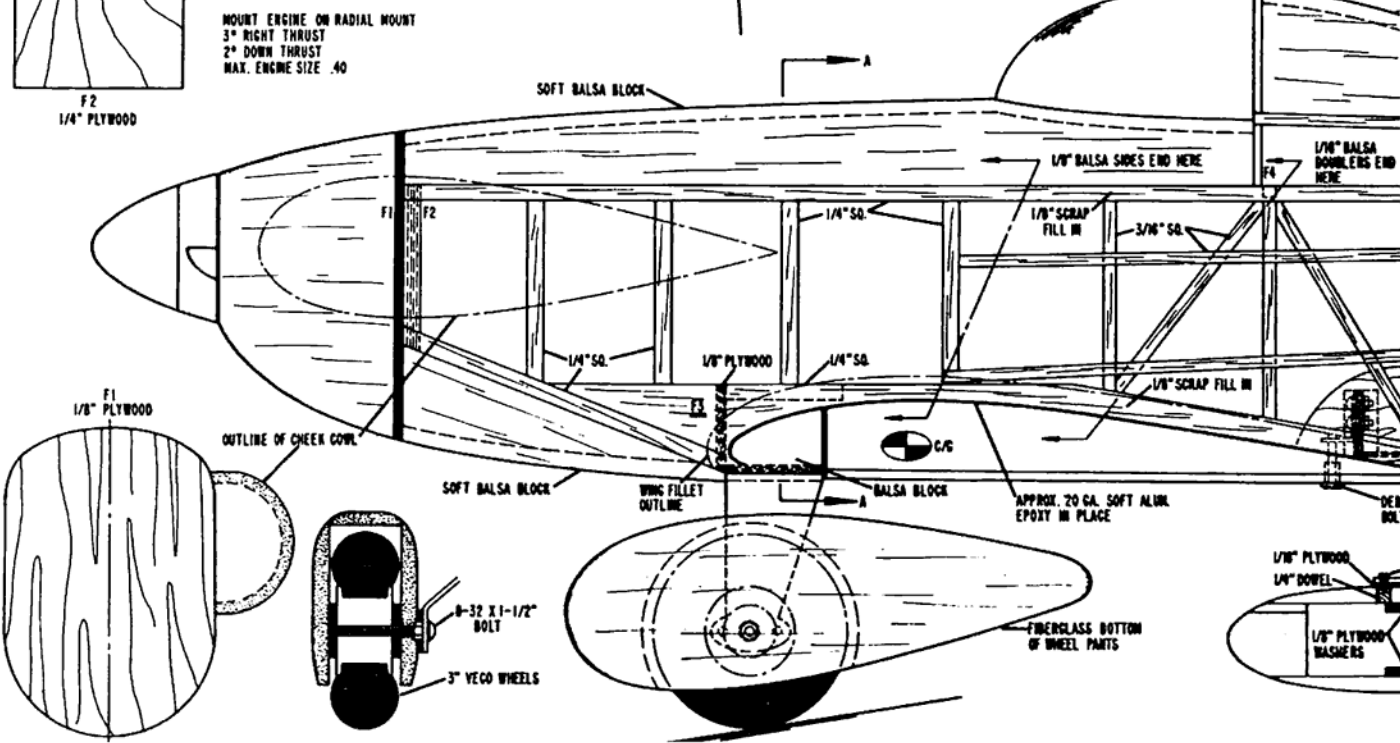

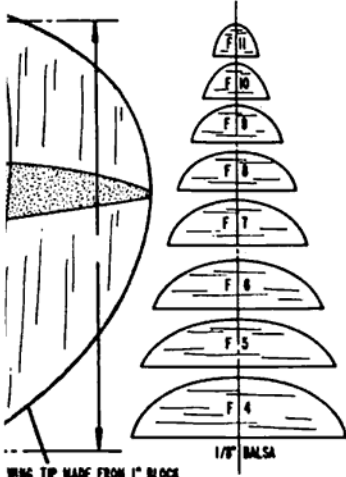
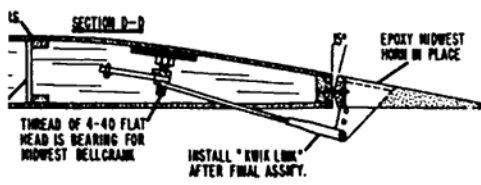

NOTE - SMALL CONTROL SURFACE MOVEMENT IS HIGHLY RECOMMENDED.

COVER ENTIRE MODEL WITH SILK

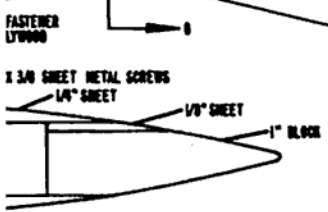
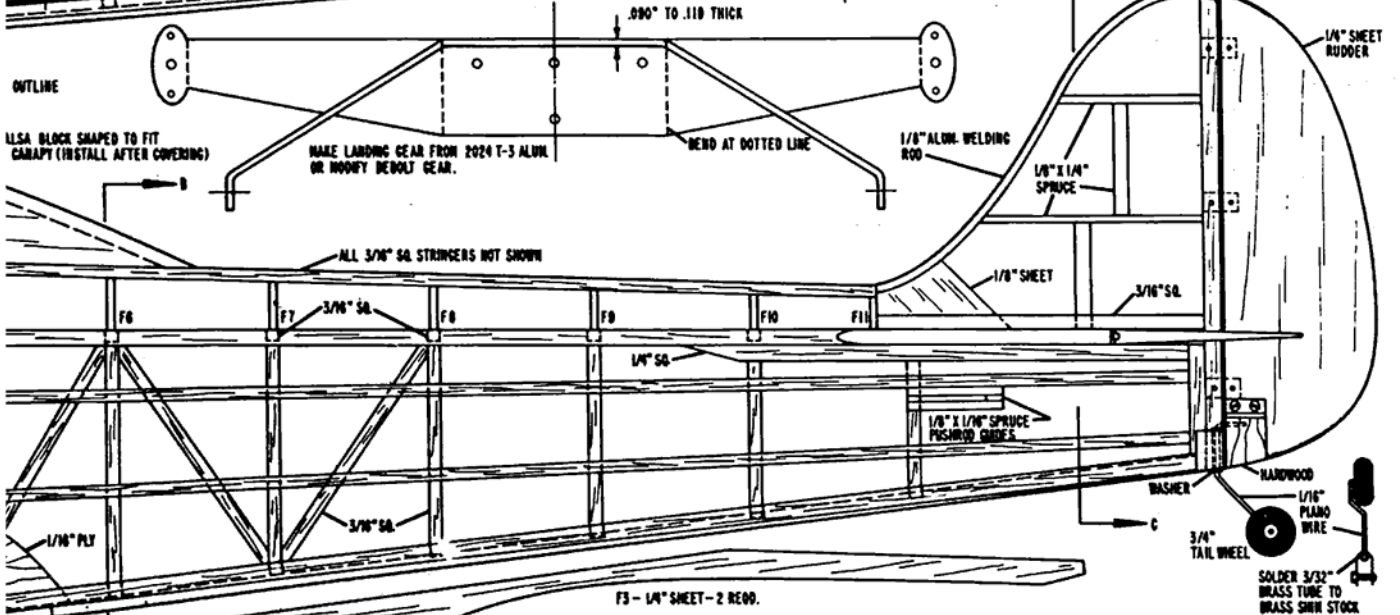
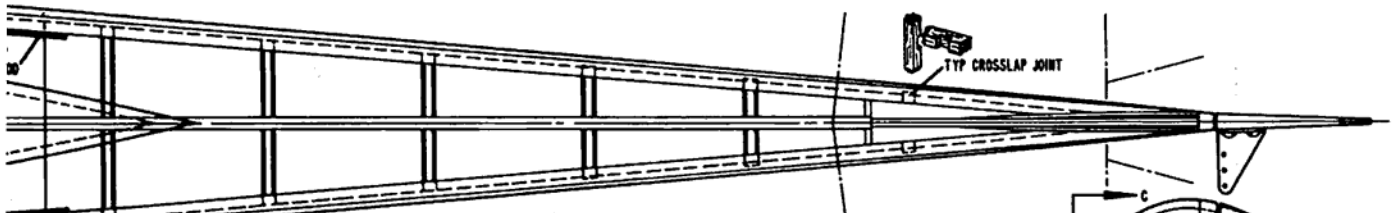
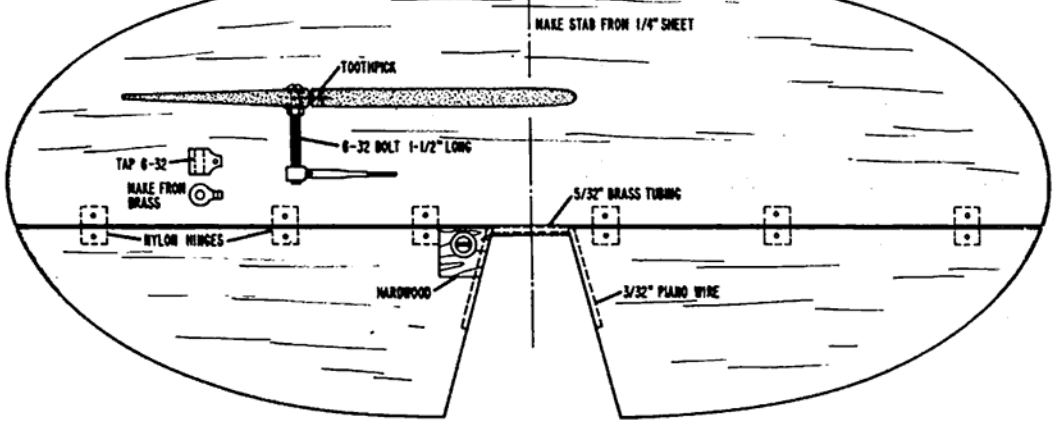
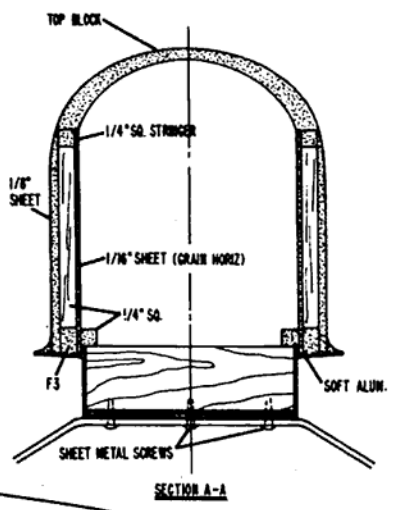
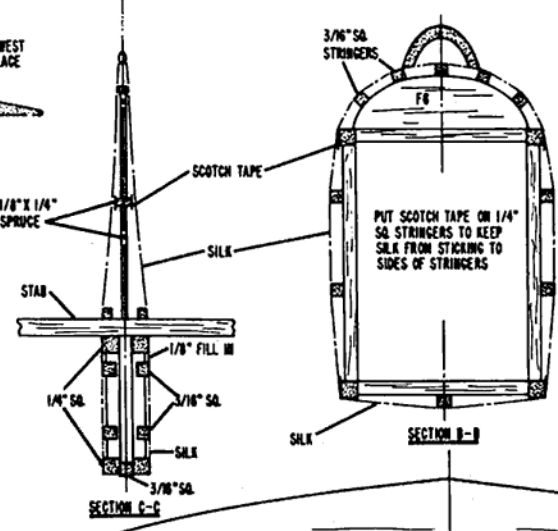

EQUIPMENT USED IN PROTOTYPE:
MHI-X 10 CHANNEL
BANNER SERVO'S
JOHNSON .36 RC

THIS MODEL IS NOT AN EXACT SCALE MODEL OF THE ORIGINAL DENIGHT SPECIAL, HOWEVER THE OUTLINES SHOWN ARE CLOSE TO TRUE SCALE. THE APPROX. SCALE OF THIS MODEL IS 2-5/8" PER FOOT.

THIS WAS DESIGNED TO CONFORM TO THE SCALE SECTION RULES OF THE NATIONAL INMATURE PYLON RACING ASSOCIATION.

SPAN 50" LENGTH 43" FLYING WEIGHT 3-1/4 LB. PLUS R/C EQUIPMENT.

R/C modeler DENIGHT SPECIAL

DESIGNED & DRAWN BY	JOE MARTIN	TRACED BY	DICK KIDD
---------------------	------------	-----------	-----------

ENGINE OBEDIENCE COURSE

By DUKE FOX

Like our canine simile, 98% of an obedience training program for a model engine depends upon the cooperation of the master. I am directing these comments primarily to the multi-channel flier who has a servo-operated motor control.

The first area I would like to discuss is the selection of the fuel mixture for your particular engine. This is more important than most people realize. Here is why: A motor that is properly set will drop RPM badly if there is insufficient nitro. The natural impulse, then, is to lean the adjustment, which moves the mixture into a range so that when the tank level drops, the motor will die in an over-lean condition. On the other hand, a fuel that has too much nitromethane will not maintain its full power when the tank is nearly empty.

This is the way I recommend you make a test: First, equip yourself with a fuel bottle and about two feet of fuel line. Connect the fuel line to the carburetor and rig the assembly so that you can raise and lower the fuel bottle with one hand and actuate the throttle with the other. This type of procedure will be used not only for testing fuel, but during the engine adjustment procedure.

To check your engine for insufficient nitro, start the engine, set the throttle in wide-open position, and raise the fuel bottle until the engine is running in a definite four-cycle. This should be done with the glow plug wire connected. Then remove the glow plug wire. If there is any drop in engine RPM when you remove the glow plug wire, you do not have sufficient nitro in your fuel.

To check for too much nitro, again with the throttle wide open, lower the fuel bottle until the motor is as lean as you can make it without losing RPM. If the motor will continue to run for a full minute without sagging, you do not have too much nitro. The idea, of course, is to select a fuel mix that will allow the engine to run at both rich and lean settings without power loss.

I suspect that most engine failures during high speed settings can be attributed to selection of fuel with too little nitromethane. For our Fox 59 R/C and our 15 R/C, I definitely recommend a fuel such as Missile Mist, which has about 24% nitro. Once you select a fuel, stay with it, don't vary the brand or mixture from flight to flight or week to week. It may be to your advantage to buy a mild fuel and spike it with a concentrate such as Blast.

It has been said that nitromethane has a bad effect on idling, and in a general way, this is true. We have found, however, that by properly balancing nitromethane and nitroethane, this effect can be reduced to a level where it can be handled in other ways.

It is my belief that once an R/C engine has been properly adjusted, troubles can arise only from fiddling with the needles. A modern R/C engine carburetor is a rather complex thing with many interrelated effects, and unless they're approached in proper sequence and in a logical manner, you can easily work yourself into a corner. It takes me about an hour to go through a carburetor adjustment procedure, but once this is done, you're set for hundreds of flights. So far as I can see, any normal weather and altitude variations have negligible effect on a properly set carburetor. Troubles do occur when the fuel mix is changed or brands are changed from flight to flight.

Now for the adjustment procedure I use in setting up a 59 R/C: First the engine is started with the fuel bottle connected externally as earlier described. With the fuel bottle level with the carburetor, the carburetor is set in the wide open position and the

fuel bottle lowered to a level simulating the bottom part of your tank when the model is climbing vertically. The high speed needle is then adjusted so the engine is running at a maximum power setting. To check, the bottle should be gradually raised, and when it is level with the carburetor, the motor should still be running in a two-cycle but slightly rich. The fuel bottle should continue to be raised until it is some six or seven inches above the carburetor, simulating the tank position when the model is in a vertical dive position. The motor should be in a definite four-cycle now, but should not show any tendency to slow down with continued running. If it slows with continual running, this signifies a plug cooling condition, which should be countered with a higher nitro fuel, different make of plug, or closer fuel tank position.

Once you get the engine running well in the wide open position, set the throttle in the 50% open position — that is, with the arm halfway between open and closed, and go through this same procedure. With our 59, the intermediate range will vary the least with fuel bottle position changes, and you should be able to find an adjustment that will cover the bottle-up and bottle-down position without breaking into a four-cycle.

Now, to work on the idle: Several explanations are readily in order here. First, in a slow speed, our 59, along with most other engines, idles in a four-cycle. The motor can die lean and still be four-cycling. You cannot reliably trust your ears. You should use the fuel bottle routine, raising or lowering the fuel bottle until the engine shows signs of dying, to determine lean and rich. Second, we have an interrelationship of glow plug cooling off and mixture change, and to separate these we keep the glow plug heater on during mixture adjustments. The exhaust valve should not be considered a speed control device, but rather it is a damper to prevent extraneous air circulating within the cylinder at low speed and unduly cooling the plug.

(Continued on Page 28)

Duke Fox is not only one of the world's leading manufacturers of model engines, but an old pro at virtually every form of model aviation. Having caught Duke in one of his rare literary moods, RCM is proud to present this article on taming the R/C engine.

Engine Obedience Course

(Continued from Page 27)

To proceed with the adjustments — remove exhaust valve and connect the glow plug wire. Work with the mixture and butterfly adjustments until you get the engine idling so that it will tolerate an equal bottle-up and bottle-down variation without dying. Once you have located the proper butterfly and mixture adjustment for idle, speed the idle up about 25%, then connect the exhaust valve. The exhaust valve relation should be so arranged that this will pull the engine back down to the originally desired speed, and should provide enough damper so that the glow plug heat can be removed. Too much exhaust damper makes the engine unduly sensitive to fuel level variations; too little exhaust damper will permit outside air to circulate the cylinder during the piston down position and will cause the engine to quit cold.

Now — we have the engine running properly at idle, at intermediate, and at high speed. What remains is to check and see that the transition from low to intermediate and the transition from intermediate to high is smooth. To check for lean spots, start the engine, lower the fuel level about six inches below carburetor, and slowly move the throttle through the full range, looking for any spots where the engine may want to die lean. If a lean spot occurs between low and intermediate, the solution is to apply a small chamfer to the intermediate jet. The throttle barrel has to be removed to accomplish this. Usually a .010 chamfer on the jet edge will cure a moderate lean spot. It really isn't important to have a chamfer all the way around. What we are trying to do is to move the fuel passage slightly toward the center so that it will open up a bit sooner. If you overdo it, there is no correction, except to fill the area with solder, dress it down, and start over, so be very cautious.

If there is a lean spot between intermediate and high, the solution is to remove metal from the throttle body notch on the forward side of the high speed jet notch so that as the barrel rotates, the high speed starts coming in sooner. When properly adjusted, you should be able to move the throttle completely through the range with the fuel bottle in the full-down (six inches below throttle

level), to six inches above the throttle level.

The above procedure, of course, applies to the Fox 59 R/C. Other make R/C motors each have their own type construction and require slightly different technique; however the general procedure applies to all engines. Veco and K&B type throttles which utilize a needle body in the middle of a rotating barrel reduce fuel flow at slower speeds by reducing suction to draw less fuel. This system can be made to work beautifully also, except that it will not tolerate any appreciable gravity flow at lower speeds. For this reason, the fuel bottle position in the airplane is critical, and should be so located, that when the airplane is in a normal gliding position, that the fuel level is not higher than the carburetor. Also, prolonged nose-down throttle-closed attitudes in the air must be avoided.

If your carburetor is of the barrel type and does not have an auxiliary air-breathe adjustment, idle mixture corrections can be made by filing a tiny notch in the upper or lower intersection of the rotating barrel. A notch in the upper portion of the barrel reduces fuel suction and results in a leaner mixture. Notching the lower portion of the barrel increases fuel suction and enriches the mixture. Alterations by filing should be done cautiously and only after repeated experiments with raising and lowering the bottle convince you that this needs to be done, as there is no recourse once you have filed the part.

To achieve that easy, confident, completely "master of the situation" pose, you should not neglect your homework. First, a glow plug can be checked with an ammeter. I like to have a small meter taped to my booster batteries in series with the plug. A shorted plug or burnt-out plug will immediately show up the second the clip is connected. There is no excuse except laziness for attempting to start a motor with a plug burnt-out, and never, never any excuse for going out on a contest flight line with a burnt-out plug.

Your model engine compartment should be kept clean. I use a paint brush about one inch wide and Stoddard solvent. The engine mounting screws, the cylinder head screws, and others should be checked to see that they are properly tight. Fuel line should be inspected for kinks or a worn area. The prop nut should be

checked to be sure it is tight. If you want to be really impressive, open the throttle, put about 5 drops of fuel in the exhaust port with the piston in the down position, and then bring the piston into the up position, and close the throttle. When you arrive at the field and your model is ready to start, this pre-prime will often as not give you a one-flip start from cold. Very impressive to spectators!

Do not try to idle a cold motor, but when the motor is first started, run it at partial or full throttle for ten or 15 seconds in order to warm the engine before pulling back to idle. A cold crankcase will not vaporize fuel properly, and the engine will die in an over-lean condition. Another thing that often fools a model builder is partially congealed fuel in the fuel line or in the carburetor body. When you first start the cold motor, this congealed fuel in the jets and passages will cause it to act like it is over-lean. If you start moving the needle valve, you are just messing up the detail. Better to let the motor run for a few seconds so the fresh fuel can come through and wash the passages clean, even if you have to help the mixture for a few seconds by using your finger to choke the intake.

The nature of a model airplane engine is to deliver power in intermittent impulses. The larger the engine, the more power, the more severe impulses, and the more apparent vibration. The actual energy transmitted into your model is proportional to the force times the amplitude. The force you can't do much about, but the amplitude can be reduced by making a good rigid motor mount and front end structure. The idea of shock mounting a four or six-cylinder engine is good, but in a one-cylinder model airplane engine, you want the most rigid mount possible. The most common structural weak point is failure to tie the two motor mounts together well at the firewall. You cannot expect two beam motor mounts to not flex with relation to each other if they are only tied together with a piece of 1/8" plywood and a few balsa strips.

You have, from time to time, heard about someone who flipped his engine a few times, took off with a quick burp, then stopped in about two or three seconds time after time. This is caused by routing the fuel line up and

(Continued on Page 41)

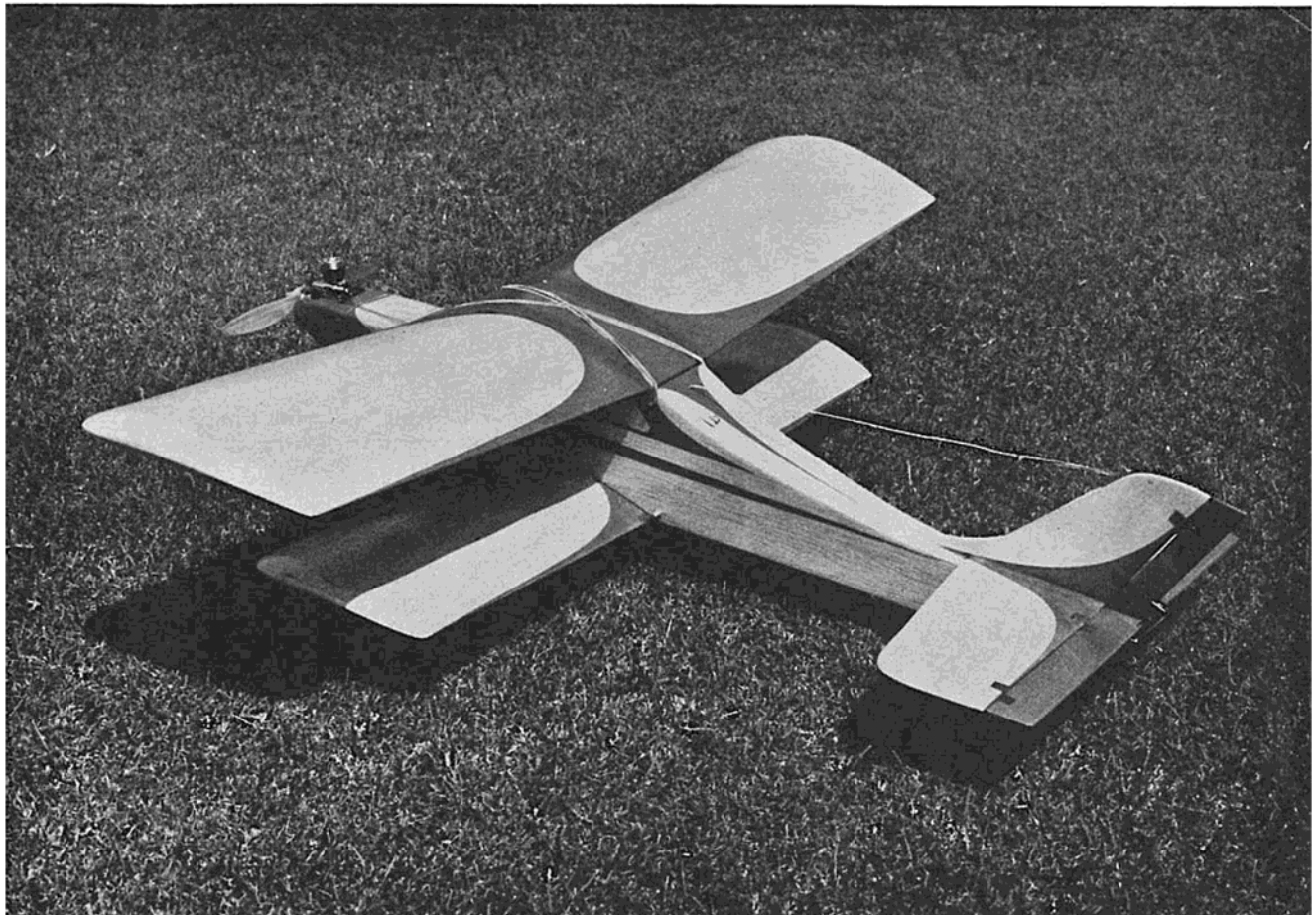

The Maestro's latest single channel sportster is characterized by a flair for appearance and performance that promises to outdo even its renowned predecessors.

THE SCHOOLGIRL

By
KEN WILLARD

For the last couple of months I've been promising to publish the plans for a new sport biplane, only to keep postponing the deal because you fellows have been coming up with some timely items. Since I showed you the teaser picture in the January issue, I'd better get with it and put out the plans, so here they are.

The model is called the Schoolgirl — for obvious reasons. One short look at the plans and you'll note the family resemblance to the Schoolboy and the Schoolmaster. Actually, the Schoolgirl was designed to fill the gap between the Schoolboy and the Schoolmaster, with respect to the power range. The Schoolgirl uses .020 or .049 power and, like the others, is gentle with the lower power, and really zippy with the larger engine. In fact, with .020 power you'll have

to use the Cox TD.020 with the special "high thrust" prop that's been designed for it. Otherwise, the model is sluggish. However, with that special prop, the Schoolgirl is a solid performer on .020 power, and will do excellent loops using the pickup elevator.

And why a biplane? Well, just because I love 'em, and it's been my experience that thousands of other modelers do, too. But if you're too lazy to build the lower wing, then leave it out and fly the model as a monoplane — it does a fine job. But to me it's a lot prettier as a biplane, and the lower speed makes it much more realistic.

So let's get on with the building and flying instructions. Actually, the building is simple and standard — just a few hints to go along with the

plans are all you'll need.

Wings

Both wings are what I would call "standard sheet balsa", as developed by Top Flite for their compact kits. Of course, they use a shaped leading edge, to the right contour. It's a chore, but it doesn't take too long.

For those of you who prefer built up wings, they fly just as well—They're just a little more work. If you want to do it though, I'd suggest a single 3/16" inch square spar along the top and exactly at the peak of the top camber. Cut out the ribs just as though you were using the sheet covering, then sheet the leading edge back to the spar on top and about one inch back on the bottom of both wings. Make the trailing edge either from trailing edge stock, or two pieces of 1/16 by 3/4" wide sheet at the top

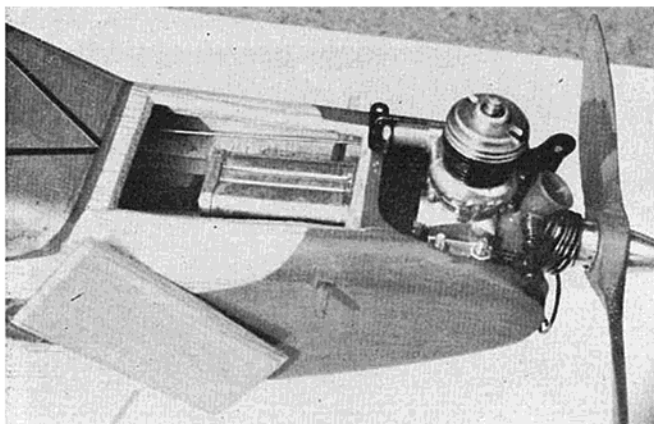

Engine control pushrod goes through firewall, then doubles back to loop through throttle arm. Note slant of hatch sides. Perfect #19 tank used.

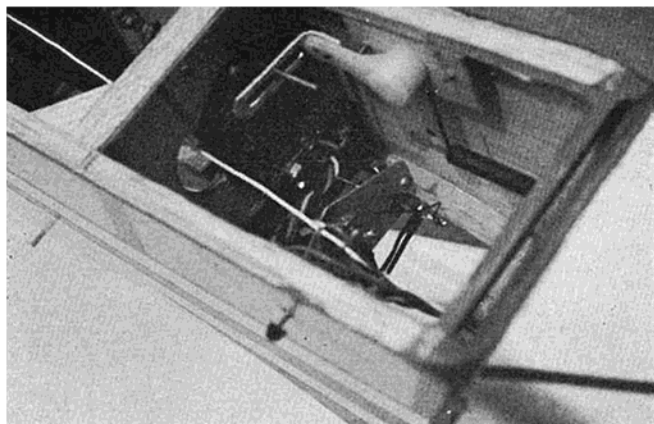

View of motor control, bellcrank, and sleeves adjustment tube, on engine control pushrod. Latter allows infinite adjustments.

and bottom of the trailing edge of the ribs. Then cap strip the ribs from the spar back to the trailing edge and from the bottom sheeting to the trailing edge on the bottom. If you make the cap strips about $\frac{1}{2}$ inch wide you can use the same rib spacing as the all sheet wing.

Reminder: Don't forget to angle the ribs slightly at the center section joints so they'll glue together at the right dihedral. This butt glue joint, when reinforced by the celastic strip as shown, makes a very strong center section. If you can't get celastic locally, then complain to your dealer, because it's great stuff for strengthening joints, repairing breaks, etc. However, if he doesn't have any, then you can use linen, cotton, or nylon cloth — the weight that is used in bedsheets would be about right.

Tail Surfaces

Make these from medium grade $\frac{3}{32}$ " sheet. Don't use the rock hard stuff. You don't need that much strength, and it only adds unnecessary weight to the tail.

The elevator and rudder hinges are

cut from linen or cotton cloth. You could also use the hinge material which the hobby shops sell with the "pinked" edges. Now here's an important suggestion. Don't attach the hinges until after you've finished dopping the surfaces, and when you do glue them in place, avoid getting glue on the cloth that goes through the hinge line. If you do, it'll get stiff and brittle, will crack and break, and won't work well. When the rudder and elevators are attached, they should flop freely, restrained only by the torque rod arms going through the retaining pins.

Landing Gear

Because it's simple, functional, and sufficiently strong, I like to use the bent wire gear, attached with shock absorbing rubber bands. However, it's a matter of choice, and the bent dural gear, which is so common, will serve equally as well. Just add another dowel to anchor the back to or else replace the $\frac{1}{8}$ " dowel for the lower wing with a $\frac{3}{16}$ " dowel that will serve a dual purpose.

Looking down on receiver, Otarion switch, (no longer made) and Babcock escapements.

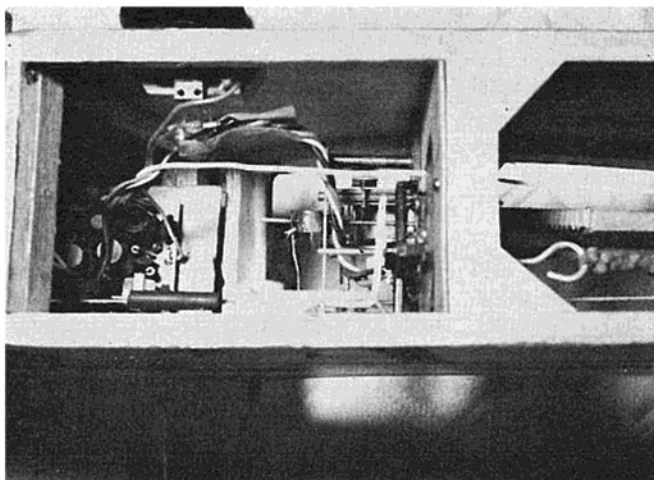

Rudder and elevator torque rod arms.

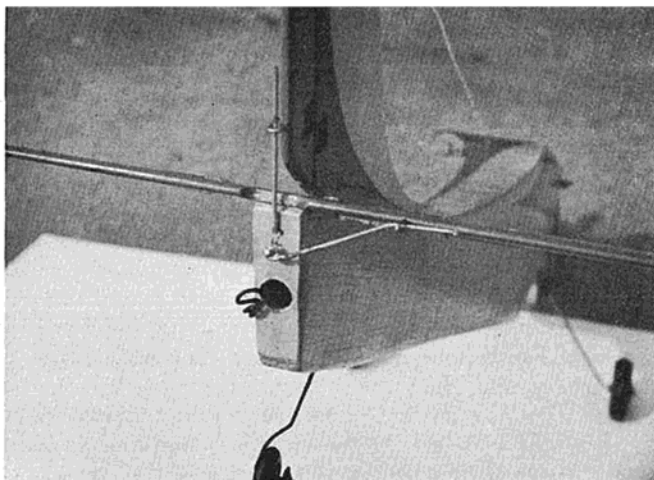

Fuselage

As always, this is the most complex part of the structure, therefore, I usually leave it to the last. Then the completed wings and tail surfaces hang around the shop, silently accusing me of being lazy, until I give them a body to which to belong.

Even so, the Schoolgirl fuselage is quite simple in comparison to some designs. Yet the use of gentle curves, with rounded corners at the windshield and forward structure, results in very pleasing lines.

To assemble the fuselage, first cut out the sides and glue the doublers and braces in place. Next, lay one side flat on your worktable and glue the cross braces in place at the leading edge and trailing edge of the wing locations. Make sure they're at right angles to the side on the worktable and quickly glue the other side to the cross braces. Prop the cross braces and supported side in place until dry, then add the cross bracing at the escapement bulkhead. This cross bracing should be of the "rock hard"

(Continued on Page 33)

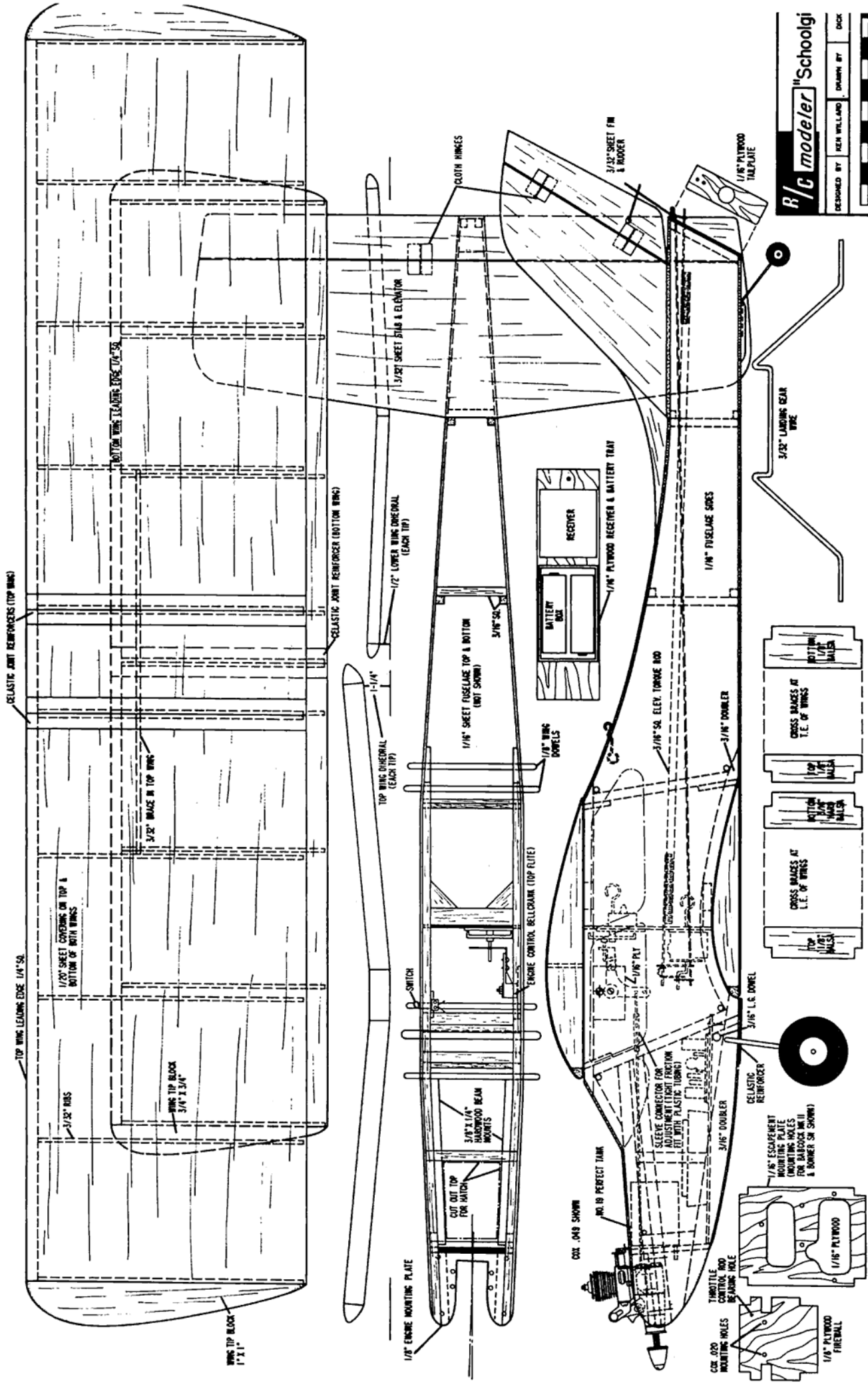

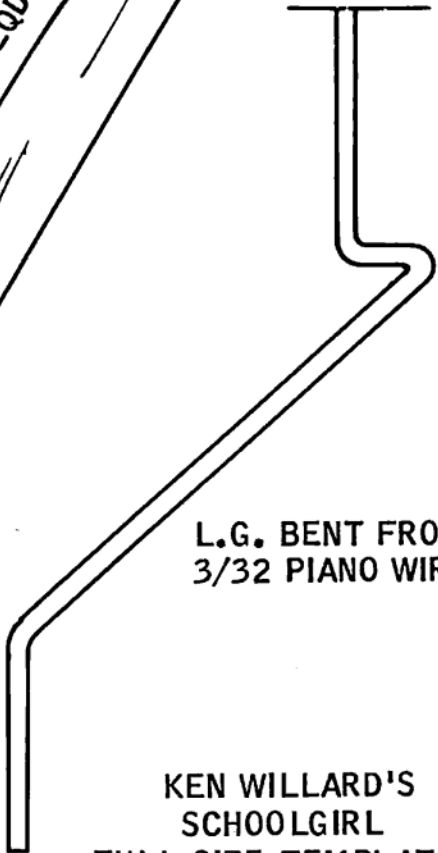
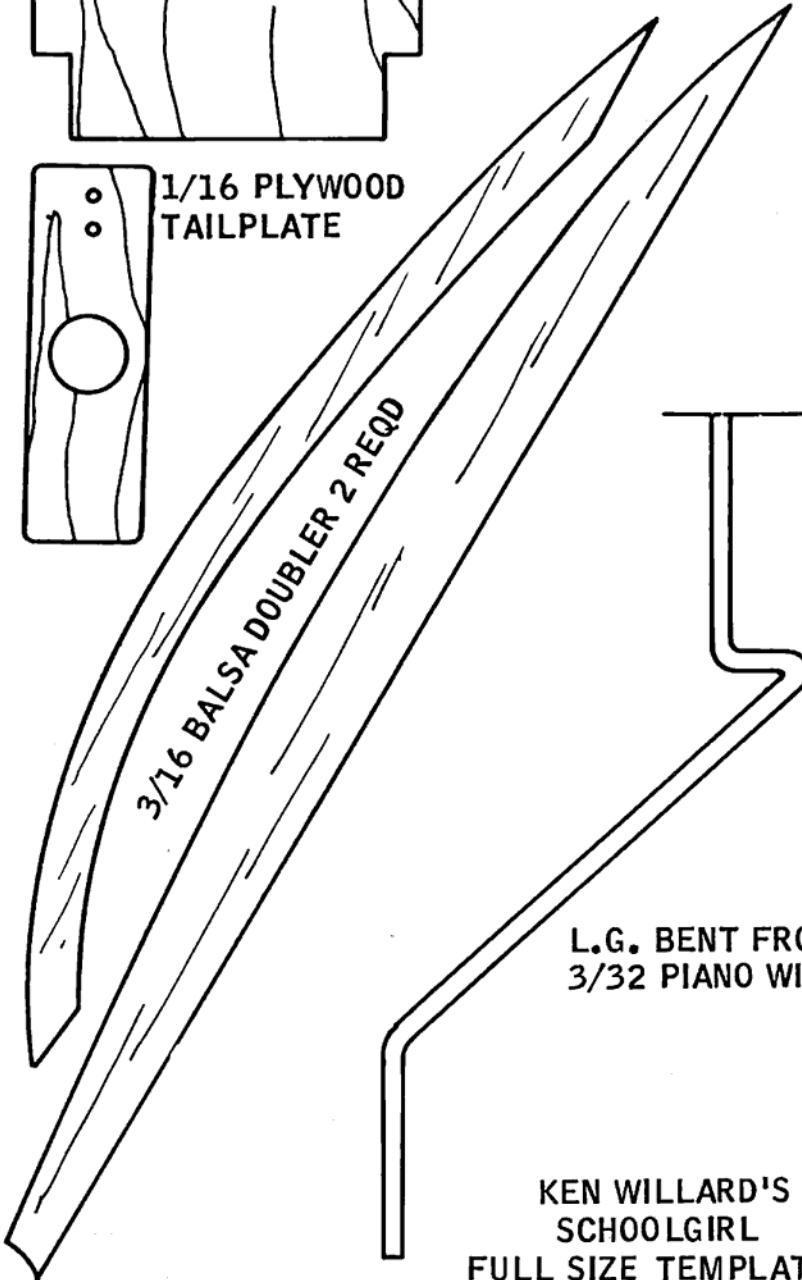
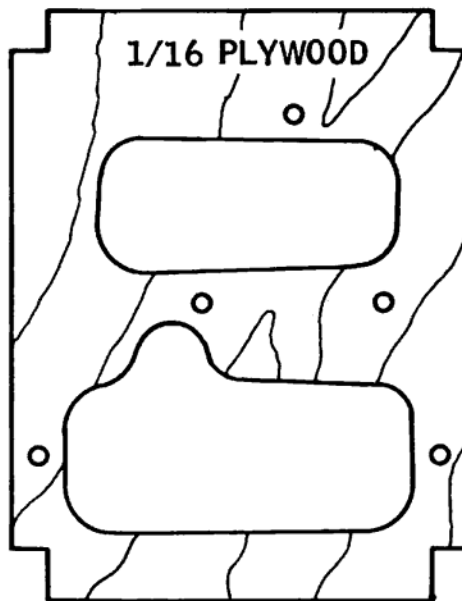
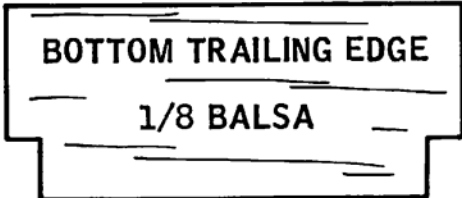
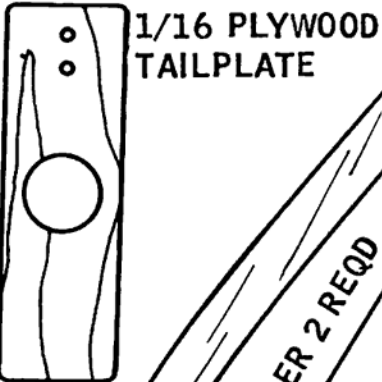
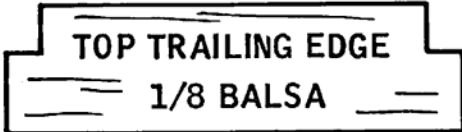
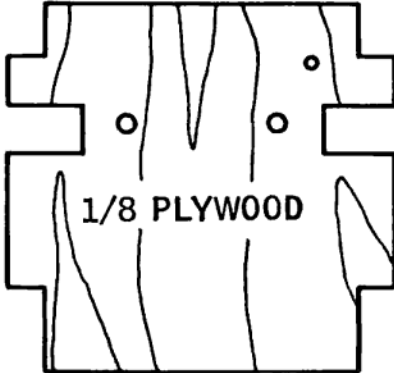
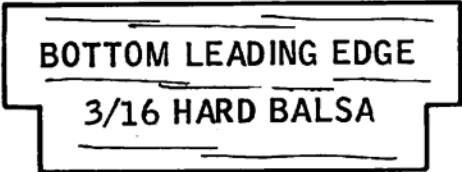
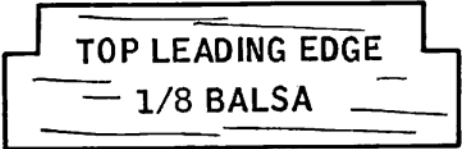
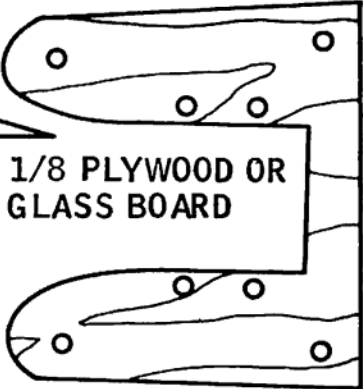
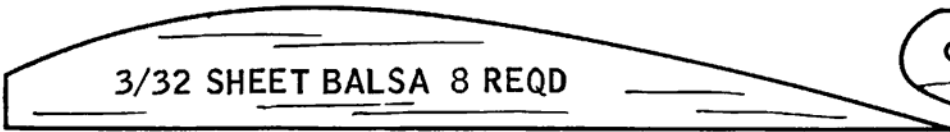
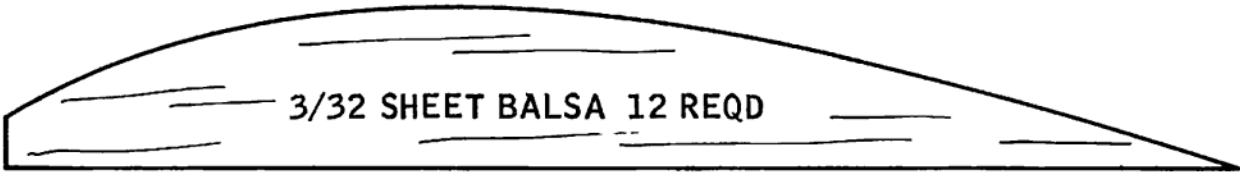

KEN WILLARD'S
SCHOOLGIRL
FULL SIZE TEMPLATES

Schoolgirl

(Continued from Page 30)

balsa variety, since the escapement bulkhead is attached to it with screws for easy access and removal.

After you get the cabin area structure firmly glued together, the nose can be pinched together to fit the firewall in place, then the tail pulled together and the tailplate glued on. When you do these two operations, be careful to sight along the centerline and make sure the two sides are pulled in equally. Otherwise, you'll wind up with a longitudinal curve in the fuselage centerline — and that can cause some real problems in the flying adjustments.

Now, just add the other crossbraces, the wing, and landing gear dowels, and you're ready to cover the top and bottom. Before you do that, though, I strongly recommend that you fit the removable escapement bulkhead in place and check the fit and operation of the torque rods. It'll be pretty close quarters, and you'd better make sure that all clearances are good before you close the fuselage. Note that the elevator torque rod is 3/16" balsa with wire ends, and the rudder torque rod is all one wire. This is to provide the clearance where they cross at the back.

After the top and bottom are on, you can shape the windshield corners and the fuselage corners forward of the wings into the slightly rounded contours which show in the photos. After the first coat of dope, add the elastic reinforcement to the bottom of the fuselage where the landing gear fits, or alternatively, you can dope that area locally before applying the elastic. Again, if you don't have elastic, then glue a piece of 1/16" x 3/4" plywood across the bottom so the landing gear wire is held against the plywood.

The engine installation shown on the plans for the Cox Medallion .049 with throttle control will probably give you a few moments of trouble. The engine bearing plate bolts to the engine bearers, and the quarters are a little cramped. I suppose I could have left the nose a little wider, but I happen to like the sleek, tapered look, and figure it's worth the little extra effort required in fitting the bolts in place.

Note the downthrust and right thrust which is automatically provided by the placement of the engine bearers and the cutout in the engine

bearing plate. You may find it necessary to add a washer under the rear mounting holes of the engine for a slightly increased downthrust angle if your flight tests show the plane having a tendency to climb too much under full power. We'll talk more about that later on.

The system which I have shown for engine control, using the Bonner SN, a Top Flite bellcrank, and a pushrod, has proven to be very reliable. For easy adjustment of the pushrod, I've made it two inches longer than the required length, then cut it just forward of the bellcrank. At the break, I've inserted the two ends inside a small diameter plastic tube about one inch long. Thus the two ends, overlapping about one inch, are held together in friction fit inside the tube. They can be, however, slid back and forth as needed for adjustment of the throttle linkage.

The receiver tray which holds the battery box and receiver as a unit, slides into the fuselage through the top opening. As it is inserted, the batteries fit underneath the fuel tank, and the forward end of the tray butts up against the firewall. Then the whole assembly is held in place with a small wood screw that goes into the cross brace.

Finishing

Whether you use dope or Hobby-poxy is a matter of choice; sanding, important first step, however, is not. Unless you have the wood sanded to a very smooth surface, neither dope nor Hobbypoxy can overcome a rough base.

Rounding the corners of the fuselage forward of the wings and landing gear can be done either by using a single edge razor blade — or Xacto knife, or by using rough sandpaper until the approximate curve is obtained. Then fine sandpaper is used to get a smooth finish.

The prototype was finished in butyrate dope. Four coats of clear, slightly thinned dope, with light sanding between coats, yielded a nice gloss to the natural wood finish. The red stripping was applied using masking tape; after it was located properly on the wood surfaces, it was sealed with clear dope before the red dope was applied. This prevents the red dope from seeping under the tape and spoiling the line.

After the fuselage is doped and finished, the access hatch above the fuel tank can be cut out. Cut the balsa on a slant, so the hatch will rest in

place and not fall through.

When you're ready to fly, the hatch can then be spot-glued in place, or held on by a strip of tape or a rubber band.

The fuel tank — a Perfect No. 19 — is held in place by the three point suspension provided by the filler tube extensions through the sides, and the fuel line nozzle at the bottom of the tank which protrudes through a hole in the firewall.

Flying

Out of respect for the well founded observations of my friend, Tom Stence, whom you read in the January column, I'd better give some instructions on adjusting and flying the Schoolgirl, and not brush the subject off with "It's been covered so often before." So here are a few things to do before launching the model on the maiden flight.

First, is the preflight checkout. With apologies to Tom, I have to say that in the February, 1964 issue of Radio Control Modeler I went into considerable detail on how to check your model for balance and for possible warps in the surfaces. True, the discussion was slanted to the Virus beginner's model, but the basic requirements are the same for all models. I'll review them briefly.

To check the center of gravity location, pick up the Schoolgirl by the top wingtips, with your fingers in line with the desired location of the C.G. as shown on the plans. The model should hang level. If it doesn't then move the batteries and receiver forward or back as required on the receiver tray. (The battery box and the receiver are held in place with rubber bands around the tray, so this is easy.) In this regard, it's a good idea to check the location of the batteries after any hard landing, just in case they jar loose and slide forward.

After checking the C.G., check all surfaces for warps. You're not likely to have any in the wings, since they are built on a flat surface and once they are finished they're practically the same as a box spar. This may not be the case if you make built up wings, since the covering sometimes can pull the wing slightly out of shape. Sight along the bottom surface of the wings and if the bottom of the tip rib isn't parallel with the center section rib, you'll have to warp the wing back into line. Heat the wing over the kitchen range until the

covering becomes pliable, then twist the wing while you hold it in place. While you're heating the wing, keep running your hand under it to prevent it from getting too hot.

Next, check the tail surfaces to be sure they're not twisted. If they are, you can realign them by the heat method described.

So, your model is balanced and checked for alignment. Next check the operation of the controls. The tail control surfaces should flop easily in following the torque rod arms. Particular attention should be paid to the elevator; make sure it returns to neutral from the kickup position. If your hinges are stiff and it doesn't drop easily back, then fix it — or you'll have to repair the whole airplane later! All models are very sensitive to elevator trim.

If you are using engine control, the Bonner SN hook up to the bellcrank must follow freely without binding, and up in the nose the exhaust baffle should slide freely back and forth. This may not be the case if the engine is cold and the baffle is a little sticky, but as soon as you run the engine briefly the exhaust will free up. In addition, you'll have to use very pliable fuel line, since the throttle system requires that the fuel line twist slightly.

So, the airplane is now balanced, the controls work, the surfaces are true, and you're ready to fly. Wait a minute! Did you check out your transmitter and receiver batteries? And did you check the tuning? You did? Okay. Let's fly it.

Fire up the engine and check out the controls with the engine running to be sure that vibration doesn't affect the controls. Check the quick blip, and incidentally, check the speed with which you can get left rudder (two pulses and hold) without getting an unexpected engine speed control because you pressed and released too fast in going from the first pulse to the second. That's one of the little hazards of quick blip.

Think we should try a hand glide? You can if you want to, but if you've done all the things described above, I doubt if it will prove anything (unless you've done something wrong.) But if you have a nice field of soft turf, and there's a slight breeze of about four to six miles per hour, you can glide it a couple of times and check the elevator trim and C.G. location.

Now for the first flight. If you have a friend that can give you a good hand launch, level and at the right flying speed, use him. If not, then try a takeoff (make sure the wheels spin freely.) Or if you're an old hand at it, you can launch the model in one hand with the transmitter in the other, though sometimes this gets troublesome if the model happens to slip or get caught by a gust before you can get your finger on the button.

About the only thing I can think of for you to watch for with the Schoolgirl is that it has the normal tendency of all bipes to lay over in a turn — and stay there. This is no problem unless you have a slight nose-down tendency, then the turn will develop into a spiral dive. Otherwise, the biplane will hold a turn and maintain altitude until you pull it out into straight flight.

Earlier, I mentioned that you might have to add some downthrust. This depends on the final balance of the model and also depends on whether you want a floating type glide or a fast one for flying into the wind.

I can't think of any real tricks in flying the Schoolgirl, except the same ones that apply to all models; for instance pulling the model out of a stall by turning it into a climbing turn with rudder. Of course, if you haven't lined up the surfaces carefully, or the C.G. location is off, a lot of tricks might be necessary, but in the sage words of Tom the philosopher, you'll make out all right as long as the "number of trials exceeds the number of errors by one . . .



By
DOUG SPRENG

The Proportional CONTROVERSY: *ANALOG* vs *DIGITAL*
Two Points of View

ANALOG VERSUS DIGITAL

What is analog proportional? Is there a true digital system? Which is best? The author, a top proportional flier and former Nat's champion, presents a penetrating analysis of this current controversy.

The purpose of this article is to present to the prospective buyer the relative merits of the two major types of feedback proportional systems — digital and analog. I will attempt to catalogue the various characteristics of the two types of systems, both good and bad, so that the buyer may make his choice based on fact rather than opinion. This article will deal strictly with feedback systems only — not systems based on T.T.P.W. concept where servo neutral return is effected by a spring or rubber band. Since the major differences are in the encoding, decoding, and servo amplifiers, I will not go into the RF link other than to point out the methods of transmitter modulation.

First of all, here is a short description of the two systems. Since analog came first, we will start with it.

Analog Proportional Systems

There are two major types of analog systems. One type uses four different tones which are multiplexed sequentially at the transmitter. The surface position information is derived from a pot mounted to a stick assembly. This produces a D.C. voltage, or a resistance, which varies with stick position. This voltage, or resistance, is used to vary the frequency of the tones. In the receiver, the tones are fed to four discriminators which develop an output voltage which is proportional to the frequency deviation of the tones. The derived voltage is then fed to a feedback servo consisting of a direct current amplifier, a motor, a feedback pot, a summing junction (which compares the input voltage to the feedback pot voltage), plus suitable gearing. If there

is a difference in magnitude between the input voltage and the feedback voltage, the resultant error signal is fed to the D.C. amplifier which drives the motor in such a way as to make the feedback voltage equal to the input voltage.

The other major system uses the same type of servo but the information

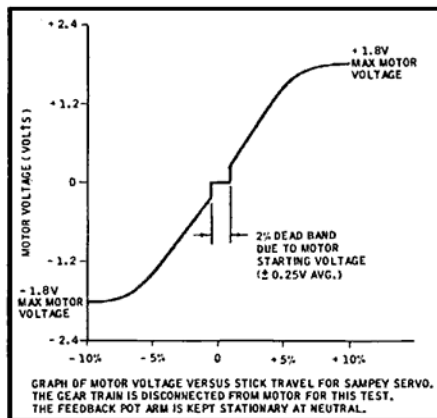
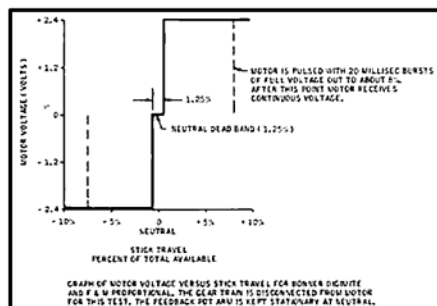

is transmitted in a different manner. It uses only two frequency modulated tones, transmitted sequentially. The other two channels are derived from the "on" time ratio of the two tones

and the repetition rate of these tones. There are only two discriminators in this receiver. The outputs of the discriminators drive servos as before, but in this case, the outputs also drive rate and symmetry detectors whose outputs are D.C. voltages that vary with stick position. These voltages are fed to the other servos which operate in the same manner as the servos driven by the discriminator.

Digital Proportional Systems

The main difference between analog and digital systems lies in the servo and the way it acts. But first, let me say that there exists no true digital system. The word "digital," as used, means that digital techniques are used in circuit design and system operation. For instance, the servo amplifier delivers either full or no voltage to the motor — there is no partial voltage as exists with analog systems. Another major difference exists in the way the information is used by the servo. In the analog system the pulse width or rate is first converted to a varying D.C. voltage and fed to the servo, whereas in a digital system, the pulse is left as is and compared directly with a reference pulse generated within the servo. The difference in the width of the pulses is the error signal, and the motor is then turned on and the reference pulse width is altered by the feedback pot in such a manner as to make it match the incoming pulse.

Now, in a true digital servo system a digital number is sent to the servo. Instead of a feedback pot the servo motor would drive an encoder wheel. Instead of a D.C. motor, the servo would contain a stepper motor. A digital number is comprised of a whole series of pulses or "bits." In the true digital system there can be as many as 19 "bits." The more "bits" there are, the more accurate the positioning would be. It would take 7 "bits" to make a system that would respond to an accuracy of 1%.

The information, as generated in a model aircraft digital system, is pulse duration modulation (PDM). This is

Author's note: No attempt has been made to present data on all of the proportional systems. Two digital and two analog systems were selected for use as examples. The data included on each was supplied by the manufacturer and include test results requested by the author. Orbit Electronics was unable to supply the requested information due to the press of business.

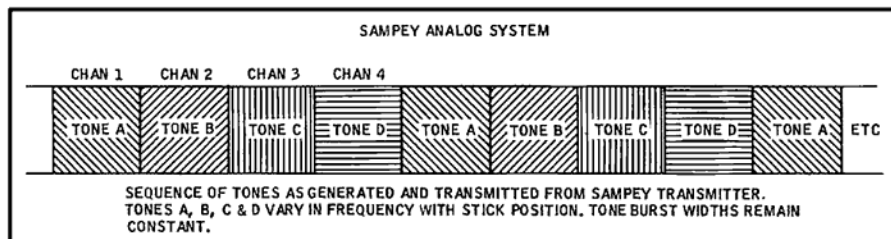

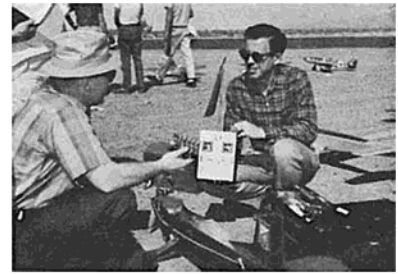
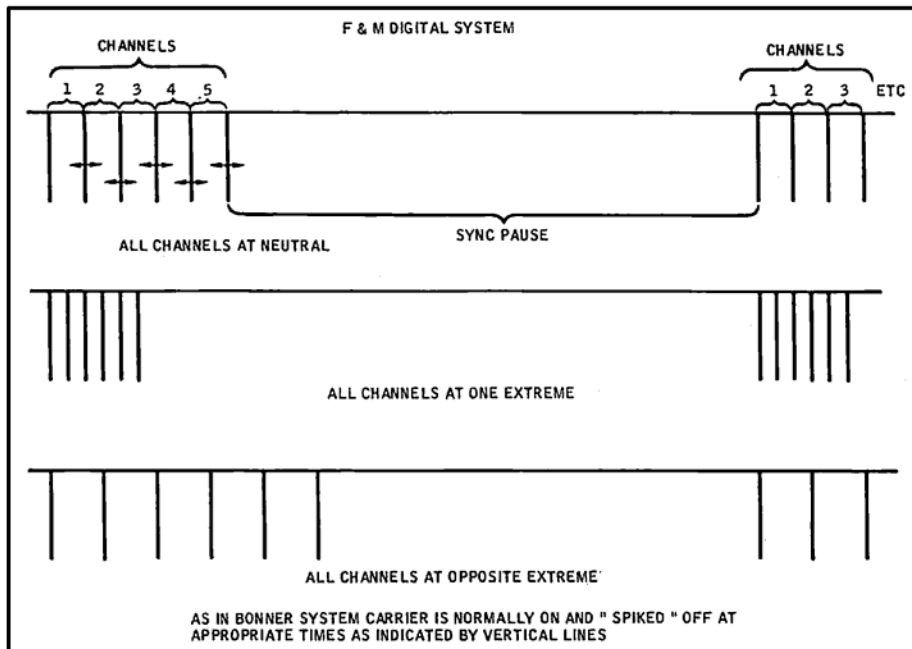
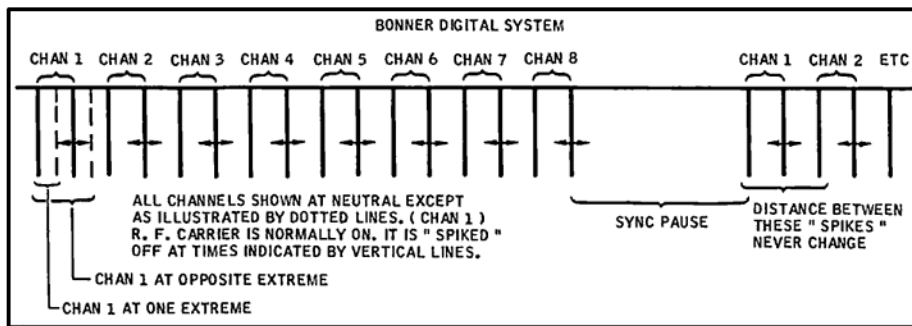

DOUG SPRENG, 32, began modeling in 1948 in the control line field, seemingly always to end up second in major contests to Bob Palmer. Doug started his R/C career with a Berkeley 'Brigadier' RC-38 and Aerotrol receiver, and went on to win his first contest in the rudder only event at the LARKS Open at Bakersfield, Calif. in 1957 — the latter strictly an accident, since Spreng only wanted to fly Don Mathes' "Mambo", and had to enter the contest in order to fly! The following year, he returned to Bakersfield to win his first Class III event with the Mathes designed 'Gambler,' the first of many contest wins in this event that included first place at both the 1960 and 1961 Nationals. In 1960, Doug designed the famous 'Stormer.' Currently, Doug is an electronics engineer at the world famous Cal Tech Jet Propulsion Laboratory, working on the Surveyor Program designed to analyze the crystallographic structure of the moon's surface prior to the first manned landing. A long time friend of RCM Technical Editor Don Mathes, Spreng was a co-designer of the early Digicon proportional system.

then converted to pulse position modulation (PPM) for transmission to the receiver. After detection by the receiver it is then reconverted to PDM, then fed to the decoder which separates each pulse and feeds it to the proper servo. Both PDM and PPM are considered digital techniques by the electronics industry. The method of generating the Pulse Duration Modulated information is called an Analog to Digital conversion. There is such a

conversion in the transmitter, where a potentiometer connected to the stick assembly generates a D.C. voltage whose duration (or width) modulates a standard pulse. The same process takes place in the servo amplifier. The feedback pot generates a D.C. voltage proportional to output arm position whose width modulates a standard pulse. This servo-derived pulse is then compared to the incoming pulse from the receiver decoder to generate the

error signal which, again, is a pulse, (although it is much narrower than the information or reference pulse) and it completely disappears when the information and reference pulses are identical.

The decoder in the receiver and the encoder in the transmitter makes use of flip-flops and pulse generators which are considered strictly digital devices. So, you see, although digital systems are not in the truest sense of the word

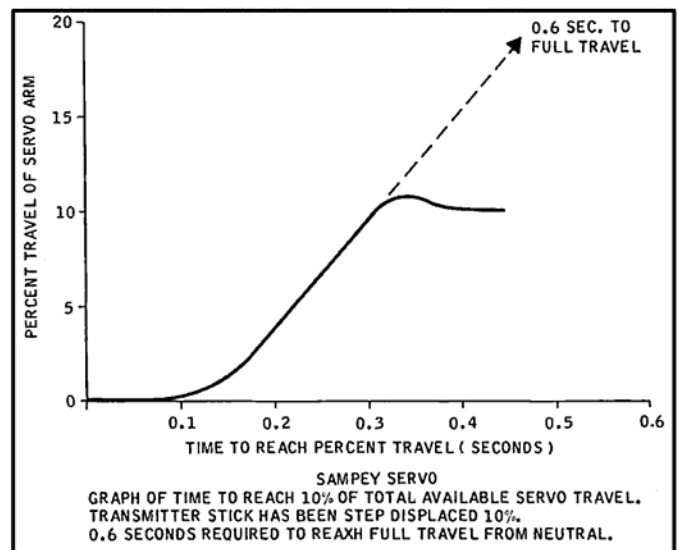
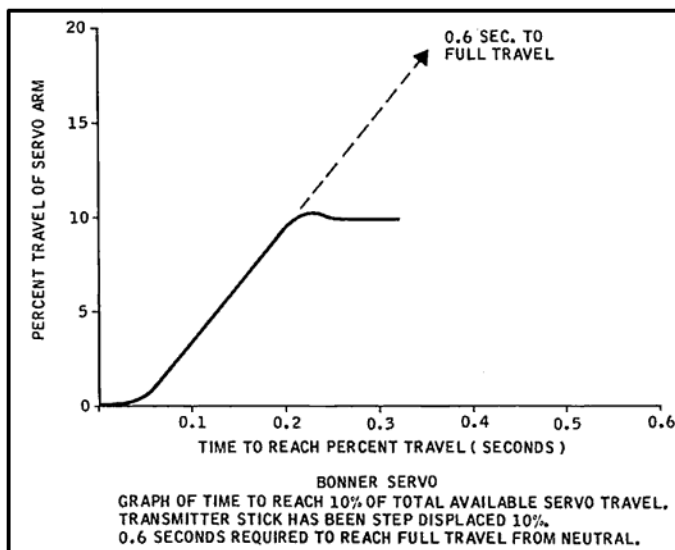

ANALOG VERSUS DIGITAL

(Continued from Page 33)

"digital," they are "close enough for jazz."

The Comparison

The following information can be considered somewhat controversial, but since this publication has always generated and welcomed controversy, I am sure rebuttals will be forthcoming. I do, however, give this comparison to you as honestly and as free of prejudice and bias as I possibly can.

The graphs illustrate the most important parameters of proportional performance — tightness (or repeatability of neutral), and system response time (how fast does the servo respond to a stick movement). The information has been volunteered by the manufacturers themselves, so I cannot be held responsible for its accuracy. (Ed's note: No attempt is

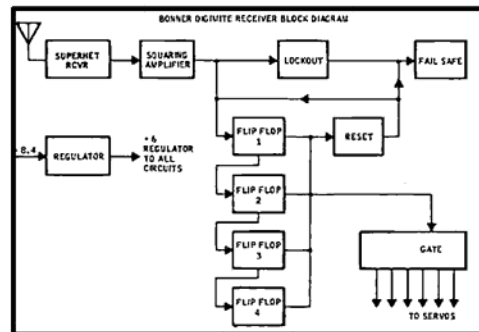
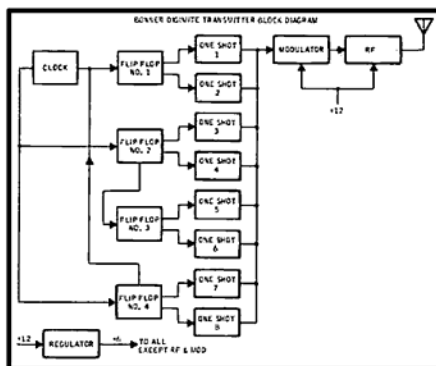
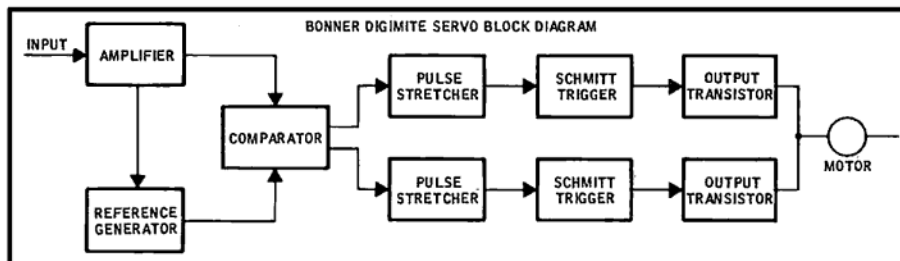

ANALOG V.S. DIGITAL COMPARISON

Analog

Digital

(a) Cost

Orbit Proportional (4 channel): \$595. Sampey Starlite 500: Approx. \$700-\$800.

Bonner Digimite: \$615 (8 channel) F & M Proportional: \$439 (5 channel).

(b) Complexity

Analog wins hands down here. Orbit and Sampey contain approximately 30 to 35 transistors.

Digital systems are by nature more complex — both systems having considerably more than 50 transistors. In time, though, through design simplifications, this number should be cut almost in half.

(c) Reliability

I will have to award the theoretical edge to analog by sheer weight of fewer parts — there are fewer timing functions to get out of adjustment.

Although there are more parts to go wrong with the digital systems, the way in which the parts are used (all on or all off) does help reliability, especially in the servo amplifier.

(d) Maintenance

Here, again, analog wins by virtue of its relative simplicity. The average do-it-yourself electronics "expert" would have an easier job of readjustment.

Digital systems, because of their critical timing functions, will have to be factory adjusted, or where a precision oscilloscope is available.

(e) Ease of Installation

All things considered — a dead heat, although analog fans will have to make sure their linkages are completely free.

A tie, but more power for small error signals make fewer demands on linkage freedom.

(f) Ease of Operation

Again, not much difference, although a slightly different flying technique is required due to slower servo response for small error signals.

It may be easier for the beginner to get used to digital systems, but this is hard to prove.

(g) Servo Action

Analog systems, due to the need for large filtering capacitors at the input to the servo amplifier, have a slower reaction time for small stick displacements, such as in landing flares. This can be compensated for, somewhat,

The digital system servo response is faster and more constant regardless of air load or linkage drag. I am speaking of the time to react, and not the speed of travel once it is going. Obviously, under load, both types will

by experience. The other objection is the fact that sticky linkages may increase the deadband, as will severe air loads.

slow down, but the digital servo will start much more quickly.

(h) General

This is hard to pin down in a few short comments. It depends entirely upon what your standards are. Both types perform well. I will say that digital has the edge in contest precision flying because of its slightly quicker servo action. It should be noted, however, that analog should have better interference rejection due to the tone-subcarriers and discriminators. Analog systems are more prone to neutral shift with temperature due to the "Class A" operation of the servo amplifier. This drift can be compensated for by various means, such as thermistors and silicon transistors.

Digital systems will appeal to the contest flyer — especially the scale buff, because of the additional channels available. Digital's one drawback is that noise, man-made or natural, looks like information to the system. This has prompted both major manufacturers to put in elaborate lockout and fail-safe mechanisms. Digital servos are also less susceptible to drift with temperature due to the fact that the reference generator in the servo should track the pulse generator in the transmitter, thereby cancelling out any temperature caused changes. Since the motor driving circuitry is all on or all off, it contributes no drift affect of its own.

THE PROPORTIONAL CONTROVERSY

TO FAIL SAFE OR NOT

By AL DOIG

*Fail Safe . . . necessary or not?
The author offers an excellent
rebuttal to RCM Editor's point of view.*

Fail safe is generally accepted as the act of returning all controls to neutral, and motor to low speed when any detectable failure occurs in the receiver or transmitter. Like motherhood, it has been generally regarded as "good". In a reed set, all controls will automatically return to neutral (barring certain types of power failures) as a consequence of not transmitting appropriate tones. This is in itself a fail safe mode. Fail safe as applied to reed sets is generally an electronic gadget that returns motor to low speed if any command is not received for a specified period of time and is an add-on unit, not normally a part of the radio. The decision to fail safe or not in reeds is a matter of whether one wants to crash under full or closed throttle! The intensity of the crash depends upon luck and the stability of the airplane.

With proportional, however, the problem is more complex. Many systems use some form of pulse width to control servo position. So-called digital systems use this form of coding. As a wide pulse represents one servo extreme and a narrow pulse represents the other extreme, the absence of a pulse is generally interpreted as a narrow pulse and, there-

fore, a desire for hard-over control. Noise, on the other hand, may appear instantaneously as good information. If a noise pulse, or a cycle of tone signal coincides with a time when information is expected, it is interpreted as a servo position consistent with whatever width the pulse happens to be. A digital system without a fail safe/lockout feature may certainly operate on the face of noise but will be confused because noise will substitute for good information and good information will be shifted from one function to another on a random basis. The servos in this condition will chatter and/or run wildly from one extreme to the other in an erratic manner.

To permit operation of a digital system in the face of ever present noise, some systems contain a function called lock-out. In some way, all systems electronically define "frames" of information. That is, the first pulse or time period of a "frame" may be rudder, the second elevator and so on through however many functions there are in the system. The first pulse of the next frame is again rudder, the next, elevator, etc., etc. Thus, is known how many pulses **should** be in each frame. Lock-out in some way

says "if there are more or less pulses in this frame than there are supposed to be, I will stop the servos right where they are until the information is proper again. When it is proper I will release control to the incoming information stream". In most sets using this system, after lock-out has been in effect for a predetermined time, fail safe is triggered, sending the servos to a neutral position. The first frame of good information will return control to the transmitter.

The decision to fail safe or not is one of economics, and probability. How much did fail safe cost? What is the probability it saved the plane? What is the probability it would have been saved if fail safe had not been in operation, and what is the cost of the ship?

As an absolute minimum, the complete absence of pulses must return the servos to neutral. As a result of a transmitter failure, hard over controls in all channels is, at least to me, completely unacceptable. Statements that some degree of control is attained through interference if lock-out/fail safe is absent are rather misleading. Control may be so erratic, and indeed may be completely switched from channel to channel in a random fashion, as to be detrimental rather than helpful. I'm not so skillful a flier as to diagnose erratic control action when the ship is headed toward destruction. My mind tends to go blank under these conditions. I'd prefer to have the control do something intelligent rather than count on my doing it! To illustrate the above points, I was flying a Stormer with digital proportional when a wire broke loose from one of the control potentiometers in the transmitter. The

(Continued on Page 41)

R/C Design Made Easy

By CHUCK CUNNINGHAM

First in a series of articles on designing radio control models. Read on, grab your sketchpad, and watch for RCM's forthcoming National Design Competition.

The design of Radio Control models is not a complex matter. Most of the successful ships fall into the same general pattern. It is our purpose here to bring to you an easy-to-follow guide to this pattern. The chart accompanying the text should make the basic relationship of each part of the model clear, and remove most of the work of calculating the relative sizes.

If you are an expert on design then you know the following answers already. For you balsa choppers who would like the pride of designing your own ship, but want to be sure that it will fly before you take the time, money and effort to build it, then this article is for you.

The primary type of ship we will investigate is the full house multi craft. The basics of design that we are going to explore, hold true for the single channel rudder ship as well, with but some slight modifications. Are you ready? Got your dream ship in mind? OK, let's go.

POWER. This is the beginning. The size engine that you use will dictate the rest of the design. The main difference between a hard to fly ship and one that is easy to fly is simply a matter of power. The same airplane can be flown very nicely with a .35 in the nose and yet, the same craft can be flown with a .59 mill churning the air. For our purpose let us stick to the .45 size engine for power.

Chart #1 gives a reasonable relation between engine displacement and wing area, and a quick look at it shows that our .45 ship should carry a wing with about 725 square inches of area. Of course, we may use more or less wing area, but to save argument we will use this figure to develop the design of the remainder of our craft.

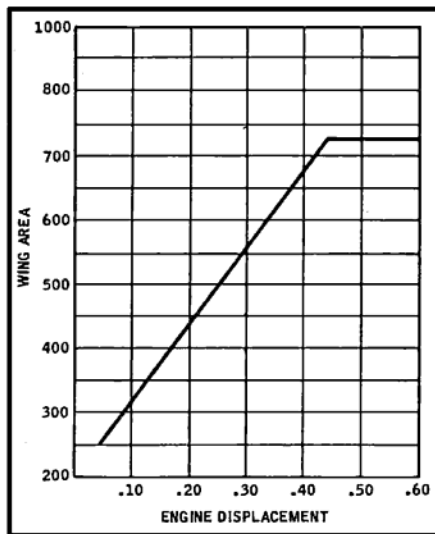

WING. Now that we have determined the total area of the wing we consult chart #2 to find the wingspan and the chord. This chart indicates that the wing span should be 63 inches and the chord should be 11.5 inches. This chart is based upon an aspect ratio (A/R) of 5.5:1. If you desire to use an A/R either larger or smaller then simply fall back on your ninth grade algebra to find the span and chord.

The operating force in the wing is the aileron. The correct size of the aileron has too often been left to chance, and too many times chance has fouled up! The best size for our ailerons is a total of 12% of the total wing area, 6% for each aileron. This amount holds true for either conventional ailerons or the easier-to-build full-span type. If your cup of tea is the conventional variety, then use a ratio of 60% of the half span x 20% of the chord to find the size. For full span the length-width ratio will be dictated by the wing span. The cor-

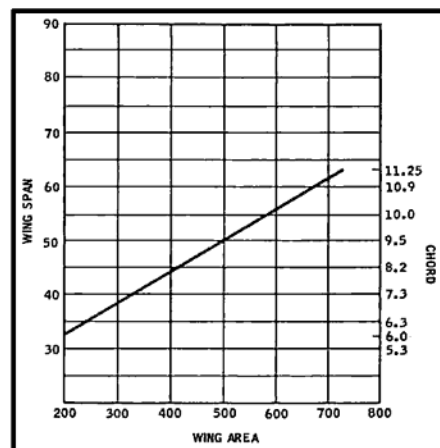

rect aileron size will end forever the problem of too small an aileron, or even worse, too big!

AIRFOIL. Your choice. There are many airfoils that will do a good job, some a lot better than others. Almost everyone has a favorite type. If you have, us it.

HORIZONTAL STAB. Since we have developed our wing size complete with ailerons, we next can find the size of the horizontal stab by consulting with chart number 3. Read the figures on the left side. For our wing of 725 square inches we find a correct size of 181 square inches. An A/R of 3:1 works fine for this surface though you may change this to suit yourself. The elevator portion of the horiz. stab., like the aileron area, should not be left to the eye. A maximum of 20% of the total area will be fine for reeds, and 25% for proportional.

The elevator airfoil has been the subject of much speculation during the past year and many attempts have been made to determine if a thick airfoil is better than a thin one. For our project let us take the middle of the road approach and stick to a symmetrical section of about 8 to 10 percent thickness.

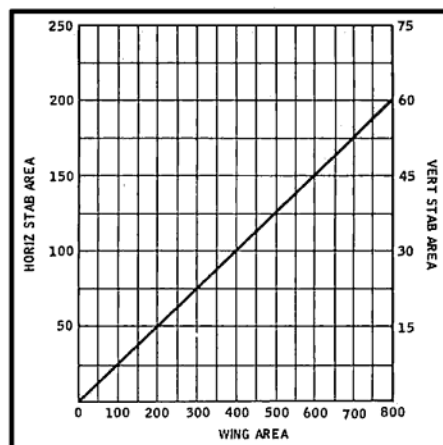

VERTICAL STAB. By again consulting chart #3 and reading the figures to the right we find that for our wing area we have a vertical tail of 54 square inches. The span and chord of this surface I'm going to leave strictly up to you. Whatever looks good and suits your personality and results in enough area is best. Keep in mind though, a vertical stab, with a swept back rudder post is much harder to spin. The rudder area is dictated by the type of control that you are going to use. For the multi ship we are designing, use about 30% of the total vertical stab for the rudder portion. For single channel stick to 10%. OK, Pulse Fans, make it larger for your usage.

FUSELAGE. The main part of our design project is the fuselage. This member will allow your individual attempts to come up with something "different" to evolve. And believe me, it's hard! The placement of the lifting surfaces will remain about the same for any type of craft, either low wing, shoulder wing or high wing, and either multi or single channel type. The overall length of the body should be about 75% of the wing span for the wing that we are utilizing. If you have gone to a lower A/R, then the body length should be increased to allow room for all of the goodies inside, and to provide adequate stability. With a length of 75%, allocate 18% of the total body length to that area (nose moment) between the leading edge of the wing and the back of the prop washer. This should provide for at least a tank size of 8 to 10 ounces. Save 40% of the body length for the space between the wing trailing edge and the leading edge of the horizontal stabilizer (Tail moment).

C.G. LOCATION. The proper CG location will make or break an otherwise good aircraft. For most multi work a CG point of 40% will give outstanding results. The CG is not simply a place on the wing chord, but represents a point at which 40% of the wing area is ahead of it and 60% is behind it. Keeping this thought in mind it becomes a relatively easy matter to find the balance point on swept wing designs.

INCIDENCE & DECALAGE. The angular placement of the wing on the fuselage, with relation to the elevator and to a central line through the body,

is our next step. For most multi work use an incidence and decalage of 0°—0°. If you desire a slight margin of recovery, use one degree incidence.

RUDDER ONLY. The modifications to all of the above for this type of model are actually slight. The size of the wing and tail groups in relation to each other will stay the same as does the fuselage length. The main difference is in power, decalage and down-thrust. For chart #1, simply move up one engine size to find the correct wing area. The angular difference between the wing and stab should be about 3 degrees and down thrust will be in the 5% to 7% range.

LANDING GEAR. The placement of the landing gear will be correct if you locate the main gear 1½ inches behind the CG for a trike gear ship and the same distance ahead of the CG for a two-wheel airplane.

CHART #4. This chart is a thumbnail summary of all that we have shown before. The figures have been determined after much research, study of popular designs, and many original design projects. They all may be juggled somewhat but for all around flying these figures will get the job done. Good luck, and Good flying.

CHART #4 BASIC RELATIONS

1. Wing:
Span=5.5 x Chord (Aspect Ratio)
Ailerons=12% wing area (6% each aileron)
2. Horizontal Stabilizer:
Area=25% wing area (min. of 20%)
Span=3 x chord
Elevator=20% to 25% horiz. stab. area
3. Vertical Stabilizer:
Area=7.5% wing area (5% min. to 10% max.)
Rudder=10% to 30% vert. x tab. area.
4. Fuselage:
Length=75% of wing span
Nose length=18% of fuselage length
Tail length=40% of fuselage length
5. CG Location
Multi=40% of wing area
Rudder=30 to 40% of wing area.

To Fail Safe Or Not

(Continued from Page 39)

system went into fail safe and the plane glided down in the alfalfa without even a broken prop. A field soldering iron fixed the problem and I was back in the air within 15 minutes.

Luck? Yes, but fail safe in this instance saved me 50 bucks worth of kit and material. Fail safe is now worth 50 bucks to me.

Another instance where fail safe helps is one which should not happen but does to the best of them. An instance will illustrate. Cliff Weirick, who is a reasonably experienced flier, fired up his Candy and started to take off. His engine throttled back a couple of times. Cliff looked up to see another flier, whose transmitter had been previously shielded from view, with the same color frequency flag. If Cliff had been able to "control the surfaces through the interference" he would have been about 50 feet in the air when the awful truth became apparent. Fail safe is worth 50 bucks to Cliff Weirick, not to mention the other airplane.

To summarize — I fly a system with fail safe and I'd rather fight than switch.

Engine Obedience Course

(Continued from Page 28)

over a firewall and down to the engine, which is called for by some model designs. A fuel line should be routed so that it is never higher than the fuel level in the bottle when you try to start the engine. Otherwise, the engine may die while digesting the bubble forming over the hump.

For some reason modelers will invariably put a new engine in a new model. This only compounds the likelihood of trouble. Use a well-tested engine in your new model, and vice versa.

Happy Flying,

REGATTA

Rt: Ed Soltis of Yonkers, New York and his white Heat V. F&M 10-channel.

Since Regatta is, and will continue to be, a monthly get-together by and for RC boat enthusiasts, we will from time to time, devote the column to letters from RCM readers. In this manner, it is hoped to stimulate interest not only in general boating activities, but to prompt the boating enthusiast to actively participate in promoting these activities on a national and world-wide scale by viewing his opinions and sharing his ideas and techniques with RC boatmen everywhere.

Sir:

Our club, the Neptune Model Boat Club of Vancouver, B.C., Canada, is six years old this winter with a present membership of fourteen boatmen. We all use multi channel equipment with about 80% on superhet receivers. Each year, our annual Regatta gets bigger and better, and includes entrants from the U.S. Now in the planning stage for our 7th Annual, we hope to include hydroplanes for the first time. We have contemplated joining the IMPBA, but we are in disagreement about their rules and courses, particularly in the electric events. We feel that the human judgement element in awarding points coupled with the various types and sizes of boats that have to compete over the same course, is unfair. Even breaking the entries down in displacement classes is not the answer. For instance, a 21 pound cabin cruiser, stubby and maneuverable, pitted against a long and narrow warship of the same weight class would be less than equitable. If you break the field down into type and weight classes, you would have to have a very large entry in order to afford

any competition in each category. Too, the expense for trophies would be prohibitive.

Our own system, on the other hand, is basically one of competing against your own estimated time plus the score for each buoy. This system does eliminate the problems of time consuming runoffs for tie scores. This gives the contestant with the ability to mentally plot a smooth course through the buoys a deserving advantage. We feel that this also eliminates the "over maneuverable junk boxes" that could turn 360 degrees between a pair of markers. This keeps the quality of models to the high degree most of us like to see. This is how our precision course works:

First, we decide on a reasonably complicated course, then set it up on the lake. Next, we take an average sized boat, such as a 40" tug, run it through the measured timing strip clocked by a stopwatch. We then run the boat through the course a total of six times, timing each run while making smooth curves throughout. The average time of the six runs is then determined, divided by the timing strip time, giving us a **multiplier**. This entire procedure takes only about fifteen minutes prior to contest time.

The multiplier is then used to calculate each contestants estimated time by multiplying their timing strip time by the multiplier. The contestant being scored ten points for each buoy then proceeds through the course, passed through, five points for an inside hit, and zero points for a miss. Buoys are clearly marked by stripes and will spin when touched. Upon completing his run, the difference between the contestant's actual time and

estimated time is subtracted from his buoy score at one point per second (the difference over or under the estimated time is subtracted). Three stopwatches are used — all three started as the boat crosses over the start of the timing strip, with two of the watches being stopped at the end of the time strip. This time is recorded and an estimated time for the course is calculated as the contestant maneuvers to the starting line. On crossing the latter, the two watches are restarted and the run is timed. The third watch is for timing the contestants total allotted time, which in our cases, is three minutes for completion of the course attempt.

We have found this system successful for two consecutive years without any form of problem or argument. In previous years, we used the simple IMPBA course and ended up with about 30% of the contestants tied for first place and another 20% tied for second, which meant reruns to break the scores. This usually ended up with two hours for the event and another two hours of running for tie-breakers. We then tried judging how well each boat maneuvered through the course, but this failed due to the fact that judging of this type is relative to the best run, and if the latter was half way through the day's events, the subsequent runs would be considerably poorer scored than those preceding.

Our 1963 Regatta gave each contestant two runs in the event with 28 boats running twice — the event lasted four hours. The 1964 Regatta featured a one-run "sudden death" event which lasted two hours, giving us more time for other events while limiting the whole contest to five hours. Events included were four



weight classes for Electric, two classes for internal combustion, a beauty event, and two gimmick events.

The past four months have shown a strong interest in hydroplanes, and we have been again contemplating applying for membership in the IMPBA in order to run official events. I, personally, have been primarily an RC flier for almost eight years with boats coming a very close second — especially hydros. In our area, the supply of needed accessories for boat modeling has been strictly from hunger. I would like to compliment Octura Models in their endeavor to fill this huge gap.

George Longmeier,
C/R Chairman
Neptune Model Boat Club

Some good ideas, George — and some food for thought. How about some comments, I.M.P.B.A.?

Sir:

I have been buying RCM ever since your first issue, and I like it. When you started the Regatta feature I was overjoyed, as my RC interests are mainly in boats. Then, when the Roostertail appeared, "I flipped." What a magazine! Great!

So what happened in the December and January issues? No Regatta. I should think that as long as the IMPBA is "tied in" with RCM you would go even deeper into the boating end of this hobby. We have 15 members in our very young club (Nassau Model Power Boat Society, North Bellmore, N.Y.), and all are members of I.M.P.B.A. All of us read RCM and feel as I do. So how about a little more on boats? And get the Regatta back in.

If you need more material for the

column, perhaps the IMPBA members can help.

Al Seidenberg
North Bellmore, N.Y.

"We don't "pull" Regatta to make more room for other material, Al... we simply don't receive enough material on RC boating to make up a Regatta column each month. What we do receive has been generously contributed by Tom Perzentka and Gary Preusse — excellent material that reflects quite a bit of time and effort on their part. But two individuals are limited as to how much time they can devote to sustaining this Regatta section while maintaining their own RC boating businesses — Octura and G.E.M. Models. So, for bigger and better boating sections in RCM — send in your ideas, construction articles, photographs, hints and kinks, gripes and suggestions, etc. You, the reader, will make Regatta whatever you want it to be. Don't sit back and let George do all the work... or, in our case, Tom and Gary.

Sir:

We of the local boating group have enjoyed RCM since the first issue, and want you to know we particularly like the way you have covered boating events. Having had some experience with obtaining material for a monthly deadline, I know that the coverage is given to those areas from which you receive monthly information! Perhaps one of these days the local groups will be as good about contacting you as those in the East.

In another couple of veins, some possible future magazine discussions. First, I feel that a good deal of help can be given the modeler, no matter his RC interest, if something is said

about **Personal liability**. Most organized groups, e.g., A.M.A. and W.A.M. have **some** form of insurance. Some clubs are incorporated at this time, others are investigating incorporation, mainly with the liability aspect in mind. Accidents do happen with RC activity — they can be very serious, and don't always happen to the other hobbyist. **And**, even if this should be the case, other members of a club, association, society, or league can be thrown into the position of having to defend themselves against something someone else did, etc. Of course, you know what I am driving at here. All of us enjoy our hobby in varying degrees — none of us want to lose our drawers because of it! I feel that a comprehensive article by some cooperative attorney and/or insurance man would stand RCM in good stead with an awful lot of readers.

Secondly, I don't know what, if anything, can be done to help, but we need running sites. At the moment, Los Angeles and Orange County boaters are down to Harbor Lake from 11 a.m. to 1 p.m. Sunday only, and Alondra Park lake (with very severe restrictions, concrete walls, etc.). Both are in Los Angeles County... I have been, and am still, looking for something in Orange County... so far with no luck. The Radio Control League of Orange County has been doing some work along these lines. We are more than happy to supply insurance where required by property owners and to police our activities and the grounds — **if** we can just find someone, someplace willing to go along with us!

William A. Baugham

The Roostertail



The Official Publication of the International Model Power Boat Association
General Office: 2405 19th Avenue Broadview, Ill. 60155

The date for the International meet has finally been settled. The National Hobby Center in Cape Coral, Florida has been selected as host for the 16th Annual Regatta of the International Model Power Boat Association, July 3-4, 1965, according to Joe Miller, Jr., executive director for the hobby center. Arrangements have been completed to utilize the Waltzing Waters Lagoon in the multi-million dollar Cape Coral Gardens as the site for the meet. The complete schedule of the Regatta events will be announced at a later date by Mert Mischnick, IMPBA prexy. The National Hobby Center is a non-profit corporation representing more than 24 million hobbyists in the U.S.

Many requests for the "missing parts" of the December 1964 Roostertail have prompted us to repeat the missing section. If there is enough interest in this event, we will run it at Cape Coral:

Try this system the next time you have two boats at your pond. Run each boat for one lap around the course. Time these laps — these are the time trials. Write the times down on paper and subtract the faster time (smaller number) from the slower time. Multiply the difference by .8 (80%) and you have a handicap factor to multiply by the number of laps you intend to run for your race, giving you a total handicap. Start both engines and hold them at the start. Release the slower boat first. Hold the faster boat in port for the time of the handicap, then release. The finish should be quite close since the slower craft had a head start and ran without interference for the first part of the race. The faster boat must

overtake the slower model and pass it to win. Since engines and boats vary from day to day, it is suggested that the time trial figures be used for one day only. Naturally, any changes to the model in the way of fuel, needle valve settings, prop, weight, etc., which effect the speed cannot be permitted without first running another time trial on the model.

For example: Boat A completes one lap in 40 seconds. Boat B completes one lap in 30 seconds; $40 - 30$ equals 10 seconds. $10 \times .08$ equals an 8 second handicap factor. If you want to race five laps, then 8 seconds time 5 laps equals a 40 second total handicap. Boat A (slower boat) is then released 40 seconds ahead of Boat B. The slow boat would, therefore, have a 40 seconds lead.

If you like this system, let us know! We can't see you shaking your head while you read this!

Multi Boat Racing Rules—Part II Section II. Specific Regulations

A. Prior to the start of the match:

1. Contestants must run right only (clockwise).

2. Entrants must make it **their own responsibility** (a) to know the location of the **start or lap line**, (b) to know the location and characteristics of the **visible clock**, (c) to know the designated pit area, (d) to observe any restriction on location for transmitter operation, (e) to check for frequency non-interference of transmitter.

3. Each entrant shall be allowed one pitman to help in servicing and starting the boats. At the end of port time, pitman will take a position behind the contestant in order not to

obstruct the view of the course. Pitman may be used to help in tracking laps during the course.

B. Port time (phase one — starting engines)

1. A maximum port time of three (3) minutes is allowed for the starting of all engines and to allow all boats to be placed under way.

2. Should all entries have started their engines and released their boats prior to the end of port time, the next phase of the contest will immediately commence.

3. If no entrants have started engines and if no entrants are under way at the expiration of port time, a **no contest** shall be declared.

4. If, at the expiration of port time, one boat is under way and others are still in the process of starting and **not** underway, the operating boat will be allowed to start the next phase of the race in ordinary manner. The second or other boat(s) may continue to attempt to start engines and get under way as long as a prior boat is in the process of normally running the course.

5. Should a single entrant complete all phases of the match before any other has succeeded in starting his engine, that entrant shall be declared the winner.

6. If a second, or other boat, gets underway during the time the first is operating, it may be declared winner if it succeeds in finishing all phases of the race before the prior starting boat. This also applies if the prior boat ceases to operate **after** the second or other boat is underway, and before completing the required laps.

7. If the prior boat ceases to operate before completing the required laps and before the second or other boat(s) are under way, a **no contest** shall be declared.

C. Clock Time. (Phase Two — Starting the Match)

1. Clock time is initiated upon the announcement to all entrants by a judge simultaneously with the starting of the one minute visible clock which action occurs in one of the following ways: (a) this action will occur at expiration of port time should any engine be yet unstarted or any boat not yet be underway, (b) this action will occur before the full expiration of allowable port time should all entrants be started and all boats be under way prior to the three minute maximum.

2. Boats now on clock time will adopt a circling or other pattern of

motion back of the start line in such a manner as to best estimate both course and speed with the movement of the clock in order to cross the start line at full throttle and with a running start as the gun is fired at the expiration of the clock time interval.

3. If by the decision of the judges, a boat crosses the start line before the gun is fired to start the race, that boat must proceed around the first set of buoys and then recross the start line for a legitimate and official start.

4. As boats cross the start line they commence the first lap of the race and Phase Three begins.

Contest Calendar Dates

April 24-25. Blue Dolphins Regatta. Lake Woolomes, Delano, California. St. 1/16 and 1/4 Mile Oval.

June 20. Racine Wing & Hull Club. Zoo Park (in Duck Pond). Racine, Wisconsin. Precision R/C only.

August 22. Racine Wing & Hull Club. Place to be announced. Racine, Wisconsin. R/C Speed only.

Thanks to Ed Soltis, Yonkers, N.Y. for the fine color pictures (reproduced in black and white) of his White Heat V with O&R engine, and F&M 10-channel gear. Ed uses two channels for rudder, two for trim rudder, two for throttle, and one for ignition cut-off. A mighty fine looking craft and radio installation.

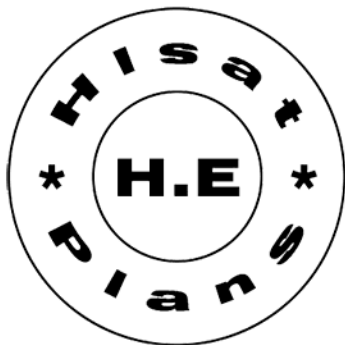

A.M.A.

WASHINGTON REPORT

F.C.C. To Rule on Petitions

Dr. Walt Good Reports on CIAM

F.C.C. Ruling Due On Frequency Petitions

The Federal Communications Commission has been reviewing, since December 8, the dockets submitted by the AMA Frequency Committee with a ruling on the first phase expected shortly. A communique from the Chairman's office of the F.C.C. to Senator Brewster of Maryland advises that a "public announcement concerning the Academy's petition can be expected in the near future."

The AMA Frequency Committee, in effect for almost two years, has raised the largest amount of money to carry on a project of any group within the history of the Academy. The total contributions to the Fund at the end of 1964 totaled \$8,600. In view of the amount on hand, requests for additional funds will be suspended until further notice. Legal counsel and representative for the AMA is Mr. Jeremiah Courtney. Through the efforts of Mr. Ray Benton, Maryland's Senator Brewster has lent his assistance in promoting the RCers cause for additional frequencies.

Howard E. Johnson

New AMA Prexy

Howard E. Johnson, of Los Angeles, California, has been elected President of the Academy of Model Aeronautics for a two-year term beginning January 1, 1965. Johnson, 57, is an active West Coast modeler, and has been a leader in contest organization and model club activities for many years, specializing in free flight. He succeeds Maynard L. Hill of Silver Spring, Maryland.

Five of the Academy's eleven Vice Presidential offices, forming the Executive Council, were up for election for two-year terms. Elected were Carl Schmaedig, Clark Township, N.J.; Dean S. Wright, Warrington, Fla.; and C. O. Wright, Topeka, Kansas. Re-elected were John K. Ross, Dover, Mass., and Don Cameron, Brook Park, Ohio.

1965 Nationals Slated for Willow Grove NAS July 26-August 1

The 34th National Model Airplane Championships will be held at Willow Grove Naval Air Station, Willow Grove, Pa., July 26 through August 1, according to the Academy of Model Aeronautics. More than 200,000 spectators are expected to visit the Willow Grove NAS during the week long event. Spectacular air demonstrations will be provided by the Navy's famed Blue Angels aerobatic team.

With the forthcoming RC World Championship in Sweden there were many RC action items on the agenda of the annual Fall meeting of the Committee for International Aero Modeling (CIAM). The CIAM met in Paris on November 20 and 21, 1964 and was attended by 17 countries.

The new items adopted include a definition of RC prefabrication, a new method of judging for RC World Championships, and two new RC World Record categories.

1. 1965 RC World Championship in Sweden, August 9-15

The Fourth World Championship for RC will be held at an airbase at LJUNGBYHED (pronounced Young-by-head) which is about 30 miles north of Malmo in the southern tip of Sweden. Malmo is just across the strait from Copenhagen, Denmark. The schedule runs from August 9 to 15:

August 9	Arrival
August 10-11	Practice flights
August 12-13-14	Official flights
August 15	Departure

The accommodations are military barracks for the competitors and officials. Nearby small towns have hotel and other rooming facilities for visitors.

(Continued on Page 46)

Washington Report

(Continued from Page 45)

Arrangements are being made for handling the flights of 40 to 50 pilots. Each pilot has one flight per day. The organizers are not concerned with a limitation on daylight hours since the sun rises at 4 a.m. and sets at 10 p.m. at that time of year!

2. Prefabrication in RC Models

Since the FAI rules require the pilot to be the builder of the model, it was necessary for the CIAM to clarify the permissible degree of prefabrication.

For the purpose of clearly defining the RC model which is acceptable at the RC World Championship in Sweden and thereby instruct the contestants and the jury, the following was adopted:

A. Permitted

A plane which is assembled by the builder from prefabricated parts and in which the builder installs the equipment is permissible.

For example — this would permit a builder to use prefabricated engine, propellers, radio equipment, servos, fiberglass fuselages, poly-foam wings, etc.

B. Not permitted

A complete, ready-to-fly RC model which has been built by a person other than the pilot will not be permitted.

3. A New Method for Judging the RC World Championship

In the past, five judges from five different countries have judged *all* flights of all contestants for a three-day period. With the increased entry list, this has become a rather fatiguing duty. Hence, a new system of RC judging was adopted for use at the 1965 World Championship in Sweden. The

new system has the following characteristics:

- a. Use 6 judges (ABCDEF) in 3 crews (ABCD), (CDEF), (EFAB).
- b. Each judge will score 8 flights and rest for 4 flights.
- c. Each crew of judges scores each contestant once.
- d. Every judge will score each contestant twice.
- e. All scores from 4 judges will be added to determine the contestant's score for each flight.

f. The three flight scores for each contestant will be added to determine the list of winners.

The table below shows how the 6 judges will be distributed during the three flights:

The purpose of this proposal is to give each judge a rest period so that his judgement will not become erratic due to fatigue.

Note that consistency of flight performance will be very important because all three flights will be counted in determining the final results. Belgium plans to use this system in the Criterium of Aces Control Line meet in 1965 to determine its usefulness for CL Stunt.

3. Change in RC Flight Time

The flight time for the FAI-RC maneuver schedule was dropped from 15 minutes to 12 minutes. This time includes the engine starting period as before. This purpose is to permit more contestants to fly in a given interval of time.

5. Number of Models

If, after official checking, a model is lost or damaged, the competitor shall have the right to present a third model for checking, up to one hour before the official starting time of the contest. Contestants to fly in a given

	1st Flight	2nd Flight	3rd Flight
Contestant 1	Judges ABCD	Judges EFAB	Judges CDEF
Contestant 2	Judges ABCD	Judges EFAB	Judges CDEF
Contestant 3	Judges ABCD	Judges EFAB	Judges CDEF
Contestant 4	Judges ABCD	Judges EFAB	Judges CDEF
Contestant 5	Judges CDEF	Judges ABCD	Judges EFAB
Contestant 6	Judges CDEF	Judges ABCD	Judges EFAB
Contestant 7	Judges CDEF	Judges ABCD	Judges EFAB
Contestant 8	Judges CDEF	Judges ABCD	Judges EFAB
Contestant 9	Judges CDEF	Judges ABCD	Judges EFAB
Contestant 10	Judges EFAB	Judges CDEF	Judges ABCD
Contestant 11	Judges EFAB	Judges CDEF	Judges ABCD
Contestant 12	Judges EFAB	Judges CDEF	Judges ABCD
Contestant 13	Judges EFAB	Judges CDEF	Judges ABCD
Contestant 13	Repeat pattern as above		

interval may have only two models at the start.

6. RC World Record Categories

With the increased interest which has been shown in RC world records, two new categories have been adopted, effective January 1, 1965, which should make the glider slope-soaring enthusiasts happy!

a. RC glider — Speed — Category 33

It was adopted that the Speed category for RC Gliders be conducted in a manner similar to that for RC powered models. The glider must make two passes through the course in opposite directions during one flight. It is recognized that this will be most easily done under slope-soaring conditions. Since there are many countries with slope-soaring facilities, this event should provide an appropriate record category.

The following additions will be necessary to the FAI Sporting Code, Section 4:

New — "6.10.3 — BASE FOR SPEED RECORDS

"For speed records in a straight line for models with piston type motors, the base must be 200 meters (656,16 ft.), and of 50 meters (164,04 ft.) for radio controlled gliders, and it must be traversed in both directions without any intermediate landing.

"The altitude of the model must remain below 30 meters during the 100 meter entry and the 200 meter course for models with piston type and below 20 meters for radio controlled gliders during the 25 meter entry and the 50 meter course. These altitudes are measured from the point where the pilot is standing".

b. RC Glider — Distance in a Closed Circuit — Category 34

The purpose of this category is to steer the glider for the maximum number of laps around two pylons during one flight.

The FAI Sporting Code, Section 4, will be modified as follows:

New — "6.10.2 DISTANCE IN A CLOSED CIRCUIT

"In the case of distance records in a closed circuit, the length of the circuit must be over a straight base of 500 meters (1640,0 ft.) for models with piston type motors, and of 100 meters (328,08 ft.) for radio controlled gliders".

New — "6.2
Since there is no statement con-

cerning the difference between two consecutive records for Distance in a Closed Circuit, it was adopted that the following be added:

New — "6.10.2(a)

"All new records must beat the preceding record by at least 10%".

New — "6.10.5 — LAUNCHING OF RC GLIDERS

"For the purpose of World Records, the radio controlled glider may be hand-launched or launched by means of a cable whose length does not exceed 300 meters when subjected to a tensile load of 2 kilograms. The person and device pulling the cable must remain on the ground".

7. RC World Record Changes

a. Combining Record Attempts

The following applies to combining distance in a straight line with a duration record attempt:

6.10.1(b) add:

"In the case of a successful record attempt for distance in a straight line, the duration may also be homologated".

b. Use of Assitant Pilots

For the purpose of establishing RC World Records, the CIAM ruled that assistant pilots are not permitted. Since this was never stated explicitly in the Sporting Code, this rule does not apply to past records but will become effective January 1, 1965.

8. 1967 RC World Championship set for Germany.

9. RC Judges Guide

The FAI-RC Judges Guide officially considered to be a part of the Sporting Code. The integration will occur at the next reprinting of the Code. Also, the CIAM plans to generate a new RC maneuver schedule which would be first used in 1966.

10. Other European RC Events in 1965

For travellers to Europe in August 1965, there are two International RC contests in addition to the RC World Championship in Sweden:

1. August 21-22, 1965, Stockholm Sweden
2. August 28-29, 1965, Munich Germany

11. CIAM-RC Subcommittee for 1965

- | | | |
|-----------------|----------|-------------|
| H. J. Nicholls, | Chairman | England |
| A. Roussel | | Belgium |
| N. Trumfheller | | Germany |
| A. Degen | | Switzerland |
| G. Hofmann | | Sweden |
| P. Marrot | | France |

