

# RADIO CONTROL MODELER

AMERICA'S LEADING PUBLICATION FOR  
THE WORLD'S FASTEST GROWING HOBBY

CDC

OCTOBER 1964 50c



1964  
nats  
issue



The **KWIK-FLI**  
By **Phil Kraft**



## Λίγα λόγια για μένα.

Είμαι Μηχανικός Ηλεκτρονικός και αυτό είναι το αληθινό μου επάγγελμα εργασίας.

Από μικρός δυο πράγματα μου κέντρισαν το ενδιαφέρον και ασχολήθηκα με αυτά.

Πρώτον ο ηλεκτρισμός και δεύτερον το απέραντο γαλάζιο του ουρανού και ο αέρας αυτού.

Το χόμπι του αερομοντελισμού το πρωτογνώρισα τον Οκτώβριο του 1973.

Μου αρέσουν οι ξύλινες κατασκευές αεροπλάνων και σκαφών από το μηδέν.

Ξεκίνησα να συλλέγω σχέδια, άρθρα, βιβλία και ότι άλλο μπορούσε να με βοηθήσει στο χόμπι από τα πολύ παλιά χρόνια.

Έχω δημιουργήσει μια πολύ μεγάλη προσωπική συλλογή από αυτά.

Από το 2004 άρχισα να ασχολούμαι με την ψηφιοποίηση τους, τον καθαρισμό τους αλλά και να τα μοιράζομαι μαζί σας αφού τα δημοσιοποιώ στο διαδίκτυο (όσα από αυτά επιτρέπεται λόγω των πνευματικών δικαιωμάτων τους).

Σήμερα μετά από όλη αυτήν την εμπειρία που έχω αποκτήσει, αποφάσισα να ψηφιοποιήσω, να καθαρίσω και να ξαναδημοσιεύσω σε ψηφιακή έκδοση και ελεύθερα όλα τα τεύχη του περιοδικού RC Modeler από το 1963 μέχρι το 2005.

Σίγουρα είναι μια πολύ μεγάλη, δύσκολη και επίπονη εργασία αλλά πιστεύω με την βοήθεια όλων σας να την τελειώσω σε ένα καλό αλλά μεγάλο χρονικό διάστημα.

Ζητώ συγγνώμη εκ των προτέρων γιατί τα Αγγλικά μου είναι φτωχά.

Δεν είναι η μητρική μου γλώσσα γιατί είμαι Έλληνας.

Εύχομαι σε όλους εσάς που θα επιλέξετε να τα συλλέξετε και να τα διαβάσετε αυτήν την εργασία μου καλή απόλαυση και καλές κατασκευές.

Το όνομα μου είναι Ηλίας Ευθυμιόπουλος.( Η.Ε )

Το ψευδώνυμο μου Hisat.

Η χώρα μου η Ελλάδα και η πολη μου η Ξάνθη.

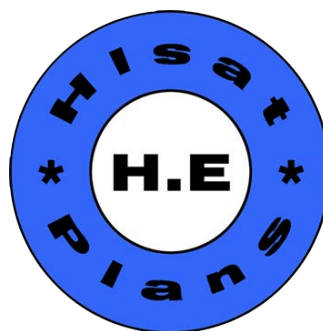

## **A few words about me.**

I am Electronic Engineer and this is my true work job.

From small two things attracted my interest and I dealt with them.

First electricity and secondly the blue sky and the air him.

The model aircraft hobby met him in October 1973.

I love the wooden structures from scratch airplanes and boats.

I started collecting plans, articles, books and anything else that could help the hobby of many years ago.

I have created a very large personal collection of them.

Since 2004 I became involved with the digitization, clean them and to share with you since the public on the internet (as many of them are allowed reason of copyright).

Now after all this experience I have decided to digitize, to clean and to re publish in digital edition and free of all issues RC Modeler magazine from 1963 to 2005.

Certainly it is a very long, difficult and tedious task but I believe with the help of all of you to finish in a good but long time.

I apologize in advance because my English is poor.

It is not my mother language because I am Greek.

I wish all of you who choose to collect and read this my work good enjoyment and good construction.

My name is Elijah Efthimiopoulos. (H.E)

My nickname Hlsat.

My country is Greece, and the my city is Xanthi.

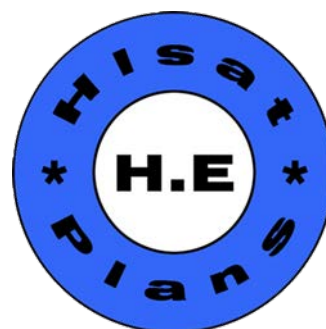

## **RCM Magazine Editing and Resampling.**

### **Work Done:**

- 1) Advertisements removed.
- 2) Plans building plane removed and hyperlinked.
- 3) Articles building plane removed and hyperlinked.
- 4) Pages reordered.
- 5) Topics list added.

**Now you can read these great issues and find the plans and building articles on multiple sites on the internet.**

**All Plans can be found here:**

**Hlsat Blog RCModeler Free Plans and Articles.**

<http://www.rcgroups.com/forums/showthread.php?t=2354459>

**AeroFred Gallery Free Plans.**

<http://aerofred.com/index.php>

**Hip Pocket Aeronautics Gallery Free Plans.**

[http://www.hippoketaeronautics.com/hpa\\_plans/index.php](http://www.hippoketaeronautics.com/hpa_plans/index.php)

**James Hatton Blog Free Plans and Articles.**

<http://pulling-gz.blogspot.gr/?view=flipcard>

**Vintage & Old-Timer RCM Free Plans.**

<http://www.rcgroups.com/forums/showthread.php?t=2233857>

**Contributors:**

**Scanning by ser001**

**Editing by Hlsat.**

**Thanks Elijah from Greece.**

# R/C Modeler

October 1964 Vol.1 No. 11

Lt: Man of the Year,  
1964 R/C Nationals winner,  
Cliff Weirick with  
winning Candy  
design and Bonner  
Digimite proportional.

## CONSTRUCTION

23 KWIK-FLI (by Phil Kraft)

## FEATURES

DON DEWEY  
*Editor*

09 1964 NATIONALS NATIONAL DATA

CHUCK WAAS  
*Managing Editor*

30 SHEETS PRODUCT REPORT: BABCOCK

KEN WILLARD  
TED STRADER  
FRANK JUSTIN  
*Associate Editors*

30 BC-21 PRODUCT REPORT:

CLIFF RAUSIN  
*Foreign Editor*

35 QUADRUPLEX 21

HENRY J. NICHOLLS  
*Contributing Editor*

GEORGE WALKER  
*Art Director*

## DEPARTMENTS

BARRY HALSTEAD  
*Art Assistant*

4 DEAR RCM:

GIL DUARTE  
DICK TICHENOR  
*Photography*

3 EDITOR'S MEMO (by Don Dewey)

BILL O'BRIEN  
*Consumer Research*

GORDON MADISON  
*Plans Service*

5 SOLO (by Frank Justin)

MERT MISCHNICK  
*I. M. P. B. A.*

7 ROOSTERTAIL (by Mert Mischnick) FROM

GEORGE WELLS  
*A. M. A.*

32 THE GROUND UP (by Ted Strader)

PAT McCLOSKEY  
*Administration*

41 COMMENT (by George Wells)

JOYCE STOLPE  
*Editorial Assistant*

38 SHOWCASE '64

SHIRLEY BYERS  
*Reader Service*

GEOFF FRANKLIN  
BILL MURRAY  
DAVE SKINNER  
MONTE MALHERBE  
JACK ALBRECHT  
JOHNNIE CARROLL  
PER-AXEL ELIASSON  
*Correspondents*

R/C MODELER is published monthly by the R/C Modeler Corp., Sierra Madre, Cal. Contents copyright 1963. All rights reserved. Printed in the U.S.A. Second Class Postage paid at Sierra Madre, Calif. SUBSCRIPTION RATES: Annual (12 Issue) subscription, U.S. & possessions: 5.50; 2 years, 10.00. Canada: 1 Year, 6.00. All other countries: 1 Year, 6.50. Payment from all countries must be made in U.S. funds. Changes of address must be sent to R/C Modeler as well as to the local Postmaster to insure forwarding. Send old address with the new. Canadian Circulation P.O. Box 3005, Vancouver, B.C., Canada.

The 1964 Nationals are over, and RCM is proud to present a chronicle of the events of what will undoubtedly be remembered as the finest Nat's of all — a meet that was a fitting tribute to the contestants who participated, the AMA who conducted the annual competition, and to the U.S. Navy for their untiring efforts in the modelers behalf. In this annual Nat's issue, we have tried to present as wide a picture as possible of the week-long affair, tying it together with the data on each individual entry. Although we have had to delete several of the regular monthly features in order to bring you this coverage, they will be resumed next month.

And — although the 1964 Nationals are over for the contestants, they are really just beginning for RCM readers. The winning Class III design, Cliff Weirick's 'Candy,' along with the victorious Junior-Senior Class I machine, the Mark I, have already been presented in RCM. Phil Kraft's fourth place Class III ship, the Kwik-Fli, is included in this issue. Coming up is Lloyd Sager's winning Class II design and Zel Ritchie's 1963-64 second place Class III ship, the Phantom.

If you're not of the hardware collecting nature, here's a few other up and coming projects ... a fantastic Class III delta from the South American Nationals Champion ... the world's smallest biplane for single channel proportional, and a companion transmitter and pulsar... an outstanding aileron only design from Tokyo ... a completely scale Hawker Hurricane that can equal many of the top contest ships in Class III... several Class I and II sport designs... a quickie .020 that can be built in one evening... a complete photographic tour of the O.S. engine factory... a do-it-yourself article for building an electronic relay checker ... a scale Gee Bee ...

... and that's just a short preview. There will also be the first of our Annual Design Contest for electronic and model construction features, so sharpen up the pencils !.. it'll be worth it!

We were going through some back issues of some of the other model magazines and we noticed Model Airplane News Editor Walt Schroeder's first column after taking the reins from Bill Winter. The date was August, 1960, and a little sign hung on the masthead that read, "Gone To The Nats." This is Walt's fourth anniversary as editor of one of the greatest model magazines in the world. Since that first column he has not only produced a fine periodical, but has fought for, and obtained, many of the benefits we enjoy in model aviation today — and obtained them with a sense of honesty and integrity that bespeaks the man behind that byline. Modeldom owes Walt Schroeder a great debt — we salute you, Walt, and Happy Anniversary.

We mentioned Bill Winter... being the junior member of the League of Overworked Editors I'd like to mention Bill's new book, 'How To Build R/C Models,' which should be available at your local hobby shop or through the publisher, Kalmbac Publishing Company. Bill is not one to toot his own horn, so we'll do it for him ... if you're a newcomer to R/C (or an oldcomer with troubles, maybe?), this book will help you avoid a lot of pitfalls. So what are you waiting for?

And that's it for this month ... if you're reading this rag and the sun's still shining, you're procrastinating. Go out and fly. If you smash up your radio gear, don't worry about it — just pick up RCM and look through the ads and buy some more. Our advertisers won't mind — they'll buy more space and I'll get wealthier and maybe even buy a new Mustang like Charlie, Our Managing Editor. Our Status Symbol, Charlie. A nice guy, but a Status Symbol.

Geronimo.

## EDITOR'S



**Don Dewey**

## Memo



## R/C MODELER MAGAZINE P.O. BOX 487 SIERRA MADRE, CALIF.

### The Nationals . . . 1964 Style

I'd say it was a scoop! — the way you were able to get photos of the Nat's in RCM and distributed nationally in just a couple of weeks! Terrific — just like Time, Inc. Congratulations!

Seriously, though, there are many modelers such as myself who truly appreciate efforts such as this, not being able to take in all the big meets. In this instance RCM kept me from chewing up my fingernails waiting for Nats news in one of the **slower** model magazines.

David W. Jones Cave Creek, Arizona Just finished reading your September issue and enjoyed it very much ... I would like to make a correction on the photo of my husband Pete Petri (p. 44) — the photo is that of Mr. Kleinburg and his airplane. My husband flew an airplane he designed, and that we named the "Air-Conditioned." Enclosed is a photo of him with one of the trophies. He tied Tom Williams for highest total points of the meet as well as second place in Class I. We want to thank you for the coverage and know how rushed you and your people must have been, to get these photos in the September issue.

Mrs. Estie Petri San Antonio, Texas I have just finished reading your September issue from cover to cover and would like to offer my congratulations. In the past three years of combing several different airplane model magazines, I must say that this month's copy is tops. As a novice multi flier, this magazine is jam-packed with my kind of material. I hope we see a continuation of this

type of publishing. It is not my habit to write a compliment of a good article or magazine but I really felt obligated to express my appreciation.

Robert L. Mothersbaugh  
Cuyahoga Falls, Ohio

*Our thanks to the many readers for their letters concerning the early Nat's coverage — OV Charlie, RCM's Managing Editor, was using Missile Mist in the Cessna on the way back from Dallas. Since our Editor not only goofed on the caption under Jerry Kleinburg's photo, but referred to Don Crow's \*Miss Witchkraft' as a Stormer, we think he was drinking the stuff!*

### More About Switches

Read with consternation the bit "That's A Switch" from Ronald Kauffman in Dear RCM (Aug. '64). After struggling through all the known varieties of switches including military spec micro switches, and finally turning to AJco switches, I would like to know where we go from here? As far as I am concerned, I wouldn't touch a micro-switch with a ten foot pole— I have had at least three known instances of micro-switch failure, and after taking several apart and looking them over, I can understand why. All I can say to the electronic industry is — help! Do you have any recommendations?

Don Lowe

*Phil Kraft has spent some time searching for switches that will work consistently without failure. It looks like he finally found the answer with his new switch — see page 61 of the September issue.*

### Airfoils for R/C

Where and how can I obtain ordinates for airfoil sections that would be suitable for R/C Multi contest designs. Can you recommend specific ones? In a progressive airfoil wing should the tip section thickness be more or less than the root section for reduction in tip-stalling tendencies? When using the progressive airfoil wing, is there any advantage in having a semi-symmetrical center section and a symmetrical tip section?

C. L. Steyn

Bloemfontein, South Africa Rather than get into an involved technical discussion about airfoils, we would suggest you obtain a copy of Frank Zaic's new book, 'Circular Airflow arid Model Aircraft,' an excellent treatise on the subject. It's available from Frank for \$3.00 at Box 135, Northridge, California. A most, unusual book highly recommended to every RC'er.

### A Request Fpr Assistance

Do you know of any R/C modelers in the Fort Worth, Texas area who would like to help a Part 15 operator get into R/C modeling? If you do, please let me know.

Wiley · Clarkson

129 Williamsburg Lane  
Fort Worth 7, Texas



In the beginning, man created R/C and the great birds did rise from the ground on tires of rubber . . .

Then Gee-Ree put out a set of pontoons and I bought a set. Two years ago, Yours Truly vacationed in Northern Wisconsin on Trout Lake — the family had such a great time we knew we had to go back, and this was the year. To give an idea of what the attraction is, consider a beautiful lake, nine miles long, that after a few parcels of lakefront were sold in the '20's, the state claimed the rest and closed the lake as a game refuge. Today, it is rare to see more than two outboards and a sailboat at one time on this lake — perfect for those who like to ROW . . . the planes, I mean.

So this was the program — construct a Jenny with 10 channel gear, tack on a K & B .35, and strap to a set of Gee Bee pontoons. Leave the wing to build in Wisconsin in order to make everything easier to ship. The Jenny is a DeBolt quick-build kit that should be very successful. The materials are good, construction simple, and it flies. Mr. DeBolt has a very clever way of identifying parts — he measures them all and then lists all these measurements in the top right hand corner of the plans, together with appropriate descriptions. This is great fun. However, I intend to write Mr. DeBolt and tell him about a new invention called the “rubber stamp.” With this device, it is possible to mark things like F-1 or W-12 on parts and even mark the plans with corresponding F-Ts and

W-12's. This, also, is great fun. But, I digress.

We finished the Jenny and put it in the swimming pool to see how she looked — it looked ready. We spent the following afternoon drawing plans for a packing box that would withstand 2400 miles of rail travel, protect the airplane, and not weigh 600 pounds. Even this was accomplished, the cover nailed on, and the crate banded with steel strapping.

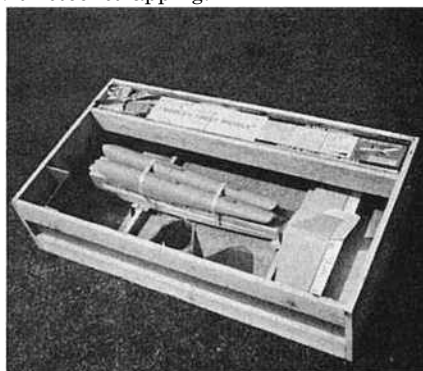

*Via Chicago, sans dope and fuel.*

We were dissuaded from sending the ship via rail express by some friends that were going by train and had plenty of baggage allowance. This sounded good, so we even managed to get the crate to the Santa Fe depot several days before train time to insure its being there and waiting. Yeah, you guessed it — one other mistake was to leave out fuel . . . no flam-

## FRANK JUSTIN

*Frank's back from the wild Northwest read his hilarious account of the Big Man, the Electric Box, and the Toy Airplane.*







*An RCM exclusive — first published photo's of the Monster of Loch Ness.*

mables and dope ... a mess if the can popped open.

We flew to Chicago, picked up a car, and headed North. This was the time to buy fuel and dope, but I kept putting it off until the "next town." Very quickly the "next town" was about 5000 in population and they were getting smaller all the time.

Merrill, Wisconsin, got my business. Stopping at the largest hardware store I could find, I asked for a quart of butyrate. Without a moment's hesitation, the clerk asked, "What's that?" Finally I asked, "Where do all the little kids get those model airplanes on a string that all those little kids play with?"

"Oh!" he replied, "at the TV repair shop."

How about that? It took a little time to convince the TV man that my set was working okay, and that even though I weigh 230 pounds I do play with model airplanes. I asked for a gallon of K&B 100. I bought sixteen half-pint cans of Testors 39 — the complete stock. At least I got the gallon price — this is not surprising because on opening the case, all the cans were rusting — real late stock! Dope was next — as it worked out, the wing was half butyrate and half nitrate!

After making Trout Lake and get

ting the family settled, we got right over to the, railroad and presented our claim checks. The station master did not recognize a claim check. Why? Because this station is not a baggage stop. Who is? Green Bay. How far is Green Bay? 240 miles. Do they have my baggage? I will wire them, come back tomorrow for an answer. ...

... I came back tomorrow and the door was locked. It was Saturday and the station master doesn't work on Saturday. What's more, the following day is Sunday and nobody works on Sunday.

Monday we talked. I bought a beer for my station master friend and he allowed as how if the baggage isn't at Green Bay it might be in Milwaukee or maybe it ain't even out of Chicago yet.

It seemed best that I find my own baggage. We called friends in Chicago who kindly presented themselves to the Santa Fe baggage room, made physical contact with my crate, and saw it leave via Rail Express for the Northlands. Not only did it arrive, but it arrived in perfect condition — a tribute o modern transportation and time.

We started construction of the wing it once. Remembering that the Jenny's we had seen back in California all had

some degree of full length planking to beef up the wing, we decided to stick to the plans. "Its flexibility is the keynote to its strength," is said.

The next day brought the Big Event. Young and old gathered at the waters edge to see the Big Man with the Little Airplane and the Electric Box do his stuff. The motor screamed to life after only an hours coaxing . . . nothing like fresh fuel ... all controls tested . . . the ship roared out in the lake, made a half circle . . . screamed toward the shore and drove ten feet up on the sand . . . motor still revving . . . pick it up and head to sea again and a little quicker on the rudder, please. This time it made it half way across the lake before we gave up and agreed that it was not going to take off.

Hand launch ... at least I will have the thrill of seeing the gossamer feather of wake behind the pontoons as she eases onto the oil slick surface of the lake. Picture, if you will, a really large man dressed in a bathing suit called baggies, a model airplane in one hand and this electric box in the other, trying to pick up enough speed in about a foot and a half of water to get his plaything airborne. ...

Well, we finally made it and a mighty cheer went up from shore and pier. We flew down the shore line and back over the pier ... we looped . . . we rolled ... we flew nearly out of sight . . . and out over the middle of the lake we performed a Split-S and the wing parted...

. . . the wing panel started its slow, twisting descent as is the fashion of wing panels, and laughing children roared out in an outboard to be under the point of impact. The rest of the mess came down at terrific speed, and I nudged the throttle control to be sure it was peaking out. . . .

Considering how hard that water must feel from that height, it held together very well. But not so well that I could get very excited about repairs.

However, don't forget that within the next couple of years I'll be going back to Trout Lake and you'll all have a first hand report on how to do it. In the meantime, I suggest you turn your attention to other magazines where water and R/C do mix, and where the Editors are competent. . . .

See you next month.

# The Roostertail



The Official Publication of the International Model Power Boat Association General Office: 2405 19th Avenue Broadview, 111. 60155

## TWO NEW WORLD RECORDS

were established at the Minute Brakers 3rd Annual Regatta at Lombard, Illinois, July 24 and July 25. In the ¼ mile oval in the A-3 class a time of 1.44.4 was set by Scott Jordan. The A-3 class specifies an .09 engine in an unlimited hull, Scott has a little 26 inch original design powered by an OS Max .09. The radio was an Orbit.

The D-1 record was set by Frank Toth in the ¼ mile oval, at 0.52.9. Frank had a "Cobra" hull with a Torp 45 for power. The radio was an Orbit. Frank didn't fare quite as well in the multi boat race and dumped the Cobra twice. Frank used the heater in his car to dry out the receiver between heats. This might be worth remembering!

**EMBLEM CONTEST** — The supply of IMPBA decals is just about down to zero and instead of just re-ordering more of the same, I think it would be fitting if we could come up with a new design. The present emblem looks like so;



The background is kelly green, the boat and letters are mustard yellow, the world globe is white with black line work. The date "1949" is the date of origin of the IMPBA. What do you think the emblem should be?

What kind of an IMPBA decal would you like to display on your boat? What do you think would properly portray the new image of a progressive model power boat association which includes tether racing and R/C speed? Do you have any artistic talents? Do you think you have an idea and the talent to create a new emblem which will symbolize sportsmanship, craftsmanship and fellowship in international model boating? Send it in to the general office. The winner of this emblem contest will receive a free one year membership in the IMPBA and a one year subscription to the R/C Modeler. The board of directors will act as judges. Contest closes November 30, 1964.

**OCTURA TROPHIES**—Through the courtesy of Octura Models, 81441/2 Milwaukee, Niles, Ill. a set of 6 trophies has been donated for certain records that are first attained by entrants in a sanctioned regatta. The records to shoot for are as follows: 1/16 Mile Event:

Class C. .201-.300 Cu. Inch—30 MPH  
Class E. .459-.670 Cu. Inch—40 MPH  
Class F. .671-3.05 Cu. Inch—35 MPF [ 1/4 Mile Event:

Class C. .201-.300 Cu. Inch—45 Sec. Class E. .459-670 Cu. Inch—35 Sec. Class F. .671-3.05 Cu. Inch—40 Sec.

If you attain one of these speeds or times send us your record application and we will send you the Octura Hi-Speed Trophy. A tip of the IMPBA hat to Octura Models for their most generous offer. These trophies were on display at the Minute Brakers meet in Lombard, Illinois and at the Tri-City Radio Controllers regatta at

Beloit, Wisconsin. They sure are beauties and present a fine challenge.

**Here is an interesting** note from our Japanese friends. From Ken Arikawa of the Tokyo Model Boat Club the picture showing Ken's boat running half speed on Lake Yamanaka. Ken said they held their 3rd Annual Long Distance Contest at Lake Asi Hakone on May 12th and 13th. More than 30 boats from all parts of Japan joined in this competition. The course that is run is 12 km. Ken did not state if this was an oval, triangular, or what type of course this is. Here are some of the classes and times involved.

Class "A" (up to 10 cc)

A. Sato — 31 M—27.7 S.

Class "B" (up to 37 cc)

T. Koyam — 20 M—19.1 S.

Class "C" (up to 50 cc)

H. Toriyama — 24 M—16.0 S. The points of long run are endurance, reliability for R/C engine, and sailing of hull on rough open water surface. It sounds like an interesting time was had by all.



OFFICIAL U.S. NAVY PHOTOGRAPH

*Lt: Penny von Hekken, 1964's Miss Model Aviation. Lower  
lt: Bob Carlisle's scale DH-2. Below: Dale Nutter with  
record-breaking Sidewinder. Jerry Krause looks on. Lower  
rt: 2nd place Class III winner Zel Ritchie and Phantom  
with RCM's Chuck and Clare Waas.*

OFFICIAL U.S. NAVY PHOTOGRAPH

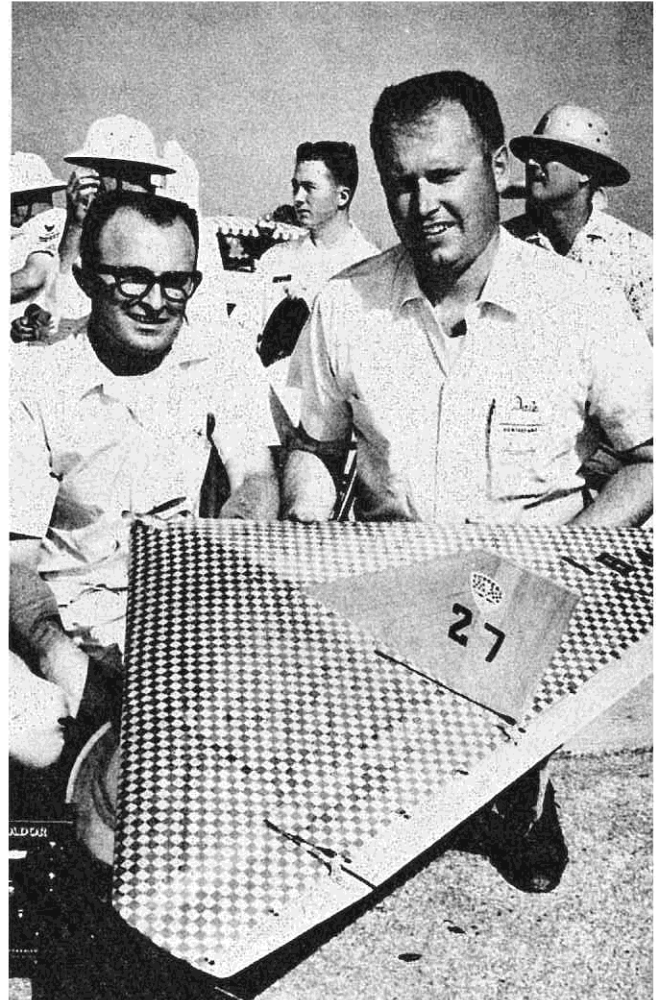

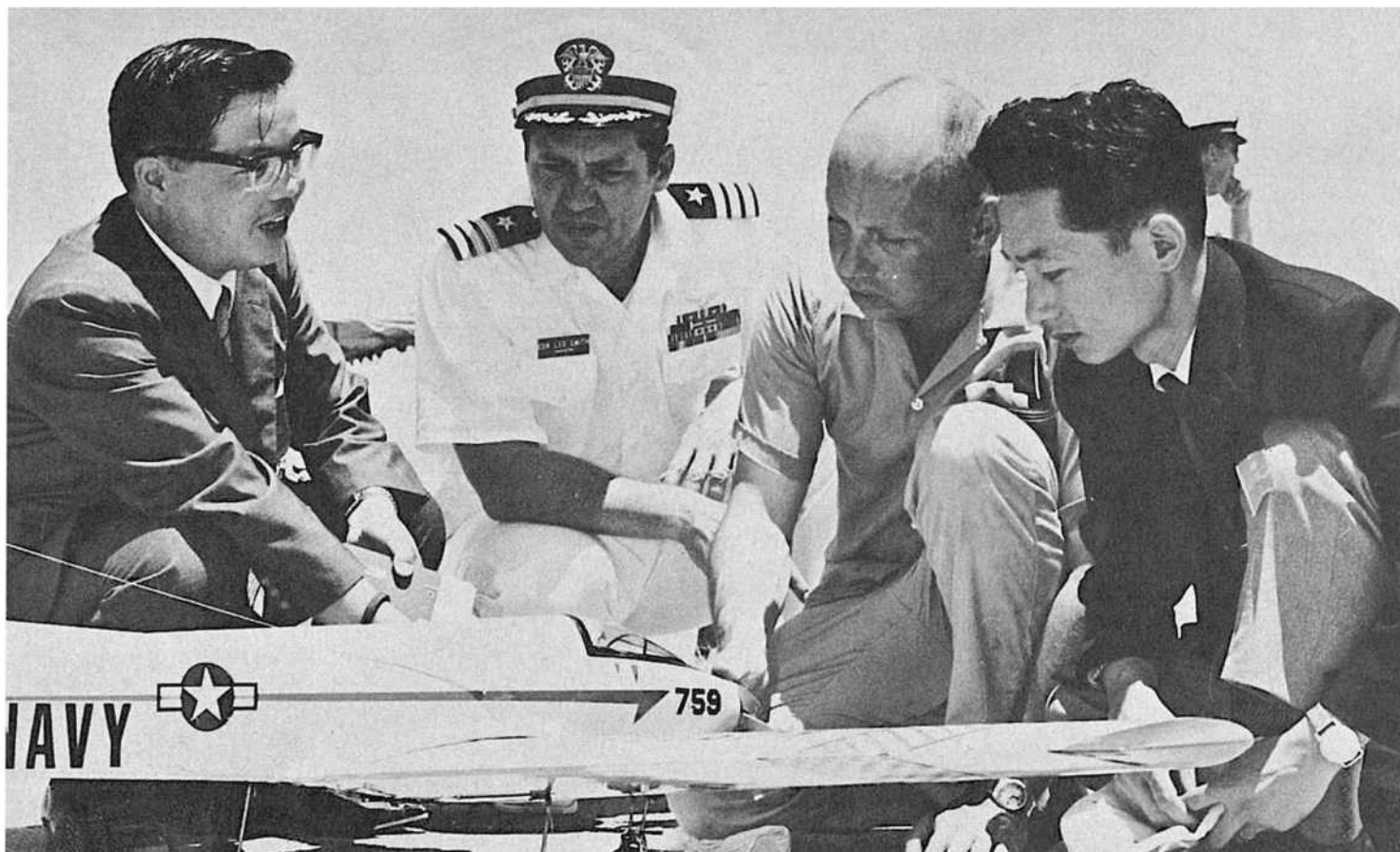

*L to R: Seiji Kosaka, Osaka, Japan; Commander Leo A. Smith, Model Meet Officer, U.S. Naval Air Station, Glenview, Illinois; Dr. Ralph Brooke, third place Class III winner, and Mr. Masahiro Kato, Osaka. Brooke's model is an original design, the Crusader.*

OFFICIAL U.S. NAVY PHOTOGRAPH

## Radio Control Championships

### 1964 Nationals

The 1964 version of the National Model Airplane Championships, held at the Dallas, Texas Naval Air Station, marked the 41st such event, and the 24th to be directed by the Academy of Model Aeronautics. Having grown from a single event drawing 27 contestants from six cities in 1923, to a 35 event program drawing over a thousand contestants from the 50 states and abroad, it is recognized as the world's largest and most varied model aircraft contest. This year, the Nationals drew an estimated 75- 100,000 spectators. The radio control championships, alone, had approximately 125 contestants. Reigning over

the 1964 affair as Miss Model Aviation, was eighteen year old professional model, Penny Van Hekken of Oak Cliff, Texas.

The schedule of events for the weeks activities included Pylon, Monday through Friday; Class I, II and III, Monday through Saturday; and R/C Scale, Saturday and Sunday. The first day's activities saw Oklahoma's Dale Nutter set a new pylon speed record with his famous Sidewinder— a time of 59.25 seconds, shattering his own world mark set recently at Bakersfield, California.

On Friday, young John Jennings established a Junior' Pylon time of

1:26.6, breaking the world's record he had set only a day or two before!

The prime interest in the RC events centered around Class III competition, and it can be said without fear of contradiction, that this year's contestants showed a caliber of performance that was without peer. Virtually every top multi flier in the country had entered the Nat's competition, and from day to day, it was anyone's meet. The deciding flight was made by Cliff Weirick and his Candy — in a 25 m.p.h. wind! Despite this handicap Weirick displayed a proficiency of flying that had to be seen to be believed!



Above: Beautiful scale Fokker; Above rt: Cessna Skymaster on the ready line; Rt: Maxey Hester's winning Pin Ball.



# SCALE

Scale, this year, was rather poorly attended, with only nine entries. Class I and II competition was of top caliber, but again, not too heavily attended.

What can definitely be said about the 1964 Nat's is that it was the most well-organized, efficiently conducted of all of these annual meets. The Academy of Model Aeronautics and the U.S. Navy have earned the gratitude of every person who participated or attended the Dallas activities. The entire program was a tribute to the people who were responsible for its existence.

A special vote of thanks is due to the Collins Radio Corporation of Dallas for their installation and operation of \$20,000 worth of monitoring equipment — simultaneously monitoring all R/C frequencies for the benefit of the entrants.

Another group of individuals who should, be remembered for their efforts is Squad 18 of the Amarillo Texas Air Explorer Scouts, along with their three advisors.

Among the many notables attending the Nat's was Mr. Masahiro Kato, Managing Director of the world famous Kato Model Aircraft Company, and holder, of the 1963 Japanese R/C Championship, whose visit, along with that of his public relations rep-

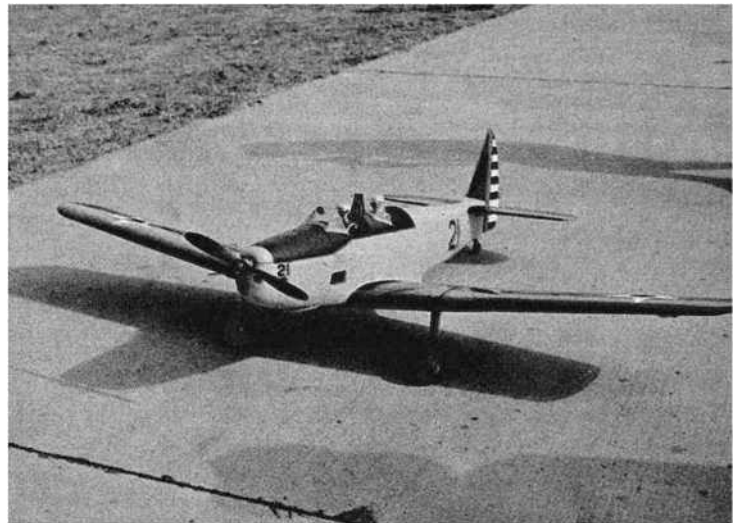

Above rt: An old favorite, the PT-19, third in Scale. Rt: Claude McCullough's unusual X7B2D-1 Skypirate.



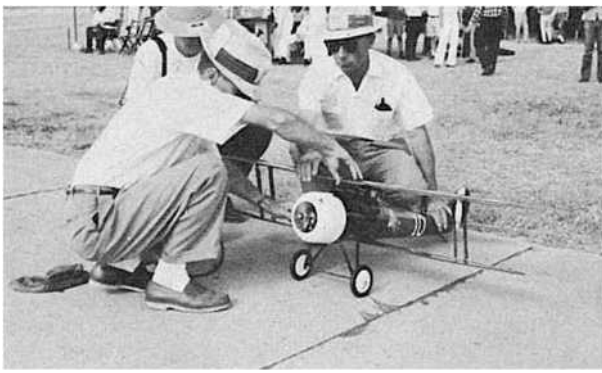

*The Williams brothers Nieuport 28. Best flying Nat's scale entry.*

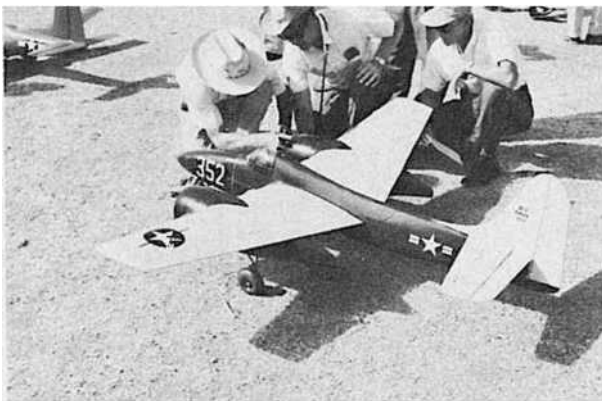
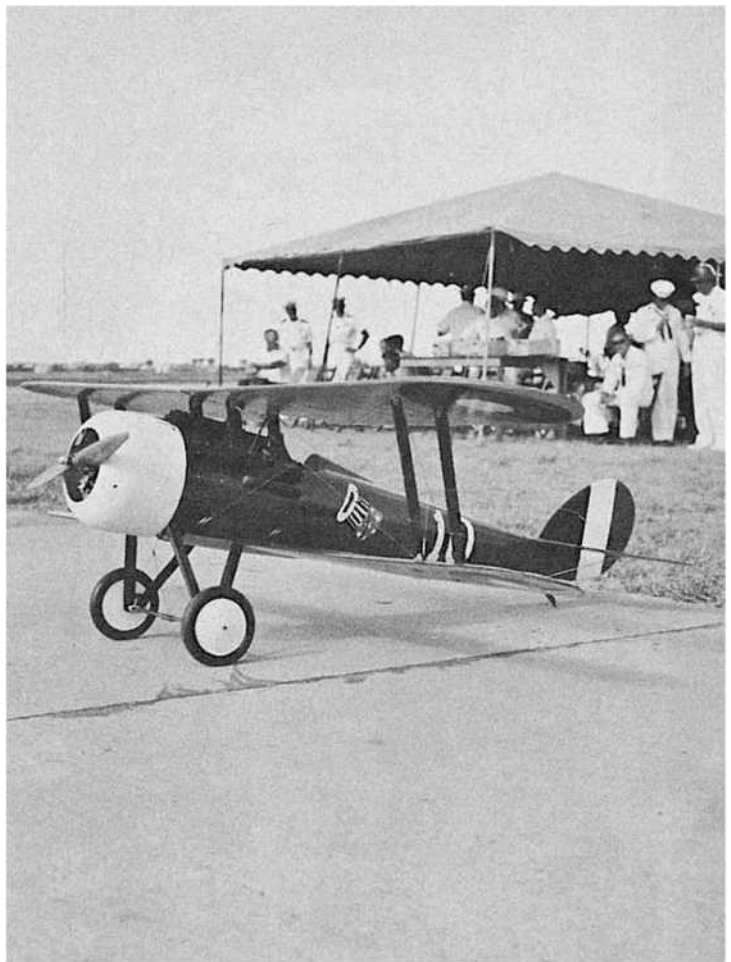
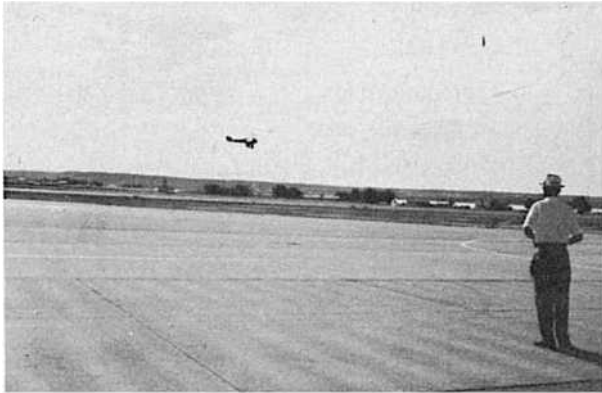

*Jerry Welborne's F7F-1 Tiger cat. 1200 inches of wing and two Super Tiger 46's.*



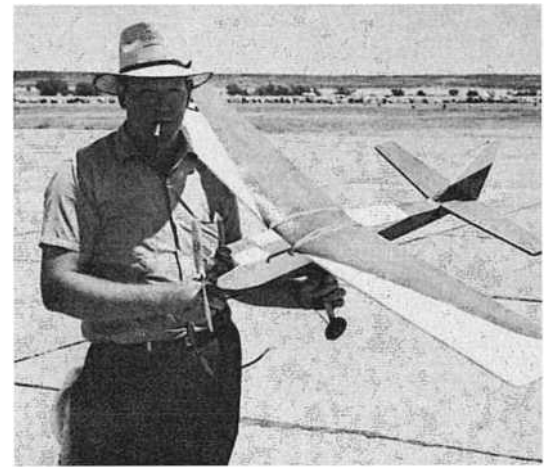
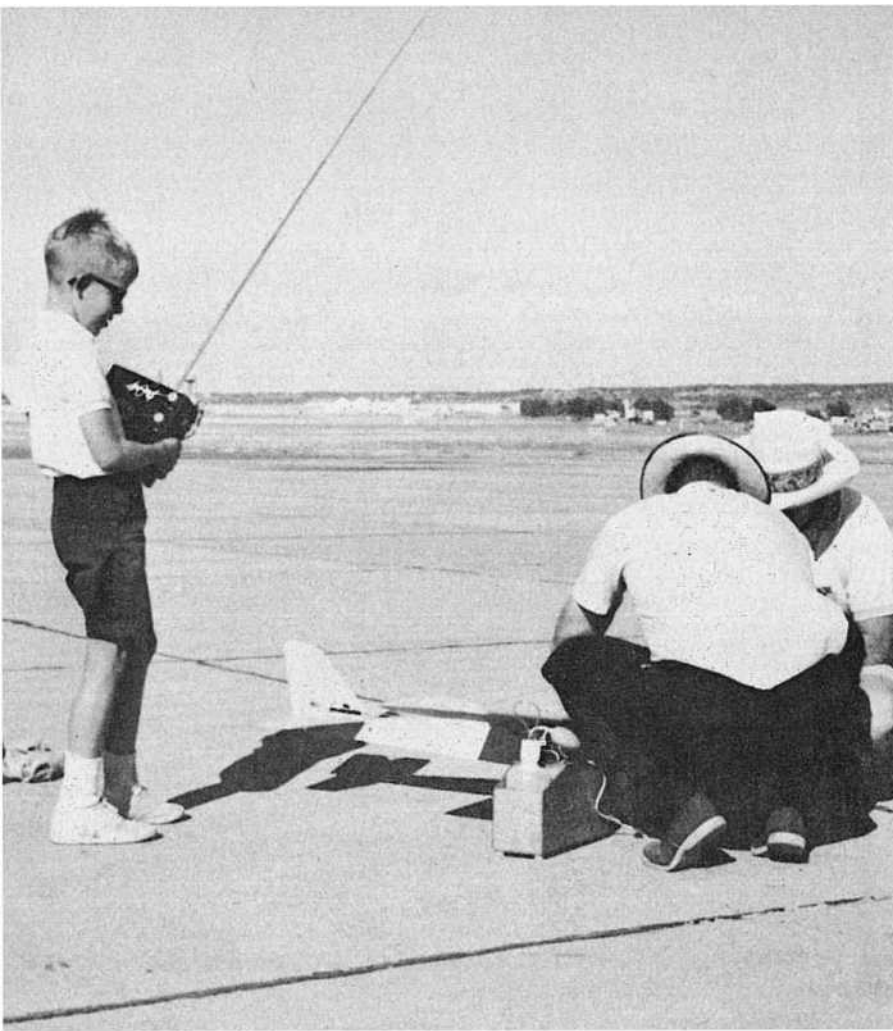

*Lt: 11-year old Bobby Woods, youngest RC contestant, readies his Jenny. Above: Tom Williams, Open Class 1 winner with his Skinny Jenny. Below It: John Slater, KCRC, and the Mark I. Below: Pete Petri, 2nd place and total high points winner with his original Air-Conditioned design.*

# CLASS I



representative, Mr. Seiji Kosaka, was arranged by the Royal Products Company of Denver.

As a finale to the 1964 Model Airplane Championships, an Open House, NASA Spacemobile demonstration, and Air Show was held aboard the Dallas NAS. Bill Fornoff, a former naval aviator, flew his F8F Bearcat and P51 Mustang through precision maneuvers that held the spectators spellbound. The Starflights, a navy precision tumbling team was on hand to demonstrate their split-timing maneuvers. The U.S. Army's free-falling parachute team, the Golden Knights, presented a colorful aerial spectacle as they performed their skydiving maneuvers trailing colorful smoke through the air. Leaping from their aircraft at over 13,000 feet, the nine-man team from Ft. Bragg demonstrated individual maneuvers, two-man acrobatics, and a final four-man formation, during four 75 second free-falls.

Presentation of the Championship awards in all classes, plus the performance of the U.S. Navy Band from Pensacola Naval Air Station highlighted Sunday's activities and marked the final day of the 1964 Nationals.

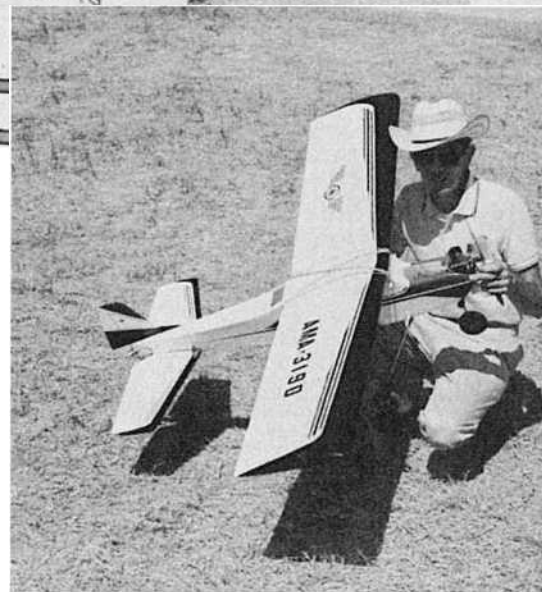

*Above rt: A nice departure from conventional Class I designs—Gordon & George's Sigma Seven. Above: Mel Santnyers' ST 46 powered original. Left: Steven Stong's original entry in Junior-Senior.*



*Rt: Ron Chapman's Golden Norseman II. Lower rt: Maxey Hester's Straturs. Below: Doug Spreng's Kwik-Fli. Lower It: Another Kwik-Fli—Phil Kraft and 4th place winning entry. Extreme lower rt: Chicago's Les Fruh and Taurus II.*



# CLASS II & III

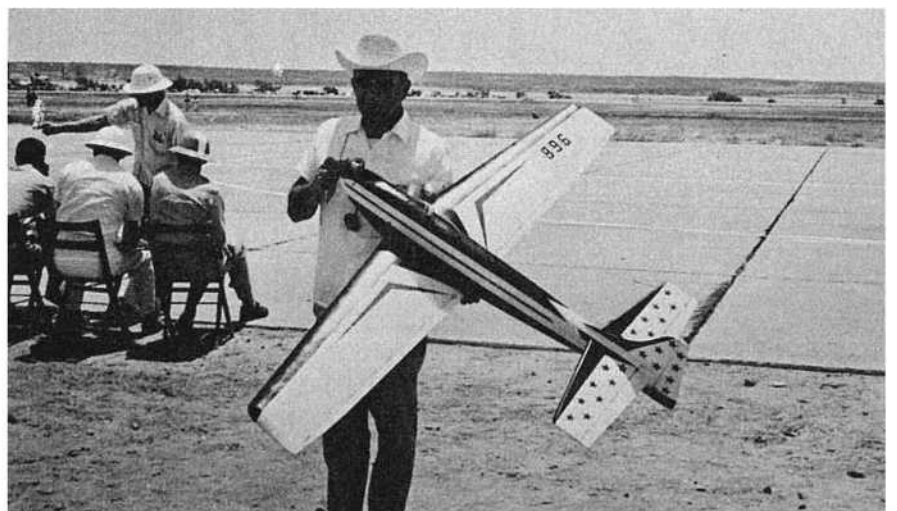

*Below: W. A. Kriost, Tulsa Glue Dobbers and his Astro Cat. Servo elevator, pulse rudder. Lower It: 3rd place Class II winner, David Burt and original Deadbeat.*

*Below: Willie Smith's Torero with Digimite proportion, Below rt: Darryl Usher and original F-10, Kraft proportional. Lower rt: Custom engine man .41 Jekel and modified Taurus.*

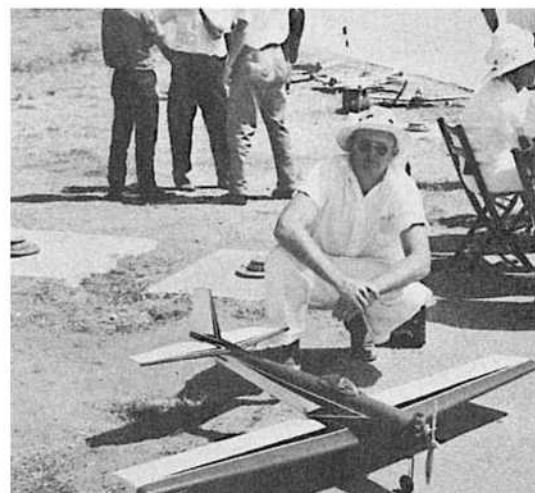
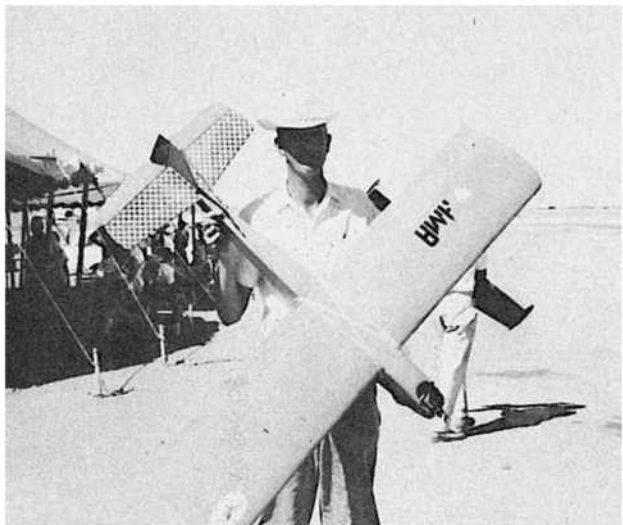



## A New Record . . . .

*John Jennings of Dallas, Texas, seen with his record-breaking entry, a stock Midwest Hustler delta. Super Tigre .15, F & M Hercules and Midas. New Junior pylon time of 1:26.6.*



## . . . . And An Old Story

*It's part of the game—picking up the pieces and managing a smile for the photographers. The Williams Brothers with the end of a fine ship ... and the conclusion of RCM's photo coverage of the 1964 Dallas Nationals.*

# 1964 Nationals

## Radio Control Championships

### Data Sheets

The information contained in the following pages was obtained from RCM's individual data sheets, completed by approximately 96% of the R/C contestants at the 1964 Dallas Nationals. While every attempt is made toward accuracy, some discrepancies are bound to occur in the data listed.

As interesting indicators of possible trends in the radio control field, the following information was tabulated from this material:

The average contestant was 33.4 years of age with 7.5 years of experience in RC. The average winner in all classes was 35.2 years old with a one and a half year edge in experience. Of the ships entered, 43% were original designs, 30% built from magazine plans, and 27% stock or modified kits. Among the winners in all classes, 72% were original designs, 24% from magazine plans, and 4% modified or stock kits.

In the power category, the Veco .45 was again the majority favorite, although losing considerable ground from last year's Nat's to the increasing popularity of the bigger mills. 36% of the overall entrants used the Veco with 14% favoring the Super Tigre .56 and 9% the Fox .59. The balance of the percentage was distributed among a variety of power plants, with the Super Tigre line the overall favorite. No engine pattern was evidenced in Class I or II, but it is interesting to note that the larger mills swept Class III completely, with the ST .56 and .60 sharing the honors with the big Fox .59.

In the fuel department, last year's overall favorite, K&B 100 retained its popularity, but suffered a substantial drop percentage-wise as 20% of the contestants used homebrew fuel. The K&B mixture totaled an additional 40%. Among the winners, 63% used K&B 100, 21% homebrew, and the balance a variety of makes.

Insofar as finish is concerned, the expected trend toward epoxy finishes was not evidenced as 80% of the entrants showed a preference for butyrate dope, the overall nod going to Aero Gloss. 15% used epoxy, or a combination of butyrate-epoxy, Hobby Poxy being the favorite in this classification. The remaining 5% chose a lacquer type finish.

In the highly competitive, and all-important, equipment classification, it was quite apparent that proportional gear made its mark. 39% of all contestants used proportional radio equipment representing nine different manufacturers and one home-built rig. 52% of the proportional systems entered were manufactured by Orbit Electronics, the remaining percentage spread between Bonner, Kraft, Dee Bee, Klinetronics, Sampey, F&M, Digicon, and Elltronic. Among the winners in all classes combined, 34% used proportional equipment and 66% reed gear. Among the Class III winners, all of the first five positions were taken by feedback systems — 1 Bonner, 2 Orbit, and 2 Kraft. Of the reed equipment used, comprising 61% of the overall entries, Orbit was by far the favorite with a 51% margin. Min-X and F&M were second and third, respectively, in popularity. Among the winners using reed equipment in all categories, Orbit and Min-X were about equal.

A trend or two from this year's Nationals? They're quite apparent — read the data sheets for yourselves and form your own conclusions.

Code: Plane, Source: (O), Original; (P), Plans; AM, American Modeler; MAN, Model Airplane News; RCM, R/C Modeler; RCME, Radio Control Models & Electronics; (SK), Standard Kit; (MK), Modified Kit. Controls: R, Rudder; E, Elevator; M, Motor; A, Aileron; T, Trim; F, Flaps; L, Lights; BD; Bomb Drop; PE, Pilot Eject; LAH, Lower Arresting Hook.

Name R/C Club City, State	Age; Yrs. in R/C	Class Place	Plane Source	Span Area	Weight Lb/Oz	Engine Fuel, Prop'	Finish	Controls	Receiver Transmitter
Robert Angus Tucson, Arizona		1 5th							
James Beason Alexandria, La.		Pylon 5th							
Rogers L. Barton Corpus Christi, Tex.	45 12	1	Zeus 'Mk 11 (O)	60 560	5-8	Veco 35 Missile Mist Torn 10/6	Butyrate Epoxy	RM Ancco	Orbit 12 Orbit 12
Richard Bereman WRCC Wichita, Kansas	21 2	3	Taurus (MK)	70 720	6-2	Veco 45 KB 100 Revilp 11/6	Butyrate	REMAT Bonner	Orbit
Bill Blackford TORKS Oklahoma City, Okla.	16 2	2	Falcon (MKJ)	49 490	3-11	Veco 19 Missile Mist Torn 9/4	Butyrate	Ancco Hillcrest	Controaire

Name R/C Club City, State	Age; Yrs. Class in R/C Place	Plane Source	Span Area	Weight Lb/Oz	Engine Fuel Prop	Finish	Controls	Receiver Transmitter
Max Boal KCRC Kansas City, Mo.	17 2	TAT-2 (O)	56 672	5-12	Veco 45 Tornado KB 100	Epoxy	REM	Orbit
Ken Boyd Golden Triangle Arlington, Texas	40 8 3	Sweeper (O)	58 730	6-10	Fox 59 KB 100 RevUp 12/6	Butyrate	REMAT Proportional	Proportional
Chuck Boyer LARKS Hawthorne, Calif.	29 9 3	Trashle (O)	70 756	6-4	Lee 45 KB 100 Top Flite 11/6	Butyrate	REMATF	Orbit 12 Orbit 12
Henry Brazin R/C Club of Chicago Chicago, Illinois	39 10 3	Taurus (MK)	65	6-0	Veco 45 Own fuel Top Flite 11/7	Butyrate	REMAT	Orbit 10
Philip Breittling LARKS Torrence, Calif.	44 12 3	Pallie (O)	66 700	6-5	Veco 45 KB 100 11/6	Butyrate	REMAT	Orbit 10 Orbit 10
Jimmie Brittan Springfield R/C Club Springfield, Mo.	34 4 3	Taurus (SK)	70	6-10	Veco 45 KB 100 Tornado 11/6	Butyrate	REMAT	Orbit 10
Dr. Ralph Brooke RAMS Seattle, Washington	34 8 3rd	Crusader (O)	69 700	7-2	ST 60 KB 100 Top Flite 11-7	Butyrate	REMAT Proportional	Proportional
Cletus Brow HARKS Hobbs, N.M.	30 4 2 5th	Original	64 740	5-4	Veco 35 Missile Mist RevUp 10/6	Butyrate	RET (RG) Bonner	CG CG
Don Brown West Jersey RC Club Woodbury, New Jersey	38 12 3	Taurus (SK)	72 720		Fox 59 KB 100 Tornado 12/6	Butyrate	REMAT Proportional	Dee Bee
Charles Brunner Signal Chasers Arnold, Mo.	27 4 3	Original	68 650	6-5	ST 60 Own fuel Top Flite 12/6	Acrylic lacquer	REMAT Bonner	Controlaire 10
David Burt Chicagoland RCM Evanston, Illinois	37 15 2 3rd HTP	Deadbeat (O)	56 645	5-5	ST 46 Own fuel Tornado 11/6	Butyrate	REM Proportional	Proportional
Jack Butler Salt Lake City, Utah	39 5 3	Expresso CO)	66 640	6-1	Lee 45 KB 100 Top Flite 11/6	Butyrate	REMAT Proportional	Proportional
John E. Carden Atlanta RC Club Forest Park, Ga.	29 3 3	Sultan (P) AM	64 700	6-8	Veco 45 Own fuel Top Flite 11/6	Butyrate	REMAT Proportional	Proportional
Robert Carlisle Norfalcons Norfolk, Neb.	43 8 Scale	DH-2	60 1200	7-8	Kyowa 45 Own fuel Grish 10/6 P	Butyrate	REMT Bonner	Orbit 10 Orbit 10
Ron Chapman Toronto RC Club Toronto, Ontario	34 6 3	Norseman II (O) RCM	62 620	6-8	ST 56 KB 100 RevUp 12/6	Epoxy	REMAT Proportional	Proportional
J. R. Cox ARKS Hobbs, N.M.	36 3 2	Original	62 712	5-5	ST 46 Missile Mist RevUp 11/7	Lucite	REM Proportional	F & M Proportional
Bud Crane EBRC Livermore, Calif.	39 6 3	Beatnick Bandit 78 (P) RCM	870	7-2	ST 56 KB 100 Tornado 11/6	Butyrate	REMAT	Orbit 12 Orbit 12
Don Crow LARKS/RCLOC San Clemente, Calif.	30 6 2 2nd BSF	Witchkraft (O)	56 616	6-0	KB 45 KB 100 X-Port 10/7		REMT	
Gory Davis DCRC Hyattsville, Md.	17 6 1-JS 2nd HTP	Sivad (O)	32 390	4-0	Merco 35 KB 100 9/6 3-blade	Butyrate	RM Mighty Midget	Own Own
Malcom Davis Valley Filers Woodland Hills, Calif.	42 9 3	Beachcomber IMP) MAN		9-4	ST 56 Fox Signal Top Flite 11/8	Butyrate	REMATF (RG) Proportional	Bonner Proportional
John W. Doy Cincinnati Aeromodelers Cincinnati, Ohio	30 5 3	Taurus ISK)	70 720	5-8	Veco 45 Testors 39 12/4	Butyrate	RMAT Bonner	
Harold deBolt Flying Bisons Cheektowaga, N.Y.	45 13 3	Interceptor (P) MAN	68 750	6-4	Merco 49 KB 100 RevUp 11/7	Epoxy	REMAT (RG) Proportional	Proportional
G. L. DeHaes Irving, Texas	40 12 3	Original	64	6-3	Veco 45 KB Hi-Lo RevUp 11/6	Butyrate	REMAT Bonner	F & M F & M
Curt Dim berg Chicagoland RCM Palatine, Illinois	36 6 3	Original	66	5-10	ST 56 Own fuel Top Flite 11/8	Butyrate	REMAT Bonner	Orbit 10 Orbit 10
Robert A. Doell LARKS Carpinteria, Calif.	39 6 3	Kwik-Fli IMP) RCM		7-12	ST 56 KB 100 Top Flite 11/8	Butyrate	REMAT Proportional	
Don Downing Flight Kings Wichita Falls, Texas	21 6 3	Original	64 680	6-2	Veco 45 Own fuel RevUp 11/6	Butyrate	REMAT	

Name R/C Club City, State	Age; Yrs. in R/C	Class Place	Plane Source	Span Area	Weight Lb/Oz	Engine Fuel Prop	Finish	Controls	Receiver Transmitter
Don Downing Flight Kings Wichita Falls, Texas	21 6	Pylon	Sidewinder (MP) MAN	34 570	2-10	ST 15 Own fuel RevUp 7/6	Epoxy	EA Annco	Orbit
Rav Downs LARKS Los Angeles, Calif.	46 15	3	Radiant (O)	64	7-0	Lee 45 KB 100 Top Flite 11/6	Butyrate	REMAT Proportional	Orbit Proportional
Dr. James Edwards Memphis R/C Club New Albany, Miss.	37 0	3	Taurus <K)	70	7-4	Veco 45 KB 100 RevUp 11/6	Butyrate	REMAT Bonner	Kraft 10 Kraft 10
William J. Eich JEFCO ARC Golden, Colorado	34 4	3	Candy (MP) RCM	70 740	6-8	Veco 45 Own fuel Tornado 11/6	Butyrate	REMAT Proportional	F & M Proportional
James Fielding Champaign Co. RC Club Champaign, Illinois	42 7	3	Hammerhead (O)	65 693	7-4	Fox 59 KB 100 Top Flite 12/6	Epoxy	REMAT Bonner	Orbit 10 Orbit 10
Maurice Franklin Westminster, Calif.	37 10	3	Skyghost	68 725	6-8	ST 60 KB 100 Top Flite 12/6	Butyrate	REMAT Proportional	Orbit Proportional
Ies Fruh Chicogoland RCM Evanston, Illinois	39 7	3	Taurus II (O)	68	6-4	ST 56 Own fuel Top Flite 11/8	Butyrate	REMAT Proportional	Orbit Proportional
Gordon A. Gabbert Dallas RC Club Dallas, Texas	45 20	3	Jet Fire (O)	72 880	7-0	ST 60 KB 100 Top Flite 12/5	Butyrate	REMAT Proportional	Orbit Proportional
Jackie Gardner Jackson, Miss.		1 4th							
Harold Goldkbank Penn. Ave RC Club Brooklyn, N.Y.	41 7	3	Stormer (P) AM	70	7-5	Veco 45 Testor 39 Top Flite 11/5	Butyrate	REMATB Bonner	Orbit 10 Orbit 10
George D. Gordon Toledo, Ohio	29 5	1	Sigmo Seven (O)	54	5-4	ST Piston Power RevUp	Butyrate	RM Bonner	F & M F & M
James Grier Chicago, Illinois	33 17	3	X-2 (O)	68 680	6-12	Fox 59 Neotane Top Flite 11/6	Butyrate	REMAT Proportional	Orbit Proportional
Richard Hanten Cozed, Nebraska	32 9	1	LW Cruiser (K>	55 775	6-0	Veco 45 KB 100 Top Flite 11/6	Butyrate	RM Bonner	Controlaire F & M
Elmer Helfert Chicogoland RCM Chicago, Illinois	30 9	3	Taurus (SK)	70 720	7-0	Veco 45 KB 100 11/6	Butyrate	REMAT Bonner	Orbit Orbit
R. T. Herndon Hamilton, Texas	37 1	Pylon	Duckhawk (SK)		4-0	Cox TD 15 Supersonic 100 Top Flite	Butyrate	CARM Bonner	Orbit Orbit
Robert Angus Tucson, Arizona		1 5th							
George H. Hill Hobbs ARKS Hobbs, N.M.	34 11	3	Taurus (MK)	66 660	7-0	Veco 45 KB 100 RevUp 11/6	Butyrate	REMAT Proportional	F & M Proportional
William L. Hiller Palos Park RC Club Ook Lawn, Illinois	38 3	3	Zeus	72 720	6-12	ST 56 Supersonic 100 11/6	Butyrate	REMAT Bonner	Orbit 10 Orbit 10
Tom Hinez Wichita R/C Club Wichita, Kansas	15 1	3	Sultan (MP) AM	60 720	5-8	Veco 45 KB 100 RevUp 11/6	Butyrate	REMAT Bonner	Orbit 10 Orbit 10
Bates Hunt, Jr. Pancake Modelers Iberal, Kansas	39 1	3	Taurus (MK)	68 720	6-8	KB 45 Fox Superfuel Tornado 11/6	Butyrate	REMAT Bonner	F & M F & M
Al Jekel Austin RCA Austin, Texas	32 3	3	Taurus (MK)	68 720		Trophy 45 KB 100 Tornado 11/6	Butyrate	REMAT Bonner	Orbit Orbit
John Jennings Palos RC Club Dallas, Texas	12 3	Pylon	Hustler (K)	44	4-4	ST 15 KB Speed RevUp 7/4	Epoxy	EA Annco	F & M F & M
John Jennings Dallas RC Club Dallas, Texas	12 3	3	Zeus	70 780	7-4	Veco 45 KB Hi Lo Top Flite 11/6	Epoxy	REMAT Bonner	F i. M F & M
Laurence P. Jensen Armstrong R/C Club Armstrong, Iowa	41 8	3	Taurus (MK)	68 720	6-8	Veco 45 KB 100 Top Flite 11/6	Butyrate	REMAT Bonner	Orbit 10 Orbit 10
Patterson Joyner Houston R/C Club Houston, Texas	34 2	3	Beachcomber (P) MAN	62 744	6-9	Veco 45 Testor 39 RevUp 11/6	Epoxy	REMAT Proportional	Digicon Proportional
Frank L. Kagele Costa Mesa, Calif.	28 4	Pylon	Sidewinder (P) MAN	44	2-14	Cox 15 KB 1000 Top Flite	Butyrate	EA Proportional	Bonner Proportional
Robert J. Kelly Mile Hi R/C Club Denver, Colorado	14 7	3	Jetfire (P) RCME	72	6-4	ST 60 KB 100 RevUp 11/6	Butyrate	REMAT Proportional	Orbit Proportional

Nome R/C Club City, State	In R/C Age; Yrs.	Place Class	Plane Source	Span Area	Weight Lb/Oz	Engine Fuel Prop	Finish	Controls	Receiver Transmitter
James Kirkland Guided Mites Valpariso, Fla.	39 10	3	Beachcomber (P) MAN	66 792	6-4		Epoxy	REMAT Proportional	Orbit Proportional
Jerry Kleinburg San Antonio MFI San Antonio, Texas	44 3	1	Separator (P) AM	48 380	4-12	Veco 35 Veco #1 Grish 11/4	Butyrate Epoxy	RM Bonner	C & S C & S
W. A. Knost Tulsa Glue Dobbers Tusa, Oklahoma	39 3	2 4th	Astro Cat (O)		6-8	Veco 45 KB 100 Tornado 11/6	Butyrate	REMT Bonner	Orbit Orbit
Phil Kraft Monterey Park, Cal.	38 5	3 4th	Kwik-Fli (P) RCM	66 800	6-12	ST 60 KB 100 RevUp 12/6	Butyrate	REMAT Proportional	Kraft Proportional
John H. Krauer Midwest RC Society Detroit, Michigan	37 5	Scale 4th	P-51			KB 45 Fox T2/6	Butyrate	REMAT Bonner	Min-X Min-X
John H. Krauer Midwest RC Society Detroit, Michigan	37 5	Pylon	Eclipse (O)			Cox 15 KB Racing 8/5	Butyrate	EA Bonner	Min-X Min-X
John If. Krauer Midwest RC Society Detroit, Michigan	37 5	3	Voltswagon (P)			Fox 35 Sig	Butyrate	REMAT Bonner	Min-X Min-X
Gerald E. Krause Tulsa Glue Dobbers Tulsa, Oklahoma	30 6	3	Copy-Kat (O)	64 800	6-5	Fox 59 Missile Mist Tornado 12/6	Butyrate	REMAT Proportional	Electronics Proportional
Milton A. Kruzich Lamar, Missouri	29 1	2	Aristo-Cat IP) MAN	63 724	7-6	OS Max 49 KB 100 Tornado 11/6	Epoxy	REMT Bonner	Orbit 10 Orbit 10
Austin Leftwich RCNC/Blue Mountain New Cumberland, Pa.	40 24	Pylon 2nd	Talon Zephyr IP) AM		2-7	KB 15 KB Racing Tornado	Butyrate	EA Proportional	Dee Bee Proportional
Austin Leftwich RCNC/Blue Mountain New Cumberland, Pa.	40 24	3	Original	70 810	6-0	Veco 45 KB 100 Tornado 11/6	Butyrate	REMAT Proportional	Dee Bee Proportional
Gary W. Leonard KCRC Kansas City, Mo.	20 4	1 1st-JS BSF	Mark 1 (PI RCM	64 720	6-0	Veco 45 KB 100 Tornado	Butyrate Epoxy	RM Bonner	Orbit 12 Orbit 12
Dr. Robert Lien Crescent City RC	37 12	3	Stormer (SK)	60 720	7-8	ST 56 Own fuel Top Flite 11/6	Butyrate	REMAT Steeb Prop.	Digicon Proportional
D. H. Lincoln Houston RC Club Belshire, Texas	30 7	3	Original	66 720	6-0	Veco 45 KB 100 11/6	Epoxy	REMAT Proportional	Digicon Proportional
Leonard McCoy KCRC Lamar, Mo.	34 14	2	Astro Cat (P) MAN	56 600	7-6	Veco 45 Own fuel Tornado 11/6	Butyrate	REMT Bonner	Orbit 10 Orbit 10
Claude McCullough Des Moines Modelaires Ottumwa, Iowa	42 18	Scale 5th	XTB2D-1 Skyirate	84 864	10-0	Fox 59 Own fuel Top Flite 12/5	Butyrate	REMATFL BD, TD, LAH Bonner	Min-X 12 Min-X 12
Dubby McGuire Hobbs ARKS Abilene, Texas	35 4	3	Taurus (SK)	70 720	6-9	Veco 45 Fox RevUp 11/6	Butyrate	REMAT Proportional	F & M Proportional
Jerry Nelson EBRC Livermore, Calif.	27 10	3	Patriot (P) RCM	66 720	6-4	ST 56 KB 100 12/6	Butyrate	REMAT Proportional	Orbit Proportional
Dale Nutter Tappers Tulsa, Oklahoma	29 10	Pylon 1st BTFA	Sidewinder (P) MAN	42 745	2-14	Leo 19 Fox Blast RevUp 8/6	Epoxy	EA Bonner	F & M F & M
Joseph C Parra LARKS Hermosa Beach, Cal.	33 6	3	Taurus (SK)	72 720	7-4	Veco 45 KB 100 Top Flite 11/6	Lacquer	REMAT Proportional	Orbit Proportional
James R. Pecot El Paso RC'ers El Paso, Texas	45 5	3	Candy (P) RCM	70 840	7-8	ST 56 KB 100 RevUp 11/7	Butyrate	REMATB Proportional	Orbit Proportional
H. C. Petri RAFB/MAC San Antonio, Texas	35 4	1 2nd HTP	Air-Conditioned (O)	48 384	4-3	McCoy 35 Hilo/Blue Blozcr	Butyrate	RM Bonner	CitizenShip CitizenShip
Dr. Pete Phillips Loke Charles, Ia.	35 9	3	Stormer (SK)	66 790	6-15	Fox 59 KB 100 12/6	Butyrate	REMAT Bonner	Orbit Orbit
Al Pinson Atlanta, Ga.	37 11	3	Sultan (P) AM	66 858	7-1	Veco 45 Own fuel Top Flite 11/5	Butyrate	REMAT Bonner	Kraft 10 Kraft 10
William Powell Omahawks RC Club Omaha, Nebraska	31 2	3	Orion (MK)	72	7-12	Veco 45 Own fuel Top Flite 11/6	Butyrate	REMAT Bonner	Orbit Orbit
Bill Prime LARKS Palos Verdes, Cal.	27 7	3	Taurus (SK)	70 720	6-0	Veco 45 KB 100 Top Flite 11/6	Butyrate	REMAT Bonner	Orbit Orbit



Nam* R/C Club City, State	Age; Yrs. In R/C	Class Place	Plane Source	Span Area	Weight Lb/Oz	Engine Fuel P op	Finish	Controls	Receiver Transmitter
Norman R. Rhodes Port Arthur 27 RC Club Groves, Texas	4	3	Taurus (SK)	70 720	6-5	Veco 45 KB HI Lo Top Flite 11/6	Butyrate	REMAT Bonner	Kraft 10 Kraft 10
Zel Ritchie LARKS Westminster, Col.	35 8	3 2nd	Phantom (P) RCM	66 800	8-0	Fox 59 KB 100 Tornado 12/6	Butyrate	REMATB Proportional	Orbit Proportional
Zel Ritchie LARKS Westminster, Cal.	35 8	Pylon 3rd	Diamond Back (O)	40 600	3-0	KB 15 KB Racing Top Flite 7/6	Butyrate	AE Proportional	Orbit Proportional
Howard E. Ritter RC Club Kalamazoo Gobles, Michigan	40 4	1	Tri-Squire (SK)	52 522	4-7	KB 19 KB HI-Lo Top Flite 9/6	Butyrate	RM Bonner	Min-X 10 Min-X 10
Michael A. Rittter RC Club Kalamazoo Gobles, Michigan	14 4	1 3rd-JS	Original	52 588	4-12	KB 19 KB HI Lo Top Flite 9/6	Butyrate	RM Bonner	Min-X 10 Min-X 10
Paul Ritter RC Club Kalamazoo Gobles, Michigan	17 3	1 5th-JS	Original	52 522	5-0	KB 35 Piston Power Tornado 10/6	Butyrate	RM Bonner	Min-X 10 Min-X 10
Lloyd Sager LARKS/RCLOC Riverside, Calif.	35 8	2 1st	Original	58 580	5-2	KB 35 Own fuel RevUp 10/6	Butyrate	REMT Proportional	Bonner Proportional
Mel Santmyers RC Club Detroit Warren, Michigan	5	1 3rd	Original	56 600	5-8	ST 46 KB 100 Tornado 11/6	Butyrate Lacquer	RM Bonner	Orbit Orbit
Walter R. Schoonard RCACF Winter Park, Fla.	39 15	3	Forerunner (O)	62 720	7-6	Butyrate	REMATF Proportional	Orbit Proportional	
Albin R. Signorino McDonnell ARC Club Bridgeton Ter., Mo.	29 5	2	Skylark (MK)	56 560	5-12	Veco 45 Own fuel Tornado 11/6	Butyrate	REMT Proportional	B & D Proportional
John C. Slater KCRC Kansas City, Mo.	36 2	1	Mark 1 (P) RCM	60 720	6-2	Veco 45 KB 100 Tornado 11/6	Butyrate	RM Bonner	Orbit 10 Orbit 10
Willie A. Smith LARKS Canoga Park, Cal.	47 8	3	Torero (P) RCM	70 910	7-0	ST 56 KB 100 Top Flite 11/7	Butyrate	REMAT Proportional	Bonner Proportional
Douglas C. Spreng Valley Flyers No. Hollywood, Cal.	32 12	3 HTP	Kwik Fil (P) RCM	66 792	7-0	ST 56 KB 100 RevUp 12/6	Butyrate	REMAT Proportional	Kraft Proportional
Stephen Strong Houston RC Club Houston, Texas	17 3	1 4th-JS	Original	55	5-1	Butyrate	RM Banner	Citizenship Citizenship	
Jack Strickland Houston RC Club Houston, Texas	31 7	3	Resistor (O)	61 794	6-0	Veco 45 KB 100 RevUp 11/6	Butyrate	REMAT Bonner	Deans Deans
Daniel D. Strong Midland, Texas	39 9	Scale 3rd	PT-19	72 920	10-0	Butyrate	REMATF Bonner Ancco	F & M F & M	
Donald Sump Sheridan, Wyoming	60 11	1	Krackerjack (SK)	53 475	5-10	Fox 59 Fox Signal Top Flite 13/5/1	Butyrate	RM Bonner	Orbit Orbit
William E. Thomas Bartlesville, Okla.	37 5	2	Aristo-Cat (MP) MAN	60 783	7-4	KB 35 KB 100 11/4	Epoxy	REMT Bonner	F & M 10 F&M 10
Jeffrey F. Thompson Crescent City RC Club Gretna, La.	32 8	3	Zeus-Taurus	70 720	7-0	Veco 45 KB 100 Tornado	Butyrate	REMAT Bonner	Orbit Orbit
Loren Tregellas WRCC Wichita, Kansas	29 4	Pylon 4th	Delta	41 585	2-7	Cox 15 KB Speed RevUp 7/6	Butyrate	EA Bonner	Orbit 10 Orbit 10
Darryl G. Usher Stardusters Portland, Oregon	29 10	3 5th	F10 (O)	66 670	7-4	ST 56 KB 100 Tornado 12/6	Butyrate	REMAT Proportional	Kraft Proportional
Ronald Van Beek RCLOC Redlands, Calif.	30 4	3	Original	72 700	6-8	Butyrate	Epoxy	REMAT Proportional	Orbit Proportional
Dan Watkins Norman, Oklahoma	42 10	Scale	PT-19	72 820	9-4	Fox 59 Missile Mist Top Flite 11-7	Butyrate	REMAT PE	Orbit Orbit
Clifford Weirick LARKS Point Mugu, Calif.	36 12	3 1st BSF	Candy (P) RCM	70 840	8-0	ST 60 KB 100 Top Flite 11/8	Butyrate	REMAT Proportional	Bonner Proportional
Jerry Weirick TORKS Oklahoma City, Okla.	35 5	Scale	F7F-1 Tigreat	80 1200	14-2	Butyrate	REMATFL RAH Bonner	F & M 12 F & M 12	
Larry Welliver Twin City RC Club Minneapolis, Minn.	18 10	3	Original	70	6-0	Veco 45 Own fuel Top Flite 11/6	lacquer	REMAT Proportional	Orbit Proportional

# THE KWIK-FLI

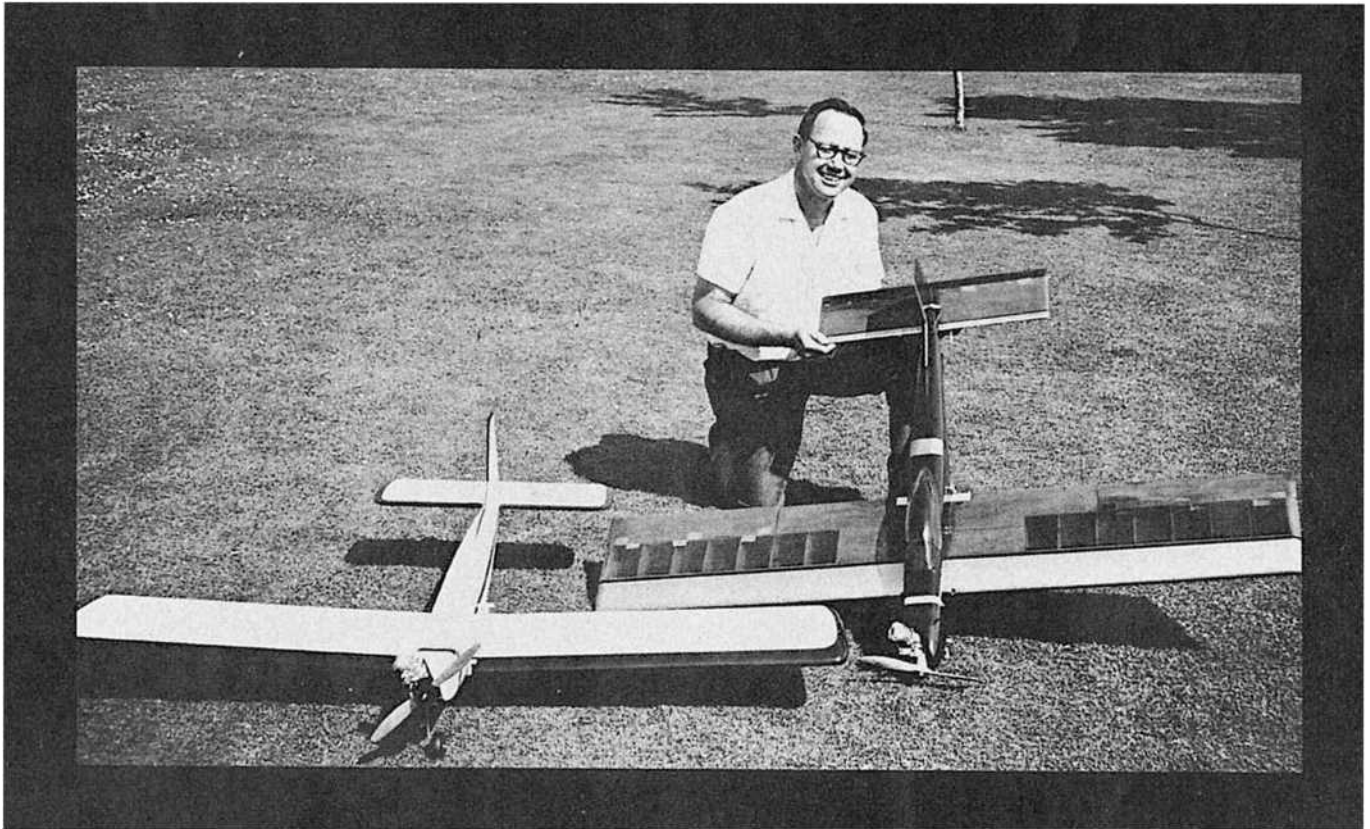

by Phil  
Kraft

**Phil's Fourth Place Nat's winning design has accumulated an enviable record of contest wins. For proportional or reeds, the Kwik-Fli is the end of the search for a ship that can be built in less than twenty-four hours, and with the consistent performance of an all-out contest machine. This is one for the hot pilot-and for bringing home the hardware.**



**One of the first prototypes — all white with black trim. Big mill sits at angle for proper fuel flow level. This is the design you'll see in the winners circle.**

Last Summer we became intrigued with the idea of developing a contest aircraft combining high performance with the fastest possible construction time. The construction design was also to feature inherently perfect alignment. After a month of head scratching and many sketches, the basic Kwik-Fli configuration evolved.

Aerodynamically, the ship was large with generous moments and stabilizer area. A thick, fully symmetrical airfoil, with sharply radiused leading edge was selected for its constant speed characteristics and superior stability over a wide range of attack angles. This airfoil section is largely responsible for the Kwik-Fli's superb landing characteristics and general flight "groovieness." The original prototype utilized a flat wing, sans dihedral, to speed construction. Except for appearance, we felt that dihedral was most unnecessary and probably detracted from the aircraft's overall performance.

The fuselage was designed so that it could be built from the top down, featuring a minimum number of parts. The entire fuselage may be completed, including mounting the stabilizer, servos, linkages, etc., while it is still pinned to the work bench and the glue drying. Wherever possible, standard wood sizes were selected, requiring very little cutting to shape. For example, the elevator was a piece of 2" x 1/4" x 24". The stabilizer consisted of two pieces of 1/16" x 6" x 24" built up over a Warren truss framework. The original fin was of 4" x 8" x 1/4" sheet. The radial mounted engine was positioned at an angle of approximately 30 degrees from horizontal to provide the proper fuel tank height in relation to the center of the engine's spraybar.

The first Kwik-Fli went together exactly as planned and with amazing speed. The fuselage structure proved not only to be very accurate and fast to build, but exceptionally light and strong. However, the airplane was, as expected, about as ugly as it was fast to build! The straight wing gave an impression of anhedral, while the overall effect of the airplane was that of a monstrous control liner with all-square surfaces! When first placed on the flight strip, the Kwik-Fli caused quite

a few raised eyebrows among the local flyers, while others practically rolled on the flight line with laughter. The comments came thick and fast—"Man, that airplane sure is tired . . . look at the wings droop . . . even the engine can't stand up straight!" "Hey, Phil — you forgot your control lines!" "Are you sure you've got the wheels on the right side?" etc., etc., etc. Doug Spreng's comment was that somebody finally developed an airplane uglier than the Stormer!

Inasmuch as we weren't too sure as to how much control movement would be necessary, we moved the linkages up to give more than the designed control throw. On the first takeoff, the Kwik-Fli went screaming down the runway — we eased back on the stick, it shot straight up, and we quickly found that we had too much throw on the elevator — the ship rolled so fast we practically lost count! Other than that the performance looked very promising. The ship was carted back to the shop, the wings opened up, and the aileron throw cut in half. The elevator linkage was also put back in the last hole where it belonged. We then returned to the local field where the troops were still laughing.

After the next flight, everyone stopped laughing. This ship was the best aircraft we ever had the opportunity of flying! It tracked through inside and outside loops with almost unbelievable precision and with no corrections necessary. The Kwik-Fli could be put into gentle turns either to the left or right without tightening to either direction, and its rolls were very axial. Landings, too, were beautiful — the ship could be brought in and slowed up until it reached a very high angle of attack, very similar to a Navy carrier type landing — rear wheels settling gently to the runway with the nose wheel holding two to three inches off until the ship slowed, followed by the nose wheel gently rocking forward on the runway.

Several hundred flights were racked up on this first Kwik-Fli before it met its demise in a mid-air collision. The second prototype followed, and was finished within five days after commencing construction. This ship was much lighter, weighing in at 6 pounds, and was subsequently

ered by a Veco .45. While it flew well enough, it was far below the standards of the heavier original with the Super Tigre .56. It was obvious that this size airplane needed to weigh approximately 7 pounds, and that even at 6 pounds, the Veco did little for the aircraft's performance. This prototype was flown for hundreds of flights until it became so moldy and oil-soaked that even we couldn't stand its appearance. It was decided that perhaps a little concession to appearance wouldn't add substantially to the building time, so we sanded down the Kwik-Fli, rounded the tips on the stab, and added a new and larger vertical fin. A new wing was constructed with just enough dihedral to take away the flat droopy appearance. The addition of these modifications, plus colored dope, brought the weight back up to 7 1/4 pounds and the Super Tigre was re-installed. The ship then flew in the same manner as the first prototype. While still no raving beauty, at least its appearance didn't make the spectators shudder!

The curious thing about the basic Kwik-Fli design is that every change we have made from the original configuration has detracted from its performance. A larger vertical fin did nothing for the aircraft, except perhaps, make it more difficult to spin. Even the slight dihedral sacrificed some of the axial qualities of the roll.

The dihedral did make the airplane slightly easier to fly and had less tendency to show up minor errors in wing attitude during loops, vertical eights, etc. Consequently, and except for appearance, the final version as shown in the plan, is very close to the original except for concessions toward a better appearance.

Construction accuracy is probably more important than minor design differences in the contest aircraft. Thus, the plane shows a built-up wing jig to insure that accuracy.

All of our flying with the Kwik-Fli has been done with proportional gear. However, several other Kwik-Fli's have been built utilizing reeds, and fly outstandingly well. The reed versions, however, have one-third of the elevator area removed and a longer horn ini' (Continued on page 28)

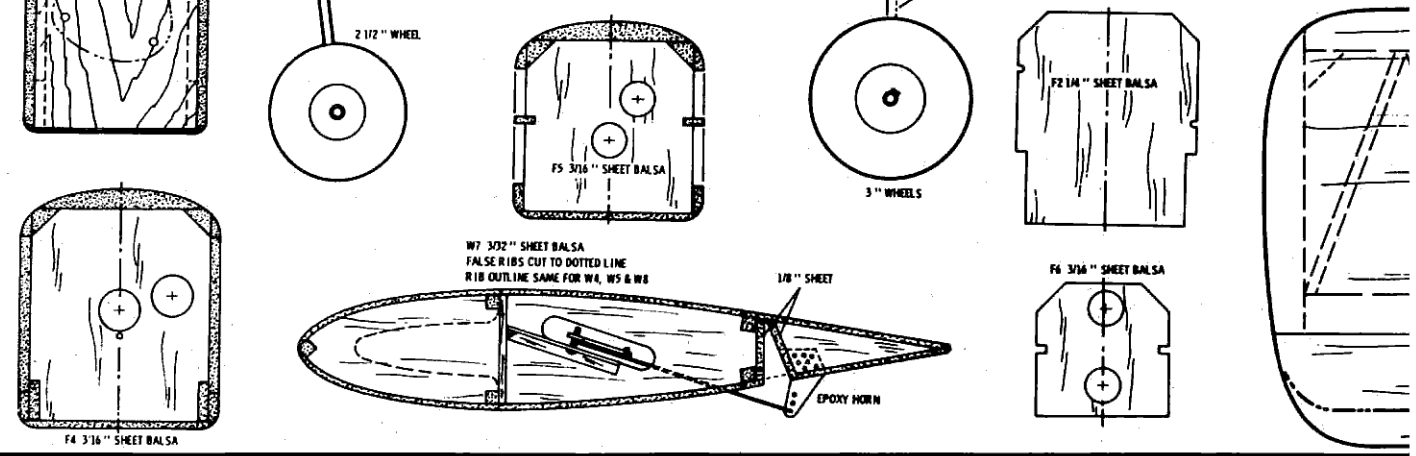
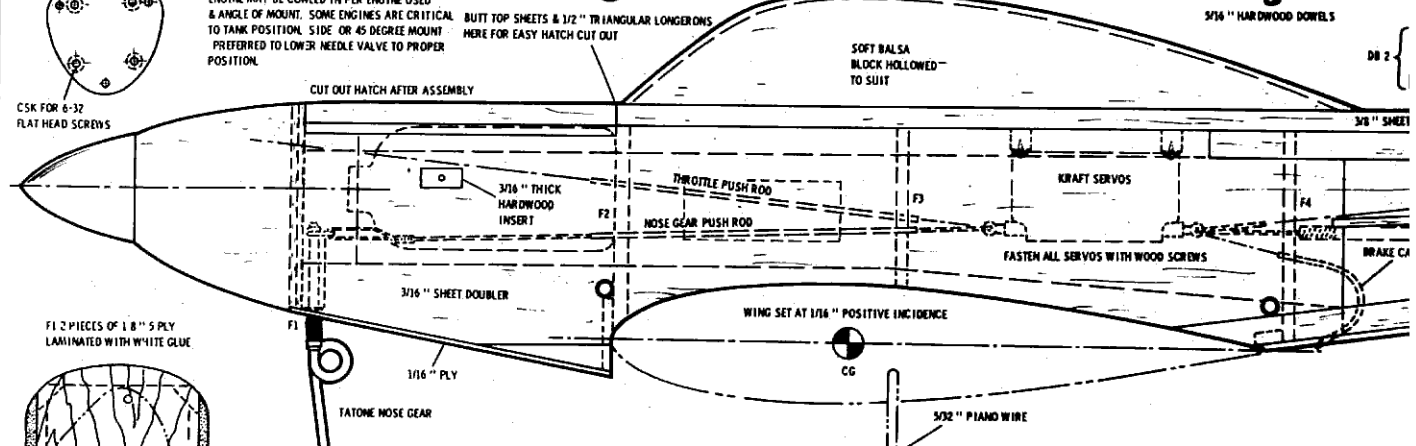
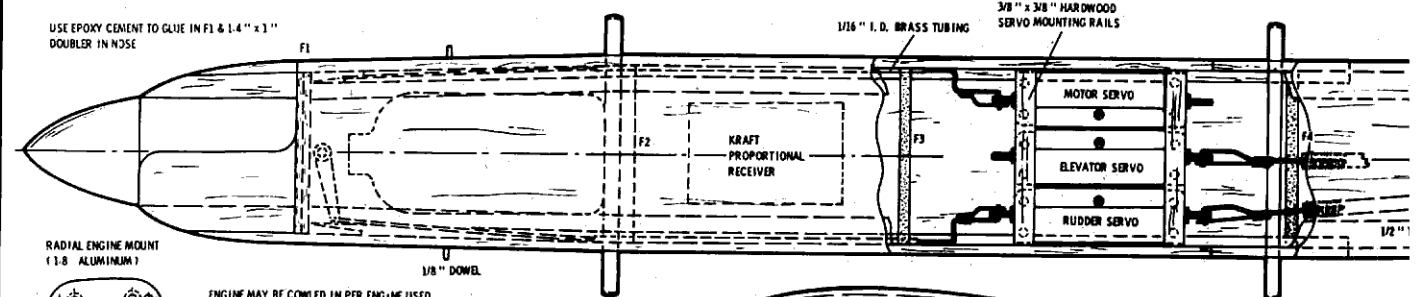
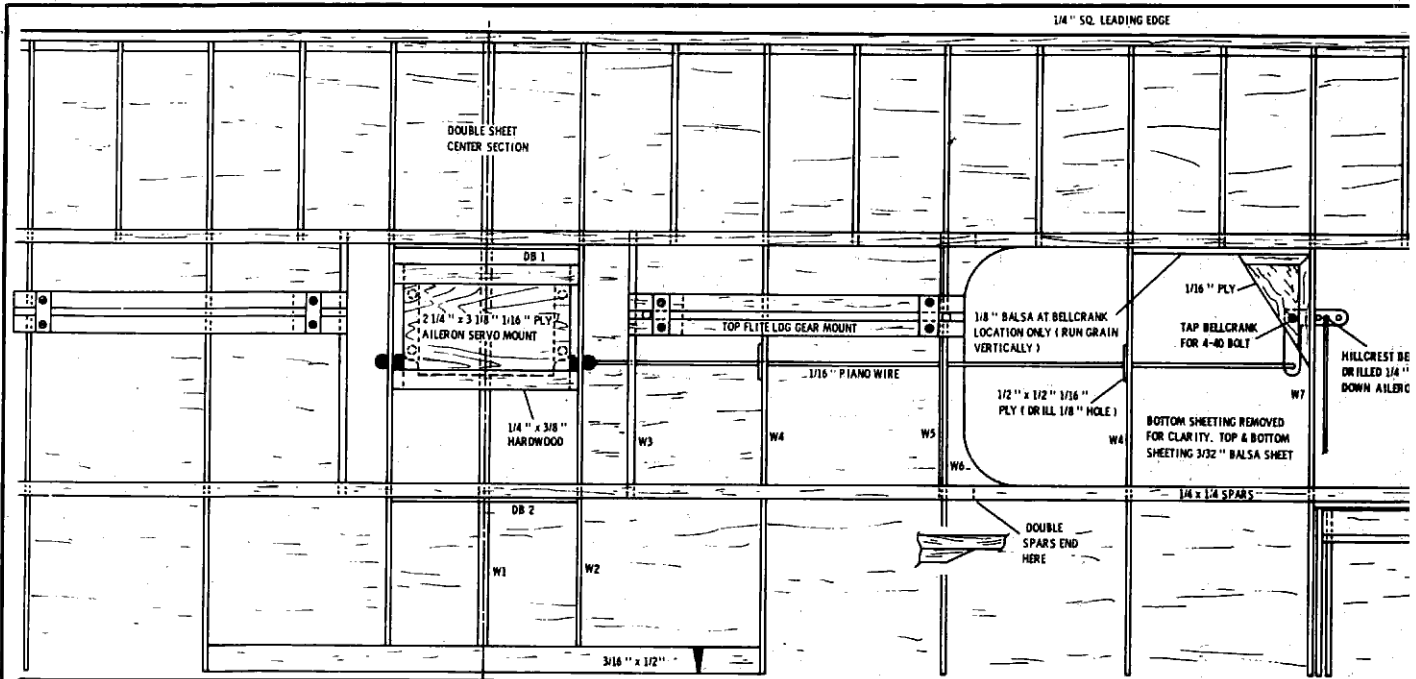

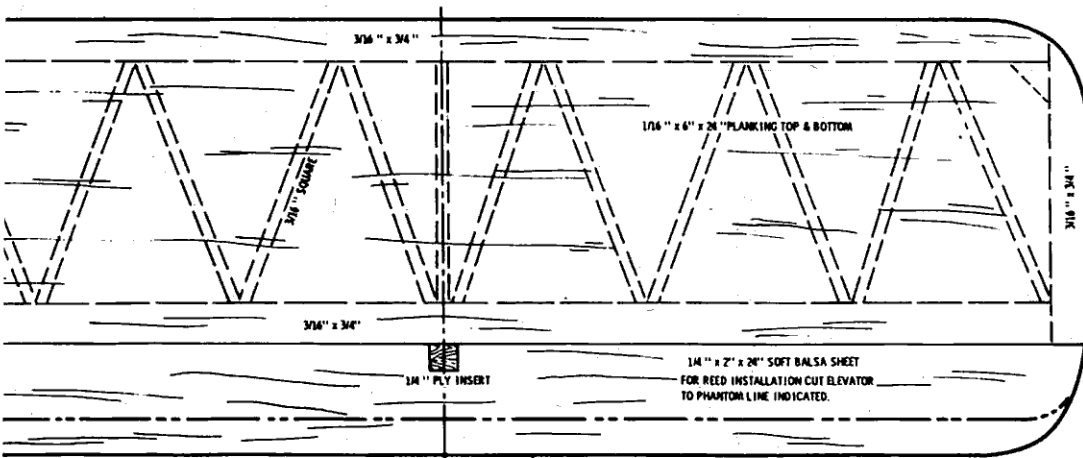
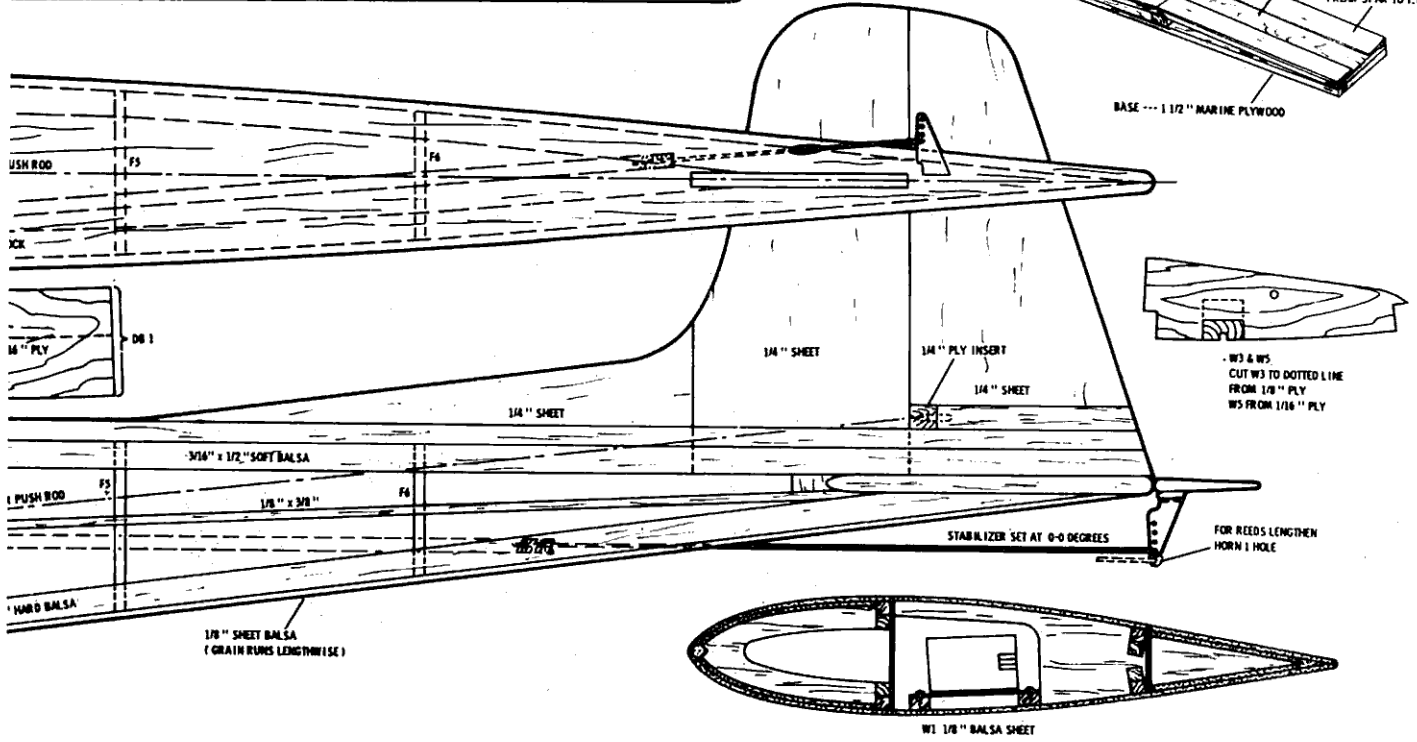
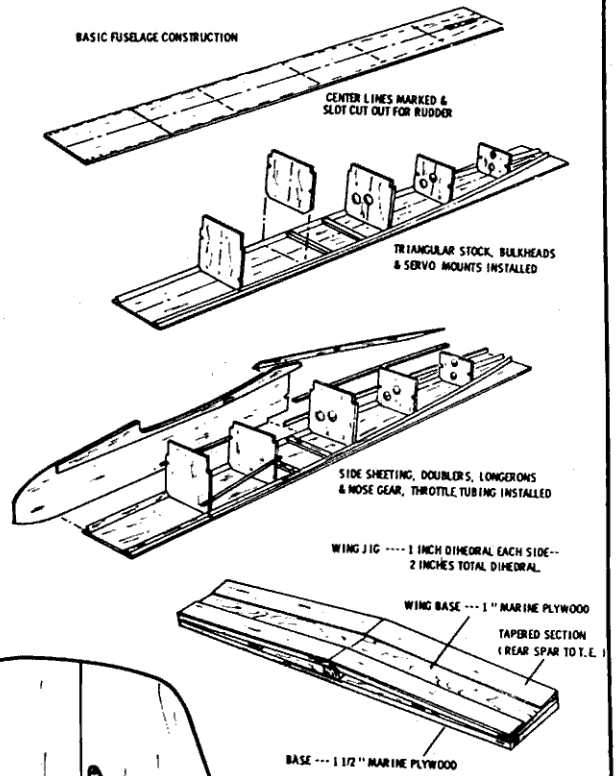
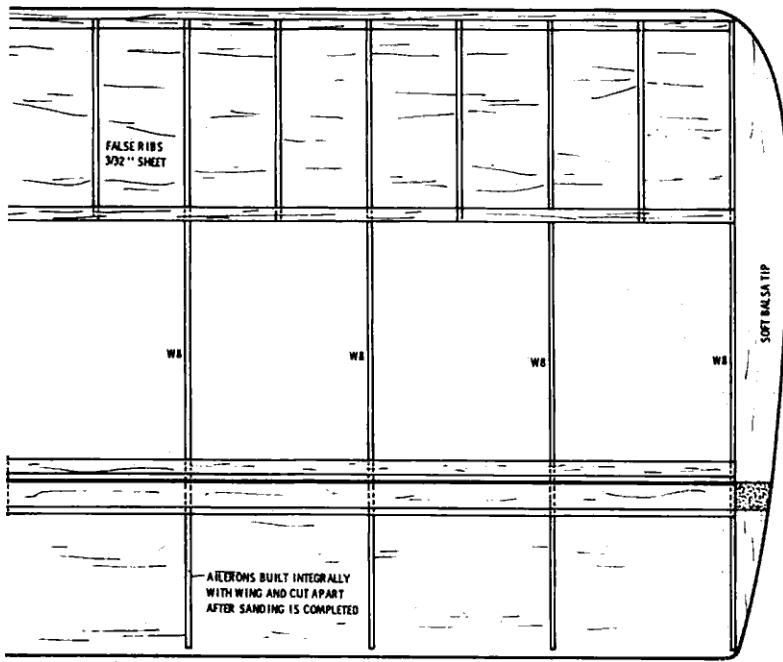

R/C modeler KWik Fli

DESIGNED BY PHIL BRADY DRAWN BY GEORGE A. WALKER

## KWIK-FLI

(Continued from, page 25)

stalled for smoother elevator response.

For contest performance, the Kwik-Fli does depend on large displacement engines, such as the Super Tigre .56 or .60. Unfortunately, the Super Tigre is notoriously unreliable in its standard configuration. However, some of the West Coast fliers, such as Cliff Weirick and Willie Smith, began modifying their Tigris with Johnson carburetors substituted for the standard plumber's nightmare, achieving excellent results. Adaptors were machined to properly fit the Johnson carb to the Super Tigre. Some also added an adjustable air bleed drilled into the adaptor just below the carburetor. This allows minor low speed adjustment to suit particular weather conditions. A spring must be installed in the Johnson unit to take out the slop in the mechanism which moves the needle valve in as the throttle is retarded. We understand that Super Tigre's latest model of the week will incorporate a throttle similar to this modification.

Because of the general unreliability of today's large engines (with the possible exception of certain of the modified Johnson carburetor Super Tigre's) we decided to build a smaller version of the Kwik-Fli. The fuselage is practically identical with the exception of the 1 1/2" shorter tail moment. The stabilizer and elevator are approximately the same except that they are now tapered. The wing has an 11" chord and 60" span for an area of 660 square inches. All up weight came to 5% pounds. We still really haven't racked up enough time on the little version to decide whether we like it better than the big one or not. However, it is a nice size for transportation (Ed's note: Phil drives a prestige type Isetta convertible powered by the aforementioned Super Tigre), and quite possibly flies as well, or better than its larger predecessor. However, at 5% pounds and with the Veco .45, it does not bore through the maneuvers as well as the 7 1/2 pound Super Tigre versions. Therefore, as this article is being written, we are installing a .56 in the little ship and expect its performance to be most interesting.

To sum up, we believe the Kwik-Fli is about all you can ask for in performance for contest type aircraft. The framework, ready for covering, can be built in 16 hours. It is extremely rugged and easy to service. Outside of appearance, we don't think you can ask for much more.

### Wing Construction

Wing construction is entirely straightforward. Actually, you don't need the wing jig as shown on the plan, but it is highly recommended since accuracy is all-important in a contest airplane. Note that the wing is constructed outside down on the jig. This allows installing the landing gear mount during framing in order to minimize the construction time. We used structural epoxy cement for mounting the landing gear and in other areas subject to high stress. All servos are mounted with wood screws which we found to be entirely practical, saving a lot of time in fiddling around with the usual blind nuts or other types of hardware.

### Fuselage Construction

The fuselage must be constructed following the outlined steps exactly — each having been carefully planned to eliminate errors and for the fastest possible building time.

- (1) Cut 3/16" fuselage sides and doublers and glue together. Drill 5/16" holes for wing mounting dowels.
- (2) Laminate V4" motor mount bulkhead from 5 ply, V&" plywood.
- (3) Cut 2 pieces 1/16" x 6" x 24" for stab\* Mark rib positions and complete stabilizer.
- (4) Cut elevator from 2" x 1/4" stock, 24" long, and sand to shape.
- (5) Cut all fuselage bulkheads exactly as shown.
- (6) Splice a small piece at the rear of %" x 4" x 36" soft balsa to make top sheeting, starting rearward from hatch. Cut the front hatch from %" x 4" x 5%".
- (7) Mark positions of bulkheads and servo mounts on rear top sheet. Pick the straightest edge of a 3/8" top planking sheet, then draw a line lengthwise on this sheet 3 1/2" from edge. Cut a 1/4" slot on this center line for the fin. Using dividers, mark at F-5

and F-6 the position of outer edge, 1/2" triangular longeron. Pin the hatch block (front of F-2 forward) and rear top sheets (front of F-2 to rear) to a flat work surface.

- (8) Cement the y<\*' triangular longerons to the top sheets 3/16" from the straight edge of the sheets and 3/16" from the straight line previously drawn &/o" from the edge of the sheet. (Fuselage is straight to F-4) and bend around at rear to conform to marks at bulkhead positions. Taper at rear is indicated on top view of the plans.
- (9) Notch 14" into triangular longerons and install servo mounts. Position servos and mark mounting holes.
- (10) Cement in place all formers except F-1. Be sure they are vertical.
- (11) Set in place the 1/16" I.D. tubing push rod guides on the bulkheads.
- (12) Cement the fuselage sides in place, then add the 3/16" x 1/2" soft doublers to the rear on the 1/2" triangular longerons.
- (13) The stabilizer should now be sanded to shape and glued to the fuselage.
- (14) Install F-1 with structural epoxy cement.
- (15) Add the 3/16" x 1/2" hard bottom longerons and 1/8" x 3/8" stringers.
- (16) Install servos with wood screws, make up and install all push rods except to the rudder.
- (17) Add 1/16" ply front and 1/8" rear planking.
- (18) Fit finished wing to fuselage, checking for perfect alignment and proper decalage. The wing should be mounted with the leading edge approximately 3/32" lower than the trailing edge in the inverted position.
- (19) Remove the fuselage, carve and sand to shape, as shown. Cut out hatch.
- (20) Install the fin in slot previously cut in the top sheeting.
- (21) The engine is mounted on a 1/8" thick aluminum plate. The Super Tigre .56 and .60 and Veco engines all fit the same plate, except that 6-32 flat head screws are used to attach the mount to the Veco, while 5-40 are used for the Super Tigre. The engine is' mounted to the bulkhead with three 6/32 screws and double-nutted to prevent loosening. No side or down thrust is used. The final covering and painting of the airframe is up to the preference of the individual modeler.

## Flying

Before flying, it is important that the wing be balanced. If anything, it should be slightly heavy on the right hand side to help compensate for torque at low speed or under high-G loads. We, however, have merely balanced ours evenly. So far, all of the Kwik-Fli's have flown with no adjustments or trim whatsoever. Most of mine have come out either perfectly balanced or slightly nose heavy. You will not that the plans show a 2 to 1 reduction in aileron throw at the aileron bell cranks. Total aileron deflection is only about However, the ailerons are very large and very effective. The small deflection of the large area probably accounts for the aircraft's smoothness on aileron plus freedom from yaw during rolls.

The Kwik-Fli has worked very well for us and has been more or less adopted as a standard design for the immediate future. We hope that it performs as well for you.





## Product Report

A short while ago we accepted an invitation from Stu Babcock to visit Babcock Controls in their new facility at Laguna Beach, California. At that time, we also had the opportunity of touring the Babcock Electronic facilities a short distance away in Costa Mesa — the latter proving to be an experience that caused us to take an entire new look at the field of radio control. Here, more than a thousand employees were producing proportional radio control equipment for the Navy and other U.S. and foreign governmental agencies — equipment of such a nature that our own concept of radio control seemed diminutive by comparison. It was at this time that Stu Babcock announced that, following several years absence due to government commitments, he would be personally engineering and supervising the production of an all- new line of products for the radio control hobbyist. These items would incorporate new design concepts, and would include among others, a completely reliable single channel system for the sport flier, plus three complete proportional systems, all designed to the same standards of reliability and utilizing the same principles and concepts, of their government and military contract equipment.

### THE BABCOCK BC-21 SINGLE CHANNEL SYSTEM

The first offering from the newly reorganized Babcock Controls came in the form of a complete single channel system, designed expressly for the newcomer and sport flier. The appearance of the "21" system is the first indication that "something new has been added" to the R/C field. To begin with, the BC-21 is completely prewired with the exception of the connection of two wires to the escapement and the antenna lead, which remain unsoldered simply to facilitate the variety of possible physical installations. Included in the pre-wired harness is a switch panel with tuning points and snap on battery connector for the single, small 9 volt transistor battery that powers the entire airborne system. This system of providing a prewired harness greatly simplifies installation and obviates all but three soldered connections by the RC'er.



*BC-21 system is completely pre-wired, ready to install. Combines sharp tuning, extreme range, with interference immunity.*

# BABCOCK BC-21

**New single channel system from Babcock Controls a top buy for novice and sport flyer. Amazing range, interference immunity.**

### Transmitter

in its physical configuration, the BCT-21 transmitter differs only slightly from the vast majority of single channel units. But here the similarity ends. The RF section of the T-21 is composed of a drift transistor running in a crystal controlled oscillator with an input of 9 volts at 11 Ma (99 milliwatts input). This is a Part 15 transmitter, in accordance with Part 15 of FCC regulations, requiring a maximum of 100 milliwatts. The BCT-21 uses a 6000 cycle modulation frequency, which is completely legal under this section, and unlike Part 19 which requires a modulation frequency not higher than 4000 cycles. The tone is generated by a multivibrator of variable frequency, adjusted with a screwdriver from the front panel of the transmitter, due to the extreme selectivity of the receiver audio.

The modulator is a high level, series type, using no transformer, and with excellent response at 6 Kc.

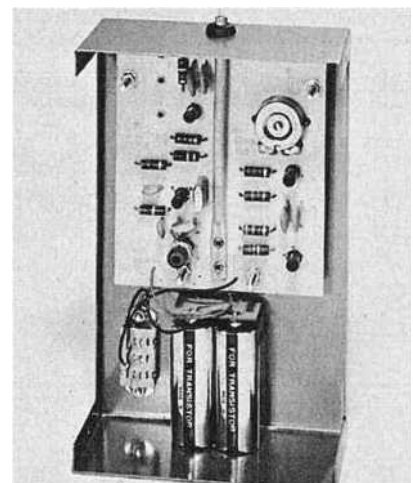

### BCT-21 transmitter

Modulation is approximately 90%. The simple wire antenna has its loading distributed through two loading coils, rather than one, showing radiation superior to any other antenna we have tested.

### BCT-21 Test Data

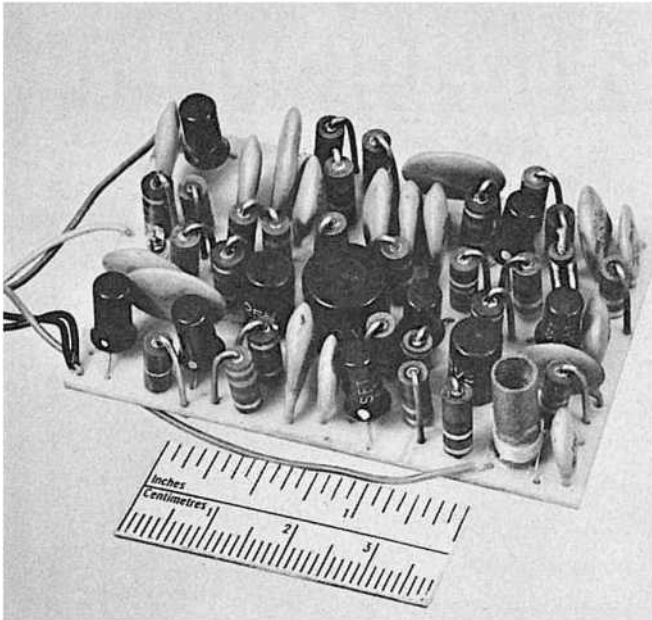

**New superregen design concept outperforms superhets in interference areas.**

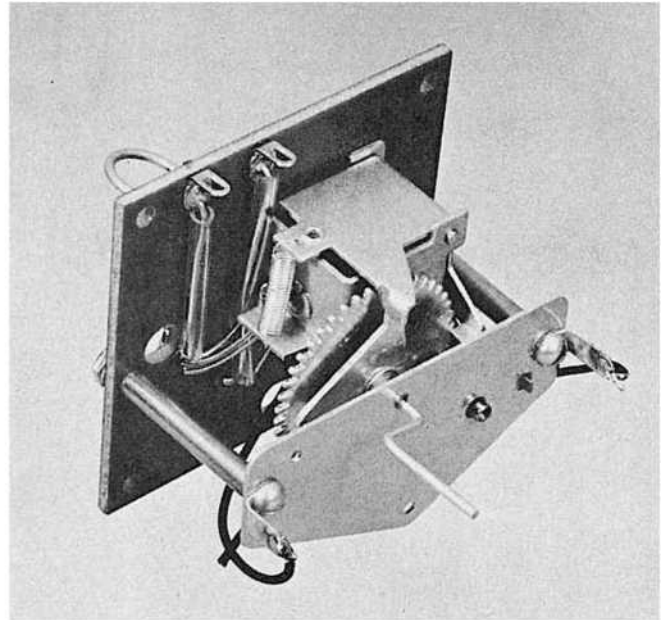

**Mark VII 9V escapement delivers power to the control surface an improvement over popular Mark II.**

**Voltage:** 18 volts (two small standard transistor radio batteries)

**Currents:** (antenna extended) Carrier: 12 Ma.

Tone: 22 Ma.

Tone Frequency: 6000 CPS

**Currents:** (antenna removed) Carrier: 10 Ma.

Tone: 20 Ma.

**Waveform:** Multivibrator almost sine wave at modulator.

**Stability:** Excellent

**Temperature Stability:** Slight audio drift but transmitter and receiver stay together with no variance.

#### **BCT-21 Physical Data**

**Size:** 6" high x 3-9/16" wide x 1-15/16" deep. Key button projection is 5/32".

**Weight:** 13 ounces

**Antenna:** 34%" extended including both loading coils. Consists of three sections of 3/32" wire.

**Case:** Rugged steel construction, blue and white finish.

**Controls:** On-off slide switch, audio key, tone adjustment. Back is removable, and secured in place by four sheet metal screws.

**Manufacturer:** Babcock Controls, Inc., 2762 Laguna Canyon Rd., Laguna Beach, California.

**Price and Availability:** Not sold separately. Entire system available

September 15, 1964.

#### **Receiver**

At first glance, the receiver for the "21" system looks like a superhet with the case removed. Quite to the contrary, however, the BCR-21 contains a superregenerative detector of a highly stable type. This is followed by two amplifiers, each of which is composed of a pair, of transistors in a circuit similar to the Darlington configuration with an inverse feedback filter. This pair of amplifiers gives an extreme degree of audio selectivity and completely eliminates the great attenuation normally needed to get rid of quench frequency. The last two transistors are a new version of the old and familiar trans-flex circuit. The **usable** sensitivity of this receiver is considerably better than 1 microvolt because of its very narrow audio bandwidth — in fact, this sensitivity was greater than we could measure with the available signal generator.

The selectivity of this new superregen receiver is excellent, and offers far greater safety in interference rejection than any superhet single or multi channel receiver we have tested. Deliberately introducing CB voice modulation, from a five-watt Hallicrafter CB unit did not activate the

system, regardless of channel frequency selected. In addition, several well-known single and multi-channel superhet rigs were set up with their respective escapements and servos and allowed to operate for several hours during a test period. All of the sets were triggered by Citizens Band voice interference from nearby stations with the singular exception of the BCR-21 which was completely unaffected. In addition, the other units could only occasionally trigger the Mark VII escapement, and then only when their transmitter antennas were fully extended and held within 12" of the BCR-21 antenna.

#### **BCR-21 Test Data**

**Voltage:** 9 volts for entire airborne system (single 9 volt transistor battery)

**Currents:**

No Signal: 5-6 Ma.

Signal: 10 Ma. (This figure reflects the total current for the receiver and escapement, with 90 Ma. being drawn by the escapement)

**Tone Frequency:** 600

**CPS Peak:** 5600-6400 CPS (adjustable at transmitter)

**Sensitivity:** Better than 1 microvolt (usable)

*(Continued on page 39)*



# FROM THE GROUND UP

by TED STEADED

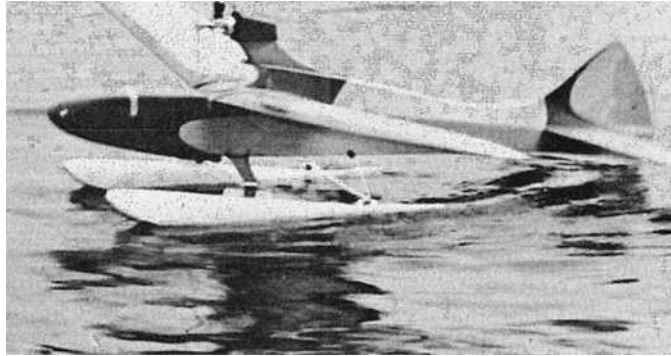

*Another chapter from the notebook of ROM's Dr. Strangelove...*

... do you have a new model transmitter with a center-loaded antenna? Got lotsa punch, hasn't it? Just remember that all that efficiency won't do you a fly-speck of good unless the antenna is FULLY extended! The loading coil can be shorted by the first antenna section out of the top of the coil assembly unless this section is pulled out as far as it will go. Of course this applies to the entire antenna. These loading coils are wound to accommodate, among other electrical characteristics, the length of the antenna used when fully extended. Full efficiency of the antenna cannot be realized unless this element is used in the manner prescribed by the equipment manufacturer. Nuff sed!

At about the time NATS activity was reaching a fever pitch, this modeler and one "trusted" aide were involved in a serious aqueous scientific experiment of such magnitude that only the denizens of Lake Pleasant were permitted to witness. (Except

for one startled early riser who watched for a brief moment from the questionable safety of the shore and then beat a hasty retreat into the wood!)

It was at this picturesque, watery indentation, amid the rolling elegance of the Adirondack Mountains near Speculator, N.Y., that we, my "trusted" aide Dale Springsted and I, decided to settle once and for all the oft asked question (oft asked by me) of whether the Gypsy could "make it" as a seaplane.

Much thought and speculation had been given to this combination — too bad as much time hadn't been spent preparing the test vehicle!!

One hour before my brood and I were to join his crew for the drive to camp and a pleasant weekend, he called and sez, "Hey, why doncha put those GeeBee floats on yer Gypsy and bring it along?" "Good idea," sez I, "I'll strap 'em on somehow and meet ya at the corner." ... the arrangement being that if he got to the corner first, he'd draw a line. If a got there

first I'd rub it out!

Early next morning, before the winds had a chance to become too brisk, we ferreted out a placid cove where our work could be conducted in a safe and orderly fashion. I was the mechanic, engine starter, switch flipper and photographer who would fail to record the whole ball of wax. (So, I'm excitable!!) Dale, my "trusted" aide, was elected to be pilot.

Let's digress for a moment and refer to the photos for one adjustment we made and one we forgot to correct. First the model sets too nose-high. In the other photo you'll notice this corrected but that one pontoon is angled more than the other one. During the first taxi session, Dale was doing a good job of controlling the ship but we couldn't seem to get up enough steam. To keep the ship from getting too far away he started a left-hand turn. This depressed the right pontoon which had been plowing until it went under enough to catch the right wing tip. As luck would have

**BONNER TRANSMITE SERVO SCHEMATIC**

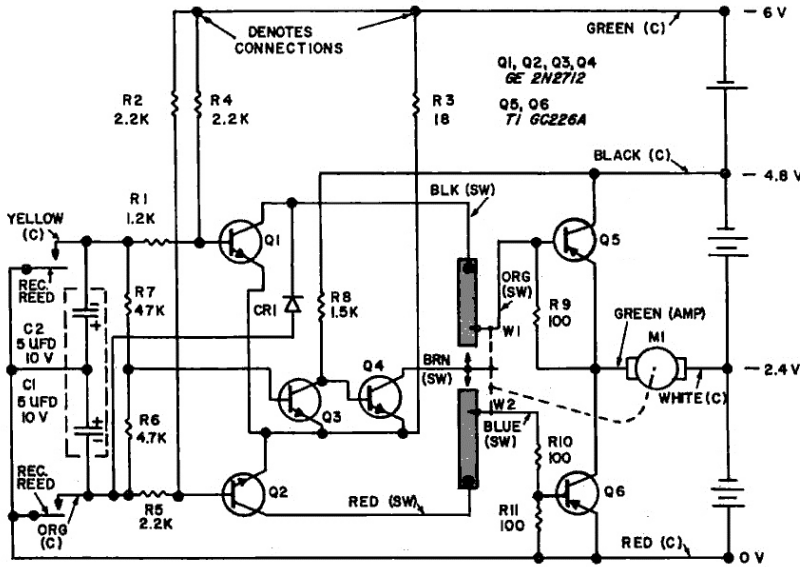

**FIGURE 1. SCHEMATIC**

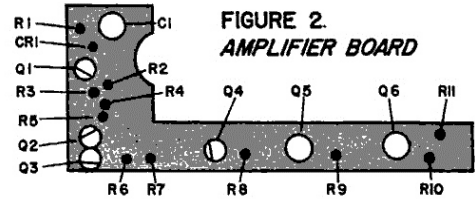

**FIGURE 2. AMPLIFIER BOARD**

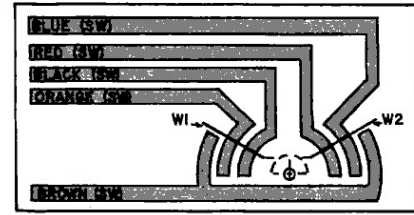

**FIGURE 3. SWITCHING BOARD**



**FIGURE 4. TRANSISTOR IDENTITY**

*The Bonner Transmite — the inside story of this popular servo.*

it this tip has a 1" slit in the silk which scooped water and must have shipped a gallon!

Another aggravation which had its effect was a badly-warped-down-elevator-effect in the stab. However, though we didn't make a successful R.O.W., we both learned a bit more about sea planes that day. It was generally agreed that if the Gypsy had a slightly larger engine and a kick-up elevator we would have been able to taxi nose high until the model could have become aerodynamically "buoyant" enough to escape its watery runway.

One thing I wasn't aware of until this soggy affair ended was that "trusted" aide Dale was actually using my poor old water-soaked sailplane as a training ground for the weekend when he'd have his finally-finished- Jenny-On-Floats ready for its own watery amphi-session! So who needs enemies?!!

For those interested, his Jenny is full-house with a .56 for thrust and the large sized (28") GeeBee floats for buoyancy. When he returns from the sea with his ship I'll try to get some photos of what's left and record them here.

The July issue of "Carrier Wave", the excellent club clarion of the Mc

Donnell R/C Model Airplane Club doings (St. Louis, Mo.) contained an extremely well detailed x-ray look at what makes a Bonner Transmitter servo "tick."

In view of the vast number of these servos in operation, we felt that passing along the observations of Bill Campbell is not only timely, but should be the type of material you'll feel compelled to refer back to, from time to time, regardless of whether you're-just moving into the advanced art of Multi or are there now and are beginning to ask yourself questions.

... So, with thanks to Bill, we present his account verbatim. Accompanying drawings of the circuitry and mechanics will help to clarify each step as you follow along. Those who find electronic jargon somewhat like Venusian Sandscrit may get some 'relief by biting on a length of old zinc pipe! Anyway —

"An important link in the resonant reed bank multi system in use is the servo amplifier. The amplifier receives an average of 3 ma of pulsed DC current from a reed and must amplify this signal to over 1 ampere as required by a starting, or stalled, servo motor. The amplifier is necessary because the resonant reed cannot handle the required 1 ampere motor current for any length of time before

it would become pitted or even welded inoperative.

Prior to 1961, the most commonly used amplifier was a SPDT (single pole-double throw) relay. In 1961 Bonner introduced his Transmitter servo amplifier which replaced the relay type amplifier with solid state circuitry which has proven to be much more reliable, vibration resistant, and trouble free. A slight cost increase, less space required, and nearly the same overall weight of the control system is also noted.

Figure 1, schematic, shows the electronic interconnections of the components which make up the Transmitter amplifier. Electrical connections are shown by conspicuous dots. Wires are color coded as they appear in the Transmitter servo. A (C) by the color code means the wire is found in the cable exiting through the grommet at the motor end of the servo. An (SW) means the wire is attached to the switching board located inside the cover of the servo. An (AMP) means the wire ties to the "L" shaped amplifier board from the component shown.

Figure 2, amplifier board, shows the approximate component location as viewed from the component side of the amplifier board.

*(Continued on page 34)*

Figure 3, switching board, shows the arrangement of the printed circuit switches and the spring finger wipers (W1 & W2) which comprise the travel limit switches and neutral return switches required by the amplifier. The wipers are mechanically tied together, but are electrically isolated. See the quadrant output gear in the Transmitter for details.

Figure 4, transistor identity, shows the lead location of various transistors which have been used in the Transmitter amplifiers since their introduction. All transistors are viewed as though you are looking at the top of the transistor case with the leads extending down and away from you.

Figures 1, 2 & 3 were developed from a 1963 manufactured Transmitter and uses the transistors called out in figure 1.

Earlier Transmitters used either the Sylvania 2N306 or 2N229 in place of the 2N2712 and used the Philco 2N223 in place of the TIGG226A. They did not contain CR1, this 'prevents damage in case both input reeds are closed at the same time diode, or RIO. R3 was 47 ohms and a 2.2K resistor was tied between 0 volts and the junction of the emitters of Q1, Q2, Q3 & Q4. R1 was 2.2K and C1 and C2 were two separate capacitors housed individually instead of being in a common case.

#### TRANSMITTER AMPLIFIER CIRCUIT OPERATION

DC pulses, when received on the yellow signal wire from a resonant reed, are filtered by C2 & R1 for Q1; and by C2 and R7 for Q3. DC pulses, when received on the orange signal wire, are filtered by C1 & R5 for Q2 and by C1 & R6 for Q3. Q3 conducts when either the yellow or orange wire is carrying a signal and cuts off neutralizing transistor Q4. Q4 is normally turned on (no signal) and supplies base current (approx/ 50 ma) to either Q5 or Q6 to neutralize the servo when no signal is coming in on the yellow or orange signal wires. Q1 amplifies the filtered 3 ma signals which arrive on the yellow signal wire and supplies approximately 50 ma to the base of motor power transistor Q5 which in turn supplies up to 1 ampere to the motor. Q2 amplifies the filtered 3ma signals which arrive on the orange signal wire and supplies approximately 50 ma to the base of motor power transistor Q6 which

turn supplies up to 1 ampere to the motor. Of course the direction of motor rotation depends upon whether Q5 or Q6 is conducting. R2 and R4 bias Q1 and Q2 off when no signals are incoming on the yellow or orange signal wires. R3 limits the current which Q1, Q2, Q3 & Q4 carry and also helps R1, R2, R4, R5, R6 & R7 to keep Q1, Q2 & Q3 cut off at higher temperatures, since any leakage current passing through R3 increases the reverse bias on Q1, Q2 & Q3. R8 is the load resistor for Q3. R9 & R11 bias Q5 & Q6 off during neutral conditions and are especially helpful at higher temperatures. RIO limits Q6 base current. "So observes Bill Campbell of the "hows" and "whys" a Bonner Transmitter servo does what it does when you command.

... sorry — you can let off on the pipe now!

Our thanks to Walt Watkins of Eatontown, NJ. for not only letting us in on his pulse servo experimentations, but also sending the unit so we could see it first hand. I tried to shoot it in the best manner to give you a good look-see, too.

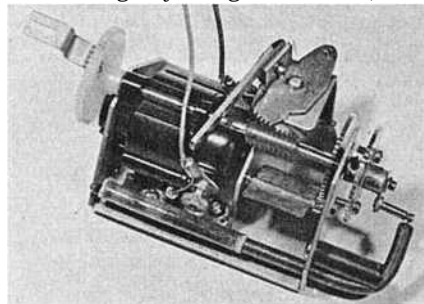

Walt is a relative newcomer. to Galloping Ghost, but is having much success in this area of control. His actuator is novel in that the rudder-elevator torque arm swings 180 degrees before it begins to engage any spring tension. Walt seems to feel that this cuts down the possibility of an unwanted complete cycle when effecting up elevator (slow pulse rate). True, there is a possibility of full-cycle servos, such as the Go-Ac, going completely through a revolution if your pulse box slow rate (for UP) is set too low. Walt's arrangement doesn't prevent this — but does initiate a

"soft" stop which acts as a snubber.

In this case the individual merits of the actuator are not nearly as important as the thought and initiative which went into its construction and the desire to try a form of flying that seems just a bit too much for all but the stout hearted to tackle.

To say that the G-G bug has bitten him bad is an understatement. Walt has G-G in a DeBolt Champ, a Skylark, and this unit pictured must be returned as it's out of his Go-Wind. (I thought I was smitten!!)

Returning to the pictures you'll notice a square object shaft-mounted just beneath the PTO worm. This is an air vane which Walt is using to give minimum friction drag — much the same as a star wheel in a compound escapement. Engine throttle thrust is supplied by a worm-spur combo, ala Du-Ac/Go-Ac.

So, what wild scheme have you come up with? How about sharing it with us? What you're doing, flying and fiddling with is of interest to modelers on the other side of town, so let us all in on the secrets! Nice glossy photos are always in season, too.

I have a sneaky suspicion that space is becoming a premium and I've got about a dozen notes jotted down of things to discuss. We'll have to carry them over into next month. A final reminder to drop me a note with questions, answers, ideas, sketches and pictures... we want in on what's going on.

Of course you've probably heard — though I think it's only a rumor— that D. Dewey, RCM's Editor, hopes to be the first guy on the west coast with his own R/C surf board!

See ya!

# RCM PRODUCT REPORT



## THE DEE BEE QUADRUPLEX

RCM tests Don Brown's proportional... a proven system, consistent in performance and reliability.

Several issues ago, when RCM began its discussion and examination of the various full-house proportional systems, we asked for letters of comment from individual owners of these systems. The response was immediate, frank, and to the point. In almost every instance, the "pros" and "cons" of a given rig were about equal. We say almost — for if it is possible for a manufacturer and his product to have a fan club, the honors go to Don Brown and the Dee Bee Quadruplex "21." From scattered points throughout the world, this one system not only received more letters than any other, but in each case the report was all on the plus side of the ledger. We wanted to know why.

The man behind Dee Bee Engineering is personable Don Brown. The son of a New Jersey dentist, Don started

in free flight during his school years — along with racing hydroplanes, and dabbling in amateur photography. His introduction to radio control came in 1952 in the form of an original, homebrew ship complete with hard tube receiver, escapement, and Cub .074 engine — all of which parted company with its owner on a first flight flyaway. This was followed by another, and somewhat more successful model, this time employing the old two-tube RK61 receiver. A Live Wire Senior with escapement operated elevator, rudder, and motor control provided an entire season of flying in 1953.

Don's introduction to proportional control started with a home-brew mechanical pulsar and Walt Good's Rudderbug. In 1955, this progressed to Galloping Ghost with which Don won top Intermediate class honors at the

1957 Nationals. This system was then replaced by Walt Goods' TTPW, and installed in an original shoulder wing design called the DB III. Its successor, the DB IV, carried Don Brown to third place at the 1961 Philadelphia Nationals and a berth on the U.S. Internal team. During this time, Don, along with Carl Schwab of Huntington Station, N.Y., was developing the first prototype model of the present Dee Bee proportional system. It was this system, in an original design called the Ambassador, that carried Don to fifth place at the '63 Internationals.

Since that early prototype, Dee Bee Engineering has grown to include, six full time and two part time employees, and has gained an enviable reputation in the field of proportional control. At the recent 1964 Dallas Nationals, Austin Left with flew to second place in

the Pylon event with the Dee Bee "21."

### General Description

The Dee Bee Quadruplex "21" is a triple simultaneous, fully proportional pulse servo radio control system. The number "21" stands for the actual weight of the airborne equipment — 21 ounces including the superhet receiver, servos and amplifier board, and nicad pack. The model "21" is completely pre-wired with the receiver and servo board connected by a permanent cable. Elevator and rudder servos are mounted on the glass epoxy servo board. When ROM's Editor received his Quadruplex, we found out just how easy this matter of installation becomes — the servo board was simply fastened to a plywood cutout frame and solidly mounted in the fuselage. The receiver was loosely wrapped in foam and mounted on end just ahead of the servo tray. The four "C" size, 1.2 amp nicad cells were wrapped in foam and installed under the fuel tank area — the pre-wired battery pack simply plugging into place on the servo tray along with the aileron and throttle servos. This pre-wiring and cabling provides the utmost in installation flexibility, and reduces to an absolute minimum the possibility of installation error. No soldering was required.

The Quadruplex "21" provides completely independent proportional control of rudder, aileron, and elevator, plus trimmable throttle. Servo power

is completely adequate for the full house competition models, while the airborne weight allows the use of the smaller .15-.19 size aircraft.

### Transmitter

Three simultaneously transmitted sub-carrier channels are employed by the Quadruplex "21" — 2.2 KC for Rudder, 2.8 KC for aileron, and 3.4 KC for Elevator. Time ratio modulation of the subcarrier is employed for independent control of rudder, aileron, and elevator position. 0% and 100% time ratio of the rudder channel is reserved for trimmable throttle control.

A blocking oscillator is used to generate a sawtooth waveform at the desired repetition rate of approximately 10 CPS. This sawtooth wave is A.C. coupled into the sawtooth segment selector. Trim and main control potentiometers are connected in such a manner that any portion of the sawtooth waveform can be utilized to control the time ratio of the subcarrier clamps. Each subcarrier clamp in turn modulates its respective subcarrier oscillator.

The subcarrier oscillator is a Hartley configuration. When the subcarrier clamp is conducting, the Hartley oscillator is turned off. When the subcarrier clamp is cut off the Hartley oscillator runs at its assigned frequency.

The output of each subcarrier oscillator consists of time ratio modulated bursts of sine wave subcarrier frequency. All three subcarriers are simul-

taneously mixed in the mixer amplifier stage, and are used to grid modulate the RF output stage that operates as an RF frequency doubler. Throttle control buttons simply turn the rudder subcarrier full off or on for trimmable throttle progression.

The transmitter itself is housed in a red anodized case measuring 10 1/8" high x 7" wide by 4" deep. The 4 amp hour nickel cadmium power supply is rechargeable through a front panel jack designed to accommodate the Dee Bee charger which charges the "21" receiver and transmitter simultaneously. Eighteen hours of charge at the fixed charger rate assures over three hours of transmitter operation.

The "21" transmitter features a single control stick for rudder, aileron, and elevator. A red and a black button on top of the case advances or retards the trimmable throttle. Two small knobs above and to the right of the central control stick trim the aileron and elevator. The position of these trim knobs does not affect the full deflection position of the servos.

One additional feature on this particular model is a switch, located next to the throttle buttons, which allows the rudder and ailerons to be coupled for those maneuvers or portions of the pattern where such a feature would be advantageous.

### Receiver

The superheterodyne receiver utilized in the airborne system is a two-deck, fully transistorized unit with no pulsing relays. The upper printed circuit

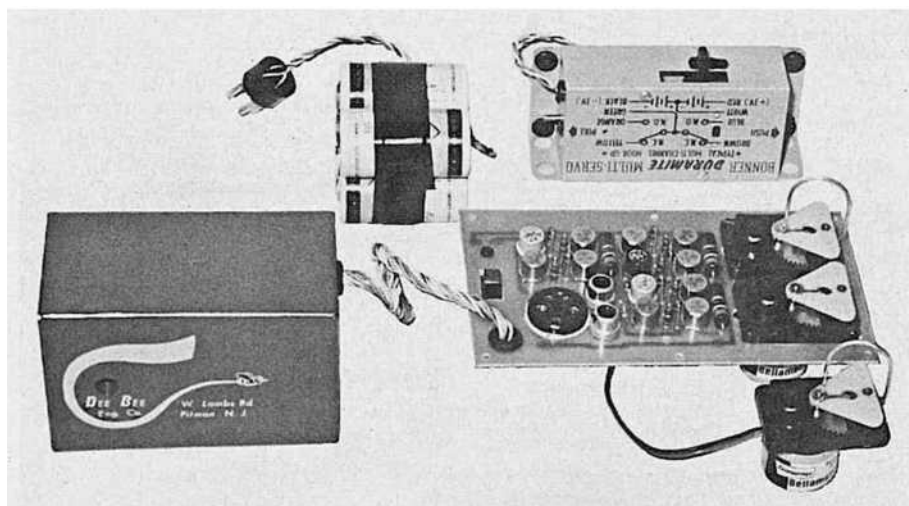

The airborne "21" system. Only change in RCM's test unit was an Ancco on throttle.

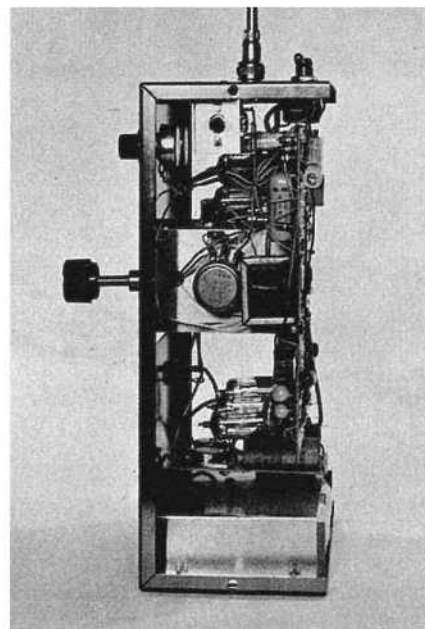

board comprises the superhet front end, consisting of RF mixer, local oscillator, IF amplifier, audio detector, and AGC, along with the motor control circuitry. The lower deck contains the subcarrier amplification, separation (filtering) and detection. stages. After the second detector, the three simultaneously received subcarrier bursts are fed into a common subcarrier amplifier that is essentially flat in response over the frequency range of 2 to 4 KC. At this point, the subcarrier output is applied to three series connected filters with center frequencies of 2.2 KC, 2.8 KC, 3.4 KC. The output of these filters is the time ratio modulated bursts of sine wave subcarrier exactly as transmitted. We have now only to convert these into bursts of subcarrier detector current to be used in driving the individual servo amplifiers.

When 0% or 100% rudder subcarrier is applied through the use of the throttle control buttons, as mentioned, a pulse omission detector transfers the voltage that would normally be applied for rudder operation to the throttle servo.

Tuning the "21" receiver is a simple matter of removing the transmitter antenna, and while holding the ship four feet or more above the ground, peaking the RF slug for maximum range (about 10 to 20 feet). Throttle retard should be checked and fine tuning accomplished to make sure that this function operates at half the range mentioned.

All components associated with Dee Bee's subcarrier filtering system are permanently potted in epoxy for maximum protection — a practice that has resulted in an experience record of **no** filter failures. One of the features we noted was that no attempt was made to "cram" the smallest available components into the smallest available area in the "21" receiver. Workmanship and layout are excellent, and all circuitry is contained in a heavy gauge red anodized aluminum case measuring 2" x 1" x 3".

### Servo System

The present Dee Bee Quadruplex is not a feedback proportional system, but rather, utilizes a pulse servo system of the most advanced design. When in operation, the slight quiver of the surfaces is barely noticeable,

and when in flight, the difference between this form of pulse and that of a closed loop system is not apparent.

Behind this particular system are several years of development, with the foundation of the servo system being the Micro Mo motor housed in the Graupner Bellamatic servo case. Beginning with this basic unit, Dee Bee replaces the centering system with a unique and extremely effective, torsion spring centering device. This modification is used on the elevator and aileron servos only, where extremely precise control is mandatory. The result is a centering action that is perfectly linear, and unmatched in fine resolution. As mentioned, the wiggle, or dither amplitude, is so infinitesimal, that in many installations it is not even visible.

The stock Bellamatic servo unit contains a slip clutch to prevent pinion damage in the event of extreme shock loads. This, too, undergoes further modification by Dee Bee, in order to deliver the higher power necessary for the high speed contest airplane. This modification, however, in no way nullifies the safety features of the original clutch design.

The rudder servo utilizes a scissor spring, rather than the torsion bar used on the elevator and aileron units, in order to maintain an absolutely solid neutral for the rudder and nose wheel in the absence of control command.

Elevator and rudder servos are mounted on a sturdy 2" x 5" fiberglass card that also carries the solid state servo amplifiers, off-on switch, and aileron and engine servos.

### Flight Tests and Conclusion

Our Quadruplex "21" underwent its first flight tests in a Zeus-Taurus combination. Frank Justin, RCM Associ-

ate Editor, removed his ten-channel reed unit and installed the proportional system with little or no modifications. Although Frank had not flown proportional control prior to these attempts, no difficulty of any kind was experienced, and the Quadruplex performed perfectly, flight after flight.

The photographs included with this article illustrate the installation of the "21" in RCM Editor Don Dewey's Glasquire a fiberglass version of the Tri-Squire, as manufactured by Ski Glas. Here, the "21" has been adapted for Class II flying, simply by removing the rudder servo from the amplifier board and installing the aileron servo in its place. In this installation, trim function is available on both the rudder and elevator. The weight of the airborne system, 21 ounces, is the same as most six-channel installations.

When we completed flight testing the Dee Bee Quadruplex "21," we knew why the owners of this system were spontaneous, and in accord, with their praise of Don Brown's product — it works, consistently and reliably. It is a system that the beginner to multi-channel will find much easier to handle than reeds. It will perform when you want it to perform. It will not have to go back to the factory for service after each few flights. We have heard it said that the "21" is not as exotic, or complex, design-wise, as some of the feedback systems. It is our feeling that this is exactly why its performance and consistent reliability is on such a high plane.

We like it, we fly it — and we recommend it to the RC'er who wants proportional control at a reasonable price, and with the assurance that it will perform consistently day in and day out.

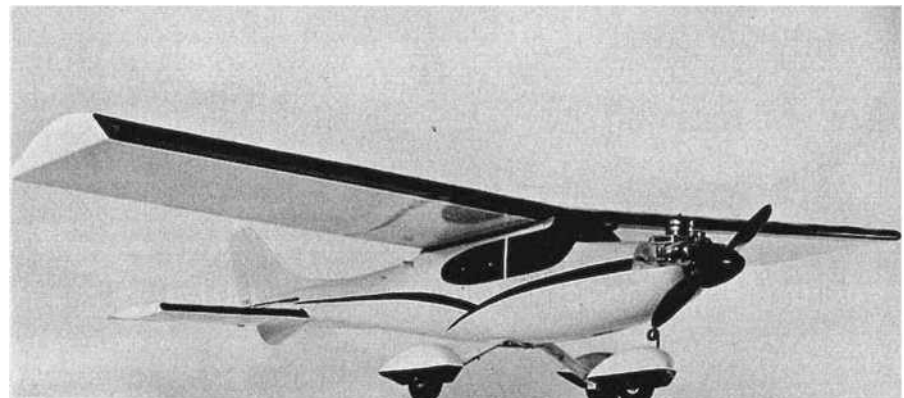

*RCM Editor's Glasquire — yellow, white, black.*



# SHOWCASE'64

**A subminiature Amplifier for Bellamatic servos** is one of several new items from Westee Imports. Size of this unit is only 5/8" x 3/4 x 3/4 with a weight of ounce, enabling the small but powerful Graupner servo to be used with relayless reed receivers. Weight of the amplifier and Bellamatic together is only 1% ounce. Standard color coding is used on the wires. A mounting bracket to accommodate two Bellamatic servos, together with their amplifiers will be available this coming Spring. With both servos and amplifiers installed, the total installation occupies a small space of only 2 1/2" wide x 1 1/2" long x 1" deep. Total weight is slightly over 3.5 ounces. Price of amplifier is \$9.95. Amplifier with Bellamatic servo, \$27.50. Bracket \$1.49. **Circle #1 on the Reader Service Card.**

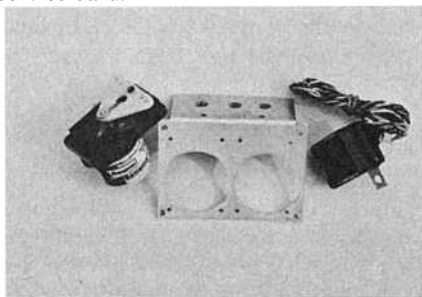

**2.4V — 3.6V Mah Power Pack and Car Cigar Lighter Charger.** Designed for single channel R/C equipment, this second item from Westee is a complete, encapsulated nicad system. A dual output enables the user to obtain not only power for his receiver and basic escapement, but also the extra voltage needed to pull in a secondary motor control escapement. The nicad pack has a molded in-place five pin plug matching the socket of the charger. An Aristo 5-pin connector is used. The weight is only 2 ounces — 1/2 ounce less than 3 alkaline energizer pencils. The charger will fully charge the pack in 12 to 14 hours, and is designed to plug into the cigar lighter in a car with 12V system, negative ground. Drain is negligible

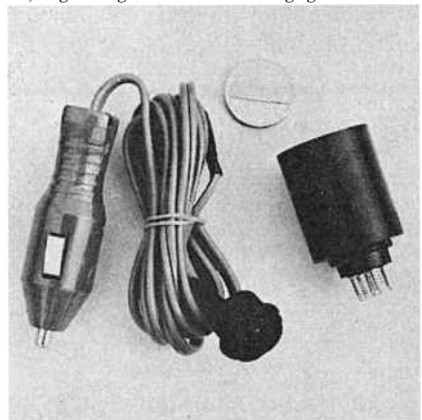

(20 ma) and charging can be performed with the car motor off, or running. Price of both the charger and nicad pack is \$12.95. Charger only, \$3.50. **Circle #2 on the Reader Service Card.**

**Newly designed Strip Hinges** are now available from DeBolt Model Engineering Co. Strip hinges are not new, for during the past few years they have proven to be simple to use and completely invisible when installed in the proper manner. One drawback, however, has been that they were not as flexible as the more common woven thread type. Demco's new strip hinges are made from a different type of plastic which gives the desired flexibility when properly installed. The plastic is not only unusually flexible and strong, but has the quality of becoming more flexible with use. A complete set of strip hinges, enough for a complete multi ship, is 49¢. We have examined this item and found it to be quite an improvement over the standard mylar hinge, recommending them to your consideration. **Circle #3 on the Reader Service Card.**

**The Scorpion**, a 56" span shoulder wing design for six channel through full proportional, is the newest offering from Kustom Kit's. A Ted Strader design, the Scorpion is not only an excellent kit, in keeping with the usual high Kustom Kit standards, but is an outstanding flier. This is not a design that the sport flier should shy away from, for although it is very maneuverable, it is rugged and forgiving. For .09 to .19, the Scorpion is priced at \$14.95. The **Gypsy glider** is an exceptional flier, and one that has been thoroughly tested by RCM. For slope soaring, or .049 to .07 mill, it will accommodate single channel equipment and escapement, or a multi servo. Price is \$11.95. Both kits distributed by Special Editions Plans. **Circle #4 on the Reader Service Card.**



**No-Noise Nylon Control Cable Sheathing** has been released by Midwest Products as part of their line of R/C accessories. When used to sheath the throttle and brake cables, this item will eliminate the vibration induced radio interference which often occurs when metal tubing is employed. Formed from special molded nylon, the outside diameter is .097, with an inside diameter of .066. Price is 35¢. Recommended by RCM. **Circle #5 on the Reader Service Card.**

**A Single Channel Closed Loop Feedback Proportional System** has been announced by Keystone Products, Inc. This is the newest addition to their line of 6 and 12 channel transmitters. From all indications, this new system should receive a wide degree of acceptance from Class I enthusiasts. For a catalog on the Keystone line, **Circle #6 on the Reader Service Card.**

**Pulsmite 800S New Single Channel Proportional** offering from Min-X features a built-in, fully electronic pulsar, according to Jack Lemon, Min-X engineer. One of the outstanding features of the new transmitter is that is designed to provide pulse-proportional operation with any existing superhet or superregen receiver that will accept an 800 CPS tone. Named the Min-X Pulsmite 800S, this exclusive new transmitter offers exceptionally smooth and sensitive single stick operation of both rate and width, including trim for each. The use of a double-yoke stick control incorporated with a unique stick mount eliminates the jerky, click-type control associated with many rate-width pulsars. The pots are mounted on the circuit board which virtually eliminates the possibility of wire breakage. Two push buttons are utilized for full ON and OFF tone switching. Physical size is 6 1/2" x 5" x 6 1/2" Weight is 2 pounds including battery. The 9 volt supply will give approximately 30 hours of flying time. The center loaded antenna is 24" in length, fully extended, and 12" retracted. Price is \$59.95. A 90 day warranty accompanies each unit. **Circle #7 on the Reader Service Card.**

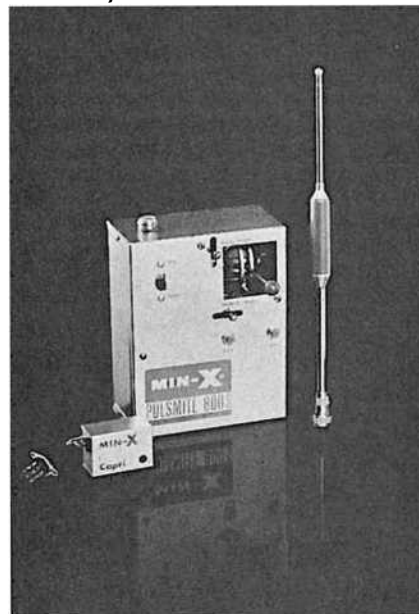

**R/C Special Products Nose Gear Bender** is a simple and durable device for cold forming spring coils and right angle bends in music wire up to 5/32" diameter. The bender is made entirely of steel with a rust-resistant black finish, except for the handle which is zinc coated. The mandrel pin is hardened and ground for long life. A hardened hex socket set screw and wrench is provided for clamping the music wire in the stationary block. With this bender the RCer can produce a professional nose gear with the proper dimensions and number of coils to suit any given design. We have examined this unit and find it to be of the highest quality, simple in operation, and professional in its results. Price is \$3.95. For further information **Circle #8 on the Reader Service Card.**

The Shoestring and Miss World's Fair are two newly developed and thoroughly tested R/C models from Scientific Model Airplane Co. Both ships are of all balsa construction, and designed around the popular lightweight, relay less single channel gear and the Cox .020 power plant. Specifications for both designs are: .30" span, 21" length, 12 ounce weight. Price \$3.95 each. Circle \$9 on the Reader Service Card.

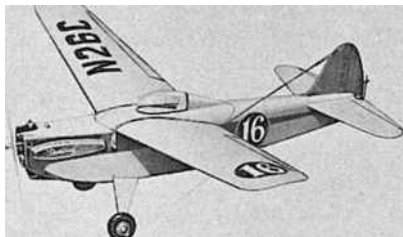

## Product Report

(Continued from page 35)

**Interference;** With carrier on, the receiver was immune to any form of noise, adjacent channel interference, CB voice interference, or from radiation by another receiver regardless of proximity of adjacent units.

**Combined Range Check;** 4400 feet consistent ground range. Manufacturer guarantees 1500 feet minimum.

**Swamping:** None, regardless of proximity of receiver to transmitter.

**Temperature Stability:** Response was flat from 30 to 120 degrees F. The "21" will continue to operate at both higher and lower temperatures.

### BCR-21 Physical Data

**Size:** 21" length x 1 1/2" width x 1" depth.

**Weight:** Entire airborne system, including receiver, Mark VII escapement, 9 volt battery, harness, switch, and wiring: 4 ounces.

**Antenna:** 18" vertical wire whip with double loading coils.

**Case:** None

**Manufacturer:** Same as transmitter

**Price:** Not sold separately. Entire system price, including transmitter, receiver, Mark VII escapement, and wiring harness, \$49.95.

### Mark VII Escapement

The Mark VII escapement is a new version of the ever-popular a new version of the ever-popular Babcock Mark II. It utilizes a 100 Ohm coil with the receiver putting .9 watt across this coil, a major advantage over any other relay less receiver. Of the 9 volts- available, 8.8 volts appear across the coil, even under weak signal conditions. The escapement is 1 square and gives right and left, as well as up elevator. No provision is made for motor control, although the more experienced modeler could easily add the necessary quick-blip contacts. It is our opinion, however, that motor control for the smaller R/C model is an unnecessary complication.

## FINDINGS

Tuning of the Babcock BC-21 system is accomplished by the use of a small bulb (provided) which is attached to the pre-wired test points and tuned for maximum brilliance. Final tuning results from turning the tone adjustment on the transmitter until both transmitter and receiver audio are exact. No long distance range check is necessary.

Flight testing was conducted by Bill O'Brien, RCM Consumer Research Editor, using a Blackwell Snapdragon 44 with Cox .09 as a test ship. The "21" was flown extensively, and at no time did it malfunction, run out of range, or fail to respond to a given command. Air range was O.O.S. All parts of the system performed to complete satisfaction. Installation was completed in less than fifteen minutes, including making a bulkhead and installing the escapement.

Following the testing of the BC-21 system, we find that it exceeds the manufacturers specifications in all respects, the latter's claims being somewhat on the conservative side. In fact, this is the one we've been Waiting for — a package system designed with the beginner and sport flier in mind, and with virtually all of the common fault of single channel eliminated. Range, selectivity, ease of installation — all are exceptionally outstanding and reflect excellent design consideration. Such features as using two small readily available and economical transistor batteries in the transmitter and one for the entire airborne system bears out the consideration given to the needs of the sport flier.

It is our consensus of opinion that this is an ideal single channel system for the beginner and sport single channel flyer. Performance-wise, the "21" system equals or exceeds any system or combination of components in its class. When performance and price are considered, it is without question an exceptional buy.

RCM recommends the Babcock BC-21 system as specified, and without reservation, for the single channel sport flyer or novice.

Dwight F Brooks' six-foot Ichiban is one of the most magnificent RC sailboats we have ever seen. The fibreglass hull is a Rhodes design. Teak stripping was used for the decks. Cabins are of Luan mahogany and are fitted with plexiglass windows set in metal rims. Sails are of Dacron spinnaker cloth complete with battens and headboard. A Pittman motor is used for auxiliary power. Eight channel Orbit equipment in the radio compartment operates Transmite servos. Two lights are mounted on the first spreader bar to illuminate the deck for night operation. Beam is 18", freeboard 6", draft below water line 23", weight 98.6 pounds. Mast height, 88". Speed under power is 6 m.p.h., and under sail, 4 m.p.h.

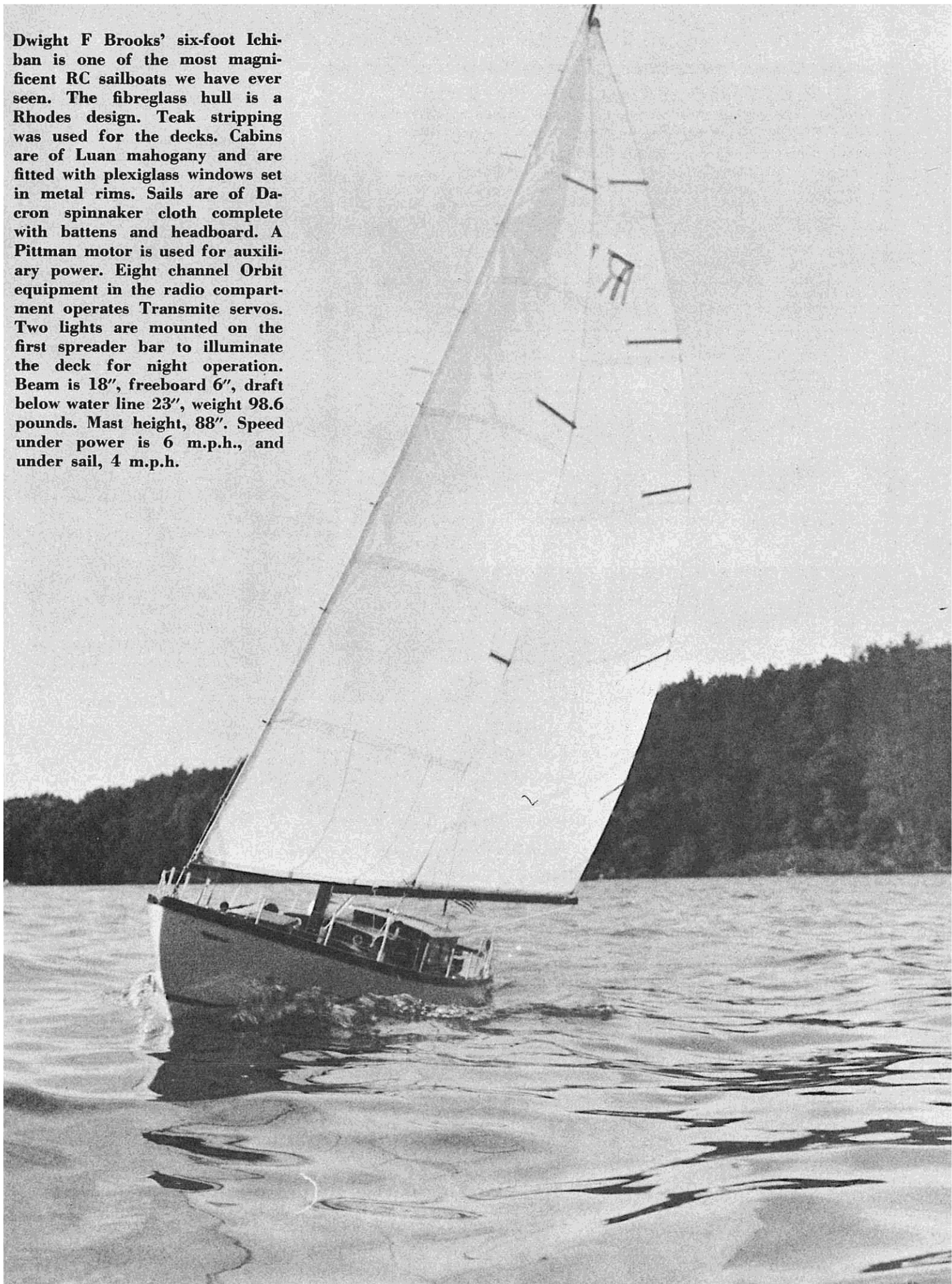

## Comment by

## George Wells

### If It's Free Why Pay For It?

"Ask not what your Country can do for you, but what you can do for your Country."

It seems strange that one of President Kennedy's most remembered statements seemed to be directed at the nation's freeloaders. Perhaps "free-loaders" is a harsh term in this context, because practically everyone pays taxes in support of the Country, and theoretically deserves something in return.

What does this have to do with the ambrosial world of R/C, where people go for temporary relief from politics and other annoying things? Very little, except in one respect. A mild form of free loading exists in R/C. Yes, it does. But it can be stamped out very easily.

As one's .020 squeals to life on the first flip, or as one enjoys the sensation of the afternoon's first outside loop, how many of us contemplate the vastness of this R/C complex to which we belong? If any flier does, he must be sick, because such thoughts have no place on Sunday afternoon, much less a miserable Monday morning.

But, suspicious as it may seem, there are people who do concern themselves quite thoroughly with the vastness of R/C — the very people who helped make it vast, and who want to keep it that way. These are the "dedicated" ones. Every club has at least one or two. Odd ducks, some of them, you might think; so busy making work out of this hobby, they don't have much time to fly.

They are always busy organizing contests, fly-for-fun events, contributing ideas at club meetings, and writing letters. "Well, if that's their kick," says Charlie Buzzjob, "they're welcome to it." "Me, I'm here to fly." He

leaves the more reflective moods to others who must sometimes admit, thank God for those who care.

For it is the dedicated ones who make R/C so enjoyable for the rest of us. It is the dedicated ones who keep club activities alive, and help provide purpose to what could be no more than just a bunch of guys knocking around. Usually, their dedication goes beyond the club level. They have stepped back far enough\* from the whirling Top Flites to see the bigger picture.

In some areas, this is a regional federation of clubs, a larger group of fliers to get together and share ideas, laughs, and problems. From there, R/C takes on national and international aspects. But, it is still the dedicated ones in the clubs who make the national picture possible, with the help, of course, of a national organization to coordinate their efforts.

Well, who are the free loaders? Certainly not the dedicated ones. And not necessarily guys like us who just like to fly, because without our contributions, just as fliers, the dedicated ones would have no one to dedicate themselves to. It seems that one needs the other. And, the clubs need to be part of the bigger picture. And the bigger picture needs the clubs.

During the past year, AMA has filed a petition before the Federal Communications Commission requesting more radio frequencies in various sections of the available spectrum for radio control model flyers now numbering more than 50 thousand in the United States. The organization maintains additional frequencies are necessary due to interference from other Citizens Band communicators, to insure the safe conduct of the sport and hobby. It is supported in this request

by its 20 thousand members, many of whom have contributed considerable time and money to the R/C frequencies problem. It has also served the interests of many other nonmembers by representing all R/C modelers before the FCC.

On another front, the Academy soon is expected to meet with Federal Aviation Agency officials concerning proposed FAA limitations on model flying near airports and controlled airspace. AMA is expected to request that - if altitude limitations must be placed on model flying, the controls be the minimum required in the interest of safety; again representing all modelers rather than just AMA'ers.

Also, the Academy is involved in considerations for special services for R/C within AMA so that more attention may be directed at the special problems involving this activity which do not concern the general membership, and to provide improved services to this group ...

"Yuk", says old flying buddy, Charlie who never listens to commercials. "The next thing this guy is going to say is that we all should join AMA. Horseshoes! Who need it? I got all the insurance I need. I got a nice little place to fly, and I ain't interested in contests. All that AMA rag, Model Aviation, talks about is other guy's troubles: flying sites, rules, other kinds of model flying, kid stuff. Just leave me be."

"By the way, you got any extra fuel?" says Charlie. He never buys any, figuring someone will take care of him at the field.

Nice guy, though.



**Airport Xanthi 1**



**Airport Xanthi 2**



**Airport Xanthi 3**



**Airport Xanthi 4**



**Airport Xanthi 5**



**Airport Xanthi 6**



**Airport Xanthi 7**



**Pilots (Hlsat,Savvas,Kostas)**