

The
CONTROL LINE
Aeromodeller

95p
USA & Canada \$3.95

**Sports Model Plan
Practical Hints
and Tips**



**Interviews
With
Experts**

**an AeroModeller
Magazine *Extra***

MAP HOBBY PUBLICATION

Control Line Accessories from

IRVINE

Pylon Brand instant-use control line cables and storage reels

| | | | |
|------------------------|-------|------------------------------|-------|
| 008" (2 x 26ft) | £1.40 | 015" (2 x 70ft) | £3.15 |
| 012" (2 x 35ft) | £2.25 | 018" (2 x 52ft) | £2.95 |
| 012" (2 x 52ft) | £2.95 | 018" (2 x 60ft) | £3.15 |
| 015" (2 x 60ft) | £2.95 | 018" (2 x 70ft) | £3.70 |
| 015" (2 x 52ft) | £2.95 | Storage Reel 4" dia ... | 38p |
| 015" (2 x 60ft) | £3.15 | Storage Reel 5" dia (deluxe) | £1.20 |

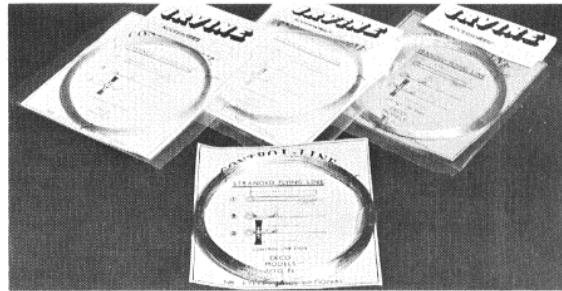
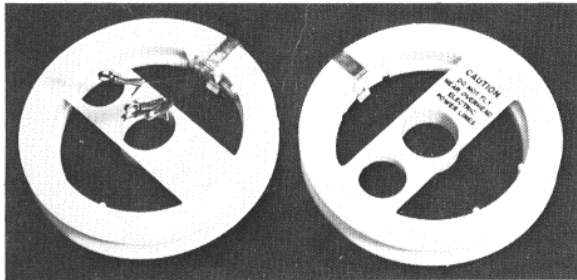

▲ Irvine multi-strand Control-Line wire

| | |
|--------------------------|-----|
| 70ft Lightweight | 54p |
| 100ft Lightweight | 67p |
| 70ft Heavyweight | 65p |
| 100ft Heavyweight | 84p |

Mercury Fuel Tanks ▶

| | |
|--------------------------|-----|
| 7½cc team race | 48p |
| 10cc team race | 48p |
| 15cc team race | 54p |
| ¼A Wedge tank | 48p |
| 1½" Wedge tank | 58p |
| 2" Wedge tank | 64p |
| Combat Wedge tank | 64p |
| 2" pressure tank | 62p |
| 2½" pressure tank | 64p |
| 3" pressure tank | 68p |

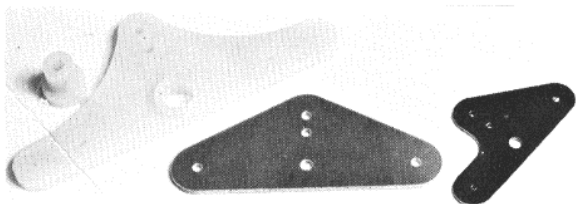
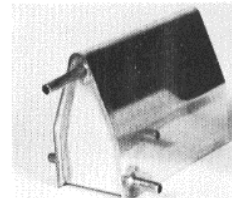
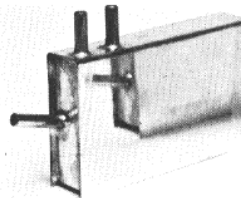
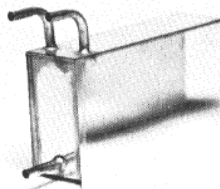

◀ Bellcranks

| | |
|------------------------------|-----|
| Mercury 3" heavy duty | 19p |
| Irvine 1½" paxolin | 9p |
| Irvine 2" paxolin | 14p |

Sullivan Adjustable Control line handles

| | |
|---|-------|
| P.85 — small adjustable | £1.15 |
| Sullivan Pro-Handle — adjustable | £1.35 |

Sullivan lead-out cables ▶

| | |
|-------------------------------|-----|
| Class A-B loop end kit | 65p |
| Class C-D loop end kit | 65p |

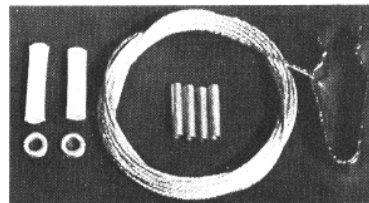
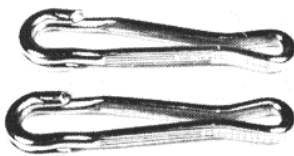

◀ Sullivan line connectors

| | |
|-------------------------|-----|
| Small (packet 2) | 25p |
| Large (packet 2) | 25p |

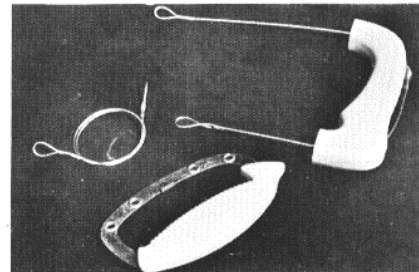

Available through your local hobby dealer



IRVINE

IRVINE ENGINES,
UNIT 8, ALSTON WORKS, ALSTON ROAD,
HIGH BARNET, HERTS. Tel: 01-440 0923

The CONTROLLINE Aeromodeller

an Aero Modeller extra

Editorial Director
R. G. Moulton
EDITOR
P. S. RICHARDSON
Manager Director
Gospatric Home
Production Manager
A. Dowdeswell

This Special edition of *AeroModeller* is sold subject to the following conditions that it shall not, without the written consent of the publishers, be lent, re-sold, hired out or otherwise disposed of by way of the Trade at a price in excess of the recommended maximum price and that it shall not be lent, re-sold, hired out or otherwise disposed of in a mutilated condition or in any unauthorised cover by way of Trade, or affixed to or as part of any publication of advertising, literary or pictorial matter whatsoever. Second-class postage rates paid at New York, N.Y. Registered at the G.P.O. for transmission by Canadian Post. American enquiries regarding news stand sales should be sent to - Eastern News Distributors, 111 Eighth Avenue, New York, N.Y. 10011, U.S.A. Telephone (212) 255-5620 and Hobby Shop Sales to Bill Dean Books Ltd., 166-41 Powells Cove Boulevard, Whitestone, New York 11357, U.S.A. Telephone (212) 767-6632

Subscription Department: Remittances for regular 12 months supply of *AeroModeller* to Model & Allied Publications Ltd., P.O. Box 35 Bridge Street, Hemel Hempstead, Herts HP1 1EE (subscription queries Tel: 0442 51740). **Subscription rates:** Inland, Sterling £5.75 per annum, including index; \$12.00 (U.S.) for overseas subscribers.



HOBBY PUBLICATION

**MODEL & ALLIED
PUBLICATIONS LTD.**

**P.O. Box 35, Bridge St., Hemel
Hempstead, Herts, HP1 1EE**

Tel: Hemel Hempstead (0442) 63841-2-3

Publishers of: Scale Models, Aero-modeller Model Boats, Radio Control Models, Military Modelling, Model Engineer, Model Railways, Wood-worker, Gemcraft, Photography, Movie Maker, Battle, Puzzles Digest.

- 8 FOAM FOR ALL**
Why use balsa wings? Why indeed . . .
- 12 TRIMMING PROCEDURES FOR STUNTERS**
Do it right, and the benefits are a model that flies correctly - and better.
- 16 ON THE LINE**
Control-line is the name of the game - so pay attention to getting this detail correct.



- 20 PLASTIC PLANES**
Yes they do fly well - but learn how to avoid making these (costly) mistakes.

- 24 THIRD LINE CONTROL**
See how the maestro gets really s-m-o-o-t-h throttle control - and other functions too.

- 26 EXPERTS INTERVIEWED**
Series of searching questions, and revealing answers, provided by top modellers.

- 35 MINI SLOW**
Plan and construction feature for this multi-role design. Cheap to build - great to fly.

- 43 COMBAT DESIGN**
What will the next trends be?

- 46 FUEL TANKS FOR STUNTERS**

How to get that precious liquid into the engine, no matter what attitude the model is maintaining.

- 49 FLY THE SCHEDULE**
The 'Bible' for would be precision aerobatic fliers. Learn from 'Uncle Jim' - then go out and beat him!

- 54 HINGING METHODS**
How to connect the tailplane and elevator together whilst retaining full control.

- 56 BREW-IT-YOURSELF**
Fuel that is - diesel and glow - but definitely not for internal consumption!

- 60 A ROSE BY ANY OTHER NAME**
A simple lesson in cosmetics - or how to fool your friends.

- 62 FLY-FOR-FUN SCALE**
A practical approach to scale modelling - for the non-purist, but the *active* flier.

- 66 A LITTLE PIECE OF HISTORY**
An all metal team racer flown competitively 20 years ago? It's all true!

- 68 CLASSIC CLARKSON QUICKIES**
A round-up of useful hints by *AeroModeller's* control-line contributor.

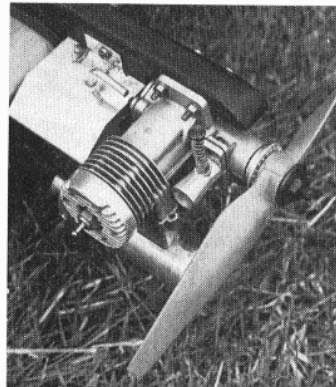

**New From PEERLESS
AT YOUR MODEL SHOP NOW**

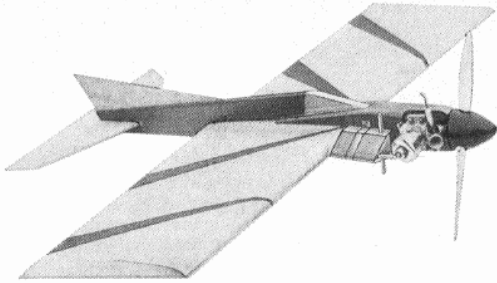

PREDATOR

21in. wingspan combat trainer. All parts die-cut and pre-sawn makes it a real quickie to build and fun to fly. Kit contains ready to use combat tank, all engine mounting nuts and bolts, bellcrank, horn etc. Recommended engine sizes: 0.75cc - 1.00cc - .049cc - .06cc.

REC PRICE £3.35 INC VAT

PEERLESS MODELS LTD.
103 WOLVERHAMPTON ST.,
WALSALL,
WEST MIDLANDS.

**Model Technics
MOLECULAR BLENDED FUEL**

Made from the highest quality, batch-tested ingredients and formulated in consultation with engine expert Peter Chinn. Pure, clear fuels blended by the latest technology (molecular dispersion), which really stay mixed. And since no single fuel can supply the various needs of all types of engines, Model Technics offer a range of 19 GLOW FUELS and 3 DIESEL FUELS. So now you can choose the BEST POSSIBLE FUEL for your engine, and operating requirements.

The same high quality materials are also available separately for the 'home brew' modeller in a wide range of sizes—and at highly competitive prices.

**½ litre TINS from 35p
1 gal POLYCANS from £2.70**

(depending on fuel formulation) also available in ¼ litre CANS and 1 litre and ½ gallon POLYCANS.



**Model Technics
MOLECULAR BLENDED FUEL**



FORMULATION CONSULTANT: Peter Chinn
ABOUT MODEL TECHNICS
The Model Technics fuels at Shoeburyness have been purpose designed and built to the highest quality and care. A major factor in the success of the fuels is the use of the latest technology (molecular dispersion) which really stay mixed. And since no single fuel can supply the various needs of all types of engines, Model Technics offer a range of 19 GLOW FUELS and 3 DIESEL FUELS. So now you can choose the BEST POSSIBLE FUEL for your engine, and operating requirements. The same high quality materials are also available separately for the 'home brew' modeller in a wide range of sizes—and at highly competitive prices.

FREE LEAFLET

All about Model Technics fuels, plus a FUEL SELECTION CHART giving recommended fuels for over 140 engines. From your model shop, or send large SAE to Model Technics Ltd., Vanguard Way, Shoeburyness, Essex SS3 9QY.



·049 Glow

SPORT FLYERS ENGINES

DAVIES-CHARLTON LTD. HILLS MEADOW DOUGLAS, ISLE OF MAN

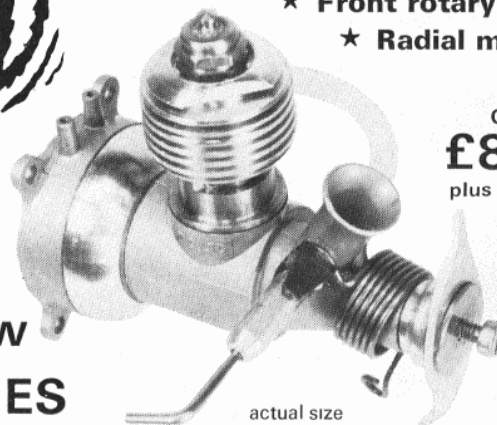

actual size

QUICKSTART

- ★ No backwards starts
- ★ Light but really powerful
- ★ Integral tank
- ★ D-C Glowplug
- ★ Front rotary
- ★ Radial mount

ONLY
£8.24
plus 66p VAT

KINDLY MENTION 'AEROMODELLER' WHEN REPLYING TO ADVERTISEMENTS

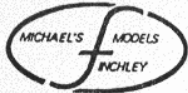

MICHAEL'S MODELS

646-648 HIGH ROAD, N. FINCHLEY,
LONDON, N12 0NL Phone: 01-445 6531

Leading Control Line Specialists

Open 6 Days a Week

9.00-6.00

MAIL ORDER A PLEASURE.
EXPORT ORDERS WELCOMED.

SEND S.A.E. FOR C/L OR
ENGINE LIST.

All enquiries must be accompanied by SAE.

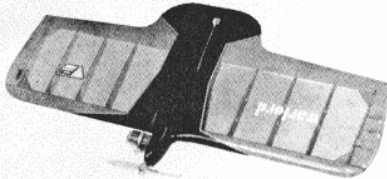

WARLORD £5.09
Surely one of the most popular C/L kits around and with good reason! Designed by Vernon Hunt, this model is terrifically strong yet highly manoeuvrable and has many contest wins to its credit. All wood parts are cut to shape and kit contains a genuine mustard tin tank kit, nuts and bolts, paxolin bell crank, leadouts, pushrod, horn, cloth hinge tape, transfers, a plan and building instructions 32in. span for .15-.19 engines.



GINNY £6.77
32in. span C/L Goodyear model for .15-.19 engines Very strong all-sheet construction. All balsa ply and hardwood parts cut to shape; new lightweight circular bellcrank, tank, nylon wheel, pre-formed undercarriage leadouts, pushrod, horn, hinge tape, undercarriage clamp, all hardware, transfers etc. A very complete kit for a highly competitive model. Also makes an excellent trainer with a moderate .15 engine.

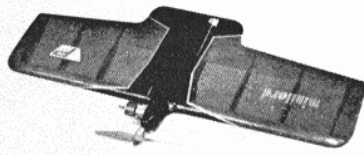

MINI-LORD £3.80
Smaller version of the Warlord for .09 (1.5cc) engines with all the outstanding characteristics of its big brother. All wood parts, 0A uniflow tank, bellcrank, leadouts etc. Though not strictly a trainer, we know scores of people who have successfully built and flown Mini-lord as their first C/L model.

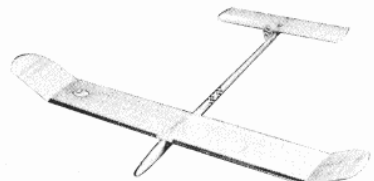

PLOVER £4.86
45 1/2 in. span all-balsa glider to AI specifications using the 'Jedelsky' wing principle. All balsa and hardwood parts machined or die-cut, easy to follow instructions and assembly sketches, flying instructions coloured trim tape, etc. Very simple to build and a fine performer—an ideal introduction to the sport of aeromodelling.

POSTAGE 54p PER KIT

| ACCESSORIES | |
|--|---------|
| Control line speed calculator | £2.43 |
| 1 1/2 in rotary bellcranks | 42p |
| Cycle 'pushrods' spokes | 4p each |
| Small metal bellcranks | 10p |
| Tanks 7 1/2 cc | 36p |
| 10cc | 38p |
| 15cc | 40p |
| 30cc | 44p |
| Props by KK, Tornado, Taipai, Topflight, Puntillo, Graupner. New type Tornado 7 x 4. Box | £4.32 |
| Mustard tin tanks | 40p |
| Irvine test stand | £7.95 |
| Rubber fuel tubing 40in | 44p |
| Rubber chicken finger | 28p |
| Ampmeter 5 amp for glow plugs | £1.10 |
| Plug, Tidy | 39p |
| Nissin Tacho | £18.25 |
| Plugs by Taylor, Fireball, Globee, Hotspot, Fox, O.P.S. | |
| David razor plane | £1.95 |
| Box of modelling pins | 49p |
| Box of 1000 pins | £3.50 |
| Nylon 1sq yard | 45p |
| 3sq yards | £1.35 |
| Red, blue, orange, white, yellow, Flexigrit sandpaper | 35p |
| 'J' bolts (4 per pack) | 32p |

Send SAE for complete list of our engines and C/L accessories.

We stock Rossi, S.T. Cox spares. Listed above is just a small selection of our stock visit our shop or send SAE for full list.

Diesel conversion for COX
-020 -049 -051 ... £6.50
CO₂ Motor Kit ... £8.45
Postage 25p per motor



Racing, Sport & Vintage Engines

NEW ENGINES

| KITS | |
|--|----------|
| 'Scamp' beginner's chuck glider | 85p |
| 'Soarer' Baby' beginner's glider | £2.20 |
| 'Merlin' 33in beginner's glider | £1.85 |
| 'Cadet' 30in glider | £1.79 |
| 'Dragonfly' AI glider | £3.75 |
| 'Petrel' 43in glider | £2.98 |
| 'Mistral' 55in glider | £3.95 |
| 'Caprice' 51in glider | £4.89 |
| Keil Kraft and Verson flying scale range of kits | 92p each |
| 'Pixie' 23in rubber powered | £1.79 |
| 'Achilles' 24in rubber powered | £2.16 |
| 'Competitor' 32in rubber powered | £2.70 |
| We stock Peck & Andrew Moorhouse Peanut kits. | |
| Harry Butler R.T.P. kits and motors | |
| CO ₂ Telco engine kit | £8.45 |
| Telco 18in Cessna kit with engine | £12.95 |
| 'Ocielt' kit for CO ₂ | £3.40 |
| 'Streaker' kit for CO ₂ | £2.25 |
| C/L Trainers | |
| 'Coxbat' for .049 engines | £2 |
| 'Imp' for .049 engines | £1.95 |
| Radian .049 aerobatic | £4.50 |
| 'Scout' for .75-1cc engines | £4.30 |
| C/L STUNT TRAINERS | |
| 'Hot Shot' .09-.15 span 26in | £4.85 |
| 'Junior Monitor' .15-.19 | £5.27 |
| 'Toreador' .15-.19 | £5.83 |
| 'Cobra' .29-.35 stunt | £6.13 |
| 'Marquis' 1cc-5cc 30in | £7.22 |
| 'Lucky Lady' 32in stunt | £5.70 |

| | |
|---------------------------------|--------|
| 'Lovely Lady' competition stunt | £17.50 |
| 'Nobler' 50in competition stunt | £24.00 |
| 'Shark' 45in competition stunt | £18.95 |
| 'Crusader' competition stunt | £14.09 |

COMBAT & TEAM RACING

| | |
|---|----------|
| 'Super Star' FAI combat kit | £5 |
| Super Star plans only | £1.45 |
| Starlet 1-5cc foam combat kit | £3.95 |
| 'Jaguar' FAI combat plan | 85p |
| Excalibur 34in FAI combat | £4.20 |
| Pacifier tanks | 12p each |
| Mustard tin tanks | 40p |
| Ear defenders | £4.75 |
| MM fuel filter | 29p |
| 100ml syringe | £1.45 |
| Baby Blue 1/2 A Goodyear kit | £3.60 |
| Prop by Bartells, Jim McCann, J.B. Fibreglass | |
| Prop balancer | 60p |
| .049 NV & body | £2.22 |
| .049 needle and spring | 88p |
| FAI T/R crutch drazek, A.R.M. | £2.25 |
| FAI Rossi T/R pan | £4.00 |
| SMAE type prop nuts | £1.50 |
| Fibreglass cloth .06oz sq. yard | £1.90 |
| Goodyear wheel | 85p |
| We stock Rossi, S.T. Cox spares listed above is just a small selection of our stock visit our shop or send SAE for full list. | |

C/L ACCESSORIES

| | |
|-------------------------------|-------|
| Roberts 3rd line handle | £6.70 |
| Roberts upright bellcrank | £3.35 |
| Adjustable handle | £1.15 |
| Pr-handle | £1.35 |
| KK handle plastic | 35p |
| DC metal handle | 91p |
| Fox wood/metal handle | £2.42 |
| Sullivan ready made lines | |
| 012in x 52ft | £2.95 |
| 015in x 52ft | £2.95 |
| 012in x 60ft | £2.95 |
| 015in x 60ft | £3.15 |
| Line connectors | |
| Small (pair) | 25p |
| Large (pair) | 25p |
| Line reels 4in | 38p |
| 5in | £1.20 |
| Laystrate lines | |
| 70ft lwt. 3 strand | 54p |
| 100ft lwt. 3 strand | 67p |
| 70ft hwt. 7 strand | 64p |
| 100ft hwt. 7 strand | 83p |
| Foam blocks 36in x 24in x 3in | £3.24 |
| Transformer 28v 2 amps | £6.32 |
| Nichrome wire (per foot) | 5p |
| Valve spout fuel bottle | 75p |
| Sullivan 16oz fuel bottle | £1.20 |
| Tufcote fuel proofers | 59p |

We have a full range of brass and aluminium tubing, Paxolin plates, Dural plates, Solar film, C/L tanks, nuts and bolts, etc.

| | |
|---------------------------|--------|
| E.D. Racer 2-4cc | £12.18 |
| E.D. Super Racer 2-4cc | £13.78 |
| E.D. Super Fury 1-46cc | £9.97 |
| OPS 29 glow 'B' T/R | £47.95 |
| S.T. 46 stunt | £29.81 |
| MVVS D7 diesel | £18.25 |
| Rossi 15 Normale Glow | £42.30 |
| Rossi 15 Normale Glow ABC | £46.20 |
| Rossi 15 FI Combat diesel | £44.50 |
| Rossi 15 RV Team Race | £44.50 |
| Super Tigre X15 ABC | £34.40 |
| Super Tigre G15/19 glow | £24.64 |
| S.T. X21 STD | £36.86 |
| S.T. X29 Speed | £40.38 |
| S.T. X40 Speed | £40.38 |
| OPS 29 Speed ABC | £54.50 |
| Super Tigre X15 ABC | £33.40 |
| PAW 2-49 diesel | £8.64 |
| PAW 19 DS diesel | £9.18 |
| Mabuchi aero motor kit | £10.15 |
| Zom 2-49 diesel | £14.95 |
| Cox Conquest 15 | £45.00 |
| Remco 29 spark ignition | £51.00 |
| Fox 36X Combat Special | £23.18 |
| Webra 2-49D | £14.53 |
| Webra Record 1-49D | £13.31 |
| OTM-8 Diesel | £4.95 |
| Mk17 1-49D | £7.50 |
| Shokol 2-49D | £6.80 |
| PAW 1-49 DS diesel | £8.10 |
| PAW 2-49 Tuned | £11.68 |
| COX .049 TD | £14.50 |
| COX .051 TD | £14.50 |
| COX BLACK WIDOW .049 | £9.65 |
| COX .09 MED | £12.50 |
| COX MED .15 | £19.50 |
| COX .010 TD | £15.00 |
| COX .020 PEE WEE | £8.95 |
| COX .049 BABY BEE | £8.95 |

We buy all types of engines for cash. Send for best quotation by return. Phone for new & secondhand stock position
Barclaycard, Access Phone No. for same day service. Plus Mastercharge, Carte Bleu + Visa.

KINDLY MENTION 'AEROMODELLER' WHEN REPLYING TO ADVERTISEMENTS

SUPER Tigre

THE NAME THAT
STANDS FOR
SPEED & POWER

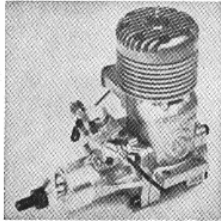

G.60 F.I. R/C £54.71 Retail

| Super Tigre Engines (inc. VAT) | |
|--------------------------------|--------|
| G20/15D | £19.80 |
| G20/15 DR/C | £28.20 |
| *G20/15G | £19.80 |
| *G20/15GR/C | £28.20 |
| *G15 R.V.D. | £30.40 |
| *G15/19 F.I. R/C | £31.05 |
| *G15/19 F.I. | £24.64 |
| G20/23 Std. | £19.80 |
| G20/23 R/C | £28.20 |
| *G21/35 F.I. | £28.53 |
| *G21/35 F.I. R/C | £34.51 |
| *G21/46 F.I. Std. | £29.81 |
| *G21/46 F.I. R/C | £36.37 |
| X21 F.I. Std. | £36.86 |
| *X15 F.I. Std. | £36.86 |
| *X29 Speed | £40.38 |
| *X40 Speed | £40.38 |

| | |
|------------------------------|--------|
| *ST. 35 Std. | £22.66 |
| *ST. 35 S R/C | £29.32 |
| *ST. 60 R/C | £39.00 |
| *G60 F.I. Bluehead ABC | £65.00 |
| *G71 F.I. R/C | £54.71 |
| *G60 RING Blue Head | £54.71 |
| Silencers | |
| S15, fits G20, 15, 19, 23 | £5.41 |
| S29, fits G21, 35, 40, 46 | £5.81 |
| S35 fits ST35S, ST35C, | |
| ST35R/C | £5.81 |
| S40, fits G40 | £5.81 |
| S56, fits ST51, 56, 60 | £5.81 |
| S71, fits G60 FI & RV & G71 | £5.81 |
| Glow plug standard | .74 |
| Glow plug R/C | £1.44 |
| Speed Glow Plug | .96 |
| Needle valves, fit all sizes | .35 |
| Needle valve and spray bar | £1.12 |
| Pressure Nipple | .35 |
| R/C car heat sink | £2.96 |
| Exhaust extension (R/C car) | £1.84 |
| Idle Needle Assy. MAG III | £1.19 |
| Fuel Inlet Section | £1.19 |

*Indicates from stock at Aug. 1st.

To Commonwealth Dealers,
Importers and Wholesalers—
We are the agreed suppliers for
engines and parts. Just drop us a
line for copies of our latest price
schedule & delivery position.



WORLD ENGINES

LIMITED
87 TUDOR AVENUE, WATFORD, HERTS
PHONE WATFORD 42859

VISITORS BY APPOINTMENT ONLY, PLEASE
TRADE ENQUIRIES INVITED S.A.E. WITH ENQUIRIES, PLEASE

WonderWings

The easiest
to build wings in the world



NEW WEMBLEY AEROSTAR 50in. span .29-.45 glows £14.95. New
SUPERSTAR "Competition Special" £5.45. New STARLET II £4.15. All
with hollow foam wings and comprehensive accessories.

THE LAURELS, 3 RACK END, STANDLAKE, OXON

AVICRAFT Ltd. (01-460 0818)

6 CHATTERTON ROAD, BROMLEY, KENT.

MAIL ORDER A SPECIALITY AND A PLEASURE

We take: ACCESS, BARCLAYCARD, H.P., QUADBOND or CASH

We stock all you need for
general control line work.

Kits in plenty

We can get
anything extra you
may need.

SPINNERS/SPECIALISED
ITEMS — TO ORDER

TRY US FIRST

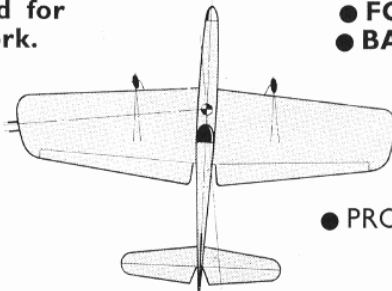

- FOAM WINGS cut to order
- Balsa wood ● HINGES
- SOLARFILM ● LINES
- ENGINES ● WIRE
- GLO PLUGS ● CLIPS
- HANDLES ● NYLON
- ADVEL 10 sec glue
- PROPS ● WHEELS ● COLLETS

Davis Diesel Conversion
head for Cox 049 and 051

WHEN YOU WANT TO TRY RADIO CONTROL

We hold stocks of radio, plenty of trainers, all the accessories,
ready built planes, free advice! We will even arrange for you to
be taught to fly R/C.

KINDLY MENTION 'AEROMODELLER' WHEN REPLYING TO ADVERTISEMENTS

77 CONTROL LINE KITS from RIPMAX

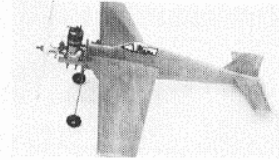

QUEST IMP £1.95
18" span all-balsa profile beginners model for .049 glow or small diesels. Kit complete with horn, bellcrank, tank, etc.



CAMBRIA PROFILE SCALE
Super-complete kits with pre-cut wood and moulded plastic parts, hardware items, etc. 28" span for .09 glow or 1-l-5cc diesels. Each £4.95
HURRICANE ... FW 190 ... ME 109 ... SPITFIRE ... also SCOUT, sleek, speedy 21" span sports/trainer for .75-1cc diesels. Easy to build. £4.30



GRAUPNER DORNIER D027 £16.40
Super 31 1/2" span scale model.
Also 39" span FW 190 £19.90



STERLING CONTROL LINE SCALE
32 1/2" span STEARMAN PT 17 ... £16.65
36" GT LAKES TRAINER £17.50
32" span SESA £15.80
32 1/2" span FOKKER D-7 £15.80
35" span CORSAIR F4U-1 £16.65
33" span NIEUPORT 28 £16.65



STERLING '6-WAY' KITS
Easily convert to control line with small glow motors. Built-up, tissue covered, with detailed plastic parts to simplify assembly.
33" CURTISS JENNY JN4 £9.15
33" span TIGER MOTH £10.80
39" FLYING FORTRESS £13.30
34" FORD TRI-MOTOR £10.00
28" ALBATROSS D111-A £10.00
28" BOEING P26-A £10.00
31" STINSON RELIANT £8.30
35 1/2" span PIPER CUB £9.15
33 1/2" span CITABRIA £8.30
27" P-40 WARHAWK £8.30
23 1/2" FOKKER TRIPLANE £8.30



ALL-BALSA 'BEGINNERS' KITS
Another super range from Sterling to take any 049 glow motor. Pre-cut parts with nylon motor mount ready fitted, complete control system, etc.
21" span RINGMASTER £4.15
21" span MUSTANG £4.15
21" span BIPLANE £4.60
20 1/2" span SPITFIRE £4.15
20 1/2" span PIPER CUB £4.15
20 1/2" span SHOESTRING £4.15
20 1/2" span CHEROKEE £4.15
20 1/2" span THUNDERJET £4.15
20 1/2" span EINDECKER £4.15
20 1/2" span THUNDERBOLT £4.15
20 1/2" span FOKKER D-7 £4.60
20 1/2" span HELLCAT £4.15
20 1/2" span FW190 £4.15
20 1/2" span ZERO £4.15
20 1/2" span ME109 £4.15



STERLING



PROFILE SCALE AND STUNT C/L
For stunt, combat or 'Sunday flying'. Die-cut and shaped parts plus hardware, etc. For engine sizes shown in brackets.
42" RINGMASTER (19-35) £10.80
38" P-51 MUSTANG (19-35) £11.65
40" YAK-9 (19-35) £10.80
30" RINGMASTER (09-19) £7.45
21" RINGMASTER (02-049) £4.95
36" LIGHTNING (09-19) £11.65
52 1/2" SPITFIRE (29-35) £24.20
34" FLYING FOOL (19-35) £11.65
42 1/2" span WINDER (35) £8.30



LARGER SCALE MODELS
The following super-detailed Sterling scale R/C kits are also designed to adapt for control line.
58" STINSON RELIANT £45.90
57" span WACO S.R.E. £54.25
64 1/2" STEARMAN PT-17 £66.75
40 1/2" span SESA £33.35
58 1/2" span FOKKER D-VII £62.60
58 1/2" PIPER TRIPACER £26.70
48" FAIRCHILD PT-19 £20.00
70" span KING COBRA £48.40
66" span F-51 MUSTANG £54.25
54" PIPER CUB J-3 £20.00
64" span SPITFIRE £54.25
54" span CITABRIA £30.85
72" PIPER SUPER CRUISER £40.00
45" span CESSNA 180 £16.65

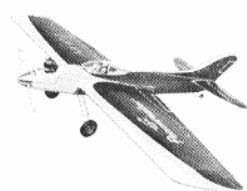

TOPFLITE CONTROL LINE
46" PEACEMAKER (15-35) £15.40
50" span NOBLER (19-35) £24.00
40" JR NOBLER (15-29) £13.45
42" FLITE STREAK (15-35) £12.50
31" JR STREAK (09-29) £9.15
24 1/2" BABY STREAK (049-09) £4.80
42" COMBAT STREAK (19-35) £11.10

TOPFLITE J-A PROFILES
All 18" span for .049 engines SPITFIRE MUSTANG and LANCER each £3.80

TOPFLITE 'SUPERFORM' KITS
Exact scale models featuring formed balsa fuselage shells, formed landing gear, canopy, etc., etc.
37" span P-51D MUSTANG ... £25.00
27" P-47 THUNDERBOLT £17.30
28" span P-40 WARHAWK ... £17.30

24" span JUNIOR ACES
Profile models for .049 engines. MUSTANG HURRICANE COSMIC WIND each £5.75

TOPFLITE FORMFLITE SEMI-SCALE
Pre-moulded balsa fuselage shells with conventional wing and tail construction. For .15-35 engines.
42" span P-40 TIGER SHARK ... £13.45
42" span HAWKER HURRICANE ... £13.45

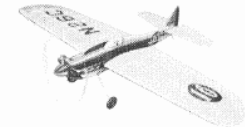

GOLDBERG C/L KITS
Noted for their fine quality materials, excellent design and performance — and extensive prefabrication for easy assembly.
21" L'IL WIZARD (049) £5.35
19" L'IL SATAN (049) £4.45
29" JUNIOR SATAN (19) £5.35
18" P-40 (049) £4.95
43" P-40 FLYING TIGER £12.55
18" SWORDSMAN (02-049) £4.95
42" SHOESTRING (19-35) £10.75
36" RILEY WOOTEN VOODOO £6.25
16" LITTLE TOOT (049) £5.35
21" L'IL JUMPING BEAN £4.95
43" COSMIC WIND (19-35) ... £10.75
40" BUSTER (19-35) £10.75
23" STUNT MAN (049-09) £5.35

ENGINES & PROPS

There's an engine in the RIPMAX range to match nearly every one of the 77 models listed ... ME (diesels) ... ENYA ... MERCO ... AUSTRORWEBRA ... HP ... GRAUPNER HB ... plus a complete range of Silencers, and engine accessories including PROPS by TORNADO ... TOPFLITE ... RIPMAX ... GRAUPNER ... KAVAN ... IP.

MODEL TECHNICS MOLECULAR BLENDED FUEL
The world's largest and finest range of GLOW and DIESEL FUELS to enable you to get the best out of your engine! Ask your model shop for the MODEL TECHNICS LEAFLET.

plus ACCESSORIES

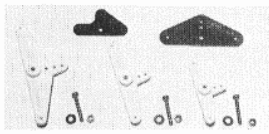

RIPMAX-MK NYLON BELLCRANKS
2" 32p 2 1/2" 36p 3" 45p
RIPMAX PAXOLIN BELLCRANKS
Small 4p Large 5p
SCHLUTER GLASS FILLED NYLON BELLCRANKS
180° 28p 90° 28p



RIPMAX POLYPROPYLENE HINGES
Small (pkt 18) 30p Large (pkt 18) 35p
GRAUPNER NYLON HINGES: (pkt 20):
Flat £1.50 Capped £1.10 Top-edge £1.10
One-piece Poly Hinges 85p
KAVAN NYLON HINGES (pkt 10)
Flat 36p Mini 72p
also a wide selection of CONTROL HORNS.

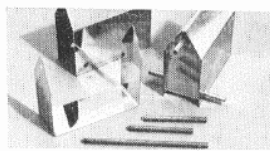

RIPMAX 'SOLDERTITE' TANKS
Lowline stunt wedge, ready-made or in kit form.
SMALL 42p (kit 24p)
MEDIUM 50p (kit 30p)
LARGE 55p (kit 35p)
EXTRA LARGE £1.10 (kit 50p)
also ranges of KLUNK tanks.

LAYSTRATE STRANDED WIRE
The original, and still the first choice where you want kink-resistant lines.
LIGHTWEIGHT 70ft 54p
HEAVYWEIGHT 100ft 67p
HEAVYWEIGHT 70ft 65p
100ft 84p
'REDLINE' FUEL TUBING
6 sizes, from 3p per ft.

DE LUXE FIELD BOX
carries all you need on the flying field — fuel, starter battery, etc., and complete with separate tool drawer £13.50

NOW AT YOUR LOCAL MODEL SHOP

KINDLY MENTION 'AEROMODELLER' WHEN REPLYING TO ADVERTISEMENTS

FOAM FOR ALL

BY RICHARD WILKENS

IF YOU stop and think about it, built up balsawood wings are rather pointless. You trek back from the model shop clutching those nicely sawn planks of balsa, only to spend all your spare time cutting them up into little pieces, and then gluing all those little pieces back together again, albeit in a different shape. Then you have to buy material such as nylon and dope to cover the wings. All of this naturally adds to the expense – not to mention the time taken.

Conversely, wings made of polystyrene foam just require cutting to the required shape, then covering with (very cheap) paper. The result is a consistently lighter structure (wood varies enormously in density – foam does not), very quickly made and easily finished. Do not be put off by the alleged difficulty of working with foam. It's a fallacy – no skill is required!

The principle of forming a wing is very simple – a hot wire cutter is used to melt the foam as it passes around a pair of templates placed at either end of the block you are cutting. The expanded polystyrene foam is very easily obtained from insulation contractors and building suppliers and is sold in 2in thick 8ft × 4ft sheets, or smaller offcuts may be available.

The foam itself is cut by means of the previously mentioned hot wire which is held under tension in the very simple cutting bow – see *Figure 1*. Success in cutting foam properly depends on the following factors:

(a) *Tension of the hot wire.* This can easily be adjusted by varying the number of rubber bands on the hot wire bow's frame. Tension should be as high as possible without stretching the hot wire.

series should be used so as to provide the 20–24 volts often required to heat the nichrome hot wire cutter. Even better is to use a mains operated variable transformer, sometimes called a volt slider or Variac, but these cost in the region of £20. Incidentally, although 7-strand Laystrate control line wire can be used for the cutter wire, it is far more susceptible to heating and cooling fatigue than nichrome, and will consequently not last nearly as long.

The temperature of the hot wire is thus varied by increasing or decreasing the voltage passing through it. Should the voltage be too high, grooves will be burnt in the templates if they are made from ply or card. The surface of the wing becomes rougher and the speed of the cut is more critical because if you stop moving the wire, a bigger groove is melted in the wing surface. Should the temperature be too low, then the wire will drag too much in the foam and cause the mid point of the wire to cut a different section from that of the templates – see *Figure 3*. The leading edge guide shown helps reduce this effect, but the worst thing you can do is to go round one template before the other. This damages the leading edge shape between templates.

(c) *Speed of cut.* This is determined by the temperature of the cutting wire. If you pull the bow too hard, the wire drags as shown in *Figure 3*, but if you pull too slowly, the wire burns the template or melts a groove. The answer is to practice and to move the bow as slowly as possible to give the best surface finish.

(d) *Smoothness of template.* Formica templates are the smoothest and give greatest ease of operation. A rough template will cause the wire to catch or stop momentarily,

Figure 1
The hot wire foam cutter

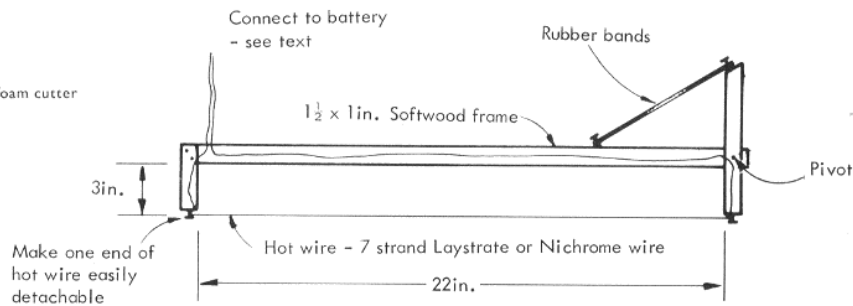

(b) *Temperature of the hot wire.* The most convenient power source for heating the cutting wire is a 12 volt car battery. 12 volt car batteries have six 2v cells which are connected to each other by lead strips that are situated just below the top surface of the battery casing. If you examine the top of the battery you may find drilling points marked which are used by battery dealers who drill down to the lead strips enabling them to test the individual 2v cells. Should you not be able to find those marks, consult a dealer as to where to drill. After drilling holes and inserting screws into the lead strips you may tap off 4, 6, 8, 10, as well as 12 volts for the hot wire by the use of crocodile clips fitted to the hot wire leads. Smear plenty of Vaseline round the screws to prevent corrosion. For best results, a couple of car batteries connected in

melting a groove in both the wing and the template itself, if it is made from wood or card.

WING PRODUCTION

To produce a wing, two templates for the airfoil section must first be produced – remembering to include the extensions to guide the hot wire at the front and back. The templates can be made from a variety of materials, namely:

- | | |
|------------------------|---------------------------------------|
| (a) Dense thick card | suitable for prototypes or 2–6 models |
| (b) 1/8 in thick ply | a bit better than above |
| (c) 1/16 in thick ply | suitable for around 50 models |
| (d) Formica | fine for hundreds of models |
| (e) 1/16 in mild steel | infinity? |

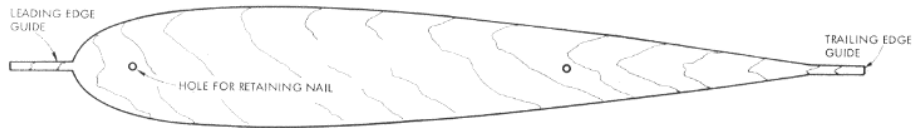

Figure 2— Typical wing template. Use nails to fix to either end of foam blank. When cutting the foam, place the blank between wooden stops screwed to the workbench and then place a book or similar large heavy object on top of the blank to keep it firmly in place. You need both hands to operate the hot wire cutter.

Materials a), b) and c) will be damaged if the hot wire pauses for more than a second, although if a notch is burnt into a template, it can easily be sanded or filed smooth again, albeit at the expense of the wing section's accuracy. For combat models, that probably will not matter too much, but stunt enthusiasts may be fussier!

The basic block of foam should be held down securely with the templates held at each end – a couple of nails apiece will hold them quite satisfactorily. Be careful to align them one to another if the wing is to be a basic rectangular plan form, or to position the tip rib template in the correct relative position to the root chord template if a tapered wing is desired.

Having already practised with the bow and established the correct settings previously described, cut the wing, working from the leading edge to the trailing edge, as this gives a better shape to the all important leading edge. Cut the top piece first. Make sure that the bow passes over each template at the same rate, so that with a tapered wing the wider root chord is traversed more quickly than the tip, in order to start and finish the cut at the same time.

Easy, wasn't it? Now for something just a shade more complicated. Remember, while foam is light, holes are even lighter! Unfortunately holes can be weak unless placed with care – the answer is to use suitable templates to cut 'voids' from the wing blank. Using wing templates, the voids are placed exactly where you want them, leaving a sufficiently strong central beam at maximum rib depth for strength and leaving a 'skin' thickness as required. At the same time as the voids are cut out, it is also convenient to form the surface-spar slots using the same template as shown in *Figure 4*. The procedure is much as before, but the voids are best cut before the airfoil itself. This means that the hot wire must first be passed through the centre of the foam block, so a hole is formed to allow this, using the jig shown in *Figure 5*.

Starting with a rectangular block of plastic the correct size, nail the spar slot and void templates to the block, then rest the block on the notched plate on the hole making jig and melt a hole through each wing void by

PLAN VIEW

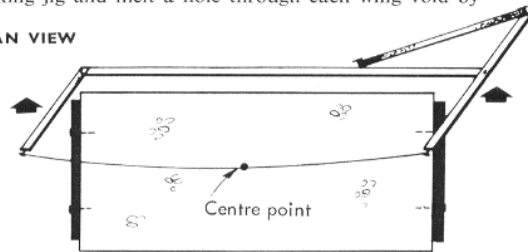
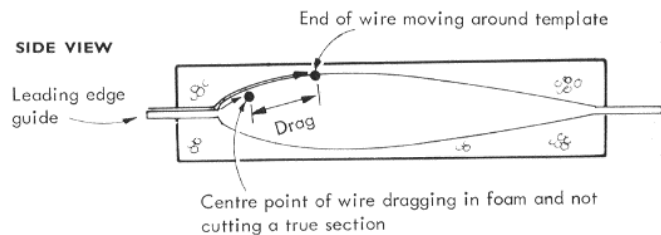

Figure 3 — Cutting wire too cold, or too slack

SIDE VIEW



heating the 10 swg wire rod to almost red heat with a blowlamp and dropping the hot rod through the wing. The wire loops in the hole making jig must be 1in above the plank face to ensure that the wire drops accurately through the plastic and exits through a hole in the lower

CAUTION . . .

Do not use a template without a leading edge guide (as shown in *Figure 2*). Without this device it is most likely that one end of the hot wire will not go around the template before the other, thus distorting the wing leading edge.

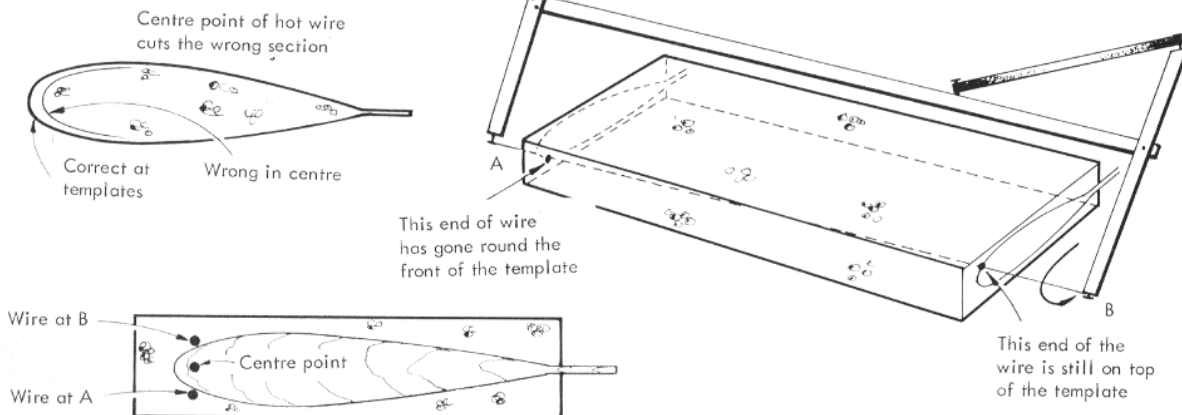

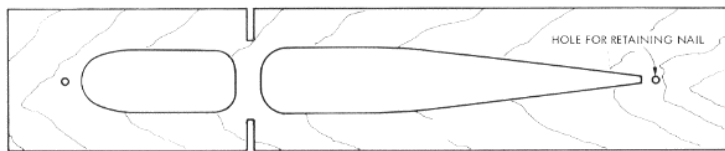

template. When both holes have been melted, the spar slots may be cut with the hot wire shown. The wings are hollowed out by disconnecting the wire from one end of the hot wire frame and threading it through one of the melted holes that you have made. Pull the hot wire through the hole with a piece of 20swg piano wire. Re-connect the hot wire to the frame and switch on the power. Run the hot wire round the template holes and then back to the melted hole. Switch off the power. Disconnect the wire from the frame, extract the hot wire and plastic from the wing panel and repeat the procedure for the other voids.

When the spar slots and lightening holes have been made, remove that template and nail the airfoil template in place, using the same nail holes, then cut the airfoil shape.

CUTTING WING TIPS

Forming wing tips is also very easy, but here a slight change of technique is required. Tips used on the *Super Star II and III* models are much more efficient than those used on conventional structured combat models and offer a worthwhile reduction of induced drag. To make them, a different hot wire cutter is required, but it is even more simple than the bow cutter already described.

As can be seen from *Figure 6* the principle is that one end of the cutter is fixed, whilst the other end is hand held and drawn around the tip template nailed to a suitably sized foam blank. Naturally the pivot must lie on the same centre line as the tip template. Just switch on the power (6-8 volts should be about right) and pull on the handle to keep the tension constant.

If you prefer an elliptical shape on your model, then the solution is to use a 'Kipper' - it makes an all foam Spitfire wing quite simple. This kipper (*Figure 7*) should be made from $\frac{1}{8}$ in ply or Formica and should represent the plan form of both left and right hand wing tips

At right are 'before and after' pictures of a void template in use. Note that on this occasion the airfoil was cut first - hence the locating blocks on the template. Below is a further development now being used. The wing will feature an internal full depth spar, and to save the necessity for forming a hole in the blank to take the hot wire when cutting the void, the rear of the template is split. Thus cutting the void is one quick easy manoeuvre - although of course the trailing edge will need gluing together later.

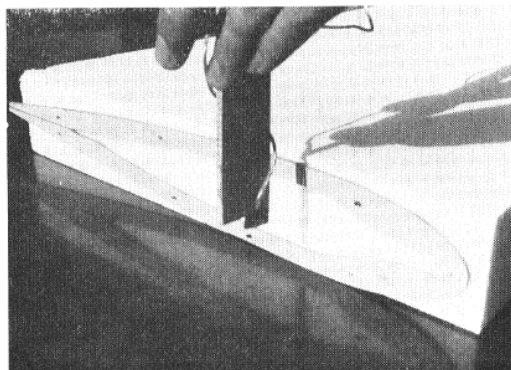

Figure 4▲ Template for cutting voids and surface spar slots. Use different templates at tip and centre to provide lighter tips if desired.

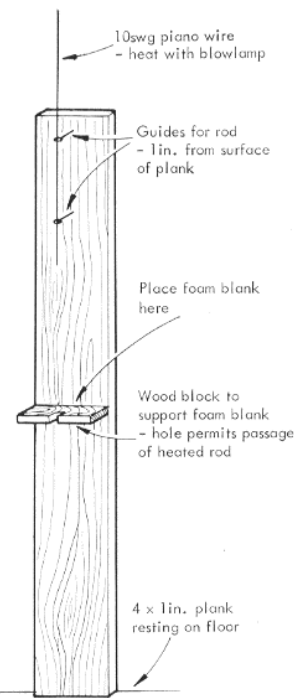
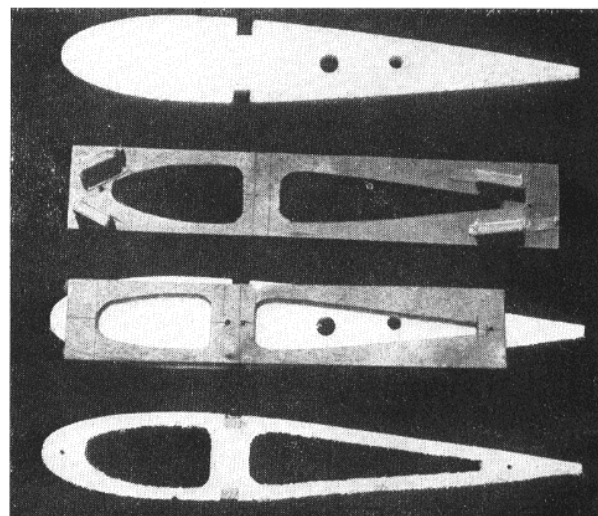

Figure 5▶ Jig for forming hole in foam blank for passage of hot wire when cutting voids.

joined together. Along the centre line, glue on at right angles a template representing half of the desired airfoil. Lay a slab of plastic on the kipper, then with the edge sticking out over the table, run the hot wire cutter over the half rib section and around the tip, keeping the wire at right angles to the rib section. The result is an instant half wing tip. Reverse the kipper and produce another half tip, then glue either side of a balsa plate, which adds strength and also carries the leadout guides.

GOLDEN RULES

Now that you have cut out your foam components, it is time to bear in mind a few words of caution before



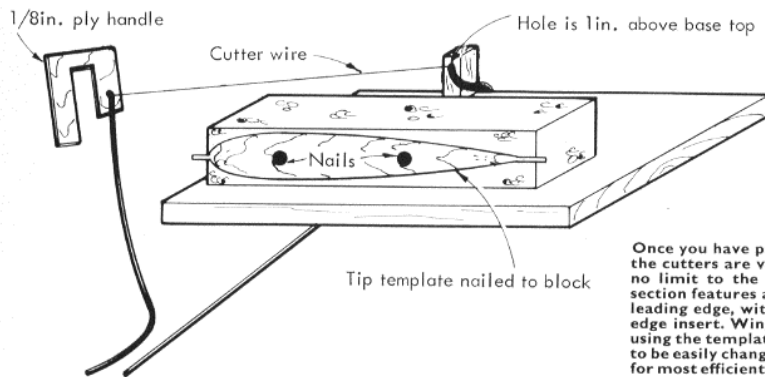

Connect to battery - see text

Figure 6 ▲ Using a special jig and cutter to form wing tips for combat models.

Once you have practised the technique of cutting foam - and all the cutters are very simple, quick and cheap to make - there is no limit to the variations you can try. This ultra light wing section features a full depth balsa spruce spar set back from the leading edge, with 'I' beam sections of foam and spruce trailing edge insert. Wing was formed in two halves (top and bottom), using the templates shown and this enabled the sizes of the voids to be easily changed - from small at the centre to large at the tips, for most efficient utilisation of strength and weight. Now stretch your imagination . . .

joining them together with the (very few) pieces of wood necessary for building a complete aircraft.

FOAM SOLVENTS: Do not let dope, dope thinners, balsa cement, plastic cement, Evostick or Bostic contact adhesives, glass fibre resin, cellulose based fuel proofers and paint, 'Hot Stuff' or 'Zap' glue, glow or diesel fuel come into contact with the polystyrene - they melt it.

SUITABLE GLUES: Use only white woodworking glue such as Evostick, Borden, PVA, Sig Bond or any 5 minute epoxy for all joints. Use adhesive tape to hold joints together while the glue sets. Do not put tape along the entire length of a white glue joint because air must get to the glue so that it can set.

CUTTING: Foam may be cut with a **VERY SHARP** knife or razorblade, hot kitchen knife or hacksaw blade, a hot wire (as described) or a rotary bread slice. Do not use a Burgess band saw with a toothed blade because plastic saw dust clogs the groove in the lower blade guide and eventually the blade jumps the guide.

SHAPING: Use a razor plane with a sharp blade. Medium glass paper. Use fine glass paper or grade 360 silicon carbide paper for final sanding. Use scrap foam for the sanding block.

TESTING: Test any other type of glue or paint and practice cutting or melting holes in the plastic on a scrap piece of plastic first before trying it on the model.

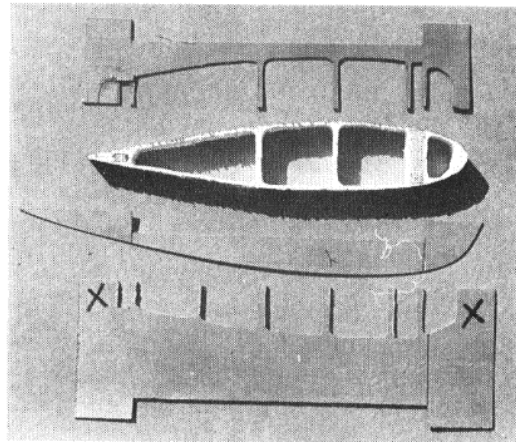

LOCAL REINFORCEMENT: Nylon strip is often used as reinforcement on combat wings and this should be added before covering the model. To do this, mix 8-10 teaspoonfuls of white glue with an equal amount of water, brush the mix onto the foam, add the nylon and give another coat of the mix, excluding all air bubbles.

continued on page 71

Figure 7 Using a 'kipper' to form elliptical tips

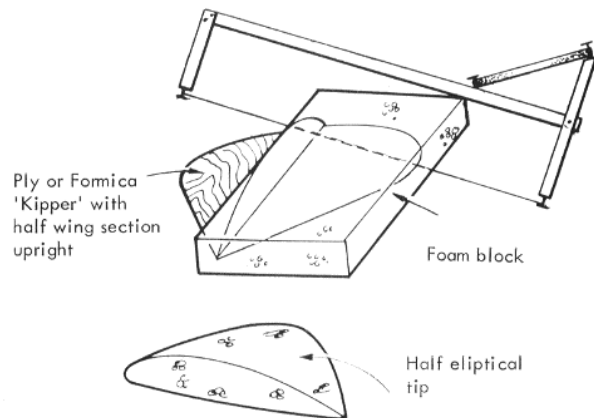
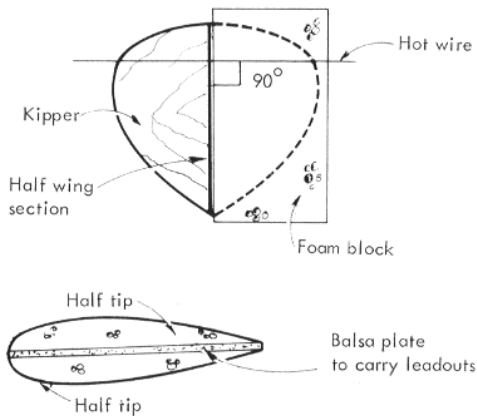

TRIMMING PROCEDURES FOR STUNTERS

BY JOHN NEWNHAM

The author, a regular member of the British stunt team, poses with his Shadooie design - unfortunately this model was written off just two weeks prior to the 1977 European Champs., requiring a lot of midnight oil to be burnt building a replacement - followed by a full trimming session, using the methods described in this feature.



IT WAS about ten years ago, the 1967 National Championships to be precise, when I took the plunge and entered my first control line aerobatic competition. I still recollect the occasion quite vividly; battling against the elements to get through the schedule and losing line tension in practically every manoeuvre! I just could not understand how those experts' models handled the conditions so well when mine seemed to be fighting every inch of the way.

Some considerable time (and models) later, it was a chance remark that put me on the right track and started me thinking about a whole new aspect of aerobatic flying. This remark, which was made after yet another of my rather 'hairy' flights, drew attention to the fact that in normal level flight, my model was flying with its outboard wing tip low. When asked if I had trimmed the model, my first reaction was to laugh: who was this funny guy passing sarcastic comments on my aeroplane's free-flying tendencies? Surely control line models either flew 'straight off the board' or not at all! But no, he was serious - you really can and do have to trim a control line model to get the best performance out of it, and I soon realised that the preparation of the model is just as important as that of the pilot.

From that day on, I have thought a great deal about preparation and trimming procedures and over the years I have evolved a formula that I follow religiously with each new model. In the following paragraphs, I have attempted to itemise the various aspects of trimming and to explain the importance of each. I am not an aero-

dynamicist and I do not pretend to be an expert in such matters. My arguments tend to be based simply on common sense and practical considerations.

As with any other branch of aeromodelling, the success or otherwise of a model begins on the building board. Although it is possible to trim a warped model to fly reasonably well, there is no substitute for accuracy of construction. Particular attention should be paid to all the alignment stages i.e. wing/tailplane/engine thrust line (zero incidence), elevator/wingflap junctions (squareness in both plan and front elevations). It is while the model is still in the construction stage that a number of useful features can be incorporated that will help tremendously in getting the most out of the trimming phase. These features include: adjustable wing tip weight, variable lead-out positions, provision for adjusting the centre of gravity (e.g. a weight box near the tail of the model), a method of adjusting the relative neutrals of elevators and wingflaps (usually accomplished by simply bending the flap and elevator joining wires), and, ideally, some means of adjusting the ratio of flap to elevator deflection.

So, after much toil and sweat, the day arrives when you are able to display your new model proudly and you are just itching to get it to the flying field and give it a whirl - well, don't! In fact much of the 'trimming' procedure can be carried out before ever the model leaves the workshop.

The first checks to perform, after assembling the model, are those of wing, tail and thrustline alignment. These are simply achieved as shown in *Figure 1*. Set up the model on a smooth, level surface (your building board should

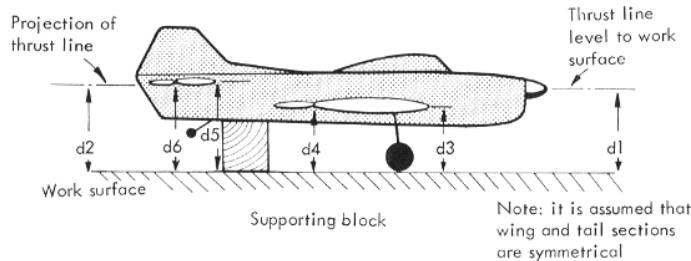

Figure 1 - Checking alignment

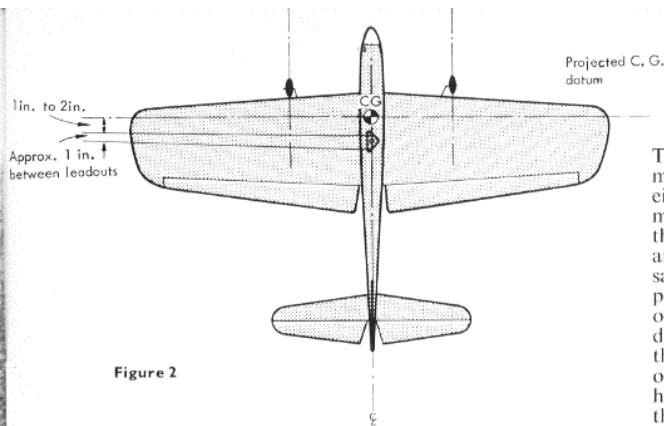

Figure 2

meet this specification!) with a suitable block under the tail end so that the thrust line is parallel to the surface (i.e. $d1 = d2$). Now measure accurately the dimensions $d3$ and $d4$; they should not differ by more than $\frac{1}{16}$ in. If they do, there is a strong possibility that in order to get the model to fly straight and level, you will need to incorporate so much 'down' or 'up' trim that a satisfactory final trimming will be difficult to achieve. If your model is of the two piece variety, an adjustment to the wing mounting should not be too difficult. If, however, it is one piece, all I can say is that you should have built it more accurately in the first place! Similar checks may be carried out for the tailplane by comparing dimensions $d5$ and $d6$.

Other points to check whilst still thinking about alignment are: elevator/flap neutral settings, engine sidethrust and fin offset. Some people prefer one or two degrees of engine offset to aid line tension and others do not think it necessary, but whichever you prefer, be sure there is no sidethrust *into* the circle. A certain amount of fin and/or rudder offset is usually built in during construction and this is not normally a critical factor. However, there are a number of top international flyers who believe in making this an adjustable feature to be set on the initial trimming flights.

The next item on the agenda is the wingtip weight which I prefer to make adjustable. Mine is constructed in the form of a small plywood box, with removable lid, into which the desired quantity of weight may be put. The final quantity of ballast required is not determined until flight testing, but as a safe starting point, add sufficient weight (lead shot is ideal) to make the outboard wing obviously heavier than the inboard. Check this by balancing the model between spinner point and extreme rear of the fuselage and ensure that the outboard wing falls. Do not overdo it, but be satisfied that you have added enough weight.

The usual centre of gravity test of the complete model comes next and this should be carried out with all accessories attached, i.e. propeller and its retaining nut, spinner, silencer, needle valve, tank and all connections.

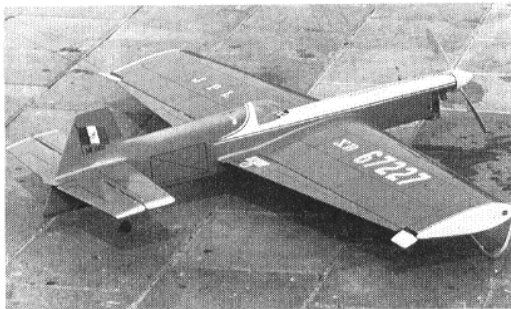

AEROMODELLER

The easiest way of performing this check is to invert the model (assuming a low wing design) and place a finger tip either side of the fuselage on the wing, adjusting until the model balances in a level attitude. The exact position of the CG is not critical at this stage and you should simply aim at producing a model that is safe to fly, while at the same time not being too sluggish. I usually accept a position of somewhere between 5 per cent and 25 per cent of the root chord measured from the leading edge. A well designed model should fall within these limits 'straight off the board', but should you require any ballast, it is obviously better to have a model that turns out to be nose heavy rather than tail heavy, as a quarter ounce added to the tail (a moment of typically 25 to 30in) has a far greater effect than a similar weight in the nose (typically a moment of only 10 in).

So now, at last, you are almost ready to take your new machine to the flying field, but before you do, there is just one more check to perform and that is the initial setting up of the leadout positions. If you have not built in any adjustment here, then obviously you have no choice, but for those who have, I recommend the method shown in Figure 2. Either balance the model with one finger at each wing tip or, if this is not possible, project the CG position to the wingtips, as shown, and adjust the front leadout to exit approximately 1 to 2in behind this point. The two leadout wires should exit as close together as possible – preferably one above the other and no more than an inch apart. The final leadout position will be set after flight testing, but the above procedure should produce a 'safe' model. That concludes the initial setting up; the next move is to run through a number of pre-flight checks before that all important first hop!

Let's start with the fuel tank. This is an item that is quite often taken for granted, but obviously plays a very important role! Having gone through a period of building models with fully enclosed tanks, only to have them leak long before the models had come to the end of their useful life, I now always make them fully accessible and removable. This not only enables the odd leak to be repaired easily, but also allows minor adjustments to the tank position to be made, which leads us to the first check – ensure that the centre line (fuel pick up level) of the tank lines up with the engine spray bar. This should give a consistent and even motor run both upright and inverted. If your tank is moveable, pack it securely in the correct position. The next move, while still at the front end, is to select a suitable propeller. This is very much an individual choice, but in my experience with a .35cu in size model, it usually ends up being either a 10in \times 5in or 10in \times 6in. I tend to start with a 10in \times 6in to keep the flying speed up and then reduce to a 10in \times 5in if I think the model is too fast. If you are following the latest trend and have built a .46 size model, there seems to be a wider choice – anything from a three bladed 10in \times 6in to a 12in \times 6in. All I can say is, if you have any previous experience to call on, use it – if not, then any of the sizes mentioned here should be acceptable for the first few flights. You can experiment later to find the optimum.

While you have the model on the ground with no lines attached, give it a gentle push forwards and ensure that it tracks straight or slightly to the right (assuming your models circulate in the anti-clockwise direction!). It would not be very pleasing if, on its first take off, the model headed straight for you in the centre!

The Nobler is a perennial favourite - this example hailing from Mexico. The trim tabs at the end of the aileron indicate a warped wing and are rather a 'bodge'! There is no substitute for a truly 'straight' wing - so stage one depends on you and your building board.



Two Dutch aerobatic fliers who are regular visitors to World and European Championships - as well as the British Nationals - are Paul Tupker (left) and Peter Van Doesburg. Paul has 'coached' Peter over the years until the pupil now often beats the teacher!

The next problem is what lines to use? From experience I have found that most people flying 35 size models tend to use lines approximately 58 to 60 feet long, with the larger 46 size model using a slightly greater length. Any lines of these approximate dimensions should be acceptable for the first flights, but if you want to play safe, then use the shorter size. Make sure you use lines of adequate cross-sectional area. Light Laystrate is acceptable up to .40 cu in motors and 0.015in diameter Sullivan (Pylon) lines suit all but the largest size of model and are certainly all right for a .46. Do not forget to ensure that your lines are of equal length, or at least that any discrepancy can be taken up at the handle adjustment.

At this stage, you are almost ready to go, but it is always worth running a tank or two of fuel through the motor before flying, to enable you to make sure the supply line is not blocked and to check for consistent running in all model attitudes. You can also take this opportunity of timing the length of the engine run, you do not want to be in the middle of an overhead eight when the motor cuts!

Well that's it then, you cannot put off the dreaded moment any longer; it's time to check all line terminations, give the complete system a pull test, fill the tank and go. On the first couple of flights, concentrate on getting the feel of the model: does it seem to want to turn? Is the engine run a reasonable one? If you are satisfied with these basic points, try a loop followed by some inverted flying and make sure that a) the engine keeps going (nasty if it doesn't!) and b) there is no vicious tendency for the model to roll up the lines or lose all line tension at the top of the loop. If all is well, the real trimming operations can commence.

Begin by flying a number of laps of normal level flight followed by a number of laps inverted and observe the model carefully. If there is any tendency for the outboard wing to appear low, or high, with respect to the inboard wing then the model requires trimming about the roll axis. If you have built your model with trimming in mind, then it should be a relatively simple matter to adjust the neutral position of one flap without disturbing the other. This is most easily accomplished by having the flap coupler made of a material that is capable of being twisted (a 14 or 12 swg cycle spoke is ideal-not piano wire). Thus by grasping both flaps near the root, with thumb and forefinger covering the area where the joining wire is anchored and firmly applying a twisting force, the amount of trim required may be introduced.

In *Figure 3(a)* the model is shown in normal level flight with the outboard wingtip high, and in *Figure 3(b)* the same model when inverted flies with the outboard

wing low. The corrective action to be taken in this case is shown in *Figure 3(c)* i.e. the outboard flap neutral position should actually be slight 'up' flap with the inboard one at a true neutral. The opposite corrective action should of course be taken if the model characteristics are reversed. Be very careful how much trim you introduce at a time - $\frac{1}{4}$ in at the trailing edge of the flap has quite a noticeable effect. If your model should fly with the outboard wingtip low when both upright and inverted, then you have far too much tip weight, but this is extremely unlikely as it is possible to fly with quite high tip weights without any noticeable 'droop' and with the added bonus of good line tension. The opposite effect of course means that you have not added sufficient ballast. I will be covering tip weight adjustment later.

Having got your machine flying more or less on an even keel it is time to investigate its looping properties a little more accurately i.e. to trim it along the pitch axis. Begin by trying a number of inside loops from the level flight attitude, followed by some outside loops from inverted.

Figure 3

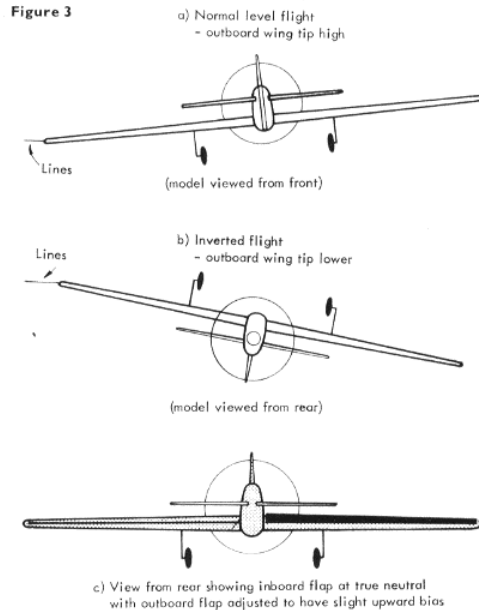

Geoff Higgs, a noted British stunt designer several years ago, now resides in Canada and in 1976 represented that country at the Dutch World Championships.

The first point to be sure of is that the model will complete loops of an adequate tightness. Assuming that you have sufficient elevator and flap movement (45° each way is usually considered adequate) it is possible that you may need to adjust the centre of gravity position. Be careful not to move it too far back, however, as this can easily produce an oversensitive model that is difficult to fly smoothly.

When you are satisfied with the CG position, repeat the loop tests and this time look for differences between the inside and outside loops. Has it got a tendency to perform inside loops tighter than outside or vice versa? This effect can sometimes be quite noticeable, for instance on performing the first few loops you may observe that the model has a tendency to pull out high (tighten up the loop), whereas on an outside loop it needs that little extra bit of movement to pull it round. This example indicates that the model has a certain amount of up-trim built into it, and this obviously needs to be removed if accurate, symmetrical manoeuvres are to be easily flown.

I personally use a similar method of pitch trim adjustment to that outlined earlier for the roll axis correction, but this time adjusting the position of both elevators relative to the flaps. If you are using the bending technique you will need a helper to hold the flaps firmly (in the right place!) while you grasp both elevators and push in the appropriate direction – but do be careful and take care not to overdo it.

Trimming about the remaining axis – the yaw axis – is really a matter of getting your line tension right. I use adjustable leadouts to give the right sort of feel (pull) of the model in level flight. If you have adjustable rudder offset you can also use this to set up line tension. You may well find, however, that further adjustments will be required as a result of variations to other parameters (such as tip weight) but more of that anon.

Well that about completes what I call the 'basic' trimming procedures. By now you should have a reasonably stable model whose characteristics you are beginning to get used to, but you are not finished yet! For instance, what happens to the model in square corners? It may perform beautifully smooth round manoeuvres, but what is that peculiar twitch everytime you do a square pull-out? You will obviously have noticed that some models turn more sharply than others – just a matter of where they balance you might say, but if you have incorporated an adjustable flap horn, or similar, you can actually control the smoothness of your square corner by adjusting the elevator/flap deflection ratio. Basically, the greater the flap deflection compared to that of the elevators, the smoother and wider will be the corner. So a 1:1 elevator /flap ratio gives larger, smoother corners than say a 3:2 ratio would give.

So, to put this into practice, try flying a number of inside and outside square loops and look carefully at what happens in the corners – particularly when the model has slowed up somewhat from its normal flight speed e.g. the corner following a vertical climb. If there is any tendency for the tail to kick or overshoot (the model appears to pivot about a point in the fuselage rather than fly around a smooth radius) then the amount of flap travel for a given elevator movement should be increased. It should be noted, however, that there is usually not much point in going above a 1:1 flap/elevator ratio i.e.

Driving force behind CLAPA, the British association for control line pilots (see address on 'The Specialists' page) is Ted Fowler – seen here with his own design model, featuring Super Tigre 46 power.



flaps having a greater deflection than the elevators.

If your model suffers from the reverse condition – corners of too large a radius – you should try reducing the flap movement for a given angle. Moving the CG rearwards also affects this trim, of course, but I have found that you get a much smoother model by keeping the balance point reasonably well forward and relying on more powerful elevators to get you round. Hence the general trend for longer tail moments.

The final trimming adjustment is that of the wingtip weight, which in my opinion plays a particularly important role. I use the following method to determine how much weight to add. Perform a number of vertical wing-overs with reasonably low, sharp pullouts and observe what happens in the pull-outs. One of three things should occur. Either the model will pull out with wings absolutely horizontal without any rocking (and roll-ing?) motion at all, (as is more likely) the outboard wingtip will either sag below the inboard tip level or appear higher than it.

The remedy is simply to subtract or add weight respectively. It is interesting to note, however, that models do not seem to be particularly sensitive to this adjustment and it is possible to add quite a considerable quantity of weight before 'tip sag' is detected. It has even been known for some flyers to produce models with the outboard flap longer than the inboard (or at least flaps of equal size on asymmetric models) so that they can add more tip weight. By increasing the tip weight in this fashion it is possible to produce a model that will perform a schedule noticeably

continued on page 19



ON THE LINE

BY STEVE BLAKE

A GOOD model and engine are of little use if they are not flown using correctly made up control-lines. These fall into three main types. Firstly, for small models (see chart) thread can be used. However, a few words of caution are necessary. The best type of thread is waxed linen – Keil Kraft *Supercord* is ideal, and available from your model shop. Do not use monofilament nylon fishing line or light terylene cord – both stretch too much to give positive control.

Secondly, single strand steel wire lines are available in a variety of diameters and are very reasonably priced. However, they are tricky to handle and liable to kink unless great care is taken (see below) and are generally only used by those interested in the team racing or speed classes, where the experts appreciate the finer control and better speed they produce. The last type of line and certainly the most widely used, is the stranded steel variety. This is available in a wide range of sizes and number of strands to suit all classes of flying. *Figure 1* shows the correct type of line to choose to suit your model and engine.

Making Up a Set of Lines

Thread lines present the least problems. Place your model on the ground and accurately measure the desired line length. Make a loop in one end of the line (*Figure 2*) and unroll the thread until the handle is reached, when a second loop is made, completing the first of the two lines. The accurate length of this line is not critical, it is merely necessary to make up the second line to match the first exactly. Of course it is a great advantage to use a control handle that allows a reasonable range of adjustment, as this avoids repeatedly remaking the line ends to get a pair of exactly matching length.

The making up of a set of steel lines presents several problems not encountered with thread. Firstly, single strand wire *can* prove near impossible to remove from the card upon which it is packaged! The solution is to cut off the heat shrink wrapping with a sharp blade, then remove all but one of the cotton binding pieces which holds the coils together. With an assistant holding the free end, revolve the coil, paying out the line by sliding the binding

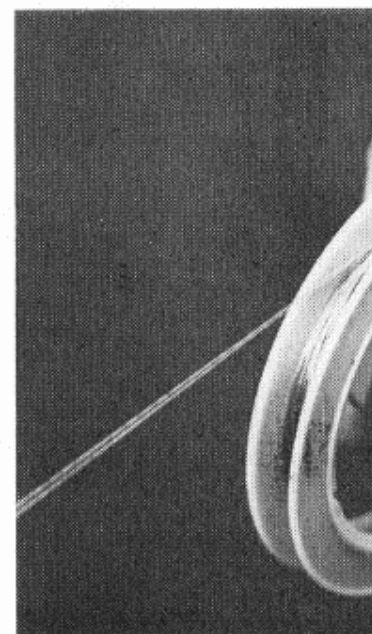
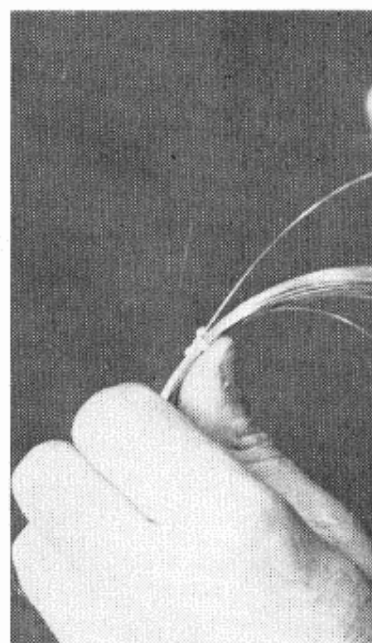

Top pic wire be cotton l slid aro of line When u pull dir above -

| | | SINGLE STRAND STEEL | | | STRANDED STEEL | |
|-------------|------------|---------------------|-------|-------|----------------|-------------|
| ENGINE SIZE | THREAD | 0.2mm | 0.3mm | 0.4mm | Lightweight | Heavyweight |
| 1/2 - 1/4 | 1/16 - 1/8 | / | / | / | / | / |
| 1/4 - 1/8 | 1/16 - 1/8 | / | / | / | / | / |
| 1/8 - 1/16 | 1/16 - 1/8 | / | / | / | / | / |

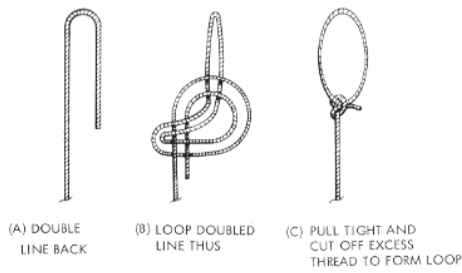

▲ Figure 2 — Thread lines

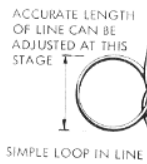

Figure 3 - Steel lines ▶

around the coil. Take your time, and do not lose that last piece of binding: if you do you will have a huge tangle – impossible to sort out. This is because the wire has a natural spring action: it is vital to keep the coil under strict control.

With stranded wire (which frequently is sold on a reel which automatically overcomes most of the previous problem) the 'springing' tendency is still present – but to a far less marked extent. In fact, the care of handling is one of the main virtues of this type of control line. However, remember that with any type of wire control line that it is important to unreel the line off a storage reel in line with the drum, and not off the side as this results in a coil spring effect once unrolled.

Make up the loops in each end in turn as shown in Figure 3 – making sure that the two lines are identical length when pulled taut. Make sure that you use a minimum of heat when soldering the ends, as too much can weaken the line. Some stranded lines now available are made from stainless steel, which gives several advantages.

Firstly, stainless steel will resist corrosion better and secondly, this type of line is usually made on the 'cored' principle. The wire generally has seven strands, one of these runs through the centre whilst the other six are twisted around it, this gives a comparatively smooth external finish to the line, compared to the more normal three strands which are all twisted, then tinned together to form the line. Stainless steel lines have much less inherent 'spring' in them and give excellent results, although they are considerably more expensive to buy. One disadvantage however is that stainless steel cannot be joined by normal soldering. Instead line ends are made by crimping a short copper tube over the wire (Figure 4). There are of course other methods of making up ends, any of which can be used provided that they are known to be safe. I would like to emphasise the value of colour coding each line (I use red for 'up', black for 'down'). This finishing touch ensures that you attach the lines to the model correctly each time, and the smooth finish of the end eliminates any possibility of the ends of the lines locking together. Having made up your set of lines all that remains is to pull-test them to ensure that they are safe.

Figure 4 — Stainless steel lines

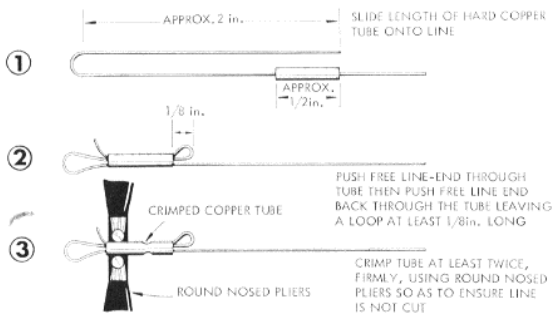

AEROMODELLER

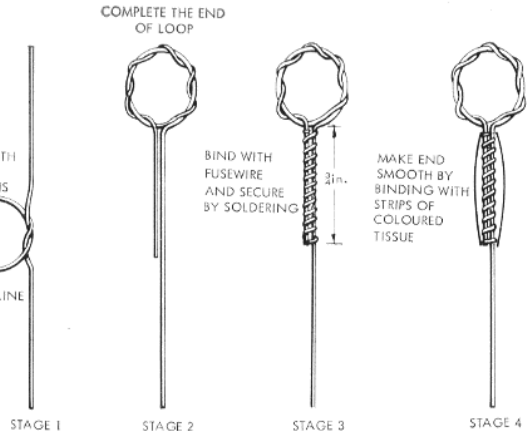

General Care and Storage of Lines

Once again thread lines present the least problems. They are in any case used generally for short line lengths and are not damaged by storage on small reels. In practice the most convenient method of storage is by winding directly on to one of the commercial moulded handles made with this provision. The only likely cause of failure is fraying which can be checked visually before use. Fuel is unlikely

Below: Stranded lines are now available on both reels or coils, whilst single strand wire is available in coils only. The plastic pram wheel shown makes an ideal storage reel when the tyre is removed. At bottom is a Sullivan control line handle which give the option of having close-coupled lines for reduced sensitivity (as used by racing enthusiasts) or wide spaced for maximum movement. With this handle, line length may be adjusted by slackening off the clamp and altering the length of the heavy duty cable. Simple but effective.

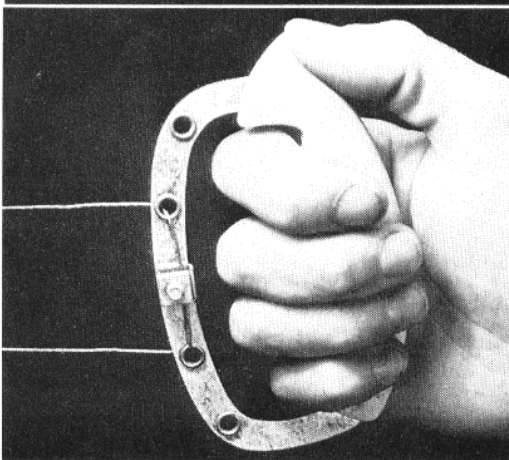
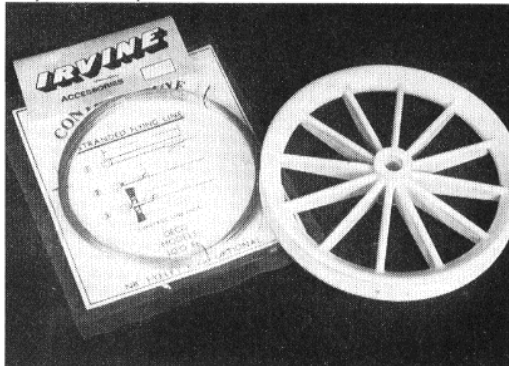

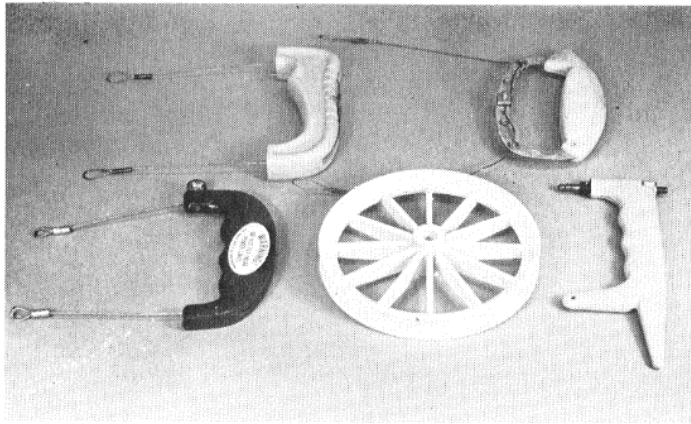

A selection of control line handles - which you choose depends on individual preferences. At the top are two handles by Sullivan - both featuring moulded plastic grips and line length adjustment via altering the heavy duty cable. Below left is the newest product to hit the market (although not yet available in the UK) - the George Aldrich Magnum handle, moulded in nylon and weighing just 3oz. Again line adjustment is via the heavy duty cable shown. Flanking the pram-wheel line storage reel on the right is the British old favourite - the Davies Charlton device with spike to dig into the grass, which helps you find the handle when the engine is started. Line length may be altered via threaded rod adjuster.

to cause any problems during the average life of a set of lines, except for showing up slipping knots.

Wire lines should be stored on a large diameter reel. For single strand lines the diameter should be of the order of 6in or more, and for multi stranded lines 6in or so is about right. Whichever type of line is used it is a golden rule that a careful inspection should be made before each flying session. Look for any kinks or cuts that could affect the safety of the lines. If you find *any* flaws, then discard the lines. Remember it is always easier to re-make or replace a damaged line, than it is to repair a model damaged after a line break. Try not to leave lines attached to the model on hard surfaces, as people treading on the lines over a stony surface can cause weak points.

All metal lines should be regularly cleaned. Almost any solvent can be used provided it fully evaporates leaving no greasy residue. Personally, I use cellulose thinners on a soft rag.

Pull Testing

This is an aspect of line care that often strikes terror into C/L flyers, quite unnecessarily. If your model or lines cannot take a pull test of 10 times the weight of the model, repeatedly, then they are unsafe. If flying competition models, then check the rule book for correct line pull poundage - and be careful to pull both lines evenly to spread the load. Even if you do not fly in competitions take any opportunity to pull test your model and lines. This way you will become accustomed to pulling the approximate poundage as a rough test before each session.

Control Line Accessories

Many different control line handles are available, and the following considerations may be helpful when choosing yours. For any type of flying a method of easily adjusting the relative line lengths is most useful. Aerobic flight requires line centres of approximately 4in with the lines flexing from a position close to the wrist, but for racing models the line centres are generally much closer at about 2in in order to reduce sensitivity of centre. Naturally any handle you use must suit yourself, and must be comfortable to hold.



A good clip should be used at each end of the line. Some suitable commercial clips are available (for example Sullivan) but you may find it necessary to contact a specialist model shop to obtain supplies: as an alternative small diameter split rings may be used. Fishing line swivels are often used, but require careful use to ensure safety - they generally look stronger than they are and are not really recommended for larger models. If in doubt test a sample attached to sample of line used, should the swivel fail or open up before the line fails then it is not sufficiently strong. Personally I do not believe that it is necessary to have a swivel action at the end of the line, and prefer to remove the swivel part leaving only the clip end.

Special Variations on Control Lines

I have so far talked only about standard methods of control. However, several specialised variations are used, mainly in competition. Because of their specialisation, they are not recommended for the inexperienced flyer, and I shall therefore not describe them in the same detail.

'Monoline' is a method of control using only one line. This is generally thicker than the line that would normally be used, but the overall effect is still a significant reduction in drag.

The above system is used only for speed models. Elevator movement is achieved by twisting the line in torsion and it takes approximately twenty turns of the line in each direction to achieve full movement at the model end. Two types of handle are used, the oldest design is the American 'Stanzel' type which sadly is no longer manufactured. This consists of two pieces of wire, spirally wound like the handle of a wire brush, and rotation is achieved by moving a bobbin backwards and forwards along its length. The second type comes under the general name of 'Uniline'. In this type a grip is moved in the normal way, however, attached to this is a segment of a large gearwheel. This gear translates through more gears the handle motion into rotary movement of the line. At the model end the rotation of the line is changed to elevator movement by one of two methods. One uses a torsion beam in a tube (or torque converter), giving a spring loaded central position. In the other the worm wheel and follower pin produces the movement which is not at all self-neutralising. In any case the Monoline system is never very direct, and its use is limited to speed flying where its inadequacies can be lived with.

Another variation that has been used in speed and racing is grouped lines. Here one line has a series of small airfoil mouldings or tubes attached at approximately 12in centres. The other line is then passed through the



Above is an example of a 'Uniline' handle, which is used to control speed models flown on a single wire, whilst retaining conventional control line operation. As the handle is raised to give 'up' control, the centre portion remains horizontal and the line is twisted to provide control and vice versa. The Stanzel type handle (above right) described in the text performs the same function, but elevator control is effected by sliding the bobbin forwards or backwards along the twisted wire centre of the handle. At right, is the monoline model's torque - converter control system. The control line is attached to the button (bottom right) while the T-shaped arm is anchored in the model. As the control line is twisted, the horn moves backwards or forwards to provide up and down control.

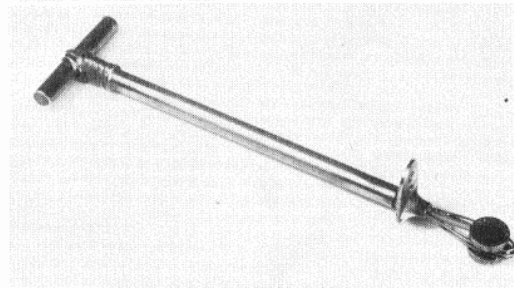
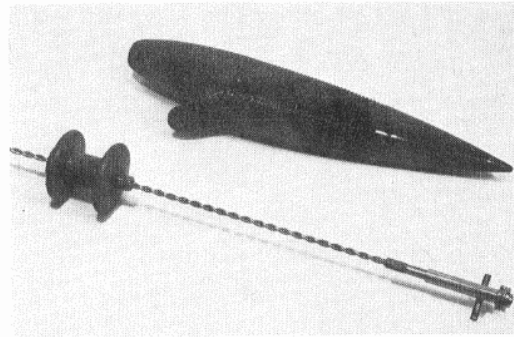

tube or moulding. In flight the two lines are held in parallel to the line of flight thus presenting far less area to the passing air. However, their use is now banned for racing and some speed classes.

Often the control line modeller wants to operate other features beside the basic elevator control, such as throttle control, flaps, retracting undercarriage, bomb bay doors and many more. These features can be handled by one or both of two basic systems. One is a mechanical system using three lines operated by a special handle and coupled to a bell-crank which ensures that whatever control is selected the flying strain is always taken equally on all three lines. Commercially this system is known as the

Roberts 3 line system, or generally as 'balanced 3 line'. The Mick Reeves system detailed on pages 24/25 is a good example of what is possible.

As an alternative, or in addition, electrical means of control can be employed. All that is necessary in this case is to ensure that electrical insulation is achieved. Usually this is achieved by varnishing the lines or find a suitable commercially coated line.

TRIMMING PROCEDURES

continued from page 15

slower than a model with less weight while still maintaining good line tension throughout. Once again though, do not overdo it. Remember that every ounce of tip weight is an ounce on the total weight of the model and two of the most important features of a good aerobatic model are low wing loading and a high power/weight ratio.

You should now have a model that is as well trimmed as any competition model flying today, but before declaring it fully sorted out it is worth spending a little more time on the front end. I have already talked a little about propeller selection, but now your model is properly trimmed you may decide that a different size would be more suitable. For example, if you would prefer to have a little more time to get through each manoeuvre then fitting a slightly finer pitched prop should do the trick. On the other hand you may feel it needs that extra turn of speed to help the line tension in which case an extra inch of pitch will usually cure the problem. Take care not to over-prop the engine as this will obviously drop the revs and hence reduce the power available.

While thinking about the motor, make sure that you are getting a consistent and similar run in both normal and inverted flight. If your tank has been made removable it should be a simple matter to adjust its height relative to the spray bar. Remember, the motor will run leaner

(and hence faster) the more it has to suck for its fuel, so raising the tank will have the effect of slowing it down in normal flight, but will tend to speed it up when inverted.

Finally, you may decide to make a minor adjustment to your line length. Remember that slightly longer lines will give you just that extra bit of air space for the more complex manoeuvres. My line length tends to be determined by how well the model performs the reverse wing-over on a fairly breezy day. If it completes this manoeuvre without struggling too much it should complete the rest of the schedule in relative safety. Of course you can have problems in the opposite weather condition - a flat calm. Here with no wind to help, you are relying solely on the trim and speed of the model to maintain line tension. In general I have found that it is possible to use longer lines on a windy day than a calm one, contrary to popular belief.

So there we are. It all sounds a bit tedious and long winded, but it does not really take very long. Two or three flying sessions are usually enough to sort out the basic trimming with perhaps a little more time required to settle on the finer points such as propeller size and line length. You may not entirely agree with some of the things I have said and everyone tends to evolve their own methods anyway, but at least it should serve as a guide to those who, like myself some years ago, thought that trimming a stunt model started and finished at the addition of some tail weight! Just remember a well trimmed model in the hands of just an average pilot will always give a good account of itself.

PLASTIC 'PLANES

HOW TO FLY YOUR READY-MADE MODEL SUCCESSFULLY

MANY EXPERIENCED aeromodellers tend to be disdainful when the subject of plastic ready to fly control line aircraft is raised – but this is the wrong attitude. Toys for boys? Certainly – but they can also be a first introduction to 'real' aeromodelling, and that alone makes them most worthwhile. They are also fun for the youngster to operate and the sense of achievement of making your first successful 'solo' flight is one we all remember.

Regrettably, many of these aircraft have achieved a bad reputation over the years and many are the tales of woe that they do not work/fly etc. Some of these complaints may have been justified, but remember that these remarks are made by novices, often reflecting their own mistakes. We were pleasantly surprised to discover that the two models chosen for this feature flew so well – far better than anticipated, and a great improvement over previous experiences established perhaps ten years ago.

The instruction sheets supplied with each of the models proved most useful, but the purpose of this feature is to provide additional information to assist the beginner in achieving success – but do read the instruction leaflet,

Below is the Cox Cessna 150 which is supplied in component form - just needing the parts slotting together and the self-adhesive decals applying to complete. Fuselage halves are joined by rubber bands - a heavy crash allows parts to fly-off, saving damage. At bottom is the Keil Kraft Hurricane which is sold fully assembled. An all 'chrome' version is also available at extra cost. Both proved very sturdy - deliberate vertical dives into the ground failed to cause damage.

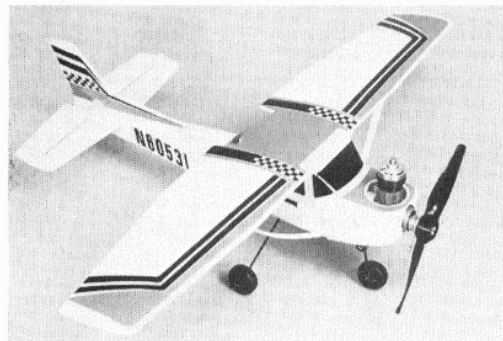

20

supplied with your aircraft, first. And read it carefully too!

Essential Accessories

The Keil Kraft *Hurricane* was supplied complete with glowclip and lead, this being fitted with a two pin plug to suit an Ever Ready AD4, 1.5 volt battery. This battery is ideal for our purposes, but is not essential, so if one is not available locally (your model shop should have one) then use an alternative 1.5 volt heavy duty battery, such as a bell battery. However, ensure that it *is* a heavy duty battery – the glow head you have to connect it to draws around 3 amps – and that the voltage does not exceed 1.5 volts. Torch batteries will not do!

To fly your *Hurricane*, you will also need special fuel, available from model shops, known as 'glow fuel'. There are many grades of fuel available, with varying prices according to the nitromethane content. You require fuel with 10-25 per cent nitromethane, suitable brands being Keil Kraft *Nitrex 15*, Model Technics type *G-500*, *G-600*, *G-500E* or *G-500L*, Cox nitrated glow fuel, or Irvine *Tiger Contest*.

The Cox *Cessna 150* was not supplied with a glow clip, and here one has two alternatives. You can either purchase the Keil Kraft glow clip as a separate accessory and then use the same battery and fuel as previously described, or purchase a Cox *Flight Pack* which contains fuel, battery glow clip/leads, fuel filter and two special spanners.

One point to bear in mind is that batteries do not last for ever – if your engine becomes hard to start, then the battery is always a prime suspect – see later notes. The life can be extended by taking care not to short out the glow clip by leaving the two terminals touching a metal object or even damp grass, and by not leaving the battery connected to the engine for longer than absolutely necessary. Even so, their replacement will be a fairly frequent expense. An alternative is to purchase a 2 volt lead/acid accumulator from your model shop, which is re-chargeable and should last for around three years if properly looked after. However, you also need a suitable 2 volt charger, so the total initial outlay would be £8-£10, rather than £1 for an AD4 battery. Also, if you do choose a 2 volt accumulator, then use 6ft-9ft of bell-wire to connect the glow clip to the battery in order to drop the voltage down to 1.5 volts. Excess voltage will destroy the glow head's element. More expense!

Other useful equipment to take to the flying field include a pair of scissors, small screwdriver, rubber bands (for Cox model) a clean cloth and perhaps a can of 'Pledge' furniture polish, as this will clean up the model nicely when you have finished flying. An assistant is also essential!

Flying

Ideal flying sites for these models are your school or recreation ground. Ask a friendly teacher for permission to fly your model after school, and he will probably be keen to assist. Do not choose the cricket pitch though – the fuel will ruin the grass! If you prefer a recreation ground, then remember that these little engines do make a bit of noise, so be sensible and remember that other people may not like to be awoken at 6am. . . .

To take off from the ground these aircraft need a smooth tarmac surface – short grass is not good enough. However, tarmac is also much harder than grass if (when)

CONTROL LINE

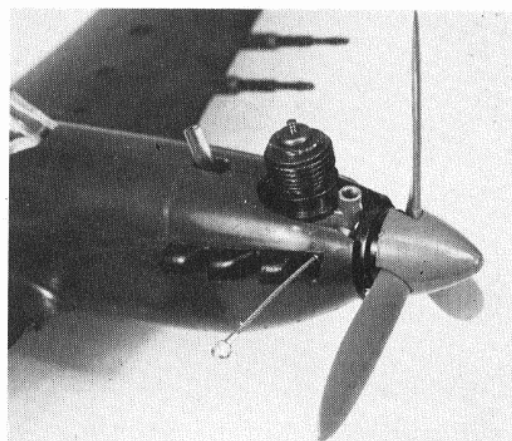

you crash A compromise is to position yourself so that the model takes-off on the tarmac while you stand on the grass. Then as soon as it is airborne you can walk further onto the grass, with the model well clear of the hard surface.

Make up the flying (control) lines so that when the model is held at waist height by your helper, the control handle is upright and the elevator is 'neutral'. Check this while pulling gently on the lines - if one is slack then re-adjust. Also check that when you raise your arm that the elevator moves 'up'. That is important!

Cox recommend lines to be 15ft long, while Keil Kraft suggest 23ft. We found 15ft to be fine for both models, and would not have liked to exceed 20ft for the *Hurricane*. The longer the lines the more tricky the model is to fly if there is a bit of breeze or if the engine is not running at exactly peak performance. Start off on the shorter lines and then increase them as your confidence grows.

Do not try to fly in windy conditions - although a slight breeze is quite acceptable. Make sure that the aeroplane is pointing downwind when you are ready to fly. This may seem against normal practice, but the reason is that this gives the model a chance to pick up speed after take-off before having to do 'battle' into wind.

Fill the tank with the correct fuel, have a piece of rag handy, and check that none of your equipment is anywhere near the flying area. Move everything except the basic essentials at least ten feet away. Check also that no-one is standing in the way - or is likely to - people often crowd around, but ask them to keep well clear. Connect the battery and start the engine. If the engine runs

backwards (i.e. the draught from the propeller blows forward) then do not worry, nothing is wrong. Just throw the rag into the propeller to stop the engine, and start again. These engines often do start in reverse. No harm will occur.

Incidentally, we originally had trouble starting the Keil Kraft *Hurricane* and this was traced back to the fact that the battery was not heating the glow head, even though it was a new battery. Cause was that the anodised finish on the glow head was insulating this item from the cylinder fins beneath. Solution was easy - just move the lower arm of the clip so that it rested against the underside of the red-anodised glowhead - as here the anodising was removed. An unusual snag - and one we have never experienced before. Worth checking before you discard that battery as useless. If you cannot get the engine to run after following the instructions, then consult the following trouble-shooting section.

When the engine is running, disconnect the battery, and slowly screw the needle in a little - you will hear the engine speed up. Unscrew the needle a little again to slow it down, and let it run until all the fuel is used up. This helps to 'run in' the engine, just like a motor car. Repeat this a couple of times ideally. Running the engine slowly with the needle valve unscrewed is called a 'rich setting'. The needle controls the amount of fuel going into the engine: air also enters the engine at the same time and the two mix to form a fuel/air vapour inside the engine. If more fuel is allowed to enter the engine, the vapour becomes 'rich' with fuel. If less fuel enters the engine, i.e. when the needle is screwed in, then this vapour is 'lean'.

Pictured at top left is the Cox powerplant - the gauze screen around the cylinder is presumably a U.S. anti-fire requirement as it is termed a 'spark arrester'. Top right is the Testor glow engine used in the *Hurricane* - the anodised glow head insulated this item from the cylinder fins when the battery was connected. Solution was to make sure that the glow clip was attached to the centre stem and the glow head itself, as the anodising was removed on the underside of this item. Note that the Cox runs backwards (clockwise) and thus uses a left-hand prop. Make sure that it is fitted the right way round. At right are the essential starting aids. The Cox fuel and battery plus glow clip and spanners are from the Cox Flight Pack - available at extra cost. The Ever Ready AD4 battery is shown with the KK glow clip (supplied with the *Hurricane*) and appropriate fuel. Both battery and glow clip combinations will suit either model.



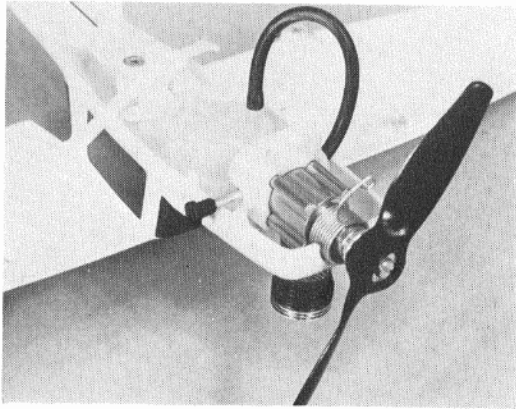

The Cox was supplied with a long length of fuel tubing (left) and this could have caused problems - so it was cut down to the minimum as a precaution against kinking and potential fuel feed troubles. The Cox also features an 'auto pilot' which simply disconnects the elevators from the control lines. Idea is to use this for initial flights but we found it more of a handicap than an advantage. Move the lever to hand control and all is well.

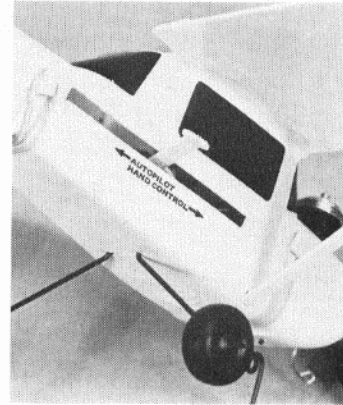

Now half-fill the tank (the *Cessna 150* has two vents, one to half-fill the tank, the other to completely fill it - but you will have to guess with the *Hurricane*) and restart the engine. Screw the needle in slowly - to 'lean out' the engine - and adjust for maximum speed. If you overdo this, the engine will stop - so open the needle half a turn and try again. When the peak speed is reached, open the needle valve (i.e. richen the fuel mixture) approximately $\frac{1}{4}$ turn. This is because the engine will speed up in flight, and require a little more fuel.

Check that all is clear, before take-off. If the model is to take-off from the ground, then get a helper to just release the model or *gently* push it forwards. Keep the control lines taut, and apply up elevator by raising your whole arm - do not just bend your wrist, as this leads to over-control.

Take-off can be tricky, but remember at all times to keep those lines taut - be prepared to 'lead' the model by pulling it around in a circle, or to step backwards smartly in case the lines go slack. It is important to keep that flying arm rigid - although maybe your wrist is quicker, you will almost certainly over-react and crash the model.

As soon as the model is airborne, walk backwards away from the tarmac and concentrate on flying straight and level - it is not as easy as it looks. Giddy? Watch the aeroplane, not the background.

If you prefer to try a handlaunch rather than let the model take off by itself, then make sure that your helper knows what he has to do. With the engine running properly as before, he should stand downwind of the pilot with the model held at shoulder height. When you are ready, he should trot forward a few feet and *gently* push the model on an even keel, straight ahead, or with the nose pointing away from the centre of the circle in order to keep those lines taut. He must not throw it violently, force the nose up (or down) nor let the model come towards you!

It is quite likely that he will not do this job quite correctly - or even if he does, the model may 'drop' a few feet before picking up and flying properly. Be prepared for quick remedial action.

When the engine cuts, land by leading the model with the handle as you pull on the lines and apply up elevator to pull it round for a smooth touch down.

Trouble shooting - Flying

Problem: model flies very slowly, hard to control or stay in air

Most common reason is that the engine has been adjusted incorrectly - tune carefully for maximum speed, then open the needle $\frac{1}{4}$ turn, or more if necessary. How-

ever, if the engine sounds healthy, but the model is still slow, check that the propeller is fitted the right way round - the manufacturers name (Keil Kraft) or the propeller size (Cox) is moulded onto the side of the propeller that faces forward.

Problem: lines continually go slack, with loss of control

Most likely cause is an inexperienced pilot, but check that lines are not too long, or that wind is not too strong.

Problem: model refuses to take-off from smooth ground

Control handle is upside down, or controls have been hooked up in reverse.

Problem: engine dies out in the air

Open needle valve another $\frac{1}{4}$ turn and try again

Trouble shooting - Engine

Problem: engine does not 'fire'

The engine operates on the 'glow plug' principle: that is, a fine coil of platinum wire in the glow head is heated by means of a battery. The propeller is then turned over rapidly (by means of the spring starter) and the fuel is ignited by the coil of platinum - known as the element. Once the fuel is ignited and the engine 'fires', then runs, the battery connected to the element may be removed as the heat from the combustion process combined with the chemical effect of the fuel on the platinum will cause it to 'glow' by itself.

The most common cause of a non-starting engine concerns the initial 'glow' supplied by the battery, so if your engine will not 'fire' carry out the following:

(a) Remove the glow head using a correctly fitting spanner. If the cylinder itself starts to unscrew then grip it *lightly* with a Mole wrench, using a piece of cloth or better still sheet lead in the jaws to protect the cylinder. Caution: Adjust the wrench very carefully to suit the diameter of the cylinder head, and do not risk over-tightening. *Just* grip the fins. Do not use pliers, and *never* pass a screw driver or any piece of metal through the exhaust ports to prevent the cylinder from turning.

(b) With the glow head removed, connect the battery and check the colour of the element. It should glow *bright orange* - if it is only dull red, then the battery is at fault and should be replaced. If there is no glow at all, then either the battery is 'dead', or the element has burnt out and the glow head must be replaced with the *correct* replacement part.

(c) If the battery is new but the element still does not glow bright orange, then check that the connections are good and clean, and that the leads from the battery to the glow clip are not more than approximately two feet long.

If you prefer to use a hand-launch, then brief your assistant to hold the model at shoulder height and to launch the model on an even keel with the nose pointing straight forward or slightly away from the centre of the circle to keep the control lines taut. He should trot forward a few steps and gently push the model so that it is near its normal flying speed on release. Gentle push is the term - not a violent throw.

This is because the glow plug element needs a 1.5 volt supply, and longer leads would cause the voltage to drop. Should a 2 volt accumulator be used instead, then make sure that the leads are 6ft-9ft long to drop the voltage to 1.5 volts.

(d) Replace the glow head - making sure that the sealing washer has been replaced first, and that there is no dirt anywhere near the engine. Tighten the glow head with the spanner, but only 'nip' it up tight, do not force it. The engine should then start.

Problem: engine fires but runs erratically

Most common cause is that the sealing washer beneath the glow head has been omitted after the head has been removed, or else the glow head itself is loose. Alternatively a piece of dirt may have been trapped underneath the glow head when it has been replaced, causing a leak at this joint.

A simple way to check a leak between the glow head and cylinder is to squirt a little fuel over the cylinder head, then watching the joint, operate the spring starter to revolve the propeller. Any leak will be shown up by bubbles.

Another source of trouble could be the fuel employed - make sure that the glow fuel is as previously recommended.

More obscure problems could be either a bent fuel valve (caused by a crash perhaps?) or the cylinder head has been replaced cross threaded and is thus out of line, causing the piston to stick in the bore. It is also possible that the backplate in the Hurricane's engine has become loose - retighten it.

Problem: engine starts and runs well, but dies out after a short period

This does happen with some engines, but there is nothing in fact wrong! All engines benefit from running in when new, and your miniature unit is no exception. If your motor does tend to stop after a brief period, merely open up the fuel valve unit so that the motor runs slowly and unevenly. Run several tank-fills of fuel through the engine in this way, allowing it to cool down thoroughly between each re-fuelling. After this operation has been repeated 4-5 times, screw the valve in until the engine reaches its fastest speed. Do this slowly to enable the

The Cessna features two re-fuelling tubes - one to give a full tank, the other half full. Use the latter for first flights. Note how model is on tarmac with grass beyond to permit take-offs and a soft landing place!



AEROMODELLER



engine to react to the adjustment. When fully run-in the motor will hold its top speed constantly - although when flying it is best to open the valve a further quarter-turn from the peak-speed setting.

Problem: engine runs but soon slows down

Cause is the fuel valve rotating under vibration. Normally the spring prevents this but it may have become compressed. Remove fuel needle and stretch spring slightly then replace. On the Hurricane, the spring is tapered - the wide end should fit against the tank unit, the narrow end on the fuel valve. Check that it is this way round.

Maintenance

Virtually no maintenance is needed on these engines - just when you have finished running the motor, make sure the fuel tank is empty, close the fuel valve and then preferably inject a few drops of light machine oil (such as '3 in 1') in through the exhaust ports. Turn the propeller over several times to distribute the oil over the engine's internals.

Make sure that no dirt ever enters the engine as this will certainly cause damage (take special care after a crash) and never overtighten the glow head or cylinder. Above all, avoid holding it in a vice or with pliers or any other tool likely to cause damage. Avoid passing any metal object through the exhaust ports.

Finally, cover the engine with a plastic bag to prevent dust from entering it.

Starting the engines is quite easy thanks to the spring starters - the K.K. Hurricane features a particularly neat unit - just wind the prop backwards and release. Cox has to have the prop engaged on a spring before it is wound backwards.



THIRD LINE CONTROL

BY MICK REEVES

THE BELLCRANK system illustrated here was developed by the author shortly after his original three-line systems were published in

the November 1968 *AeroModeller*. These original systems worked remarkably well – enabling him to win virtually every Carrier Deck Landing

Pictures below reveal the operation of the bellcrank system drawn opposite, installed in Vic Willson's Bearcat. Note that the system is installed suspended from a ply plate and that the pictures show the underside of the fuselage – hence the 'mirror image'. Engine is installed to the right of the pictures. Note in the top two shots how the throttle bellcrank has been moved, without affecting the elevator control – the link arm is still vertical. Bottom picture shows opposite (low) throttle plus elevator movement. System is very simple – but make sure all pivots are free.

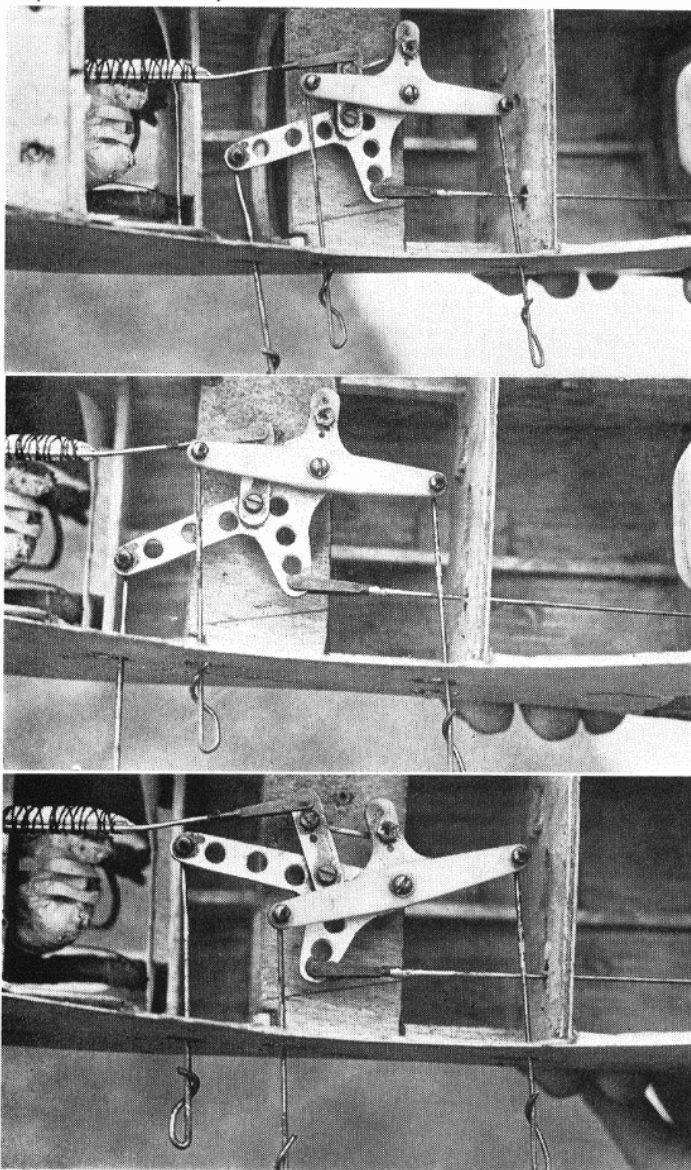

contest then held, and they are still very popular with scale modellers. However, the new system has several advantages – not the least being that it is considerably easier to make – and provides the facility for operating electrically operated functions (such as retracting undercarriage units) on throttle over-ride. Naturally, this latter aspect may be omitted if your ambitions do not extend that far!

Anyone contemplating building a scale control-liner would be well advised to fit a throttle control unit – it really transforms this type of model. Apart from the greater realism which can be achieved as the aircraft awaits take-off unaided with the engine ticking over, only to roll forward, gather momentum and then lift off on full power – it provides the pilot with a far more interesting craft. Now he can perform touch-and-goes at will, taxi around the circle, make low-level, slow speed passes, etc., as he wishes. Further, should your interest turn to carrier deck landing contests, then such a device is essential, while those who perform demonstration flying at fetes will find that their repertoire is greatly extended. Not convinced? Fit a throttle to your next stunt or sport model, and see the difference!

The unit is very robust, and may be assembled by slightly modifying commercial nylon bellcranks. Naturally, if you prefer, the bellcranks may be manufactured from dural – a file, hacksaw and drill are the only tools necessary.

This control unit is in fact a 'balanced' system – the flying loads are spread equally over all three control lines, regardless of the position of the bellcranks – so the unit may be operated with any 'normal' three-line handle, including the commercially available Roberts handle. However, practice has shown that a 'balanced' handle is not necessary – the designer preferring to spring load the engine's throttle arm to the 'low speed' position, and then to pull this to the fully open position via the third line; the handle used is also illustrated. Using this handle, with the middle finger placed in the wire ring, enables full speed manoeuvres to be flown when the handle is grasped tightly. Relax pressure on the middle finger, and the throttle closes – thanks to that spring.

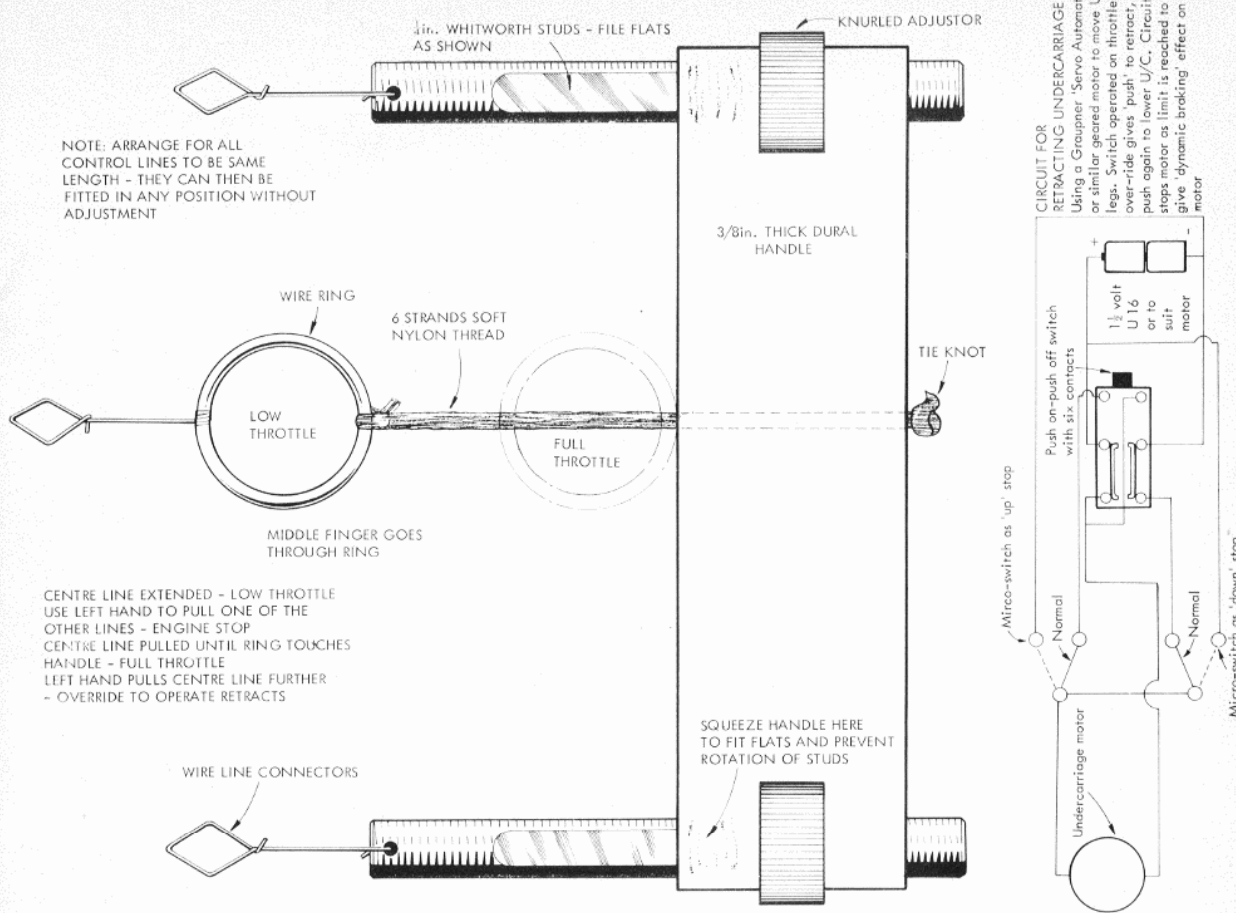

CENTRE LINE EXTENDED - LOW THROTTLE
 USE LEFT HAND TO PULL ONE OF THE OTHER LINES - ENGINE STOP
 CENTRE LINE PULLED UNTIL RING TOUCHES HANDLE - FULL THROTTLE
 LEFT HAND PULLS CENTRE LINE FURTHER - OVERRIDE TO OPERATE RETRACTS

DETAIL SHOWING HOW MOVEMENT OF THROTTLE DOES NOT MOVE ELEVATOR

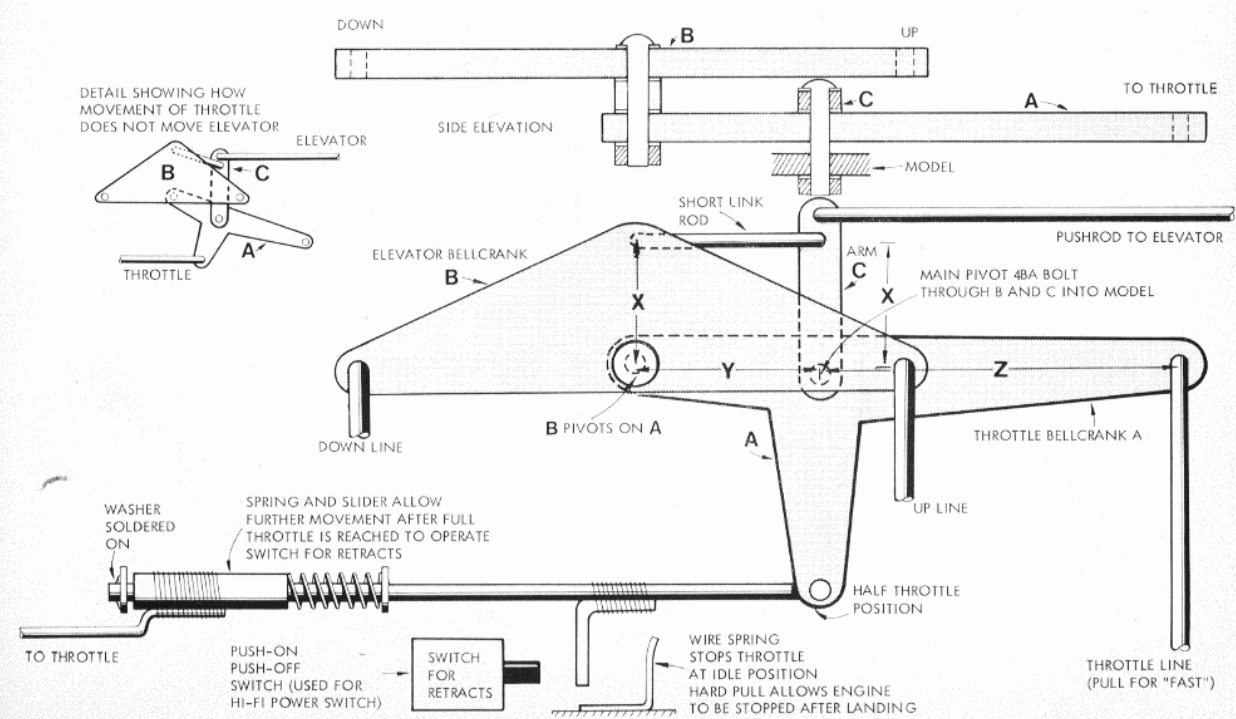

EXPERTS INTERVIEWED



GEORGE ALDRICH

**MOST RESPECTED
AMERICAN DESIGNER
AND ENGINE TUNER**

George, you will probably always be best known for your Nobler aerobatic design: a model which was subsequently kitted by Topflite and marketed all over the world. The fact that a version has probably been flown at every major event since it was first designed (and that Bob Gieseke flew a modified version to become World Championship in 1974) speaks volumes for its performance, and it is hard to believe that it is now around 20 years old! When did you build your first prototype, and in what year was it first kitted? Did the kit version vary much from your own original?

The *Nobler* was designed in November of 1950 – at least the initial layout. This layout comes from some test models I had built the previous summer. Using the old Veco *Chief* wing (I flew this model to 4th place in the 1950 Nats), I built quickie box fuselages around it to test various moment arm configurations. One model with only 2in between trailing edge of flap and leading edge of stabilizer could be made to hover motionless at the bottom of an outside loop by applying full down control! Apparently, the coupled flaps blanked out all control, giving a big zero, stalled condition. Another model with 12in between flap T.E. and stabilizer L.E. accelerated through loops

and would tighten up in manoeuvres beautifully without stalling. The *Nobler* as it emerged was a compromise of these tests.

TopFlite first made arrangements to kit the *Nobler* in 1956, with the first kits being shipped in the spring of 1957. The kit varies somewhat from my original, in that the basic wing was shortened to meet balsa length sizes and the stabilizer and elevators were reduced in span to give a bit more of a scale appearance. Of course the sheet over formers fuselage was substituted for the hollowed balsa blocks to keep the cost down, and it's pretty hard to put 4–5 pound/cu ft balsa blocks in a kit.

Taking a long look at its fantastic success record – why do you think it proved so good? What sort of opposition did it face in the early days?

It's hard to say why it has been so successful. The real difference was the moment arm change and the flap to elevator movement ratio. By lengthening the tail moment arm I found the flaps could be given more movement and thus produce more lift. The original actually had more flap movement (50 degrees) than the elevator (45 degrees), due to the linkage system used at that time. I later set this up on a 1:1 ratio with 45 degrees movement. The great Bob Palmer was most instrumental with encouragement, both to experiment and to not only practice but really be prepared. I certainly had only a free-flyer's knowledge of aerodynamics. With this as a base I just combined hard earned experimental findings with what I thought 'looked right'. Although the first *Nobler* was 'right on' from the beginning, this wasn't an accident really, due to all the preceding models.

Stunt in those days (1947–1951) was flown by most as a spectacular event. I remember Russ Snyder, who was placed 3rd behind Don Still at the 1949 Nationals, doing five outside loops once and touching the fin on the concrete five times! About a quarter inch was ground away from the fin tip. My older brother used to fume over this type of flying. Remember, these were big 60 to 65 cu in powered models! Orwick

Photographed in May of this year, George surveys the remains of the original *Nobler* demolished in 1964 when a down-line broke. Every piece was collected in a pillow case and one day, he claims, will be glued back together again!

64 s, Atwood .60 s, Anderson Spit .65's, hauling 500 to 800 sq ins at speeds from 80 to 100 mph. At any rate his coaching was, 'Slow it down and make the manoeuvres big and smooth like a real aeroplane'. Obviously, there were conflicting factions on what the pattern should look like. At the 1951 Plymouth Internationals I flew before judges that liked my style for the first time. I mark this as the beginning of precision aerobatics as opposed to 'Stunt'. Not that the spectacular did not require precision. No one who ever saw Don Still pull out of a wing over with the wheels on the deck can disclaim precision. But, at this time, I flew loops and eights at a 60 degrees maximum allowable, and Don Still, my arch rival, flew them at 30 degrees. When I was asked to write up the precision aerobatic rules in 1957 (no one else would take the job), I tried to draw a compromise between these two factions and come up with a pattern that not only would present precision but a unified, flowing, exhibition to challenge everyone. That this pattern survives today with few changes, other than the 'K' factor scoring (which I strongly disagree with) says this was achieved to some degree.

Would you say that the model was very advanced for its time – or has stunt model design stagnated for the 25 years?

This is most difficult to answer. I suppose the reason it has survived is that it represents the best all around compromise for its purpose. The old slob doesn't pop corners as some will, but they don't deliver the general smoothness, etc.

Today's trends are now towards larger models powered by engines of around 0.46–0.49 cu in capacity. Speaking as a judge, do you welcome this move? Are the models easier to judge accurately?

As a judge, model size or appearance makes absolutely no difference to me. I try to view each pattern by staring at the centre of the individual manoeuvre, rather than following the model exactly around its course. In this manner if the model doesn't track to the proper position that is required, it is easier to note. Attention must be paid to certain intersections, corners, etc., but the idea is to maintain an image in your mind's eye, and if the model does not track to this image, points are deducted. As to the big models being easier to judge or more impression – I don't think so. Gieseke seemed a certain winner in 1972, only to blow it by running out of fuel. He had been high the previous two days.

Still speaking as a judge, is there one particular aspect of the stunt schedule that catches out even the most expert fliers?

The hourglass is an impossible manoeuvre – seldom does anyone perform a really good one. However, the most desecrated manoeuvres are round loops! Rarely do I ever see three loops, inside or outside, that are really round, and tracked one on top of the other. Most are ovals. The other really

bad point is round figure eight intersections. Most fly a flat before turning. The model should break smoothly and start to turn just at the tangency point.

American pilots have dominated World Championships meetings for many years. What gives your men the edge over the Europeans?

The only thing I can think of is dedication and practice. Practice won't do it all, but with just a little critique it will cover a mass of inability.

Do you find that American judges tend to place different emphasis on scoring manoeuvres to their European counterparts?

The only experience I can draw on is 1972 in Helsinki. It seemed to me that the European judges seemed to categorize individuals – possibly because they judge the same flyers so much. An outstanding point at Helsinki was Cappi's flying. He steadily improved all week and his first flight in the finals was my choice as the best I saw that year. My score went out high (the highest points I gave all week), but fortunately one other judge agreed with me and it helped his placing. Unfortunately the others scored him, within a few points, the same all week. I certainly do not wish this to sound as criticism of my peers, but only a possibility toward better impartial judging.

Have you any views on how to improve judging methods so that the 'I wuz robbed' attitude of some competitors can be eliminated?

Firstly, I think all judges should be active stunt flyers. Not necessarily active competition flyers – but active! Impartial judging requires tremendous concentration. You must constantly try to keep all flights in your mind as you judge in order to always leave room for 'that better manoeuvre'.

Secondly, get rid of the 'K' factor! The first day at Helsinki my scores went out high or low about 50 per cent of the time. From that time on I made sure they went out only rarely (1 per cent–3 per cent). Under a 40 point maximum, one point minimum system, I don't think I, even as author of the pattern, could have anywhere near this kind of control. The 'K' factor places improper emphasis. In view of all the poor loops, is it proper for them (3) to have a lower K factor

than (1) hourglass?

In retrospect this may be the key to your question regarding American superiority. We fly the pattern under our 40 point maximum system for all manoeuvres. So, in practice, we don't slack any manoeuvre.

It must be several years now since you were heavily committed to stunt flying: in fact more recently you have made a real name for yourself in reworking engines. You must have been almost unique in earning your living modifying engines full time – is there really that much demand for 'hot' engines. Would it not have been easier, or more rewarding, to build your own engine complete?

My last active year of competition flying was 1964. Having no one to fly or share ideas with, and several active speed flyers in my area, I suppose, drew me into flying speed again after a 15 year lay off.

I backed into the custom engine business really. While flying speed I saw how many needed help and the free-flyers started ordering, and the pylon flyers, and the control line scale racing and so on... it just mushroomed. For several years I was about the only one to take on all comers and rework any engine. Now there are quite a few trying the game on a part-time basis. It is interesting and challenging in many ways, but very few can imagine the toll it can take on your personal life. At my peak I worked seven days a week, 18–20 hours a day, just trying to keep up. Frankly, the reward is nowhere near the toll it takes.

As to why I never built my own engine. The answer is simple. Money!!! I have some pertinent ideas about marketing my own engine – but I will save them for now. Now that I am accepting no more custom work, perhaps I'll eventually get an article or small book done on the things I learned over the years.

What, basically, were the modifications that you made to engines? What sort of power increase can you achieve from an already 'hot' motor like the Rossi 15?

All things being equal, 90 per cent of a really 'hot' engine is in the piston and cylinder fit and cylinder head. I guess you could say my forté is fitting cylinder assemblies and cylinder heads. The Rossi

for scale racing requires a different set-up than for free-flight, speed, etc. Such a Rossi must give hot restarts with regular style glow plugs, have a broad needle, excellent hot compression, a head design that's easy on plugs, and on and on. As to actual performance gain this could vary from 500 to 1,000 rpm on some to 2,500 on others. The choice of engine and event has much to do with it.

Were your engine hop-up customers in the main top line modellers, or inexperienced modellers who hoped to hit success with a 'special' motor? If the latter, were they capable of extracting the most from a GMA tuned engine?

Over the years my customers varied greatly, but on the whole I think they probably ran 75 per cent experienced modeller to 25 per cent inexperienced. Unfortunately, less than 30 per cent to 40 per cent ever realized the true potential of the engines.

How much importance do you attach to running-in (break in) of engines? Do you recommend different procedures for steel liners and those with an ABC set-up? How about if the owner intends to run high nitromethane content fuel – say around 50 per cent?

This subject could cover a full chapter of a book. ABC engines require little break-in. The primary thing in breaking in any engine is to do it in short bursts, not over 2 to 3 minutes long. Allowing the engine to cool completely between runs. I test run my custom Rossi 15's on 50 per cent nitro fuel on a prop that peaks out at 26,000 open exhaust, and 28,200 on the megaphone (my pet reference engine). Obviously, you do not break-in a Super Tigre 46 in this manner. Short two-minute, fast four-cycle, runs on a 5 per cent nitro mix, with adequate lube, on a 9×6in prop cut from an 11×6in is more in order. If we are talking stock ABC engine break-in and 50 per cent nitro, just run it a few times a tad on the rich side to seat the rod bushings, etc., and go fly. For

At right is a very young George Aldrich with his first stunt model in 1944/5. Used a Bantam 19 spark ignition motor. Below are two more designs he flew at the 1949 US Nationals – where he was placed third. The taper wing design used a Fox 59, the Barndoor a McCoy 60. Incredibly the prototype Nobler was designed in the following year. George went full-time into the model engine re-work business in May 1969, although this year he is concentrating on building up his fuel, glow plug and accessory lines, finding that re-working engines is too time consuming.

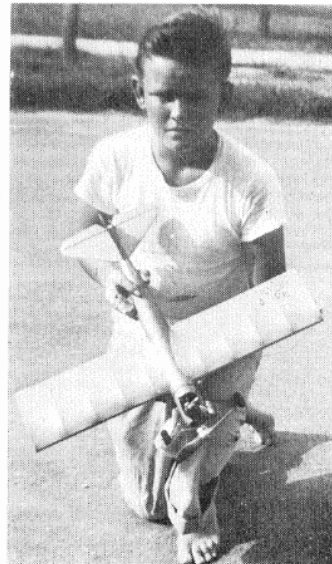
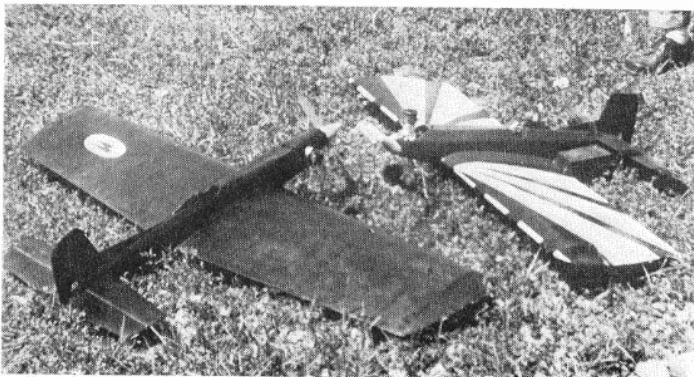

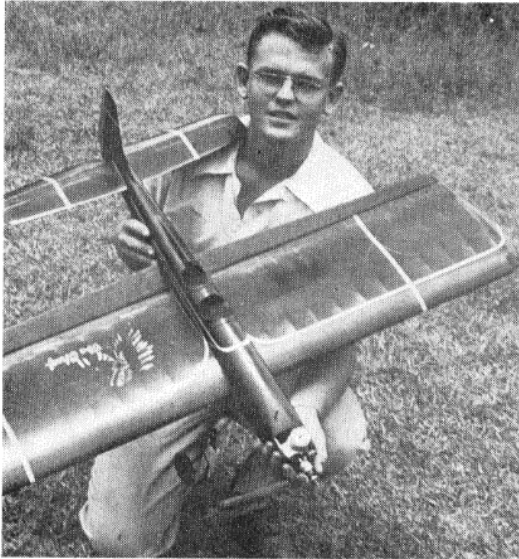

In 1950 George placed fourth in stunt at the U.S. Nationals with this Veco Chief - contrast this model with those he flew the previous year.

stock iron or ringed piston engines, start with low nitro and short fast four-cycle runs, gradually increasing the nitro as the engine comes in.

Have you any advice on choosing the most suitable glow plugs for an engine - and how to prevent them from blowing on every run?

Blowing glow plugs is primarily a function of: (1) compression ratio or head clearance; (2) cylinder head chamber shapes; (3) type of plug, i.e., hot, medium, or cool heat range. Some head chambers can easily be a compromise between performance and plug life. The double chambered squish head that comes in the Super Tigre X40 is a good example of this. I originally worked out this chamber shape in the old S.T. G40 in the late 1960's. The idea was to move the plug element out of the fire a bit, while maintaining good squish area.

The biggest error committed in most racing events is made on the starting line. Most flyers start their engine, bring it to peak rpm, and then back off 500 or more rpm to allow for the engine to 'unload' in the air. This is the way to set an engine for any race but not the place or time! When the engine is peaked on the line, 90 per cent of the time the plug is blown at that point and the chances of the engine running the full amount of laps are slim. In the old days, before the pipes, it was not such a problem to keep a plug for the full race. NO MORE!!! If the flyer will do his needle valve setting in the pits he has a far greater chance of finishing the race. The needle valve should be pre-set 500rpm or more rich, after peaking, *in the pits*. Then when called to fly, a new plug is installed, the engine is started and the model is launched *without touching the needle valve*, or is brought to a known position. Using this method the model leaves the ground with a 'cool' engine and the glow plug intact.

Why a cool and standard heat range plug? Basically, it works on this axiom - cold fuel-hot plug; hot fuel-cold plug. Unfortunately it is not always this simple. Under extremely

hot and humid conditions the smart flyer must be willing to make a compromise. After all what good does it do to have the fastest model, engine, etc., yet 'flame out' on the next to last lap. The score is still a big fat 'O'.

A cool plug will not tach, as fast as a hot or warmer plug. Under hot and humid conditions if a flyer will sacrifice 200 or even 400rpm by running a cool or standard heat range plug, and if he pre-sets or position sets, the needle valve, he stands a much better chance of not only finishing the race but winning it.

Compression ratio and head clearance were never more important nor critical than with racing events. Many times a switch from 50 per cent to 65 per cent nitro in an engine will accomplish no more than burning the plug out sooner. When there is no rpm gain, usually an increase can only be realized by raising the head with one or two .004in head shims. Another approach would be to leave the head setting alone and run less nitromethane. When the nitro content is increased the compression ratio is effectively increased also. No matter how well one can fly, a winner must finish the race.

Control line Rat Race and Scale Racing are other examples of a compromise event. The head clearance must be adjusted so as not to blow the plug or less nitromethane must be used in the fuel.

Do you have any preferences for mounting engines in models?

Obviously a rigid mount with true alignment is very desirable. Speed models show probably the finest way with the speed pan, dissipating heat as well as a rigid true mounting surface.

Turning now to your great interests in speed models, how fast do you foresee FAI class models (under the current rules) going in the next few years?

Speed modellers are probably the most persevering of all types. No event takes more work and money per minute of flying time. Providing the FAI doesn't preclude the advancement I can easily see 170mph (275 kph) being approached or surpassed.

Where do you think the greatest area for speed improvement lies in FAI flying?

It's anybody's game. With groupers out (Franco Marcenaro, now in the USA, outlined the grouper idea to me in my shop back in 1968), it will probably be with engine and model design. Chuck Schutte has done a lot with the sidewinder configuration. I know Carl Dodge was testing an FAI design with an eight foot inboard wing!

Do you anticipate that the FAI will introduce new rules to slow the models down in the interests of safety?

That's a good question!

If the models have to be slowed, how would you recommend that this be achieved?

Larger wire.

In your opinion, can efficient silencers be made: ones that will not destroy performance of high output competitive engines, and yet can produce an acceptable noise level? Would the compulsory use of such silencers kill interest of competition fliers in the USA.

I definitely think effective tuned silencers will come. O.P.S. and Rossi among others have very nice ones working. Our industry is in its infancy compared to the motorcycle manufacturers. I don't think a *workable* unit would hurt modelling in any country.

Finally, now that you are concentrating on your fuel and accessory business rather than engine work, perhaps you could let us know just what you can supply - and whether you have an importer in the UK. If not, how can we obtain your goodies?

We now offer six different styles of glow plugs under the Magnum label. At this time we are the only company offering two different styles of idle bar plugs. There is a Wide Bar R/C plug for the smaller engines up to a .35-.40. The Narrow Bar R/C plug is for Schnuerles and for the higher compression .40's on up. Both give an excellent idle in all engines but the Narrow Bar gives a bit more rpm and stands up better in larger engines. Since there are so few engines made that require a short reach idle bar plug our R/C plugs are only made in long reach.

The Magnum Standard and Cool plugs are made in both long and short reach. These plugs are designed to vaporize under over-lean conditions so that globs of element will not ruin a piston, cylinder, or both.

We finally started shipping our Magnum Control Line handle in January of this year. It is a close copy of the handle I took with me to Finland, and everyone who tried it wanted it. Perhaps it was a big gamble to take in our R/C oriented society as the first handle represented a \$7,000 investment. I always felt that a light handle helped me sense and feel the model better. The Magnum handle weighs only 1½ ounces in the package!

Perhaps the most significant thing I've done since the *Nobler* is the development of Magnum Power Fuel. This is the first new thing to happen in fuel since we switched from gasoline (petrol) to alcohol as a base. A significant power increase is realized for a given percentage of nitromethane. That is 5 per cent Power Fuel gives the power of conventional 10 per cent, etc. A great deal of testing of the fuel was done in helicopters, due to their overheating problems. More than one helicopter flyer has found our 15 per cent nitro fuel the equal of other 25 per cent nitro blends. In addition to the added power, this fuel offers these other advantages: runs longer per ounce of fuel, in that its viscosity is lower and the needle valve

must be turned in further for a given type of setting; much less residue on the model – clean up can be accomplished with just one facial tissue; resistance to seizure under over-lean conditions; and comparable operating temperature at the elevated rpm. As an example, during my tests there was a 400rpm with our 10 per cent gain Power Fuel over a competitive 12 per cent fuel, with almost identical operating temperature. When the engine was richened to give the same rpm our fuel ran 40 degrees–50 degrees Fahrenheit cooler.

We make the Magnum Power Fuel in 5 per cent, 10 per cent, 15 per cent, 25 per cent and 50 per cent nitromethane content blends. Recent tests with the 50 per cent fuel in a Super Tigre X40 showed a clean 700rpm increase, and 1,000rpm in my pet Rossi 15.

As of May 15, 1977, I have entered into an agreement to manufacture the fuel exclusively for Carl Goldberg Models Inc. A special concentrate is available in the 5 per cent, 10 per cent, 15 per cent and 25 per cent blends for export only. The 5 per cent, 10 per cent and 15 per cent are mixed at a ratio of two parts methanol to one part concentrate. The 25 per cent is mixed at a 1.5:1 ratio. Thus a 52 gallon drum of 25 per cent will give 130 gallons of fuel and a 52 gallon drum of 5 per cent, 10 per cent, or 15 per cent will give 156 gallons of fuel. The obvious advantage is the savings in freight to importers. I would think anyone who presently imports Carl Goldberg products could obtain our products if they so desired. Both Ripmax and Irvine Engines presently import the Goldberg line to the UK.

Anyone who would like our products but can't obtain them can order direct from Aldrich Products Inc., Mission, Texas 78572.

DEREK HEATON and MALCOLM ROSS

BRITAIN'S BEST RACING TEAM

As a team, you have dominated racing events – especially the FAI class – for many years now, so much so that at any Team Trials all fellow competitors know that you will be a member, and that they are really fighting it out to fill the two 'vacant' places! When did you first take up aeromodelling, and when did you first fly together in racing events?

AEROMODELLER



Derek Heaton the pilot, and Malcolm Ross the mechanic, are undoubtedly Britain's best FAI racing team – and have been for many years now. Their team-work is impeccable and they certainly have all the ingredients of World Champions – they just need a bit of luck to achieve the ultimate success they deserve.

We started modelling independently of each other (Malcom's career started with the Novocastrian club when about 10, whilst Derek dabbled from about 13 onwards). We started flying together with the formation of a small club and our first competition was the 1963 Northern Gala in FAI team race; there were well over 50 entries per event in those days and our first race lasted 63 laps.

When you first started flying in competitions, did you think that the current experts were unbeatable? Which teams were dominating the scene then?

In those days we never worried about being as good as the experts, we only went to competitions to enjoy a day's flying and we considered it a successful day if we improved on our previous best time. Names that spring to mind are: Laurie/Wallace, Nixon/Ellis, Long/Davy, King/Balch in FAI; Smith/Brown $\frac{3}{4}$ A; Yates/Hampson, Taylor/Yeldham and John Horton in 'B' and of course Place/Howarth and Turner/Hughes in FAI and $\frac{3}{4}$ A.

Did it take long for you to become competitive? Was the engine a standard out-of-the-box item, or did it need modifying to be race-worthy?

It took us just over 2 years to become sufficiently competitive to consider entering the British Team Trials for the 1966 World Champs; although we did not make the team that year it had been a close decision between ourselves and Nixon/Ellis for the 3rd place. We used standard ETA 15's until about '67 when after a string of 4th places (no semis in those days) we obtained a modified ETA from Don Haworth; this engine gave us the extra edge to start making 'final' appearances.

Our $\frac{3}{4}$ A racing was more successful as we reached the semis in our first Nationals, using a standard second hand Oliver Cub. In the first years of our racing, $\frac{3}{4}$ A was an extremely close fought event using standard engines – one National in particular had all semi finalists within about 5 seconds of each other!

Apart from the engine, were all the other components readily available? Were there, like today, enthusiasts willing to make special pieces of hardware?

When we started there were no special components required, squash bottles and wooden props were the order of the day. The main problem in those days was in keeping the finished model under the weight limit of 700 grams! Our early models used a mixture of steel blocks and Paul Pomadi pans and we only graduated to fuel shut-offs about 1970/71.

You have both watched the FAI class become more and more competitive. As standards have risen, more rules have been introduced, and now such items as circular bellcranks, metal crutches, fuel shut-offs, retracting (or at least spring-loaded) undercarriages are almost compulsory if one wishes to become really competitive. Is this necessarily bad in your opinion, or does it make the event more of a real challenge?

Many of these items are not new, circular bellcranks have always been common place on the continent, retracting u/c's have been used since the early 60's, i.e., Rosenlund and his Miss FAI winning the Criterium, and also the Sundell's.

Really none of these are essential (although a fuel shut-off is highly desirable, and may become mandatory in FAI). To be competitive both nationally and internationally all that is really required is good team work, a good engine and a reliable model.

Obviously any competitive class will increase in complexity as more thought has to be applied to gaining those vital few seconds to beat the other person, this is alright for the established competitor but must be having a deterring effect on newcomers, and the lack of newcomers will eventually lead to decline in popularity of the FAI class.

Today FAI team racing in this country is probably more popular than ever, whilst on the Continent it seems to be decreasing.



One event that Derek and Malcolm would dearly love to win, but which has just escaped their grasp in recent years, is the FAI event at the British Nationals. Since 1973 a Dutch team has narrowly beaten them – in this picture the visitors in 1975 being on the extreme right – namely Bert Metkemeyer (with model) and brother Rob (kneeling). In third place were Don Haworth and John Horton – the latter holding their unconventional tail-less design.

This is brought home to us by the fact that at every International or World Championship event, the people are nearly always the same. Have you any opinions on this? Does the availability of special parts (and engines) help the beginner?

Admittedly FAI interest is waning in some European countries but it is noticeable that more 'new' countries are now sending teams, e.g., South Africa, Cuba, Brazil, Australia and this is very pleasing. Most countries select their teams by a system that reflects consistency as well as the ability to produce the occasional ultra fast time – this means that the more experienced teams will usually win through a Trials selection, and therefore keep re-appearing at internationals.

There has in fact been a decline in FAI in this country, only the National's entries are on a par with the entry at all the major competitions of 10 years ago. The lack of availability of specialist team racing parts and engines does have a bad effect on newcomers to racing who find that a lot of time has to be spent in both model and engine preparation, unlike R/C where there is a wide choice of readily available engines, parts and models. It is a pity that so many people lose interest in racing before realising that all the special extra's are not mandatory!

Malcolm, as the engine man, do you think that we will soon see yet more efficient motors, or has the development of 2.5cc diesels nearly reached its peak?

There is no reason to suppose that diesels have reached their peak – people once thought that the ED Racer was the ultimate. Since then we have had better fits, and materials, sturdier crankcases and different porting.

The pace seems to have slowed since Schneurle porting, but now we have 5 porting appearing – we will soon be back to 360 degrees radial ports!

Engine development will only continue as long as there are people prepared to fly

competitively and people prepared to make engines. Since Ken Bedford stopped production of the ETA there hasn't been a suitable British engine for any of the racing or speed classes. England has a healthy nucleus of people with experience of both Bugls and Rossi's who would jump at the chance of helping in the development of an English 2.5cc racing engine if only there was an obliging manufacturer around. The availability of such an engine could only increase interest in this class.

We understand that you are experimenting with your own engine. Certainly your 1.5cc motor has proved a real winner – but do you expect to be so successful with the Bugl and Rossi competition?

This is of course closely allied to the previous question, it is very difficult to scratchbuild a competitive racing engine. If the first one does not work, then you have to start all over again and it is quite probable that at the end of the season you will have had no success and still only have one engine. Successful racing demands more than one engine at a time, and the time constraints against making sufficient engines and spares makes it impossible from our point of view. I shall undoubtedly continue to play around with home built engines in a low key manner as we are in the position of using at present, an engine for which spares are difficult to obtain, apart from the fact of being reluctant to 'take a file' to a Bugl.

Very few people seem to be able to improve the performance of a standard Bugl – have you tried? What were the results?

The Bugl is the most consistent and stable engine available for FAI T/Racing but it does need its fair share of TLC (Tender Loving Care). Really the only changes we make are to use a Tufnol choke in place of the original metal one, and we do not use the Bugl all-function valve, or any form of port priming.

What method do you use to run-in a new engine?

Running-in is done in the model, in the air (hence advantage of fuel shut-off!). At the end of the race!

Derek, as the pilot, can you explain some of the difficulties in legally overtaking another model? It seems that so often today pilots take a negative attitude by trying to slow down and block an opponent, rather than concentrate on going as fast as he is permitted. Do you have any solutions to avoid intentional blocking?

Legal overtaking varies with each jury, generally on the Continent pulling your hand quickly over the pilot's head and back onto your chest towing the model along is the accepted method and goes unpenalised, whereas line crossing and waiting for your model to overtake receives an instant warning. Normally in England the juries work exactly opposite to this and therefore the first problem is in anticipating which flying style can be safely adopted!

The basic problem is that of insufficient air speed differential between two models, making it impossible to comply with the 'two laps off chest' rule during a protracted overtaking operation, especially if the pilot trying to overtake is much shorter than the opposition.

I can see no value in trying to slow down or block an opponent since even if you did succeed you are not helping your own chances as there are the other 50 entries still capable of beating your own time, and hence preventing you reaching the next round. There is only one way to win, and that is to produce a faster time than all the other competitors.

The solution is very simple and rests squarely on the juries' shoulders since there are sufficient rules at present which prevent one pilot carrying out any manoeuvre which affects another pilot or model.

Many spectators think that the pilot has an easy life – he just holds the handle and the pitman makes or breaks a race. Perhaps you could explain the other duties of a pilot!

If this were true then pilots would be redundant and spectators would be watching a bigger version of RTP. The main piloting duties were admirably explained in Rob Metkemeyer's article in the October 1973 *AeroModeller*. Briefly these are: to aid the pitman in obtaining the correct setting prior to the race; flying the model smoothly – wandering up and down is slower than straight and level; anticipating the approach of a difficult overtaking manoeuvre and not getting boxed in and allowing the engine to overload; being aware at all times of the relative position of his own pitstop and the other models; delivering the model smoothly to the pitman; flying in a style that meets with the jury's approval.

Our approach to racing is that Malcolm, as the engine man, does a lot of his work prior to the race day in preparing the engine to the best of his capabilities.

Because of the number of years we have been flying now we expect to take a fairly constant time each race over the start and pitstops; this leaves the race to be won or lost in the air. Assuming again that the pitman has correctly set the engine this leaves the outcome of a race largely in the pilot's hands. Luck does play a part, as 49 laps may be flown solo.

Racing is very much a team effort and good results only come through both members playing their part to the full.

When your model lands for a pitstop, how

fast is it travelling – and how far is it from the point of touchdown to Malcolm's hand?

Our best models can be shut-off half a lap from the pitman, i.e., they decelerate from around 95mph to zero in about 1½secs. – suffice to say that on occasions they have been going fast enough to break a wing!

Our aim is to keep the model in the air until less than one segment out – this maintains maximum flying speed as long as possible, and helps to prevent line snagging problems.

Whilst you have dominated ½A and FAI racing, your grip on Goodyear has been falling, especially since the Rossi glow engines hit the scene. Do you take this class seriously, or is it just a fun event? Will you be using a hot glow engine in this class next year?

FAI is taken seriously in that if given the choice it is the one event we want to win, whereas the other three classes are flown competitively on a take-it-as-it-comes attitude. We only started Goodyear racing as a 'fill-in' event and we now use it as a training exercise for FAI, hence we shall probably be staying with diesel power.

Our glow racing is limited to 'B' Team Race which we really do enjoy and are very happy to see that interest in this class is reviving – long may it continue.

Both ½A and Goodyear classes were introduced as a 'beginners' low-cost events. Both failed miserably to achieve this objective. Have you any ideas on a truly beginners class?

½A was an excellent newcomers event prior to the advent of Goodyear and it is a great shame that this class has virtually died through the lack of suitable engines. To this end it was very pleasing to see the recent advertisements to the effect that Oliver Cubs will again be available.

Any competitive class, if it is to survive will show some degree of technical advances but by the very size of ½A models these will be limited, i.e., we do not expect to see retracting undercarriages in ½A's! A standard Cub has always been a very competitive motor in this class and gives it user every chance of success, these motors are relatively cheap and being diesels, still the best for limited tank capacity events. There is no need to worry with either the technology or expense of glow fuels. Assuming Cubs do become readily available, it would only need one other British manufacturer to provide a good quality 1.5cc diesel to bring back ½A as an ideal newcomers low cost event.

Your FAI models are 'prettier' than most – do you favour semi-scale racing as originally intended by the rules, or are you happy with the very stark models that some prefer?

No, the present sophistication of FAI racing has taken it way beyond the original semi-scale concept, FAI models are now pure racing machines and quite rightly so – but this is no 'excuse' however for stark models, we like to build aesthetically pleasing models.

Several times the Russians have proposed 4cc fuel tanks, and several nations have suggested a 1.5cc size limit to FAI racing. What are your views?

We do not see the need for an engine size reduction to 1½cc but would quite happily live with 4cc tanks as this effectively increases the amount of team work –

Emil Rumpel prepares his asymmetric model assisted by team mate Jurgen Lenzen at the '75 European Championships when he broke the Italian domination by topping the results.

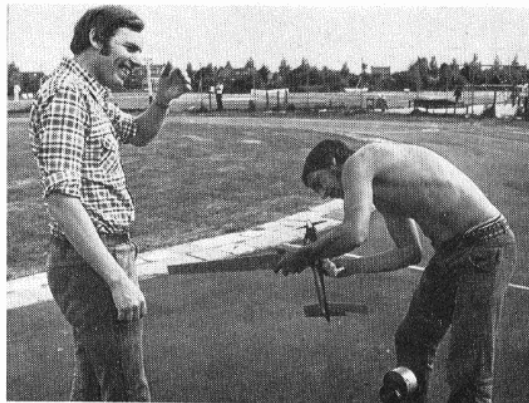

perhaps an alternative would be to increase the length of a race, to say, 140 laps.

Do you think that the FAI event needs a close re-appraisal – and if so, how would you amend them?

The rules are basically OK as they are, perhaps we would quibble with one or two relatively minor points but if the basic concepts of safety and fair play are to apply it is very difficult to see where worthwhile changes could be made. The real problems occur with the many differing interpretations applied, especially to the piloting offences such as hand off chest, whipping and not walking forward properly, in many cases there is a question of degree before the jury considers an offence has been caused and it is this variability in standards which create most problems. The major thing required is a comprehensive, internationally agreed, guide to rule interpretation. If rule changes are required then the hand on chest rule should go, this is too arbitrary a rule at present and is discriminatory – it favours the tallest pilots whose chest is higher than opponents shoulders and in some cases heads! At present it is an advantage to be tall, i.e., the trend for short pilots to wear high heels proves this – this must be wrong when the real aim of the rule is to prevent whipping, not to create a race of 7ft tall pilots!

At every contest, there is always the problem of rule interpretation with regards to whipping or leading the model on overtaking. Would you prefer a return to the old days of legal whipping, or would you prefer the current rules to be firmly enforced?

There can be no future in a return to legal whipping, the answer lies in the code of practice for juries referred to previously, and in more recently experienced racers, especially pilots, being prepared to act as jury men.

Under the present rules, and given a strict Jury, what would you estimate as being the best possible heat time with existing equipment? Assuming the same conditions and rules, what sort of heat time could be expected in, say, five years with the current rate of development?

Really this question is too vague as a lot depends on the luck of the draw as to who you fly against, especially at International level. An easy draw will produce a better time than a hard draw, quite independent of jury's attitude.

Taking three teams flying at 21secs for 10 laps, and staying clear of each other at

pitstops, they should all record 210secs flying time, 2 seconds for the start, two pitstops at six seconds each, i.e., 3mins 45secs total race time.

In five years there will quite possibly be the odd report of 3:30 times from around the world with International semi-final qualifying times down to four minutes – we feel that the semi 'cut-off' time better reflects the progress made as the ultimate time will probably have been set under somewhat favourable conditions.

We feel that Team Racing is the most sport orientated aspect of aeromodelling and the great sense of achievement gained from taking part in a World Championships is well worth the initial effort involved.

It has given us the opportunity of gaining many friends world wide and has taken us to countries we would probably never have visited otherwise.

It is a great sport full of friendly people so why not join in?

EMIL RUMPEL

WEST GERMANY'S WORLD AND EUROPEAN FAI SPEED CHAMPION

For years it was always assumed that no one could beat an Italian speed flyer using an Italian engine, and yet in 1975 and '77 you became European Champion, and in 1976, World Champion a really tremendous achievement. We have noticed that the German team always fly identical equipment and work very closely together – do you find that this 'team spirit' is important in achieving success?

Yes it always looked so – but I am sure the Italians have been taking it easy! From the Rossi factory point of view, it is bad for Italians to always win – people would say that they cannot compete against a "works" team. Although you have published pictures of Mr. Ricci and Mr. Dusi with their friend, Mr. Rossi, there have never been pictures of



Emil leads his model out of the drop-off dolly undercarriage unit as he begins the flight which made him World Champion in 1976 at Utrecht, Holland.

Mr. Rossi with members of the German team, but he has helped me to realise my own ideas.

It is much easier when we all use identical equipment – when I start an engine for Jurgen (Lenzen) or Ingo (Schmidt), it is just as if I start my own engine. All the procedures are the same.

You have been one of the pioneers of asymmetric models. Why did you change to this type of model, and how much speed is it worth compared to a conventional model?

I was not one of the pioneers. I saw Arnie Nelson with an asymmetric model in 1970, then in 1971 I was staying with Arno Wamper at the Namur World Championships, and we discussed this model. Next year Arno had just such a model, and in 1972 I started the *Kingfisher* – but I saw several more models of this type before finishing my own. More speed? I do not know; they fly better – like a hammer! When flying the outboard wing has to travel faster than the inboard, so reducing its length reduces the drag.

Your models feature an upright-mounted engine, yet the Americans and Italians – your closest rivals – choose side winder layouts. Do you have any good reason to stay with the upright engine?

With the side winder it is very difficult to get the engine exactly at zero degrees of incidence, and plus or minus 1° error in alignment means throwing away all speed.

The models which you fly are superbly made, and feature wings with a balsa core over which aluminium sheet is wrapped. Does this use of aluminium increase the total weight – and does it produce a stiffer wing?

The aluminium alloy makes a heavy model. My World Championship wing model weighs 495grams – just under the FAI limit. However, the wing is very stiff and will not flutter even if speeds top 300km/hr.

A Kingfisher asymmetric speed model under construction reveals its basic nature. This model built by Gordon Isles predates the metal skinned versions now more popular. Plans available from Aero-modeller Plans Service – Order No. CL1259, price 70p including post.

How long does it take you to build a new model? Do you have any special building techniques?

I never build a single model. Using jigs to speed assembly, I never make less than five at a time. This year I intend to have 12 models built before the European Championships – they were started in January and will be ready in July. I only spend a couple of hours a day on model building, but the models are in fact very simple, with only four main parts – wing, tail, fuselage and pan.

The Rossi engines that you use are prepared by Rolf Miebach – basically, what modifications are made to the engine, and how much extra performance do they give?

Yes I do use Miebach prepared Rossi engines. What does this mean when Rolf prepares the engine? He tells me 'you must do this and this to the engine', and I do it. Then we get together and run the engine and say yes, this is good, you can fly with this motor! But when I have a problem I can phone Rolf and describe the symptoms (perhaps it will not run clean, and I cannot find the needle setting), and he says you must do this or this – and then the problem will be gone. You can be sure he is right.

Modifications? The exhaust timing is raised to 180–185 degrees and the liner lifted 0.2–0.25mm and we make our own pipe. This is in one piece – no separate header pipe – to prevent us from making mistakes. We know the length we want, so soldering the sections together prevents leaks. We have different pipes for varying weather conditions.

Do you find that the ABC Rossi is any faster than the steel liner version? Have you ever experimented with the rear-valve Rossi?

We have flown an ABC Rossi for three or four years now. We have not tried the rear-valve Rossi because it has one moving part too many!

For many years you have persisted with the centrifugal force operated fuel switch to provide sufficient fuel for the engine when it is 'on the pipe', despite seemingly many early troubles. Do you find that this system (also Rolf Miebach's idea) is more reliable than the more popular straight suction feed or pipe pressure?

We have not had trouble with the CFS – and I have been using them since 1972. I think that it is the best system for speed flying as you can find the ground setting by adjusting the fuel switch, and find the air setting with the needle. When the model is in the air, only the needle needs adjusting – you can set it two years beforehand! The switch is only operated on the ground and its only function is to get the model off the dolly and into the air.

However, with a dolly switch there are two critical moments, which occur at the same time. The first is as the model leaves the dolly, the second when it is actually flying. When does the switch open? Does it give more fuel to the engine in the air or in the dolly? It depends on the strength of the spring.

Over the years we have seen several different single bladed props used – do you think that more speed can be obtained with this development?

Maybe in a few years, but I am not interested in trying them yet. I have a few single-bladed props and perhaps I will test them, but I will use a two-blader at the '77 European Championships – and the '78 World Championships.

What type and size of propeller do you use? Do you spend time washing out the tips and checking the pitch accurately?

How often must I tell it! I use a Puntilio 6×6in with the tips washed out, and the pitch very accurately checked. This takes between 30mins and an hour. However, only my engine will run with this prop. Another engine and I must make another propeller.

Competition is very close at the top now: where do you think the greatest single improvement will next come from – propeller improvement, model design, tuned-pipe research; or a more powerful engine?

Propeller? A single-blader might give a little more speed. Model design? No. Tuned-pipe research? No. I think the current Rossi is probably at the peak of its development. Perhaps there will be a new Rossi, or another new, better, engine – but at the moment I cannot see one on the horizon.

How soon can you tell if the engine is going to be good? Do you have a special test propeller – and if so, how fast must the engine turn if it is to be competitive?

After modification of the engine as previously described, the engine is run on a standard test prop and pipe. It must reach 31,000rpm if it is to be competitive – and nearly all our engines reach this figure. Last year we prepared the engine for Bas Buser of the Netherlands – he also uses equipment similar to our own. His motor peaked at the same rpm, but my engine will take a little more pitch. Why? I don't know.

Providing there are no rule changes, how fast do you think that it will be possible to fly, in say, five years time?

If the rules do not change, then 300km/hr is possible – because the current rules do not ban magnetising the lines to reduce drag. I think the Italians, Americans and Russians are working on it. The Russians are reaching 260km/hr – and they must be magnetising the lines to achieve this. I think

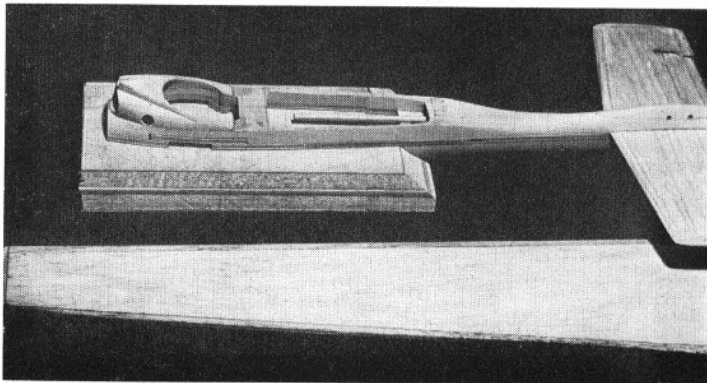



The 'Old Bear' as his team mates affectionately call him – Bob Gieseke – with his famous modified Nobler when he won the World Championships title in Czechoslovakia. Absence of his familiar pipe is explained by the fact that he buried it in the stunt circle!

the rules should state that there must be a distance between the two lines at the point of exit from the model of, say 5–10mm and allow a team race style handle grouper, which does not affect speed. Then we would have conditions similar to the '76 World Championships, where we had a Gentleman's Agreement with the Italians not to magnetise the lines. You could reach 250–255km/hr like that.

With your current equipment, what would you estimate is the highest possible speed which could be obtained?

I made 263km/hr in 1975 at Bochum – but I think the lines must have been a little magnetised and were lying one behind the other.

Should there be a large increase in speed obtainable (say 15km/hr or thereabouts) through the availability of a new super-powerful engine, it seems likely that the FAI rules would be modified to slow the models down again. Should this situation arise, how would you recommend slowing the models without killing interest in the sport?

Make the models larger – say 10 or (like team racers) 12 square decimetres wing area. Keep the 0.4mm lines and do not ban pipes. The engine capacity should not be reduced, as in 10 years time the same speeds would be achieved with 1.5cc. What then? 0.75cc? No. 2.5cc should be the FAI engine for many more years.

For several years now one engine – the Rossi – has totally dominated FAI speed contests all over the world. At the same time, there are now probably more people flying in this class. Do you think that this one-engine domination is bad for the sport or does the ready availability of a contest motor mean that everyone starts off on an equal basis?

It is good that a competitive engine is readily available – then everyone has the same basic start, and can use their own ideas to modify the engine. Since the Rossi was produced and sold all over the World, interest in Speed flying has grown rapidly.

The Rossi is not really that special – you could fly speed equally well with a Cox or Super Tigre X15. They are all basically the same, it is just that many more people have worked on the Rossi, and I am sure that next week when I start to prepare an X15 F.I. (not the rear valve, too many moving pieces remember!) that it can be brought up to the same speed as our Rossi. The Super Tigre is well made – the only problem is that it cannot turn a large propeller. This engine works at a higher frequency (32,000rpm in the air) but it only turns fins pitch props.

BOB GIESEKE

THE 1974 WORLD AEROBATIC CHAMPION

Bob, when you became World Champion in 1974, it was as if everyone present willed you to win. You seem to have been so close so many times before that everyone agreed that you deserved the title – and finally everything clicked into place and you topped the results. Just how long have you been flying control line aerobatics, and for how many years have you been flying at International World Championships level?

I have been flying control line since 1942, then started to concentrate on stunt in 1959

first competing at a World Championships in 1964, where I was placed ninth (in Hungary). Flew my first plane successfully on my tenth birthday: Dad was tearing up too many models and for a birthday present he let me try. He never tried again! He was my igniter.

Your bright red Nobler is about as famous as your pipe – when did you first start flying this design, and how does it differ from the Topflite – kitted Nobler?

Built my first Nobler in 1959 but the first modifications weren't made until 1964, when I used a thicker wing. That first Nobler was red – the last one is red! The thicker wing was the first change, but then the flaps got cut down and then the fuselage was changed along with slight nose moment changes.

With the current trend towards bigger engines and bigger models, do you have any plans to change designs, or even enlarge the Nobler?

No bigger – in fact I have found that smaller is better. My new ship is 48½ins wing span (standard kit has 50in span) and my friend Joe Musumci also has a shorter wing version that flies equally well, particularly in the wind. That is with a Fox 35 for power of course.

American stunt models always stand out from the crowd due to the superb finish: the models always look new. How do you achieve such a good finish – and what does it cost in weight?

I use Aero Gloss products entirely, and cover with Jap tissue. No filler coats are used at all, but I do use one or two coats of silver sanded down as a base however. Total finish usually weighs 4–5 ounces including the paper covering. My finishes are not as good as others however, really not comparable to, say, Bill Werwege.

Perhaps even more important, how do you retain the 'as new' appearance – do you use any special de-greaser, and do you carry out a lot of 'maintenance'?

Not much maintenance is called for, I just use a household cleanser such as 'Pledge' after each flying session, and the model only gets a real wax polish once or twice a year.

How much practice do you put in? Do you practice with a 'spare' aeroplane, or do you concentrate on flying your No. 1 contest ship?

I fly only the plane I hope to use in competitions, and I like to get in about 300 flights per year. Actually at the present time I am flying an older ship but this is just to break-in motors and bring my flying up to snuff. However I will be flying the new one again shortly.

Most stunt pilots have a favourite fuel tank system – what do you use, and why?

Tank is a Veco 4 ounce stunt tank with muffler pressure – this runs good. The muffler pressure gives a little steadier run.

For several years you have remained faithful to the Fox 35. What features of this engine particularly appeal? Have you modified it in any way?

No modifications as such, just good round pistons and sleeves. New for this year is the harder piston and sleeve which are now available on special order direct from Fox. The older ones were very soft and did not last too long, but the newer variety are much harder and rounder. Result is much more power, and better steadiness to the

run. I like the 4-2-4 cycle run. Not only does this motor go into a two-cycle to help you with power, but it also goes back into a four-cycle to 'brake' the model. Many others have attempted to duplicate the Fox run, but so far none have. They have duplicated the 4-2 cycle but not the 2-4 cycle part! A Fox will actually slow the model down as it dives, but the other models will continue at a rapid rate with only a coasting effect at most. I like brakes as well as something that pulls you across.

Do you favour the current flying system at World Championships, i.e., whereby the top fifteen fliers from the first two rounds go forward to a two round, both to count, flyoff?

Yes, I was one of the people who wanted this system put into effect. Actually this way the judges get to see the better fliers close together and can come up with a better job. Seriously, if the judge has to look at one good flier then five average fliers before another good pilot, then he has a difficult time. But if all the good ones are flying together it is much easier for the judge to select the right winner.

Surely, every flier at a major contest round must at some time come across the situation when he feels that either he or someone else has deserved more/less points than the judges have awarded. Are you happy with the current standards of judging, or have you any recommendation to make concerning judging aerobatic contests?

I feel that judging is a very difficult job; I have judged pretty much and don't really like to do it. Unfortunately, so far it is the best, and only system we have. Would like to see it done with photography however, like instant replays on TV, and this with a grid system for a background might change some of the results.

This would be expensive, but it would be the best. Of course, the camera distance would have to be taken into account along with line length and the size of the grid, but it could be done. Judging schools would help some.

American fliers have dominated World Championship events for many years. Why do you think this should be: are your teams members more dedicated, or is there stronger competition back home?

Both are right I think. Our team Trials are very hectic, to say the least. It seems so hard to get on the team here with so many good fliers available: I have to work much harder to get on the team than at any other time. I like to use the Nationals for a warm up for the team Trials – not that I win them every time, but it does get you going for the Trials. Personally, I would like to go to the Nat's just before leaving for the World Champs – it would certainly make me much better. Also, how many times at the World Champs do you see the Americans flying till dark? Every one of them – no other country is out there missing the evening meal like we are. We always get back to the hotel when the rest are cleaned up and done eating. I really do believe that we try harder.

Do you have many US aerobatic contests to keep you 'on your toes', or do you have to rely on intense practice flying to keep up your standards?

Intense practice plus the Nat's is about all I do. Local contests are hard to do for me with my work schedule and all. Also, by staying home I can get many more flights

More easily recognisable thanks to that pipe, Bob fires up his trusty Fox 35 an engine which is unique in producing a 4 - 2 - 4 cycle run. He'll stay with that motor until another one appears that can beat it.



per given weekend than spending my time travelling. A 'close' contest in Texas is about 150–200 miles from home. We do have 2–3 contests in the local Dallas-Fort Worth area though.

Turning back to the 'hardware, we already know that you favour the Fox 35, but what fuel mix (and what type of oil) do you use?

Always Fox Superfuel, which has 5 per cent nitro, 29 per cent castor oil. Synthetic based fuels ruin a Fox.

What weights do your Noblers turn out at, and do you find that you have to adjust propeller sizes to match each different model?

40 ounces I like, but I have flown them up to 45–46 ounces – not with any real success though. Generally, my best results have come with them weighing around 41–42 ounces. Under 40 ounces with a regular ship is too light. Don't mess with props too much – actually I do a lot of prop testing early in the year and then settle down to the 10×6 Rev Up every time! At present I am using a newer Toplite 11×5½ins cut to 10½ins diameter with good results. Actually I trim the motor by using more or less headgaskets. The motor must be trimmed to the model or else you don't gain the full advantage of the Fox run.

What method do you use to ensure that you do not suffer an over-run at the completion of a flight schedule?

Careful timing of the practice flights. If needed I drain some fuel from the tank. However that is not usually the case as I am nearly always about right with the 4 ounce tank. In the past though I have added white gas (petrol) to the fuel to extend the run: around 1–2 fluid ounces per quart will lengthen the run by 30–45 seconds. Mainly rely on careful needle setting and timing at the contest site.

Have you ever considered using throttle control on a stunt ship? Some of the scale fliers are getting pretty good response from closed loop R/C type control fed down the control lines: could this be a good development?

No! Although it is possible, I like things simple. The simpler the better – and the less chance of error. I would be against anything that makes the lines larger or heavier.

How important do you regard lead-out rake is to a model's performance? Do you use an adjustable system?

Very important. My lead-outs are adjustable, in fact they are *individually* adjustable. This way you can adjust for either one of the lines.

Do you consider that aerobatic flying is in need of a new shot in the arm? If so, what changes would you make?

Not really. We are still a long way from flying the perfect pattern and until many people can do it perfectly, I am satisfied. Undoubtedly better planes *can* be designed, I think. If we could get more controlled motor runs with more power we would be on the way, but so far no one has one. It will show up someday though. . . .

Which manoeuvre in the current FAI schedule do you consider the most difficult to perform correctly every time?

Every one is difficult to do properly. Even good level flight is tough. I usually give away the wing over and overhead eight though as the slow motor run will just not allow these to be done properly. My competitors will say I give everything away with these slow motors however! Actually the most consistently bad manoeuvres you will see are squares, including the eight, the hourglass and the overhead eight.

The most important thing to do in this event is to have a light, 'straight' ship with a good running motor. Then you need the practice, with someone who will devote their time to you and help you with the figures.

Finally, do you have any basic advice for would-be serious stunt competitors?

None of the previously mentioned points are any good without the other. Each is as important as the other. Each person has their own style that they should use; it is no good trying to competely copy someone else. You do need to learn the right procedures, etc., but the individual should use his own resources to determine what is right for him. In other words, just because a person wins one year with a white plane you do not have to build a white one, or because a Super Tigre 46 wins one year, then you have to build one with a '46'. That is *not* important. Developing your own personal style and winning combination of motor, airplane and something you can live with, and be happy with, is much more important. You gotta have something you like to practice, as much as the need to win. If you do not like your plane combo, you will not devote the required time.

Mini Slow

designed by
DAVE CLARKSON

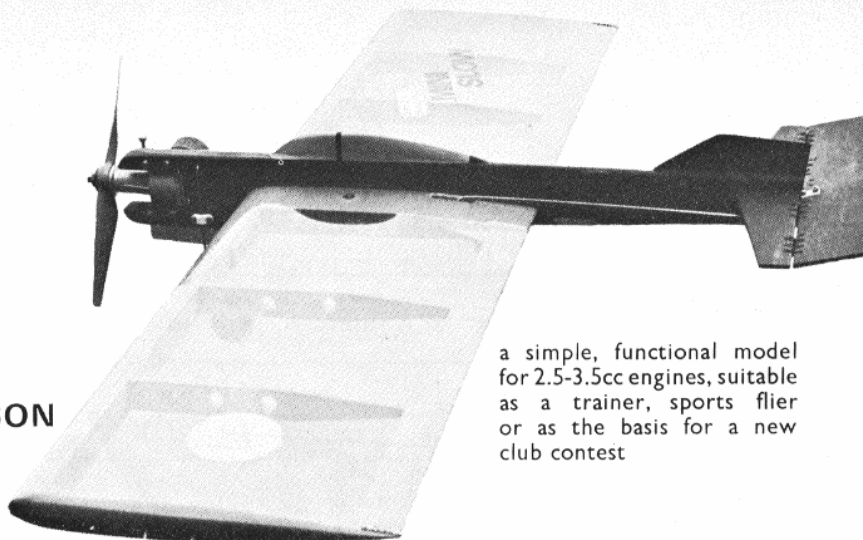

a simple, functional model for 2.5-3.5cc engines, suitable as a trainer, sports flier or as the basis for a new club contest

'MINI SLOW' arose out of a desire in the North West to create a type of fun contest where all control line modellers, whether they be combat, stunt, speed or racing fanatics – or just the average Sports flyer – could compete together on an equal basis. The rules were eventually established on the following principle:

Each entrant, on his own except for one assistant whose only function will be to hold the model when so requested, shall fly his model a set number of laps from a 'LeMans' start. The entrant will re-fuel and re-start his model as necessary to complete the lappage required. The number of seconds taken from the start signal to the race completion shall be recorded. During this period, a set schedule shall be performed and these will be subject to simple judgement. Completion of each manoeuvre will gain a bonus according to the excellence of the manoeuvre. The total bonus points accumulated during the race will be subtracted from the flight time in seconds to give the final score. The entrant with the lowest score will be the winner.

A simple principle in which neither models built for great speed nor great manoeuvrability should be unduly favoured, and which requires entrants to be competent both as pilots and pitmen and, for success, to be physically fit. So that all models would be comparable and yet allowing some room for design innovation, the following model rules were adopted:

Motors 3.5cc maximum
Lines 52ft 3in from centre line of handle to centre line of model. Three-strand lightweight steel lines only.

- Tanks** 30cc commercial 'stunt' type only. No 'quick-fills' or pressure systems. Squash bottle only filling.
- Propellers** Commercial nylon props only.
- Wing** Minima: span 30in
area 250 sq in
thickness $\frac{3}{4}$ in
- Fuselage** Profile type (max. width $\frac{3}{8}$ in excluding tank and optional nose side check). Minimum length 18in from elevator hinge line to motor prop driver face. Tank must be entirely in front of the wing. No motor cowling from motor mounting lugs up. Must have fin and canopy of reasonable proportions.
- Undercarriage** Minimum requirement of a fixed mono-wheel undercarriage that allows unassisted rise of ground. Minimum wheel size 1in diameter.

To complete the rule package (except for pilot conduct and safety requirements), the race distance was set at 80 laps and the manoeuvre/bonus points schedule was fixed as being:

| Type | Bonus Points | |
|------------------|--------------|------|
| | recognisable | good |
| 1 loop | 10 | 20 |
| 1 horizontal '8' | 10 | 20 |
| 1 vertical '8' | 10 | 20 |
| 1 outside loop | 10 | 20 |
| 1 wing-over | 10 | 20 |
| 1 overhead '8' | 10 | 20 |

The simple structure not only speeds assembly - it's cheap too! Resulting aircraft may be flown as a super-smooth, stable trainer or as a high performance sports/club contest model. Our version weighed 18 oz complete with Fox I9, silencer and all hardware. If you want a longer engine run, make up a deeper fuel tank.

Two of the original 'Mini Slows'. Dave Wiseman's version (top) used an experimental wing structure with built up leading and trailing edges, but it proved too weak. The designer's model however is still in one piece! Power is supplied by an MVVS diesel.

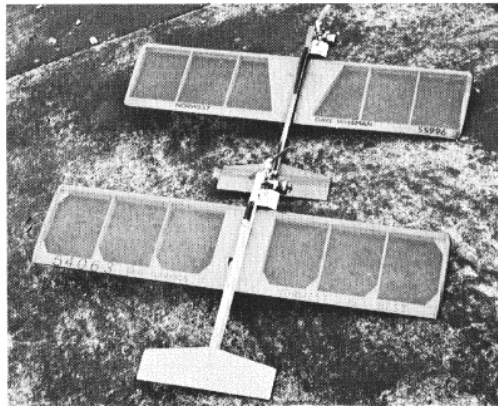
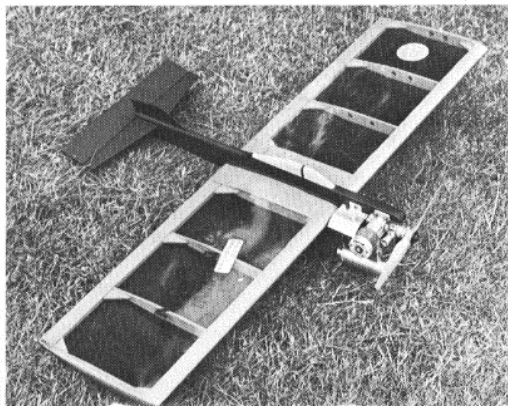

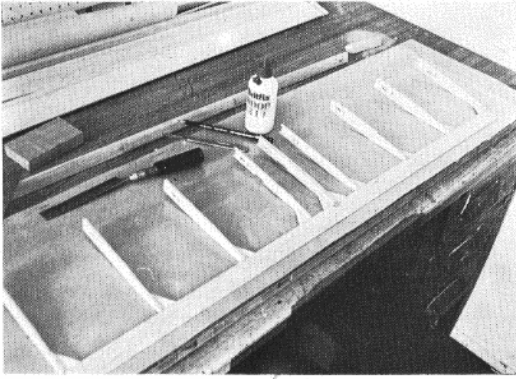

First stage of construction. The trailing and leading edges were marked with the rib positions, then the former item was pinned to the building board before the ribs were added. As the ribs have a 'straight line' section, they too may be pinned to the board resulting in a warp free structure. Add the gussets to reinforce the rib joints.

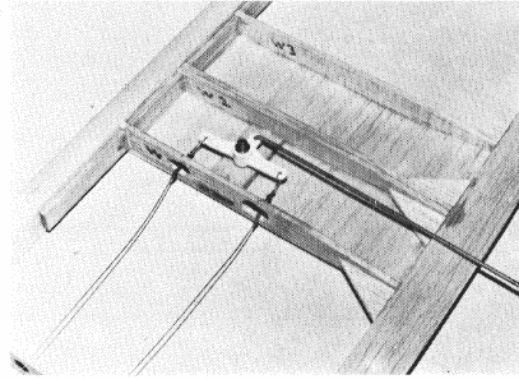

Close-up of the centre section reveals the spruce reinforced leading edge and bellcrank mounted on its ply platform. Bellcrank shown is a Micro Mold item, as a Veron item (shown on plan) was not locally available. Pushrod is retained by a soldered cup washer. Use heavyweight control line wire leadouts - bind the looped ends with fuse wire and solder.

Obviously each race was a solo affair and, despite the apparently simple and basic requirements, a rather exciting event too!

Mini Slow was conceived to fit these requirements and also designed to be about as quick, easy and cheap to build as possible. The plan and these instructions reveal just how this meets the bill, while the photographs reveal that it is not *that* unattractive, despite its basic form! However, unless you build one yourself, you will never know how nice it is to fly and how manoeuvrable it can be - a good pilot should be able to fly one without much difficulty through the entire SMAE 'stunt' schedule, producing at least recognisable manoeuvres: squares, triangles, overheads, the lot! To just about everyone's surprise, *Mini Slow* has turned out to be an ideal Sports model, because by just varying the elevator throw it changes from a really docile trainer into a fully manoeuvrable stunter. Just right for your first 'real' model after a basic trainer.

Construction

The wing, tail and fuselage are very simple structures and do not come together until a final assembly operation prior to finishing, therefore simultaneous construction of all three components is possible, and is recommended, for speed of construction. Start by cutting out a complete kit of parts (you should find the wood list on the plan quite sufficient despite its brevity) so you can be gluing one part whilst another is drying. This way, building time is reduced to an evening or two.

The wing is based on a pre-shaped $\frac{3}{4}$ in deep leading-edge section and a pre-shaped $1\text{in} \times \frac{1}{4}$ in trailing-edge section, both being held apart with the minimum of simple 'ruler section ribs'. First cut ten ribs to the W1 profile, then trim four of these to the W3 profile - then notch three of these for the bellcrank platform to give one W3 and three W2's. Glue two W2's together to give the centre rib. Using a worn $\frac{1}{8}$ in drill, drill the leadout ways through the inboard wing ribs. Now trim the leading and trailing edge sections to length, pin the trailing edge to your building board and glue the ribs to it, making sure that they are square to the trailing edge. You should find that, with the trailing edge pinned flat to the board and with the lower rear portions of the ribs also pinned flat to the board, the upper rear surfaces of the ribs and the trailing edge also form a straight line. Before the glue sets, add the trailing edge/rib joint gussets and allow to dry. In the meanwhile, accurately position and glue the 8in length of $\frac{1}{2}$ in \times $\frac{1}{4}$ in spruce to the rear face of the leading edge section, and cut the bellcrank platform to shape from

$\frac{1}{2}$ in ply. When the rib/trailing edge glued joints have dried, remove the pins holding the frame to the board and then re-pin the frame to the board so that the lower front portions of all of the ribs are flat on the board. Do this with the wing 'upside down' so that after gluing and pinning into position the leading edge section, the bellcrank platform can be added. Whilst the leading edge and bellcrank platform/rib joints are drying, make-up the tips from 8in lengths of $\frac{3}{8}$ in sq balsa, not forgetting the in-board tip for the leadouts. Once assembled, the tips can be glued to the board and the leading edge/rib gussets and lower centre section sheeting added (note that the centre-section sheeting goes over the trailing edge, so as to provide additional strength here). Once the glue on the wing frame has completely dried, it can be removed from the board and the controls installed, followed by the upper centre section sheeting. The wing is now complete except for sanding the tips to shape, and sanding down the bumps gently off the completed structure, both of which can be done now.

Unless you happen to have a suitable piece of $\frac{1}{2}$ in sheet balsa lying about, the fuselage comes cheapest from two lengths of $\frac{1}{2}$ in sq balsa. The $\frac{1}{2}$ in sq balsa route is preferred because the horizontal glue-lines you build in add to the strength of the fuselage, as does the ability to use, as directed on the plan, strips of different grade. If you adopt this recommended strip method, cut four $16\frac{1}{2}$ in lengths of $\frac{1}{2}$ in sq balsa and glue them together with the harder two strips in the middle. Before gluing the strips together, notch the underside of the top strip at the rear for the tail. Once the glue has set, recess the front at the top and bottom for the bearers making sure the bearer spacing exactly suits your motor. You may require a strip of balsa packing on top of the bearers if using an engine with a narrow crankcase. Now glue in the bearers, holding them in place whilst the glue dries with strips of adhesive tape. If you are careful, the fuselage top and bottom can be shaved to profile whilst the bearer glue is drying. Once the glue is dry, the wing hole can be cut - the central fuselage glue line makes a very useful reference line for ensuring that the wing hole is cut to give zero wing incidence. Check that the wing is a neat fit in the wing hole, then remove the wing, sand all surfaces on the fuselage smooth and glue on the ply nose and wing trailing edge position doublers. Now give the fuselage a coat of dope, then dope tissue onto the top, bottom and sides of the fuselage. Finally, slot the fuselage rear for the fin and cut to shape and glue in place the ply fin and laminated $\frac{1}{2}$ in balsa sheet canopy, plus tail skid.

The tail is cut from the remainder of the $\frac{1}{2}$ in balsa sheet the wing ribs and gussets came from. Note that the taper

on the tail leading edge is made by gluing the triangular sections removed from the tail outer portions to the inner portions in order to save wasting expensive balsa.

Once this bit of gluing is dry, sand the tail to a symmetrical section, i.e. round off the leading edge and taper from both sides the trailing edge, and then give a coat of dope, followed by lightweight tissue doped on. When the dope has dried, the elevator can be cut off, the hinge edges sanded round and the elevator sewn back onto the tail using Keil Kraft 'Supercord' control line thread.

Assembly

If you are going to cover the wing in plastic iron-on covering, your name and SMAE number can be written, using a felt-tip pen, onto the bare balsa of the wing frame before covering, giving permanent model identification and saving a few pence on transfers. Transparent plastic iron-on covering is recommended because it is quick, easy, attractive and light in weight. Easy wing de-warping is also possible should any wing warp creeps in during the model's life. (There should not be any warp to start off with if the 'built on the board' method described for the wing is followed).

The wing may be covered after the fuselage has been added, but it is far simpler to cover it first. Start on the top side and 'tack' the film to the perimeter of the frame with a domestic iron. The correct heat setting for the iron can easily be established by putting it on the silk/rayon setting and then, after it has fully warmed up, dropping a piece of film (less the transparent backing) onto the sole. The film should quickly wrinkle up, but *not* melt. Adjust until this setting is found.

It is easiest to tack the film onto one tip then stretch it taut and tack it onto the opposite tip. Then work down the leading and trailing edge, making sure that the film sticks well and without making 'creases'. Ignore the slackness and wrinkles at this stage. Wrap film over the trailing edge and tack down for approx. $\frac{1}{4}$ in. Trim off the excess film at leading and trailing edge using a straight edge and sharp blade, but leave extra at the tips.

Now for the tips. Pulling the excess material around the tips, smooth the film over the tips – a little practice will show that it is quite easy to avoid creases. Trim off with a sharp blade.

Next step is to shrink the covering tight. Starting with the iron held *just* off the surface of the film start the shrinking process from the centre of the wing working out to the tips and across the chord, working slowly and

carefully. It may be necessary to increase the iron's temperature slightly – but be careful not to melt the film. If preferred a hot air gun – or a hair dryer with a few of the air holes in the rear blocked off to increase the temperature – can be used to shrink the film tight. Take your time and a good result will be achieved, but like any other form of covering, a certain amount of technique is required.

When the film is taut, turn over and cover the other side in the same manner, but do not take the covering over the trailing edge – just trim it off flush. Make sure that at the leading edge the film overlaps by at least $\frac{1}{4}$ in.

With the wing now covered, run the iron over the film at the centre sheeting – touch the film lightly with the iron to make sure that it sticks to the balsa properly. Now, using a very sharp blade, cut through the film at the centre line to remove a strip $\frac{1}{4}$ in wide where the fuselage will sit – this is so that the fuselage can be glued directly to the balsa and allows a $\frac{1}{4}$ in wide area either side of the fuselage for a glue fillet. Do not cut too deeply or else the balsa will be weakened

Glue the wing and tail into the fuselage, making sure that all three are square to one another. Use epoxy for the wing fuselage joint, and run a moistened finger down the glue line to form a smooth fillet.

With the wing covered, the fuselage and tail can be painted some nice colour(s), if you like, preferably using Humbrol matt enamel. The matt enamels have good colour coverage in one coat, are not affected by subsequent fuel-proofing (RipMax 'Tufkote' is very good for this) and because of the matt surface, hold fuel-proofer better reducing the possibility of runs when applying fuel-proofer thoroughly. Application of fuel-proofer will give a gloss finish. When the paint and then the fuel-proofer has thoroughly dried, trim the push-rod to length, and bend the end and then install a moulded nylon elevator horn – seal the horn in place using epoxy glue – making sure you have equal up and down at around 30° each way. Then make-up the leadout loops to give equal leadout projection at neutral elevator. Your motor, tank and undercarriage can now be installed (add tip skids as per photograph if you intend to fly over tarmac) and your *Mini Slow* is finished.

Trimming and Flying.

With a bit of luck, the centre of gravity should come out naturally about $\frac{1}{2}$ in to $\frac{3}{4}$ in back from the wing leading edge, and no ballast to achieve a CG in this range should be necessary. If this is one of your first models, ballast to

When adding the centre section sheeting, note that it extends over the trailing edge. Also make sure that the pushrod hole is of an adequate size to prevent binding - kink the pushrod itself to clear the sheeting neatly. Solder or epoxy the nut on the bell-crank pivot to prevent it from unscrewing due to engine vibration. Ensure leadouts do not snag on the rib.

The major components may be finished separately before final assembly and paint scheme. Fuselage has ply nose and trailing edge reinforcement - do not neglect these. Tailskid is retained by nylon patch. Drill all holes for engine and undercarriage mounting at this stage. Note that both tailplane and fuselage are tissue covered and doped by this stage.

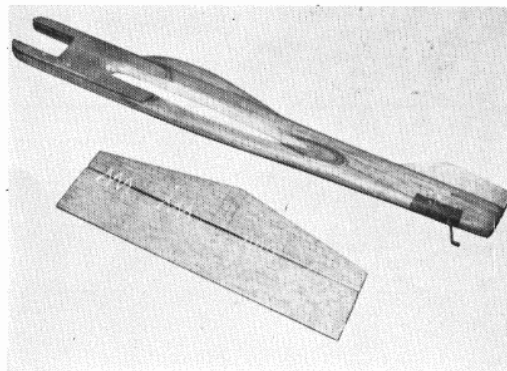
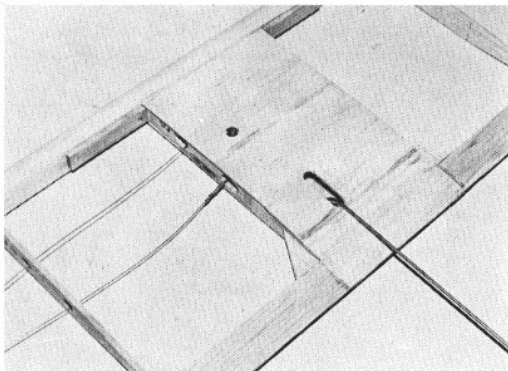

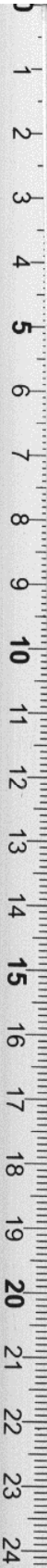

Scrap balsa infill may be needed on top of bearers, depending on engine width

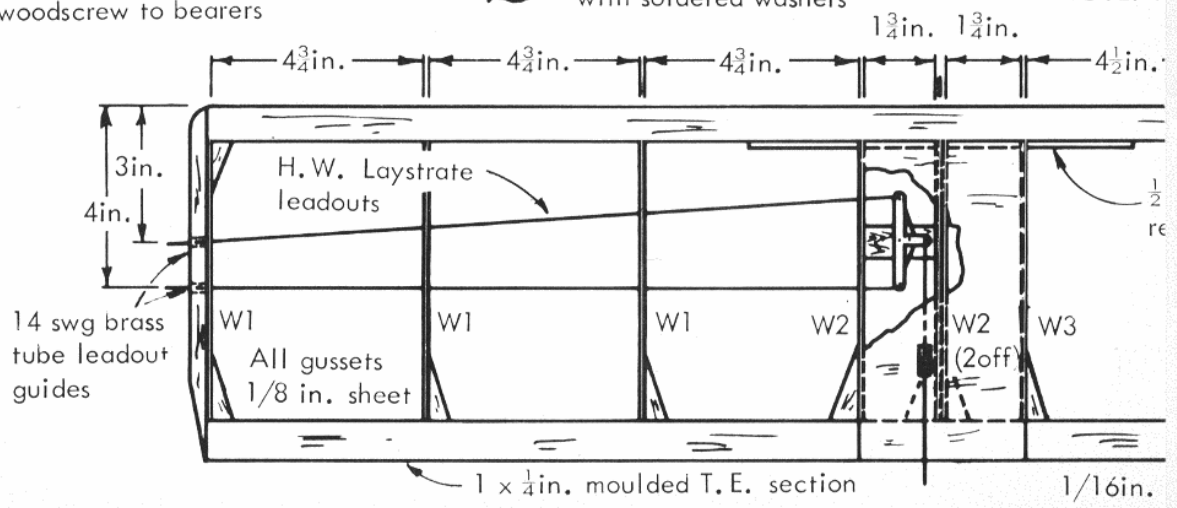
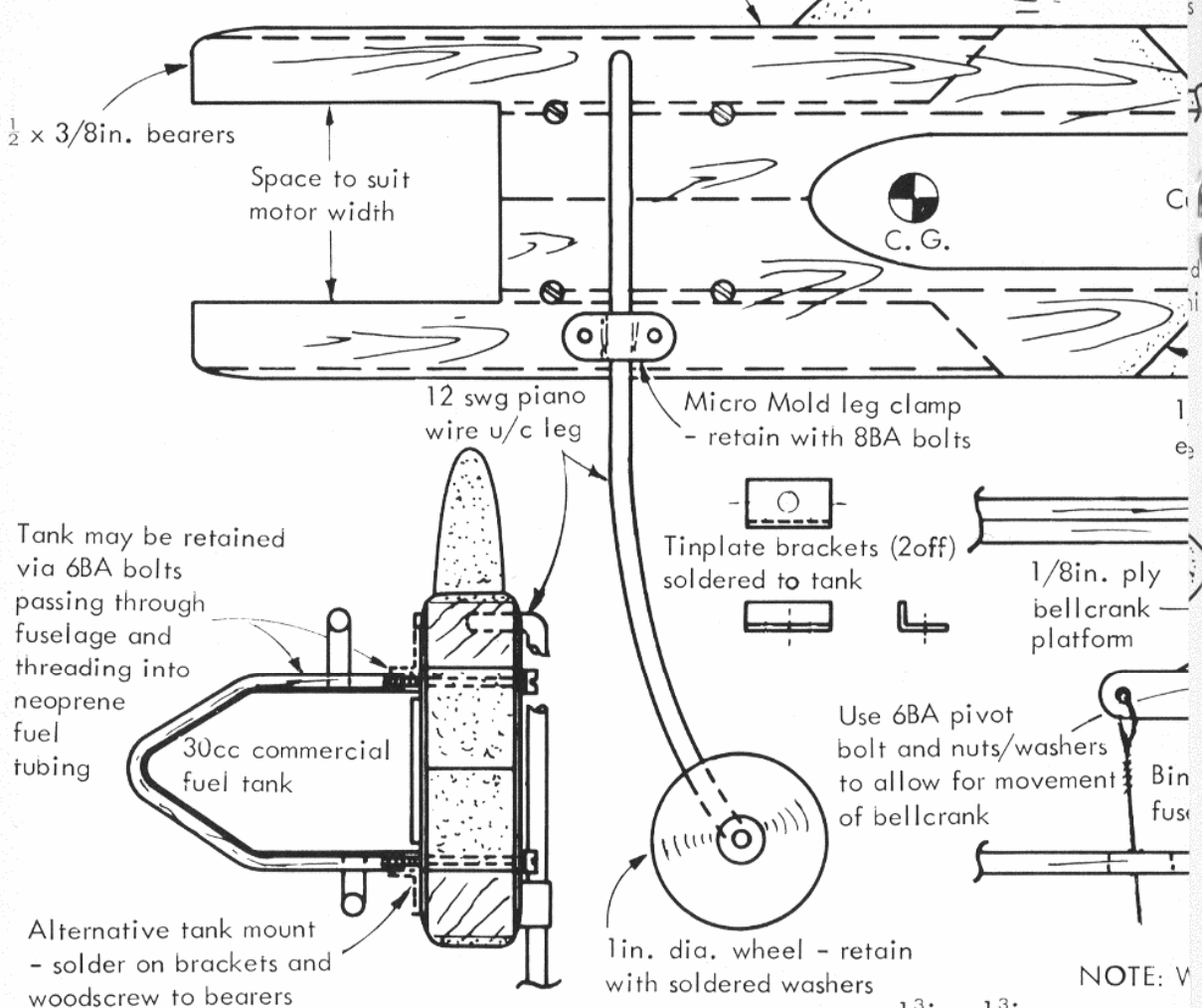

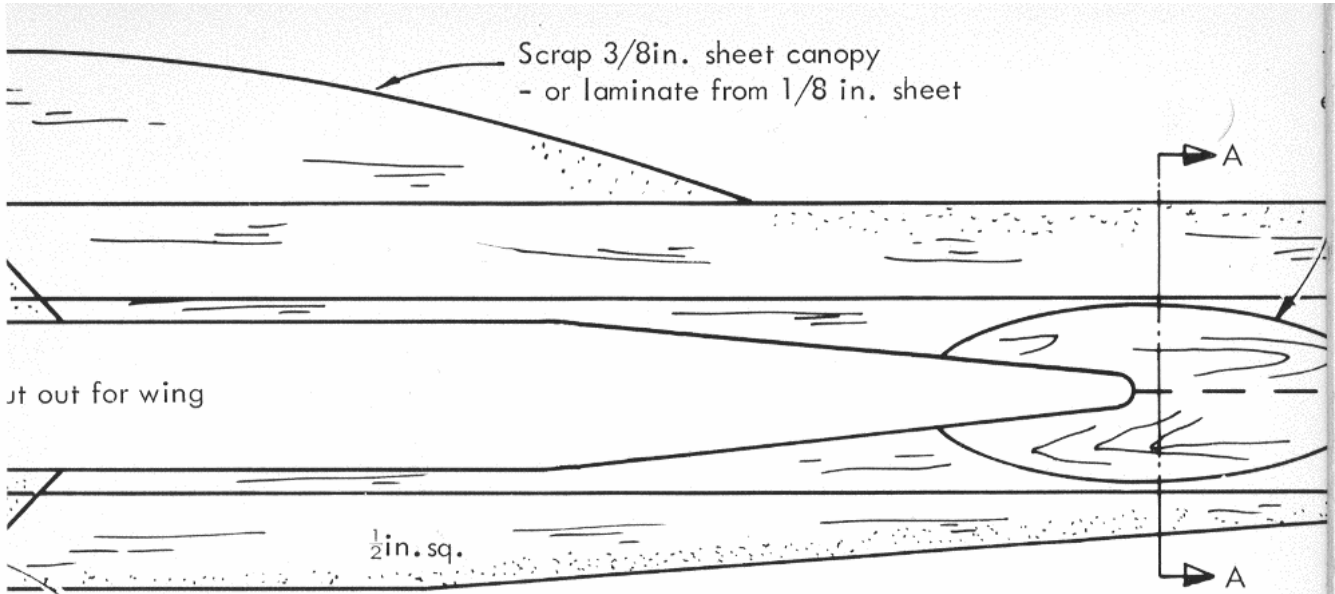

cut out for wing

1/16in. ply doublers
extend back to here

Retain end of pushrod with
soldered cup washer

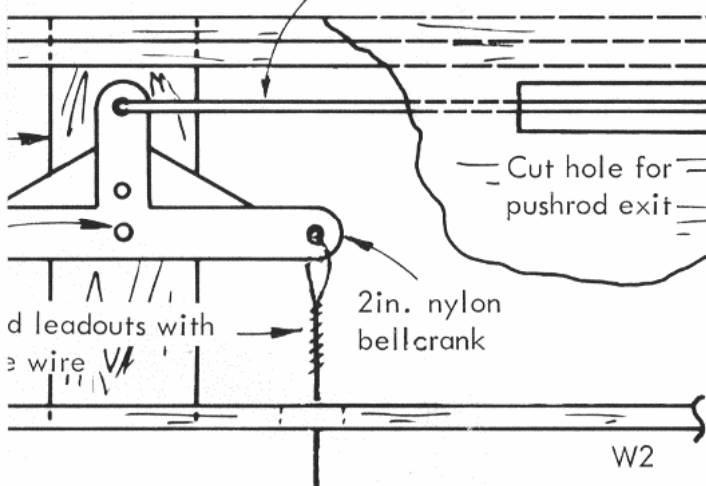

Section A-A

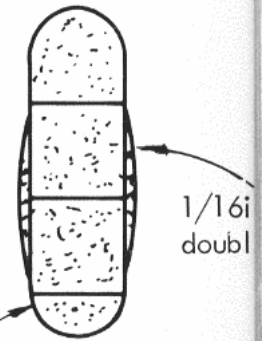

Note fuselage laminated
from 4 pieces 1/2 in. sq.
balsa - or cut from 1/2 in.
sheet

WING DRAWN QUARTER FULL SIZE

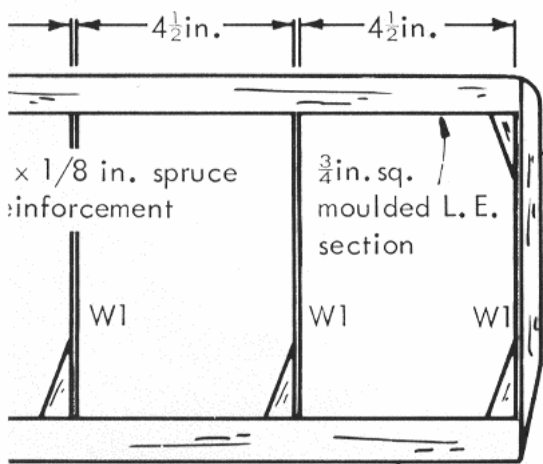

Tips laminated
from two pieces
3/8 in. sq.

centre section sheeting

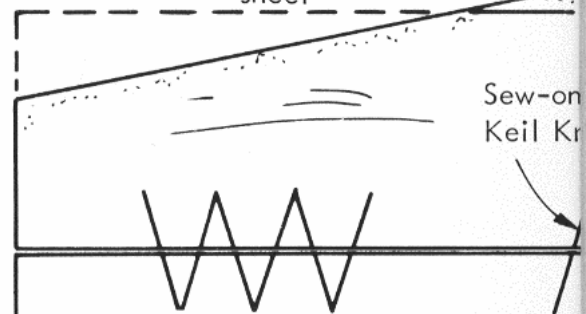

MATERIALS

- Leading edge - 1 off 3/4 in. shaped L.
- Trailing edge - 1 off 1 x 1/4 in. shaped
- Tips - 1 off 3/8 in. sq. soft
- Centre section - 1 off 1/16 x 3 in. s
- Ribs, tail, gussets - 1 off 1/8 x 3 in. me
- L. E. reinforcement - 1 off 8 in. x 1/2 x 1/8

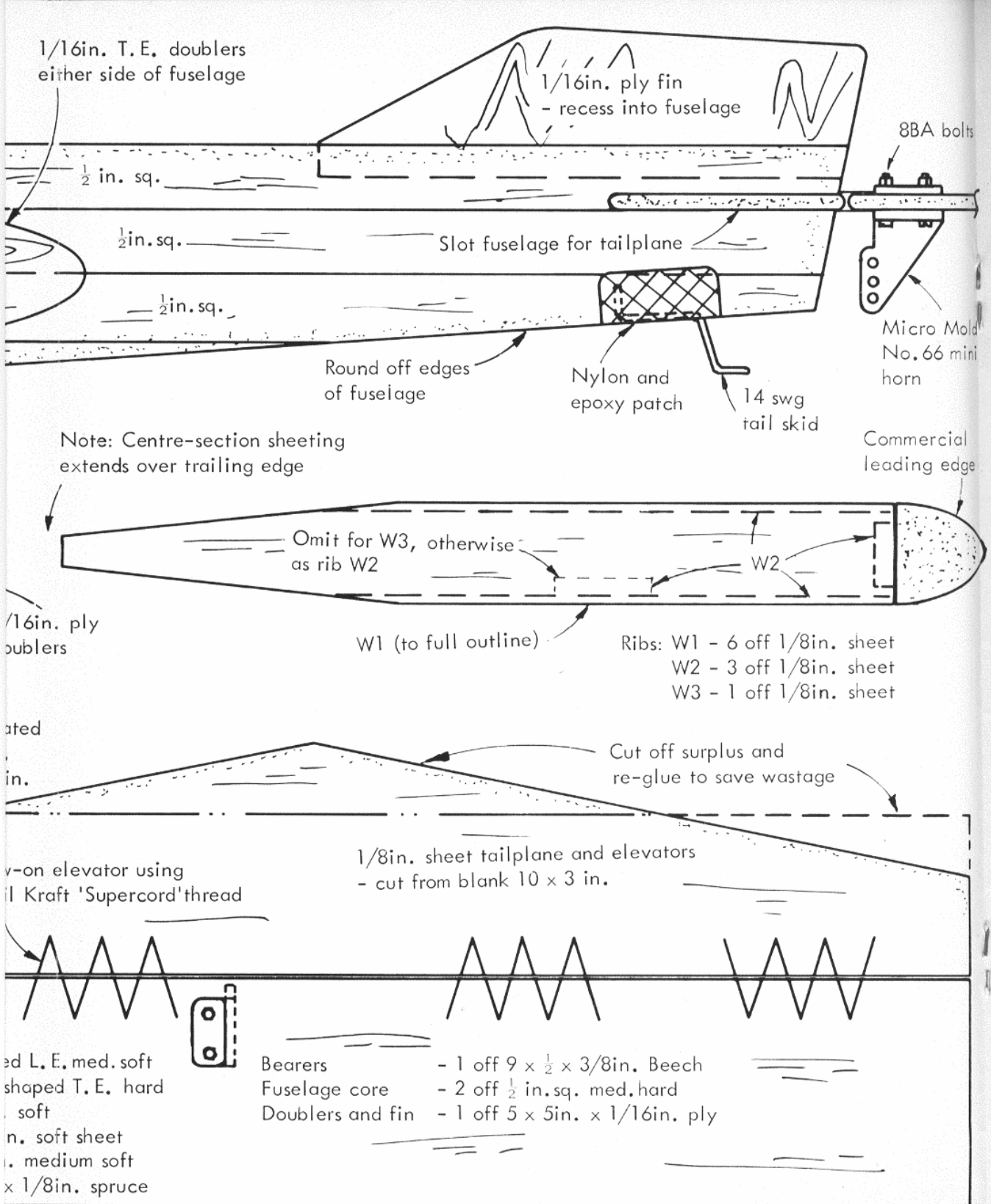

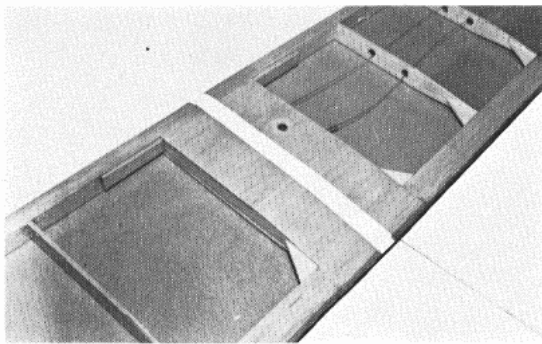

After covering the wing, cut a strip of film $\frac{3}{16}$ in. wide from the centre section where the fuselage will be fitted - this allows for a $\frac{1}{16}$ in. wide fillet of epoxy, and also ensures that fuel cannot seep under the film covering. The film is of course fuel proof, but run a fine brush loaded with fuel proofer along all exposed edges of film to prevent seepage at these points.

get the CG into the recommended range before the first flight. However, if you are an experienced pilot, or can call on the use of one for the first flight, make a test flight to see if ballasting is necessary for the chances are that it will not be required unless you have used a very light motor like a plain-bearing 2.5cc glow. The first *Mini Slow* flew 'off the board' with no adjustments required with an old Oliver Tiger up front (and a CG just $\frac{1}{16}$ in back from the wing leading edge - yes it flew fine, square reverse wing overs, square loops and all). Besides ballasting for the right CG and, of course, removing any warps (by use of the covering iron) that should not be there anyway, the only other trimming that should be necessary is adjusting the elevator throw. *Mini Slow* has quite a powerful elevator so as to give good manoeuvrability when combined with the forward CG positions recommended for stability purposes. About 30° each way elevator travel should give a pretty active model depending upon the CG position you actually have. Again, if you are not too experienced as a pilot, make the first flights with an elevator throw of less than 30° each way and then move the push-rod down a hole or two on the horn, once you are used to your *Mini Slow*, to get all of the manoeuvrability you want. Just about any 2.5cc motor should prove ideal in your *Mini Slow*, mine has an old MVVS 2.5 TRS diesel equipped with a Taipan 7 x 6in nylon prop and it goes a fair whack. Particularly

We soldered tinplate brackets onto the tank and then used self tapping screws to retain the tank to the fuselage. Any method can be used, but remember that diesel fuel rots rubber bands! Fox 19 provides really good performance - a sports 2.5cc engine would be quite adequate for beginners.

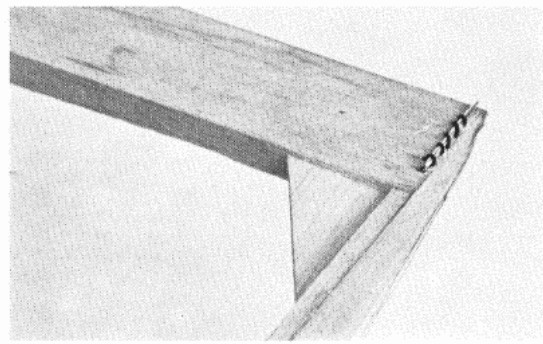
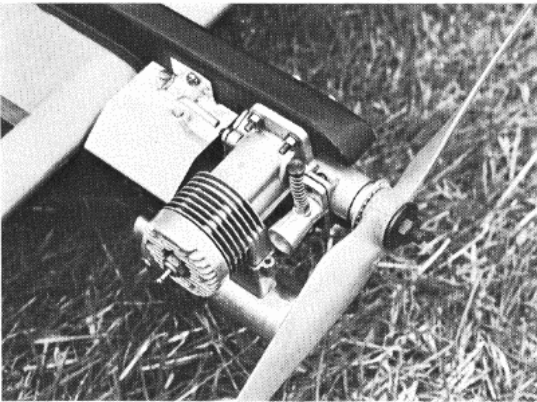

If flying over tarmac, add these single tip skids - they consist of paper clips bent around the trailing edge (ends dig into the balsa) stitched and epoxied in place. Incidentally, if using a diesel engine, spray the film covering with 'Pledge' or equivalent furniture polish before and after each flying session, as diesel fuel will otherwise tend to slacken off the film.

if you are using a silenced motor (and you do, don't you?) underpowering your *Mini Slow* or sending it off with a poor setting, can lead to trouble in wind for it carries quite a bit of wing area and should therefore be a lightly loaded wing - if the wind takes over control, watch out! With most current 2.5cc motors, including diesels, an 8 x 4 or 7 x 6in prop is a better choice than an 8 x 6in which may load up your motor too much. For general sports flying, an 8 x 4in nylon should give the best results. A 30cc commercial 'stunt' tank is shown for these are short enough to allow a reasonable model CG and yet give a motor run in excess of three minutes which is more than enough for most flights. Fly on light-weight 'Laystrate' or equivalent lines, the seemingly universal 52ft 3in handle to model centre-line length is very suitable for this model when using a 2.5cc motor as the power source.

Mini Slow is intended to be a fun model. So, as well as just solo sports flying, why not get your friends to build one too and try our North West solo all-in-one event for your club contest. Or use *Mini Slow's* in club one-design rat-race, stunt or even combat contests. How about a 3-in-1 event like the Feltham club does; stunt then racing then combat all on one day using the same model? *Mini Slow* is quite suitable for any of these, but whatever use you put your model to, fun is guaranteed and at very little cost in terms of building time and materials.

The elevator is large and powerful - so if you are inexperienced move the pushrod to the top hole of the elevator horn to reduce movement. As you gain experience, move the pushrod down and gain the advantage of increased performance. We used an R/C fitting to retain the pushrod - but a soldered washer or clip is fine.

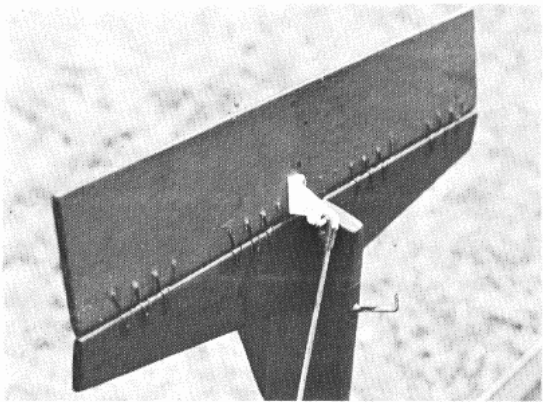

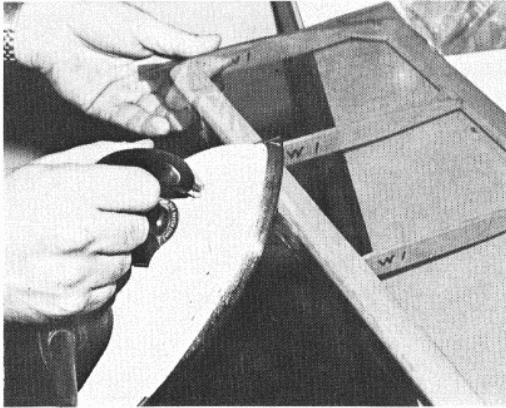

Lay the plastic film over the wing, then using a domestic iron, tack the film onto each tip, then work along the leading and trailing edges 'rolling' the film around these components with the iron as shown. Do not worry about shrinking the film taut at this stage, just concentrate on sticking the film to the wood without forming creases.

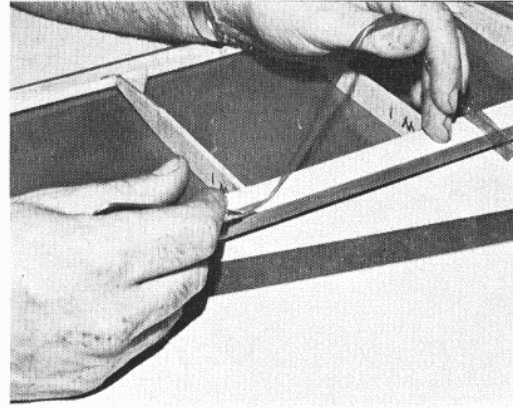

After the top surface has had the film tacked along the perimeter, and still before tautening the covering material, invert the wing and stick down sufficient film to give an overlap. Trim off the excess material with a straight edge and sharp blade. Remember, the film is transparent, and roughly cut edges show up badly!

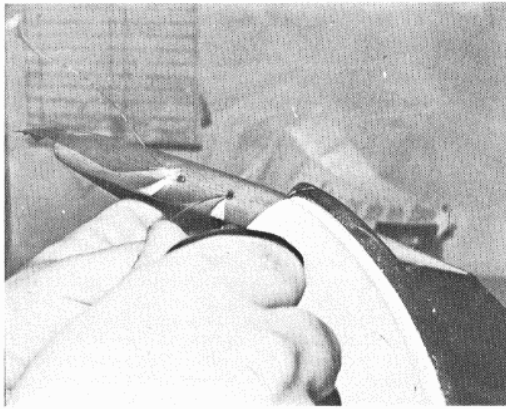

Now to bring the film over the tips - still before carrying out the main shrinking process. Note how the film has been cut to clear the leadouts. Pull on the film with one hand while working it around the curve with the iron. Film will stretch quite easily when warmed by the iron. Stick the film down just beyond the half way mark - the second piece of covering will then have a small overlap.

When the top surface has been covered, repeat exactly for the underside. Here the iron is being used to 'roll' the film down over the trailing edge. Run a sharp blade along the trailing edge to trim off excess. Note pushrod is left plenty long enough for later connection to elevator.

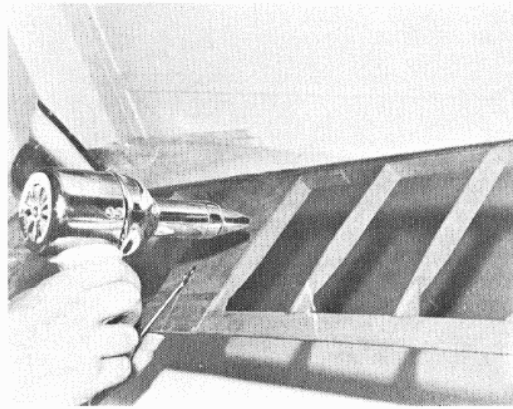
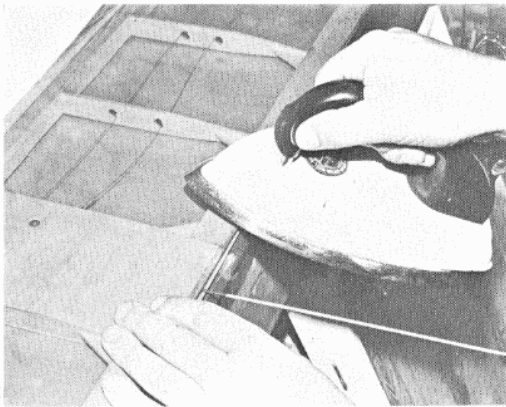

At last the shrinking process can begin - and before the underside covering is commenced. Photograph shows a hot air gun being used - a very useful device, available from all good model shops. Alternatively the iron can still be used, but hold just above the surface of the film. A slight increase in temperature may be required, but be careful of burning a hole through the film. It melts like magic . . .

If using a heat gun it is advisable to push the film into good contact with the balsa at the centre section by rubbing with a piece of cloth as the film is heated. This ensures a good bond. If using the iron, let it gently touch the film to get good contact, but watch the temperature.

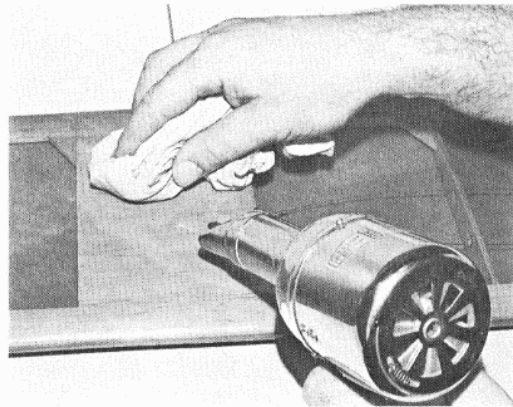

COMBAT DESIGN

BY MICK TIERNAN



Our author (in safety hat) officiates at a combat contest as Steve Bingham prepares to launch an old fashioned (i.e. pre-foam!) Titan design.

FOR MYSELF, combat flying took a turn for the worse when Pete Tribe of Northwood started to win rallies with a flying wing model called *Razor Blade*, destroying the chances of fine old designs like Mike Kendrick's *Black Ghost* and the Leicester team's *Super Looper* both of which had wings, fuselages, tailplanes and fins, the wing being rubber banded to the fuselage, replaceable

Most wings in those days were constructed along the same lines, i.e., a $\frac{3}{8}$ in or $\frac{1}{2}$ in square leading edge, $\frac{3}{8}$ in \times $\frac{1}{4}$ in spruce spars at the thickest part of the section and with the trailing edge cut from $\frac{1}{4}$ in thick sheet balsa - see Figure 1.

The next major step forward in construction was to dispense with the spars and to support the whole airframe from a strong, usually laminin-

centre sheeting and the use of pre-formed balsa leading edges to replace laminated ones.

However, a good deal of experiment took place with model shape (tapered or elliptical wings) and model size, when Dave Wiseman with his *Sho-gun* and later Dave Wood with his *Titan* proved what should have been obvious, that a 350 square inch model will turn tighter than a 250 square inch model, and therefore go round the loops quicker. This leads to the second cardinal rule of model design - plenty of area.

Generally, the faster the model, the more area can be used. An Oliver Tiger diesel would look silly trying to tow a 440 square inch, $1\frac{1}{2}$ in thick section model round, while a Super Tigre or Rossi glow in a 300 square inch model will not turn within a 20ft diameter circle. Look at some of the American models - our wing-

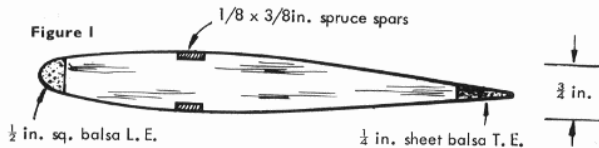

in the event of breakage. As these were the days of one model per bout (or 'match' as the Americans insist on calling it), wing replacements were the order of the day, as were fuselage, motor, propeller and just about anything you could think of, as long as something remained of the original model!

ated, leading edge (for example, Mike Davis's *Dominator*, Richard Wilkens' *Early Bird*), which leads nicely into the first rule of combat design; keep it simple, the less parts in the model, the less there are to break. After *Dominator*, no major constructional techniques were evolved until the foam model, except for leaving out

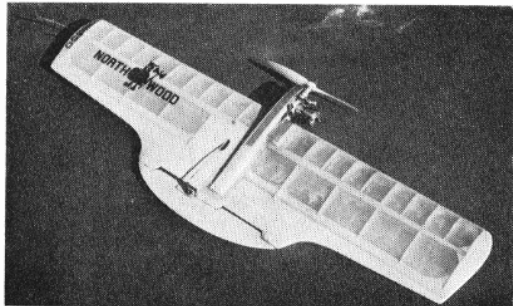

Pete Tribe developed his original *Razor Blade* until it looked like this (left) but still the basic layout remained, with $\frac{3}{8}$ in thick section, $\frac{1}{4}$ in sheet trailing edge and spruce spars. Mike Davis (right) simplified combat models with his *Dominator* - no spars, hefty leading edge and almost unbreakable when nylon covered.



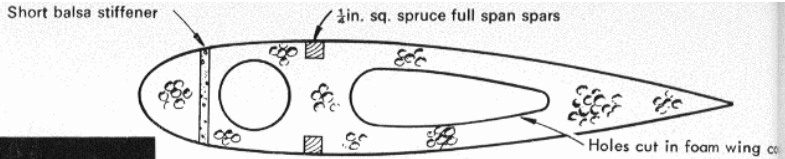
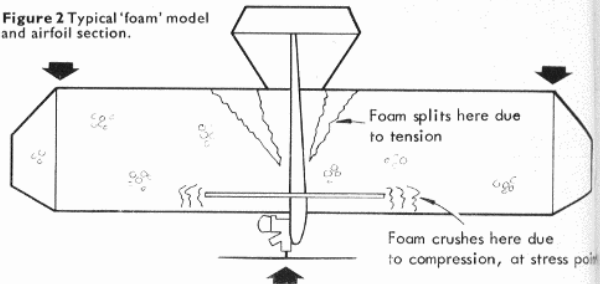

Figure 2 Typical 'foam' model and airfoil section.



Ian Hutchinson displays a Sho-gun, built from a kit by Deco Models. This Dave Wiseman design shows how wing areas have increased - although the plan form still resembles the Razor Blade.

overs are tighter than their loops! To turn a model from level flight in one direction to level flight in the opposite direction, the momentum of the model must be overcome by the lifting forces acting on the wing. Momentum equals half mass (or weight) multiplied by the square of the velocity, so if the speed of a model is increased from 70mph to 90mph (28 per cent approximately) the increase in momentum is roughly 64 per cent.

Constructional techniques on the now almost universally employed expanded polystyrene 'foam' models now seem to have taken a backward step, most people use two spruce spars to stiffen the wing against aerodynamic forces, with a strengthening piece at, or near, the leading edge, similar in effect to the old *Razor Blade* construction (Figure 2). On impact with the ground, the relatively heavy tips on a straight wing model tend to move forwards, breaking the foam at the rear of the centre section and crushing the foam where the strengthening pieces at the leading

edge stop. This is another inescapable fact of model design. Models always break where the strengthening pieces stop, so either leave them out or continue them all the way through.

From this it follows that our design criteria are now:

- (1) As few parts as possible
- (2) Correct wing area for motor used
- (3) Wing tips as light as possible
- (4) A strong leading edge: as strong as possible at the centre section and as light as possible at the tips.

To design a combat model following these rules, we must first make certain arbitrary decisions, i.e.:

Wing Section (thickness) - usually 15 per cent

Wing Area (For ST G20-15) - say 420 sq in

Wing Span - for convenience say 36in plus two 3in tips giving a total of 42in span.

A wing 42in x 10in will give the correct wing area, but as we require light tips and a strong centre section, add 2in to the root chord and take

2in from the tip chord. For a 15 per cent thick wing, make the root section 1 1/4 in thick, tips 1 1/4 in thick.

This is about the maximum practical taper that can be used: any larger root chord moves the centre of gravity too far back. This would mean the motor must be moved forwards, weakening the motor mount and producing a 'long' model which is not as quick to react to the controls as a shorter one. Another answer is to sweep back the leading edge. This is worth experimenting with, although it means a join in the leading edge at the position of maximum stress (the centre). A strong join can be made using glass fibre tape and epoxy, standard R/C practice on foam wings. From experience, an 8in tip chord seems to be the minimum practicable, perhaps an aerodynamicist could explain why! It could be something to do with scale effect.

We now require something to support the motor controls and tailplane. I have not yet found a method of dispensing with any of these, but I am working on it . . .

To support the controls, a 1/4 in medium balsa centre rib (see Figure 4) with a cut out 2 1/2 in long and 1/4 in wide for the bellcrank, with 1/2 in ply, 1 in wide x 12 1/2 in long, top and bottom produces a simple and strong construction. A 10swg nail with two pieces of rubber fuel tubing as spacers is much stronger and quicker to make than the usual 6 BA bolt and ply plate bellcrank mount; the pivot is supported at both ends by the 1/2 in ply. See Figure 5.

There is no necessity for bellcrank stops if control linkages are designed properly, i.e., a maximum of 1/8 in from the bellcrank pivot to the pushrod hole.

American FAI combat designs, as typified by this 'Firefly', are still low on area, hence poor turning radius and speed through manoeuvres.

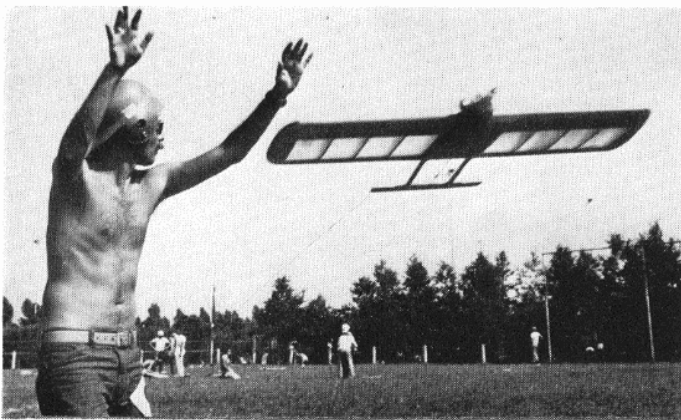

Motor mounts are traditionally made from $\frac{1}{4}$ in balsa and $\frac{1}{8}$ in ply with hardwood bearers (five pieces of wood in all) carved, sanded, covered and fuelproofed – a long and complicated job. I make mine from one piece of $\frac{1}{2}$ in thick hard industrial nylon, bandsawed to the shape shown in *Figure 6*. The nylon is expensive, but once you have made one (or ten) they can be removed from broken models and re-used over and over again. The material does not absorb fuel, so just epoxy in place and then forget it.

We now come to the most important constructional detail, the leading edge. This is made from one piece of $\frac{1}{4}$ in ply as shown in *Figure 7*, wrapped round the leading edge of the foam after coating both (joining) surfaces with Copydex impact adhesive. If the outside of the ply is wet, it will roll round and stick down without cracking. A much stronger and slightly heavier method is to use $\frac{1}{2}$ in ply, but this must be soaked in hot water, wrapped round a former, tied in place with string and allowed

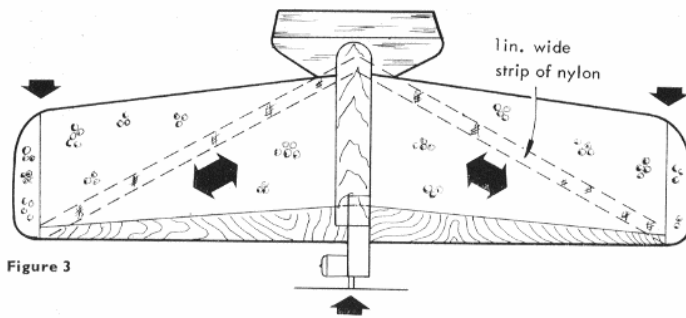

Figure 3

to dry. An old balsa leading edge works well as a former, it does not have to be exactly the right shape. If a really light model is required, obechi veneer can be used, but this will not stand ground impact.

Nylon strips glued in place as shown in *Figure 3* (using white glue thinned with water) will take the tension forces trying to split the foam on ground impact. The strong leading edge is supported at the tips

in the same manner as a suspension bridge, while the thick root and thin tips give a cantilever effect. Another advantage is that this leading edge cannot be cut by streamer strings.

I may have given the impression in the earlier paragraphs that using these techniques, one can build a model which can hit the ground with impunity, as in the old days of nylon covered, Oliver powered *Warlords* and *Andurils*. This is untrue. It is (continued on page 48)

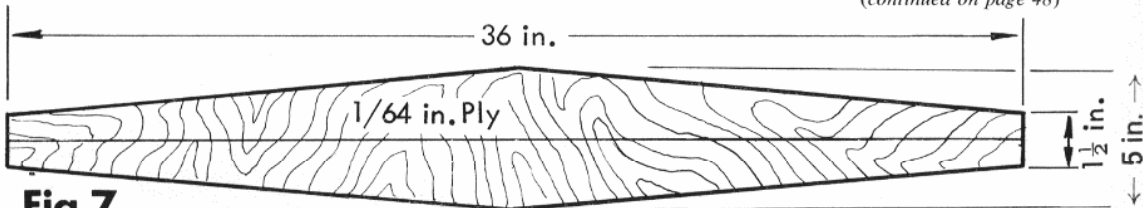

Fig 7

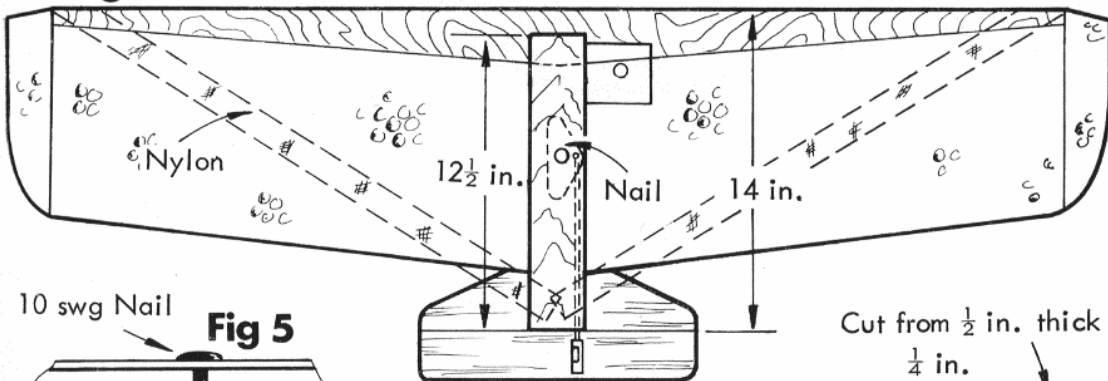
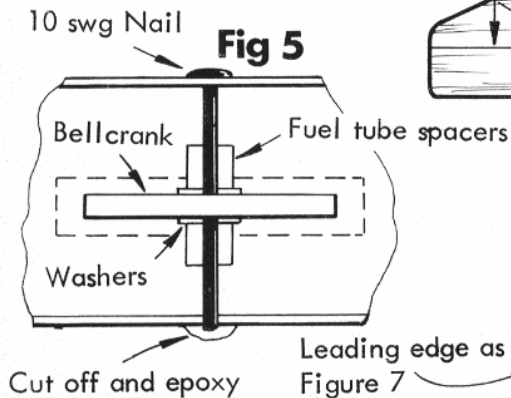

Fig 5



1/4 in. sheet centre rib

Fig 4

Bellcrank as Figure 5

Cut from $\frac{1}{2}$ in. thick nylon

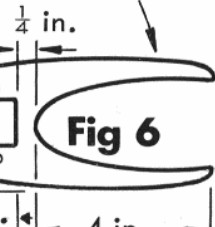

Fig 6

FUEL TANKS FOR STUNTERS

BY GLEN ALISON

THERE HAVE been many fuel tank designs for aerobatic models over the years, some good, some bad. This feature is intended to identify the different types of tanks that have evolved up to the present state of the art, and to show the advantages, or disadvantages, applicable to each.

The basic wedge tank (Figure 1) was the first attempt at producing a tank that would permit inverted flying: the

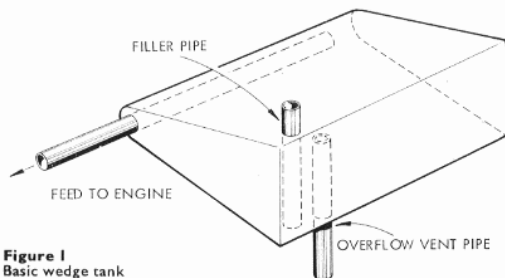

Figure 1
Basic wedge tank

filler and vent pipe system prevented fuel from running out when upside down. It was made wedge shaped in order to allow every last drop of fuel to be used, but the disadvantages were that because of the wedge shape it was awkward to install in the model, and contained a low volume of fuel for the space it consumed. Also, with the vent and filler pipes arranged vertically, syphoning of the fuel took place, due to the airflow from the propeller causing a venturi vacuum effect on the pipes, and therefore sucking the fuel out.

This simple idea was improved upon by making the tank more rectangular in overall shape, but still maintaining a wedge at the side of the tank. This overcame the installation and volume problems, while syphoning was cured by bending the filler and vent pipes forward into the

airstream, thus creating a slight positive pressure. (See Figure 2).

By this time, models were getting more sophisticated and fliers more discerning as to the motor runs they were getting from their tanks. One of the undesirable effects of this tank design is that as the fuel is used up during a flight, then the hydraulic head, due to a combination of gravity and centrifugal force, is gradually reduced and the effect is for the motor to 'lean out' or get faster as the flight progressed. One then had the dilemma of how to set the motor on the ground; either the needle would be set too rich for the beginning, or too lean for the end of the flight.

Now, have you ever seen one of those water containers in chicken houses, where there is a large bottle of water with a little drinking trough at the bottom? This is called a Marriot bottle, and the reason why the water does not all run out is because a partial vacuum is formed in the air space at the top. As the chicken drinks some water the level in its little trough goes down until a bubble of air is

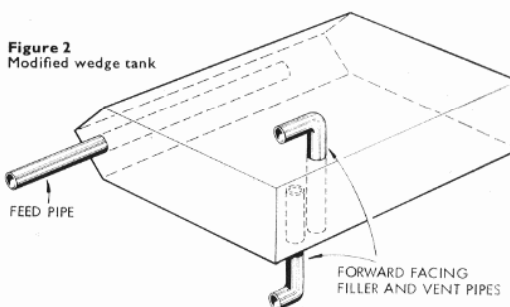

Figure 2
Modified wedge tank



Our author Glen Alison, a regular contributor to AeroModeller, readies his model for a competition flight. Whether you fly competition or sports models, the same conditions exist; you will need a good, consistent engine run in order to concentrate upon, and enjoy, your flying.

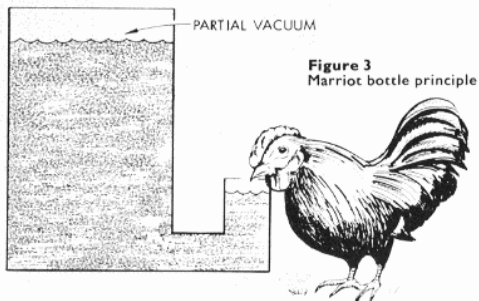

Figure 3
Marriot bottle principle

admitted into the main chamber, thus allowing the little trough to be replenished (Figure 3).

Somebody clever, I do not know who, realised the principle could be applied to stunt tanks and these are known as 'Chicken Hopper' or 'Uniflow' (Figure 4) types. Uniflow is the simplest, and a glance at Figure 5 will show the principle upon which it operates.

The effect is to eliminate the leaning out effect. So now we have a tank which works inverted, does not lose fuel in flight, takes up the minimum of space in relation to fuel held, and gives a constant motor run. What else could be wrong? We now have to consider the requirements of the FAI aerobatic schedule and rules. The problem that some fliers found was that when attempting the last manoeuvre in the schedule – the four leaf clover – they would experience fuel feed trouble on the first loop as the fuel level in the tank by this time is very low and the manoeuvre is entered at high level where centrifugal force on the fuel is minimised and it tended to run away from the feed pipe, as shown in Figure 6. However, if the four leaf clover was completed successfully, then one would find that there was too much fuel left in the tank to stop within the regulation seven minutes! This leads to ungainly gyrations flying high in the circle in order to try to cut the engine for landing.

So what was the answer? Simply to let the feed pipe go where the fuel is, i.e. make it flexible with a weight on the end, hence the 'clunk' tank. Long established in radio controlled aerobatic models, this form of tank is a recent

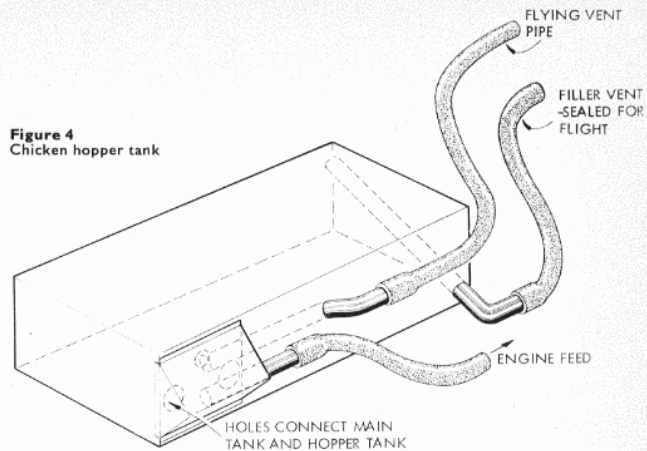

Figure 4
Chicken hopper tank

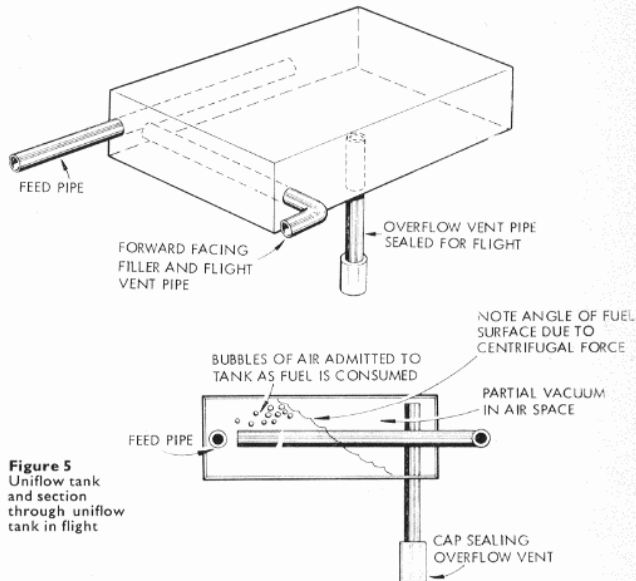
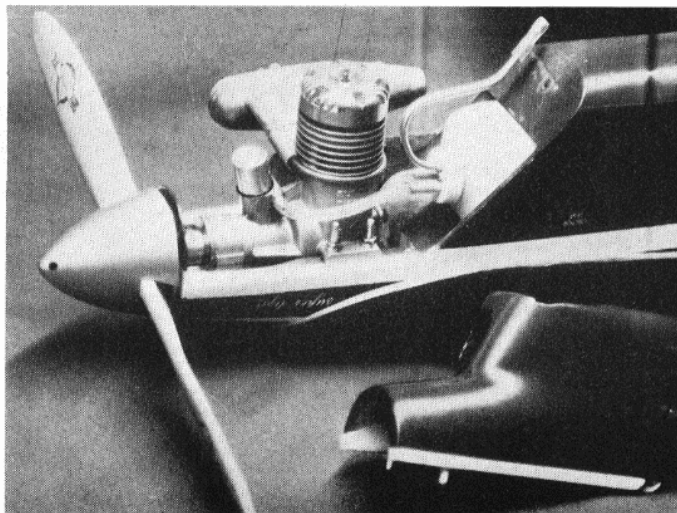

Figure 5
Uniflow tank and section through uniflow tank in flight



The advantages of an accessible fuel tank cannot be overstressed. On Ted Fowler's model, the polythene clunk tank may be removed by taking out the engine and then sliding it out through the front former. The Super Tigre 46 engine has been fitted with an extension shaft to give a neater cowling line.

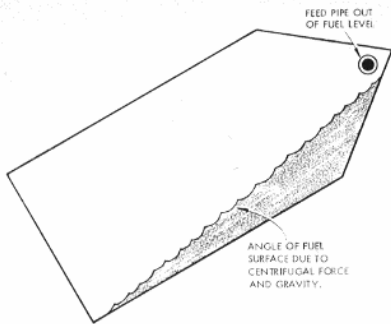

Figure 6: Engine starved of fuel (view from rear)

innovation for control line. Clunk tanks are usually made from small round or rectangular polythene bottles, although the traditional tinplate construction is still applicable. The advantages of the polythene bottle are that no soldering is required, the contents are visible, and if all the plumbing is fitted to the cap then it is an easy job to unscrew it to make modifications, or renew pipes etc.

The rectangular tanks are best because of the ease of installation and minimised wasted space. Round tanks can rotate with the engine vibration and twist the fuel tubing, thus restricting fuel flow.

The clunk tank, as drawn in Figure 7, therefore solves our fuel feed problems, but it is not 'uniflow' and we have the old problem of leaning out during the run. The cure? – combine both systems together, into the 'Double Clunk Uniflow' tank!

This system, illustrated in Figure 8, has proved to be very reliable, provided that the tubing is securely bound onto the fittings. The two weights on the fuel feed and air

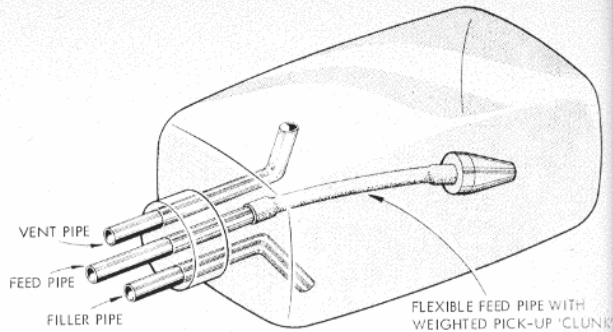

Figure 7: Clunk tank

vent lines are free to move as the fuel does and therefore follows the fuel wherever it goes in the tank. The engine run is steady until the last five laps or so when the vent becomes uncovered by fuel – this has the effect of speeding up the engine, thus giving sufficient warning to the pilot that his flight is nearly over!

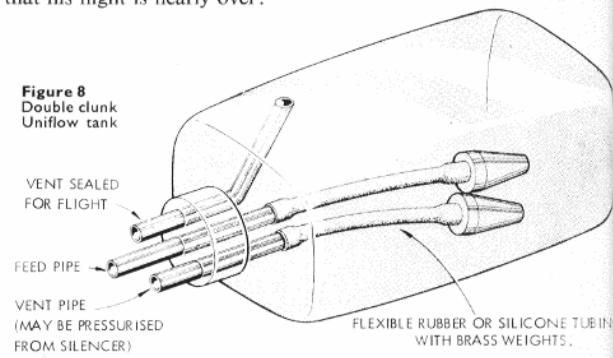

Figure 8
Double clunk
Uniflow tank

COMBAT DESIGN *continued from page 45*

momentum which breaks models. Using today's constructional methods, it would be possible to build an Oliver powered model of around 300 sq in and 16oz weight, which would be indestructible (except for mid air collisions), but an unbreakable 420 sq in glow powered model has still to be built.

It is only by thinking carefully about why a certain model has broken in a certain place, and by continuous development, that a model can be produced which is stronger for a given weight. When a correctly designed model does break, everything should break at the same time, proving that you have efficient construction, carrying no excess weight.

In the future, a moulded combat pan is a distinct possibility, which will fulfil the function of motor mount, centre rib, bellcrank support and tail support, with a moulded plastic pacifier pod attached. To build the model of the future, just make up two wing halves and a tailplane, fix the controls in place, epoxy the wings and tail in position and cover. The slowest builder could produce a

model in an hour. Expense should be no problem – there is only about ten pence worth of plastic in the whole thing! When the difficult problem of joining the wing halves together inside the pan (without producing stress points and without reverting to the simple answer of using spruce spars) is solved, I expect to see combat pans on sale; the instant

model will have come one step nearer.

While I am daydreaming about instant models, how about wings moulded in rigid polyurethane, a material which can be blown up like expanded polystyrene, but which forms a smooth skin on the outside? Just glue them into the combat pan, stick on a tail, fuel proof and fly! Perhaps someone could then find an alternative to the usual ¼ in balsa tailplane. That item has been with us for twenty years and will probably be around for another twenty . . .

A Dutch built example of the Super Star II – a classic model in that it has dominated contests all over the world since its appearance in 1976. Not the first all-foam design flown in the UK but certainly the most successful yet, and sole inspiration of the current crop.



FLY THE SCHEDULE

BY JIM MANNALL



When this feature was first published in the July and August 1973 Aero-Modeller issues, it rapidly became a classic. The author Jim Mannall (right - with his famous Nimrod design) has been amongst the top few aerobatic fliers in this country for more years than he probably cares to remember, and his treatise on how to fly the aerobatic schedule has been much sought after reading by budding pilots. We thus make no apologies for re-printing it on these following pages!

MANY ARTICLES have been written teaching the novice the elements of aerobatics, but this exposition is intended to carry on where most leave off and thus assumes that the reader is already a reasonably competent flier. What further steps are then necessary to enable him (or her) to enter the competition field?

Beginners often ask 'How do you learn to fly the FAI stunt schedule?' There is no simple answer except to say 'Study the manoeuvre diagrams in the rule book, then go out and practice,' but this presupposes that the flier has a suitable model and can fly it with safety. Before being concerned with the schedule, and before building a competition model, it is important to be able to fly inverted with confidence. Understandably, if in trouble the usual 'panic reaction' is to attempt recovery into normal flight but in many cases this is impossible and an inverted recovery, or even landing, is necessary and always preferable to an *unsuccessful* attempt to get the model upright again!

If my own early thoughts were anything to go by, it is a commonly held belief that a competition stunt model is difficult to fly compared with, say, a combat model. Not so! Obviously, there are great differences, but in level flight both are equally easy to fly. To describe a stunter as sensitive to the controls is misleading; the word responsive is a better description. Manoeuvrability available is tremendous, but it is not achieved by sacrificing stability, as is the case with many smaller models. Newcomers to stunt can run into trouble through lack of appreciation of the models' limitations, particularly in square manoeuvres, where they snap on full elevator with the result that the model virtually stops during the turn and cannot climb vertically with enough speed to provide adequate line tension. This situation worsens with each corner resulting in a battle to retain control, the intended manoeuvre being forgotten! The first thing to remember then, is not to try for very tight, square, corners at first. Keep all your manoeuvres fairly large, and above all smooth - no jerky wrist movements.

Choice of model depends largely on the builder's previous experience, but for a first stunter choose the simpler designs; a

complicated structure tends to be heavier. Avoid wing-mounted undercarriages as they do not stand up well to the inevitable hard landings and keep the finish light. That super paint job may look good but it can be very heavy - save it for the second model when you have a better idea how much weight can be 'spared'.

Once you have the model flying and feel reasonably confident, take a careful look at the trim. There are two points which require attention for optimum performance and ability to hold line tension. First does the model tend to roll in towards you in upright or inverted flight? This shows up best during high flying when line tension is low. Corrections should be made by twisting the flaps in the opposite direction until any rolling tendency is removed. The other probable fault is that the model may tend to climb or dive in level flight, often accompanied by a tendency to fly tighter inside than outside loops or vice versa. If the model climbs, bend the flaps down relative to the elevators until a 'straight' trim is achieved. Finally, try a wingover as slow as possible. With little or no line tension when overhead any tendency to roll or veer off is revealed.

Learning the stunt schedule is now largely a question of practice, plus of course determination, concentration, attention to detail and a willingness to learn from others. Above all, do not be disheartened if you do not do very well at first - it is no exaggeration to say that your first competition does more for your standard of flying than weeks of practice.

Careful preparation is essential to give the model the consistency and mechanical reliability necessary if one is to be free to concentrate on flying. The day before a competition give the model a thorough inspection, checking such items as engine mounting bolts, cylinder head bolts, silencer fixing, tank fixing and glowplug condition. Make sure that the fuel system is free from leaks and blockages. A fuel line filter prevents the jet from becoming blocked, but remember that in time it too will become congested.

Arrive with plenty of time for a practice test flight to establish the motor setting, then relax. Always be ready to fly when called -

remember that the previous flier may call an attempt. The starting procedure should become routine with everything carried out in a well rehearsed sequence; do not leave too much to do at the flight line. Have the model fueled up before you enter the circle and check items such as prop nut tightness, wing bolt security, etc. My own procedure is as follows:

Before entering the circle (while preceding competitor is performing) reel out the lines and check all connections and the handle adjustment. Check wing bolts and cowl for tightness. Check propeller nut. Remove vent plug, fill tank and replace plug. When called upon to fly, enter the circle promptly, check wind direction and position of the judges, and place the model at the selected starting point (more on this later). Position the accumulator/toolbox behind the model in a convenient place for when the model is inverted for starting. Check that the judges and timekeeper are ready. Remove the tank vent plug and top up the fuel to ensure the tank and engine feed pipe are full (the pipe tends to drain if the model is left standing). Invert the model and with your assistant holding it, prime the motor. Flick the propeller several times until the motor is freed up and feels 'right', then connect the accumulator and check the circuit. I use a testing circuit which includes a 2.5 volt torch bulb, but an ammeter may be used instead. A bulb limits the current through the circuit and a switch is used to short circuit the bulb for starting. Switch on and turn the engine over holding the propeller, feeling for a 'kick' as the piston passes the top of its stroke. Now signal to the judge/timekeeper that you are going to start and make sure that the signal is received - flick the propeller, and the engine should start.

With the model ready for take-off, check the connections at the leadouts before *walking* to the centre. Check the handle connections and try the control movement before signalling for takeoff; your assistant should not release the model until your hand falls after the signal.

Hand signals should be given clearly and with confidence. Raise the hand above the head for one lap before each manoeuvre. This may seem excessive but bear in mind

that between manoeuvres the judges must record the scores. Remember two laps are required between manoeuvres so the model must pass where they are performed (downwind) once before starting the next item. Start the signal three-quarters of a lap after the previous manoeuvre, and finish it after a further lap, leaving a quarter of a lap before the start of the next item. Note that the hand is raised when the model passes the downwind point for the first time, ensuring that the required two-lap interval is maintained.

Choose the starting position with care, especially in windy weather. The accepted position is with the model facing downwind, but this can produce problems with wing mounted two-wheel undercarriages, as the wheels are often further back, causing the model to tip forward in a strong tail-wind. I prefer to place the model upwind of the circle as from this position the model does not encounter a strong tail-wind until its groundspeed is sufficient for the controls to be effective. In addition, weathercock effect on the fin helps to keep the nose pointed outwards on take-off.

Let us now go through the schedule with a detailed look at each manoeuvre. It will be assumed that the model flies anti-clockwise and references to the left and right-hand sides of a manoeuvre correspond to the view seen by the pilot.

First the *take-off*. With most models a sufficiently long take-off run is obtained by letting the model fly itself off with the controls at neutral. If a tricycle or two-wheel

TAKE OFF

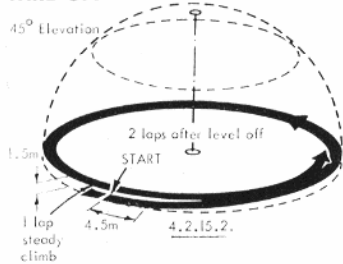

wing mounted undercarriage is used, the model may be held on the ground for a longer run, but remember that a smooth lift-off becomes more difficult as the speed increases. Adopting a crouching position with the handle near the ground prevents the inboard wheel lifting too soon. A common fault is too steep a climb; the model should not reach the normal flight level (five feet) until it is over the starting position. The first two laps of level flight also form part of the take-off manoeuvre. Signal during two further laps before starting the *reverse wingover*.

This manoeuvre should be positioned in line with the wind, starting at the upwind side of the circle. The judges should be directly upwind, so use them as a reference to ensure both halves of the manoeuvre are on the same line. Which way should the flier turn as the model passes overhead? Being left handed, I use the following technique: Stop turning just before the start of the reverse wingover and then as the model passes overhead turn *back* (clockwise), continuing to turn with the model during the inverted half lap. Stop just before the entry to the second half of the manoeuvre and as the model passes overhead for the second

REVERSE WINGOVER

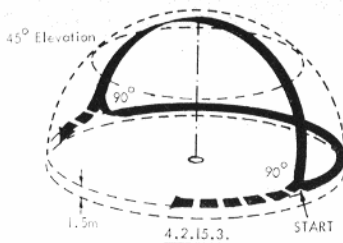

time start turning anti-clockwise again, continuing as it recovers into level flight. If you are right handed continue turning forward during the first half of the manoeuvre stopping as the model recovers into inverted flight. Turn back (clockwise) during the inverted half lap, stopping just before the entry to the second half of the wingover. Then as the model passes overhead for the second time turn forwards (anti-clockwise) again continuing as it recovers back into level flight.

In strong winds it is far easier to start a wingover just before the upwind point is reached, but then the second half is very difficult, if not impossible, to complete. Try to start the first half just *past* the upwind point, then the second half which is entered from inverted flight with the model generally flying slower, will be much easier. The rule book does not define the exit corner radii and it is therefore not necessary to make them very tight. Make them reasonably small, but keep the model's speed up and exit on a smooth recovery at the correct height, especially on the inverted half lap. A common fault is to pull-out too sharp, allowing the model to 'overshoot' the corner and zoom up. A sharp pull-out kills speed which cannot be regained in half a lap, making the second half of the wingover rather difficult! The wingover demands more confidence in the motor than any other manoeuvre, since should it stop or falter during the first few feet of the vertical climb, line tension is lost and recovery is very difficult.

The *three inside loops* which follow are one of the simplest manoeuvres in the schedule, although it is very difficult to score high points for them. An inside loop is generally the first manoeuvre that a beginner learns, and in consequence any errors are established early. To achieve consistently

THREE INSIDE LOOPS

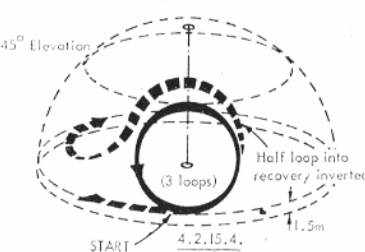

round loops of the correct size requires serious practice with a helper giving a second opinion on accuracy. They should be round with a line angle of 45 degrees at the top, while the second and third loops should be placed exactly over the first. Some models tend to 'walk round the circle' during consecutive loops, or the size of the loops may change as speeds build up, particularly in wind. After the last loop make an additional half-loop into *inverted flight*.

Remember to give a hand signal during

the first two inverted laps. The two judged laps should be smooth and level – beware the tendency for the model to drop when travelling downwind. Keep the height at five feet. Count the inverted laps carefully, make sure you have completed two laps after the

INVERTED FLIGHT

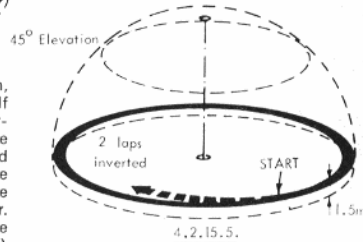

hand signal before signalling again (two more laps) for the *outside loops*.

These should be identical in size to the inside loops, again followed by an extra half loop to recover into normal level flight. Some models speed up so much when performing

THREE OUTSIDE LOOPS

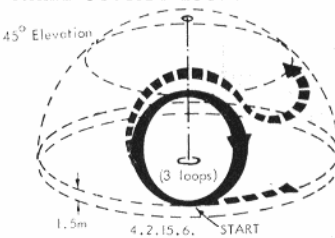

loops in windy weather that the third loop is a trial of strength. This can be eased by looping with the model travelling into the wind at the bottom, i.e., go past the downwind point before starting them, but this does make it difficult to maintain a smooth shape, and there is a tendency to put a 'flat' on the bottom of each loop.

So much has been said about the difficulties of square manoeuvres that the newcomer may be forgiven for thinking that tight corners are all important. Not so: the most common error is to make the corners too tight, forgetting that the model must fly smoothly in 'straight' lines between the corner and to do this flying speed must be maintained. Concentrate on the shape of the figure; get the four sides in the right places and keep it large. With practice, the corners will tighten but they must be smooth. Most important, the model should leave the corner without wobbling or jerking, and should be heading in the right direction with sufficient speed to reach the next corner under control. The actual shape of a square loop is difficult to define. Since the model flies on the surface of a hemisphere, lines which appear straight to the flier are not truly straight and will not appear straight to the judges. A compromise must be made. The two obvious alternatives are:

a) A figure in which the four angles are all right angles. This gives a short top leg only 70 per cent of the base length and is not a good solution.

b) A figure with all sides and all angles equal. I believe the latter to be the best solution, being very close to a true square. Indeed it is found by taking a true square of the appropriate size and placing its four corners

on the surface of the hemisphere on which the model flies. It is then possible for the model to fly along four 'straight' lines (as seen by the flier) between the four corners. Unfortunately although this gives four equal sides (actually equal areas of four great circles) and also equal angles they are not right angles, but slightly obtuse. The actual angle depends on your viewpoint, only the flier sees four equal angles and they are almost 100 degrees. (99 deg. 54 min for the purists!)

The rulebook definition is very close to the figure just described, the difference being that the top leg is defined as inverted level flight at a constant elevation of 45 degrees. The flight path between the top corners is thus not a great circle, and should appear curved to the flier. The two top angles are 75 degrees 26 mins. (I know that seems far too acute, but that is how the geometry works out) and the base angles are 99 degrees 54 mins. Note that in the ideal figure the elevation is only 45 degrees at the top corners, it increases along the top leg to reach a maximum of 49 degrees 54 mins at the centre of the figure.

Having determined on paper what shape a 'square' should be, how does one put theory into practice?

Remember that the shape must appear correct to the judges, so you will need a helper watching outside the circle to point out any errors. Plan the whole manoeuvre in advance so that you know where the corners should be. The length of the base gives an included angle at the centre of 45 degrees, its mid-point being directly downwind. Stand facing this point. For the first corner, turn the model into a vertical climb, not too tight, and climb to an elevation of 45 degrees. But wait, the top leg must equal the length of the base. Its position should be fixed in your mind and the model should be headed towards its left hand end. So the first corner should have been greater than 90 degrees, making the model climb toward

TWO SQUARE LOOPS

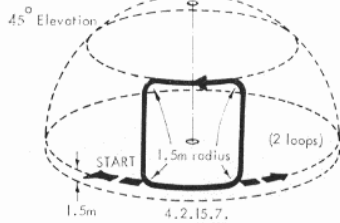

a point to your left rather than vertically overhead. Start again, making the first corner 100 degrees and when the second corner is reached notice how the model is pointed not vertically but outwards relative to the centre of the square. Gravity and wind help us round the second corner, too much if anything, so keep the included angle large, much greater than the 75 degrees that is theoretically required. You can afford to let the model climb slightly over the first half of the inverted top leg. The third corner is the tight one, let the model come round until it is pointed inwards, symmetrical with the top of the vertical climb. If you do all this right, the last corner should be greater than 90 degrees symmetrical with the first one. Many people leave themselves too much to do in the last corner, the secret lies in that tight third corner, put more into that and the last

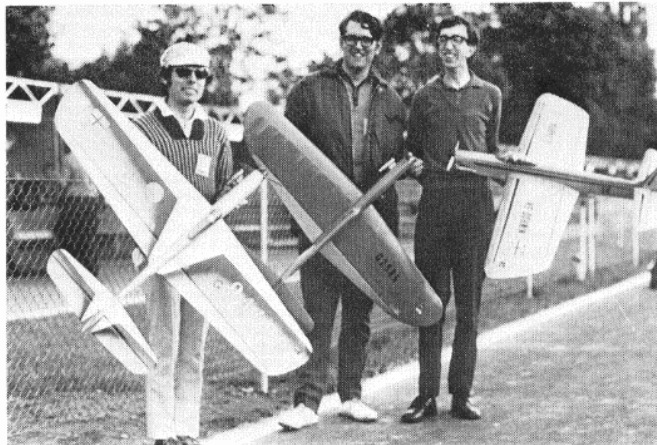

Jim (far right) has flown for Britain on many occasions, in fact he is a 'regular' team member. Here he is seen with John Newnham (left) and Steve Blake at Pecs in Hungary for the 1972 World Championships.

corner is much easier. Now the second square loop begins. Is the model still going fast enough? Be particularly careful not to 'overdo' the second corner of this figure or the model will lose height along the top leg and the last two corners will be lost in the rush to get back to normal level flight before the ground swallows up the model!

The square *outside loops* are similar to the inside ones, but start with the model at an elevation of 45 degrees. Begin the climb from level flight, three-quarters of a lap after the end of the inside square loops (as your hand signal begins) taking a further lap to reach the 45 degree elevation. The first corner is equivalent to the third corner of an inside loop and should be tight, the model turning through more than 90 degrees. The difficulty now is to remember where the ground is so as to accurately place the second corner - I find it helps to glance back at the horizon just before the first corner. No such problem exists in the second loop as the base line has already been established. Remember that the second loop finished with the model in level flight at 45 degrees elevation. As in the inside loops, the corner at the top of the climb should be 'loose' letting the model climb slightly as it leaves the corner. The rule book calls for recovery within a quarter lap so at the point where the manoeuvre started do an extra 'half' corner putting the model into a 45 degrees dive recovering smoothly into level flight at five feet.

The shape of the *triangular loops* can be found by placing the three corners of an equivalent triangle on the hemisphere on

TWO OUTSIDE SQUARE LOOPS

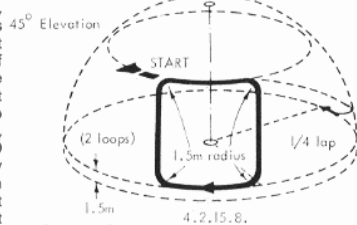

which the model flies - three sides of the figure are then formed by equal areas of three great circles. The true angle (again seen only by the fliers) at each corner is 67 degrees. The angle at the centre of the circle between the two bottom corners is 50 degrees 10 mins. Position the manoeuvre so that the top corner is directly downwind. Do not make the first corner too acute, remember it should be 67 degrees

TWO TRIANGULAR LOOPS

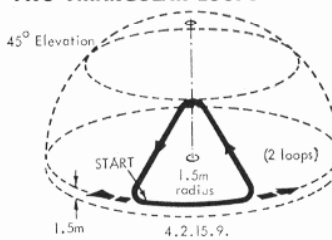

not 60 degrees. It is remarkable how many people make the top corner too wide. Keep the second corner equal to the first and the last corner should then be correct. As in the square loops, if the last but one corner is right, the last corner is less difficult, although it is undoubtedly more difficult than the last corner of a square loop. I can only repeat the advice given earlier, keep the corners large at first. It is pointless doing a really sharp corner if the recovery is not smooth and at the correct height.

The manoeuvres so far completed comprise the basic shapes used in aerobatics.

The manoeuvres that make up the rest of the stunt schedule continue to make use of the basic round, square and triangular shapes but they become more complicated, making it increasingly difficult to maintain your concentration. Particularly beware of the temptation to rush through the final manoeuvres in the fear that the motor may cut early - remember this as the schedule continues with the *horizontal eights*.

These should be positioned with the intersection between inside and outside loops directly downwind, thus the first

inside loop must be started with the model still travelling downwind. There is a temptation to start this first loop too late so that the intersection is not downwind and in turn the outside loops are displaced round the circle away from the downwind point. At best the result is a badly distorted shape due to the wind blowing across the figure, or at worst line tension may be lost completely at the top of the outside loops. Even with the intersection correctly placed the wind has the effect of 'pushing in' each side of the manoeuvre so that the inside and outside loops overlap in the centre. This is

TWO HORIZONTAL EIGHTS

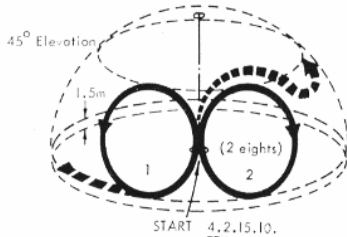

very easily seen by the judges and every effort should therefore be made to avoid it! As the model climbs away from the point of intersection, the loops (both inside and outside) should be opened out slightly to gain sufficient distance round the circle during the top half of the loop to enable the bottom half to be completed without being blown past the starting point. Remember that the model slows as it travels upwind during the top half of each loop, so be prepared for rapid acceleration during the bottom, downwind half. In windy weather this latter half of each loop must be very tight to avoid overshooting the centre of the eights.

It is equally important in the *square horizontal eights* that the centre vertical climb should always be in the same place, as any deviation is easily spotted. Let us first consider the shapes of the inside and outside square loops which make up the eights. The base angles of a normal square loop (previously discussed) were 100 degrees and the top angles 75 degrees. For the square eight the angles at the top and bottom of the centre vertical climb must be changed to 90 degrees (as stated in the rule book) to allow the inside and outside loops to coincide along the line. The other angles are unchanged and the top horizontal side of each loop is therefore slightly shorter than the other three sides.

The 'eights' start at the first corner of the inside loop. Make particular note of the position of the vertical climb using some fixed object (a distant tree, building etc.) as a reference. The model travels this same vertical line four more times during the two eights, hence the importance of marking its position. Ease off at the second corner keeping the included angle more than the rule book's 90 degrees. The model is travelling upwind during the whole of the inverted top leg and must reach the third corner with sufficient line tension to produce a very tight turn. The line tension available at this point depends largely on the flying speed, so again remember to keep that second corner 'loose'. The third corner needs to be tight, but not so acute as in the square loops since the model is further round the circle from the downwind

TWO SQUARE HORIZONTAL EIGHTS

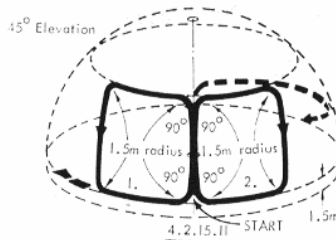

position and will be blown towards the centre of the 'eight' during the vertical dive. The fourth corner comes up very quickly as the model accelerates in the dive. Practice and good reactions on the flier's part are essential to produce a straight vertical dive followed by a tight fourth corner recovering smoothly at a height of five feet. It is common to see the third and fourth corners merged into one - the second corner can be the cause of this: if it is too sharp the model loses height along the top of the square and there is no space between the third and fourth corners. The next corner puts the model into a vertical climb again (did you use your marker?) ready to start the outside loop.

Now it is really important to maintain the model's speed. The first outside corner should be little more than a gentle nudge. Give yourself room, make the top of the loop too long rather than too short or it will be impossible to avoid overshooting the centre when the model returns inverted along the bottom of the loop. Now you are starting the second eight, notice how much slower the model is going now. For practice try doing four or more consecutive square eights and you will realise how important it is to maintain the flying speed. There is a natural tendency to make the second eight smaller as the model slows down. If this is a problem try making both eights larger. The manoeuvre finishes as the model completes the vertical centre climb for the fifth time - it is usual to do a further outside corner so that the model follows the top of the outside square loops before descending to normal level flight.

The *vertical eights* start as the model passes through the point of intersection of the inside and outside loops flying inverted at 45 degrees elevation, but how you arrive at this position is left open. However it is quite sufficient (and easiest) to do a half loop, and to continue round the same loop to start the 'eight'. Try to start the half loop slightly before the downwind point as the model will then be travelling upwind at the mid-point of the 'eight' and this helps during the start of the top outside loop. The size of the loops must be judged accurately so that the top of the figure passes through the point directly over the flier's head. In windy conditions a definite effort must be made to tighten up the descending half of the outside loop to prevent the model being

TWO VERTICAL EIGHTS

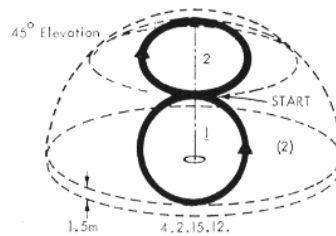

blown down below the 45 degrees elevation. If this happens the first half of the next inside loop must be very tight, but the imminent presence of solid ground is usually sufficient reminder! The second 'eight' finishes with the model inverted at 45 degrees elevation and a further half inside loop completes the recovery to level flight.

The *hourglass* requires both good reactions on the part of the flier and a good model. The first corner should be identical to the first corner of a triangular loop, not too tight - remember the included angle should be 67 degrees. This is followed by a long inverted climb. It is important to plan the position of the four corners in advance in order to achieve a symmetrical figure. The base of the hourglass subtends an angle of 50 degrees at the centre. The top of the figure is part of a wingover running parallel to the base and this top leg should be identical in length to the base so that at each top corner the lines should make an angle of 25 degrees to the vertical. The second and third corners are part of the only outside triangular loop in the schedule and also occur in a most difficult position when line tension is very low. There is no easing up here at the second corner - by all means keep the radius large but make sure that the change in direction is sufficient to bring the model through the point vertically overhead. Did you do the second corner too soon? Now wait, remember how long the top leg should be. The third corner can be as tight as possible and should bring the model round

ONE HOUR GLASS

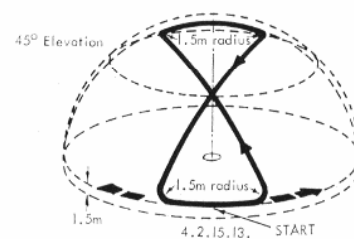

until it seems to be almost in horizontal inverted flight. The straight inverted descent should cut the vertical climb at 45 degrees elevation. Can you remember where the climb was? The last corner requires a steady nerve and much practice before a smooth recovery at the correct height can be achieved. Concentrate particularly on the symmetry of the figure. It is difficult to make the long straight climb and descent equal (which really means making all the angles equal) and no stunt competitor in Britain can achieve this consistently. Get it right every time and you will beat us all!

As with the horizontal and vertical eights the *overhead eights* start as the model first passes through the mid-point of the figure, vertically above the flier's head. The model should be pointing downwind at this point. Complete the usual two level laps after the hourglass then do a further half lap. At the upwind side of the circle turn the model into a vertical climb as in the reverse wingover but with a larger radius turn to ensure that you have line tension when the model is overhead. As in the wingover the flier has a choice of position. Right handed persons will naturally be facing upwind as the model enters the manoeuvre and will remain

CONTROL LINE

ONE FOUR LEAF CLOVER

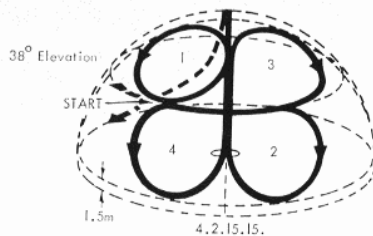

far too high upwind, almost doing a wingover in very windy conditions, and using the wind to blow the model into the correct position. Not a very tidy approach, but effective in 'desperate' conditions! It is inevitable in wind that the first loop will be started too late, so that the centre of the clover is no longer downwind. Note that the remaining three loops in the figure are in fact only three-quarters of a loop each. The level flight at 38 degrees elevation which follows the first loop is equal to the diameter of the loop – many people make it too short so that the left and right hand halves of the figure overlap. Next comes an outside loop at the bottom left of the figure touching the five foot level and finishing with the model in a vertical climb to the third leaf of the clover. If your positioning is good the model will be directly downwind but if you were late starting the first loop, the model will be slightly crosswind and care will be needed to ensure a truly vertical climb. The top left outside loop is not difficult, but be careful to keep it tight so that the model enters the inverted flight across the figure at 38 degrees elevation. Make sure the inverted flight is long enough before making the final inside loop at the bottom right. The model must then fly vertically through the centre of the four leaf clover and continue in a wingover into wind recovering into normal level flight.

* * * *

The schedule takes approximately five minutes to complete. Allowing around half a minute from the starting signal to takeoff, the four leaf clover should be completed after about five and a half minutes, leaving one and a half minutes for the motor to cut and the model to land. The interval is very short – life was much easier when a total of eight minutes was allowed rather than the current seven! Most people have to resort to some manoeuvring to stop the motor as once the tank is almost empty most models will stop sooner if flow high. Tight loops (but not eights) above the 45 degree elevation also starve the motor of fuel. My own technique is to use a stopwatch and having completed the schedule, to fly at normal level flight which keeps the motor as rich as possible using fuel more quickly. Then as late as possible, usually just before six and a half minutes, tight circles overhead after a rapid climb are generally effective in getting the motor to cut.

During the landing remember that the approach (that is the descent from five foot altitude) is marked as well as the actual touchdown – there should be an interval of one lap from the model passing through the five foot level to the point of touchdown. This means you must know one lap in advance where the model will land and pass over that point at a height of five feet. The landing itself depends very much upon the type of undercarriage used – with the more springy fuselage mounted system, three-point landings are essential. Rigid wing-mounted two wheel and tricycle systems

offer a choice of three point or main wheel landings as the model will not bounce (or should not!) when flown onto the ground at high speed. Always try to land downwind. Some whipping may be needed to achieve this, but stop whipping before the model touches down. In the quarter lap immediately after the upwind point the airspeed drops very rapidly so aim to land in this quadrant, passing the upwind point of the circle at about one foot altitude with just enough speed to retain line tension, in the case of a three point landing, or somewhat faster for a main wheel landing. Do not leave the touchdown too late since the airspeed starts to increase again before the extreme downwind point is reached and the model will float round into wind where a smooth touchdown is much more difficult. With two-wheel wing-mounted undercarriages the model tends to nose over if it stops facing downwind. It is wise to land with sufficient speed for the ground roll to take the model past the downwind point to come to a halt facing into wind. All this assumes that you are flying over concrete as in a competition, but if you prefer to practice over grass, both takeoff and landing are best made into wind.

* * * *

Let us now consider some general points about the flight. Remember that although marks are only given for the specified manoeuvres, your score is also affected by the overall impression that you make on the judges. I mentioned previously the need for a well organised starting procedure – the rest of your performance should be equally well organised. Be consistent with your hand signals and keep the level laps between manoeuvres at five feet. It looks untidy if the model flies too high and has to be brought down again to five feet to start the next item. Concentrate on each manoeuvre as you do it, forgetting about what has gone before. Do not let an early mistake have an effect on the rest of the schedule. It is of course important to remember what comes next, contest nerves can play tricks on your memory so if you are at all doubtful have someone in the centre with you to act as 'prompter'. At international events the Czech fliers, including a certain J. Gabris, always have one of their colleagues sitting in the centre with a list of manoeuvres. The most commonly omitted item is the triangular loops, so take care, you have been warned! In the heat of the moment it can even be difficult to remember how many consecutive manoeuvres you have done, particularly in the complicated figures such as square eights. Make a point of counting to yourself the number of loops or corners.

After a competition flight leave the circle quickly ready for the next competitor, then clean the model straight away before too much dust and grit settles on the oily surfaces. Make sure the lines are safe from other people's feet – it is always safer to put them away until just before the next flight.

In this 'guided tour' of the stunt schedule I have tried to reveal some of the hidden detail behind the manoeuvre descriptions in the rulebook. An article of this nature can anticipate and deal with the problems likely to arise in each manoeuvre but it is still up to the individual to acquire the necessary skill. Thus my answer to the original question 'How do you learn to fly stunt' is still the same. 'Go out and practice' – Hopefully, this article will make that task a little easier.

standing in that position. Some left handed fliers also face upwind. However my own (left handed) method is to stop turning about a quarter of a lap before the upwind point is reached, then as the model climbs up to the centre of the eights turn back to face downwind. Note the similarity here with the first half of the reverse wingover. The 'eights' must always start with an inside loop. To keep the shape correct open out the loop as the model flies the lower half into wind, touching the 45 degrees elevation at the lowest point. Allow sufficient distance to be gained upwind to come round to the centre of the 'eight' in the same direction as the original entry before starting the outside loop. It is not too difficult to keep the intersection in the same place but it is common for the transition from inside to outside loops

TWO OVERHEAD EIGHTS

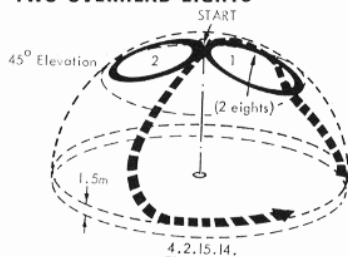

and vice versa to form a cross. The horizon is out of sight for most of the manoeuvre making positioning difficult. Try to pick out distinctive points in the cloud pattern overhead to act as markers, and stand still so that you do not become disoriented. Recovery from the 'eights' forms the second half of a wingover. The turn from vertical descent to level flight is not critical but it pays to be consistent; make a smooth turn equal in radius to a normal inside loop – such details give your flying a little extra 'style' and help to create a good impression on the judges – and that is important.

The last manoeuvre in the schedule is the *four leaf clover*. This is entered in level flight at an elevation of 38 degrees. It is possible to make the recovery from the overhead eights at a 38 degrees elevation ready to start the clover, but to my mind this is not good practice. It is best to be consistent throughout the flight, with at least some level flight at five feet altitude between manoeuvres, even though it is not the two full laps required by the rule book. The reason for the entry at 38 degrees elevation is that the whole figure is contained within half the circle, the model never passing behind the pilot's head. The two top loops are tangential not only to each other, but also to the vertical plane through the centre of the circle perpendicular to the central plane of the manoeuvre. The four loops are therefore smaller than other loops in the schedule, and the two top loops do not pass through the point vertically above the flier as in the vertical eight. Try to position the manoeuvre so that its centre is directly downwind. The first loop is the most difficult of the four, starting as it does high up in the circle with the wind behind the model. It is essential to reach the entry point with as much flying speed as possible in order to maintain adequate line tension over the top of the loop – this is difficult in wind as the model is blown downwards as it approaches the start of the figure. I get over the problem by climbing

HINGING METHODS

KEEP THAT ELEVATOR/TAILPLANE JOINT FREE 'N' EASY

THE HINGE between elevator and tailplane, or flap and wing is essentially a very simple device. Unfortunately, being so simple it is frequently not given sufficient attention, especially by the beginner, and stiff control surfaces are all too common. Ideally, an elevator should drop down under its own weight if released from the neutral position when the control lines are slackened. Remember, that while the model may fly satisfactorily when the engine is running well and the lines are tight, it can be a very different story when the engine dies out at the top of a loop, the lines go slack, and you are panicking! Binding hinges make control impossible under conditions like this, so take a little care in their installation.

The sketches drawn opposite shows various methods of hinging – each has their own merits, and demerits! In general though, bear the following points in mind:

(a) When adding tape or stitched hinges, it can be useful to clamp the elevator and tailplane together. If they are both from sheet balsa – frequently 3mm sheet – then Bulldog clips may be applied at either tip.

(b) Tape hinges are susceptible to being gummed up with paint or fuel proofers, but if the hinge line is wiped over with Silicon Muscilage (available from fishing tackle shops) then the paint will not affect it.

(c) The wire/brass tube variety are susceptible to paint or glue intrusion – apply a drop of thin oil or Vaseline to prevent this.

(d) The above type of hinge, plus the commercial moulded nylon variety must be aligned accurately in the control surfaces, or else they will bind. Draw the hinge line on the exact centre line of the elevator/tailplane, and be careful!

(e) For safety, it is recommended to 'peg' commercial nylon or mylar hinges after installation. This may be done with cocktail sticks or even pins, snapped off flush with the surface. Its plastic film covering is employed, then these pegs can be hidden using the method shown in Figure 1.

(f) Whatever type of hinge is used, remember that every one installed means *some* friction, so do not add

more than is necessary. In general, four hinges per elevator is adequate – one set in around 1in from each tip, and two more either side of the centre line – usually about 1in outside the

fuselage area. The same applies to tape hinges or stitching – a 'pivot area' around 1–1½in long repeated four times as described is usually sufficient.

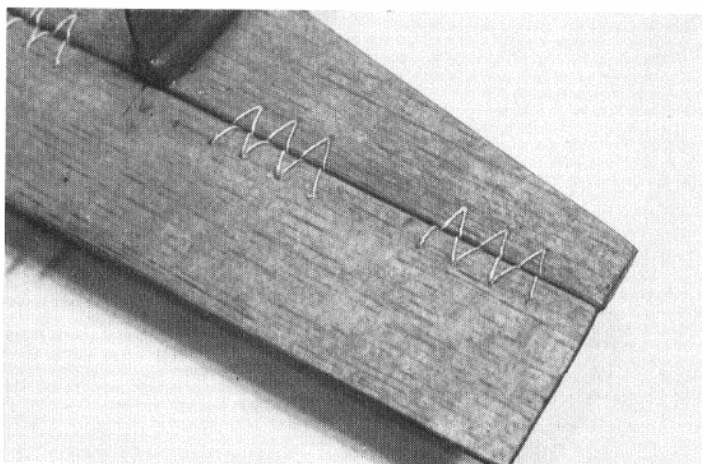

Typical stitched elevator/tailplane (above) reveals the stitching does not extend full span, and that the sewn area is set in from the tip.

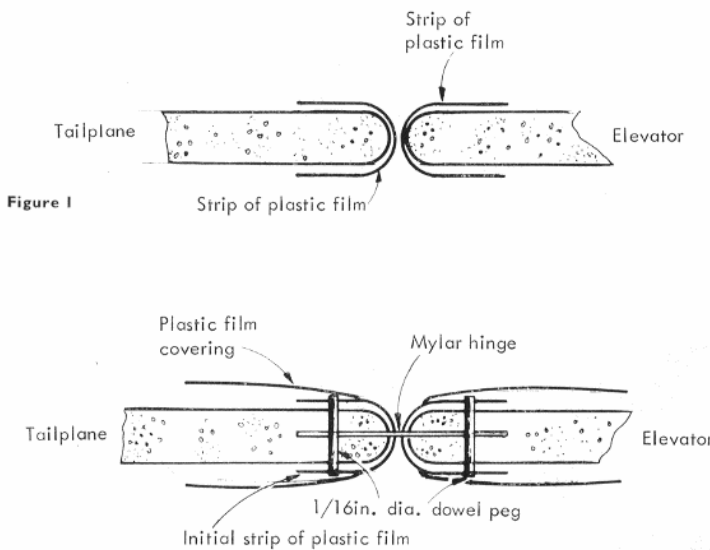

TINPLATE/WIRE HINGE

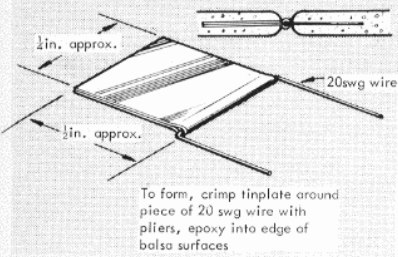

To form, crimp tinplate around piece of 20 swg wire with pliers, epoxy into edge of balsa surfaces

BRASS TUBE/WIRE HINGE

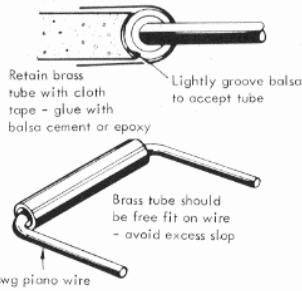

Retain brass tube with cloth tape - glue with balsa cement or epoxy
Lightly groove balsa to accept tube
Brass tube should be free fit on wire - avoid excess slop

18 swg piano wire

CAUTION - The three types of hinges drawn above are susceptible to being stiffened by adhesive or paint and fuel proofers. Lightly oil or Vaseline to prevent this, and apply the minimum of adhesive necessary for secure mounting. Wipe off any excess immediately.

Cross section through hinge

COMMERCIAL R/C HINGE

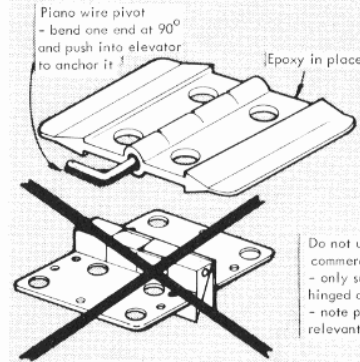

Piano wire pivot - bend one end at 90° and push into elevator to anchor it!
Epoxy in place

Do not use this type of commercial hinge - only suitable for top hinged ailerons or flaps - note position of pivot relevant to hinges

PLASTIC FILM COVERING HINGE

STAGE 1

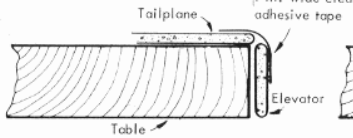

STAGE 2

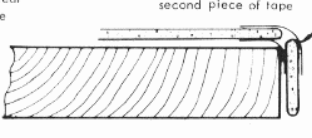

STAGE 3

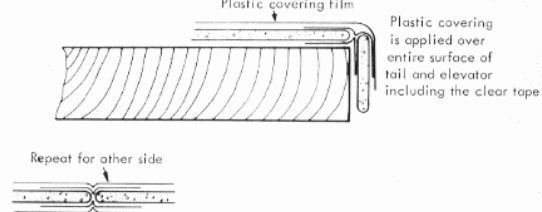

NOTE: Tailplane and elevator are hinged at 90° to one another in order to provide free movement after final film covering is applied

SEWN HINGES

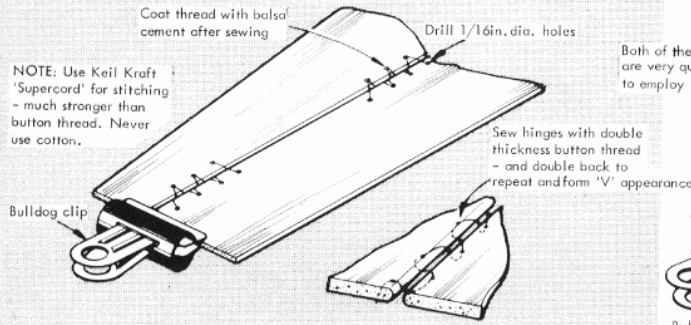

NOTE: Use Keil Kraft 'Supercord' for stitching - much stronger than button thread. Never use cotton.

Coat thread with balsa cement after sewing
Drill 1/16in. dia. holes
Sew hinges with double thickness button thread - and double back to repeat and form 'V' appearance

Both of these methods are very quick and cheap to employ

CLOTH (OR NYLON) TAPE

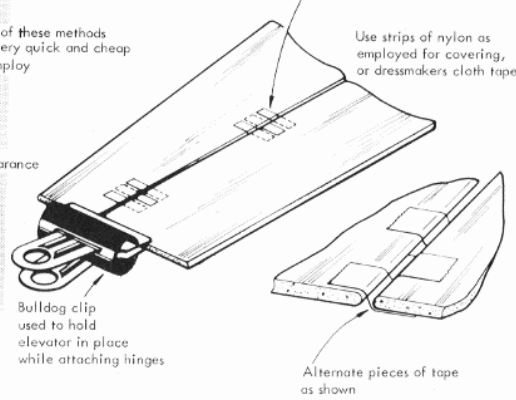

Use strips of nylon as employed for covering, or dressmakers cloth tape

Bulldog clip used to hold elevator in place while attaching hinges

Alternate pieces of tape as shown

COMMERCIAL MYLAR STRIP

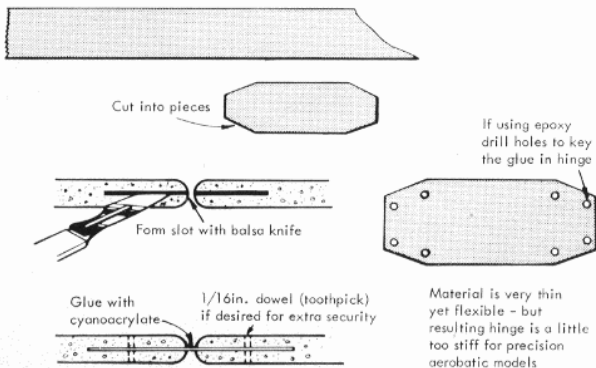

Cut into pieces
Form slot with balsa knife

If using epoxy drill holes to key the glue in hinge

Glue with cyanoacrylate 1/16in. dowel (toothpick) if desired for extra security

Material is very thin yet flexible - but resulting hinge is a little too stiff for precision aerobatic models

COMMERCIAL NYLON HINGE

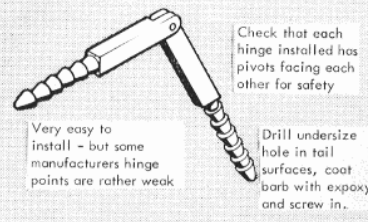

Check that each hinge installed has pivots facing each other for safety

Very easy to install - but some manufacturers hinge points are rather weak

Drill undersize hole in tail surfaces, coat barb with epoxy and screw in.

BREW - IT - YOURSELF

BY DAVE CLARKSON

WHATEVER motor you use, and whether you buy ready-made fuel or mix your own, a little knowledge of the fuels we use is most helpful. Therefore the intention of this article is to spread a little knowledge on fuels with the hope that the uses, limitations, and safety aspects of commonly used fuel constituents are better understood, perhaps resulting in fuel cost savings, improved motor performance and/or life, or just peace of mind.

Obviously the main benefit of this article will be for those of you who mix your own fuel. I, like many others, mix my own and have done so for years: the reasons being to save money and to be sure that I will get the best in both terms of performance and life out of my (expensive) motors. The same motivations must apply to most, if not all, model aero engine users, so this article is directed towards the 'home brewer'. This is not to say that commercial ready-mixed fuels are inferior, in fact I am sure that the vast majority of fuels sold are perfectly satisfactory. However, when done with care and knowledge, 'home brewing' of fuels can save money and give improved results in many cases.

The coverage given is limited to readily available fuel components only – there seems little point in discussing for example, epoxidised soyabean oil, when only a tiny minority can obtain it. Similarly exotic and/or extreme mixes will remain a mystery!

OILS

Oil is common to all fuels, and there is little evidence that glow and diesel engines differ much in their requirements. There are three basic groups of oil depending on their origination:

Mineral Oils (typically motor car lubricating oils) are refined from crude oil and are the cheapest oils available. Unfortunately their thermal stability and film strength etc., are not of the best, so additives are necessary to give satisfactory performance. In motor car oils the additives are frequently based on metallic compounds (remember the Castrol 'liquid tungsten' advert) and

when they burn can leave abrasive metal oxides behind – definitely bad for 2-stroke engines. So **DO NOT USE CAR OILS UNDER ANY CIRCUMSTANCES**. 2-stroke motor cycle oils do not include such metal based additives, so they can be used, but are not recommended for they simply are just not as good as vegetable or synthetic oils. Besides this, all mineral oils when burnt (as occurs in all 2-stroke engines) leave behind sooty deposits meaning frequent de-coking of motors – altogether bad news. In any case mineral oils are not miscible in the normal fuels used for glow motors.

Vegetable Oils are the traditional model aero engine oils for the excellent reason that experience has shown that certain vegetable oils, particularly castor oil, are totally satisfactory in our engines. In this country only castor oil is readily available in a suitable form for our use, basically because for most applications, castor oil is without doubt the *best* vegetable oil. When selecting castor oil do choose one intended for lubricating purposes; castor oil is used in large quantities as a chemical feedstock, and as a pharmaceutical or perfumery constituent. These non-lubricating applications for castor have industrial specifications written all about colour, cleanness, purity, etc., but *not* lubricating properties, and can be pretty poor as lubricating oil. Remember that castor oil is a natural product and is therefore, highly variable in quality – if you have heard bad stories about synthetic oils, I could match them with stories about medicinal and perfumery grades of castor oil! Since castor is freely available in grades selected for correct viscosity and optimum lubricating properties (see 'sources of supply') there is no point in *not* using one of these.

Castor oil is not cheap, so do not waste money by using more than 25% in your fuel mix. Equally, using less than 20% can lead to problems on a 'lean run' unless you know what you are doing.

Castor has one problem in that it burns to leave a lacquer-like deposit. This is not totally bad, for a slight coating of this lacquer on the liner

and piston walls helps maintain compression during the normal wearing process. However too much lacquer (i.e. when the motor is thoroughly black inside) can give poor starting and reduced performance. Therefore, when starting and performance distinctly go 'off' and your motor is 'black' inside, gently de-lacquer the piston and liner walls using a worn 'Scotch-Brite' pad and warm soapy, water, and then wash, dry and oil the motor thoroughly before re-assembly. The motor stripping and de-lacquering is not good for the life of your motor so do not do it until it becomes absolutely necessary – if the motor is 'black' inside but still starts and goes well, then leave well alone!

One final point to remember with castor oil is that sometimes, when stored as recommended later in this article in an unheated garden shed or garage, and when the oil has got very cold due to winter temperatures, white specks or a white cloudy layer may form in the oil. Some of these specks consist of high molecular weight fatty acids and add to the lubricating qualities of the oil. If your oil forms white specks or a white cloudy layer, move the can to a warm room for a few days and the specks/cloudiness should disappear.

The same can happen in castor oil – only containing fuels. However with mixed fuels, storing in a warm room is definitely *not* recommended and filtering will remove some lubricants from the fuel. The moral, in winter at least, is to mix up only enough fuel as you need for each flying day, on the day.

Synthetic Oils are chemically similar to vegetable oils so can give similarly excellent lubricating properties. However synthetic oils possess two particular features not found in vegetable oils. The first of these is that synthetics are relatively very pure, so they burn leaving no deposits whatsoever. In fact, at a precise temperature (depending on the particular synthetic oil used) complete chemical break-down occurs into flammable gases (like alcohols) only. For most synthetics this temperature occurs in the narrow range of 215°C to 225°C. If the magic temperature occurs in your motor *above the piston*

crown then your oil has become good fuel and extra power/economy is the result. If, on the other hand, the 'magic' temperature occurs *on the piston wall*, utter disaster – for suddenly all lubrication disappears – and so will your piston only, a little slower! G-MAX ML 70 contains a non-metallic additive to counter this and has a much higher chemical break-down point – 260°C. The second difference is that in glow-fuels, castor oil and nitro-methane do not mix when more than about 50 per cent nitro is in the mix. Not good! However, synthetic oils and nitro-methane mix in all proportions, and this is one reason why speed fliers in particular have really taken to using synthetic oils.

A mixed picture therefore, with synthetic oils – excellent lubrication and mixing properties but with potential disaster always possible if your motor gets too hot, and because of the large number of possible types of 'synthetic' oil, this must depend upon which one you use. For the contest fanatic, the extra power/economy available is very attractive and many take the risk to get this. For the non-contest flier, there seems little point in using synthetic oils because of the inherent risk potential involved. Before I leave synthetics, I will confess that for some years I have used a 50/50 castor/synthetic oil mix in diesels with total satisfaction – no

disasters and improved performance plus really extended periods between motor de-lacquering. Likewise in glow engines I and many others have found that 5 per cent castor plus 15–20 per cent synthetic oil give minimum (no?) risk plus maximum performance. Try these castor/synthetic mixes if you want, experience has indicated that they really work very well indeed, just as experience has indicated that of the few synthetic oils available here – G MAX ML-70 – is by far the best, and possibly the only one worth using.

GLOW FUELS

Starting with 20–25 per cent of castor oil or 5 per cent castor plus 15–20 per cent ML-70, what about the rest? Alcohol plus nitro of course but which alcohol and why nitro? And should anything else be used? Let's deal with these questions one by one.

Which Alcohol? Methyl Alcohol, better known as 'methanol' is the standard choice. At this time, more methanol is made than any other alcohol by a wide margin, so it is the cheapest and most available and this will remain true for the predictable future; indeed our cars may well be running on methanol in the not too distant future. Methanol is manufactured, usually from natural gas (North Sea Gas), in enormous plants

producing up to 1,000 tons per day each – ICI does this on Tees-side for example. The industrial quality is excellent, quite adequate for our use. The only problem with methanol is that it is a demon for absorbing water from the atmosphere – the air *always* contains water; in the UK usually between two and 15cc per cubic foot of air – so the older methanol gets, the wetter it gets, particularly if you leave the cap off the bottle. Wet methanol bangs out glow plugs, reduces performance, etc., so *keep the cap on the bottle*.

One other precaution here. If you are offered a very cheap source of methanol, make sure that it is not industrial 're-claimed' methanol. This is methanol that has been used for cleaning purposes and then mixed with other chemicals to purify it. Unfortunately, whilst the methanol may be fine for cleaning use once again, it is most certainly not suitable for our purposes. As always, be careful of any item offered at a low price.

The only other alcohol which can be used is Iso-propyl Alcohol which gives a little less power but significantly greater economy. Better known by its initials IPA, it can be used as up to 60 per cent of your glow fuel if extra economy is desired, but IPA costs a lot more and is not as readily available.

Why Nitro? Oxygen is necessary for combustion and nitro has a lot of it. Adding nitro is like putting a super-charger on your car – extra power. Not all of us need, or want, extra power so why is nitro (in my view) necessary? The fact is that a little nitro, say 5 per cent, makes nearly every glow motor a lot easier to use, the motor runs more smoothly, the needle valve setting becomes less critical, glow plug selection becomes less critical. All very good reasons for using a little nitro. If you want extra power, then using increased nitro is the easy way to it – 'tipping the can' is what the Americans call it. However, nitro is not cheap. Only one company in the world at this time makes nitro-methane in big quantities; that company is in the USA and there is only one authorised agent for distributing the stuff here. It does not need 'A' levels to see why nitro is not cheap here, but at least the price is still within reason, and availability is no problem in the UK – in many countries nitro is not available or prohibitively expensive, so we do not have too much to moan about.

Alternatives to nitro-methane do exist, for in the manufacture of nitro-methane, large quantities of nitro-ethane and particularly nitro-propane



are made. These are industrial chemicals usually only available in bulk (i.e. 200 litre drums) but can be cheaper than nitro-methane so some commercial mixed fuels do contain proportions of nitro-ethane and/or nitro-propane. Both nitro-ethane and nitro-propane have the same effect as nitro-methane but you need more to get the same result and motors tend to run hotter on them. In general terms, nitro-ethane is 40 per cent as effective and nitro-propane 35 per cent as nitro-methane, and no real cost saving results because you have to use more (unless the reason for adding nitro to the mix is not to increase performance but just to write 'x' per cent nitro on the can, as has happened in the past . . .)

Most glow-motors are designed for low-nitro fuels and need modification to operate successfully on more than the manufacturer's recommended fuel nitro content. By 'low-nitro' I mean 5-10 per cent nitro-methane. Unless you know what you are doing mixing 40 and 50 per cent nitro fuel is one big waste of money. Stick to low-nitro and save money! 1977's biggest prize-money combat contest in the World was won on 10 per cent nitro-methane fuel.

Are there any other additives?

An absorbing subject for the fuel chemist and some illustrious articles have appeared in the past on this subject. 99 per cent of us never need to use any other additive in glow fuels than the standard components discussed above, so forget them and quietly snigger when someone bends your ear with stories of his new 'wonder' additive. A rather bald statement, but one that is true for all

except people who want to use 70 per cent nitro-fuels where 10 per cent of propylene oxide sometimes helps to 'fire off' this priceless mix.

Standard formulae? Mine are:

'Club Field'

| | |
|---------------|-----|
| Castor Oil | 20% |
| Nitro-methane | 5% |
| Methanol | 75% |

Combat

| | |
|---------------|-----|
| Castor Oil | 5% |
| ML-70 | 15% |
| Nitro-methane | 10% |
| Methanol | 70% |

Goodyear*

| | |
|---------------|-----|
| Castor Oil | 5% |
| ML-70 | 15% |
| Nitro-methane | 40% |
| Methanol | 40% |

*Note: a modified engine is frequently necessary to burn this fuel successfully.

DIESEL FUELS

Oils are as discussed before, and the rest really is simple – just ether plus paraffin plus an ignition improver.

Ether Correctly 'technical grade di-ethyl ether'; speak thusly to your friendly chemist and he may actually sell you some. That really is the problem – persuading a chemist to sell you it, it being 'technical grade di-ethyl ether'. However there are also other sources – see appendix. Ether is not cheap so do not use more than necessary and the invariable range is 30-35 per cent in your brew. More is a waste of money and less

will give starting/overheating trouble. 'Nuff said? I think so.

Paraffin In this country paraffin means 'Esso Blue', 'Aladdin Pink' etc. – countless names, approximately one to each petrol company! The only real difference between them all is the colour. Instead of paraffin, people have used TVO, DERV, AVTAG, etc. and found them no better, and usually worse. Paraffin is the cheapest and most available diesel fuel component so do not stint on it. In other countries where paraffin domestic heating stoves are not so common, paraffin assumes other names, qualities and availabilities. My own experience is that paraffin sold for domestic heating by direct combustion (like ours is) is the least 'oily' of all varieties. A typical example is America where the 'kerosene' available is intended for storm lanterns and is surprisingly oily, so oily in fact that it leaves carbon all over the place in diesels, and the lubricating oil content can be happily reduced to 15 per cent or less. Not the case here though! My advice to all is to stick to one supplier and type of paraffin, because commercial paraffin specifications are wide and variations can occur – I believe it when someone tells me that garage 'A' sells 'very good' paraffin. Who is it who sells purple paraffin? Horrible colour it gives the fuel, don't you think?

Ignition Improver An absolutely essential constituent of any diesel fuel (if you want to run your motor at over 10,000 rpm) The ether-paraffin-oil base of diesel fuel does not ignite easily enough for satisfactory burning at normal motor speeds. Fortunately the same problem occurs on big static diesel engines when cheap, heavy fuel oils are used, so commercially available are Ethyl Corporation's 'DII' (*Diesel Index Improver*) in the USA, and ICI's 'IPN' (*Iso-Propyl Nitrate*) in the UK. Both are organic nitrates – DII is a mixture and IPN just one. These are vastly cheaper than the traditional ignition improver Amyl Nitrate (or Amyl Nitrite) available at some chemists. All work; my favourite is IPN because it is cheap. Unfortunately ICI like to supply IPN in 200 litre drums and it needs a lot of sweet talking to get just 20 litres out of them. Enormous quantities compared with what we need, so many of us just toddle down to the chemist for amyl nitrate and convince him we do not drink the stuff (it is a heart stimulant), instead we feed it to model aero engines (take one along,

SOURCES OF SUPPLY

Halfords, or specialists motor cycle shops.
Griffin and George Laboratory Supplies
(local branches listed in 'Yellow Pages')

G-MAX, Order through your model dealer anywhere in UK or Ireland. Some collections can be made by arrangements in Rushden, Northants – phone Rushden 56845. If not possible order by phone or letter only from G-Max Research Co. Ltd., 8, Tate Road, Sutton Surrey Tel. 01-642 8971

MODEL TECHNICS. Order through your model dealer in UK or Ireland. Alternatively order direct from Model Technics Ltd., Vanguard Way, Shoeburyness Essex. SS3 9QY Tel: 03708 – 2244, or collect

Local chemist.

Enquire at a C/L Contest

Castrol 'M' castor oil

Ether, methanol, IPA.
most chemicals.

Ether, Methanol,
nitro methane, propylene
oxide, ML-70 synthetic oil
Iso-propyl-nitrate (IPN)
pure castor oil.

Castor oil, Methanol
nitro-propane, nitro
methane, IPN.
Cetane improver, ether

Ether, amyl nitrate
IPN

he may believe you). DII, IPN, Amyl Nitrate, all seem similar and 2-2½ per cent is all you need. Again, see the appendix for a supplier.

A bit of technology exists as to deciding on the correct proportion of ignition improver to use. Basically, if your compression setting 'wanders' and your motor tends to get 'hot and hard', your fuel contains too much ignition improver. If your compression is very critical to set and/or the motor is prone to a high-speed miss-fire, your fuel contains too little. 2-2½ per cent should be right but you may have to stray up to 3 per cent or down to 1½ per cent if your motor is at all unusual.

I do not know of any other useful additive: I doubt whether more than a handful of people in England use any other diesel fuel additives than the ignition improvers mentioned.

Standard Formulae?

'Club Field'

*Castor Oil 3 parts
Paraffin 5 parts
Di-ethyl ether 4 parts
Iso propyl nitrate +2%

Racing

*Castor Oil 20%
Paraffin 50%
Di-ethyl ether 30%
Iso propyl nitrate +2½%

* Actually I use 10 per cent castor oil and 10 per cent Shell 'Oxylube 83/140' instead of all castor. The Shell oil is a synthetic, not sold as an oil at all - I just happen to have a quantity of it, and it works very well indeed, for me anyway.

SAFETY

Storing and mixing fuel components and fuels is definitely a business that needs consideration of safety. Below are summarised the hazards associated with the common fuel components discussed in this article.

If the table contains some surprises for you, it should not. Many people will look at the potential hazards involved and decide that someone else can do the job, and that is one of the things you pay for with commercial fuel blenders. However, if you are careful, and take sensible precautions, the hazards will remain 'potential' and not become actual. The basic precautions are:-

- (1) Store only the minimum quantities you need.
- (2) Only use good condition metal cans for storage and mixing although heavy duty polythene containers are better for Alcohol and Nitromethane. The caps

must seal tightly. Do not fill cans more than three-quarters full.

- (3) Store only outside any inhabited building, typically in a garden shed or garage. No artificial lighting or any source of heating to be in, or near, the store. Store must be well ventilated. **DO NOT SMOKE IN STORE.**
- (4) Do all mixing out in the open air. **DO NOT SMOKE WHILST MIXING.**
- (5) Always have at hand a bucket of water and a bucket of sand.

Immediately wash away all spillages with water. Never pour water on a fire (except Alcohol and Nitromethane) - dump the bucket of sand on a fire **AND THEN RUN.**

- (6) Always have someone near who knows what you are doing when you are mixing fuels.
- (7) If you do not know what is in a can, or it seems to have 'gone off', discard the contents immediately.

Think about this list. All sensible stuff really, and well within the scope of just about all of us.

HAZARDS ASSOCIATED WITH FUEL COMPONENTS

| Component | Flammability | Toxicity | Remarks |
|-----------------|----------------|----------------|--------------------------------------|
| Castor Oil | Low | Low | Will support a fire |
| Synthetic Oil | Low | Low | Will support a fire |
| Methanol | High | High | Very Poisonous |
| IPA | High | High | Definitely not drinkable! |
| Nitro-methane | Medium | Low | Do not use dry powder in fire |
| Propylene Oxide | Extremely high | Medium | Almost an explosive |
| Ether | Extremely high | Medium | Very low flash point/ an anaesthetic |
| Paraffin | Medium | Low | |
| IPN, DII etc. | High | Extremely High | Heart Stimulant |



A ROSE BY ANY OTHER NAME

BY IAN PEACOCK

"COSMETIC SURGERY" is a phrase much accepted in today's trendy society where many thousands of pounds are spent each year to enlarge, reduce, improve, or just simply alter, the appearance of people and products subjected to public scrutiny. Actors and actresses change the shape of their faces and bodies to project an "image" for the fans just as the manufacturers of more tangible goods give the product a periodic "face lift" to restore flagging sales. Once the glossy exterior is stripped away, "this year's model" often reveals the same basic product as last year, indeed often the same as the last ten or more years.

So, too, with model aircraft. The more studios amongst us readily noticing the marked similarities among certain classes and types of model. Competition rules tend to breed a "class" of models which exhibit these similarities, after all they are all striving to achieve much the same result, and perform the same function. Despite this, however, the longer term influence of the more famous designs can be seen filtering down through the years, and their characteristics are easily recognised in many of today's models. The blatant and obvious points of this heritage are not, however, completely necessary and many a cunning modeller has hidden the parentage of his creation by techniques of disguise that make the model appear to be totally new. In fact 'cosmetic surgery' is an everyday part of the model-making scene as well!

Maybe it would not fool the scale enthusiast but the author's conversion of his Veco Thunderbird certainly looks sufficiently like a Spitfire for most people.

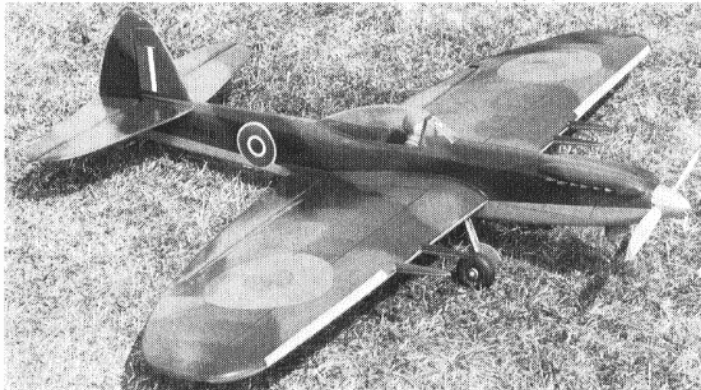

60

To illustrate more clearly, consider the case of the *Thunderbird* and *Nobler* – two of the world's classic C/L stunt models. This is not to say that other areas are free from plagiarism, simply that these examples serve well to illustrate the point.

Now both these models appeared in the early '50's and have, over the years, notched up more contest wins than we care to remember. Countless variants have appeared, with and without success, and both have been so successfully kitted that they are still in production today. Indeed the *Nobler* has even been adapted to R/C stunt!

What we would like to demonstrate here is just one way to change the appearance without altering performance. This latter point is worthy of further explanation. There is little point in changing the shape of a model and *reducing* the performance and whilst the 'experts' may improve the performance, to many of us such design changes are out of reach. Sufficient, therefore, is the desire to change the shape and *maintain* the existing performance.

The Veco *Thunderbird* was the design of the great Bob Palmer and was a revelation to us all in Great Britain. C/L stunt was still in its infancy and Pete Russell's *334G* powered by a 2.5cc diesel was much in vogue. The 35cu in glow motor in such a large model was a major breakthrough and those of us who saw Bob demonstrating the 'T-bird' in this country early in the 1950's will never forget it. The kit was very advanced for its day, and

even by today's standards it is still very good. At the current price of around £17 it can be obtained from most good model shops and offers good value for money. The kit is currently produced by **Dumas** in the USA and distributed in the UK by *Irvine Engines*.

Of similar vintage is the **Topflite Nobler**. Designed by George Aldrich, the *Nobler* has an even more distinguished record, having more contest wins to its credit than any other aircraft! Like the *T-bird*, it is still in production – current UK price is around £20 and it is available from most good shops (for the R/C enthusiasts the R/C *Nobler* could also be cosmetically treated in a similar manner). Both versions of the kit are distributed by *Ripmax*.

THUNDERBIRD

The *Thunderbird's* wing platform is partly elliptical with a straight leading edge and therefore bears a marked similarity to many classic WWII fighters such as the *Spitfire*, *Tempest*, *Typhoon*, *Sea Fury*, *Thunderbolt* and many more. We opted for the *Spitfire* – the later versions with the bubble canopy. Our line of thought over design changes was one of deliberately *not* altering the prime points affecting performance, i.e. wing and tail areas, all moments, incidence angles, CG etc. With this in mind the wing and tail were built directly as the kit instructions. It was decided to move the U/C from the fuselage to the wing for appearance, but to angle the U/C legs forward to ensure that the position of the wheels remained unchanged. 10swg piano wire legs were made and sewn and glued to a 3mm ply plate fitted flat in the wing between the ribs (see *Figure 1*). Now came the difficult bit. The T-bird plan is more of an 'illustrated construction guide' rather than a true plan, but using the die-cut fuselage sides and tail as a guide, a side view of the fuselage was drawn onto the back of an old roll of wall paper. In the corner of the plan is a small scale 3-view which helped in the drawing of this side elevation. Now, using photos of the real aircraft as a guide, the side view of the 'Spitfire' was penciled in, taking care not to alter the relative positions of motor, wing and tail. A certain amount of

CONTROL LINE

fiddling was necessary in order to 'fit' the Spitfire outline around the existing profile, and we found that pinning the drawing on the wall and standing well back from it enabled us to get it right by eye rather than by ruler.

The basic fuselage was seen to need little alteration to achieve the correct result. More obvious however were the change in profile of the fin and rudder, the fitting of a larger canopy (and fitting it further back!) and a profile change of the nose area. The prominent blisters on the nose of the Spitfire were added together with dummy exhaust stacks carved from balsa block. The entire aircraft was then assembled and quite honestly looked terrible, but do not despair – just press on!! Once tissue covered and doped it began to look better and extra detail was added. This, though, is the time to stop and think again. Too much detail will add weight and we wanted to stay within the recommended weight to ensure good flight performance (38oz is recommended). Another factor that worried us was the possible aerodynamic effect of the large blisters above, and coolant radiators below the wings. Eventually common sense prevailed and they were omitted, the only wing detail added being the cannon (made from balsa dowel). Basically then, only a few parts were discarded, predominantly fin, rudder and cowling, and not a lot of expense was incurred in new wood.

The most important point, to our mind, in any semi-scale model is that of paint scheme. If one produces an accurate camouflage, both in colour and pattern, together with accurate style and colour of markings, the eye of the onlooker is drawn away from inaccuracies in outline. Accordingly the entire airframe was clear doped and then airbrushed in matt cellulose to the exact shades using the dark grey/dark green topside and pale grey underside scheme common at the end of WWII. Roundels were drawn in



Tom Jolley converted the classic Nobler into a very attractive semi-scale Midget Mustang, without spoiling the aerobatic performance.

Humbrol matt enamels using a draughtsman's compass fitted with a pen. Size and proportions of roundels are important and these were checked with reference books to ensure accuracy. Serial numbers were added from black transfers and walkway and panel lines added in indian ink. No Squadron codes were used as many late mark Spitfires flew without them. However, just as many did have them and they could be added from transfers or from strips of painted adhesive tape if desired. Final fuel proofing was with K&B epoxy (also available from *Irvine Engines*). This finish is available in both gloss and matt clear, and the matt finish suits most WWII aircraft. (Purists here might disagree as many of the later Spitfires were highly polished – however, the choice is yours.) As can be seen from the photographs, little of the *T-bird* is obvious in the finished model.

NOBLER

The second conversion is shown by kind permission of our good friend Tom Jolley who used it most successfully to win the Gold Trophy at the 1967 Nationals and who also provided the historical facts. Few but close friends knew of the origin of

Tom's *Midget Mustang*, a stunter based on the well known full size pylon racer, but now it can be told! Due to an ill-timed mishap with an earlier model Tom was faced with building a new model with only a very short time between the aforesaid mishap and the 'Nats'. After some thought a *Nobler* kit was purchased and 'breathed upon' to create as near a copy of the racer as was possible. So successful was this ploy that the *Midget Mustang* was published in a leading American magazine, the Editor being blissfully unaware that the origins of the model were so close to home!

Once again the undercarriage was moved into the wing, although the legs were fabricated from dural strip, revised wing tips were added and the entire wing surface sheeted with soft 1.5mm balsa. (The kit is part sheeted and part capstripped.) The fuselage outline had a similar treatment to that of the *Thunderbird* to acquire a scale-like profile without altering the relevant positions of wing, tail and motor. A new canopy and apple-cheek cowls were added. The fin and tail plane outlines were adjusted to look as near as possible without any actual change of area. Finish on the model was of the time honoured method of tissue, dope, sanding sealer and elbow grease. Final colours were metallic pale green with dark green trim, both colours coming from the range of car cellulose used by a well known British car manufacturer.

Although we have seen many *Nobler* variants before and since, we do not think that we have ever seen quite such a successful adaptation.

There it is then – try it for yourself – it is not really very difficult and there is a great sense of satisfaction when you turn up at the flying field with your 'own design' built from someone else's kit.

Figure 1
Make sure leadouts are not fouled by new undercarriage position

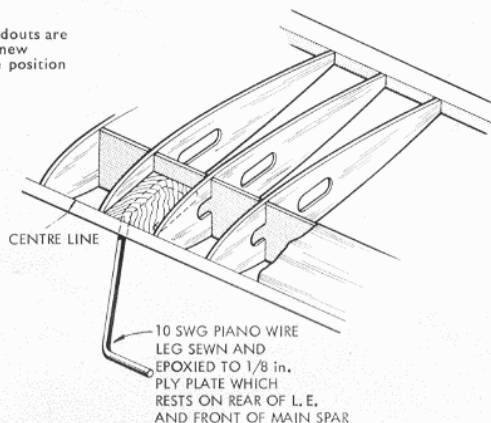

FLY - FOR - FUN SCALE

BY PETER MILLER

The Jurca Tempete, a French home-built light aircraft, is a typical example of the author's approach to 'fun scale' modelling.

ASK THE average sports flier why he does not fly scale models, and in most cases you will get one of the following stock answers: "They don't do anything; they are harder to build; they don't fly so well or they get damaged easily." With the majority of scale models seen one or more of these answers will be true, but this need not be so. Aerobatics, throttle control, operation from water and many other flight functions can be carried out with a model that is easy to build.

The design philosophy of simplicity, lightness and fun has resulted in scale becoming almost as popular as stunt in the Sudbury Model Flying Club, while some of the scale models in the club have been providing real flying "fun" for years. The purpose of this article is to pass on this design philosophy and to encourage others to try scale models, it is not intended to teach design principles but is aimed at the person who can design a sport stunter. However, there is no reason why a scale model, built on the lines suggested here should not be chosen as a first design, the unconventional *Stipa Caproni* was a first 'own design' by John Gudge, which proves that it can be done even with exotic subjects. This model followed the basic principles of lightness, simplified construction etc and is great success.

Before we start the process of



selection of a subject, there is one vital point that must be borne in mind from the first look at a 3-view drawing until the last lick of fuel proof is on the model; *low wing loading*. Whether you want an aerobatic model or one that will do gentle touch and goes on grass, or just a model that is a dream to fly, the answer is *lightness*. In fact, the scale modeller could do well to adopt the motto "simplificate and add lightness".

Now we are ready to start looking for a subject to build, what should we look for? The normal top priority is a model that one likes, however if it does not have most of the desired features then it should be discarded ruthlessly. It should have simple lines, preferably a basically box fuselage with a minimum of compound curves (fabric covering in large areas is a great advantage) while wing area should be reasonably large or the design feature high aspect ratio. When the prototype is a bit short on wing area it is sometimes possible to make the model larger as wing area increase in greater proportion than other dimensions. The undercarriage should be located in line with, or forward of, the wing's leading edge.

One can rule out most World War II fighters and racing aircraft, the best fields to search are private aircraft, homebuilts, biplanes and the growing

range of agricultural aircraft. Multi engine subjects should not be ignored as many of them have all the requirements for fun flying, plus the bonus of two or even four engines. The latter are not likely to be chosen as a first scale model, but a four engine model with two dummy props can be the answer here.

There are literally thousands of perfect scale subjects, far too many to list here, but let's look at a random selection to get some idea of the sort of plane to choose. In the light plane field we have the *Jurca Tempete* which is possibly the easiest subject of all, the *Piper Cherokee* range for colour and tricycle gear, or for the same type how about a *Victor Airtourer* to be different? The *Piper Tri-Pacer* is unusual, it has vast areas of fabric covering, a trike landing gear and should be stunnable with a suitable wing section. If a biplane is your dream, the *Isaacs Fury*, *Bucker Jungmeister*, *Meyer Lil Toot* or *Pitts Special* could be good subjects - the last two would be quite aerobatic. On the subject of aerobatics, there are a few aircraft that fit the proportions of a contest stunter to perfection! The *Curtiss S03-C*, *Douglas Devastator* and the *Short Seaweb* to name but three.

Of the many twin engine models that are suitable, one must be supreme - the *Canadair CL-215*. This water bomber has a box fuselage, parallel chord wings and fuselage mounted tricycle undercarriage, and it could be made to waterbomb with-



Hawker Hurricane converted from the AeroModeller free-flight by Richard Cooke of the Sudbury club. Power is provided by a PAW 19 diesel. This is one of the few WWII fighter aircraft suitable for this 'stand-off scale' approach to modelling.

out any trouble at all. For the ambitious, a simple and beautiful four engined model is the *B17 Flying Fortress*. Believe it or not, this graceful aircraft's fuselage is made up from a parallel tube back to the wing trailing edge and then a straight tapered tube aft with only a small amount of double curvature at the nose. All can be reproduced from rolled balsa sheet and very light, my 52in span version for four 1.5cc engines weighed 2½ lbs, and that was planked!

Push-pull twins have great possibilities. For example, the *Moynet Jupiter* has perfect stunt proportions with an engine at each end and a simple yet pleasing fuselage. The book *Private Aircraft* by Ken Munson has two views that could be used.

The *AeroModeller Plans Service* has two subjects that fit in with the type of model that we are talking about, they are the *Catalina* and *Fokker Southern Cross*, there may be others as good but these two models have been built in the club and have been very successful, indeed one *Catalina* is now over six years old.

Having chosen the aircraft, the next task is to scale it up. If good three views are available, then this is no problem, but often the best subjects are not obtainable in the normal plan ranges. For our purposes any three views or, in some cases just two views will do, even small recognition silhouettes. Scaling up from the last mentioned is tricky, but a good six inch steel rule and patience will give acceptable results or you can get them photographed and enlarged by any photographer, including keen amateurs.

One of the most useful and time saving pieces of equipment is a pair of proportional dividers, expensive to buy but they will repay their cost in one or two models.

It is almost impossible to specify exact sizes of model for a given engine size, for example my *Tempete* has a Fox 25R/C in it and spans

Peter Stammers displays his Fokker FVIIb3m Southern Cross, built from AeroModeller plans - a very good choice for your first multi-engined model, as the two outer engines are simply dummies with free-wheeling propellers! Plans available as order No. CL/688, price 90p including post.



36in, it has a bulky fuselage and weighs about 2½ lbs while my *Lake LA-4* has a span of 53in weighs over 3 lbs and has a similar maximum cross section fuselage. With the same power it has a higher maximum speed, but will fly almost as slowly, this being due to the efficiency of the pusher propeller and the high aspect ratio wing. By analysis of various models 75 sq in per cc of engine capacity and 20 ounces per square foot of wing area are good starting figures. For biplanes, increase the power by 50 per cent to overcome the extra drag.

The basic shape of the model is of course, governed by the prototype but within these outlines there is great scope for simplification to ease construction and alterations to improve the flying qualities, without detracting from the general appearance of the model.

It has been found that the best wing section for any model which is not intended for aerobatics is a flat bottomed section. The model will fly at far slower speeds at a lower angle of attack, which means better landings with less risk of stalling. Symmetrical and semi-symmetrical sections are not nearly as good in this respect, but the reduction in slow-speed performance for a model that is capable of aerobatics. If a WWI biplane is being

built, do not use an under-cambered section; the extra drag is just too much unless you use excessive power. The exception to this rule are pre WWI monoplanes where the undercamber does make the performance more realistic; I built a 1912 *Blackburn Monoplane* which was almost identical to the *AeroModeller* free flight design, but with no incidence and some beeing up in the nose. This was powered by one of my trusty Fox 25R/Cs and in calm weather it gave the most relaxing flying - it could be flown at less than 10mph and landed almost vertically. In this instance the undercamber was essential, but of course the model was strictly a calm weather flier.

Ailerons are not made separate items on my models, as by using paint lines they are quite realistic enough. By omitting them one saves a great deal of work and weight, but the main advantage is in the flying. Models with ailerons can develop a horizontal rocking action at high angles of attack and I believe that this is caused by an alternating tip stall which is triggered at an earlier stage by the ailerons. Models with painted ailerons can fly more slowly and at higher angles of attack before this phenomenon develops. Some people use ailerons to bank the model out of the circle, but the advantage is minor because at slow speed when they are needed most, they are at their least effective. Offset rudder and engine plus tip weight are more than enough to keep the lines tight.

Tail surfaces can be kept to scale areas in almost all cases but there are just a few aircraft that suit our purposes which need an increase. One of these is the *Cassut Racer* which is also one of the few racing planes that has real possibilities,

The Dragon Rapide and Pitts Special make interesting subjects - the author's Pitts being quite aerobatic, thanks to adequate power and light weight. Features 'working' metal cowling over the engine.

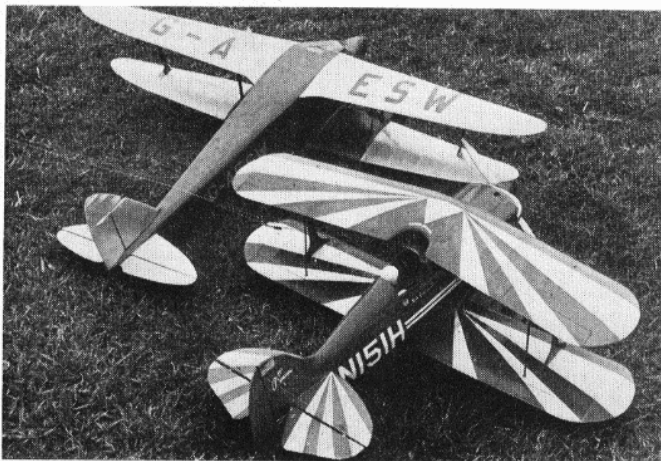



A nice slow, realistic flier is this Blackburn I912 Monoplane for Fox 25 R/C power – throttle control makes it all the more interesting in flight. The Aero Modeller free flight plan (FSP 567, price £1.15) could be adapted with hardwood spars, no wing incidence and stronger engine bearers.

being mostly fabric covered and featuring straight lines.

The centre of gravity should be as far forward as possible without risking the model nosing over on landings and take offs – 15 to 25 per cent being a suitable range. The smaller the tailplane the further forward the CG, to start with at least.

For the most part, the layout of scale models follow conventional lines but there are some interesting types of aircraft that call for some rethinking. The normal model will have its thrust line along the same line as the wing and tailplane, but with very high thrust lines (such as the *Walrus* and *Lake LA-4*) a considerable amount of upthrust is needed. In the case of these models the engine must be pointed DOWN because they are pushers. The high thrust line on the *Lake* and other similar types produces an interesting flight characteristic, when the throttle is opened or closed fast the model will pitch nose down or up respectively. One very soon becomes accustomed to this and

corrects automatically, I have recently read a report on a full size plane of this type, and the test pilot commented on this effect.

While a scale model *will* fly without throttle, I feel that it is essential, otherwise the criticism that scale models are boring to fly can become true. The *Roberts* system is very good and can save some time but I prefer the Mick Reeves system shown on pages 24/25 of this publication.

Most scale models are designed by scale enthusiasts to whom building is as much, or more, fun than flying but at the risk of offending these people I would say that many of these designs are over-complicated, over-strong and overweight. In some cases this is due to the type of model, and this is where the model selected is important. Another reason is that a certain method is the traditional way of doing the job. Now I am very lazy when it comes to building and tend to get bored with a model after about 4 weeks of construction and as a result I have developed a few of my

own methods which speed up building as an example the *Pitts Special* took four weeks to build, including one week of holiday, and has so far won the club scale contest twice plus another 'friendly' contest.

Fuselages

If the right model is chosen, the fuselage will be very similar to a stunter, but there are many variations on this theme. Where there are compound curves the normal technique is to plank the fuselage which is both time-consuming and heavy, especially when it comes to getting a good finish. Fortunately there are two ways to reduce, or eliminate, planking. One can soak soft sheet in water and clamp it to the framework with pins and elastic bands until it is dry, then glue it down. Quite complex shapes can be done this way and adding ammonia to the water helps in extreme cases. The *APS Catalina* fuselage top can be covered with two four inch wide sheets of 3/32in balsa with this method. Any really tight curves at the ends can be done by slitting the wood into strips and folding and trimming.

The second method is heavier. The fuselage sides are made from soft 1/4in sheet balsa and the rest of the fuselage is from rolled sheet or a little planking and then the sides are shaped to conform to the rest of the fuselage – the *ME110* used this system.

Stringered fuselages present no difficulty. Build a box structure from 3/16in sq. strip with sheet sides at the front to take the engine and undercarriage loads, and the fit small formers to the outside followed by the stringers and any sheet. Quick, simple and light – but it looks good – the *Pitts* and *Boeing Model 100* are examples of this method.

There are occasions when a simple

A 45in. span Boeing Model 100 built by the author for a Fox 40S R/C. Apart from the corrugated control surfaces, this model is very simple to build. Capable of loops, it also handles well on the ground – even on grass.



form of jig is an advantage. For example, the *B17 Flying Fortress* is a very simple model to build, the fuselage is circular in section and is parallel from cockpit to wing trailing edge and then a straight taper aft. This can be done with rolled sheet and a rigid jig holds everything true. In such cases buy a piece of 3 x $\frac{1}{2}$ in planed softwood from your local DIY shop – this must be a bit longer than the fuselage. Mark off the low profile and formers and cut slots for the former, then spot cement them in place and you can work on the model without worrying about crutches or internal stringers, the extra wood at the end can be held in a vice leaving both hands free.

Wings

Basically there are only two types of wing to consider; fabric covered and all sheet covered. The former are normally built in exactly the same way as a stunt wing (but with a flat bottom unless aerobatics are desired), the only difference being that the spars tend to be much nearer the leading edge. This can be an advantage as the sheeting can be pre-moulded right round the LE in the same way that we use rolled sheet on the fuselage. Trailing edges are normally narrow on the full size subject. The simplest method of making a TE, which also very conveniently represents the full size, is to use 1 x $\frac{1}{4}$ in hard sheet on the bottom surface of flat bottomed wings, or let-in on symmetrical sections. The addition of catstrips is not really worth the effort if 3/32 or soft $\frac{1}{8}$ in sheet is used for the ribs.

Sheet covered wings follow the same basic method, but of course the sheet extends all the way back, and

no separate TE member is needed, but a secondary spar at about 75 per cent chord can be a good thing.

Wings for Twins

Many people design great big, complex and very heavy spar systems for their twins and four engined models. What a waste of time, effort, wood and valuable weight! A sheet covered wing with a $\frac{1}{4}$ in square spar top and bottom webbed between the nacelles, will handle anything up to .19cu. in engines in perfect safety, and have coped with 35s. The APS *Catalina* is one such model and my own 13 lb *Canadair CL-215* is another. Both these models eventually suffered cartwheel crashes the *Catalina* wing was undamaged, and the *Canadair* suffered a repairable break. It was the rest of the damage that caused these planes to be written off! It must be admitted that these models had fuselage mounted landing gears but the *Fortress* had the same wing for four 1.5 cc motors plus the undercarriage and never showed any sign of weakness. For extra peace of mind, spruce could be used for the spars and small ply dihedral joiners may be used, though the *Fortress* had the wings butt joined with a thin layer of glass fibre mat over the join.

Some thoughts on Multi Engines

Jumping out of sequence, but following on from the previous paragraph, let's look at what must be the most impressive type of scale job – the multi-engined model. Many modelers fight shy of this type of model, and yet it need not be any harder to build than a single engined type, and certainly no harder to operate. From the construction point of view the only real difference is that two or

more nacelles have to be built, and the throttle linkages needs a couple of extra parts. Operation can be simplified by using upright engines. Yes, I can hear the screams of horror from the purists who can spend hours flicking one engine while the other one runs out of fuel! I know, I have done it too, but not any more. Remember that the point of all this is *fun and flying*.

Another point often not considered is fitting two engines and two dummy props to a four engined model. Many people may have trouble mustering four engines for a model, and anyway for reliable throttle operation one needs at least a 2.5cc engine – four of which would mean a big model for the average car to transport. The answer is of course two and two freewheeling dummy props.

Tail Surfaces

Unless you are one of those modellers who never use one piece of wood when ten will do, sheet balsa tail surfaces are the answer; $\frac{1}{4}$ or $\frac{3}{8}$ in sheet will suit most models, and this can be hollowed out to save weight if necessary. There are a few aircraft which have such thick surfaces that ribs and $\frac{1}{8}$ in sheet covering is essential, and sometimes it may be necessary to build up the surfaces to save weight, i.e., when the aircraft has a short nose combined with long tail moments. With aircraft featuring twin fins, spruce spars will save a broken tailplane in the event of a nose over, for the same reason easily detached fins would pay dividends. A designed-in break point will save damage and probably a wasted flying session.

(continued on page 67)

Natural progression for the control line flier to scale modelling is shown in this Suffolk Free Press photograph, illustrating a stunt model, semi-scale stunt design and a full multi-engined Boeing Fortress. Incidentally, the Fortress is the lightest of the trio – which shows what you can do with careful design and construction.

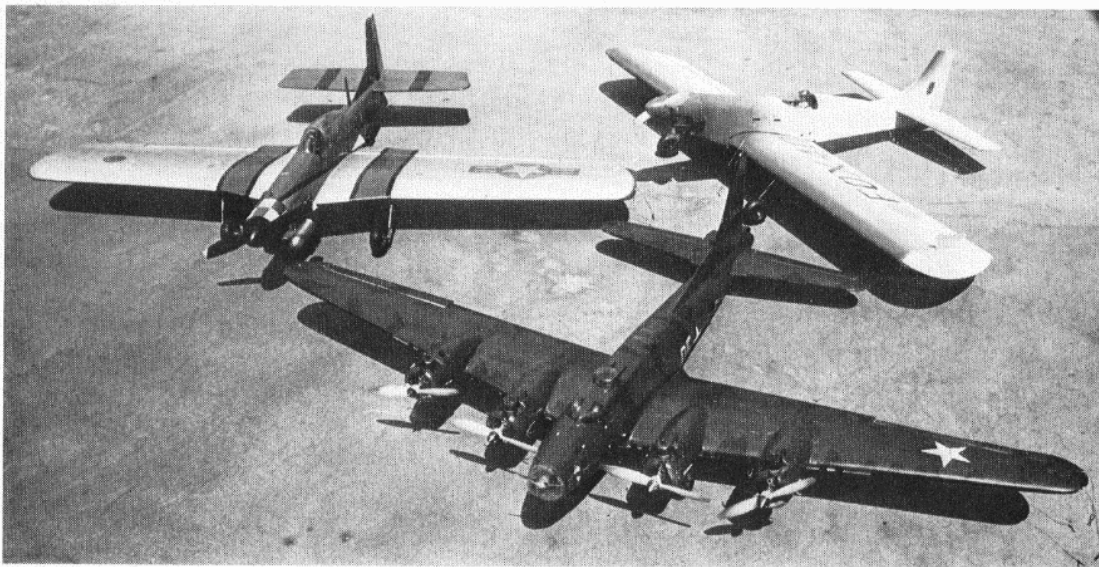

A LITTLE PIECE OF HISTORY

BY JURGEN LENZEN

In this modern competitive period of very sophisticated FAI class team racers, with high powered Bugl or Rossi diesel engines fitted into mono-wheeled 'minimum' models, it is interesting to recall the early days of International class racing. This model described by Jurgen Lenzen of West Germany (who incidentally still flies team racers as well as speed) was probably the first design to break away from traditional materials and employ all-metal construction

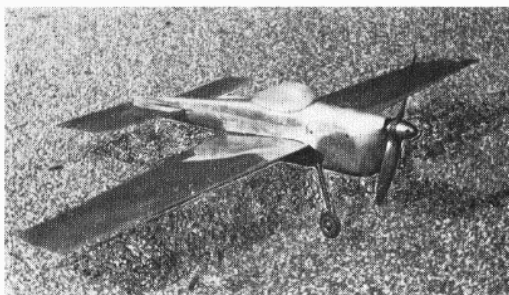

Silver Arrow was designed in 1956/57 with the construction being influenced by the German team racer 'IXTL' by Dr Helmut Ziegler. This 'IXTL' had the advantage of a detachable wing and was one of the last racers built to the 8dcm² wing area rules. It featured a wing shaped from 8mm thick balsa sheet and a fuselage built around a limewood crutch with balsa formers and cardboard skin construction, plus a metal 90° V-tail. The main disadvantage was that oil soaked through to the wooden crutch even when carefully painted. This last point was the reason for developing an all-metal model, where there was no wood able to rot! Basis for the new form of construction used for Silver Arrow was a cast aluminium fuselage full length crutch. The material was an aluminium-silicon alloy which was very easy to saw and drill. Everything needed to complete the model was screwed to this crutch, beginning with the engine. Just behind the engine, there was the 10cc tank (20 x 30 x 16mm) with a filler vent, a feed pipe and an overflow pipe.

The filler vent was mounted to allow for an easy filling procedure

and to prevent fuel from siphoning out during flight. The overflow pipe was directed forwards to give a little pressure in the tank. The tank was filled with a 125ccm plastic bottle with brass spout to open the tank vent – much like a Rat Race Quick-Fill of today. The tank was mounted on the top of the crutch to provide gravity for easy restarting. The first flick starts of my engine was one of the secrets of the very good times which were achieved.

The first engine used was an Oliver Tiger Mk I and later I obtained a modified Oliver Tiger Mk III. At this time it was very difficult to get an Oliver engine because the German enthusiasts, who had one of these engines, would not reveal the address of J. A. Oliver! Oliver engines were the best because one could obtain a range of 35 laps with them and no other engine could match this. At this time, in Germany, one could buy the Webra Mach I and the Taifun Rasant or the Taifun Tornado engines, but with these engines one could only fly for 20 or 25 laps per tank.

Back to Silver Arrow construction. Just under the tank, the two wheel undercarriage was screwed to the crutch and behind the tank there was a fuselage former, but only on the top of the crutch. The former was made from an 0.8 x 10mm strip of hard aluminium to give the shape for the top fuselage skin. Behind the fuselage former there were two long screws screwed through the frame for mounting the wing and the bellcrank (see accompanying drawing). The bellcrank was mounted to the front screw just under the frame. Between the frame and the bellcrank there was a nut and a washer, then the bellcrank, a washer and two nuts and this was the fixing point for mounting the wing. The second screw was only used for mounting the wing.

At the rear of crutch, the tailplane was bolted in place together with the rear skid, which was mounted underneath using the same screws. The tail was made from a piece of 0.8mm Elektron or dural which was from an old Stuka Ju 87. I obtained the material from Mr Gottlob Espenlaub (a very famous name in Germany. Mr Espenlaub was amongst the first people to start sailplane gliding in the RHON, Wasserkuppe, together with Alexander Lippisch in 1920. During World War II he repaired Stukas in Wuppertal in his own factory). The model's elevator was only on the left hand side of the tailplane. This of course was the wrong side, but the model was one of my first designs, and was influenced by a V-tail model, where the elevator was on the correct side. However I never had any problems with this "wrongly mounted" elevator all the time I used the model! The fuselage skin was made from 0.18mm half hard aluminium

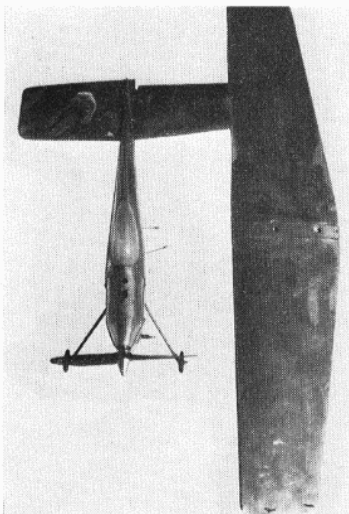

SILVER ARROW

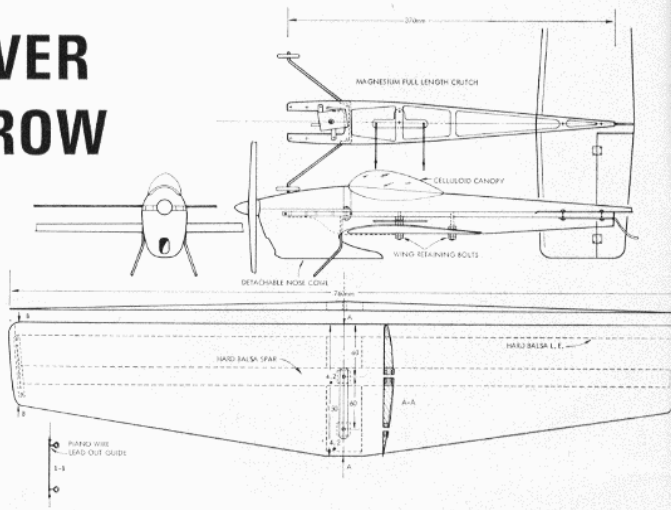

CONTROL LINE

Shown here are the main fuselage components, with an early Oliver Tiger diesel bolted to the full length crutch and with the detachable hand beaten sheet metal nose cowl and top fairing. Bracket at top was used to retain the wing – being bolted to the underside of the crutch and bottom of the bellcrank pivot.

except for the engine cowling which was made from a piece of 99.9% Alu-tin, 1.5mm thick. This was hammered around a cast metal form block. I had three different cowling shapes – the pictures show the latest version. The formed cowling was filed and sanded after shaping and then a polished finish was achieved with rotary polishing tools. The canopy was glued to the top skin of the rear fuselage.

The most interesting part of the model was the wing which featured two hard balsa spars – one at the leading edge and one in the middle, and which extended over nearly the full span inside the wing. In the centre of the wing (where it was screwed to the fuselage) there was a wing former.

Plywood reinforcement was glued around the mounting holes for greater strength. The wing was skinned with 0.18mm half-hard aluminium material – the underside of the wing was flat and the wing's profile tapered from 10mm thick in the middle down to zero at the tips while the nose radius similarly changed from 3mm in the middle to zero at the tips. To build the wing, first you had to make the spars and former and the front spar needed the exact nose radius, because the aluminium was bent around this. The wing was bent from a single sheet of aluminium. To make the wing, the aluminium was laid on a table with the leading edge at the edge of the table. Then the spars were glued in place and the wing bent around the leading edge. Then the upper and lower skins were bonded together at the trailing edge. Finally the lead-out guide was made from 1mm steel wire. This was made up without the 'eyes' being formed, then two holes were drilled through the wing in the correct position, and the guides' ends pulled through and glued in place with a 0.2mm strip of tin underneath the wing. Then the eyes were bent and the whole secured with two small rivets.

The wing, as a hollow body, was very stiff and not too heavy. The weight of the complete model was approx 580gr – very good for the time it was developed. A lot of balsa models of this period weighed more than 600gr. Also, remember that the model had a

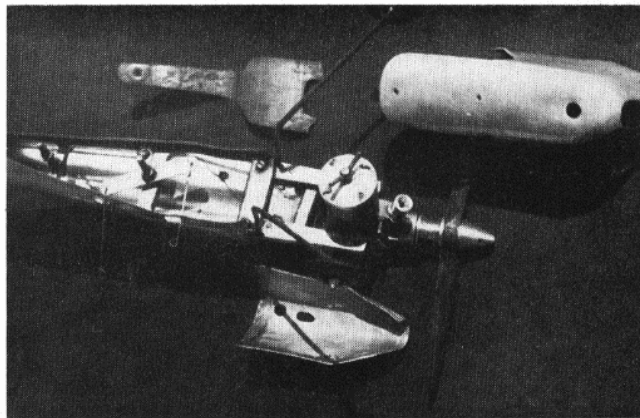

two wheel undercarriage, with 3mm steel wire legs and very heavy wheels so the weight of 580gr was not bad. The model won the 1957 German Nationals (Lenzen/Eicker) and placed fourth at the 1957 European Champs in Barcelona held at the well-known "Montjuich" hill.

During the European Champs the Spanish spectators had a very interesting spectacle – they could see the model winning a heat race in which the prop broke during a pit stop; the time for the stop was only 18 seconds including changing the prop!

Three *Silver Arrows* were built at this time, and two are still "alive"! One model I have myself in full flying trim with its original Oliver Tiger engine and 7 x 8in *Power prop* propeller with which it was last flown. A second version I presented to Jurgen Bartels as he is collecting propellers, engines and famous old models."

FLY-FOR-FUN SCALE

continued from page 65

Undercarriages

There is no need to build fancy undercarriage legs, good old piano wire will do the job perfectly, but make sure that it is not too springy as this can cause nose-overs. 10 swg is recommended as the standard size, but use

A 'different' subject by Ken Gardner is this *Tiger Moth DH71* monoplane – built from an R/C kit, and powered by a *Fox 40S*. Covering is with gold *Solar film* – looks most attractive.



8swg for nose legs, or you will be forever bending it back into position. Tricycle geared models will often tip over on take off or while taxiing, especially on grass. One answer would be a castoring nose wheel, but this is heavy and complicated. The simple answer is to walk with the model on take-off, so relieving the drag on the lines.

Finishing

Everyone has their own favourite method of finishing. Most scale models have superb finishes, either highly polished or painstakingly weathered. Very nice if that is what you like. Go ahead but *keep it light*

and remember that the model is for fun flying, and may be flown from all types of field. It may be landed a bit too hard or nose over on grass, or be stalled through trying to see just how slowly it can be flown, all of which is detrimental to good finishes. For painting I use nothing but *Duplicolor* car aerosol sprays. They save time and weight, and will match almost any colour used on full size aircraft.

Details

While details add considerably to the appearance of the model, external ones get knocked off and internal ones cannot be seen in flight. I usually have a scraper board instrument panel, a seat and a pilot if I can find one the right size while exterior detail normally consists of prominent features like pitot heads and, in the case of the *Tempete*, the wing fences. The pitot head on the *Tempete* is from a cycle brake cable outer. It can be bent in a U shape and still spring back; this principle could be applied to aerals etc.

Conclusion

From all this it can be seen that one can have a reasonable scale model for little more effort than a stunter. When you have built your scale job why not take it to the *AeroModeller Scale Rally* at Old Warden? You may not win a prize, but you will have one of the better flying models.

CLASSIC CLARKSON "QUICKIES"

A ROUND-UP OF USEFUL TIPS BY AEROMODELLER'S COLUMNIST

On burying leadouts . . .

Burying leadouts in solid balsa wings is essential for FAI team racers and highly desirable for Goodyears, and yet it is one of those jobs that can be difficult, and frequently the results look bad – especially with the currently fashionable thin wings. The method described and illustrated in *Figure 1* is quick and easy, and the resulting job looks really great.

Firstly, cut a hole in the unfinished wing for the bellcrank, then cut through the wing from bellcrank hole to tip $\frac{1}{16}$ in outside the intended leadout track. Remove this 'wedge' of wood. Now carefully groove the edges of the removed wedge along their centre lines, using a ball point pen. Enlarge and deepen these grooves with a piece of glasspaper wrapped around a piece of $\frac{1}{16}$ in. ply.

Epoxy $\frac{1}{16}$ in. lengths of 14 swg brass tube into the ends of the grooves and when set glue the wedge back into position in the wing. Now the wing can be shaped and finish-sanded, and all one can see of the finished job are two very faint joint lines.

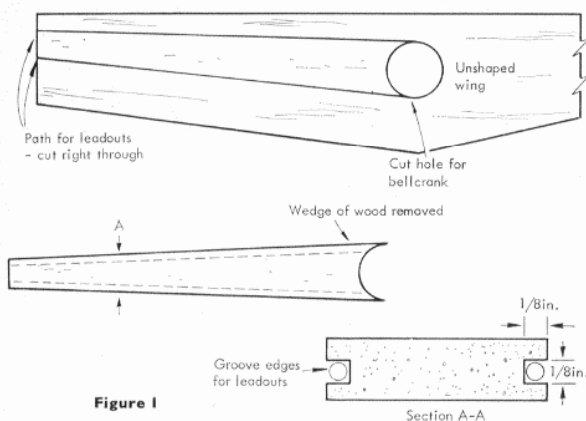

Figure 1

On bent wire horns . . .

Elevator horns bent out of 18 or 20 swg piano wire are very quick to make and are surprisingly strong and easy to install. The basic requirement is for a loop in the middle of the piece of wire and this is formed in a few seconds on a simple jig as shown in *Figure 2*.

All that is necessary is to form a 90° bend into the wire, insert this end into the $\frac{1}{16}$ in diameter hole and holding the wire with the finger tips down on to the board and against the peg, wind the wire quickly and tightly around the peg.

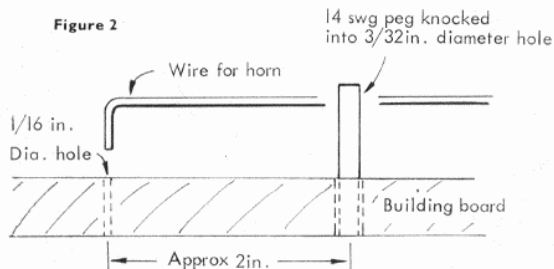
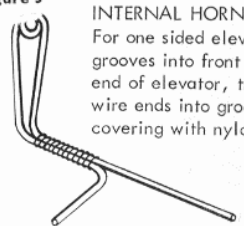

Figure 2

With the loop in the wire we can now make other types of elevator (or flap) horns as shown in *Figures 3 and 4*.

I have used such horns bent out of 20 swg piano wire for combat models, Goodyears, FAI and 'B' team racers with no signs of bending or distortion in use. For big stunters I would recommend that 18 swg wire is used because of the bigger throws and distances involved.

Figure 3



INTERNAL HORN
For one sided elevator. Sand grooves into front and inboard end of elevator, then epoxy wire ends into grooves, covering with nylon patch.

Bind with fuse wire and solder



EXTERNAL HORN
Sew and epoxy to elevator.

Figure 4

On a team-race style handle . . .

One of the pilot-conduct rules for FAI Team Racing that is strictly enforced is the 'handle on the chest' rule, and I for one have been severely troubled by this requirement. With a conventional handle, where the leadouts emerge along the major axis of the grip, if the handle is to be securely gripped and one's hand, as opposed to one's wrist, is to be held onto one's chest, then the leadouts lie parallel to the chest and therefore at 90° to the lines. For those of us with weak wrists, this 90° angle between the lines and the handle leadouts, tends to lever the hand off the chest, and undesirable and unwanted warnings result. To ease matters, I made a simple handle with the leadouts angled the full 90° to the grip. Subsequent experience with this handle has shown that it helps a great deal to solve my 'hand-off-the-chest' problem.

Figure 5 shows that this T/R handle is constructed using a suitable piece of wood (preferably hardwood – mine came from an old chair) and a short length of Bowden cable from a bicycle shop. The handle is adjusted for neutral elevator by slackening the clamping screw, sliding the Bowden cable appropriately, and then re-clamping the cable. My clamping screw is a 2BA mushroom headed screw of suitable length, with the nut slightly filed on the flats to enable a normal plug spanner to fit (if you forget yours someone on the field will always have a plug spanner).

The sketch shows a '2 finger' handle intended for use by a right-handed pilot. The '2-finger' leadout spacing (i.e. the leadouts emerge from the grip between your 1st and 2nd and 3rd and little fingers) is the one used by the vast majority of T/R pilots.

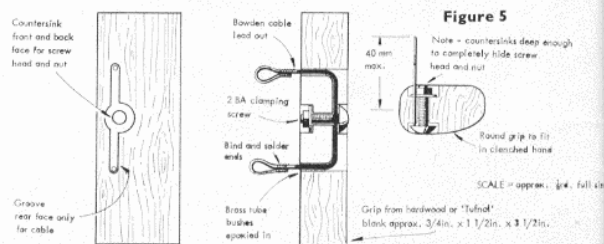

Figure 5

SCALE = approx. 1/4 in. full on

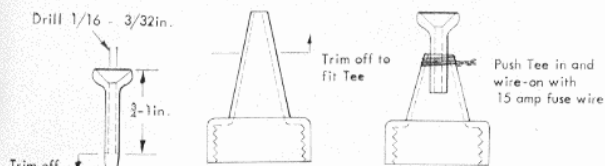

Figure 6

On golf tees for squash bottles . . .

Picked this up from Tony Harknett in London, way back in 1970 – I don't know if Tony invented it; however, he was the first one I saw using this idea. The problem with squash bottles when trying to fill a fuel tank fast is that of getting its nozzle connected to the tank. If you modify your squash bottle to take a drilled-out golf tee, as in *Figure 6* you will find fast tank-filling much easier. The conical inside shape of the golf tee guides the bottle on to the tank filler tube, and also acts as a sort of taper seal between bottle and tank, to stop too much fuel escaping whilst the tank is being filled.

There are quite a few types of golf tee. Reject wooden and polystyrene (brittle plastic) tees as these are no good for us. Try instead to find the biggest possible nylon or polypropylene (flexible plastic) tees. If you are using a plastic-spouted squash bottle (e.g. hand cream container, etc.) then all that is needed is to cut the tee down to $\frac{3}{4}$ in-1 length, drill it $\frac{1}{16}$ in – $\frac{3}{32}$ in down its axis, trim the bottle spout until the tee pushes in and finally wire the tee firmly into the spout. Other types of bottle may be used, such as washing-up liquid bottles, and alternative mounting methods are easily worked out.

On glass covered models . . .

Almost by coincidence at a recent NORWEST club meeting we had Heaton/Ross, Sutherland/Woodside and Clarkson/Daly all producing either glass-cloth covered wings, or in one case a completely glass-cloth covered model and each telling the other how incredibly easy it had turned out to be! Those in the past who have wrestled with polyester resin, that does not seem to want to 'go off' fully in thin films, or tried to get hold of epoxy resins that do not have the consistency of treacle, will probably not agree that glassing models, especially fuselages, could ever be incredibly easy. But all of us agreed that using the technique described here was much easier and quicker than 'dope and tissue' finishing methods, and the results were possibly lighter and certainly gave a much stronger, more rigid model. Quite a breakthrough seems to have happened.

The essentials of this new technique for glassing models are as follows:

1. Before covering, sand down the item to be covered using fine glass paper to give smooth, ridge and dent-free surfaces. Remove all dust etc.
2. Lay suitable glass-cloth over the bare, sanded balsa and brush on epoxy paint. Allow to cure and then give the surface a gentle sanding. Finally apply one more coat of epoxy paint.

That's it folks! The finish quality can be improved, if desired, by applying further coats of epoxy paint rubbing down gently between each to give a mirror finish, but all you do by this is add unnecessary weight.

So far we have tried K & B Super Pox paint using the brushing catalyst supplied, and Humbrol Epoxycote paint with equally satisfactory results. The K & B paint has the advantage that a clear (and very thin) variety is available for those who like clear finishes, and also this brand seems to cure to a greater hardness than the Humbrol product. Humbrol Epoxycote paint has the advantage

that it is (relatively) cheap, and is available from most retail outlets. Both paints seem to handle exactly as the instructions say i.e. they cure to touch dryness in about 4-6 hours and fully cure to a 'flyable' state in 2-3 days. Pot life seems good at around 1-2 hours before the paint starts thickening and becomes a little more difficult to use.

My phrase 'suitable glass cloth' applies to untreated (in trade terms 'loom-state') glass cloth with a weight in the range $\frac{1}{2}$ to $1\frac{1}{2}$ oz per square yard. Sources for such cloths are given on page 70 of this publication, however suitable glass cloth is becoming available through normal retail outlets. In my part of the country many model shops are now stocking rather superb quality 0.6 oz per square yard cloth of British origin. This particular cloth goes over compound curves effortlessly – I did a complete fuselage using just two pieces (could have done it with one piece if the wing and tail had not been there). In this respect it seems slightly superior to the nationally available imported glass cloth of $\frac{3}{4}$ oz per square yard weight.

On the 'Hot Thumb' . . .

First seen in use by John Dixon in 1970 (who was, at that time, beating everyone out of sight in Goodyear) is the 'Hot Thumb'. Now copied by many who want to supply sparks to their glow motors quickly and conveniently – still mostly 'Goodyear' men – this little device is deserving of space in all glow-users' model boxes; *Figure 7* shows construction – dimensions given are approximate and can vary, depending upon the size of your motor (and, of course, your thumb).

Operation of this device is quite simple and is, in fact, completely 'automatic' on side-mounted engines, in that when you grip the model around the motor, the centre terminal of the glow plug goes into the $\frac{1}{4}$ in diameter hole through the insulant and therefore contacts the thumb grip, and when you straighten your thumb the cylinder head touches the top contact, completing the circuit and giving the glow! For convenience, the accumulator (anti-spill types only) should be strapped to your forearm, thus allowing very short leads for a good hot 'glow'. The ultimate sophistication which allows direct observation of your plug condition – such as no current (blown plug), low current (dry motor), or high current (wet motor) – is to mount a 0-5 amp ammeter in the circuit and this is conveniently done, depending upon the type of ammeter, by making a metal strap that connects one of the ammeter terminals to one accumulator terminal. The hot thumb leads are then connected to the free accumulator terminal and the free ammeter terminal. With a bit of cunning bending of the ammeter strap, the ammeter dial can be arranged to fall within your 'starting position' range of vision – no having to glance away from the motor to see the amps.

Whilst this set-up is of particular use for Goodyear men, it is also very applicable to pitmen for Combat and 'B' Team Race.

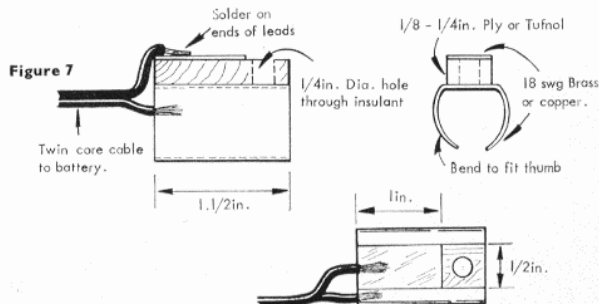

Figure 7

THE SPECIALISTS

CAUTION! The items and suppliers listed below are singled out because they have certain items not normally available from model shops. Bear in mind that the majority of suppliers are purely enthusiasts who produce items in their spare time, and not on a truly commercial basis. Therefore, supplies of goods may be erratic, and there can be long delays in delivery of goods. It is advised that before sending cash you enquire exactly as to the availability of items, and send a self addressed envelope (or International reply coupon) for reply. Equally, we cannot endorse the quality of the items listed. Where normal trade suppliers are mentioned, the items may be available from model shops on special order.

Team Race Accessories

- (a) *North West Model Supplies* (579 Rooley Moor Road, Rochdale, Lancashire). Fuel shut-offs, circular bellcranks, filler valves, wheels, Howard glass fibre props, Rossi carburettor insulator, venturis, Rossi extension prop driver and sleeve nut.
 - (b) *Irvine Engines* (via model shops or details from Unit 8, Alston Works, Alston Road, High Barnet, Herts.). Crutches, pans, Don's Quickfills.
 - (c) *DES Model Components* (7, Pendle Close, Basildon, Essex SS14 3NA). Glass fibre props by Bartels, Tribe Brothers.
 - (d) *H. J. Nicholls & Son Ltd.*, (308 Holloway Road, London N.7). Bartels G. F. propellers, crutches.
 - (e) *Rolf Orell* (Norrtullsgatan 9, 13329 Stockholm, Sweden). Two part copper contra piston for Rossi 15 diesel, FAI wheel.
 - (f) *Emil Rumpel* (Vornholzes Ring 32, 5810 Witten 3. West Germany). Rossi T/R pieces, including Allen-head comp screws, Cox style collector ring carbs and venturis, plastic inserts, circular bellcranks, magnesium pans.
 - (g) *Foam Foil* (37 Slead Avenue, Brighouse, West Yorks NS6 2JE). Aluminium sheet for skinning balsa cores, also 3M Fast Bond contact adhesive.
 - (h) *Paul Schippers* (Postbus 1355 5 Hertogenbosch, Holland). Pans, canopies, bellcranks, wheels, pilots, tank valves, GF fuselages, finger valves, Cox type carbs, two part contra-pistons, venturis, nylon backplates, pressure re-fuelling kits, drum valves.
 - (i) *Derek Heaton* (4 Carpenter Grove, Podgate, Warrington, Lancs.). 3/4A, FAI and 'B' pans and crutches.
 - (k) *Graham Howard* (2, Fairacres Road, High Lane, Stockport, Cheshire). Glass fibre props.
 - (l) *Jurgen Bartels* (Postf. 3001-D2900, Oldenburg, West Germany) Carbon and Glass fibre propellers.
 - (m) *Flemming Jensen* (26 Centerparken, DK 2500 Valby, Denmark) Glass fibre props.
 - (n) *Jago Competition Equipment* (136 London Road, Kingston, Surrey). Glass fibre propellers.
- ## Speed Accessories
- (a) *Irvine Engines* (via model shops or details from Unit 8, Alston Works, Alston Road, High Barnet, Herts.). OPS speed pans/glass fibre fuselages, Uniline control handle, H & R monoline units (when available).
 - (b) *Maple Models* (16, Maple Road, Luton, Beds. LU4 8AE). Glass fibre FAI fuselage.
 - (c) *Emil Rumpel* (Vornholzes Ring 42 5810 Witten 3. West Germany). Centrifugal force fuel switch, circular bellcranks, tanks, magnesium pans, metal skinned wings and tails.
- ## Combat
- (a) *North West Model Supplies* (579 Rooley Moor Road, Rochdale Lanes). 100ml syringe.
 - (b) *Michaels Models* (646-648 High Road, N. Finchley, London N12 0NL). 100ml syringes, pacifiers, combat kits.
 - (c) *Wonderwings* (3, Rack End, Standlake, Oxon). Kits, pacifiers, plans.
 - (d) *George Mattei* (105, Franklin Road, Hamden, CT. 06517, USA). 7 fluid ounce syringe for pacifiers.
- ## Special Engines/Services
- (a) *Paul Bugl* (8051 Pruppach, AM Burgstall 17, West Germany). Bugl 15 Team race diesel.
 - (b) *Nelson Competition Engines* (729 Valemont Drive, Verona PA 15147 USA). Nelson 15 team race diesel.
 - (c) *Model Parts Inc.*, (1015, S. 61st St., Minneapolis. Minn. 55415 USA). TWA engines for speed, 'B' combat, Profile Carrier, etc. Also heavy duty con-rods, crankshafts, ABC piston/liner sets for certain high performance engines.

- (d) *Allan Cooper* ("Hillcrest", Top Road, Hardwick Wood, Winjerworth, Chesterfield, Derbyshire S42 6RQ). Specialist machining work.
- (e) *J. R. Feeney* (81, Sandacre Road, Baguley, Manchester 24). Specialist machining, including turning, milling, drilling, honing.
- (f) *Brian Fairey* (242, Bellhaven Drive, Waterloo, Ontario, Canada N2J 4L6). RAM engine castings, crankcase, head and backplate.
- (g) *Maple Models* (16, Maple Road, Luton LU4 8AE). Standard glow plug conversion for Rossi and Super Tigre engines, Specialist work to order, re-bores, safety nuts, vintage engine spares (as available).
- (h) *Luis Petersen* (Kirkegardsvej 10, 2300 S, Denmark) Bugl engine repairs.
- (i) *Kustom Kraftmanship* (P.O. Box 2699 Laguna Hills, California 92653 USA). Custom tuned Cox, Rossi and Super Tigre engines. Special Cox -049 parts fine thread needle, con-rod re-seating tool.
- (k) *Fox Manufacturing Co.* (53-55 Towson, Fort Smith, AR. 72901 USA). Items not usually available via Fox stockists. Fox 29 Combat Special engine, Modified Fox 30BB, Stunt 45 with hardened cylinder and piston (available separately), Fox 19 with modified cylinder (available separately) glow plug taps, tuned pipe.

General C/L Accessories

- (a) *North West Model Supplies* (579, Rooley Moor Road, Rochdale, Lancs.). Lightweight glass cloth, eyelets for control lines.
- (b) *H. J. Nicholls & Son Ltd.*, (308, Holloway Road, London N7). Roberts 3-line control system, U-Reely handle/internal line storage, pitch gauge.
- (c) *Micro Mold* (via model shops or details from 1-2 Unifax Woods Way, Goring by Sea, Sussex). Technicraft propeller pitch analyser.
- (d) *Emil Rumpel* (Vornholzes Ring 32, 5810 Witten 3. West Germany). Pitch gauge.
- (e) *Viking Models* (113, Liscombe, Birch Hill, Bracknell, Berks.). Lightweight glass fibre cloth, carbon fibre.
- (f) *Irvine Engines* (via model shops or details from Unit 8, Alston Works, Alston Road, High Barnet, Herts.). Lightweight glass fibre cloth.
- (g) *Wonderwings* (3, Rock End, Standlake, Oxon). Nichrome wire for cutting polystyrene foam blocks.
- (h) *Model Flight Accessories* (via model shops or details from The Mill, Mill Lane, Worth, Deal, Kent). Foam wing cutter and transformer, ni-chrome wire.
- (j) *Jago Competition Equipment* (136 London Road, Kingston, Surrey). Magnesium plate and bar, special 2-part epoxy resin for use with lightweight glass fibre cloth (also supplied), three strand control-line wire - 1000 metres.

Control Line Newsletters/Organisations

- Control Line Aircraft Racing Association (CLARA)*
Subscription rate £2 per annum. Details G. D. Bryant, 31 Woodridge, Birchfield, Birmingham B6 6LN.
- Control Line Aerobatic Pilots Association (CLAPA)*
Subscription rate £1-80 per annum. Details J. Mannall, 27 Kestrel Road, Bedford.
- Missing Link*
Subscription rate 5 Guilders per annum. Details from Ron Kaptijn, Schoonboomstraat 391, Amsterdam, 1018, Holland.
- FAI Control Line Society (FAICLS)*
Subscription rate (U.S.) \$5-00 per annum. Details Laird Jackson, 523 Meadowbrook Circle, St. Davids, Pennsylvania 19087, USA.
- CL Racing Pilots & Mechanics Association (CL-RPM)*
Subscription rate (US) \$7-00 per annum. Details c/o Russ Sandusky, 1122 Plaza Circle, Joppa, MD 21085, USA.
- Miniature Aircraft Combat Association (MACA)*
Subscription rate (US) \$6-00 per annum. Details Patty Sak, Treasurer, 309 South Kansas, Edwardsville, IL 62025, USA.
- Precision Aerobatics Pilots Association (PAMPA)*
Subscription rate (US) \$6-00 per annum. Details Wynn Paul 1640 Maywick Drive, Lexington, Ky. 40504, USA.
- Hi-low Landings (Navy Carrier)*
Subscription rate (US) \$5.00 per annum. Details Ted Krave 1212 E. Manhattan Drive, Tempe, Az 85282, USA.

TORBAY . . . *A section of our specialist model shop*

A huge variety of KITS ENGINES, RADIO CONTROL UNITS MATERIALS and ACCESSORIES including:

RipMax — Keil Kraft — Davies Charlton — Enya — O.S. — Solarbo — Futaba — Fox — Mercury — P.A.W. — MacGregor — Micro Mold — Humbrol — Veron — Harry Butler — Sanwa — Mansel's/J.P. (The really effective add-on Muffler) — Airfix — Revell — Tamiya and lots and lots more for all Aeromodellers !

MANSEL'S models

Established 1960

**Mansel's Corner,
Palace Avenue, Paignton, Devon
Tel. 0803 - 521767**

If you cannot call to see us we welcome your MAIL ORDERS — WORLDWIDE!
Access, Barclaycard, Visa, Hobbycard or Any Currency accepted with pleasure.
*Phone anytime, anyday — our recording machine will take your order for priority attention when we reopen!



FOAM FOR ALL

continued from page 11

COVERING POLYSTYRENE WINGS

First, sand the foam smooth — for a super smooth contest stunt model type finish, use very fine garnet paper wrapped around a block of scrap foam. The best covering material is gift wrap paper, as this gives a pre-decorated surface and is very strong when applied with wall paper paste. If you wish for a conventional paint job, then use a thin smooth finish paper equal in quality and weight to gift wrap paper. The paper/paste/foam bond is very strong and is a highly recommended form of covering. Brown wrapping paper can also be used but it is rather heavy. Suitable pastes are *Polycell Heavy Duty* or *Polycell Plus*, diluted in the proportion of two heaped teaspoonfuls per $\frac{1}{2}$ pint of water.

Method

Cut the paper to give a $\frac{3}{4}$ in overflap all round the wing. Using a 2in or 3in paint brush, paste the wing. Soak the paper in water, dry it in a bath towel — while still damp, plonk it onto the model. Exclude all air bubbles by brushing the paper with the brush or with the edge of your hand, working from the spar to the leading edge and trailing edge. Wrap it round the LE and TE. Turn the model over, place blocks under each tip to keep the sticky wing clear of the work bench, repeat the above operation for the under surface of the wing. You end up with a double layer of paper at the LE and TE which adds a lot of strength. The model will be extremely heavy, but will get lighter again when the paste dries out. The warmer the room the, quicker it dries. You can use a fan heater to reduce drying time, but you must turn the model every 5–10 minutes, otherwise a large warp may result if one side dries out before the other. Do not get the model too hot or the plastic will melt and/or air bubbles will appear under the covering.

After covering, leave for 12–24 hours and then give two coats of Ronseal polyurethane wood varnish to get a high gloss finish, if using gift wrap. If you chose plain paper, it can be decorated with any form of paint and then follow with the Polyurethane, preferably sanding down between coats.

PLASTIC FILM COVERING

Remember, you can apply plastic film covering (such as Humbrol *Flitespan* or *Solarfilm* etc.) over paper, but not paper over film. However, whilst quicker to apply, it does

AEROMODELLER

JURGEN BARTELS

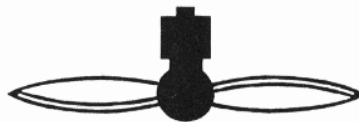

Bartels - Glasfiber - Propeller

**MANUFACTURERS OF
GLASS FIBRE PROPELLERS
FOR 14 YEARS . . .
. . . AND STILL GOING
STRONG**

Postf. 3001-D2900 Oldenburg
West Germany
0441-53-906

not form such a strong bond with the foam as the above method, so the resulting structure will not be as strong. If you intend to use the model in combat, add a gummed paper strip or some draughting tape along the leading edge before covering, to prevent streamer strings cutting the wing. Do not cover the model until the white glue has dried, otherwise the glue which will be surrounded by air-tight plastic, will take ages to dry out. Cover the model using one piece for the top wing surface and one for the bottom. You may find it easier to cover the tips separately. Tack the film all round the edges, then shrink with a heat gun or with an iron held very close to the covering. Or, cut the film into 6in wide strips, and starting at the trailing edge, iron a strip on, wrapping it round the LE and back over the TE. Add the strips starting at the outboard tip and work inwards to minimise the chance of fuel and oil seeping under the joints.

FOX

VALUE FOR MONEY RANGE OF MOTORS FOR CONTROL LINE

- FOX 15 SINGLE BY PASS
- FOX 15 SCHNUERLE P.B.
- FOX 15 SCHNUERLE 2 B.B.
- FOX 19 SINGLE BY PASS
- FOX 25 SINGLE BY PASS
- FOX 29 SINGLE BY PASS
- FOX 35 STUNT
- FOX 36 SINGLE BY PASS P.B.
- FOX 36 B.B. COMBAT SPECIAL
- FOX 40 SCHNUERLE P.B.
- FOX 40 SCHNUERLE B.B.
- FOX 45 SCHNUERLE P.B.
- FOX 45 SCHNUERLE B.B.

Fox products are available from all good model shops.

Second to none after sales service

JOHN D. HAYTREE, FOX MANUFACTURING CO. (U.K.),
SHUTTERTON INDUSTRIAL ESTATE,
DAWLISH, DEVON EX7 0NH.
TELEPHONE: (0626) 864564



FLY IT

IN YOUR BACK GARDEN WITH AN ELECTRIC R.T.P. SYSTEM

25p in stamps brings an illustrated catalogue of specialised equipment and the name of your nearest stockist.



HARRY BUTLER (Models)

Unit 13, Brunel Road, Gorse Lane Ind. Estate, Clacton, Essex
 Telephone: Clacton (0255) 29190

Control line
 model **DESIGNS**
 Hundreds of proven
 designs to choose from

AEROMODELLER PLANS SERVICE



**PLANS
 HANDBOOK No1**
 Fully illustrated,
 Price 30p



MODEL & ALLIED PUBLICATIONS LIMITED
 Sales Office: P.O. Box 35, Bridge St., Hemel Hempstead,
 Herts HP1 1EE Tel: Hemel Hempstead 2501-2-3 (Mon. to Fri.)

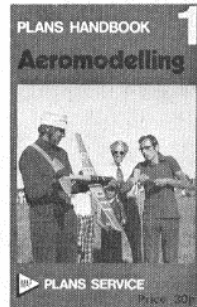

KINDLY MENTION 'AEROMODELLER' WHEN REPLYING TO ADVERTISEMENTS

IRELAND

Skyleader R/C System

Large selection of kits by MK, Veron, M.F.A., Kamco, Ripmax, True-Line, Keil Kraft, etc.

O.S. ENGINES

Accessories by Kavan, M.F.A., Micro-Mold, SLEC, Ripmax, PB, Goldberg, Taylor, MK, TopFlite.

SOLARFILM - EPOXY - DOPES

See the selection at:

W. J. OWENS

41 MAIN STREET, BRAY

(Phone: Dublin 863664)

WE HAVE BEEN SERVING CONTROL-LINE FLIERS SINCE C/L FLYING BEGAN IN 1946 AND STILL CARRY STOCKS OF ALL CONTROL-LINE KITS, ENGINES AND ACCESSORIES.

Two of our exclusive lines are

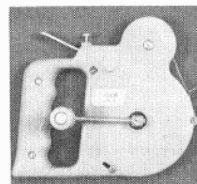

U-REELY HANDLE WITH 100 FT STRANDED LINES BRAKE AND POSITIVE STOP. Price: £9.65 (P&P 55p)

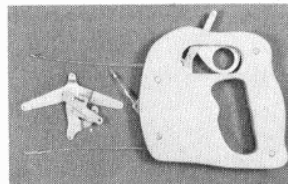

ROBERTS 3-LINE CONTROL HANDLE FOR ELEVATOR & ENGINE CONTROL £5.75 (p&p 45p)
ROBERTS BELLCRANKS £2.95 (p&p 25p)

HENRY J. NICHOLLS & SON LTD.,
308, HOLLOWAY ROAD, LONDON, N7 6NP.
Telephone orders by Access & Barclaycard
01-607 4272.

FUEL TANKS from RIPMAX

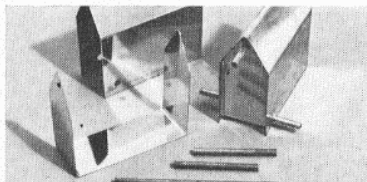

RIPMAX SOLDERTITE C/L TANKS

High quality C/L stunt tanks in tinplate with soldered seams. Also in KIT form. Small Stunt Wedge Lowline 42p. Kit 24p. Medium Stunt Wedge Lowline 50p. Kit 30p. Large Stunt Wedge Lowline 55p. Kit 35p. Extra Large Stunt Wedge Tank with Baffle, complete £1.10. In kit form 50p.

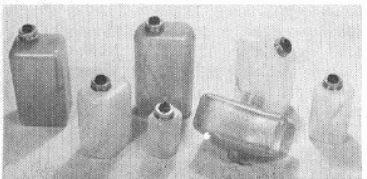

RIPMAX-ORIENT 'BUNGTITE'

These are inexpensive rectangular section Klunk Tanks, moulded in polythene.
2 ounce—95p 4 ounce—£1.05 7 ounce—£1.15
11 ounce—£1.30 14 ounce—£1.45 also 11 ounce Slant Feed Klunk Tank—£1.25.

Graupner

High quality square Klunk Tanks with top-mounted filler & vent
100cc (3½ ounce)—£1.45 250cc (8½ ounce)—£1.75
500cc (17½ ounce)—£2.00.
Four other square Klunk Tanks are also available:
60cc (2 ounce)—£1.00 160cc (5½ ounce)—£1.15
315cc (11 ounce)—£1.30 415cc (14½ ounce)—£1.45

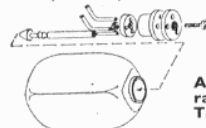

KAVAN 'SEALTITE'

Another top-quality range of plastic Klunk Tanks. Six sizes.

Feed, filler and vent pipes all pass through a synthetic rubber bung fitted with junk plates each side tightened by a central screw. These ensure a really tight, leakproof seal.
4 ounce—£1.45 6 ounce—£1.55 8 ounce—£1.60
10 ounce—£1.70 14 ounce—£1.75 18 ounce—£1.85

SCHUCO SLANT KLUNK TANKS

An original design with angled pipes, as shown.

40cc—£1.65
100cc—£1.75
150cc—£1.85
250cc—£2.00
400cc—£2.15
500cc—£2.30

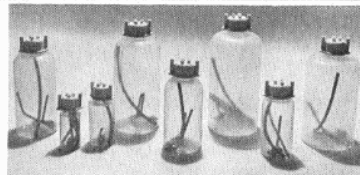
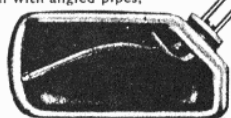

RIPMAX 'TUFTANKS' (8 sizes)

These are round Klunk Tanks giving the stated capacities in minimum diameter size—a useful feature when a tank has to be fitted in a small or narrow fuselage.

¾ ounce—55p 1 ounce—58p 2 ounce—60p 4 ounce—63p 6 ounce—66p 8 ounce—69p 10 ounce—72p 12 ounce—75p.

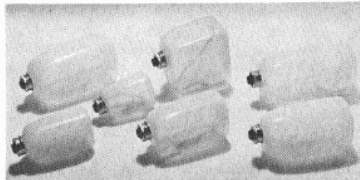

RIPMAX-IM 'PROFILED' TANKS

This range of Klunk Tanks—in 8 sizes—is of a shape to fit easily in any conventional fuselage, whilst occupying minimum space.

2½ ounce—£1.30 4 ounce—£1.40 6 ounce—£1.50
8 ounce—£1.60 10 ounce—£1.85 11 ounce (Extra Short)—£1.85 12 ounce—£1.95 14 ounce—£2.10

ALL AT YOUR LOCAL MODEL SHOP

KINDLY MENTION 'AEROMODELLER' WHEN REPLYING TO ADVERTISEMENTS



S. H. GRAINGER
(CALDMORE MODELS) LTD
108 CALDMORE ROAD,
WALSALL WS1 3RB
ENGLAND
 Tel: 25582
WORLD WIDE
MAIL ORDER CENTRE

RADIO CONTROL

Futaba ● MacGregor ●
 Skyleader ● Waltron ●
 Horizon ● O.S. Cougar ●
 Remcon ● Graupner ● Sanwa

KITS

Ripmax ● Keil Kraft ●
 Graupner ● Topflite ●
 Sterling ● Goldberg ● St.
 Leonards ● Pegasus ● Jolly
 Roger

MATERIALS

Balsa Wood ● Plywood ●
 Fibreglass ● Solarfilm ●
 Nylon ● Paints ● Adhesives ●
 Dopes ● Tissue

ACCESSORIES

Micro Mold ● Kavan ●
 X-Acto ● Swann Morton ●
 Tanks ● Wheels ● Rubber ●
 C/L Handles ● Airscrews

ENGINES

Rossi, Telco CO₂ ● Super
 Tigre ● O.S. P.A.W. ● HP.
 Enya ● O.P.S. K & B ● Merco.
 Veco ● E.D. DC. H.B. ●
 Webra, Fox

CATALOGUES

MAIL ORDER 35p. Post Free
 U.K. Overseas Airmail £1.50
 RIPMAX 95p Postage 55p U.K.
 Overseas 75p. Seamail, K. K.
 HANDBOOK 50p Postage 15p
 U.K. Overseas 25p Seamail.

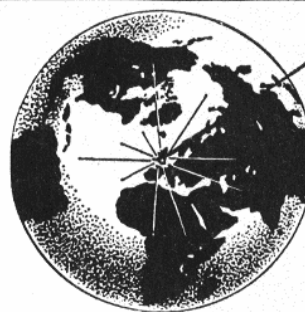

As near
to you
as
your
Post
Box
or
Telephone

THE SHOP WITH MORE FOR MODELLERS WORLDWIDE

NOT ONLY do we have the greatest selection of radio control, control line, and free flight kits, engines, and radio control units in the North West.

BUT ALSO the largest back up stock of spares, accessories, and goodies so essential for today's modeller.

THE MODEL SHOP (MANCHESTER)

209 DEANSGATE,
 MANCHESTER 3,

TEL: 061-834 3972

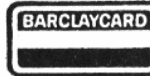
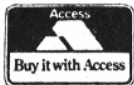

THE RANGE OF P.A.W. HIGH PERFORMANCE DIESEL ENGINES

BACKED BY 'BY RETURN' SPARES SERVICE

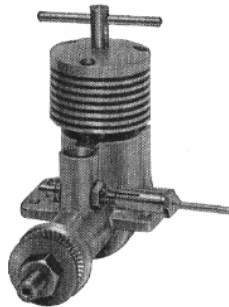

| | | | |
|---------------|---------------|---------|------------|
| P.A.W. 1.49DS | — Squish Head | — £7.50 | } Plus VAT |
| P.A.W. 2.49DS | — Squish Head | — £8.00 | |
| P.A.W. 19DS | — Squish Head | — £8.50 | |

All engines are now specially ported to produce a good performance when used with silencers or mufflers. All now also feature Squish Head type combustion chambers.

PROGRESS AERO WORKS
CHESTER ROAD,
MACCLESFIELD, CHESHIRE, ENGLAND
SK11 8PU

MORE PROTECTION!

MAP Insurance Scheme Now provides for £250,000 cover

To comply with constantly increasing requirements for Public Liability Insurance (as demanded by Local Authority and Government Departments), the MAP third party insurance scheme is now extended to provide £250,000 cover. This also corresponds with anticipated requirements for Society membership conditions. This offer embraces all forms of modelling activity, whether it be concerned with aircraft, boats, cars, etc. Just complete the form below and send it together with a remittance of £1.75, which will provide membership of the scheme for one year. Your certificate, badge, decals and card with insurance details will be sent within a few days.

Remember that the scheme applies to *regular* readers only (those who either have a standing order placed with their newsagent/model shop, or who have a direct subscription for any MAP modelling magazine).

Name (in full).....
 Address
 Date.....
 Registered No. (if renewing).....
 I enclose herewith postal order/cheque value £1.75 made to MAP Ltd for membership of £250,000 insurance scheme. I understand that membership is conditional in my placing a regular order for.....
 (state magazine)

KINDLY MENTION 'AEROMODELLER' WHEN REPLYING TO ADVERTISEMENTS

Aero Modeller

... something
SPECIAL
every month

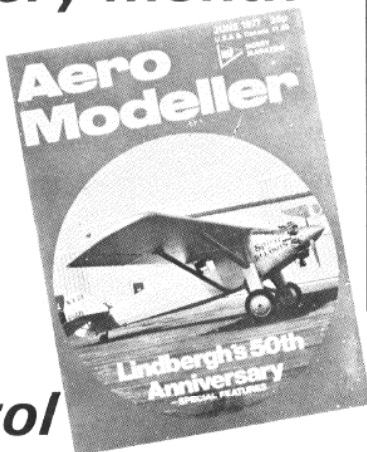

*if
Control
Line is
your interest*

Every month there are features on your favourite subject. Whatever your preference — combat, stunt, speed, racing, scale or sport flying, then you will find plenty of informative reading, while the world famous Plans Service provides the topmost designs. No matter whether you are an expert or novice, your interests are well catered for.

In addition, free-flight modelling is fully covered as well as engine news and tests, kit reviews and detailed scale three view drawings of full size aircraft.

In fact, *AeroModeller* is essential reading for all those with an interest in the hobby/sport.

Available from your newsagent or local model shop Every 3rd Friday price 35p.

MODEL & ALLIED PUBLICATIONS LTD

P.O. BOX 35, BRIDGE STREET, HEMEL HEMPSTEAD, HERTS HP1 1EE

Tel.: Hemel Hempstead 63841-2-3 (Mon.-Fri.)

EXTRA!

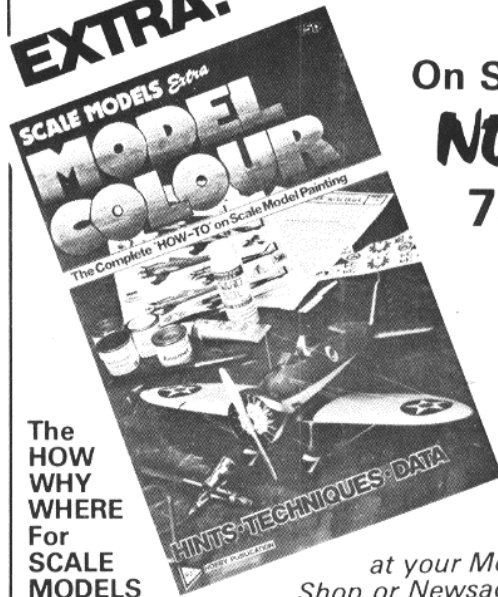

On Sale
NOW
75p

The
HOW
WHY
WHERE
For
SCALE
MODELS

at your Model
Shop or Newsagent

- ☆ **Painting Techniques**
- ☆ **Aircraft, Ships, Vehicles**
- ☆ **Airbrush Camouflage**
- ☆ **Natural Metal Finishes**
- ☆ **6 Colour Pages**
- ☆ **Tone Mixing Chart
for 260 Colours**

As models become more sophisticated they demand matching standards of detailed painting, yet there are many modellers unaware of even the most basic techniques necessary for model painting. Beginner and regular enthusiasts alike can learn many colouring and finishing techniques from this *Scale Models Special* which deals with what is probably the most demanding and interesting aspect of the modelling hobby. Within its 64 pages one will find colour mixing and reference charts for over 260 national colour shades, how to use the airbrush, applying camouflage to aircraft and warships, plus AFV painting, decals, general hints and tips, references and full colour artwork pages of famous aircraft, including the Albatros DV, the Me 109F and F4E Phantom.

Reserve your copy now as demand will be heavy.

Available from Newsagents and Model Shops or direct from the publishers (add 20p postage and packing).

Dealer enquiries welcome.



Model & Allied Publications Ltd.

P.O. Box 35, Bridge Street,
Hemel Hempstead, Herts, HP1 1EE.

There's no experience needed to enjoy the thrill of controlled flight with any one of the super Cox beginners range; they give the beginner a chance to take to the sky, confident in the knowledge that soon they will become proficient flyers and ready to take on the more advanced aircraft!

Just take a look at the **PT19 Trainer** and the **Falcon**, both fuel powered, control line, models that swoop, dive and even loop! The Falcon is a durable one-piece aircraft complete with tough landing gear. The PT19 a 22" wingspan aircraft has a control system that can be set to do more sensitive manoeuvres as the pilot develops more skill.

The Cox Electro-charged **Blazer**, a battery-powered, control line plane has a wingspan of 15 1/2". Just charge up your 6 volt battery and you're ready to fly at the flick of a switch!

These are only three of the super range available from Cox, whether you're a novice or you have your "wings" there is a model for you.

Cox Planes you can bank on them.

Take off with Cox!

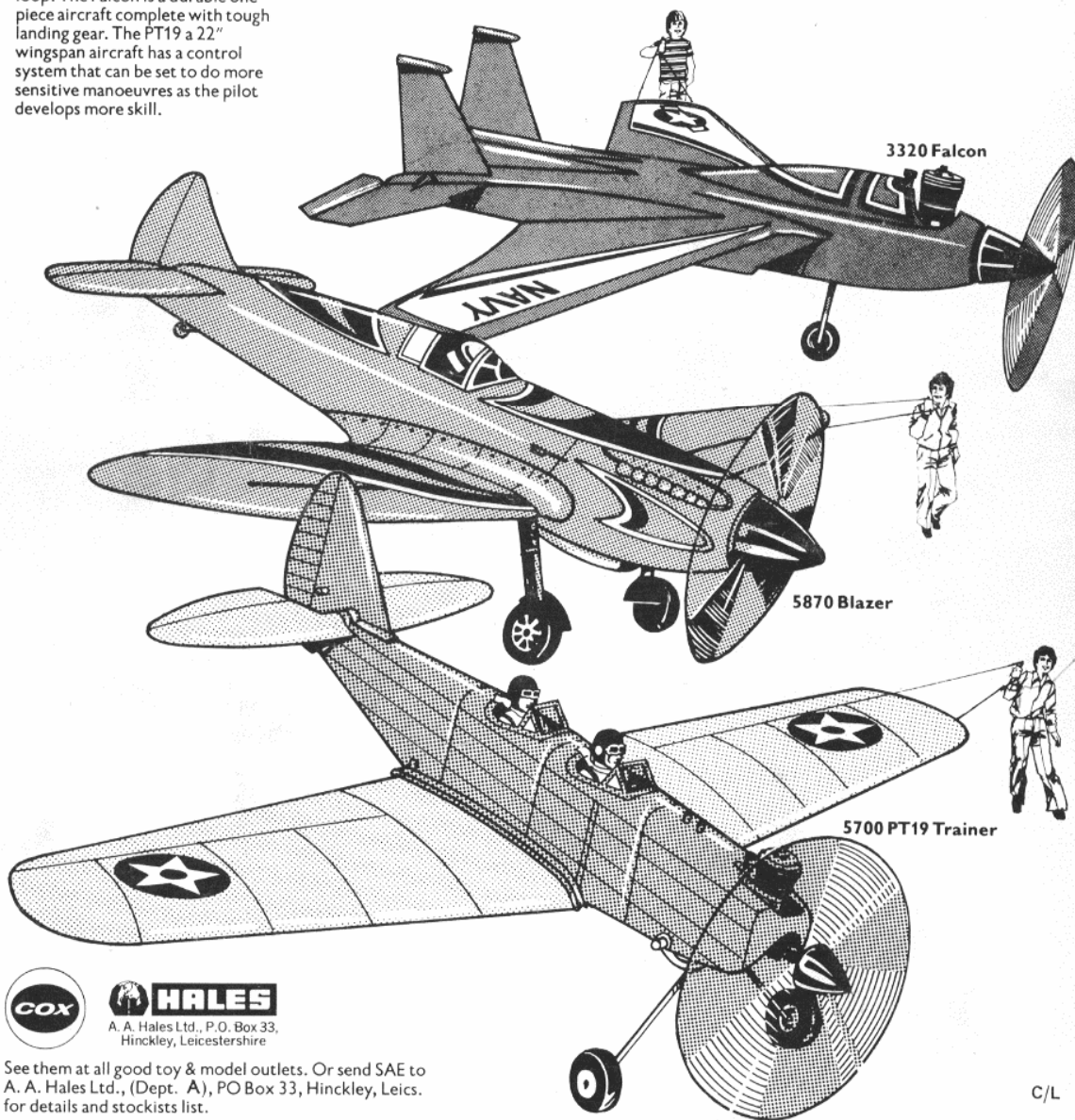

See them at all good toy & model outlets. Or send SAE to A. A. Hales Ltd., (Dept. A), PO Box 33, Hinckley, Leics. for details and stockists list.

C/L