

AMERICAN aircraft modeler

NEW FORMAT: 8 SECTIONS

- STUNT ● SCALE ● RACING ● PRODUCTS
- MODEL WORLD ● MODEL TECHNIQUES
- DURATION ● SPECIAL INTEREST

(IN EVERY ISSUE)



GO FOR BROKE

IS THE STORY OF AL RABE'S
NATS WINNING CONTROL LINE

SEA FURY

SEE PAGE 28



SCIENTIFIC

MUSEUM

Wood Ship

The kits that make Authentic Ship Modeling easy!

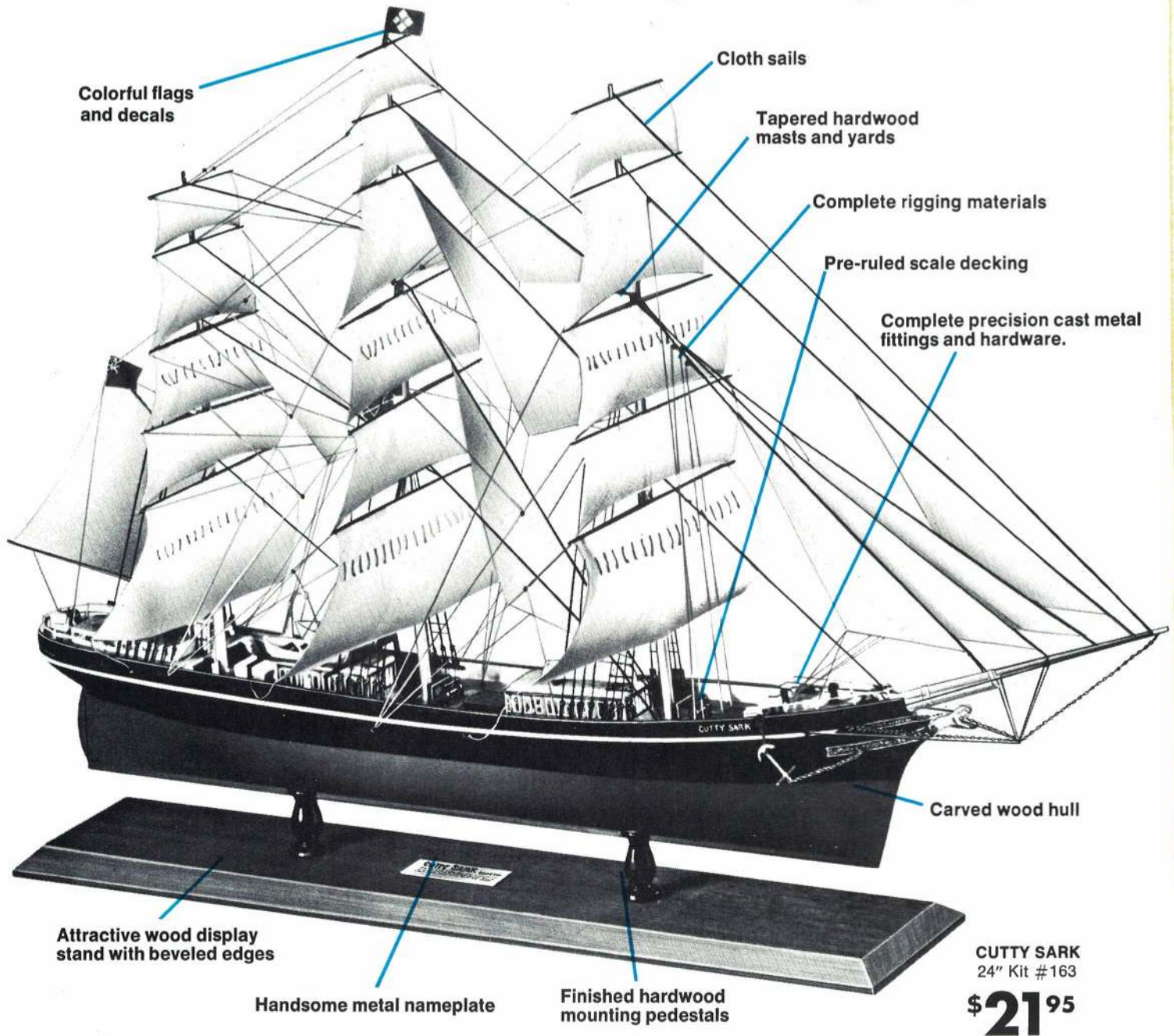

Colorful flags and decals

Cloth sails

Tapered hardwood masts and yards

Complete rigging materials

Pre-ruled scale decking

Complete precision cast metal fittings and hardware.

Carved wood hull

Attractive wood display stand with beveled edges

Handsome metal nameplate

Finished hardwood mounting pedestals

CUTTY SARK
24" Kit #163

\$21⁹⁵

Over 100 hand crafted parts including pre-carved wood hull and cast metal fittings.

- Full-size, step-by-step assembly instructions
- Highest quality wood materials used throughout
- Precision scale detailing

Now you can easily build a handsome museum quality wooden ship model like the famous clipper, "Cutty Sark", or any of the other historic sailing ships shown, even if you have never assembled a model kit before.

Each is authentic in every detail with fine craftsmanship and precision parts found in finished replicas costing hundreds of dollars. You'll be thrilled with your completed model and pleased by the salty romance it will lend to your living room, den or office.

SCIENTIFIC MODELS INC.

340E Snyder Avenue • Berkeley Heights, New Jersey 07922

SEE YOUR DEALER. If kits are not available at dealer, you may order direct from factory adding \$1.00 for postage and handling. Outside U.S.A. add \$2.00.

QUALITY

Models



A complete selection of the most famous historic ships



Kit 174 **CUTTY SARK**. The most famous Clipper. Includes realistic cloth sails. Length 15".\$9.95



Kit 177 **THE GOLDEN HIND**. Flagship of Sir Francis Drake. Authentic colorful cloth sails. L. 20" \$21.95



Kit 168 **EAGLE**. U.S. Coast Guard Training Ship. Cloth sails included. Length 13".....\$9.95



Kit 178 **SCHOONER AMERICA**. Originated America's cup races. Cloth sails included. Length 17". \$12.95



Kit 169 **H.M.S. BOUNTY**. Famous for mutiny against her commander, Captain Bligh. Length 13½" \$9.95



Kit 167 **FLYING CLOUD**. Clipper ship. Donald McKay's most famous Clipper ship. Length 13¾" \$9.95

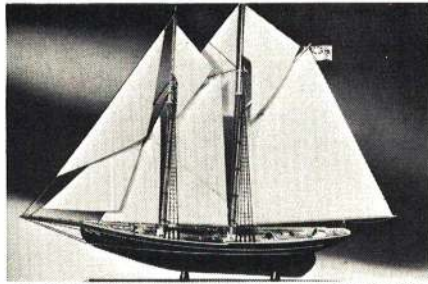

Kit 164 **BLUENOSE**. Famous Schooner with trim lines of a racing yacht. Cloth sails included. L. 24" \$21.95

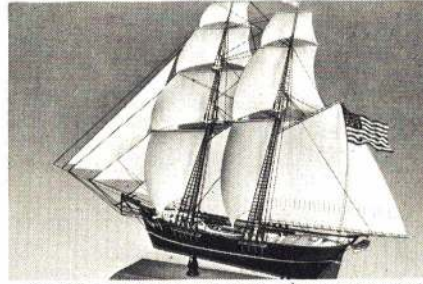

Kit 172 **BALTIMORE CLIPPER**. Pirate brig. Cloth sails included. Length 22½". \$21.95



Kit 170 **U.S.S. CONSTITUTION**. Old Ironsides. Fought 40 battles, never lost one. Length 14¾" \$9.95



Kit 171 **SEA WITCH**. Clipper ship. Cloth sails included. Length 27¼". \$21.95

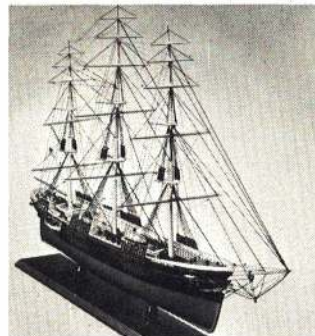

Kit 166 **U.S.S. KEARSARGE**. Civil War Gunboat. Cloth sails included. Length 27" \$24.95

Kit 165 **SOVEREIGN OF THE SEAS**. A majestic Clipper Ship of 1852. Length 23¾" \$21.95



NEW! ROBERT E. LEE Mississippi Steamboat Kit

Scientific's deluxe kit comes with all the trimmin's like pre-shaped smoke stacks, formed deck railing, and all the other precision parts you need to make a handsome museum quality replica. Once the fastest on the Mississippi, now it's a beautiful wood model Mark Twain would have been proud to own.

Kit #181
\$32.95



24½" L, 6" W, 9"H

Send for our big colorful catalog

... only 25¢

AMERICAN aircraft modeler

VOLUME 76, NUMBER 3—MARCH 1973

COVER PHOTO

This Hawker Sea Fury, one of the very few remaining, was meticulously restored to its original condition by owner Frank Sanders and photographed by Jim Larsen. See Al Rabe's Sea Fury on page 27.

MODEL WORLD

- 12 THE FASCINATING WORLD OF
INDOOR MODELING *by Thomas F. Vallee*
14 ON THE SCENE *by Monty Groves*

STUNT

- 18 Don Lowe on RC/AI Rabe on CL
20 CAJUN QUEEN *by Lou Penrod*
24 MACCHI C. 202 *by Scott A. Conradson*

MODEL TECHNIQUES

- 26 Fred Marks on RC/Bob Hatschek on FF
28 GO FOR BROKE *by Al Rabe*

DURATION

- 34 Bob Meuser on FF Sport/Carl Maroney on RC
36 FAI FREE FLIGHT FINALS *by Dick Mathis*

SPECIAL INTEREST

- 40 John Burkam on Helicopters/John Blum on CL Carrier/
Bob Stalick on FF Gliders, Power, Rubber, Indoor/
Bud Tenny on Indoor
42 SSP-5 *by Gene Rock*

PRODUCTS

- 48 NEW PRODUCTS CHECKLIST *by Frank Pierce*
50 AAM TESTS *by Don Jehlik, Fred Marks, Pat Murphy*

RACING

- 52 Bob Stockwell on RC/John Smith on CL

SCALE

- 64 Claude McCullough on RC/Walt Mooney on FF/
Bill Boss on CL
66 CURTISS ROBIN *by Ted Daigle*

FOR THE TENDERFOOT

- 56 VIGGEN *by Frank Scott*

GETTING STARTED IN RC

- 62 FIFTY-SIXTH IN A SERIES *by Jim McNerney*

ACADEMY OF MODEL AERONAUTICS

- 106 AMA'ER DISCOVERS NEW AUTOPILOT
107 KODAK'S NEW YORK SHOW
108 PRESIDENTS MEMO
109 AMA CHARTERED CLUBS
111 BACKGROUND—AMA/AAM
113 CONTEST CALENDAR

DEPARTMENTS

- 6 EDITORIAL
8 MODELER MAIL
84 AAM PLAN SERVICE
114 CLASSIFIED ADS/QUALITY HOBBY SHOPS

Potomac Aviation Publications, Inc.

733 15th Street, N.W.,
Washington, D.C. 20005

Edward C. Sweeney, Jr.
Editor and Publisher

Anna Maria Nunez
Managing Editor

Kelly M. Matthews
Art Director

Contributing Editors

Bob Beckman

John Blum

John Burkam

Bill Boss

Bob Hatschek

Don Jehlick

Don Lowe

Fred Marks

Carl Maroney

Claude McCullough

Jim McNerney

Bob Meuser

Walt Mooney

Frank Pierce

Al Rabe

John Smith

Bob Stalick

Bob Stockwell

Cliff Telford

Douglas Boynton

Advertising Sales Manager

David M. Boynton

Asst. Advertising Sales Manager

Carolyn A. Munson

Art Associate

William P. Kochanski

Computer Composer

Joseph R. Wright

Circulation Development

Gretchen Knowles

Subscription Manager

Mark K. Winter

Subscription Assistant

Harvey E. Cantrell

Business Manager

Abdul M. Sayeedi

Assistant Business Manager

Benjamin Millspaugh, M.S.

Advisor to Potomac Aviation Publications
for Aerospace Education

Stella Reed, M.S.

Advisor to Potomac Aviation Publications
for Libraries/Chairman, Board of Advisors
for Child Education

Published monthly by Potomac Aviation Publications, Inc., 733 Fifteenth Street, N.W., Washington, D.C. 20005. Edward C. Sweeney, Jr., President; Walter L. Hulstedt, Treasurer; Harvey E. Cantrell, Business Manager and Secretary.

ADVERTISING DEPARTMENT: All advertisers orders and correspondence to 733 15th Street, N.W., Washington, D.C. 20005. (202) 737-4288. **SUBSCRIPTION RATES:** In U.S., Possessions and Canada, 1 Year, \$9.00; 2 Years, \$16.00; 3 Years, \$23.00. Elsewhere \$11.00 for one year. Payable in advance. Single copies \$1.00. Six weeks are required for change of address. In ordering a change write to American Aircraft Modeler 733 Fifteenth Street, N.W., Washington, D.C. 20005. Give both new and old address as printed on last label. We cannot accept responsibility for unsolicited manuscripts or artwork. Any material submitted must include return postage. When writing the editors address letters: Editorial Office, American Aircraft Modeler, 733 Fifteenth Street, N.W., Washington, D.C. 20005.

POSTMASTER: Send Form 3579 to American Aircraft Modeler, 733 Fifteenth Street, N.W., Washington, D.C. 20005.

Second class postage paid at Washington, D.C. and at additional mailing offices. ©Potomac Aviation Publications, Inc. 1973. All rights reserved. Printed in the U.S.A.

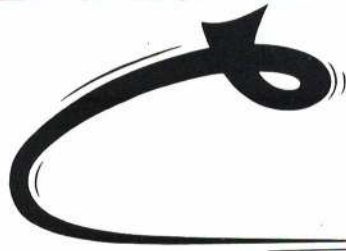

C. B. ENTERPRISES



PRESENTS A TOTALLY NEW CONCEPT IN ENGINE AND EXHAUST ACCESSORIES

Muffler Mount

Will fit most existing kits by moving firewall back. For .60 size engines only.

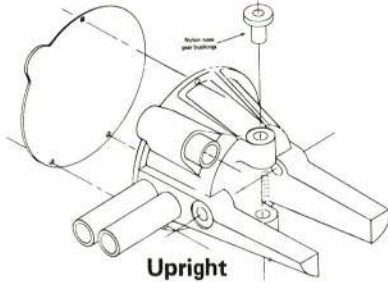

Upright



Manifold \$5.95

fits the following engines only:
HP61-72 Veco 61
Webra 61-OS 60
ST Blue Head 61
Enya III 60



Muffler Mount with two stacks \$24.95.

Extra stacks sold separately 65¢ each.

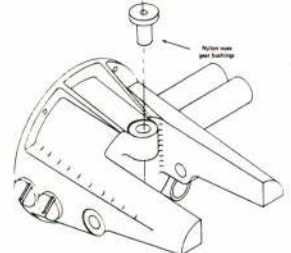

Inverted

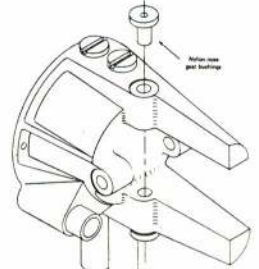

Side

Exhaust Piping

Use with C.B. Manifold (sold separately) for custom exhaust systems. Plastic tubing 6" lengths

Aluminum Fittings

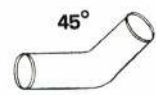
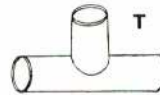

Aluminum Engine Mounts



Guaranteed Unbreakable. Motor Mount will be replaced if broken. Cast aluminum, heat treated and machined flat for all popular engine sizes.
.60F - \$5.95/.40R - \$5.95/.40F - \$4.95/.30 - \$4.85/.15 - \$4.65.

Racing Spinners

The fastest planes and engines in the world follow a C.B. Aluminum spinner across the finish line. Available in 2" and 2 1/4" sizes only.

Price 2" - \$10.95
2 1/4" - \$11.95

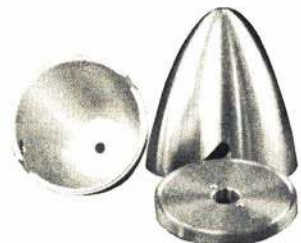

for further information write:

C. B. ENTERPRISES - 21590 CLOUD WAY - HAYWARD CA. 94545 - (415) 783-4868

Dealer inquiry invited



EDITORIAL

New Format

This issue brings a new style and format to AAM. Our Reader Survey, reported in the January issue, indicated that a long-desired change in the magazine's presentation of the hobby/sport of model aviation was possible. AAM is and will continue to be an all-interest model aviation publication. In the past we have viewed modeling as segregated into Free Flight, Control Line, Indoor, and Radio Control categories. Full-scale aviation appeared only as relevant to scale modeling.

Today modelers think more of the function of the plane as common ground than whether the model is controlled, or not. In other words, scale enthusiasts read and enjoy articles on scale models whether they are FF, RC or CL. Of course, Scale is one area which is common to FF, RC and CL, but we find combinations of FF, RC and CL in every other model type.

AAM's Where the Action Is section in past issues has been extremely popular. It seemed only natural to use the best features of this section, the writers and their subjects, to build the new format. So you will find a section in each issue devoted to the following categories: STUNT, RACING, SCALE, DURATION, MODEL TECHNIQUE, SPECIAL INTEREST, PRODUCTS, and MODEL WORLD. These sections will lead off with two or more Where The Action Is authors with their short columns, and a large photo of a model appropriate to that section. The WTAI columns have been shortened (and were already too short in the past) so issues will see occasional columns expanded into full-page stories when the author needs the space. This means much more how-to-do-it material.

It will probably take us several issues, perhaps half a dozen, to fully develop the format. Readers are encouraged to write with their suggestions. The magazine is limited in the total number of pages for articles, runover copy, advertising, and AMA section. So, it is difficult to accurately assess the amount of interest in the narrower modeling categories like Carrier, Combat, Unlimited Rubber, HLGs, or RC Cars, Helicopters, etc. As you read each section you will find how we have chosen to organize the modeling areas. Specific areas may get less emphasis than before and broader areas will gain more space. The amount of active building and participation in the categories does not necessarily mean that amount of interest in the category. For example, there are many more modelers interested in scale and racing than actually participate. A magazine must somehow determine how much attention to give the category.

One thing is certain, AAM will be publishing many more model articles in each issue. The articles will have to be a bit shorter and more compact, but more types of models will be shown and each issue will have more variety.

Years ago we had a title for a part of AAM called MODEL WORLD. We will bring this back to open each issue. It will consist of two parts in most issues, one the familiar On the Scene item about model events, and a new one called Uplift.

Potomac Publications is very much involved in the promotion of modeling. AMA is devoted to it. Almost every model club is promoting the sport. It is time the magazine offers a section where the promotional efforts can be presented as such. Uplift will be that place in AAM. We encourage brief article submissions of about a thousand words length with a dozen black and white glossy 4 x 5 photos describing a significant model promotion. This does not include promotion for profit or local club membership drives, but open encouragement to non-modelers to try our sport/hobby, get involved. It might also involve acquisition of a flying site through politics, persuasion of city or county governments, possibly even getting a super market or shopping center to support modeling. There are 12 issues each year, let's get Uplift started right away.

On the Scene will continue to present club related events, meets, etc. But the format will also allow major coverage of events in the new sections. We will have better coverage of international or world championship events. An FAI Stunt finals is more appropriate to the STUNT section than condensed into the one-page On the Scene format.

The full-page photos in the opening of the sections will be high quality photos of reader's models or the lead photo for an article. They often will be in full color. We seek submissions from readers for the photos. You need good equipment and sharp focus so that we can enlarge the picture to 8 x 10 size in the magazine. When sending in black and white shots, please include 4 x 5 glossy prints and negatives. Dime store or drug store prints can not be accepted. These places often return poorly developed negatives to you and the magazine just can't use them. If submitting color, by all means don't send color prints. Much contrast and color is lost in converting prints for publication. Use transparency film—that's film for making slides or use a high grade professional negative type film which is intended for either prints or slides.

AAM will pay you \$35 for color and \$15 for black and white when used to open the sections. With your photos please include several paragraphs describing the subject, who built it, who took the photo, and addresses.

We have always tried to make AAM's product coverage as professional as possible. Readers appreciate this but want still more product coverage. Advertisers want more products seen in product reviews and announcements. As you read this, Potomac will have brought into its staff a full-time photographer, New Products section editor and plans service manager. He is Eric Meyers who has just done the Editor's job on our first RC Products Directory. He has been doing all the new product announcements and photography for Potomac's Model Dealer magazine. Eric is a talented RC builder and Pattern flier and has also been involved in FF and CL as a sport flier.

Mr. Meyers will also manage the new format for equipment reviews. Gone is the format "Blue Ribbon Reviews." In its place will be brief factual product tests by AAM's team of specialists—Fred Marks, Duane Lundahl, Jim McNerney, Pat Murphy, Van Highers, Don Jehlik and Cliff Telford. For radio equipment tests and engine tests, expensive accurate testing equipment is being obtained to give you the very best in product evaluations. Including reviews of kits, we will no longer cover just RC products; CL and FF products fitting the coverage will be seen too. In every case, the product tests are based solely on our evaluation of the product and not on manufacturer's brochures. The categories for reviews are Engines, Radios, and Kits. Another objective gained is to significantly shorten the lead time between receiving the product or announcement of it and when you will read about it in AAM. There will not be a tie-in between the three reviews as in the past.

In closing I would like to add a point of general interest. Our editorial files for model articles is maintained so as to have approximately a full year of articles on each subject available at any time. Having reorganized the files to fit the new AAM format, I find that articles are needed in some areas. Submittals are sought for Stunt/Pattern models, radio controlled sailplanes and gliders, and all racing category articles or model designs.

Ed Sweeney



CARL GOLDBERG

NEW RANGER 42

The Versatile Almost-Ready-To-Fly Fun Model.



\$1995

Takes Single To 4 Channel Proportional Radio. Molded Fuselage... One Piece Molded Wing, Stabilizer and Vertical Fin. Also Free Flight. Span 42". Weight 26 oz. For .049-.10 Engines.

SKYLARK 56

\$2295



1-Piece Full-Length Sides

Now With 1-Piece Full-Length Sides. Takes 2 to 4 Channel Proportional. Span 56". Weight 3 1/2-4 1/2 lbs. For .15-.19-.35 Engines.

FEATURES:

- Semi-symmetrical wing section
- Coil-sprung nose gear... formed main gear
- Shaped and notched leading and trailing edges
- Cleanly die-cut ribs, fuse sides, formers, etc.
- New simple "Symmet-TRU" wing construction

JR SKYLARK

For Single or 2 Channel, Pulse or Digital. Span 37" Weight 18 oz. For .049 Engines. - \$8.95

Shoestring \$2995

The Goodyear Racer With Enough Area and Stability So You Can Fly It! For 4 Channel Proportional. Span 54"; Area 540 sq. in.; Weight 4 1/2-5 lbs. For .19-.40 Engines.

FEATURES:

- Shaped leading edges plus sheeting
- Symmet-TRU wing construction
- Full-length sides, sheeted trailing edges
- Cleanly die-cut ribs, formers, etc.
- Formed spring aluminum landing gear
- Semi-symmetrical wing section.



THE FLYING FALCONS

More Falcons have been built and flown in the past 10 years than any other R/C. For values and features in a functional, rugged airplane, your best bet is a Falcon. Every design element engineered for simplicity and fast-building.



FALCON 56 \$19.95 Medium-Size Trainer. Single To 4 Channel Proportional. Span 56". For .15-.19-.35 Engines.

SR. FALCON \$36.95 Standard Big Trainer. 4 Channel Proportional. Span 69". For .35 To .60 Engines.

JUNIOR FALCON \$7.95 Small Trainer. Single or 2 Channel. Span 37". For .049 Engines.

MODELS THAT ARE REALLY GREAT TO FLY!

SKYLANE 62

Semi-Scale Beauty in a Great Flying Model!



36.95

Tough, Roomy Cabin and Front End. For 2 To 4 Channel Proportional. Steerable Nose Gear. Span 62". Weight 4 1/2-5 Lbs. . . . For .35 To .45 Engines.

FEATURES:

- See-through cabin, with die-cut plywood cabin sides
- Shaped leading edges plus sheeting
- Cleanly die-cut parts that fit
- Clark Y wing section, hardwood struts
- Steerable nose gear, formed main gear

1/2A SKYLANE \$9.95

For Single or 2 Channel, Pulse or Digital. Span 42". Weight 22 oz. For .049 To .10 Engines



All Carl Goldberg Models Come With All Major Fittings Such As Nylon Snap-Links, Control Horns, Snap 'R Keepers, Full Size Plans, Illustrated Step By Step, And Folder on How to Set Up and Operate R/C Models.

LOOK WHAT A MODELER SAYS!

"Enclosed is a photo of a model of your SKYLANE 62 which I have just completed. I enjoyed building this plane, it is the first model that I have built in 25 years. Several months ago I observed a group of men flying some R/C models and this rekindled my interest in model planes. Having never built an R/C model, I was dubious which model to build. After some investigation I settled on your kit and I was not disappointed. It was so different from anything that I had built previously and I must say that it went together very easily. The plans were complete, left nothing to guess work. I followed the plans exactly with the exception of the motor and I installed a slightly larger motor, a Max OS 40. I am very pleased with the results. I felt I should write and let you know how much I appreciate this kit and I hope to be able to build all of your planes eventually. Again thanks for such a fine kit."

Arnold B. Johnson
Troutville, Virginia

AVAILABLE IN CANADA

P.S. For best service, see your dealer for items you want. If not available, write direct; add 35¢ per item (75¢ outside U.S.). Minimum order \$1.

CARL GOLDBERG MODELS INC.
2543 W. Cermak Rd., Chicago, Ill. 60608
I am sending 20¢ for 8 pg. Illustrated Catalog with "Recommendations in Starting in R/C." Basic Explanation of R/C Equipment, and Radio Control Definitions.

NAME _____
 ADDRESS _____
 CITY _____
 STATE _____ ZIP _____

CARL GOLDBERG MODELS INC.
2545 WEST CERMAK ROAD • CHICAGO, ILLINOIS 60608

JACK STAFFORD MODELS

Super Minnow Wins
4th NATS in a Row!

12111 Beatrice · Culver City, CA 90230



50" Span Formula 1
Winner 69, 70, 71 & 72 NATS
Super Minnow \$49.95



Messenger 44" SPAN 40-60 ENGINE
FULLY AEROBATIC \$45.95



Chipmunk 59" SPAN 40-60 ENGINE
FOAM WING \$49.95



72" Span 56-65 Engine
Comanche—All Balsa Cowl—\$49.95



Aircoupe 63" SPAN 35-60 ENGINE
SCALE TRAINER \$49.95



Super Midget 48" SPAN NEW
FORMULA I \$49.95



FAI & FORMULA II
Mustang WITH FIXED GEAR
WITH RETRACTABLE GEAR \$49.95
\$54.95



40-60 Engines
Weekender Prefab Basic Trainer \$49.95



38 Span 15 Engines
Mustang QM Quarter Midget \$34.95

Send stamp for new catalog.



MODELER MAIL

Needs Skyranger info

I am in the process of building a scale RC model of a 1941 Rearwin model 175 Skyranger as you can see in the photo. I am in need of information on cockpit detail, as I am completely ignorant of seating arrangement (side-by-side or tandem), type of controls, stick or steering wheel. I also have no idea of what type of instruments this fine airplane had.

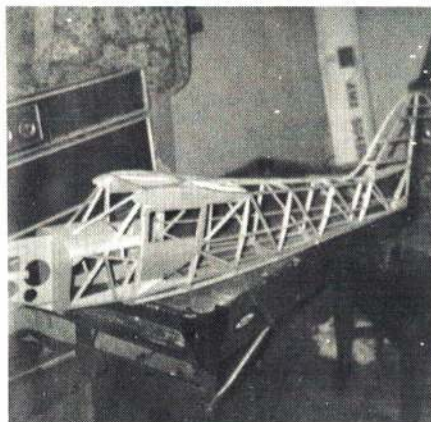

If there are any readers who could help me with these details, or can furnish information on how to contact the plane's designer, Gene Salvay, it would be greatly appreciated.

Frank Gibson, Rt. 2, Box 33
Dittmer, Mo. 63023

Lots of questions

As an avid modeler and a rookie RCer, I commend you for the various editorials you have presented, especially the last huge editorial survey of readers in the January issue of AAM.

I am going on a trip to Italy and I would like to look into RC equipment in Rome and Milan, as well as Athens. If any of your readers has information on Italian RC units, or where I can find a hobby shop in Rome, please write.

I am also looking for a source of data on the Hawker-Siddeley Harrier (one and two seater versions).

Jeff Chomyn, 215 Crocus Ave.
Ottawa K1H6E7, Ontario, Canada

Requests assistance from Germany

I would like to contact someone, perhaps in Germany, who could supply detailed plans of Me-109 and FW-109-s for scale RC application. I need information on such things as airfoils, weights, available power, cockpit details, etc.

Geza Tihanyi, 43607 Lancaster Ct.,
Plymouth, Mich. 48170

AAM suffering from airship anemia?

American Aircraft Modeler in my opinion is the most informative and enjoyable general modeling magazine that is available today. Your selection of topics provides great variety for modelers.

However, there is one area in which your magazine is definitely anemic, and that is lighter-than-air modeling. There are growing numbers of modelers being attracted to this unusual and spectacular branch of model aviation. There are many flying model airships in the United States today, not to mention the scores of model hot-air balloons. I myself have experimented with these fantastic models and have found them to be easy to build, spectacular in flight, and just plain old downright fun!

I believe that it would be in AAM's best interest to include a column, perhaps in the Special Interest section, devoted to airship modeling. I feel that such a column would be of great interest to all modelers and be especially gratifying to airship modelers who are,

(Continued on page 100)

An uncharted flight through the tricky price maze.



If you're about to shell out money for R/C equipment, be careful. The least expensive path can be costly in the long run. And a high price doesn't always mean high quality. The competition is treacherous, and some manufacturers fly by night.

Over the years EK-logictrol has steered an unwavering course to leadership in the field of R/C flying. Price-wise, we compete with anyone. Technologically, we have no rivals.

All our units—the LRB for beginners, the moderately priced Champion and the Super-Pro for well-seasoned flyers—feature adjustable mono-ball sticks, something you can't find on most units, regardless of cost. You regulate stick tension to your individual preference. The result is the cleanest, most precise feel in R/C flying. And all our units use our servos, the smallest, lightest, most responsive servos anywhere.

Everything considered, there are no better buys in R/C flying. The LRB—\$119.95 (one or two sticks). The Champion—\$349.95 (six channels, two sticks); \$369.95 (six channels, one stick). The Super-Pro—\$439.95 (six channels, two sticks); \$459.95 (six channels, one stick).

EK-logictrol is the reliable way out of the tricky price maze.

EK-logictrol. Try it. Price it.

Fly it.

And if you mean to stay in the air, take the controlled approach.

EK-logictrol

The controlled approach

For our full-line brochure, write: EK-logictrol, 3233 W. Eules Blvd., Hurst, Texas 76053

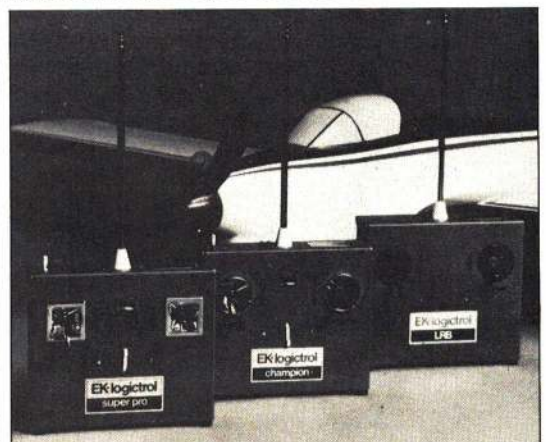

HP HOBBY PEOPLE

130 EAST 33RD STREET LOS ANGELES CALIFORNIA 90011
 PRICES GOOD UNTIL MARCH 20TH.

CAN'T WAIT? CALL (213) 233-4484 FOR FAST C.O.D. SERVICE

NEW K&B

Ball bearings. Specially designed Perry carburetor. Squish band combustion chamber. Head machined from solid aluminum stock.

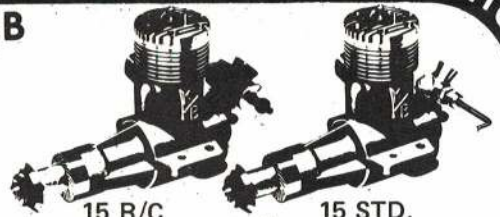

SALE

15 R/C
REG. \$37.00
\$27.88

15 STD.
REG. \$35.00
\$26.47

DO-IT-YOURSELF R/C COMBINATION SPECIAL

 V.K. NEIUPORT	 R.C.M. TRAINER	 STERLING STEARMAN P.T. 17	 SVENSON MINI-MULTI	 SVENSON WESTERLEY	 LANIER TRANSIT
 LANIER COMET II	 BRIDI KAOS	 TOP FLITE P-51 MUSTANG	 LANIER AZTEC	 JOY MARS	 MIDWEST SKY SQUIRE

LANIER CESSNA
 S.T. .60R/C
 FOX .60R/C
 VEVO .61R/C

HOBBY PEOPLE DOES IT AGAIN! TAKE YOUR PICK OF ANY ONE OF THE ABOVE SEVEN R/C AIRPLANES AND ANY ONE OF THE THREE R/C ENGINES ON THE LEFT FOR A VERY SPECIAL LOW, LOW PRICE. MIXED OR MATCHED ANY WAY YOU PLEASE. THIS IS ONE DEAL YOU CAN'T AFFORD TO PASS UP! UP TO A \$120.00 VALUE.

DISCOUNT \$69.99

TESTORS .19R/C
 TESTORS .29R/C
 TESTORS .35R/C
 TESTORS .40R/C
 FOX .40R/C
 FOX .25R/C

HOBBY PEOPLE WON'T QUIT GIVING YOU A GOOD DEAL! TAKE YOUR CHOICE OF ANY ONE OF THE ABOVE SIX R/C AIRPLANES AND ANY ONE OF THE LISTED ENGINES ON THE LEFT FOR A VERY SPECIAL LOW PRICE! 36 DIFFERENT COMBINATIONS ARE POSSIBLE! (THE WORLD'S LARGEST MAIL ORDER HOBBY DEALER!) VALUES UP TO \$69.95 **\$39.99**

Svenson FLY-BOY
 REG. \$55.00
 our price **\$24.99**
 includes all hardware

Svenson SLY-CAT
 REG. \$50.00
 includes all hardware
 our price **\$34.88**

SVENSON SPECIAL

Limited supply
 Svenson AZIZO GLIDER
 REG. \$28.00
 includes all hardware
 our price **\$17.76**

Svenson MINI-MULTI
 REG. \$25.00
 our price **\$18.88**
 includes all hardware

Svenson K8B GLIDER
 REG. \$50.00
 our price **\$34.88**
 includes all hardware

HOBBY PEOPLE TAP & DRILL SET

 A necessity for every modeling shop. Includes a tap and drill in sizes 2-56, 3-48, 4-40, and 6-32.
 REG. \$10.00
SALE \$7.99

ELECTROCONE GLOW PLUGS

 ELECTROCONE center electrode. Specifically designed to idle at a lower speed than any other plug.
 R/C 3for **\$1.99**
 STD. 4for **\$1.99**

TATONE STARTER & CHARGER SALE

 This hang on nicad battery is what we believe to be a much overlooked and easiest to use starting battery. No hookup wires, clips or water levels to watch.
 REG. \$7.00
\$4.57

ACCESSORY Sale

DUBRO NYLON QUIK LINKS	REG. \$2.48	\$1.99 doz.
DUBRO R/C TANK FILER	REG. 98	76c
DUBRO NYLON HINGES	REG. \$2.49	\$1.67
DUBRO K-620 KWICK GLOW CLIP	REG. \$1.05	\$1.67
DEVCON EPOXY	REG. \$2.00	3 for \$4.47
H.R. RUBBER BANDS	REG. \$1.25	67c
TATONE HINGE IT	REG. \$2.05	\$1.99
PERFECT FUEL PUMP	REG. \$1.25	89c
PRATHER WEIGHTS	REG. \$1.25	\$1.99

SPECIAL DISCOUNT!

QUIET TONE MUFFLER

 For the following engines:
 VEVO .19R/C, VEVO .61R/C,
 K&B .40R/C, O.S. MAX .15STD
 O.S. MAX .15R/C, O.S. MAX
 .50R/C, O.S. MAX .60R/C.
 REG. \$10.00
\$3.47

HOBBY PEOPLE FILE SET

sale
 REG. \$10.00
\$5.99
 12 beautifully made needle files. Made of SHEFFIELD steel.

X-ACTO no.82 KNIFE CHEST

 NOS. 1,2 and 5 knives plus 9 assorted extra blades. Handy natural wood finish chest.
SALE \$4.99

130 EAST 33RD STREET, LOS ANGELES, CALIFORNIA 90011

FROLIC FRIENDS "THE COMMODORE" R/C YACHT
 THE FIRST RADIO CONTROLLED YACHT, READY TO SAIL, COMPLETE WITH TRANSMITTER, RECEIVER AND SERVO. HULL SHAPE, WEIGHT AND BALANCE, AND SAILS HAVE BEEN CAREFULLY ENGINEERED TO GIVE EXCEPTIONAL PERFORMANCE. LENGTH 48", HEIGHT 72".
 REG. \$150.00 **\$99.99**

JEROBEE BANDERO
 RADIO CONTROLLED
 COMPLETELY ASSEMBLED WITH ENGINE AND UNI-SERVO RADIO CONTROL SYSTEM. NEW 1/12 SCALE RACING. FOUR FOOT TURNING RADIUS. RANGE MORE THAN 100 FEET. UP TO 180 MPH SCALE SPEED. TESTED TO AEROSPACE STANDARDS.
 COMPLETE AND READY TO RUN.
HOBBY PEOPLE SPECIAL PRICE
 Batteries not included. REG. \$89.99
\$49.99

CONTROL LINE IS ALIVE AND WELL AT H.P.
PICK-A-PAIR COMBINATION 1/2 A C/L PICK-A-PAIR SPECIAL

Dumas Smoothie
FREE!
 Your choice with any Combination: Pylon .015 control line OR .018 control line OR a 'HOT ROCK' U/C Handle; yours for the asking!
FREE!

Sterling Ringmaster
Sterling F-51 Mustang
Sterling YAK-9
\$19.99

Dumas Mustang
Dumas Chief
VALUES UP TO \$32.00!

HOBBY PEOPLE DOES IT AGAIN! TAKE YOUR PICK OF ANY OF THE ABOVE SIX PLANES & YOUR CHOICE OF THE FOLLOWING FIVE ENGINES: TESTORS 295TD, TESTORS 305TD, FOX .295TC, FOX .295TD, FOX .30X MIXED OR MATCHED ANY WAY YOU PLEASE FOR A LOW LOW SPECIAL PRICE! THIS IS ONE DEAL YOU CAN'T AFFORD TO PASS UP! DON'T FORGET THAT YOU ALSO GET FREE WITH ANY & EVERY COMBINATION YOUR CHOICE OF ITEMS IN THE BONUS BOX AT THE RIGHT.

STERLING BEGINNERS RINGMASTER
MIDWEST MINI WAR BIRDS
VALUES \$10.00
\$6.99
PLUS
 YOU GET ONE AIRPLANE PLUS A BABY BEE .049 OR THE NEW TESTORS .049.

TESTORS ENGINE SALE

REG. \$14.95	- 19 STD.	\$ 9.99
REG. \$15.95	- 29 STD.	\$10.75
REG. \$27.95	- 19 R/C	\$15.48
REG. \$23.95	- 29 R/C	\$15.99
REG. \$24.95	- 26 R/C	\$16.83
REG. \$25.95	- 40 R/C	\$17.47

049 WITH TANK MOUNT AND PROP. REG. \$0.00
\$ 2.99

SALE

TOP FLITE SUPER COMBO. NOBLER

PLUS
VALUE \$28.00
\$22.88
K&B .35

COX ENGINE SALE

TEE DEE .010	REG. \$11.98	\$8.33
TEE DEE .020	REG. \$11.98	\$8.33
TEE DEE .049	REG. \$11.98	\$8.33
TEE DEE .09	REG. \$13.98	\$10.47
MEDALLION 15 REG.	\$14.98	\$10.99
MEDALLION .09 REG.	\$11.98	\$8.33
MEDALLION .049 REG.	\$9.98	\$7.76
BABE BEE .049	REG. \$5.98	\$3.99

GOLDBERG VIKING
 REG. \$5.95
 NOW **\$4.96**

COX T.D..051 REG. \$11.98
 NOW **\$8.88**
COMBO. PRICE
\$12.99
 VALUE \$18.00

COMPETITION STARDUSTER 600
 REG. \$11.00
\$9.99

PLUS
COX MEDALLION 15
 REG. \$15.00
\$10.46
COMBO. PRICE
\$18.88
 VALUE \$26.00

GOLDBERG DOUBLE VOODOO

REG. \$9.00
PLUS FOX 25
 REG. \$13.00
VALUE \$22.00
\$15.99

SUPER KIT SALE GOLDBERG

FALCON 56	REG. \$20.00	\$13.99
RANGER 82	REG. \$19.95	\$14.99
DU BRO		
WHIRL BIRD	REG. \$125.00	\$84.71
SPORTSMAN 600 REG.	\$60.00	
OUR PRICE		\$47.88
DUMAS SPECTRUM	REG. \$6.50	
OUR PRICE		\$5.99
EVOLUTION	REG. \$20.00	
OUR PRICE		\$14.99
JENSEN UGLY STICK	REG. \$50.00	
OUR PRICE		\$37.88
JETCO NAVIGATOR	REG. \$15.95	
OUR PRICE		\$12.99
ROYAL CORSAIR F.W. 190	REG. \$69.99	
OUR PRICE		\$62.88

OVER 200 PAGES FULLY ILLUSTRATED 1973 GIANT DISCOUNT HOBBY CATALOG

THE FINEST ALL IN ONE HOBBY CATALOG EVER FEATURING: R/C SPORTS, PLANES, BOATS, CARS, RADIOS, ENGINES, ETC. PLASTIC MODELS, WOODEN SHIP MODELS, COMPLETE O & N RAILROADING, EDUCATIONAL SCIENCE AND MUCH MUCH MORE!

HOBBY PEOPLE
 130 EAST 33RD STREET
 LOS ANGELES, CALIFORNIA 90011

NAME _____
 ADDRESS _____
 CITY _____ STATE _____ ZIP _____

POSTAGE AND HANDLING:
 UP TO \$5.00 ADD 60¢ \$20.01 TO \$30.00 ADD \$2.50
 \$ 5.01 TO \$ 8.00 ADD 80¢ \$30.01 TO \$50.00 ADD \$2.70
 \$ 8.01 TO \$15.00 ADD \$1.10 ORDERS OVER \$50.00
 \$15.01 TO \$20.00 ADD \$1.50 PLEASE ADD \$3.00
 CALIFORNIA RESIDENTS ADD 5% SALES TAX!

HOBBY PEOPLE'S WAREHOUSE STORE
 OPEN TO THE PUBLIC MON. - FRI. 9 am to 4 pm. OPEN SAT. 9 am to 5 pm.
 130 EAST 33rd STREET, LOS ANGELES, CALIFORNIA 90011
 TELEPHONE: (213) 233-4484

AME HEAT GUN
 Gives Monokote and Solarfilm a professional finish. Complete with case.
 REG. \$25.00
\$19.47

SUPER SHOE
 Specially designed for model building. Will fit the sealing iron below.
\$2.98

SEALING IRON
 Perfect for Monokoting. Heavy duty heating element.
 REG. \$12.98 **\$9.99**

130 EAST 33RD STREET, LOS ANGELES, CALIFORNIA 90011

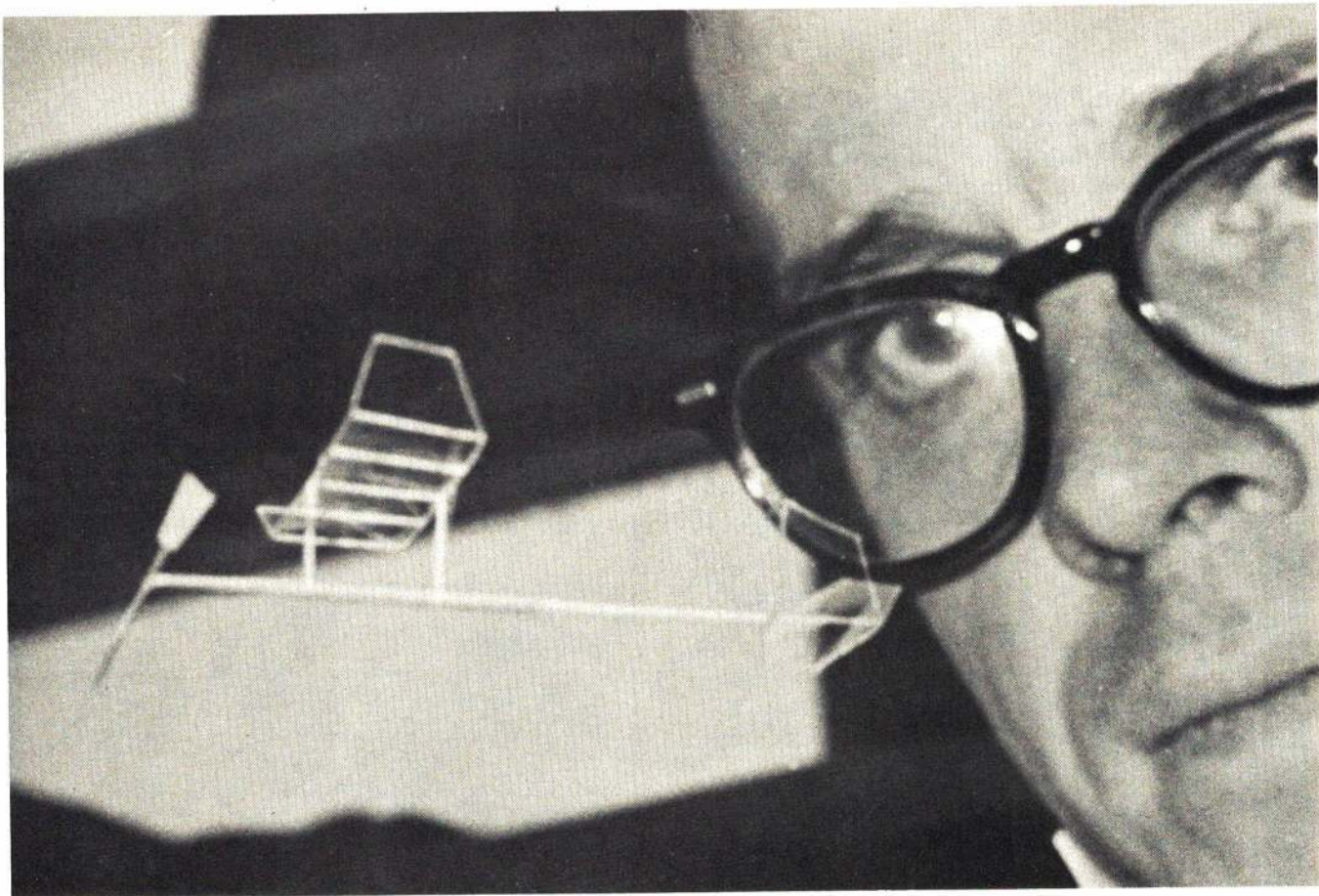

The Fascinating World of INDOOR MODELING

Perhaps the most unforgettable modeler I've ever met is Bill Bigge. As most serious Indoor modelers already know, Bill is a master Indoor modeler who, when the spirit moves him, is a fierce competitor in the contest wars. Bigge has twice been a member of U.S. Indoor FAI teams, placing third in the first World Indoor FAI Championship.

Fortunately for other fliers in the Indoor contest circuit, Bill has often neglected pure contest flying for the unorthodox Indoor model, or pure fun-type Indoor models.

Bill is a member of that small fraternity of Indoor modelers, for whom Indoor modeling is an art form, a means of artistic expression, as well as a competitive sport and a science. He is most proficient in the design, building and flying of Indoor autogyros, helicopters, ornithopters, and other Indoor models—and has a great deal of fun at it.

I first met Bill some years ago at the organizational meeting of the D.C. Maxcuters Free-Flight Club. After the business meeting, he opened a shoe box he just happened to have with him, and proceeded to turn in three min. maxes in Ernie Violetts' living room with a Bud Tenny Parlor Mite.

We were completely fascinated by this little model and in short order a

A visit with Bill Bigge.

THOMAS F. VALLEE

number of us were trying to duplicate Bills' performance at regular Indoor sessions. It was not at all unusual to see Bill show up with an autogyro, a birdlike ornithopter, or an Indoor helicopter at club meetings or flying sessions. Many of these models were AMA record attempt models, but many more were strictly fun models sometimes of wildly unusual design.

A matchbox with two tiny indoor jobs. Both fly very well.

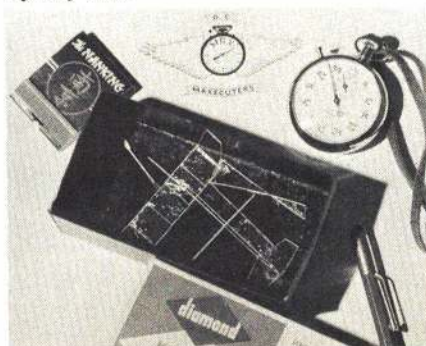

One model of particular interest was one I nicknamed the Closet Mite. After club meetings, the D.C. Maxcuters used to drop by a local coffee shop for coffee, doughnuts and a short bull session before going home. One memorable night Bill brought out another box, only this time it was a match box.

In this match box was a complete, functional, flying model, perhaps the world's smallest flying model plane ever. Complete with rubber, this two-in. span model weighed .0006 oz., soaking wet. Powered by a rubber strand from a piece of rubber from a sock's elastic thread, the tiny model could do almost a minute, never getting more than a few feet above the floor. To make a long story short, Bill wound the ship up and launched the Closet Mite. Moments later the microscopic model was happily buzzing around the head of our table when the waitress arrived with our check. Mistaking the Closet Mite for a large bug, the young lady valiantly leaped to our defense, frantically trying to swat down the offending "insect". Fortunately, she missed! This really brought down the house and made that meeting night truly a night to remember!

(Continued on page 16)

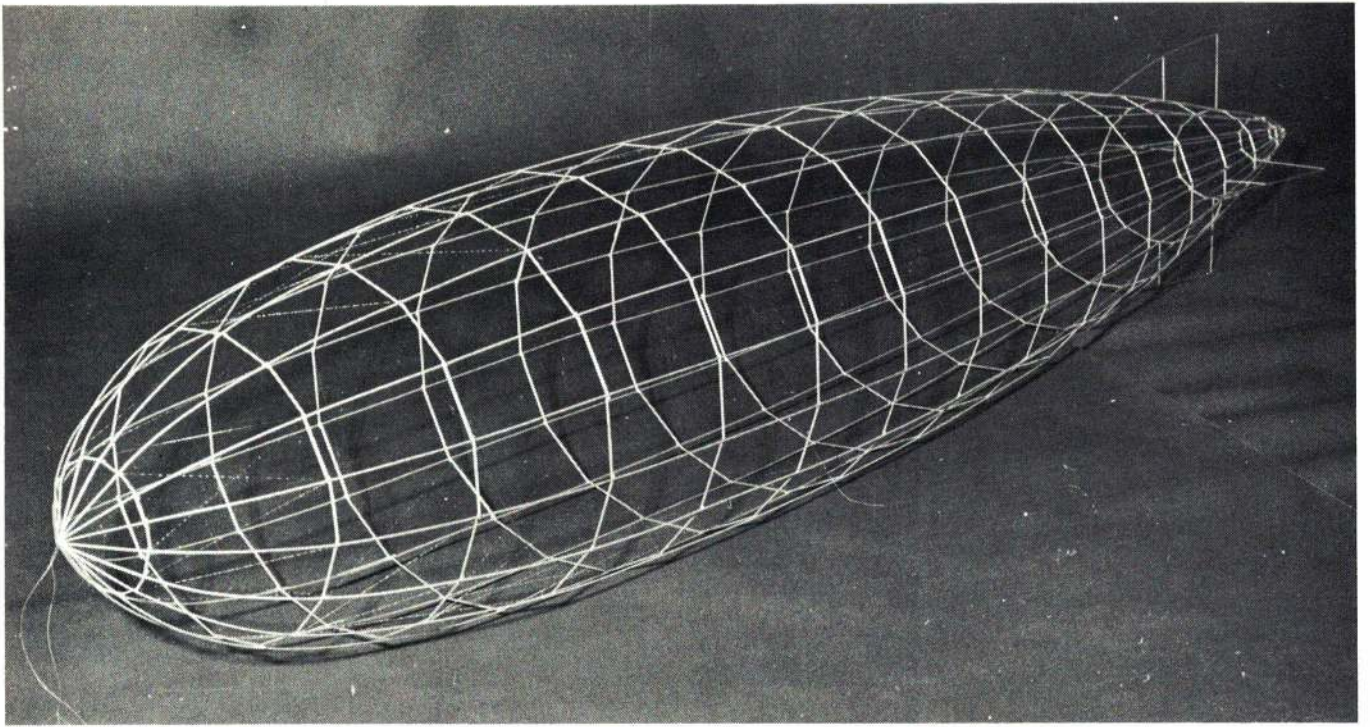

Above: That hull is a form of art. A sneeze could destroy it! Right: The monster climbs only from propeller power. Flight attitude is adjusted by the weight at the end of those strings. Below: One of Bill's most unorthodox indoor jobs, and clearly the largest, is the dirigible. It is rubber-powered. Left: To fly, it needs a bit of gas. It is not pressurized at all and is adjusted for slight negative bouyancy.

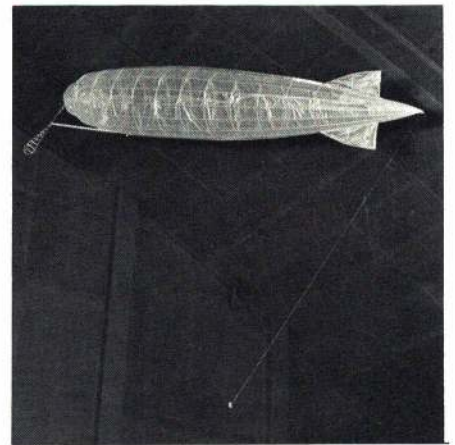

ON THE SCENE

WEST COAST RC SCALE CHAMPIONSHIPS

MONTY GROVES

The Hill Country Air Museum at Morgan Hill, California provided an ideal setting for the West Coast RC Scale Championships. Along with a beautifully manicured grass runway, little or no wind made good flying conditions for the models and some antique 1:1s. For the first in a series of quality scale contests, these conditions, the quality entries, and spectators lolling on a nearby shaded grassy mound created a slight touch of "the Rheims" about the meeting.

Irv Perce, owner of the newly developed air museum, made the facilities available to Contest Manager Bob Snyder and to the sponsoring Pioneer RC Club of Sunnyvale, California. Quite a few mint condition aircraft including, among others, a Ford Trimotor, Curtiss Robin, Curtiss Junior and the one and only remaining Stearman Hammond, are nestled among some classic antique cars, and there for all to see.

Winning the FAI Overall Championship was a bomb-dropping Etrich Taube built and flown by Mel Ford of Studio City, California. Other FAI winners included Floyd Carter's exceptionally well-detailed Aeronca. More physical excitement was provided by Nick Maire's Fokker DRI which really caught the flight judges' attention.

In the Pioneer Standoff class Gene Pond's "Little Toot" took First Place with very realistic flights. Pat Ray, with his fantastic "screamin'" P-38 raised goose pimples of nostalgia on spectators and contestants when he flew. Between Pat's P-38 and Bob Divita's Twin Comanche, a total of eight twin-engine flights were made without incident or engine loss.

A specially designed three-color patch issued to each competitor commemorated the contest. This special patch idea, started by the Pioneers four years ago, is beginning to catch on with other contests up and down the State. In addition to the normal trophies, over \$200 in merchandise prizes were awarded to contestants and contest workers during the two-day event.

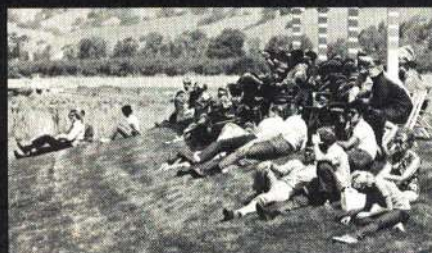

RIGHT

California climate and a picturesque grassy knoll provide an ideal point for spectators.

LOWER RIGHT

Armed and primed, Nick Maire's Fokker DRI, for the moment, is in its least dangerous state—on the ground.



BELOW

The winners and their exceptional aircraft. How about that perfectly smooth, close-mown grass runway!

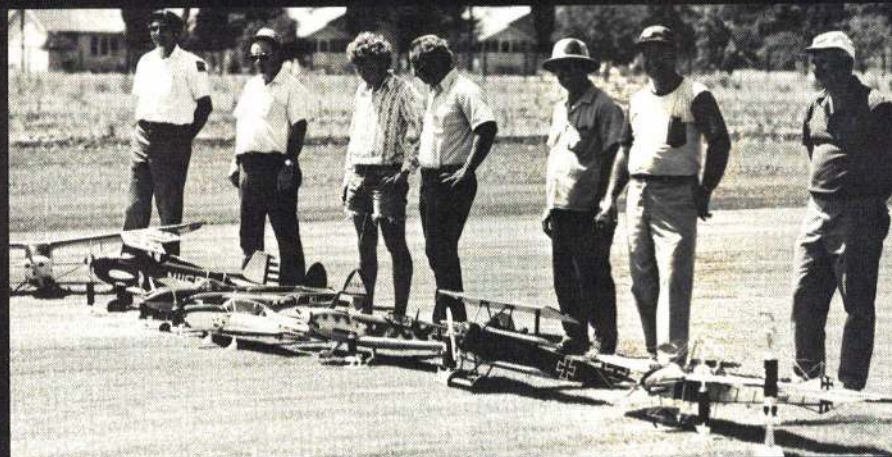

RIGHT:

Oops! That's a real Curtiss Robin. To make one like it, see Ted Daigle's article on page 66.

LOWER RIGHT

One of the Standoff Scale entries is the bright red P-51 in Paul Mantz colors by D. Bowers.

BELOW

This model you have to see to believe the detail. Mel Ford's Etrich Taube uses warped control surfaces for flight control. Here it makes realistic takeoff.

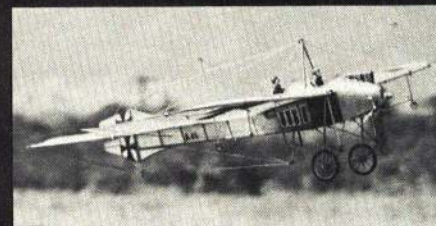



CARL GOLDBERG

The Solid Evidence on CG RETRACTS

Now after more than a year's use by thousands of modelers, we'll bring you each month solid evidence on CG Retracts. Proof of dependability and durability. How they carry heavy airplanes working off of grass fields and last for hundreds of flights. Practical and almost service-free, they work for experts and average flyers—and they'll work for you!



For instance, read what nationally known expert flyer Dave Brown says: I chose CG Retracts over others because of 3 factors: (1) Reliability, (2) Longevity, and (3) Economy. Installed the gear January 1972, using one World Engines S-5 Retract servo to work all 3 units. I fly off of rough

grass a lot, and by March I was putting in 7 or 8 flights practically every evening and, of course, more on weekends. Flew in 20 contests and won 6, including first in C-Expert at the Winter Nationals. My Phoenix 5 now has made more hundreds of flights than you would believe (125 gallons of fuel!), and the gear has given no trouble of any kind. I've never even taken it out of the plane. That's what I call good performance.

Dave Brown

TWIN GEAR Retracts—RG2—\$14.95
TRI-GEAR Retracts—RG3—\$24.95
NOSE GEAR (Only)—RG1—\$10.00

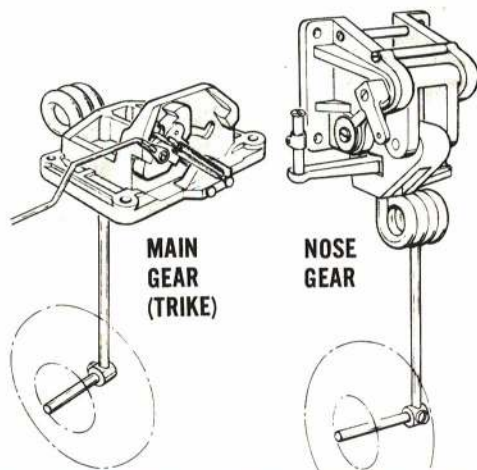

UNIQUE SNAP-LINK! Patent Pending. Now for the first time—you can buy a truly safe link—the SNAP-Link!

- Tiny 45° shoulder snaps through arm, prevents accidental opening. So unique it's Patent Pending!
- One-piece design—no separate pieces that might come apart.

Snap-Link, Regular, with rod SL1 } 29¢ ea
Mini-Snap-Link, with rod MS1 }
Snap-Link SL2 or Mini-Snap MS2 }
less rod 2 for 40¢

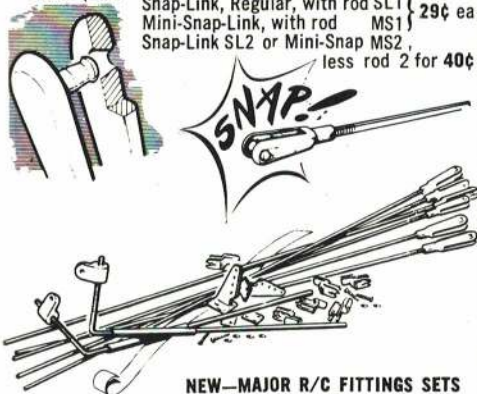

NEW—MAJOR R/C FITTINGS SETS

Here's the economical way to buy the major fittings for your multi-ship. In one set, you get all the horns, links, keepers, bellcranks, or strip aileron linkage, and hinge material—and at a saving. R/C Fittings Set No. 1 for ship with standard ailerons. RFS1 \$3.50
R/C Fittings Set No. 2 for ship with strip ailerons. RFS2 \$3.50

NEW! KLETT PUSHROD EXIT GUIDES

To protect your fuselage and insure smooth operation of your pushrods. Precision made of tough nylon. Easy installation. Large for 5/64" wire, small for 1/16" wire.

PEG-1 LARGE 4 per pkg. 75¢
PEG-2 SMALL 4 per pkg. 75¢

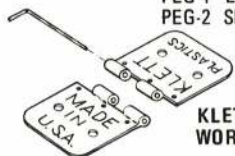

KLETT HINGES — WORLD'S FINEST!

Designed and manufactured by Roy Klett, originator of world-famous RK hinges. An exclusive with Carl Goldberg, these hinges are made with exceptional care and attention to detail. The small RK2 hinges are so thin all you need is a knife slit. The regular size RK3 hinges are the slickest you've ever seen — try holding one leaf and waving the other! And both have removable music wire pins. Ask your dealer for the best — Klett hinges.

RK2-7 7 for \$1.10 RK2-15 15 for \$1.95
RK3-7 7 for \$1.25 RK3-15 15 for \$2.35

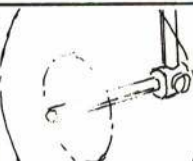

5/32" ADJUSTABLE AXLE

Adjustable axle allows you to easily have the strut length you want. Both the axle and screw are hardened steel. Just file a flat on the strut, and tighten axle in place. AA1 75¢ ea.



STEERABLE NOSE GEAR

Versatile — steering arm can be to either side, or slightly up or down, or mounted on bottom with extra collar in slot. Steering arm is nylon, stiff enough for good control, yet can flex under shock to protect servo. Collar is hardened steel — won't strip like brass. Screw is hardened steel, too. You can really torque it and get good grip on music wire strut without a flat.

Complete steerable nose gear with nylon bearing, 5/32" plated music wire strut, extra collar, blind nuts, screws and washers G16N \$2.50.



NYLON STEERING ARM
Hardened steel collar and screw SA1 75¢.

NYLON BEARING
One-piece design mounts to firewall without alignment problems. Includes blind nuts, screws and washers NB1 75¢.



CONTROL HORNS

Our new horns have the upright part rising from the center of the base for maximum stability. Holes are right size for 3/4" wire; nut plate for simplest mounting. Long horns CH1 or short horns CH2, with screws—50¢/2.



NYLON REINFORCING TAPE

This nylon reinforcing tape is extremely tough when applied with epoxy around the center when joining wing halves. 2 1/2" wide x 5 ft.—N2 50¢. 3/4" wide x 5 ft. N1 25¢.

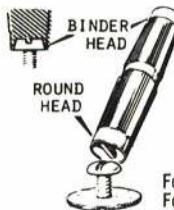

NEW KLETT SAFETY DRIVER
SOCKETS DOWN ONTO SCREW HEAD — CAN'T SLIP OFF AND DAMAGE YOUR WING!
Takes Round Head Screws and Binder Head.

KLETT SAFETY DRIVER

For 1/4" Nylon Screws SD1 } 98¢ ea
For #10 Nylon Screws SD2 }

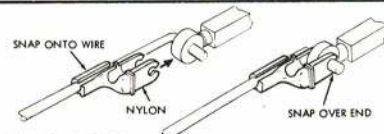

SNAP'R KEEPER

Quickest, handiest way to secure pushrod wire end to servos, horns, etc. Works on wire 3/4 to 1/4" diameter. SK1 50¢ for 4.

REPLACEMENT FOAM WINGS, ETC.

To go with your own design fuselage. Proven efficient Ranger 42 foam wing gets you in the air quickly — \$3.95. Stab and vertical fin, set \$1.95. Assembled Ranger 42 fuselage, plus bearers, nosegear, etc., \$9.95.

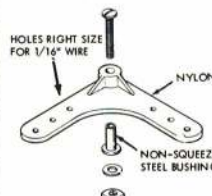

AILERON BELLCRANK

Bellcrank has steel bushing of proper size, so crank can be screwed firmly in place without binding. No electrical noise—all metal parts are screwed tightly together—AB1 50¢ for 2.

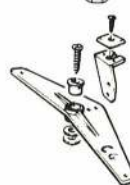

1/2 A BELLCRANK and HORN

Made of nylon, this new set provides smooth 1/2 A control line operation. Easy on dacron lines, too BCh1 25¢.



SHEET METAL SCREWS

Like wood screws, but better. Sharp, clean, full-depth threads, hard and strong. Excellent for mounting servos, etc. Includes washers—#2 x 3/8 SMS2 30¢ for 10; #4 x 3/8 SMS4 30¢ for 8.

P.S. For best service, see your dealer for items you want. If not available, write direct; add 50¢ per item (\$1 outside U.S.). Minimum order \$1.

MANUFACTURERS—All our accessories are available at excellent O.E.M. bulk prices.

Carl Goldberg Models Inc.
2545 W. Cermak Rd., Chicago, Ill. 60608
I am sending 25¢ for 8 pg. Illustrated Catalog with, "Recommendations in Starting in R/C," Basic Explanation of R/C Equipment and Radio Control Definitions.

Name _____
Address _____
City _____
State _____ Zip _____

Available in Canada

CARL GOLDBERG MODELS INC.
2545 WEST CERMAK ROAD • CHICAGO, ILLINOIS 60608

INDOOR MODELING

(Continued from page 12)

This capacity for originality and emphasis on the idea that indoor modeling (all modeling actually) should be fun and a means of expression, almost an art form, as well as a form of competition is what has made Bigge unique among modelers I've known.

Bill's most recent and perhaps most remarkable project has been his Indoor dirigible. This 52 in. long semi-scale airship is based structurally on the British R 100 airship.

The structure of this model, the R-5/8, consists of 14 formers and 16 .036" square stringers cut from Indoor spar stock. The lightweight formers (which Bigge calls "a 16-sided polygonal ring") are built up on a board from short pieces of .036" square stock. Each one of these rings is braced with eight strands of fine dacron monofilament glued and knotted at the center. In building the airship, Bill found it best to start by bending one of the .036" sq. stringers around a full-size outline of the R-5/8 airship, marking the ring locations with a fiber tipped pen.

After marking the remaining stringers, Bill glues two stringers together at bow and stern points and inserts the front and rear formers (oops, "16-sided polygonal rings" if you prefer!). Then the assembly is hung vertically and two more stringers are glued in place. From this point on, construction is relatively simple and similar (in principal) to old lightweight, multi stringer and former, free-flight fuselages. The remaining rings are inserted and the rest of the stringers are glued into place, completing the model structure.

The airship is covered with Micro-lite attached with special Micro-X covering cement. Bill found he could cover almost the entire model with only two pieces of microlite, thus avoiding extra seams which might leak.

When filling the model with gas, it is stood on end with the tail end down. At the tail, a Micro-lite flap is lifted to expose an opening thru which the gas tube is inserted. After filling the model with gas and removal of gas tube, the flap is reattached to film around the opening with tap water.

A note of warning to would-be airship builders, Bill found it most important that the opening in the ship be a good deal larger than the gas tube, to avoid bursting of the model from pressure shock. Also, after a time, provision for air to enter must be made or air pressure could crush the model as the lighter gas slowly diffuses out through the thin covering. Bill also warns that anyone trying to build an airship should weigh the materials as he goes along to avoid an overweight model. Bill's easy solution of this problem is a simple beam balance using a quarter (weight 0.20 oz.) as a standard weight.

The power unit is the one really non-scale item on the R-5/8 dirigible. It consists of an Indoor motor stick and 15-in. dia. prop slung under the bow of the airship. Power is a loop of .040"

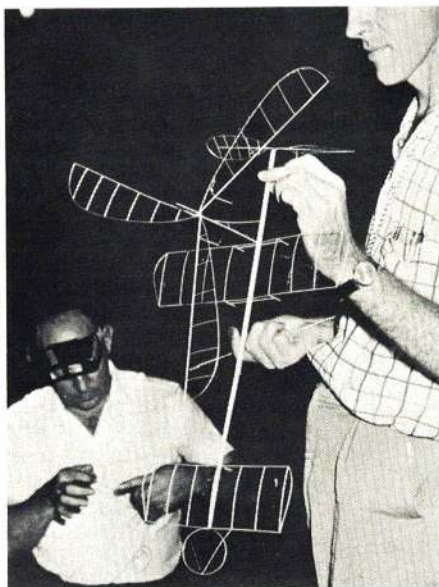

Always interested in the unorthodox type model, here Bill assists John Triolo (background) prepare an autogyro for a record attempt.

square Indoor Pirelli and a forward speed of about two ft. per sec. is obtained on one row of knots.

Flight trim of the model is as follows. A length of thread is attached to the bow and stern of the airship. A small weight is attached to the middle of this thread with enough slack that the weight hangs about three ft. below the ship. This provides longitudinal stability and a realistic flight trim. After filling the model with gas, clay is added to the balance weight until the airship shows slight negative buoyancy (that is, model sinks slowly to the floor). On release after winding, the dirigible climbs slowly and realistically in wide circles and then descends slowly to the floor as power runs out. Watching this remarkable model in flight is a real experience and good example of the almost unlimited fun and creative modeling opportunities to be found in Indoor modeling.

For the technically minded, the hull of the R-5/8 airship weighs .175 oz. of which .093 oz. is wood and 0.78 oz. is Micro-lite covering. The power pod, prop and rubber band would add a total of about .050 oz. for a total model weight of .225 oz. The 52-in. long dirigible has a maximum diameter of 9 3/4 in. and a displacement of about 1940 cu. in. (or about 1.38 oz.).

Along with large amounts of technical data on the model, Bill was kind enough to outline the following design ideas for this model:

"This project was undertaken to show that a scale airship hull (without gas bags), built with standard Indoor techniques and modern materials, could have a reasonable amount of lift in a manageable size. The almost embarrassing lift/weight ratio shows that a model could be successful with much heavier construction, smaller size, or more scale detail. A slightly larger model, perhaps with a smaller fineness ratio, could be radio-controlled. Probably a special

(Continued on page 80)

HOBBY LOBBY

DIGITAL PROPORTIONAL

\$79.95

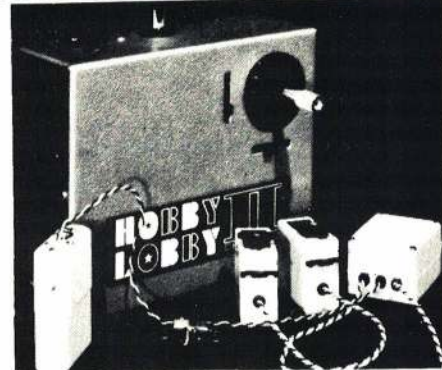

A complete ready-to-fly 2 channel digital proportional system with excellent range for demanding uses such as RC gliders, and with the built-in ruggedness that beginners need.

Outfit includes; transmitter, receiver, 2 servos, battery box and switch harness, 27 mhz. band. Outfit uses dry cells (not included). Add \$6.50 for 72-75 mhz. band.



SENIOR TELEMMASTER

\$49.95

With a 95" wing span this 4 channel behemoth is the largest RC model kit we know of. This is a REAL easy-to-build kit of the finest, lightest balsa wood you'll ever see.

When you get your SENIOR TELEMMASTER all finished you'll have a GREAT BIG monster of an airplane that flies like a tranquilized albatross. It's supposed to use a .40-.60 size engine, but I believe you could keep it in the air with a .19.

DuBro "MUFF'L AIRE" Engine Mufflers
2 types: For Webra 61 only \$7.50
For all engines .29-.60 \$7.95



These highly ingenious mufflers look to me like they may take over the now-complicated muffler business. They have some interesting advantages:

1. By varying the number of baffle plates you can adjust the noise level (and also the exhaust back pressure).
2. The mufflers are small and INCONSPICUOUS on an engine.
3. The \$7.95 muffler has very clever tab device to assure "no drift" alignment on any engine.

EXTRA SPECIAL!

Here's the best deal we've ever offered on a Blue Max Semi-Kit - List price \$265.00

Blue Max 6 CHANNEL Digital Proportional SEMI KIT... \$168⁰⁰

Incredible as it may seem, you can now buy the 6 CHANNEL semi-kit at a discount of nearly \$100 off of its list price! AND the outfit includes 4 FULLY ASSEMBLED SERVOS! Please order quickly because even though this offer is being made during what is a somewhat slack time for radio sales, it is quite possible that demand could outrun supply at this extremely low price.

with 4 FULLY ASSEMBLED SERVOS



Our new 1973 radio is for the RCer who wants the very best, even if it costs him less.

RC MODELER MAGAZINE SAYS... (December 1972 issue)

"Our (Hobby Lobby 5) has performed flawlessly under all conditions and its performance has equalled or exceeded systems selling for twice the price.

... If you want an extremely precise system that will offer you years of reliable service, then we seriously recommend the Hobby Lobby 5 to your consideration."

- Unsurpassed Reliability
- Extremely Long Range
- Smallest, Lightest Servos Made
- Extra servos cost only \$12.00 each.



- I.C. FULL-POWER servo amplifiers
- Full 90 day Warranty—backed by the manufacturer and by Hobby Lobby
- A complete system: Transmitter, Receiver, 4 servos, all n-cads, charger, 27 or 72 mhz.

• PRICE: About HALF of what you'd expect to pay for a top quality 5 channel system.

Series III

HOBBY LOBBY 5 Digital Proportional \$209.

- Improved Airborne Battery pack with ONE-CELL-OUT flight capability
- Only 11½ oz. airborne weight

Please call or write for free brochure.

TRY US OUT: W. B. did,

"Gentlemen:

In my first order from you I received [the radio I ordered] and a refund (\$21.40) that I didn't know I had coming... Needless to say, you could have charged me [the] regular price and I would have been satisfied. So, in my future R/C needs... I'll lean to Hobby Lobby." W. B., Little Rock, Ark.



HOBBY LOBBY BRAND X WHEELS

2" pair	\$1.00
2¼" pair	\$1.15
2½" pair	\$1.30
2¾" pair	\$1.45
3" pair	\$1.55

RC Modeler Magazine
FLIGHT TRAINING
COURSE \$10.00



NEW! Winner of Master's Tournament

Midwest's MACH I
List Price \$49.95
SPECIAL \$37.97

Norm Page's sharp looking pattern ship. 62 in. span, 725 sq. in. wing area for .60 size engines. Kit is conventional balsa fuselage with foam core wing and stab, vacuum formed canopy and wheel wells.



NEW! Midwest's SWEET STIK
List Price \$32.95

and
Fox 40 RC Engine
List Price \$26.95

Sweet Stik is a 54" span, 600 sq. in. brand new sport flying plane. Total list value \$59.90
SPECIAL \$39.97



NEW! Devon "DEV-TUBE" \$1.50
(5 Minute epoxy in 2-in-1 dispenser)

This unique dispenser gives you the same amount of epoxy glue as you get in the \$1.25 size set, but it's in a 2 part syringe-type dispenser. This is not only very handy for field repairs, but is a MUCH faster method of applying epoxy glue. The 2 nozzles are side by side so the ejected epoxy is nearly mixed as it is forced out of the dispenser. You save the time usually wasted in replacing the tube caps, and much smaller quantities of epoxy can be used in each application.



Dremel No. 210 DRILL PRESS \$19.95

Dremel used to have a sort of funky little drill press that didn't turn me on very much. But, this new drill press is a beauty. It doesn't come with a Moto-Tool, by the way, that's just in the picture to show how it works. The drill press takes Models 260, 270, or 280 Moto Tools. The table raises & lowers, and has slots for guides and hold-downs. The drill press is particularly handy in our hobby for routing and grooving.

SPECIAL! Weller
30 SECOND AUTOMATIC
GLUE GUN

List Price: \$11.95 SALE: \$9.97



Halco LANDING GEARS

10.3" tread \$3.80
12.8" tread \$4.25
15" tread \$4.75



Hand-held WIND METER



\$5.95

HOBBY LOBBY ILLUSTRATED CATALOG \$2.00

SPECIAL! SHEET BALSA SALE

Top Quality Balsa from the two largest Balsa Sources

20 Sheets of 1/16" x 3" x 36"	List \$ 9.00	Special \$5.97
20 Sheets of 1/16" x 4" x 36"	List \$13.00	Special \$8.97
10 Sheets of 1/16" x 6" x 36"	List \$13.50	Special \$8.97
20 Sheets of 3/32" x 3" x 36"	List \$11.00	Special \$7.97
15 Sheets of 3/32" x 4" x 36"	List \$11.25	Special \$7.97
10 Sheets of 3/32" x 6" x 36"	List \$15.50	Special \$9.97

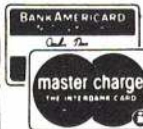

HOBBY LOBBY INTERNATIONAL

Route 3, Franklin Pike Circle, Brentwood, Tennessee 37027 - 615/834-2323

DROP YOUR ORDER IN THE MAIL BOX, THEN JUMP BACK BECAUSE WE SHIP FAST! We pay postage on all orders accompanied by check or money order. Satisfaction guaranteed or money refunded. Phone 615/834-2323 Store hours: 9 a. m. - 5 p. m. except Sundays.

Prospective: RC modeling is supposed to be primarily a hobby—right? A hobby is something to be enjoyed I believe. In fact, life is to be enjoyed to the fullest extent possible. When a hobby ceases to be fun or is a constant source of irritation it would seem the wise thing to try something else. There's an awful lot of uproar lately about the AMA—its aims and policies and its leadership. Lots of people are up in arms on one side or the other. One can see the concern evident in the many club newsletters relative to the furor over the wisdom and justification for dues increases, AMA publications, etc. Charges and countercharges fly back and forth.

I would suggest that the combatants back off from the smoke and fire, clear their eyes and try to weigh the evidence in an unbiased fashion. I realize that this is difficult because I have never seen anyone argue a point except from a preestablished position, and, once the position is taken, the brain is caged and an absolute flood of evidence is required to dent the position. Let's have a little compassion for our fellow man—life is too short without hastening its end with ulcers, heart attacks and the like. The central theme is to enjoy the hobby—right? If you don't enjoy it, forget it.

My friend, Jim Kirkland, enjoyed the hobby. He was firmly committed to his hobby in a very special way which was evidenced by the many contributions he made and the leadership he offered. Jim had great plans for the future and he now would be deeply involved in preparation for next season's Pattern competition except for his untimely death. Jim will be missed because he personified the highest standards of enjoying his hobby—by his capability, his friendliness and willingness to help others. He was a contributor rather than a detractor; he offered constructive criticism where appropriate, but always constructive.

We need a strong and healthy national organization. How else can this hobby thrive? If you don't like some things or want to see change, beat your district vice-president over the head—but be constructive and smile.

Breakthrough: Every now and then some technical advance is made which we call a "breakthrough" or a revolutionary development. When that breakthrough constitutes a substantial increase in capability with a modest investment in cost and complexity it can truly be considered outstanding. Such a development has occurred through the work of Maynard Hill and his co-workers at the Johns Hopkins University's Applied Physics Laboratory. This breakthrough happens to be an autopilot or stabilization system which is easily adaptable to standard model RC systems. The concept can provide one or two axes of stabilization and is all solid state requiring no gyros or moving parts. Maynard has been flying the system for several months.

Through personal contact by virtue of mutual business interests, I have, also, been involved in the development of the concept for its application to military systems. The system can be built to weigh only a few ounces. It can operate on your normal battery supply or on separate batteries. It requires simple modifications to your present servos. Our project group at Wright-Patterson AFB, Ohio has flown the system on five different models, both rudder/elevation control and aileron/elevator. We have flown at night with absolutely no visual reference except a flashing strobe light on the model to track its position. The system cannot be tumbled or fooled. Invert the airplane and it immediately

Autopilot test installation on "Ugly Stick." Note sensors on boom for pitch control. Sensors on wingtips for roll control are "Staticmaster" by Nuclear Products Co.

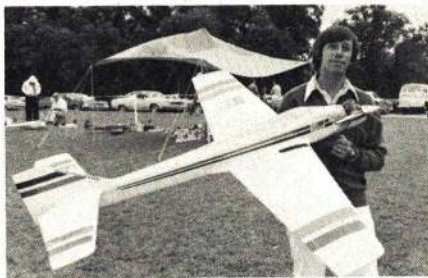

Jerry Worth and his excellent pattern design at the first annual Cedar Rapids Sig RC Meet. Would be nice if more large hobby industry manufacturers could sponsor large meets.

"Valley Flyers," California show variety. From left to right: Dick Sonheim and Kaos, Mr. "X" and Sailer, Earl Hartings and a new Wavemaster, Ken Hall and his new Mini-Master, and Nate Rambo with his original helicopter.



flips right side up when the system is engaged. Hands-off landings have been made in very turbulent winds. Many have flown the system with ease including those with no previous flying experience! Its use as a training device should be outstanding. We are now installing the system on a model helicopter to check its performance. If it works, helicopter operation should become drastically easier. I have flown pattern maneuvers using the system and with proper technique, ten point maneuvers should become easier. Because of this ease of flying I'm sure that the rules committee will need to consider the effect of its use on competition aircraft.

How does it work? It appears to be magic and several Ph.D.s have seen it, heard the explanation and responded: "You're kidding!" As Maynard explains it, sensors are used which measure the atmospheric electrostatic voltage potential. This exists as a vertical gradient and is about 100-150 volts per meter near the earth's surface. The system is mechanized by measuring the potential at each wingtip for roll and with sensors placed on the body or a longitudinal boom with sensors on each extremity to sense pitch motions. When the aircraft is level the potential at each sensor is the same and nothing happens. When pitched or rolled, a voltage differential is developed between sensors which is measured by a differential amplifier. A varying DC error signal from the amplifier is fed to the pitch and roll servos. When the aircraft is flown "through" the autopilot, an "attitude command" is generated and the bank or pitch angles commanded are a function of stick position. In other words, the stick is released, the aircraft returns to level flight. The system can be trimmed in flight using the normal trim controls.

Is your appetite whetted? The concept is still in the early stages of development but initial results have been very encouraging. It has some idiosyncracies that require further understanding but we're working on that. The material that we will present in the future will be essentially a progress report with the idea of encouraging others to get involved and help explore its potential.

AL RABE ON CL

New Format Greater Emphasizes Stunt: In the January 1973 AAM Ed Sweeney published the results of a reader survey. Ed's evaluation of his survey has resulted in the substantial reorganization of AAM, giving the

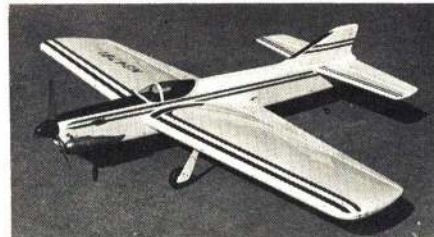

Jerry Pilgrim's original "classic" style stunter is S.T. 46-powered. Placed first in three out of four contests entered and won Expert category at Lexington FAI-AMA Bash in September.

readers more of what they like best. We CL Stunt fliers have profited from this reorganization. AAM is offering us greater emphasis and more space for sharing our views. I agreed to write this column with the understanding that I am not its major contributor. Novice or Expert, it's your column fellows. It's a place to share ideas and techniques, a forum for thoughtful discussion, a place to air your gripes and suggest methods of improving our lot. Send your ideas, sketches, photographs, etc. to me at 1904 Valley Oaks Court, Irving, Tex. 75061. (Telephone: 214-254-5096.)

I think Stunt fliers deserve a good thought-provoking column. If you don't care to help me achieve it, I promise to step down and give someone else a chance.

Rules: Last year the CL Contest Board added a set of guidelines for appearance judging to our AMA Stunt rules. Personally, I would like to see these guidelines removed. I am not convinced that competent judges need or use them.

If we can't muster enough support to have them taken out, then they should be modified. I refer, in particular, to the author's definition of "originality." I'm afraid that I don't understand why a semi-scale airplane can't be original. The use of lines or shapes derived from full-scale aircraft seldom improves a model airplane's ability to perform a Stunt pattern. In fact, the use of shapes and configurations which differ substantially from "Classic" designs usually work to the detriment of semi-scale stunt ships. Virtually every line and shape of the original must be altered either subtly or radically to increase the semi-scale airplane's performance.

I think that "originality" should somehow be redefined to include (but not be limited to): multi-engines; fat or skinny fuselages; unusually long or short nose or tail moments; high, low, dihedral, anhedral or gull wing configurations; canard or biplane configurations; high or low aspect ratios or elliptical wings; retracting or shock absorbing landing gears; "T" tall or "V" tail configurations; aerodynamic innovations such as turbulators, boundary layer control, variable ratio controls, leading edge devices and workable gimmicks of any description; construction innovations such as molded balsa or plastic fuselages, new or improved uses of foam and fiberglass internal mufflers or exhaust ducts; and the use of new or unusual powerplants.

In short, "originality" should be practically anything which is creative, innovative or differing substantially from traditional CL Stunt practices. There should be more to "originality" than a new set of outlines on a

(Continued on page 102)

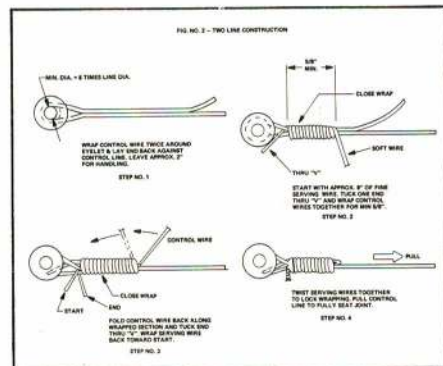



CAJUN QUEEN

We don't know if the name for the plane came before Lou found the decal or after, but the plane flies like a graceful beautiful lady. It was the colors that attracted AAM's attention to the model for publication. Watching her fly at the Nats, she was so smooth and effortless. Oh yes, ask Lou where to get the decals. Article starts on next page.





This is the retract equipped version of the Queen. That air scoop below the engine gives ample space for the nose gear unit and access to its mounting bolts.

Cajun Queen? Wondering what it is? Well, looking it up in the dictionary you'll find that "Cajun" refers to a very special group of people of French descent that predominantly reside in the Gulf Coast States. A more hospitable or friendly people you will never meet. Queen means the same in any language—a gracious, beautiful lady. I like to think that this describes this airplane exactly.

When I first started thinking of this airplane, I wanted a plane that would perform in windy weather but wouldn't be a dog in calm weather. Being a genius in aerodynamics, I decided I'd better stay with the proven airfoils and moments of other airplanes. The wing root section is 15% symmetrical tapering to a lifting tip. The first planes were 650 sq. in. with fixed gear and 6½ to 7 lb. but with retracts and FAI Pattern (and weight requirements) the wing was increased to 680 sq. in. Most of the planes have been 7¼ to 8¼ lb. and handled really well in the wind. The stabilizer, which is Diamond airfoiled, does two things. It increases the amount of drag at the rear of the plane which decreases the tendency to tail waggle and also lets the elevator be soft around neutral.

Now for some Balsa Butchering. To start with, select some light fuselage sides. Cut the 1/32 plywood fuselage doubler F-10 and glue them to the fuselage sides. While these are drying, cut out all the remaining parts. Glue

Well proven features and easy handling in any kind of wind make this a frequent Class C or D Pattern winner.

LOU PENROD

1/32 balsa doubler F-10 A to fuselage sides, glue 1/4 balsa doubler F-11 to fuselage sides, glue 1/16 plywood F-12 to fuselage sides, glue 1/4 balsa doubler F-9 to rear of sides being sure to leave room for the 1/4 sq. on the bottom. Now glue the top and bottom rear 1/4 sq. longerons to fuselage sides; at this time you can glue the 1/8 x 1/4 cross bracing to the sides.

To assemble the fuselage you need a good flat surface. This step is one of the most important steps in building any airplane. If you don't have a building jig, take 1/4 plywood or hard balsa and make eight vertical side braces. These braces have to be exactly square. Now position the sides over the plans with F-2 position just off the building surface. Starting with F-2, glue F-2, F-3 B F-6, and F-8 between the sides. Using the vertical braces at all former locations, align the sides so they are exactly square. Take your time with this and your fuselage will be true. After this has

dried, pull the tail together and glue inserting a 1/2 in. wedge between sides.

Now install F-13, F-16, F-14 and 1/4 sq. cross braces; after it has dried, remove the fuselage from the board and with epoxy completely paint the tank compartment. Now add top formers F-3A, F-4, F-4A, F-5, F-6A, F-7, and F-8A. Sand the taper into the fuselage top sides to accept the 3/8 sheet balsa for the turtle deck. Glue the two 3/8 sheet balsa sides into place; when dry, sand the top down to the formers and add the top 3/8 sheet. Glue the nose block in place and carve the top to shape. Now install the 3/32 balsa bottom rear fuselage. Glue 3/8 sheet to bottom front adding the triangle stock between F-13 and F-3B. Add F-1, F-1A and carve scoop and turtle deck to shape. Sand complete fuselage. The rudder is conventional built-up with 1/16 sheet on each side of the ¼ stock. Be sure and glue the dorsal fin and rudder onto the vertical fin before sanding to shape.

Now for the wing and stab. The cores are easy to cut, but if you can't cut them, they are available through Mercury Hobby Distributors of New Orleans, Louisiana. Cover the wings with as soft a balsa as you can purchase, being sure not to get the panels mixed. (The lifting tip doesn't work too well upside down!) Install the trailing edge of the stab; then cover with soft balsa, using eight pieces and keeping the high

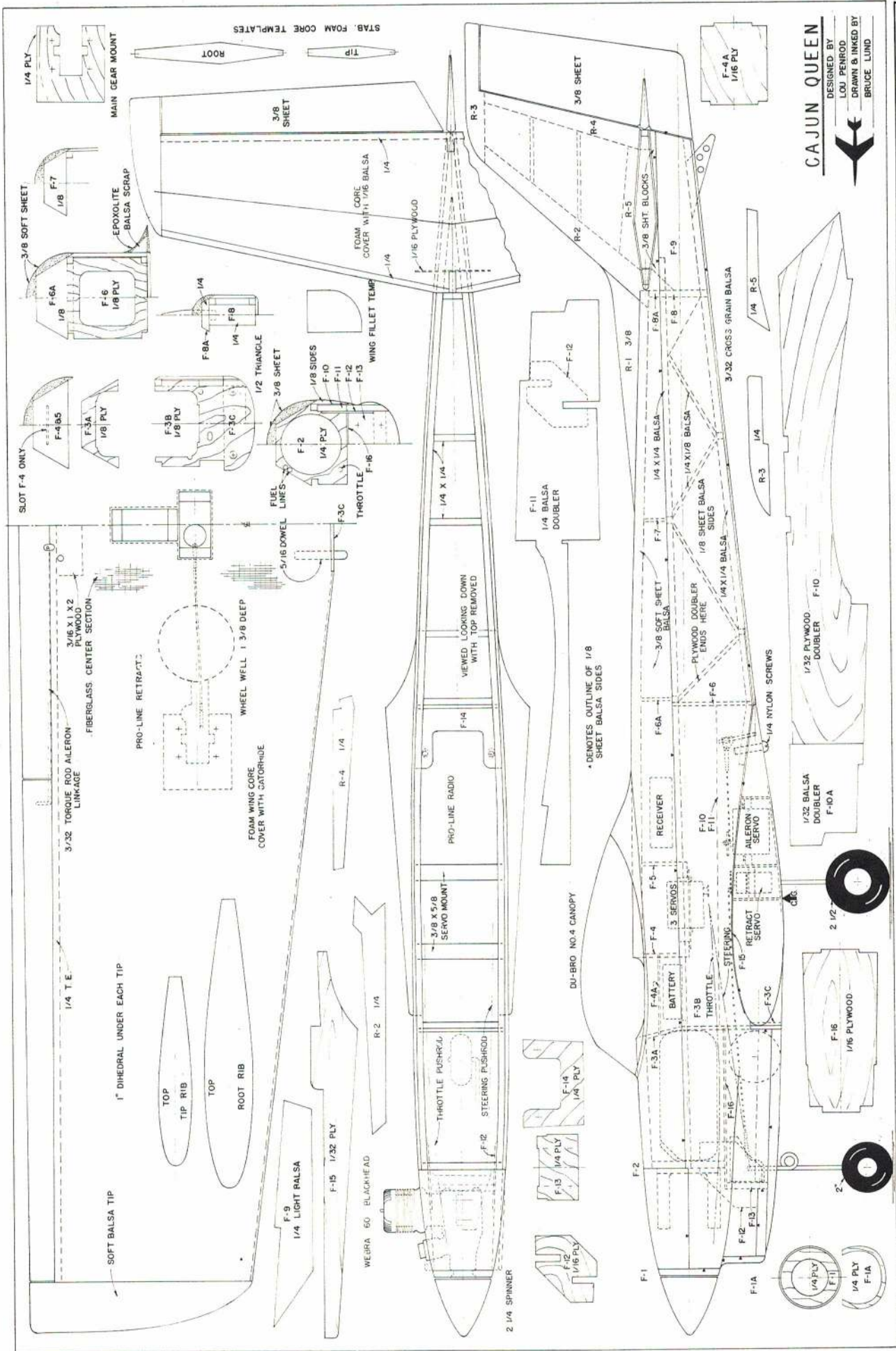

CAJUN QUEEN
 DESIGNED BY
 LOU PENROD
 DRAWN & INKED BY
 BRUCE LUND

FULL SIZE PLANS AVAILABLE - SEE PAGE 84

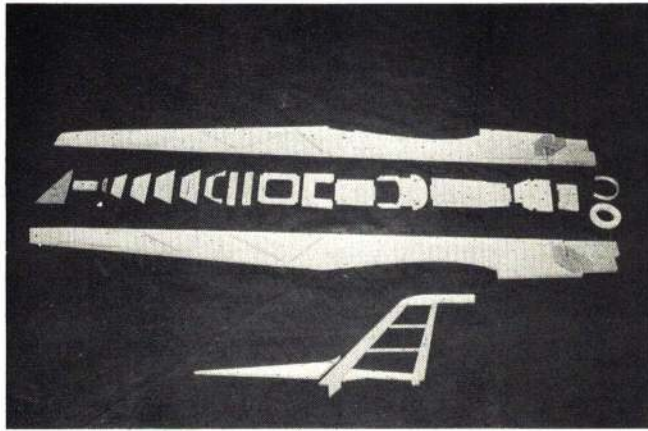

Cut all these parts and assemble the sides and bulkheads first.

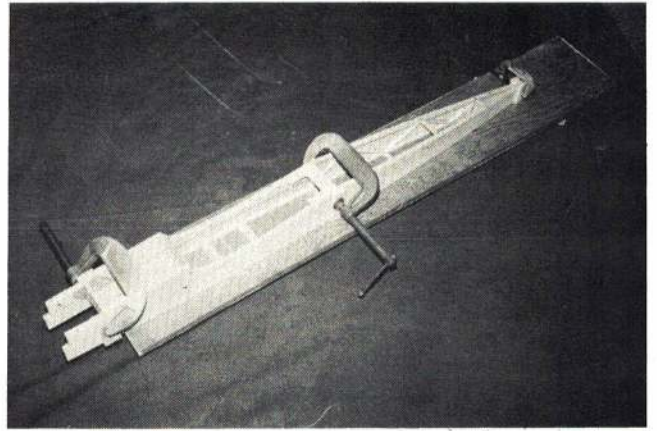

On a flat surface start fuselage assembly. Text recommends procedures that assure a true plane throughout, but without a jig as such.

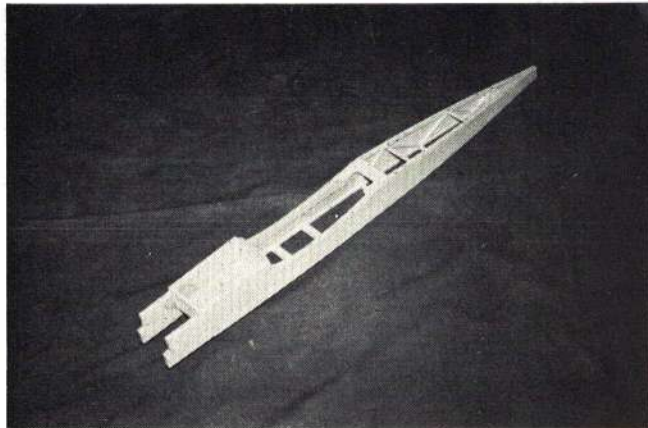

Here's the basic frame. Note generous compartment for the nose gear and the "U" shaped plywood wing attach piece.

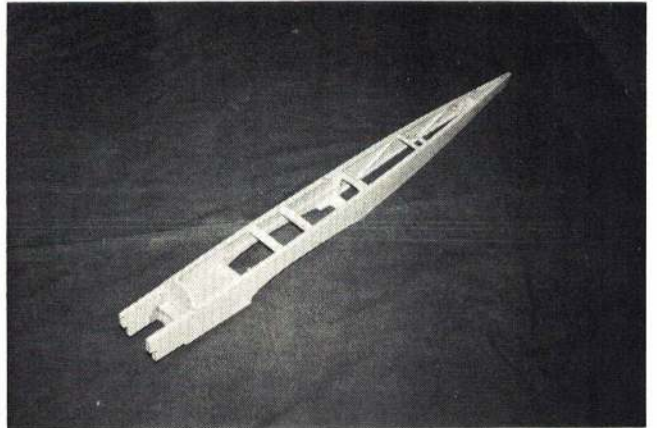

Turn it over for shaping the top deck, canopy area, etc. That diagonal bracing at the rear adds strength without lots of weight.

point of the diamond constant. After dry, add the leading edge, tips and elevators and sand to shape. Break the point of the diamond with the sanding block just enough to give a small radius.

Join the wing panels and add tips, aileron horns and linkages, aileron and wing center sections and F-3C. Sand to final shape and add fiberglass over center section. Install 5/16 dowels and drill holes for 1/4 nylon bolts. Put the wing on the fuselage and make sure it is going to fit the saddle, checking to make sure there is no incidence and that the fuselage is square on the wing. Use a string and go from the center of the fuselage over the wing to each tip making sure it is equal, then measure from the tail to each tip to make sure it is square. Holding the wing in place, add the wing fillets making certain they contour exactly with the wing. Make the stab seat and install stab, being certain of no incidence and, using the string again, align stab. Install rudder again using string to make sure it is square.

The only retracts I have used are Pro-Line, CAS, and MK. But all three were no trouble to install. You can cut the wheel wells and install the landing

(Continued on page 81)

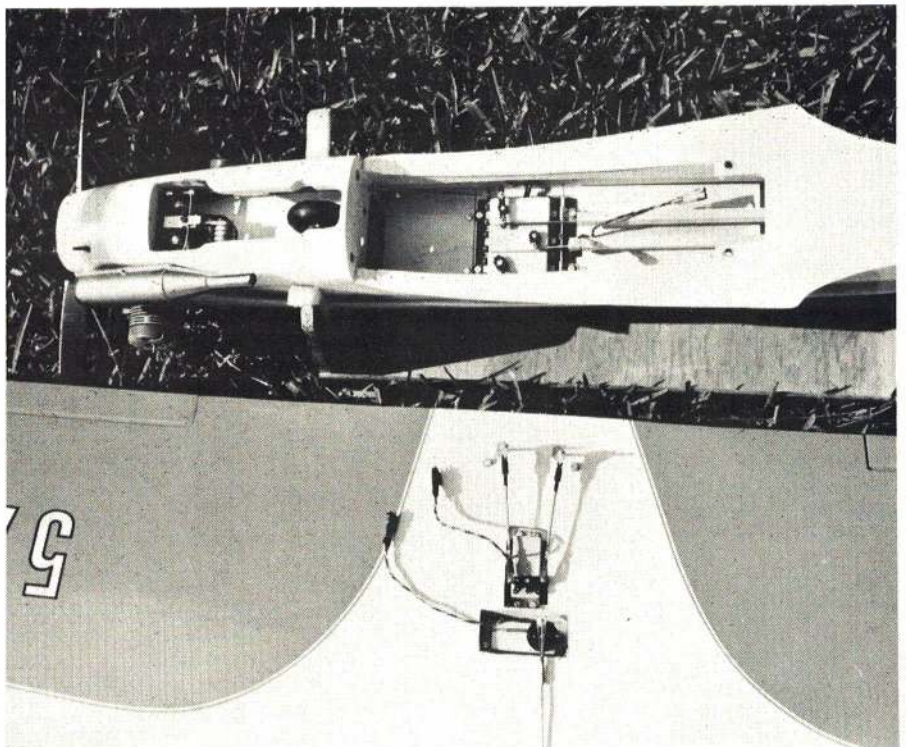

Only three servos in fuselage. Wing has aileron servo and one 180 degree servo for retracts. Note use of Du-Bro link and its brass fitting for nose gear hook-up. Simple.



TOWER HOBBIES

P.O. BOX 2874 STATION A • CHAMPAIGN, ILLINOIS 61820

PHONE 217-356-4294

SOARING

AIRTRONICS:		
Olympic 88-99	Reg. \$34.95	ONLY \$28.00
Mini-Olympic	Reg. \$19.95	\$17.00
Questor	Reg. \$26.95	\$21.50
Grand Esprit	Reg. \$99.95	\$77.50
ASTRO FLIGHT (AFI):		
ASW 17	Reg. \$55.95	\$43.50
Monterey	Reg. \$29.95	\$21.00
Malibu	Reg. \$22.95	\$17.50
Fournier RF-4	Reg. \$29.95	\$21.00
MARK'S MODELS:		
Windward	Reg. \$25.95	\$19.50
Windfree	Reg. \$34.95	\$24.50
GRAUPNER:		
Cirrus	Reg. \$60.00	\$39.00
Cumulus	Reg. \$135.00	\$92.50

POWER

BRIDI:		
RCM Basic Trainer	Reg. \$27.95	ONLY \$22.00
RCM Trainer	Reg. \$44.95	\$35.50
Kaos	Reg. \$49.95	\$39.00
TOP FLITE:		
P-51 Mustang	Reg. \$45.00	\$30.00
P-40 Warhawk	Reg. \$49.95	\$33.50
Kwik Fli IV	Reg. \$45.00	\$30.00
Contender	Reg. \$34.95	\$24.75
GOLDBERG:		
Falcon 56	Reg. \$19.95	\$13.95
Senior Falcon	Reg. \$36.95	\$25.50
Skylane 62	Reg. \$36.95	\$25.50
Skylark 56	Reg. \$22.95	\$16.75
VK:		
Curben "Super Ace"	Reg. \$32.50	\$22.50
Navajo	Reg. \$39.95	\$27.00
Cherokee	Reg. \$39.95	\$27.00
Cherokee Babe	Reg. \$27.50	\$19.25
Nieuport 17	Reg. \$44.95	\$31.00
Fokker Triplane	Reg. \$47.95	\$33.00

HELICOPTERS

RC HELICOPTERS INC. BELL JET RANGER	
Retail \$475.00	Only \$395.00
HEGI BELL HUEY COBRA	
Retail \$350.00	Only \$300.00
KALT BELL HUEY COBRA	
Retail \$370.00	Only \$315.00
MRC-KAVAN BELL RANGER	
Retail \$400.00	Only \$325.00
DUBRO WHIRYLBIRD 505	
Retail \$125.00	Only \$87.50

SUPER Monokote

6 FOOT ROLLS

<p>OPAQUES: Red, White, Orange, Yellow, Clear, Aluminum, Gray, Blue, Dark Blue, Black, Chrome, Olive Drab</p> <p>ONLY</p> <p>Retail \$8.10 \$5.00</p>	<p>NO MINIMUM NO LIMIT!</p>
<p>TRANSPARENTS: Yellow, Orange, Red</p> <p>Retail \$9.00 \$5.60</p>	
<p>METALLICS: Plumb crazy, Green, Blue</p> <p>Retail \$10.50 \$6.50</p>	

SOLARFILM

6 FOOT ROLLS

OPAQUES: Dark Red, Bright Red, Dark Blue, Light Blue, Orange, Yellow, White, Black, Silver	
ONLY	
Retail \$6.60	\$4.50
TRANSPARENTS: Yellow, Orange, Blue, Red	
Retail \$7.50	\$5.00
METALLICS: Green, Gold	
Retail \$9.00	\$6.00

"POLYTHERM" ELECTRIC HEAT GUN

**** A Must For Monokote & Solarfilm ****

- Adjustable Flow
- 1000 Watts of Heat
- Focused Heat Beam



Retail Value \$36.00
ONLY \$28.00

DEVCON EPOXY

"5-MINUTE"

Small	1 oz.	\$.90
Large	2.5 oz.	\$1.60
Giant	16 oz.	\$6.50



NEW!!

→ "ZIP-GRIP" 10 Epoxy Will Support 5000 Pounds Per Sq. Inch. Only \$2.00

A-justo-jig



FUSELAGE ADAPTOR
Retail \$10.00
Only \$8.00

FULL - HOUSE
Retail \$45.00
Now Only \$37.00



SEALECTOR SEALING IRON



→ Adjustable From 300°F To 550°F

DELUXE MODEL
Retail \$12.95
Only \$10.95

DELUXE MODEL WITH RUBART SUPER SHOE
Total Retail \$15.93
Only \$12.75

*** TOWER INDUSTRIES *** ON DISPLAY AT TOLEDO CONFERENCE

1.2 VOLT NI-CAD BATTERIES

Government Surplus



Excellent Starting Batteries!
→ Choose From 4 Sizes

2 Ampere Hour	\$3.40
4 Ampere Hour	\$4.95
7 Ampere Hour	\$6.25
14 Ampere Hour	\$7.95

HELICOPTER CONVERSION PACKAGES

- Convert Your Hegi, Kalt or Bell Ranger to Electric Motor Power. Fly Inside Your Own Basement Without Noise or Exhaust.
- Convert Your Dubro 505 to Ross Twin Power. Complete Packages.

*See these at Toledo, or write for brochure

SATISFACTION ALWAYS GUARANTEED AT TOWER HOBBIES!

C O D PHONE ORDERS



CALL 217-356-4294

Until 9:00 p.m. For Immediate C.O.D. Shipment. Call Today - Build Tomorrow!

HOW TO ORDER BY MAIL

Add \$1.00 to each order for Full Insurance, Postage, and Handling. Money Order or Check only. Alaska and Hawaii add \$5.00 Foreign Orders add \$10.00.



NEW SPRING '73 CATALOG

Over 60 Manufacturers at the Lowest Prices Anywhere! Send 25c in stamps or coin.

FREE WITH ANY SIZE ORDER



MACCHI C. 202

In our search for the all-around airplane, we find that it must meet the requirements of being inexpensive and easy to build, and its flying capabilities must be in the full stunt range. The low-cost factor can be obtained by designing the model around a 19 engine. But after testing several present kits, it was found that this size of airplane flies more like a brick. The kits seem to lack sufficient wing area to achieve a flyable wing loading. We therefore designed the aircraft with double the area of kit planes, yet almost the same weight. Now we had only to achieve the right configuration, as scaled-down full stunt ships' moments were not usable.

After having designed several models to meet these requirements, all with only limited success, a member of our club, Dick Oglesbee, brought out a new aircraft for the W.A.M. "A" Stunt event. This plane came close to what we wanted. Using it as a starting point, we enlarged and generally redesigned it into the plane presented here—the Macchi C. 202.

The Macchi has been so successful that the fuselage and wing tips have been changed by various club members to produce such variations as an Me 109, a P-47, a Boulton-Paul Defiant, and more. We use ours for sport flying and practicing the stunt pattern. It is also a real crowd pleaser when used in Slow Combat. The Macchi is an excellent plane with which to learn the A.M.A. stunt pattern. If you are ready to begin stunting, try one!

For practicing the pattern here's a sort-of-scale profile job for 15 to 25 size engines. It is also popular in the West Coast Class A Stunt event.

SCOTT A. CONRADSON

The Macchi has flown competitively on engines from a 15 up to a 23. I would recommend an O.S. 19, or, for a really hot ship, a Supertigre 23. The new Fox 25 is also good. The advantages of using an "A" size engine are many. It costs about two thirds of an equivalent 35 to buy and run, and the cost of the aircraft is also less. The main reason that such a small engine can effectively power an aircraft as big as a Ringmaster is the plane's light weight. Therefore, wood selection is important. All wood should be firm, light "C" grain balsa (the balsa that is speckled), except for the planking, which should be "A" grain (the wood with long grain marks that bends easily). The airplane can be modified to suit individual tastes. Do not change the moments or airfoil, but try your own original fuselage outline drawn over the plans. This is a good way to begin learning how to design your own. Besides, it's fun to take your original design out to the flying field.

Construction

The piece of wood used for the fuselage is the most important single piece in the entire plane. It must be firm, very light "C" grain. If you cannot find a good piece of 1/2" balsa, then use a 3/8" piece. Trace the fuselage outline onto it, and cut it out. Do the same for the 1/8" ply fuselage doublers and the 3/8 x 1/2" hardwood engine mounts. Epoxy the engine mounts in place; then epoxy on the doublers. When they are dry, use a block plane to plane the fuselage to an oval cross section. This step will lighten the aircraft considerably, and is a must for optimum performance.

Trace the rib outline of the wing on a piece of 1/8" plywood, and cut it out. Now cut 19 8 x 1 1/2" rib blanks out of 1/16" "C" balsa. Take a few of these at a time, stack them behind the plywood pattern in a vise, and file them to shape. Split a piece of 3 x 36 x 1/16" "C" balsa for the trailing edge. Place a sheet of plastic over the plans and pin the trailing edge down in place. *Do not* use wax paper, as this weakens the glue joint.

Mark the place where each rib will go on the 1/8 x 3/4 x 36" "C" main spar, and place the ribs on it. Glue the ribs in place on the trailing edge. Glue on the top of the trailing edge, the cap spar, and the leading edge. Glue the ribs to the main spar.

Rig up the bellcrank with leadouts and pushrod. Bolt the assembly to the 1/8" plywood bellcrank platform.

(Continued on page 72)

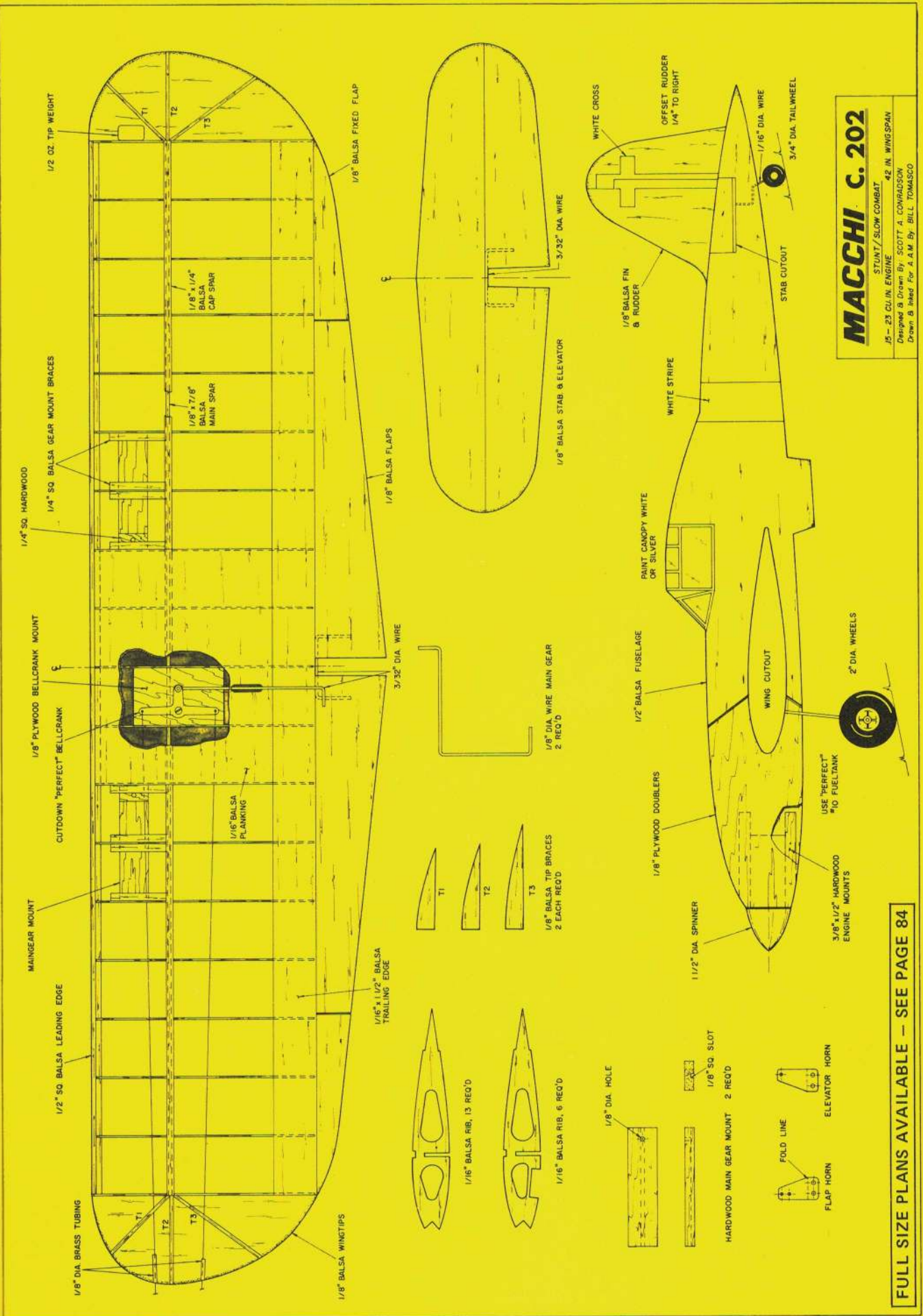

MACCHI C.202
 STUNT / SLOW COMBAT
 19-25 C.U. IN. ENGINE 42 IN. WINGSPAN
 Designed & Drawn By: SCOTT A. CONRADSON
 Drawn & Inked For: A.A.M. By: BILL TOMASCO

FULL SIZE PLANS AVAILABLE - SEE PAGE 84

FRED MARKS ON RC

Answers to AAM Commander Queries: We shall take time this month to answer a number of the most frequently asked questions from readers regarding the AAM Commander series of articles and present some errata for the articles.

As we said in the series, the following would be forthcoming and they will be over the next few months. Please be patient, writing to ask doesn't speed the process. A one to eight channel decoder has been completed, the drawings are complete. All that remains is to write the final text. A P.O.D. has been designed and tested but drawings and text must yet be completed. We have decided to skip the four channel transmitter for now and concentrate on a matching seven channel transmitter which uses the same IC as the decoder. This is working on a bread-board but must yet be laid out on P.C., drawings made, and text written. Please don't expect advance information. If we had it completed it would be ready for the magazine. That makes sense doesn't it? We cannot present the 72 MHz receiver in the magazine because the receiver must receive FCC type certification at considerably more expense than I am willing to bear. However, ACE R/C plans to have the certification done at a future date.

A few people have run across Furuichi 11 ohm motors for which the internal connections were reversed. Frustration! This can easily be checked as follows: If the servo can be made to null (motor stops) at the proper feedback pot location, with the servo gear disengaged from the gear train, but runs to one end when the gear is engaged, you have the problem. Solution: Reverse the motor connections from the servo amplifier.

Can servo travel be changed to accommodate transmitters which have a pulse width change more or less than plus or minus 0.5 milliseconds? Yes. Increase the value of R8 (now 3300 ohms) to decrease travel and vice versa. In extreme cases C6 may be varied in conjunction with changes to R8 to give an even wider range of adjustment.

The servos hum too much or jitter. The World Engines IC in conjunction with the D&R mechanism makes a fast servo so conditions must be maintained properly. The wiper and surface of the pot should be coated very lightly with silicone grease. This grease is available from ACE R/C. Their kit systems already have the grease applied. Contact must be maintained between the wiper and the pot; be sure the wiper is contacting the pot element. Because the servo has such high resolution, in some instances, it may jitter. Home builders may find it desirable to increase the value of R4 and R5, as pairs, from 15 ohms to 33 ohms. Others have reported changing R2 and R3 as pairs to values as low as 33K rather than 47K. In either case, servo resolution suffers very little.

About the servo IC—Although we cautioned the builder in the servo article to be cautious in connecting power to the servos, some have still made the mistake of reversing connections or of shorting the outputs to the motor to ground. I know—I wiped out two ICs with one dumb reversal. Y'all be careful!

Servo centering—Don't be lazy in centering the servo before attempting serious operation. There is a stop pin which prevents over-rotation but it doesn't do the servo much good to drive it against that stop.

In some cases, a transmitter modulator has failed to function. Although this did not show up in the four prototypes and ten pilot units, it occurs when an expander (MC885P) is encountered with higher than desired leakage. This is cured by reducing R7, in the encoder, from 82K to 56K. At the same time, C7 should be increased to .05 microfarad to retain the proper pulse expansion prior to the modulator.

Will the AAM Commander receiver operate other decoders, for example the MAN 2-3-4 decoder? Answer: The Commander receiver produces negative-going output pulses. If your current receiver also produces negative-going pulses, chances are it will work. If not, adding one transistor to invert the pulses will permit an interface.

What is a "modern" digital transmitter? Apparently, we confused some folks with that statement. Please accept apologies. The airborne unit will function properly with a digital transmitter which has the following char-

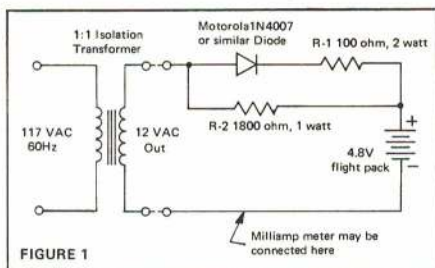

FIGURE 1

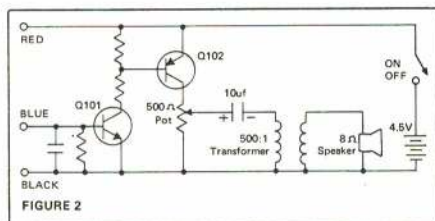

FIGURE 2

acteristics: (a) The same RF frequency. (b) Uses a modulation and encoding technique which amplitude modulates the RF signal with a pulse ranging from 250 to 350 microseconds wide at intervals of 1.5 milliseconds for each channel with a pause between frames of at least three milliseconds. Please refer to Part II in the May 1972 issue for terminology and description. In plain language, this means any digital transmitter that I can recall. There are three that I know of for certain that won't work because they are, in fact, not digital in the preceding sense. These are the Jerobee car radio, the first series of Kraft KP-2B radio, and the old ACL Digilog sets.

Are the Commander servos compatible with my (numerous) receiver? Answer: Perhaps. If the decoder output pulse is positive-going, however, we can verify this only for the Heathkit GDA-47 with which we have successfully mated them. If you choose to try them please let us know the results.

Can't find "carbide" drills, there is no such thing, etc. Forget it. Go to a dentist supply house and purchase one KERR BURR FG 1/2 dental burr or its equivalent. If you can't find a dental supplier, hit up your dentist for an old burr. These will drill a lot of boards.

Figure 1 of the transmitter article has an error. In the fifth paragraph it states "the actual transmitted envelope is a continuous wave at the desired RF frequency separated by T1 and T2" should end "separated by T2 and T3." On Figure 2, there is a typographical error in that the statement "G3 through G7 are IC-2" should read "G5 through G8 are IC-2." The reader should also note that G4, G8, and E4 are not used.

One reader questioned the purpose of the blank square beneath L7 of the transmitter. The reader will note that as little copper is removed from the board as practical, therefore the particular square is left to minimize the amount of copper to be removed by etchant.

The receiver text of Part III, refers to Q1 in some places as the mixer then switches correctly to Q2. All references to the mixer should be as Q2. Q1 is the local oscillator.

Mitsumi IF cans were suggested as a possible alternate to the TOKO IF cans and they will work. However, tuning is extremely difficult and occasional problems of instability have since been encountered with them. We therefore suggest they not be used.

In setting type for Part III—Receiver and Decoder—the "bar" was inadvertently dropped from Q-bar (i.e., Q) in describing the decoder. The description may be corrected as follows: Each time that Q appears in a pair, for example as "Q and Q" or as "whenever Q is positive, Q is negative," the second Q is actually Q-bar. The only exception to this occurs in the second paragraph of the center column of page 51 wherein the sentence should read "So, as soon as Q for FF-1 is a one, FF-2 is set and free to shift to Q when it receives the second pulse, which also returns FF-1 to Q-bar."

On the receiver overlay, item No. 59 is mistakenly labeled C-11 and should be C-22. The connection for the positive end of C-25 should be moved to the junction of R23 and

R24 on the overlay. The schematic of the receiver is snarled at that point with the following two changes required: The plus end of C-26 connects to the junction of R22 and K23. The plus end of C-25 connects to the junction of R23 and R24. None of the preceding really change receiver performance. We just wanted it to be technically correct.

The transmitter oscillator coil L5 should be wound from No. 26 hook-up wire, not No. 22. This is the 19-strand hookup wire used extensively in RC sets.

R-18 on the transmitter schematic should be in parallel with C-14, that is, between the two dots in the solid line immediately to the left of C-14.

Connection to the divide preceding inverter No. 4 of the decoder should be at the junction of inverters No. 2 and 3, not at the junction of inverters No. 1 and 2.

BOB HATSCHKE ON FF

Torque vs. Torsion: As Winnie the Pooh might have put it, torque is A Good Thing. Torque makes propellers go 'round. And this makes the prop pull (or sometimes push) a free flight up into the air. The more torque applied to the prop, the more it pulls, and the higher the model gets—presuming it's in trim.

Torque also puts a twisting load on the prop shaft, usually called torsion. Torsion can be A Bad Thing, because it's trying to twist the prop shaft in two.

All of this is true whether the source of the torque is an internal combustion engine or twisted-up rubber seeking to release its stored energy. Engine designers pay careful attention to the size, shape and material of which crankshafts are made so they won't shear off under the torsional loads imposed. Rubber model designers are not always so careful, probably because the music wire we use for prop shafts is an extremely high-strength steel, and we have witnessed very few failures in the many decades we've been using music wire for prop shafts. But some of us are pushing our luck!

An outstanding rubber job was presented in the pages of AAM last year, but analysis of the shaft design shows marginal strength. It called for a prop shaft of 1/8" music wire with both ends heated to cherry red, then air-cooled, then turned down to .11" dia. and threaded 4-40 on each end. Heating and air cooling is a process called "normalizing," which is done to soften the steel so it can be threaded with a die. Normalizing weakens the steel (which is its purpose to allow it to be cut by the die) and then cutting 4-40 threads further reduces the diameter (at the thread roots) to .081", or just over 2 mm.

Generating the torque and the torsion in that model was a 16-strand Pirelli motor wound up to a maximum torque of 105 in.-oz. Converting this to in.-lb. and using it in the standard formula to determine stress in a solid, round bar: $\text{stress} = \frac{16 \times \text{torque}}{\pi \times d^3}$

that the steel shaft is stressed to approximately 63,000 psi (pounds per sq. in.) at the root of the 4-40 threads.

Looking up the strength of music wire in an engineering handbook, we discover that it has an ultimate strength in torsion in the range of 150,000 to 300,000 psi, and a yield point in torsion in the range of 90,000 to 180,000 psi. Yield point is the significant number, since that is the stress required to put a permanent twist in the wire. Also, it is a fact that smaller wire tends to have the higher strength (in terms of psi), and we're using 1/8" stock, which is fairly large. So the lower value of 90,000 psi is more realistic. Further, that value is the torsional yield point for music wire that has been patented (a complex heat-treating process) and cold-drawn to produce high strength—not normalized. Also the stress calculation did not take into account the vectorial addition of tensile loading, any bending moment due to offset thrust, not the fact that a cut thread generally produces stress concentrations at the root. It's true that these values would not increase the stress by very much, but they certainly don't reduce it.

There's no way of telling how much strength the wire lost by being normalized, but it's a good bet that the final yield point is

(Continued on page 104)

e re-
ow-
l of
and
the
pre-
We

ould
No.
used

ould
the
the

ver-
the
the

ooh
ing.
this
n) a
que
the
rim.
the
can
wist

of
e or
ered
ion
ich
off
ber
ful,
for
gth
ures
usic
sh-

ted
s of
. It
vire
air-
and
air
g,"
be
the
cut
ads
ead

in
tor
in-
in
n a
ind

oxi-
the

e in
t it
the
eld
to
ant
to
is a
her
ing
ver
er,
for
lex
ro-
the
unt
ny
the
ces
nat
by
it.
ich
ed,
t is

!)



SEA FURY

Length44 inches
Wingspan . . .60 inches
Weight73 ounces
Power S.T. 60
Designer Al Rabe



Photos by Al Rabe

THE 1972 STUNT WINNER

GO FOR BROKE

Little did I realize a year and a half ago as I sat studying the FAI rules that 1971 was going to be a "go for broke" year. At that moment I was feeling helpless frustration. It was an FAI qualification year and, according to the rules, mufflers would be required. I think most stunt fliers dread the thought, initially at least, of using mufflers as they add weight, rob power and cause cooling problems without improving, in any way, an airplane's ability to fly a pattern. I was particularly upset as my semi-scale Mustangs and Bearcats tended to build heavy. Also, for optimum performance, even the lightweight Bearcat III needed all of the power that an ST 46 could offer. Since my current airplanes could afford neither the weight nor power loss of a muffler, clearly, a new airplane was needed, designed to FAI rules.

Because of the power loss, this new airplane would either have to be smaller to use the very fine ST 46, or about Bearcat size with a larger engine. In general, Bearcat size airplanes have a slight advantage over smaller airplanes because of slightly more favorable Reynolds number and usually a somewhat better visual impression. I therefore decided to build the Bearcat size airplane and use the lightest 60 available having the necessary conservative porting and reasonably long stroke. This narrowed the choice to the ST 60 at 12 ounces (with venturi, not carburetor).

Most controversial stunt model is full of new construction techniques, up-to-date aerodynamics, engine/muffler ideas, and ample trimming capability.

AL RABE

The extra weight of a heavier engine, larger tank, extra fuel, muffler and stronger nose structure dictated that my new stunt ship should have a short nose and could possibly profit from a longer than normal tail moment. After spending a few hours looking at Green's *Famous Fighters of World War II*, I found several airplanes which would make excellent semi-scale stunt ships by profiting heavily from the above-mentioned nose and tail moment changes. The Spitfire and Hawker Tempest V seemed the most ideal with the Tempest V having the edge because it offered the possibility of enclosing the muffler within a large "chin" radiator. When I drew up the Tempest V, the nose was so large that the ST 60 cylinder head didn't even extend into the "chin" radiator area. As a matter of fact, at that scale, the engine and muffler would go into the radial cowling of the more attractive Tempest II. From

there I couldn't help but notice the Hawker Sea Fury which has the same wing and cowling as the Tempest II, better lines, and a colorful service paint scheme. To the disadvantage of the Hawker airplanes were their wings which have outboard dihedral breaks. After a couple of weeks of stewing over the immensity of the project I decided to "go for broke." Win or lose, I was going to build my muffled airplane and would somehow manage to make it more realistic than previous semi-scale designs.

Building a heavier, more realistic airplane would be possible only if ways could be found to significantly increase the lift of its wing. As it happens, I have been using an airfoil test rig for about three years, and based upon experiments with different airfoils I was sure that extra lift was attainable. (Fig. 1)

Since my experiments may be of interest to other modelers and provide background for the development of the Sea Fury wing, I will chronologically explain the results of these experiments. Airfoil tests were necessary because there is little NACA airfoil data available at Reynolds numbers of less than three million ($R_n 3 \times 10^6$). Because our stunt ships operate at Reynolds numbers of less than a half million, air is relatively much more viscous making most NACA data concerning coefficients of lift, drag, and pitching moments practically useless. To obtain usable performance data I ran tests on

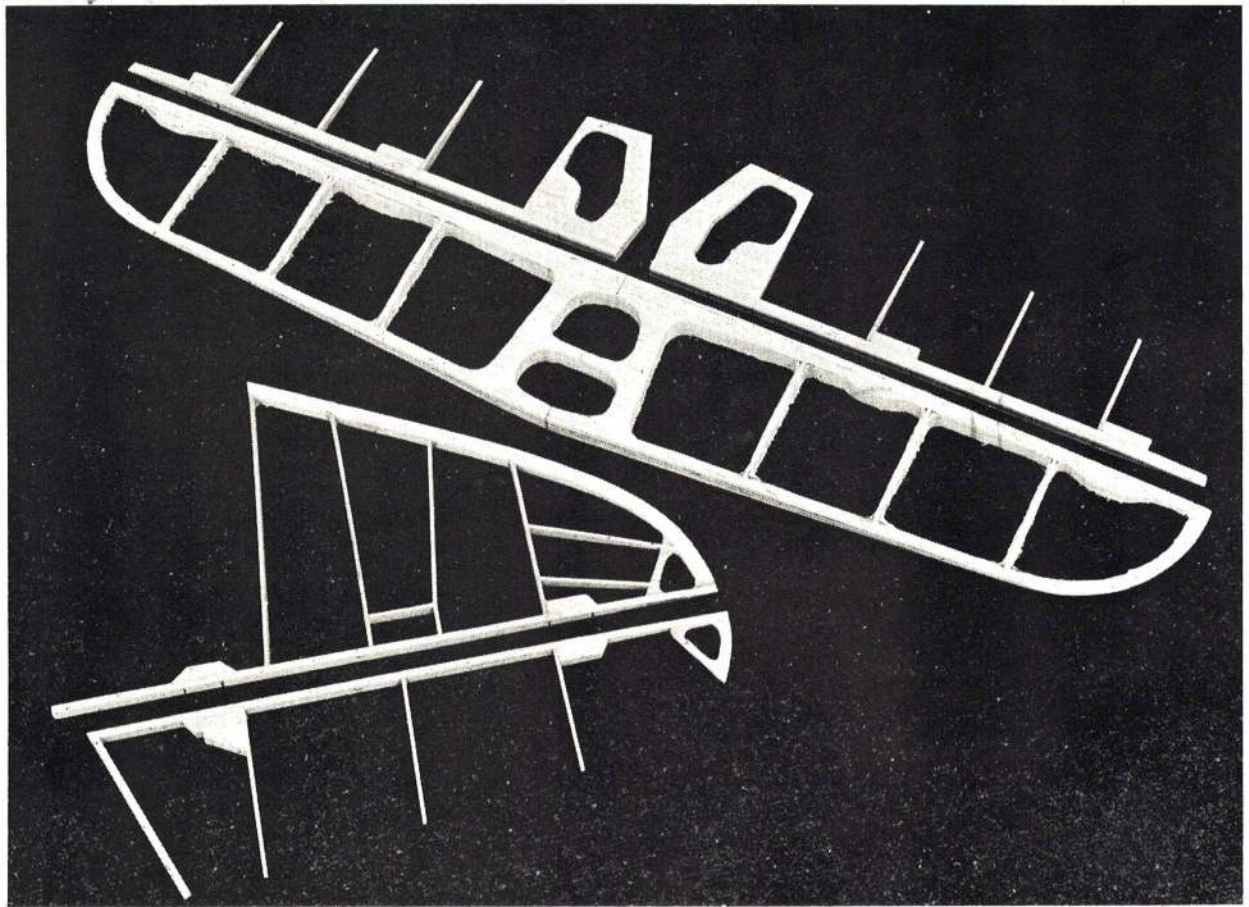

Cores for 1/16 sheeted tail surfaces. All these assemblies, as shown, weigh .4 oz.

The Sea Fury's shock absorbing gears and Rabe's method of lacing them to their mounts with .032 aircraft brass safety wire. Will never loosen at all.

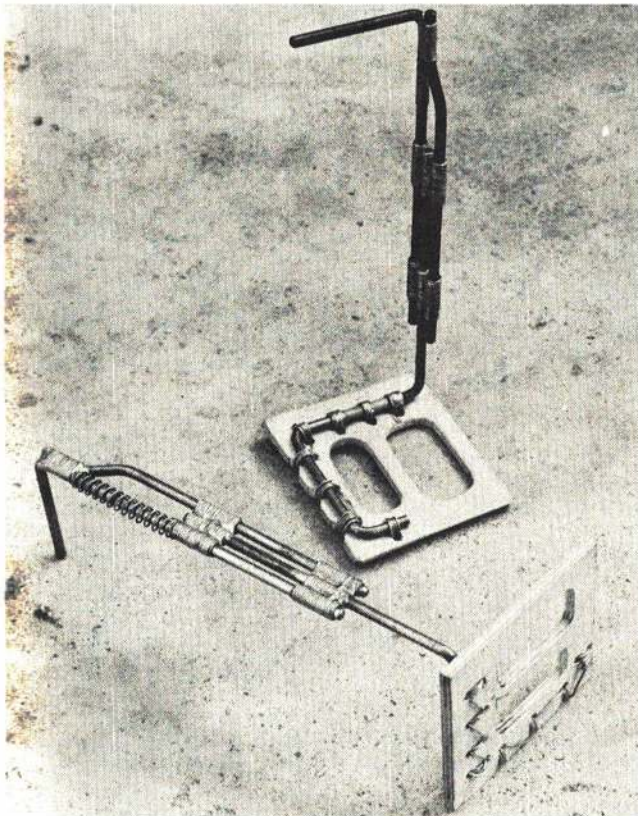

Method of assembling molded fuselages. Second half is still on mold. Most sanding done while on mold. Four aft bulkheads laminated 1/32" ply 3/32 balsa. Note tailwheel mount installed.

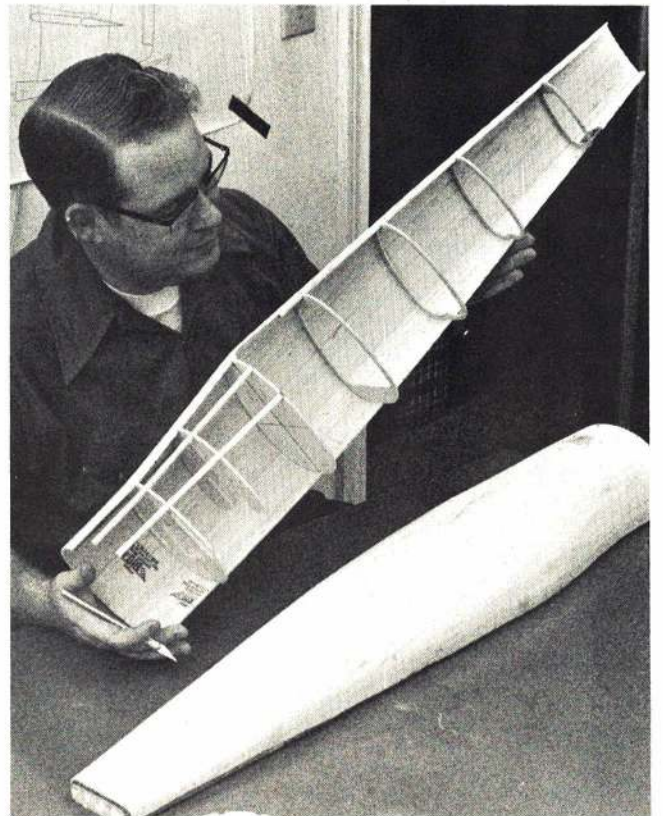

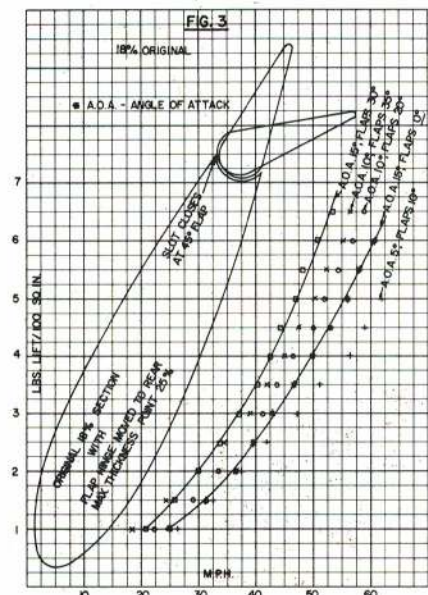
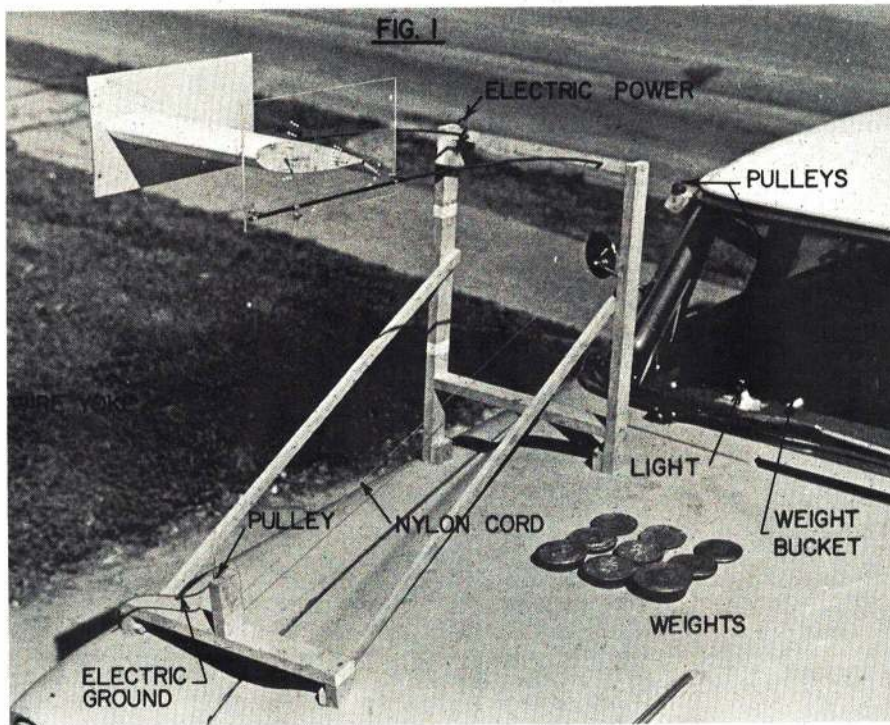
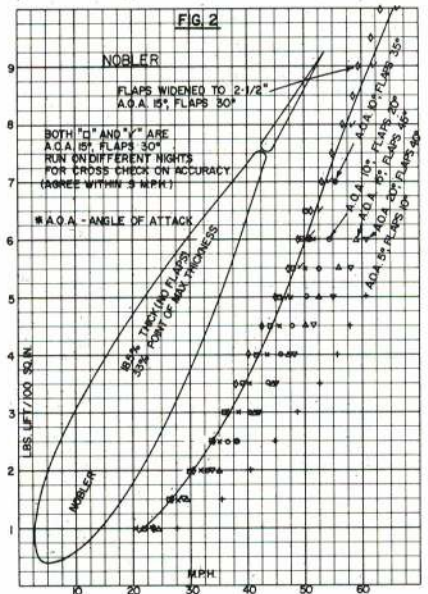
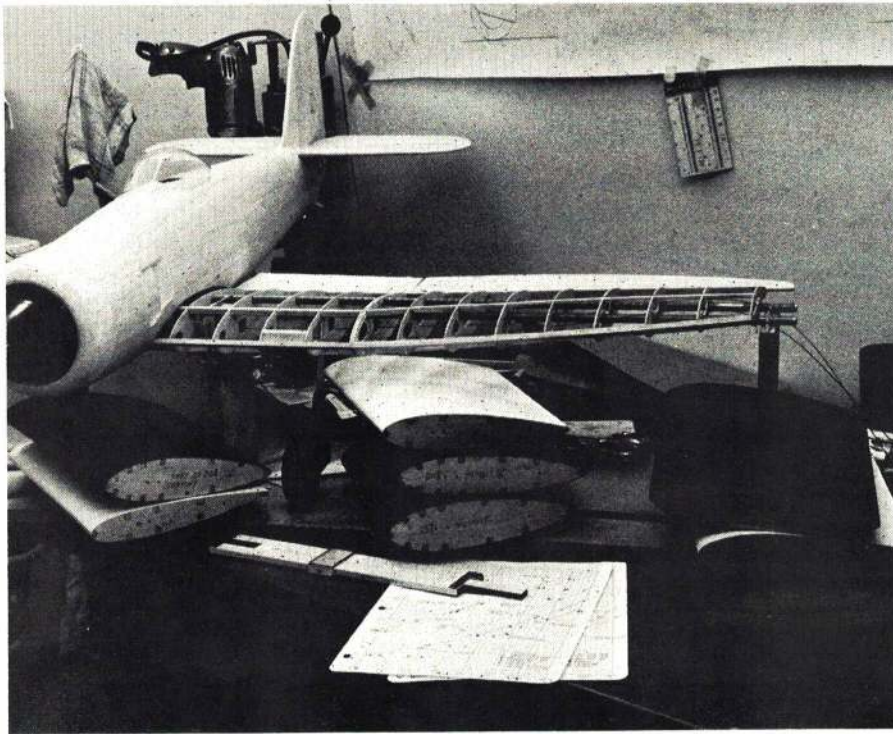

Top left: Airfoil test sections actually used to prepare graphs. Left: Airfoil test rig. All runs late at night on straight, smooth stretch of back country roads. Top right: To investigate UC Stunt airfoils, one must begin by understanding the best available "classic" airfoil—the Nobler. Above: A "simple" type flap. Harder to build, nearly impossible to properly hang and 10 to 15% less efficient than Nobler airfoil with sheet flap.

model size stunt sections at stunt speeds and used a Nobler test section for comparisons. From my first tests, I found that: Nobler sections produce more lift with 20° of flap than with 40° of flap, probably due to flap stall (optimum flap is near 30°); wider flaps provide more lift; sealing a rather wide hinge gap produces no significant improvement; turbulators installed at 10, 15 or 20% chord neither help or hurt lift measurably. These findings should apply to nearly any 20% symmetrical airfoil. (Fig. 2)

Next, I designed my first "super" airfoil. It was a built-in, "simple" flap type where the flap forms the aft

contour of the wing much the same as Keith Trostle used on his Nats-winning Focke-Wulf Ta 152. I tried to go Keith one better and use a full-scale aircraft practice of moving the flap hinge line slightly aft. When this flap moves down, the nose of the flap moves slightly upward, closing the hinge gap and projecting a slight "bump" at the hinge line. This "bump" in full-scale aircraft improves maximum lift by reattaching the separating boundary airflow as the airfoil nears stall. I was so convinced this wing would offer an improvement over the Nobler type that I designed my first super semi-scale stunt ship around it. It was to be a T-28B with an exact

scale fuselage from North American lofting data obtained from Dave Platt. Imagine my surprise and disappointment when tests showed that, in spite of the more sophisticated hinge location, my "super" airfoil performed about 10% poorer than the smaller, thinner Nobler airfoil plus its sheet flap. (Fig. 3)

To find the reason for my "super" airfoil's poor performance, I researched about 30 years of NACA Technical Reports and found that "simple" flap airfoils at $R_n 3 \times 10^6$ produce a C_L Max (maximum coefficient of lift) of about 1.6 (call it a figure of merit). "Fowler" flaps can produce a C_L Max of about 2.8 at $R_n 3 \times 10^6$. Although a "Fowler"

HARDENER for:
"5 MINUTE" EPOXY
CAUTION: KEEP FROM FIRE
CAUTION: DO NOT EAT
CAUTION: DO NOT DRINK
CAUTION: DO NOT INHALE
CAUTION: DO NOT GET ON CLOTHES

DEKON
"5 MINUTE" EPOXY
for Super Fast Repairs

SIZE OZ.
R-205 1 \$1.25
R-206 2 1/2 \$2.25

LONG WRENCHES
6 INCH REACH
LW98, pair . . 98¢

Allen-type for those hard-to-reach places. Fits all Du-Bro socket head cap screws. Fine for bench and field box

DU-BRO

FOR THE FINEST IN R/C FITTINGS USED THROUOUT THE WORLD

MADE IN U.S.A.

LA-75
Consists of 1 arm, 1 cap screw.
FOR 5/32" WIRE
75¢ EACH

1 1/4" STEERING ARM

R/C TANK FILTER

- Combination Weight and Filter
- Designed to Fit All Clunk Tanks
- Made of Sintered Bronze To Give the Ultimate in Filtering

98¢ ea.

Where performance counts, specify DU-BRO

SMALL SERVO
60 PIECES SS 120

MOUNTING HARDWARE
Enough For Five Servos \$120

SCREW (No. 2) Sheet Metal (20)
WASHER (FIBRE) (20)
SPACER (20)
DRILL 1/16" HOLE

FINEST CONTROL HORNS AVAILABLE
NYLON CONTROL HORNS

DU-BRO CH-49 EXCEPTIONALLY CLEAN LINED, SMOOTH HORNS. NO UNWANTED GROOVES IN THE BASE. REINFORCED NUT PLATE ASSURES GOOD TIGHT FIT TO CONTROL SURFACE WITHOUT DISTORTING HORN POSTURE. PRECISION FORMED OF HIGH GRADE NATURAL NYLON. FOUR THROW ADJUSTMENT POSITIONS SET CONTAINS ONE LEFT-ONE RIGHT HORN. TWO SELF-THREADING NUT PLATES AND FOUR 256's, SCREWS 8 PIECES

High 1 1/4" HORN 3/4" BASE 1/2"

CH-49 49¢

CATALOG NO. TF-1

DU-BRO NYLON HINGES
EASY INSTALLATION
Pkg. of 6 \$1.10 CAT. NO. H-6
Pkg. of 15 \$2.49 CAT. NO. H-15

Hinge Pin locked in place

SMALL SERVO Natural Rubber GROMMETS
20 Pieces 59¢

Embossed letters and lines make a better gluing surface.

\$0 59

WING BOLT SET—WB2
The up-to-date way to fasten wings to fuselage. "No Noise" Nylon bolts and Nylon threaded blocks.

Complete set of 22 PIECES ONLY \$1.25

Strip Aileron Horn Wire CONNECTORS—AH79
These natural nylon fittings simplify servo link hook-ups

NO NOISE

Each set contains 2 Dura-Collars, 2 slot head set screws, 2 horn connectors

AH79 79¢

AILERON HORN WIRES LB89
with Nylon Bearings. Ideal for strip ailerons, hi, mid or lo wing planes.

NOISELESS—RELIABLE FREE ACTION

Set of 2 horn wires and 2 mounted bearings LB89 89¢

GEAR STRAPS—GS25
LANDING GEAR FASTENERS
Light—Strong—STEEL

12 PIECES ONLY 25¢

FOUR NYLON REPLACEMENT BOLTS TO FIT WING BOLT SET

RB-75 75¢

Complete . . . fully adjustable . . . can be used on any high, mid or low wing plane.

NO NOISE!

strip aileron linkage hook-up

22 PIECE SET \$2.95
Cat. No. AL-295

steerable nose gear

SHOCK ABSORBING COMPLETE
Quality—durable . . . nylon nose gear blocks . . . heavy duty steering arm

5/32" WIRE

\$295 EACH
Cat. No. NG-1 Straight
Cat. No. NG-2 Bent

NOSE GEAR 5/32" WIRE N.W-75 75¢

NYLON Short steering arm

FOR 5/32" WIRE
Consists of 1 arm, 1 cap screw, 1 collar, 1 set screw.

75¢ EACH CAT. NO. SA-75

\$125
NYLON blocks

FOR 5/32" WIRE
Consists of 2 blocks. 4 bolts, 4 nuts, 4 lock washers, 1 nylon spacer.

CAT. NO. NB-125

IDEAL FOR R/C PLANES . . . BOATS . . . AND OTHER MECHANICALS

CUT SLEEVE AND CABLE LENGTHS TO FIT INSTALLATION.

DU-BRO "FLEX-CABLE" PROVIDES THE ULTIMATE IN CONTROL CABLE ASSEMBLY . . . HIGHLY FLEXIBLE . . . FREE RUNNING . . . NO STRETCH CONTROL SETTING FEATURES.

ONLY \$1.49

DU-BRO PRODUCTS, INC. WAUCONDA, ILL. 60084

Send Stamped, Self Addressed Envelope for Catalog
We couldn't possibly include everything in one ad

DU-BRO R/C ACCESSORIES
480 Bonner Road, Wauconda, Illinois 60084

Quality FUEL TUBING
2 FEET! 49¢

Specifically compounded to give fast high heat resistance. Non-crystalline. CAT. NO. FT-1

Quality FOAM TAPE
3 FEET! 60¢

CAT. NO. FT-60

Where performance counts, specify DU-BRO

SEA FURY I

by
AL RABE

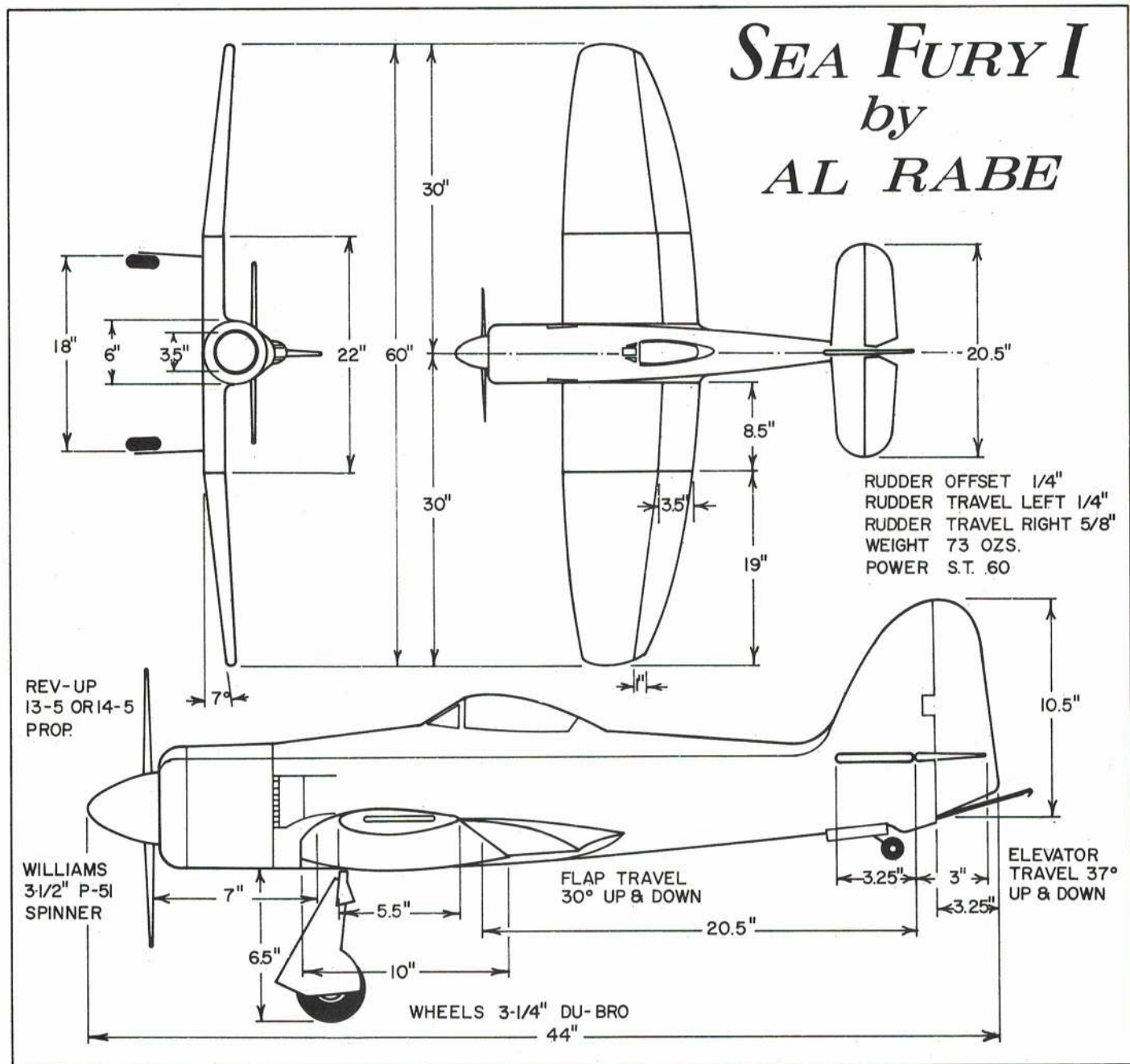

flap moves to the wing trailing edge while extending (which our stunt ships can't duplicate), the fully extended "Fowler" flap that produces this C_L Max of 2.8 looks much the same as our stunt airfoils with a depressed flap hinged to the wing trailing edge. So, while our sheet flaps aren't retractable, they do appear to have the lift capabilities of the "Fowler" flap. At this point, I removed my T-28B ribs from the jig, put away the plans, and packed the rifle-barrel-like molds I had machined to form molded balsa flap leading edges. The T-28B project was dead—that airplane just wouldn't look right with a larger wing.

In my NACA studies I also found flaps work better on thicker airfoils than thin airfoils, I suppose because the airflow is better directed across the hinge line and flaps. My own tests showed that a flapped stunt airfoil lifts

about half again more weight than a no-flap airfoil of the same total chord length. (Fig. 4)

At this point I built my very successful Bearcat III utilizing a molded balsa fuselage and making two very significant changes in the wing layout. First, because of the NACA studies, I profiled the aft portion of the Bearcat III rib to transition more smoothly into a deflected flap by adding curvature from the spar aft as opposed to the relatively flat shape of the Nobler rib. Second, from my own tests, without changing the overall shape or the area of the wing, I relocated the Bearcat's flap hinge line, angling it forward, so the flap would maintain a constant percentage of the wing chord instead of narrowing to insignificance as it approached the wing tip. This straight trade of wing area for flap area increases the lift of the wing tips by about 50% and accounts

for about a 20% overall improvement in the total lift capability of the wing. This effect was also verified by modifying the original Bearcat I to increase its flap area by cutting away the trailing edge of the wing at the tips and building new, larger flaps. This modification noticeably improved the Bearcat I's corners and was incorporated into the American Aircraft Modeler plans. (Fig. 5)

Next, I found an NACA graph of C_L Max of symmetrical airfoils of various thicknesses, with and without flaps. (Fig. 6) This chart shows what many stunt fliers have read for themselves in various publications—a 12 to 15% symmetrical section will give maximum lift. But that is true only *without flaps*. This graph also shows that flaps work better on thicker airfoils. Highest C_L max were obtained at approximately 28 to 32% thick sections with flaps. To test

(Continued on page 70)

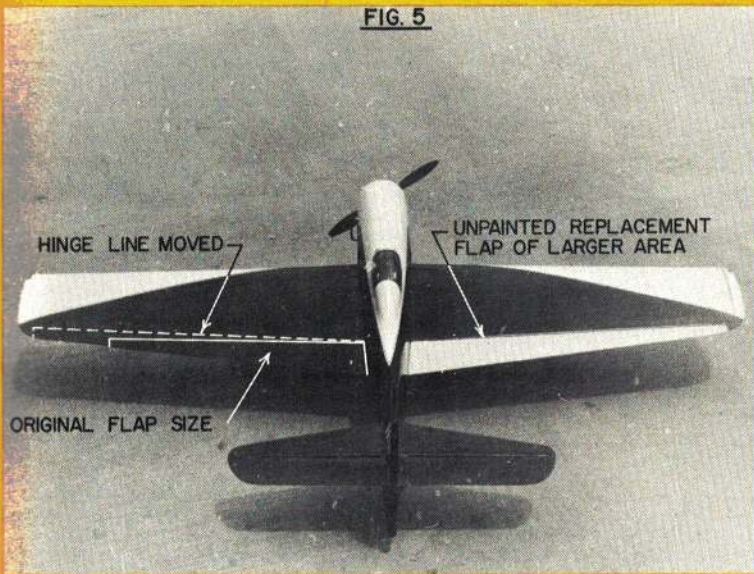

Bearcat I modifications. It's never too late to cut into a good stunt ship to improve its performance. Bearcat I had 950 logged flights when this modification was made.

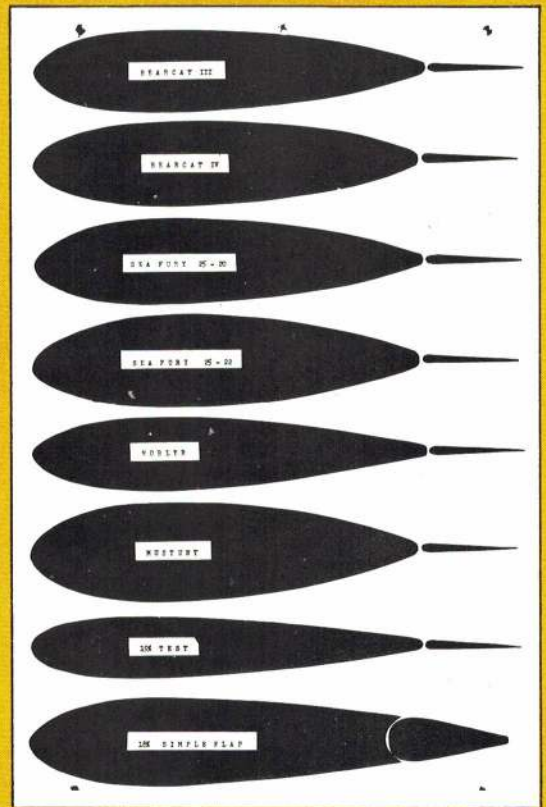

Airfoils presented here are 25% of original size.

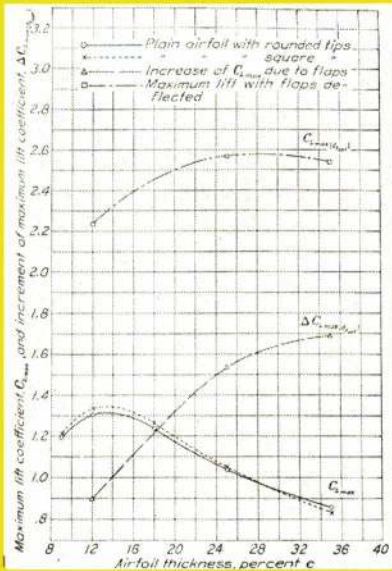
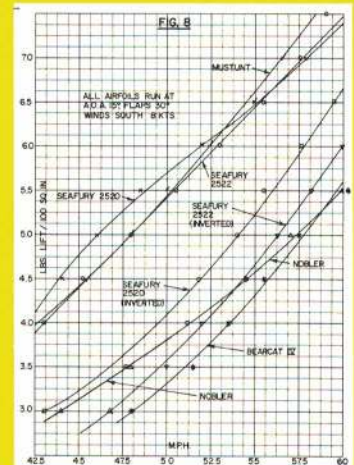
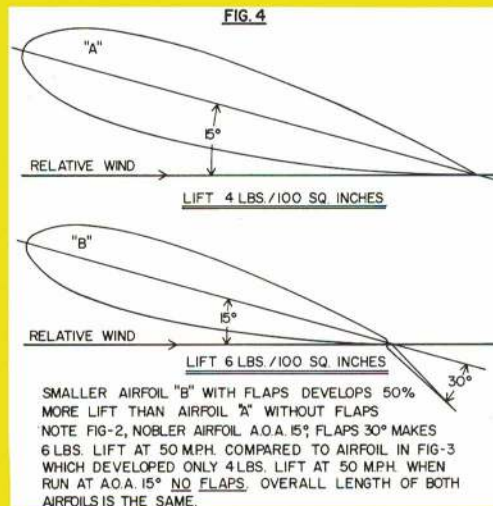
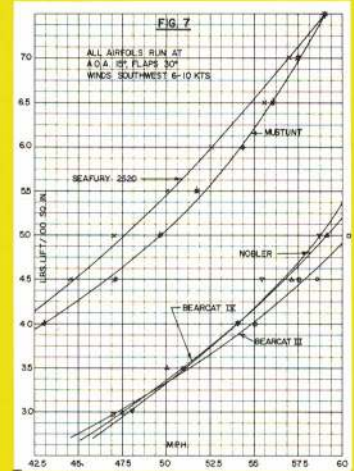

Figure 6: Variation of maximum lift coefficient for an airfoil, with and without flaps, and increment of maximum lift coefficient due to flaps with airfoil thickness for three NACA airfoils. Reynolds number, 3,000,000; aspect ratio, 6.

Figures 7 and 8 show improved lift attainable by increasing thickness of airfoil.



CARL MARONEY ON RC

SAC Instrumented: With RC Soaring Interest skyrocketing throughout the United States in the past two years, the Academy of Model Aeronautics during the Nats Executive Council Meeting in 1972 established a Soaring Advisory Council (SAC) effective 1 January 1973. The Soaring Advisory Council is a National organization since each AMA District will have an RC Soaring Advisor who will serve on Soaring matters to the District Member on the RC Contest Board. This advisor will be appointed by the District V.P. In addition, the eleven RC Soaring Advisors will, as an Advisory group, review Soaring matters for the RC Contest Board and submit RC Soaring proposals to the RC Contest Board. This Advisory group will be headed by one of the eleven members, or by an additional member, selected by the AMA President.

This new addition is an expansion of the present AMA structure, thus allowing each District to be represented on the Contest Board as matters pertaining to RC Soaring without generating a completely new organization and likewise new organizational problems, e.g., meetings and communication media, etc. The advantages of this change not only yields equal geographic representation but also utilizes existing mechanisms (Competition Newsletters and Model Aviation, the official magazine of AMA News and is part of AAM) for national communication to all modelers.

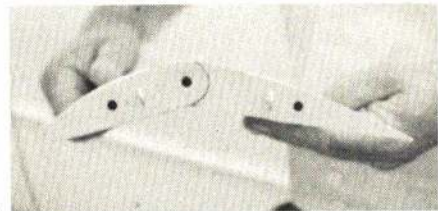
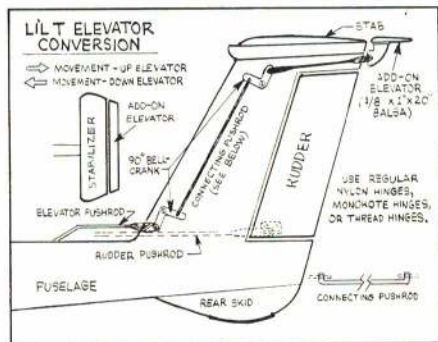

George Durney of Dover, Delaware is experimenting with variable airfoil in flight to determine the effects of varying aerodynamic flow during changing weather conditions.

Li'l T Conversion: Sixteen-year-old Don Edberg (Covina, California), who flies full-size sailplanes, couldn't resist the challenge of RC gliders after buying a six-channel Micro radio system for \$50. The Li'l T glider was selected as his first project for the newly acquired equipment. After logging 3½ hours of flying time, Don wanted a ship with greater response, this leading to the Li'l T conversion from rudder-only to rudder and elevator controls. What is unique about this idea is that the conversion can be done after the model has been finished and/or flown. The designer feels, however, that there is one precaution to observe during installation, which is to ensure that all bellcranks and pushrods move freely. Details for this conversion are illustrated in Li'l T Conversion Figure.

Trade Show Time: Those finishing touches should be in process on that winter glider project for entry in the static sailplane competition at the Annual Toledo Trade Show. This show is not only for the exhibitionist but also the inquisitive. This gathering will provide a social meeting of glider enthusiasts to discuss building and flying problems, and to also relate personal experience with others. Those of you who attend this function please make it a point to let me meet you. I will most likely be located at the ECSS booth.



W. Zehr and his original design—Zehrgutt—in which he reversed a Du-Bro canopy to fit a glider.

BOB MEUSER ON FF SPORT

Postal Contest: The Brooklyn Sky Scrapers announce a postal contest for hand-launch gliders to be flown on any day during April. There are two events: (1) Three-man teams, German rules, that is, one minute max, best six out of ten flights, next highest flight times used to break ties. (2) Individual longest flight, binoculars permitted. Entries must be postmarked no later than May 5. A short description of the gliders, or a small three-view showing the main dimensions, and a brief report on the flying site and weather must be included with the entry. Appropriate tokens of recognition will be given to winners and entrants. Send your entry to John Kaufmann, 189-04 64th Ave., Fresh Meadows, N.Y. 11365. It is not mandatory, but it would help if you notified him of your interest to enter before April 1.

Oh Two Oh Tee: The 02-powered Old-Timers were plugged in this column back in August 1970, and a photo of Bob Oslan's So Long, later featured in the June 1972 AAM, was shown. Bob has recently started production of kits for the So Long, along with a 32-in. version of Sal Taibi's popular Brooklyn Dodger, and several more are in the planning



Bob Oslan's 020-powered Brooklyn Dodger weighs in at 4½ oz., flew right off the drawing board. Very docile—seeks out thermals as though it had radar. Now kitted.

stage. They sell for \$7.95 and can be obtained from Cal Aero Model, 7142 Bluesails Dr., Huntington Beach, Calif. 92647 if your hobby shop doesn't carry them. Thirty-six-inch versions of many of the Old-Timers are available as kits from Micro Models, Box 1273, Covina, CA 91722. If you prefer to build from plans get the So Long plans from AAM Sudden Service Plans. The original plans of many of the Old-Timers, photo-reduced to 02-engine size, may be obtained from Free-Flight Specialties, 6255 S.W. 47th Pl., Portland, Oregon 97221. We hear that the mini-Old-Timers are excellent subjects for (you should pardon the expression) RC, using lightweight Ace single-channel systems.

The Minis Are Coming: And the Maxis too. If you are 12 or under you qualify for the Minis, 15 or under for the Maxis. These are postal contests sponsored by the National Free-

Flight Society; you make your flights at your convenience during a specified two-month period and mail in your best times. There are four events for the Minis: Hand-Launch Glider—any design; Rubber-Power Simple Stick—any small model with an exposed rubber motor; Catapult Glider—any design, but launcher is restricted to a 16-in. piece of 1/8-in. rubber made into a loop eight in. long, one end of which is tied to a short stick—contestant holds the stick in one hand and the model in the other when launching; R.O.G. Profile Flying Scale—rubber powered, model must take off from the ground, and it is strictly for duration, no points for scale fidelity. For the Maxis there are three events: H.L. Glider; Unlimited Rubber—any rubber-power model up to a 36-in. wingspan; Towline Glider—50-in. maximum span, 100-ft. towline. Take all the flights you want, but all the flights for an event must be made on the same day. Send in the times for the best three flights. The "max" is three min. for the Minis, two min. for the Maxis; any flight time in excess of that doesn't count. Results for the Minis are to be sent to Richard Whitten, P.O. Box 176 Wall Street Station, New York, N.Y. 10005, and for the Maxis to Lin Haslam, 3731 South 5450 W., Salt Lake City, Utah 84120. The schedule: February-March, Groundhog Mini; April-May, Spring Fever Maxi; September-October, Halloween Mini; November-December, Holiday Season Maxi. Certificates are sent to participants, and names of record breakers are listed in the Mini-Maxi Hall of Fame. For more information write to Richard Whitten, or better still, subscribe to his fine publication for Juniors, *Star Skippers*; \$1.50 for eight issues.

Wondering what to build? For H.L. Glider try the Driftwoud (AAM, September 1972, page 44.) For the Rubber events try some of the models kitted by Oldtimer Models, 7454 W. Thurston Circle, Milwaukee, Wisc. 53218, or Marlow Engineering, 6850 Vineland Ave., North Hollywood, Calif. 91605. A simple model with a fine record is the . . .

Tyromin: This neat 12-incher, designed by Ernst Johnson, is only a bit more difficult to build than a Delta Dart, and is small enough to fit in an oversize shoebox. As it makes maximum utilization of stock wood sizes, it is excellent for group building activities. The 5½-in. plastic prop can be obtained at hobby shops, from Sig, or from a dime-store ready-to-fly. The special thrust bearing can be obtained from Richard Whitten (address above) for 35 cents; he can also supply kits, plans, and parts for other Junior modeling projects. At that price the special thrust bearing is the best bargain in town, but a plastic one would probably do in a pinch. For full-size plans of the Tyromin, along with building and flying instructions, send a stamped self-addressed large envelope to Bob Meuser, c/o AAM.

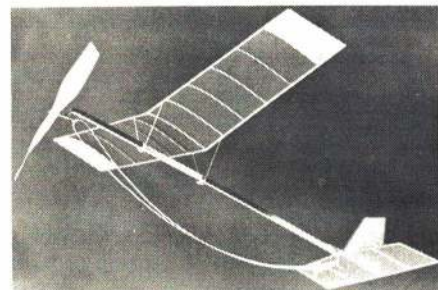
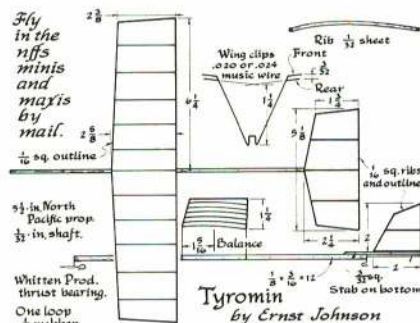

Twelve-in. Tyromin, designed by Ernst Johnson.

1973 U.S. F.A.I. FREE-FLIGHT TEAM

F.A.I. POWER

Henry Spence
Frank Wolff
Tom McLaughlan

NORDIC

Hugh Langevin
Paul Crowley
Vince Croghan

WAKEFIELD

Frank Parmenter
Bob White
Jon Davis



FREE FLIGHT FINALS

THE U.S.A. F.A.I. FREE FLIGHT TEAM SELECTION FINALS.

DICK MATHIS



The exhausting process of selecting the U.S. Free Flight team for the 1973 FAI World Championship to be held in Austria was completed at Caddo Mills, Texas over the Fourth of July holiday under conditions that challenged even the bravest. The ninety-odd contestants were the survivors of two rounds of local and regional elimination contests held last summer with over a thousand fliers participating. Three-man teams were to be selected for Power, Wakefield, and Nordic A-2 Classes. The honor of representing the U.S.A. in the World Championships is generally regarded as one of the ultimate achievements in domestic aeromodelling, so the fliers approach the contest in the same way a sprinter prepares for the Olympic team selections.

Many arrived a week in advance to adjust to the conditions of Texas, which can be quite different than those in California or New York. The early arrivals were greeted by strong wind, and unfortunately, most chose to wait for calmer conditions in which to practice, a decision that later proved to be costly. The rare calm conditions during practice brought flurries of activity with many very impressive airplanes in evidence, but one could not help wondering what would happen if the wind returned during the contest. As it turned out, the actual contest was very windy and most contestants found themselves badly handicapped in terms of model design and technique. Whether the wind changed the results is a moot point, but it is ironic that the team selected in gale winds will fly in a near calm condition next year in Europe.

The contest required fifteen flights (five each day) in 90-min. rounds beginning at 6:30 A.M. The early start was intended to minimize the effect of thermals and put the premium on model performance. All FAI FF events are flown with a 180-sec. maximum, meaning a 180-sec. flight is a perfect score and anything over is not counted. Binoculars (allowed in FAI) were necessary for the timers since the models were being blown out of sight of the naked eye before 120 sec.

The Power event is easily the most spectacular of the FAI classes, with 25,000 rpm Rossi 15s screaming, rocket-like climbs, and a touch of unpredictability brought about by trying to control the speed with clockwork timer actuated automatic elevator and rudder trim changes during flight. The typical Power model sports a low thrustline pylon layout with aft rudder, Rossi 15 (the maximum size limit) motor, Seelig four-function clockwork timer for engine shutoff (ten sec. maximum motor run) rudder and stab trim change, and dethermalizing after 180 sec. The models are heavy for free flight (26.5 oz. minimum) and small for their power (about 450 sq. in. wing area). All the top placing models followed this layout, but there were still some interesting variations, such as Doug Joyce's pusher canard, high aspect ratio, high thrustline types, and two parasol designs. But it was not design that made the difference

(Continued on page 82)



Californian Earl Thompson missed a max on last flight, ruining perfect score and dropping him off sure spot on Power team.

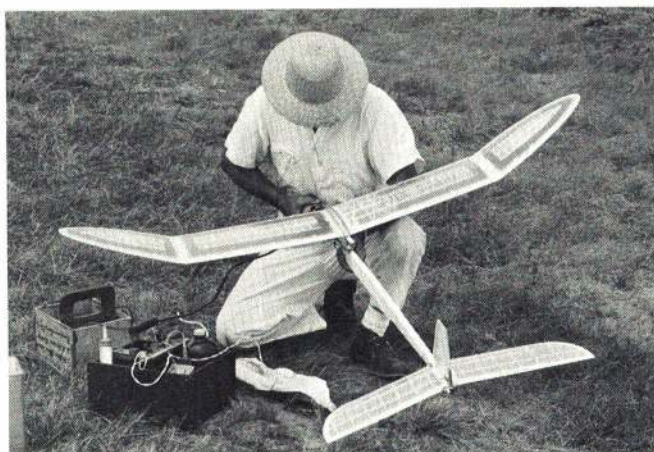

Tommy McLaughlin of Pensacola made the team after years of innovation and hard work—brought the world's largest chase crew with him.



George Zenakis almost made team despite two disastrous zero score rounds. One of many father-son teams.



Bob Hatschek's elegant nordic towliner strains in wind (note wrinkled tissue on top of wing).



Bob "The Godfather" White will have a chance to improve on his third place at the 1971 World Championship as a Wakefield team member in 1973. Fudo Takagi lights fuse.



Nineteen-year-old Jon Davis of Albuquerque kept cool, waited for good air, made Wakefield team. Aluminum tube fuselage.

Beautiful power model (designed by Jim Taylor) had aluminum front fuselage, sheet wing. Flown by Bob Bicknell of Albuquerque.

Facing page: Frank Parmenter (Texas) repeated on Wakefield team for the umpteenth time. Note electronic thermal detector.



R/C Flying Fun!

THE SIMPLE SYSTEM--

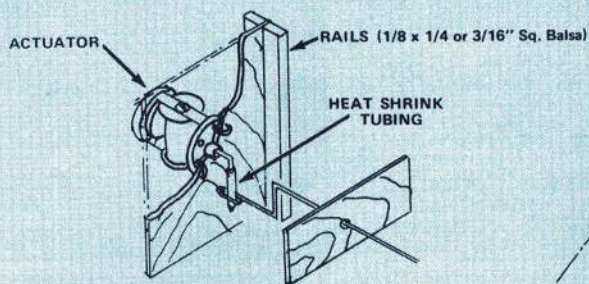

pulse commander

--WITH Nicads and Charger
--From 2.5 Ounces

RUDDER-ONLY PULSE IS:

- * LIGHTEST WEIGHT--2.5 oz. for Baby.
- * LOWEST COST--WITH airborne nicad batteries and charger--begin at \$69.95!
- * SIMPLEST--only one moving part, easily serviced and maintained; noise free.
- * VERSATILE--Arrange to suit your particular installation. You can go up or down in size without obsoleting receiver or transmitter. Simple changes of battery pack and actuator allow change. Or add Motor Control to Standard or Stomper--using same battery pack.
- * FULLY PROPORTIONAL
- * GREAT for Beginners--FUN for Experts.

PULSE COMMANDER R-O SYSTEMS

Completely wired, tested and guaranteed with airborne battery pack and charger, but less transmitter battery.

10G15--Baby System	\$69.95
10G15T--Baby Twin System	\$72.95
10G16--Standard System	\$71.95
10G17--Stomper System	\$74.95

26.995, 27.045, 27.095, 27.145, 27.195
Please Specify Frequency

Flite Pak Weights & Recommendations

Unit	Weight	Recommended
Baby	2.5 oz.	Pee Wee .020 Up to 48" gliders
Baby Twin	2.7 oz.	Tee Dee .010-.020 Up to 72" gliders
Standard	4.4 oz.	.049 to .10
Stomper	4.8 oz.	Tee Dee .049-.23

R/O PULSE HANDBOOK
WITH
UPDATED CATALOG
Only \$1.00
Refundable First Order

Handbook has expanded data on How Pulse Works, Installation, How to Fly -- and much more. Most complete information on Pulse Rudder-Only available anywhere.

New catalog is completely updated. Includes many items from major manufacturers.

Price is \$1.00 via THIRD CLASS BULK MAIL. If you wish faster delivery, add 50¢ for turn around FIRST CLASS service.

ACE RADIO CONTROL, INC. * BOX 301 * HIGGINSVILLE, MD. 64037

NAME _____
ADDRESS _____
CITY _____ STATE _____ ZIP _____

QUANTITY	STOCK #	NAME OF ITEM	PRICE	TOTAL

Master Charge or BankAmericard No.

Add \$1.00 shipping-handling for direct mailorders except catalog

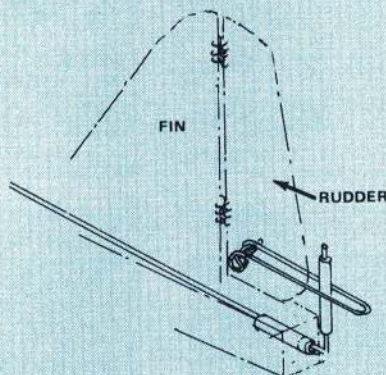

New small PRACTICAL flying machines. These designs really fly--and fly well; not in the novelty class. Easy to build, low in cost, inexpensive to fly. For use in limited areas.



DICK'S DREAM KIT Highly Recommended for Beginners

† 34" Foam Wing sections. † Top grade die-cut wood parts. † For .020 engines. † Commander Baby or Baby Twin. *Owen Kampen design.

13L100--Dick's Dream Kit \$6.95



ACE HIGH GLIDER KIT

† 70" Foam Wing sections. † Precision machine cut and sanded wood. † For .049--Power Pod parts supplied. † Recommended for Rudder-Only--Standard or Stomper. *Owen Kampen design.

13L104--Ace High Glider Kit \$14.95

Watch for New Rudder-Only Plane Kits

TRY YOUR DEALER FIRST--if he does not have it, order direct using coupon for fast and courteous service.

pulse commander FLITE PAKS

Our Commander Rudder-Only Flite Pak are available separately for the convenience of our customers who wish to use a complete installation. They include nickel cad battery, On-Off switch, receiver and actuator--assembled and tested. More expensive than the Actuator Battery Combos, it does not require any shifting. This offers a convenient and complete way of making an installation in another airplane without removing your receiver.

Be sure to specify frequency to match your transmitter.

The Baby and Baby Twin units contain the 225 ma 2.4 nickel cad batteries; the Standard and Standard Twin (Stomper) contain 500 ma 2.4 v nickel cad batteries. Charger is not supplied.

72G15--	Baby R/O Flite Pak	\$39.95
72G15T--	Baby Twin R/O Flite Pak	\$42.95
72G16--	Standard R/O Flite Pak	\$41.95
72G17--	Standard Twin Flite Pak	\$44.95

(Stomper)

26.995, 27.045, 27.095, 27.145, 27.195 MHz
(Please specify frequency desired)

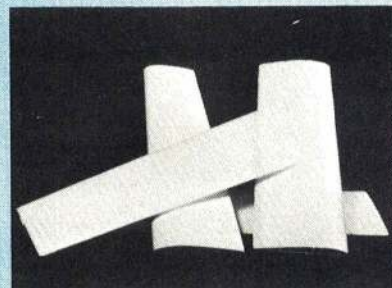

ACE MINI FOAM WINGS

Ace Foam wings have a semi-symmetrical airfoil developed by Owen Kampen. Available in two configurations: Constant or tapered chord.

The constant chord measures 35" span, and is 5 1/2" wide, 192.5 square inches. Weight is 3 ounces. The taper chord is 35" span, center is 5 1/2", which tapers to 4", 166.25 square inches. Weight is 2+ ounces.

Wings come in two pieces of 17 1/2" so that they may be easily sanded and epoxied for correct dihedral. May be used as they come, or may be finished with a polyurethane varnish or striped with Monokote for trim, painted with Polyurethane Varnish, or covered with TopCote and doped.

RCM has plans for planes using them; other magazines have had or will have. Also lend themselves excellently for the home-brew builder who wants a proven and tried airfoil section for planes he wants to design himself. Combinations for longer and wider wings possible.

Build with mini foam wings; a real break-through for fun!

13L166--Ace Mini Foam Taper Wing \$2.95
13L192--Ace Mini Foam Constant Wing \$2.95

TOPCOTE COVERING

Top-Cote by Quick-N-Easy Products is a polyester film covering material that is applied with heat--or in case of foam wings will adhere with slight tackiness it has. Can be doped or painted. Weighs less than 1/4 oz. per square foot and will accept dope, lacquer or epoxy paints. Will not wrinkle on planked or foam surfaces and does not require high heat to shrink.

No. 24L160--TopCotE Clear 26 x 60" roll \$3.95
No. 24L161--TopCotE Chrome 26 x 60" 5.95
No. 24L162--TopCotE Clear 26 x 120" 6.95
No. 24L163--TopCotE Chrome 26 x 120" 10.95

Ideal for Ace Mini Foam Wings

Canadian Commander Manufacturer

All Canadian customers for the Commander R/O Pak should contact H & W Enterprises at Box 972, Regina, Sask., Canada

**ACE R/C digital commander
KIT**

Two channel system using IC's and latest state of the art; may be expanded to 4-6-8 channels.

Receiver-Decoder (2) will work with most modern 4-6-8 channel digital transmitters on same frequency! Reads aileron and elevator signals—ignores the rest.

Receiver-Decoder (2) works modern digital servos.

Receiver-Decoder (2) offer inexpensive way to go with your present system for glider, plane, boat or car: use with extra servos you already have. Or use our combo flite pak: receiver-decoder, two servos, etc.

Available on the following frequencies:
27.995, 27.045, 27.095, 27.145, 27.195
53.100, 53.200, 53.300, 53.400, 53.500

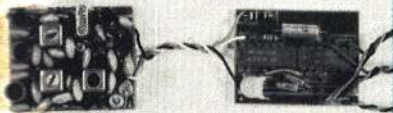

**digital commander
RECEIVER DECODER (2) KIT**

IC's simplify wiring and set up of 2 channel decoder. Receiver is exceptional double tuned front end using discrete components. Complete with detailed step by step instructions.

No. 12G20—Digital Commander Receiver-Decoder Kit (2) \$27.95
(Less case, connectors, switch)

Please Specify Frequency

- No. 19L50—Deans gold plated 4 pin connector set .95
- (NOTE: See D & R connectors elsewhere)
- No. 40L252—CW DPDT Slide Switch .59
- No. 30L21—Switch Guard for above .39
- No. 21K30—Formed plastic Case for Receiver-Decoder. (All models) 2.00



**digital commander
SERVO KIT**

Housed in the D & R Bantam DS3P mechanism, uses WE 3141 IC for ease in assembly. Kit contains motor, pot, wiper and all components required, with step-by-step manual.

- No. 14G20—Digital Commander Servo Kit \$19.95
- No. 14G20L—As above, except with D & R DS2P Linear Mechanics (Less connectors) \$20.95

**digital commander
FLITE PAK KIT COMBO (2)**

If you intend to use Commander Digital (2) with your multi digital transmitter, all you need are the receiver-decoder and 2 servo kits. Combo offers savings over kits purchased individually. Includes 3 connectors, switch, hookup wire for cabling. Everything you need to make complete 2 channel-2 servo pack for your sailplane, boat or car, except batteries.

- No. 12G30—(2) Flite Pak Combo \$59.95
- No. 12G30L—As above, but with D & R DS2P Linear Mechanics \$61.95

Please Specify Frequency

PIGGY BACK 4 CHANNEL KIT

If you've been successfully using your Ace Digital Commander 2 channel receiver-decoder combination, you can inexpensively convert this to 4 channel operation for use with your 4 channel digital transmitter.

The conversion consists simply of adding another IC, and "piggy backing" it on top of the present IC 2 channel unit.

By slight readjustment of the packing, this will fit into the present Ace case (metal or plastic). When you consider that our 2 channel receiver-decoder kit is \$27.95, and the additional components and instructions required for converting it to 4 channel are only \$3.25, you can see that you have quite an effective saving.

Our piggy back contains the additional IC, complete instructions, and extra hook-up wire. No connectors are furnished. You have the option of going to additional Deans 4 pin units, or going to the D & R Block type.

We recommend the Ace Digital Commander Servo because of high resolution, fast response, low current drain, and light weight. Kits are available as listed elsewhere.

- No. 12K22—Digital Commander Piggy Back 4 Channel Conversion Kit \$3.25

**digital commander
4-6-8 CONVERSION KIT**

You have been asking for this—a kit to let you convert your Digital Commander receiver and 2 channel decoder or 2 channel Flite Pak to more channels. Here it is!

The 4-6-8 Decoder requires a new PC board, new IC and some additional components. Simple to wire. An 8 bit chip is used (Cost is a bit more than a 4) but you are not limited to just a 4 channel expansion. You can go up to 8, if your transmitter will!

Use your Digital Commander Flite Pak for 1, 2, 3, 4, 5, 6, 7 or 8 channels—depending on your transmitter. Unused signals are simply ignored.

Kit consists of basic components. New IC, PC board, all other required electronic components with complete instructions. No connectors supplied.

- No. 12G8—4-6-8 Channel Conversion Kit \$12.95

DIGITAL SERVICE CENTERS

In addition to our service center located at the factory at Higginsville, Mo., two independent service centers have been established. One is on the East Coast, and is designed for customers living in the eastern half of the United States; the other on the West Coast is designed for customers in the western portion. Central states still will be serviced from the factory. This will expedite service, and return to you, and should eliminate as much down time as possible. We recommend either of these service centers very highly.

They are as follows:

Ace Service Center EAST
Electronic Model Systems
103 Bannister Drive
Hampton, Virginia 23366

Ace Service Center WEST
Hillcrest Hobby Craft
3921 Fifth Avenue
San Diego, California 92103

TRY YOUR DEALER FIRST—if he does not have it, order direct using coupon for fast and courteous service.



Dear Friend:

To open this month's news we want to quote from George Eckschmied of Vancouver, British Columbia.

"Our weather has turned cold, and gets dark very early, so there is not much time left for actual flying.

"I must tell you about the experience of one of my friends and proteges who is flying your Ace High with the Pulse Commander and Standard Adams Actuator. He is just about nuts over his flying.

"He installed a single light bulb on the Ace High and goes flying in the dark! Uses a spot-light flash for landing!

"The other morning he came into my office, smiling ear to ear, and announced 'George, I have my night and fog flying qualifications.' Ground fog had been about 6 feet off the deck the night before, and the only way he knew where his plane was by listening to the sound of actuator banging from side to side. After his third flight of the day (night?) the wing had a thin formation of ice, so he called it quits. That's what I call dedication!"

Not only is that dedication, but that's also fine proof of the performance and reliability of the Commander systems. We're proud to get many letters like this attesting to the day after day satisfaction the Pulse Commander provides.

Incidentally, on the Standard and Stomper, you can decrease the total airborne weight by approximately 1 1/4 ounces by using a 225 mil stack pak batteries instead of the 500 mil units supplied. This will give you approximately one hour of flying time.

The Ace Digital Commander is also gaining new friends every day. Most gratifying are the many letters from satisfied users. Expansion for additional channels on the Flite Pak is now quite easy with the Piggyback for 4 channels or the Conversion kit for 4-6-8 channels. This will match most any present day digital transmitter.



The above photo is the third in a series of Roman Bukolt's Warbirds. This is the Hurricane Mark II. Our kit will allow you to make the above or ME 109, or P-51 B.

This "stand-off" scale job may be used with pulse rudder or digital 2 channel.

There are other exciting things in the works, both in the pulse field and in the digital field. Keep watching our ads.

Keep 'em flying.



Yours sincerely,

Paul

Paul F. Runge

BOB STALICK ON FF, GLIDERS, POWER, RUBBER, INDOOR

Old-Timers in Miniature with Glow: As one of those modelers who grew up after the "Golden Age" of modeling, I've always been fascinated by the ignition-powered, Rise-Off-Ground Old Timer. Now, thanks to the SCIFS (Southern California Ignition Flyers), there is a growing popularity in .020 glow-powered miniatures of those big beasts of yesterday. In fact, they are now on the scene of scaled-down So Longs, Mercurys, Miss Americas, Clippers, Brooklyn Dodgers, et al. The well-crafted kits include select wood and plans, in fact Ralph Prey in the "Satellite" reviewed Cal-Aero's So Long kit as follows: "What's significant is the quality these manufacturers have put into their kits and the end result is most important...they fly like all get out. Try one, you'll like it."



Mk. I Comet Clipper at the '71 Nats. Kits of this classic are now available to the old-time buff.

I have one of their So Long kits in front of me now as I write this, and if first impressions mean anything to you, it's great. The plans are full-size, even the wing, and you don't have to use "cooking oil" on the plans to build the other half of the wing, as is so often the case in plans. So many times plans are nondescript when it comes to building the fuselage—as though the builder knew all there is to know about building.

Not so with the So Long plans. They show seven steps on how to lay out the crutch, then the bulkheads, and even down to the direction of grain on the fuselage sheet covering. The dihedral dimensions also show you how much to raise each wing panel in inches with the main wing panel flat on the board.



Bill McDow with his 020-powered Cal-Aero So Long.

The wood supplied in the kit is all usable. Someone put a lot of thought in the selection of wood for each specific application. The rib wood is light and the trailing edges are straight, while the die-cut notches are also clean with no frayed edges. The strip wood is all straight and of exact dimension to fit. What will also grab you is the material supplied for covering. It's Jap tissue, both red and yellow—something you can actually use and not donate to the wife to use as stuffing for wrapping presents.

Included in each kit is an excellent description of how to adjust and fly the little baby you just spent hours reproducing. The flying instructions were written by someone that has flown old-time models, as they are very clear about those anxious powered flights. There's no question about its flying. All in all it's an excellent kit and well worth the price.

If you can't find these kits locally, check the ads in this issue of AAM, or write directly to Cal-Aero Models, 7142 Bluesalls Dr., Huntington Beach, Calif. 92647.

If Big Ones Turn You On: The real thing,

large, original size Old-Timers. Those kits are being reproduced, in short form, in a quality equal to the miniatures. Currently, the designs available from P & W Model Service, P.O. Box 925, Monrovia, Calif. 91016 include the Comet Clipper, Mk. I and II, Megow Ranger, Skyrocket B and others. However, if you want to power them with ignition engines—as you should if you really want to get into the Old-Timer thing—getting a good engine could be a problem. If you have a good engine, then you're on your way provided you avoid these experiences described by Mark Fechner in "The Dope Can." First mix up white gas and 70 weight oil 3 to 1, then put this pleasing mixture into the gas tank. Prime and choke freely, turn on spark and flip - flip - flip - pop - pop - flip, more choke, more prime, retard spark - flip - flip - flip - pop - bang. More prime, more choke, refill tank, advance spark and flip - flip - flip - flip - pop - bang - poop. Time for new batteries. More prime, more choke and flip - flop - flip - flop - flip - bang. Ouch!! You dirty, rotten ----! More choke, more prime. Retard spark. Flip - flip - flop - flop - poop - pooped out.

It is obvious that the crankee and the cranker are not getting along. Through a lengthy discussion with my technical adviser we came up with a sure fire—or no fire in this case—solution. This is done by removing the gas tank, back plate, and piston and rod. Attach 1/16" piano wire hook to the crankshaft. On this attach 20 strands of 1/8" brown rubber. Make sure to clear all bulkheads and place a wooden dowel in the rear of the airplane in a suitable position. This modification could never be complete without the removal of the 10 x 3 1/2 prop and replacing it with a 14 x 24 super folder. For the authentic sound, a Megow Hummer device must be installed. This is operated by a modified timer arm to suit! Remember to leave the spark plug and lead for visual effect.

Operation: Wind counterclockwise 700 turns. Now, hold tip of prop in left hand, model in right hand (opposite if left-handed). Release sharply into the sunset listening closely for the Megow Hummer buzz over the cheers of the crowd. Another happy modeler is born.

So, no matter what form of Old Timer turns you on—miniature or full size, glow or ignition—these models still have that special appeal that makes me wish I had been there during the "Golden Age" of modeling.

JOHN BURKAM ON HELICOPTERS

Hotshot Airplane Pilot Goes Helicopter: Dario Brisighella joins the growing list of expert RC pilots who have been hooked on helicopters. Look out Dieter Schluter! His excellent pictures show the beautiful workmanship and design improvements on the SSP-DB which Dario, with Gene Rock's valuable advice, has come up with. Latest word from Dario is that, after learning all the maneuvers that Gene and I can do, he is practicing hovering with the model facing toward him!

Dario offers two helpful hints: (1) Buy aluminum sheet, rivets and aircraft nuts and bolts from the Fixed Base Operator at your local airport. When clued in on what you're making, they often go out of their way to help you. For aluminum bar stock, look for job shops that work in aluminum, ask if you can buy drop-offs, floor sweepings. The latter often include valuable tools as well as nuts, screws, washers, etc. (2) To obtain low speeds on your bandsaw for metal cutting, back it up to your metal cutting lathe, put a small pulley in the chuck and run a belt from that to the bandsaw. Lathes have a variety of low speeds and all it costs is possibly a longer belt and a metal cutting bandsaw blade, available at industrial hardware stores.

Kavan Jetranger Demonstration: Ed Sweeney tells me that its performance using collective pitch is breathtaking. From a hovering condition, nose it down 45°, pour on the coal, and it sweeps forward and up just like a real one. However, the extra control may pose new problems. Not only must throttle and collective pitch be coupled together, but it would probably help to couple in the tail rotor collective also. With our throttle-only type control, a sudden change in throttle produces a momentary torque imbalance as a reaction to accelerating the rotor. After that, torque is

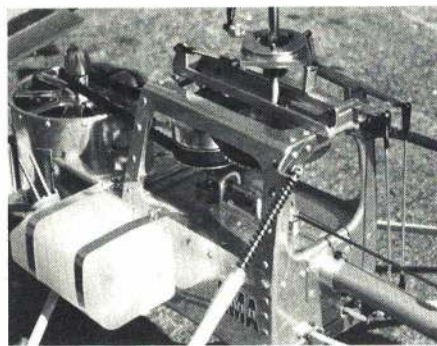

Note excellent workmanship, sheet metal work.



Successful SSP helicopter by Dario Brisighella made from plans in the August issue with many improvements by Dario and the designer Gene Rock.

again balanced because main and tail rotor both change speed proportionally. With collective pitch and throttle coordinated, there is probably a smaller transient torque unbalance but a sizeable steady one after the change. The electric operated yaw rate gyro in the Kavan chopper damps out the small transient yawing motions but not the steady large ones. Nevertheless, I intend to try out collective pitch on my helicopter—with both throttle and tail rotor coupling—at the earliest opportunity.

Stabilizing Gyros: These same rate gyros, if used to sense pitch and roll rates and inject the proper signals into the pitch and roll servos, could be used to stabilize helicopters with articulated rotors such as Sikorsky, Hughes, Enstrom, and even Boeing-Vertol tandem choppers! Those with teetering rotor and no stabilizing bar such as Bell Jetranger and Fairchild-Hiller FH-1100 could now be completely scale. On articulated rotor helicopters (those on which the blades have flapping and lead-lag hinges), one would have to be careful to avoid ground resonance or mechanical instability. This condition occurs when the aircraft rocking frequency on its landing gear is equal to rotor speed minus blade lag natural frequency. Lag frequency is usually about 0.3 times rotor speed, so make the landing gear frequency different from 0.7 rotor speed.

On Looping Model Helicopters: If you know the drag of your model in equivalent flat plate area, you can calculate how fast it must go to coast through a circular loop of a certain diameter by using the formula:

$$V_i = \sqrt{\frac{V_f^2 (W + A_f [P/2] \pi Rg + Rg W)}{W - A_f [P/2] \pi Rg}}$$

where V_i = initial velocity, fps; V_f = velocity at top of the loop, fps; W = weight of model, lbs; A_f = equivalent flat plate area, sq. ft.; P = mass density of air, slugs/cu. ft. (.002378 at SL); R = radius of loop, ft.; g = acceleration of gravity, ft./sec. (32.2).

This formula assumes for simplicity that drag decreases linearly along the arc from bottom to top of the loop. Examples: For a velocity V_f at the top, of 5 mph (7.3 ft./sec.) a seven-lb. helicopter with 1/2 sq. ft. of flat plate area would have to go 38 mph to do a 40 ft. dia. loop, or 26 mph for a 20 ft. loop. If its flat area were decreased to 1/4 sq. ft. by streamlining it would have to go 36.6 mph for a 40 ft., or 25.5 mph for a 20 ft. loop.

Next Month: How to measure your chopper's speed by tape recorder and drag by rotor tilt.

JOHN BLUM ON CL CARRIER

The Two-line Burper: As previously discussed, one major problem of the two-line, pre-load throttle system in Navy Carrier was the inability to make throttle adjustments from the handle during flight. To gain the advantage of less drag by the elimination of one wire, compared to the conventional three-line system, the method dictates a pre-set high speed and a "loaded" or spring actuated system of achieving low speed. Following the high-speed flight, the throttle actuator is triggered perhaps by extreme elevator, and the throttle linkage moves to a pre-determined position for slow speed. A method to "clean out" the engine if it tended to "lead-up," or the need for a burst of high-speed throttle to correct flight attitude, was evident. Thus, the advent of the "burper."

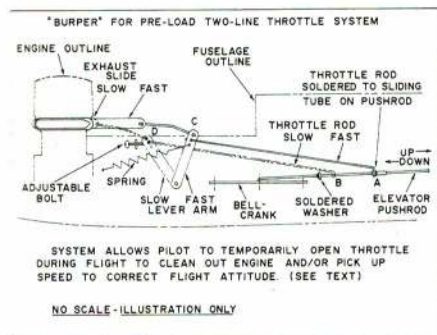

The sketch illustrates a basic setup. It is not drawn to scale and should be used for illustration only. This sketch does not show the throttle triggering system. The throttle exhaust slide and lever is typical with the addition of a spring, lever-stop, throttle rod, and a washer soldered to the elevator pushrod. The throttle rod is attached to the lever, with the other end soldered to a bushing that slides on the elevator pushrod. (Continued on page 96)

BUD TENNY ON INDOOR

Indoor Flying Opportunities: Indoor sessions will be held at the MIT Armory, at the corner of Vasser St. and Mass. Ave., Cambridge, Massachusetts on February 17 and March 17, 1973. An Indoor contest is planned for April 14, 1973. Contact Ray Harlan (15 Happy Hollow, Wayland, Mass. 01778) for more information. Indoor Contest near Kansas City, planned third Sunday in February 1973. (Roger Schroeder, 4111 W. 98th St., Shawnee Mission, Kan. 66207.)

Care and Feeding of Rubber Bands: Rubber-powered Indoor models are very sensitive to variations in power level—more so than outdoor rubber models which unwind their motors before landing. The indoor model is powered from takeoff to landing, and poor rubber or poor application of good rubber has a drastic effect on flight performance. To state the case another way, the flier with poor technique and good rubber will have both good and poor flights, but the flier with good techniques will get consistently good results regardless of rubber quality.

Turns, Torque and Prop/Rubber Match: Three important items of technique in flying rubber-powered indoor models are: Proper turns, proper torque, and matching the prop and rubber to the model and flying site. Of these, the prop/rubber match is by far the most important. In terms of results, a good

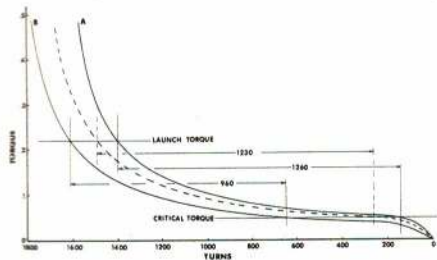

(Continued on page 101)



SSP-5

Gene Rock presented in AAMI's July and August issues of last year the successful original version of this model. Since then, many many SSPs were made and improvements developed. These improvements supplement the original plans still available through the plans service. No additional plans are offered.

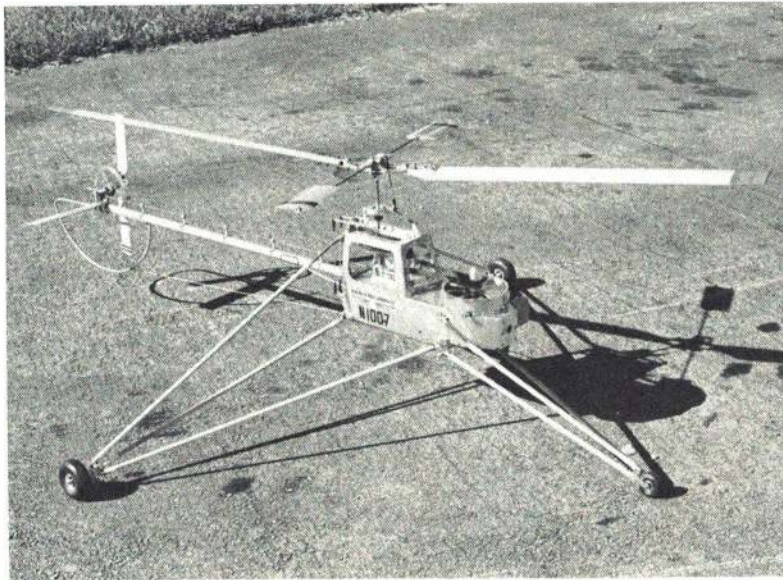

Brisighella's model illustrates many of the latest improvements discussed by Gene Rock in this article and shows some alternate construction methods and shapes. It flies great too. A unique idea is to cover the RC compartment with clear stiff plastic for instant visual inspections.

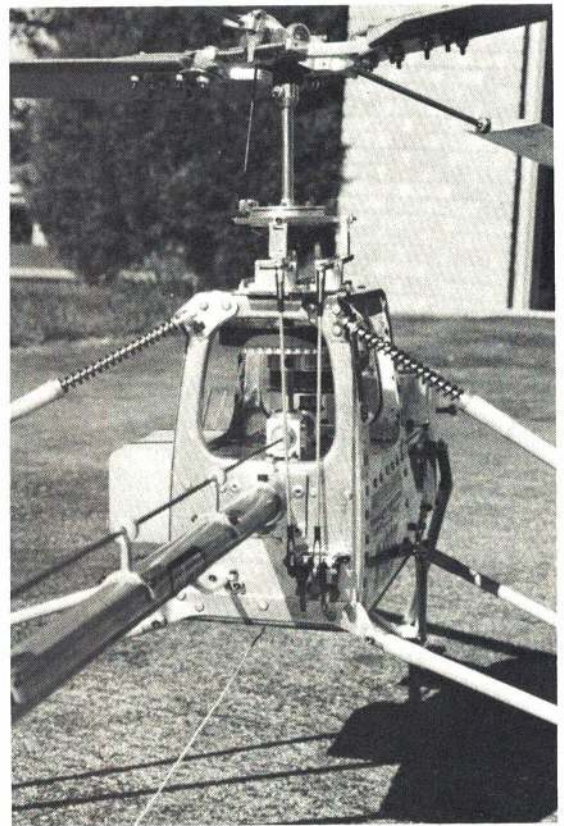

Since the last documentation of the S.S.P. (August and September AAM) there have been four basic revisions. Three of these revisions existed by the time the article was published.

The first major change came about a year ago with the ultimate goal of incorporating a semi-scale fiberglass fuselage. When flying in cold weather, the tail rotor belts lost some of their elasticity and were therefore slipping. When the original plans were drawn, larger belts were incorporated to meet with the manufacturer's suggested belt tension. These larger belts, however, were never added to my model because they would have been in the way of a fiberglass fuselage.

To make a fiberglass fuselage feasible, the following changes were made. A gear drive tail rotor was incorporated along with an extra gearbox to change the direction of the tail rotor drive shaft. The gears in the change of direction box were two pinions from a 2:1 bevel set. The side struts came off next because they were in the way. After several experiments, a spring-loaded flap hub was found to make flying easier, especially in a wind. The old hub was discarded because of the difficulty in the addition of springs. In a fit of ambition, aluminum paddles were shaped to replace the wooden ones and weights. Not only did they look better, they worked better and last a lifetime.

A sub fin and a strap-on large rudder were added to enable better visibility in flight. Surprisingly my hovering ability was also improved because of this addi-

With many SSP's
under construction and flying,
here are the designers latest
improvements for easier building
and better performance.

GENE ROCK

tion. The horizontal stabilizer was moved out of the downwash of the main rotor in order to lighten the nose weight.

After all of these changes, the fiberglass fuselage was found too heavy (it cut into my reserve power), and therefore discarded. Well, I still had a more scale-like model.

The extra gear box was discarded next because of added complexities and weight penalty. It was replaced with a speedometer cable about three in. long and the complete drive shaft was installed inside of the tail boom with Rulon bushings supporting the shaft every six to eight in. Two of the supports were on each end of the cable. The model was then flying well... I thought. (Boy, was I in for a surprise.) The model was flown extensively, which brought up some more problems. The model fell out of the sky many times because of fuel starvation and an incorrect setting of the air bleed on the carburetor. During some of the hard landings, the sub fin would break its bond to the tail boom. There also seemed to be an interaction from the cooling fan

when the model went into forward flight. An extreme amount of nose weight was required to counteract the downwash of the fan. With this CG $\frac{1}{2}$ to 1" forward, the model would pitch nose down when applying power and nose up when decreasing it.

The next revision solved the problems discussed above. The sub fin was attached with three sets of rubber bands rather than bonding. A fuel reservoir was incorporated and the air bleed closed. (This doesn't mean that all Enya .45s need their air bleed completely closed.) Next, a centrifugal cooling fan 2 $\frac{1}{2}$ " in dia. was tried with a shroud. Because of the belt drive, the blower could be only $\frac{1}{2}$ " deep. The blower did not give adequate cooling, therefore by sizing what I had, I decided that the blower needed to be as large as four in. in dia. Since the original SSP had a 4 $\frac{1}{2}$ " dia. axial blower—too small for a 90° day and full power—I decided to use it with a shroud. By choking the outlet, the 4 $\frac{1}{2}$ " dia. fan was sufficient. The problem of the interaction of the fan was over. The CG was then moved back to $\frac{1}{4}$ " in front of the rotor shaft. An integral rudder was incorporated and the next flying session indicated that scale-like skids could be added. The model was then flying like a dream. You could take your hands off the controls, reach out and touch the model in flight. What could be better?

The SSP was next flown in the Boeing-Vertol wind tunnel three weeks before the Nationals in Chicago. This test, among other things, brought out

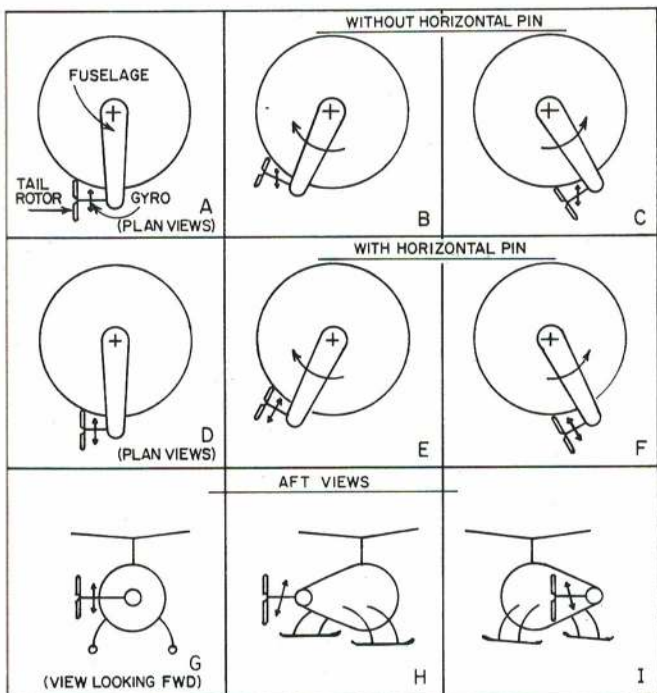
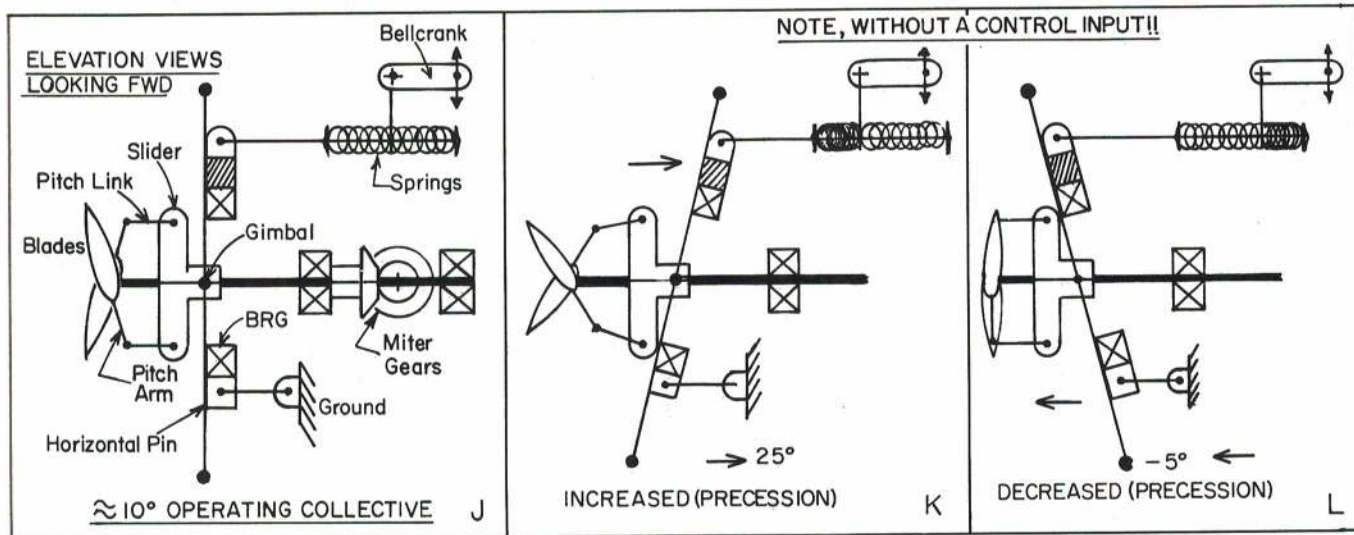

These drawings illustrate the most significant and unique aspect of the SSP helicopter. All torque or wind-gust inputs to the yaw axis are compensated for by the tail rotor's mechanical gyro. Drawings tell how it works and illustrate the mechanical operation clearly.

Below: Shroud controls air-flow from the fan to really cool the Enya 45. Murphy muffler also featured. Electric starter always used.

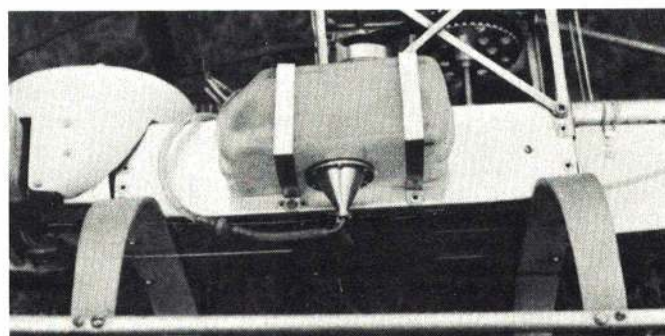
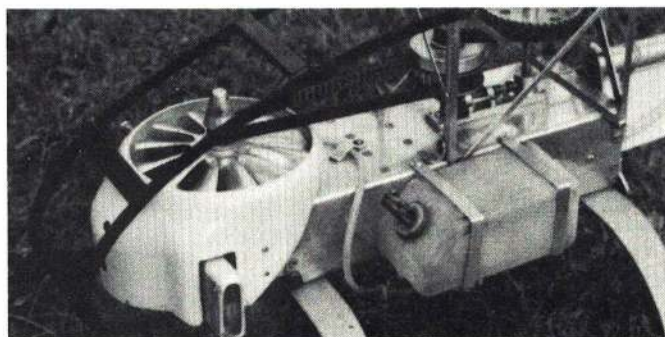

Right: That sump prevents fuel starvation with a fore-and-aft tank arrangement. Pilot experienced several power failures before this was added.

Below Right: Tail rotor drive is taken through miter gears from clutch shaft. One piece shaft drive and support plate holds four ball bearings.

Below: Study complete control linkage and swashplate system. Specially made parts used throughout. Rotor head is as on original plans.

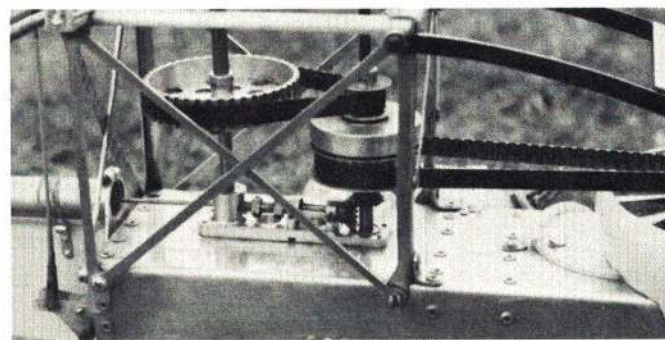
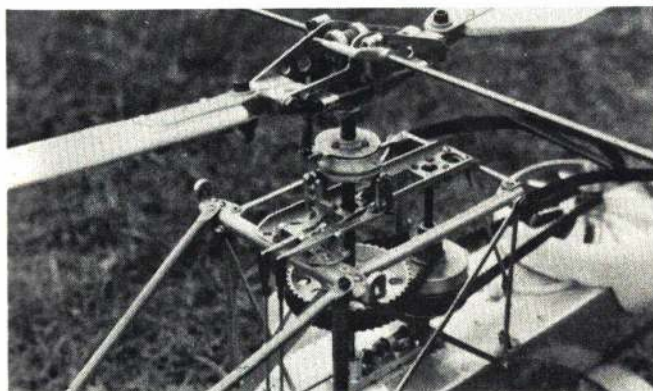

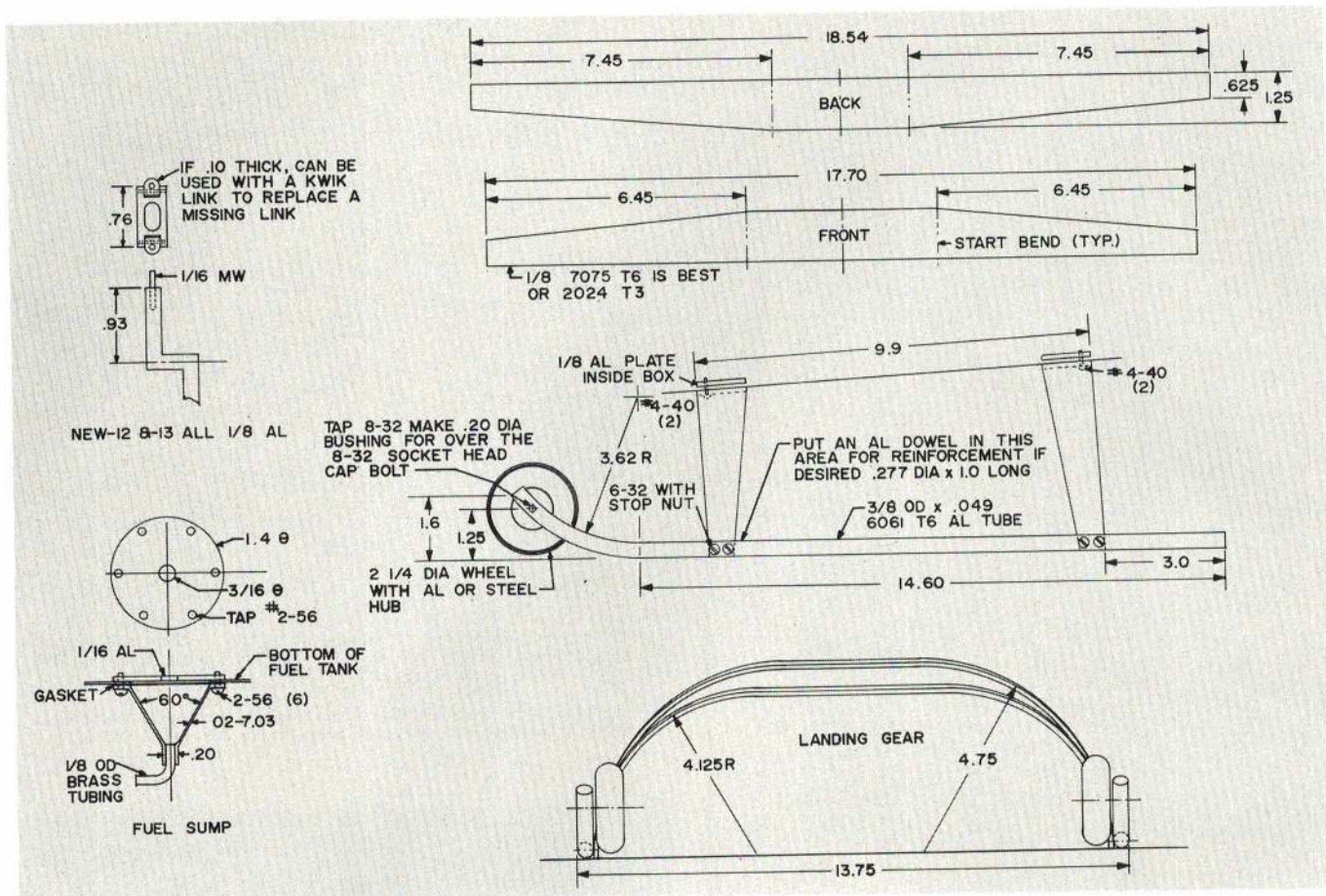

the 0° collective setting to the bottom surface of the paddles. The test came off with barely a scratch—was I lucky, flying in a 20 by 20' room with a thirty mph wind!

At the Nationals, the model flew very well, but the change of altitude and air temperature left me somewhat short on maneuvering power. The tail rotor hit the ground in a couple of hard landings, the sudden shock to the speedometer cable would double it over. It was very hard to hover in a crosswind in the windy city.

After the Nationals, the cable was replaced, and power loss tests were conducted. These tests concluded that because of the small bend radius in the cable and the fact that the cable was supported on each end by a bushing instead of a bearing, the tail rotor was taking twice as much horsepower to drive as normal.

The last revision took shape in the form of a straight out tail boom (negligible power loss). The rudder was reduced to 31 sq. in., approximately half its former size. The model then had more power and was easier to hold in a crosswind. In the last couple of weeks, the horizontal stabilizer was moved back to its position shown on the original plans. The reason for this was because the model would not fly forward naturally without holding forward stick. The horizontal stab would come into the downwash of the main rotor when the model reached five to ten mph. This would cause the model to pitch up

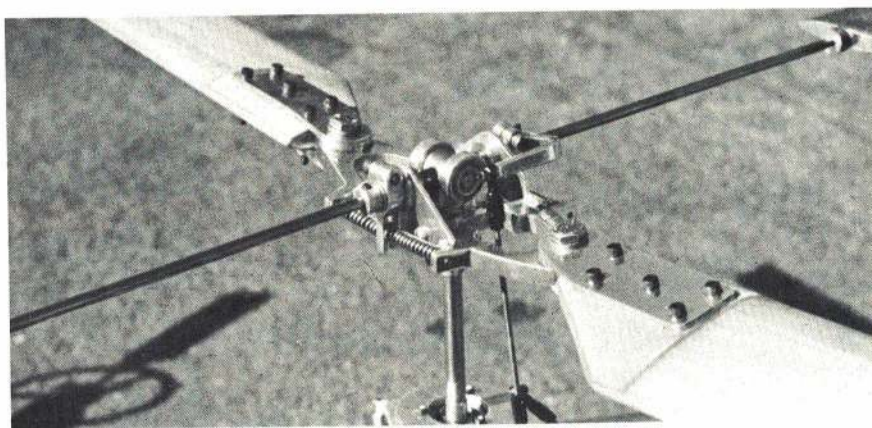

Brisighella's model again showing Rock's new rotor head system. It is very much simpler and more trouble-free than the original. It is based on a cut and shaped piece of hard 1/4 in. aluminum rather than multiple pieces and parts of sheet aluminum. Below: The tail gyro, like all other parts of Dario's model is beautifully made and works like a charm, but it takes careful adjustment of the many forces involved in its operation.

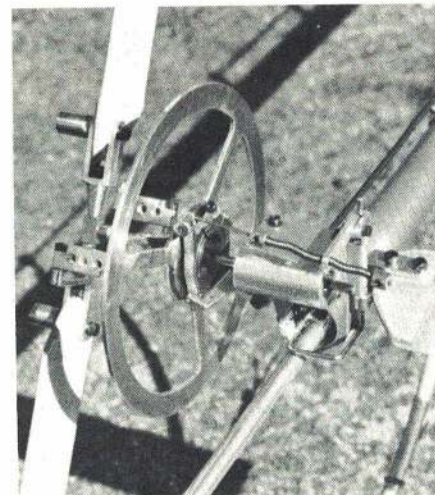

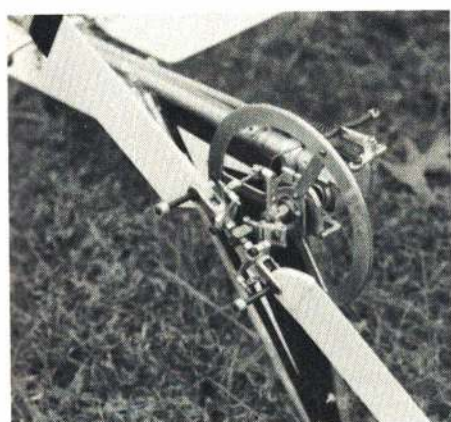
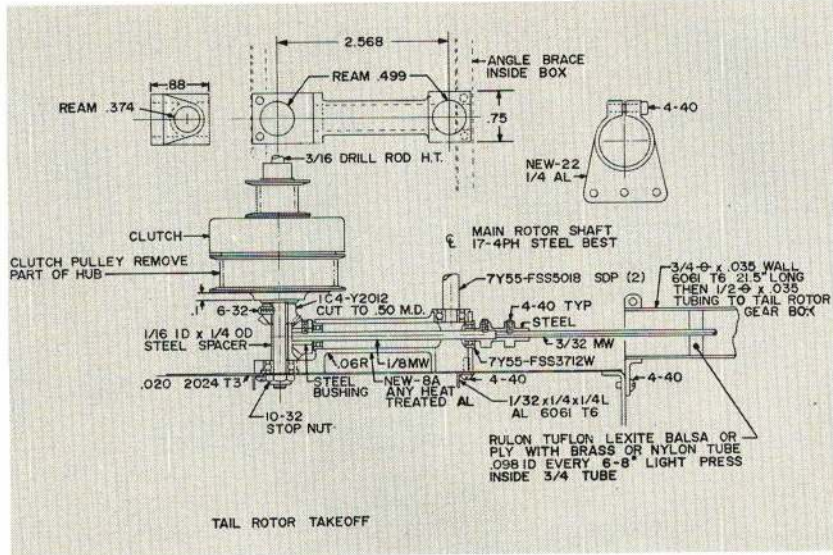
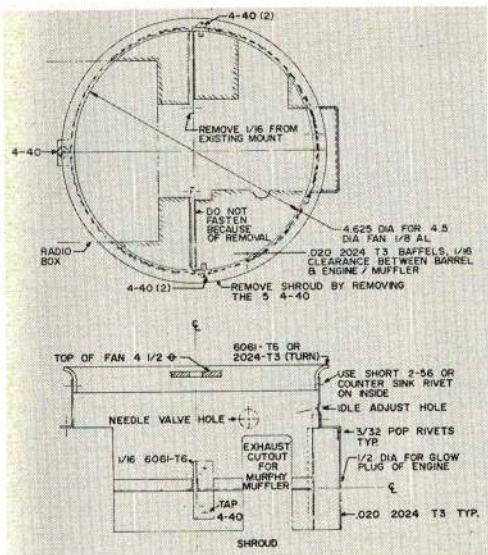

SSP is still the only model helicopter with gyro on tail rotor. Text and drawings show how it works, pix show its looks.

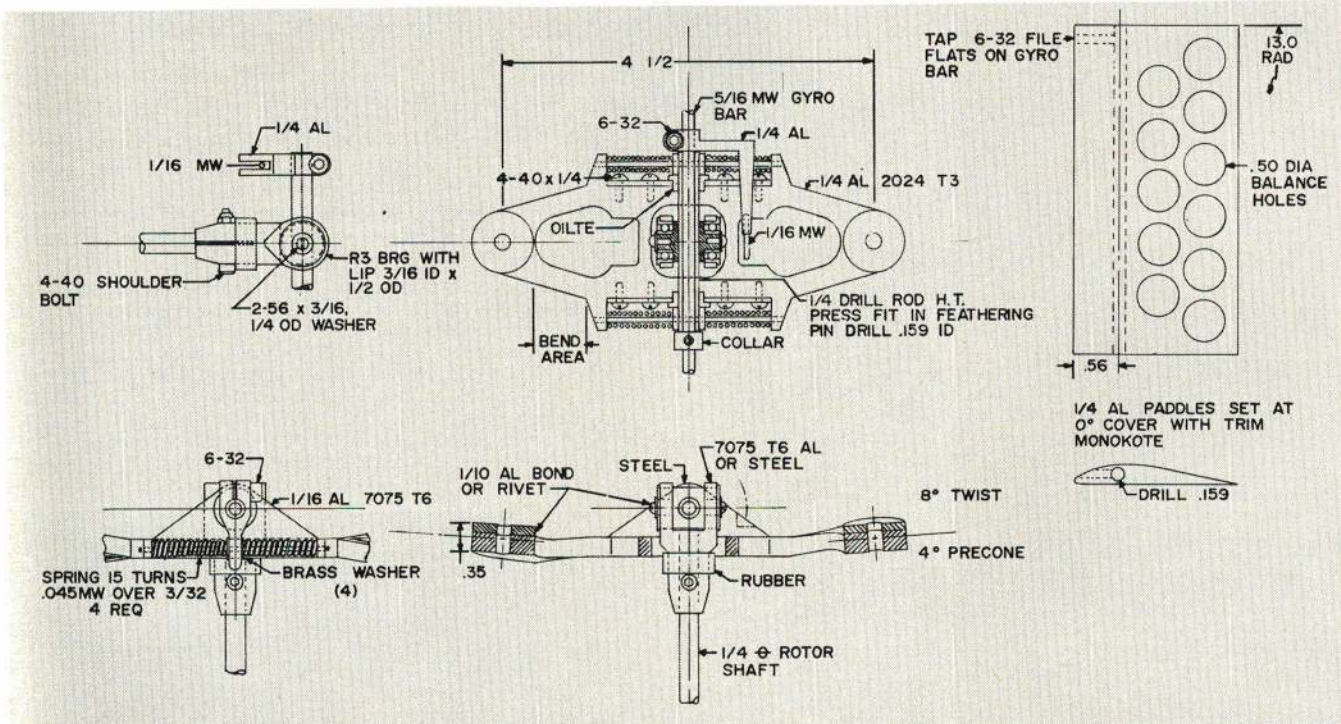
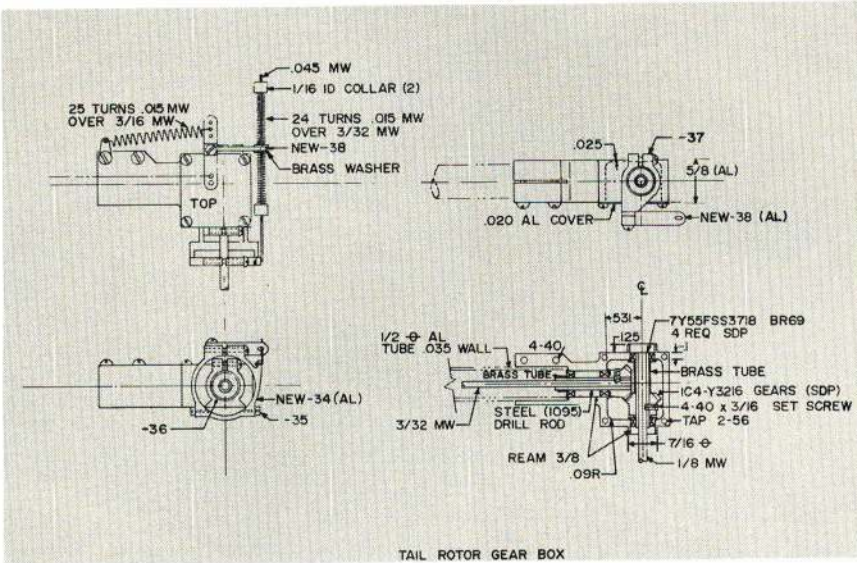

A Magnificent Flying Machine for .60 engines

Lancer

SL-62

\$39.95



KIT FS-30 SPAN 62" LENGTH 50" AREA 700 SQ. IN. FLYING WGT. 6¼ LB. ENGINE .60

A Contest-Caliber Sport Flyer

The Magnificent SL-62 is the result of 2 years' design and testing to meet the "if they had only made it this way" suggestions directly from the R/C Flyers in the Field. The result is this 62" Span beauty which has fulfilled expectations and aroused great enthusiasm with the R/C Flyers who have seen and flown the test models. Collective engineering-design is reflected in the fast and easy way the SL-62 goes together, and the flying . . . well, you've just got to take the Stick to believe it; it's that good.

Finest Quality materials include Prime Grade, Density-Selected Balsa sanded to micrometer tolerance. Imported Birch Plywood, etc. Fuselage features Die-Cut one-piece full-length sides, Plywood doublers (that go past wing for maximum strength), five Bulkheads—accurately Die-cut; combined with shaped Nose and Cowl blocks, quickly

go together to make a sleek strong fuselage; Topped off by a jet-shaped Canopy. Rugged custom made Aluminum Engine Mounts make engine installation a pleasure and formed music wire Tricycle gear includes fully-sprung stress relieved Nose gear.

Unique table-top construction insures a warp-free wing, a must for top performance. Wing parts are Die-cut, shaped, etc., to insure fast accurate assembly; and Balsa Sheet covering keeps warps out, resulting in a light rugged wing. Tapered strip Ailerons provided, are simple to install using the new ready-to-use simplified Aileron linkage units. Wing assembles to fuselage with nylon screws in hardwood nut-block provided, in the unusually complete Hardware pack which includes all the special nylon R/C fittings required. Rudder and fin are sheet, Stab is built up and sheet covered to keep it permanently flat.

STERLING MODELS • BELFIELD AVE. and WISTER ST. • PHILA., PA. 19144

If no dealer available, direct orders accepted—with 10% additional charge for handling and shipping. (60c minimum in U.S., \$1.25 minimum outside U.S.)

- Catalog of entire line of airplane control line model kits, R/C scale and Trainer kits, boat model kits, accessories; etc. 25c enclosed.
- "Secrets of Model Airplane Building." Including design, construction, covering, finishing, flying, adjusting, control systems, etc. 25c enclosed.
- "Secrets of Control Line and Carrier Flying." Including preflight, soloing, stunting, Carrier rules and regulations, Carrier flying hints and control line installation instructions. 25c enclosed. No checks. Only U.S. money orders or currency accepted.

Name _____

Address _____ City _____ State _____ Zip _____

Sterling
MODELS
INC.
PHILA., PA. 19144, USA

Take a Good Look at These.....

Fabulously-Authentic Super-Detailed

"Stick Model" Kits

THEY'RE FAMOUS

Piper Cub Super Cruiser is a classic 3-passenger light plane of the forties, and an old time modeler's favorite.

- Citabria made by Bellanca — a real aviation pioneer, is the sleek, powerful, modern light plane, a familiar sight at many airports
- Curtiss P-40 Warhawk. Work horse of World War II, made immortal by the Flying Tigers in China and Burma.

THEY'RE UNIQUE

Because such amazing detail scale authenticity is achieved with kits that are relatively easy to build. Plans include 3 views of full size Aircraft and show how to install movable controls from cockpit. Authentic color scheme shows on full color kit box lid.

THEY'RE VERSATILE

Kits can be built 6 different ways: Rubber powered, as supplied, then using 020, 049 or CO₂ for power: Free Flight, Control Line, R/C (with pulse or single channel) for static scale. Any way makes a museum-like model.

THEY'RE EASY TO BUILD

Just about every frame member is accurately Die-cut from the finest quality Balsa Wood, sanded to micrometer tolerances . . . and every part is numbered to insure fast and accurate assembly as shown on easy step-by-step plans.

THEY'RE COMPLETE*

Highly detailed plastic parts included, simplify the assembly and add a genuine touch of realism-in-miniature. Covering material, pre-formed wire parts, wheels, authentic decals, hardware pack that includes control system parts; is a partial list of the contents of these fine quality kits.

* Dry Kit. Rubber power material supplied.
Other power and equipment not included.

THEY'RE AT YOUR DEALER

GET OVER AND SEE THEM NOW . . . BUY ALL THREE

STERLING MODELS, INC. PHILA., PA. 19144



SPAN 35½"
SCALE 1"=1'.0"

**KIT E-6 PIPER CUB
SUPER CRUISER 7.95**
12 Pack — 15 lbs.



SPAN 33½"
SCALE 1"=1'.0"

KIT E-5 CITABRIA 7.95
12 Pack — 15 lbs.



SPAN 27"
SCALE ¾"=1'.0"

KIT E-4 P-40 WARHAWK 7.95
12 Pack — 16 lbs.

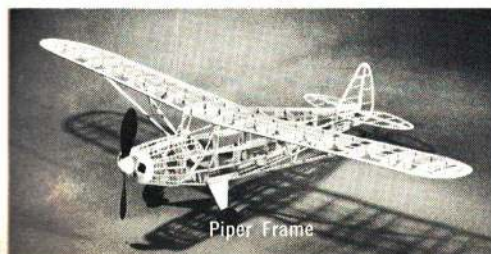

Piper Frame



Citabria Frame

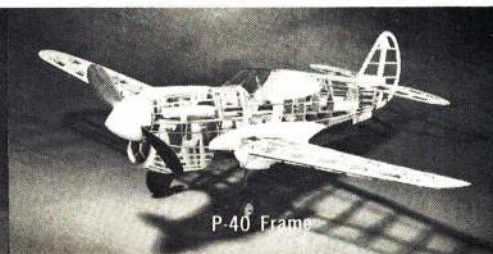

P-40 Frame

NEW PRODUCTS CHECK LIST

FRANK PIERCE



Terry Plane/Thor II. For the novice and sport flier, *Thor II* flies well on 15 to 29 power in spite of its large 62" span. For one-, two- or three-channel, kit comes complete with accessories, full-size plans, instruction book. Built-up balsa construction, clear canopy. \$28.50. Terry Plane Inc., Box 2429, Orcutt, Calif. 93454



Orbit/Great plans. Starting business before the carpenters are out, Orbit is already expanding, only six months after they returned to private ownership and the guidance of experienced model builders. The new facility in Santa Ana has filtered dust-free air for clean, precision manufacturing of trouble-free RC products. Here we see Charles Speers (left) handing a '73 prototype through the framing to John Elliot. Stand by for further releases from the new address at Orbit Electronics, 1641 Kaiser Ave., Santa Ana, Calif. 92705



Squadron/Signal Publications. F4 Phantom. A detailed 48-page text of all pertinent facts and data for the great Phantom II. From 1953 when McDonnell designed the plane as the AH-1 single-seat fighter to the present F4-J—everything is included. Performance records, squadron assignments, armaments, combat descriptions. A hundred or more photos should be a real aid to the serious scale modeler. \$3.95. Squadron Signal Publications, 3515 E. Ten Mile Rd., Warren, Mich. 48091



Salem Industries/Electric fuel pump. High-quality fuel pump operates on 1½- to 12-volt DC source, pumps 12 oz. of fuel in 12 sec. at 12 volts. Reversible, constant displacement, pump is fully assembled with hoses, filter and wiring. Backed by a four-year guarantee. \$19.95. Salem Enterprises, Mandia Lane, Goldens Bridge, N.Y. 10526

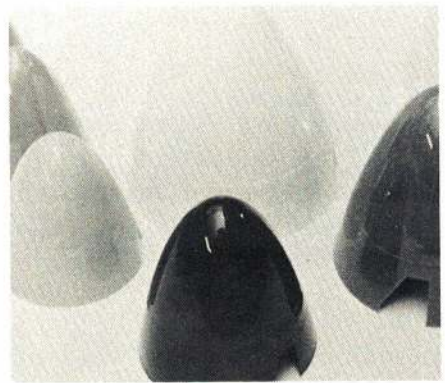

Williams Bros./Twist Lock Spinner. Shown are some of the array of spinners in the new line from Williams Bros. Eight sizes from 1½" to 3½". Made of nylon cast in six colors. Internal opposed cam lock locks under rotation from either direction. Screws hidden for good scale applications. Up to \$5.45. Complete catalog available for 25 cents. Williams Bros., 181 B St., San Marcos, Calif. 92069

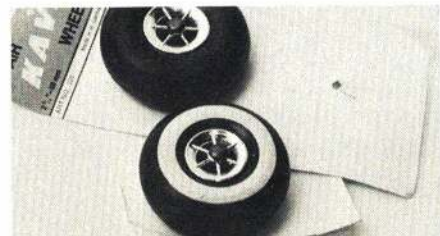
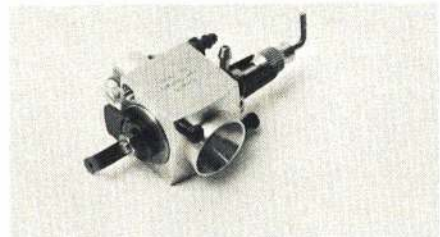

Kavan/MRC/Pressure carburetor and air wheels. Pressure carburetor, made in Germany, is available for all popular engines. \$22.50. Also: Series of air wheels, scale blackwall, from 1¾" through 3", \$1.80 to \$3.05/pair. "Broad whitewalls," same size, \$2.30 to \$3.60. Complete MRC catalog lists Kavan, Enyas, Webras, RC systems, 25 cents. Model Rectifier Corp. 2500 Woodbridge Ave., Edison, N.J. 08817



Midwest/Motor Sailplane. From Germany, the *Graupner AS K14* uses foam/balsa-planked wings and tail surfaces, fiberglass fuselage and formed canopy. Recommended for 15 engine with four-channel RC operation. Span 90½" length 41", wing area 687 sq. in. Flying weight approximately five lbs. Full decals and hardware in kit. Excellent instruction manual. Midwest Model Supply Co., 6929 59th St., Chicago, Ill. 60638



Du-Bro/Muffler. A new-design muffler in which quieting and back pressure can be adjusted by the number of baffle plates installed. Plates easily installed and removed. Shown is unit for Webra 60 RC. \$7.50. Du-Bro Products Inc., 480 Bonner Rd., Wauconda, Ill. 60084

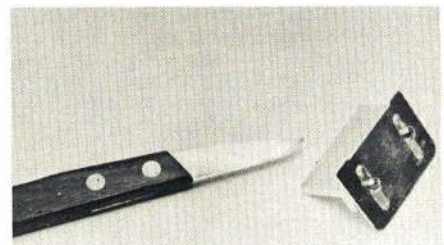

Tatone/Slot-Cutter. A precision tool for cutting hinge slots. Guide can be adjusted as required to center cutting slot on any sheet from 1/16 to 5/8". Special knife makes cut and then clears wood shaving from finished slot. \$2.95. Tatone Products, 1209 Geneva Ave. San Francisco, Calif. 94112

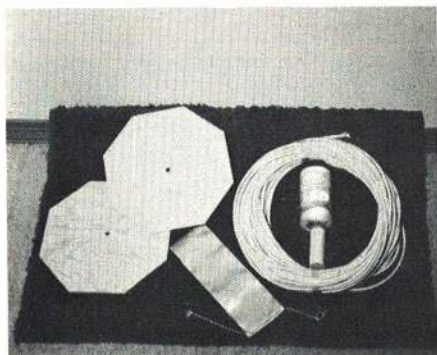

Ridgewood Hobby/Easy-up Launcher. For use with sailplanes up to five lbs., "High Start" uses 536' of 75-lb.-test braided nylon cord, 3/16" cloth-covered exerciser cord, flag, hardware, and storage reel. 600-ft. launches can be easily achieved. \$19.95. Ridgewood Hobby Supply, Box 2045, Vernon, Conn. 06066



AHM/KwikCote. In rolls 26' x 78", KwikCote is a highly reflective, high opacity coating with excellent strength-to-weight ratio. Thermally applied with warm iron, coating comes in a wide range of standard colors plus other hard-to-get shades such as silver, Cherokee brown, transparent red and orange with still other colors to be released. Imported from England. Associated Hobby Mfrs., 621 Cayuga St., Philadelphia, Penn. 19120

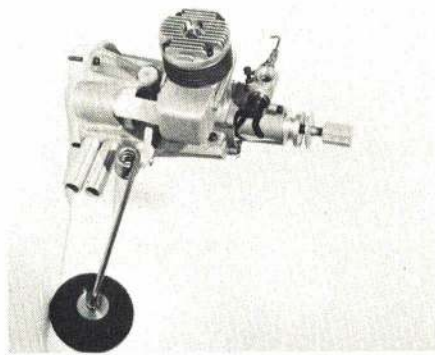

C.B. Enterprises/Muffler Mount. Cast aluminum engine mount includes chamber and baffling to muffle exhaust from engine. Manifold attached to engine flows exhaust into chamber, two outlet tubes route the quiet mess out the fuselage. Manifolds available for O.S.60, Webra 60, H.P.61 and New Veco 60. Mount has bushing for nose gear with upright or side mount position of engine. Tentative price, \$24.95 for Muffler Mount and \$5.95 for manifold. C.B. Enterprises, 21590 Cloud Way, Hayward, Calif. 94545

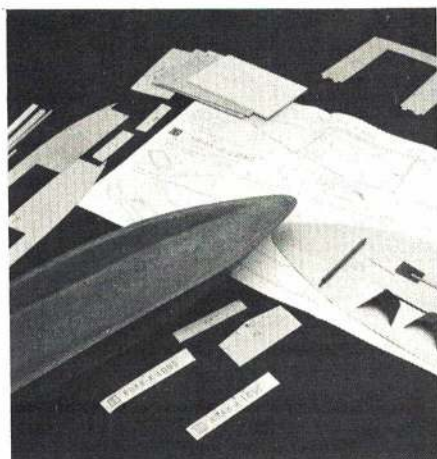

XL-ent Products/Power boat. From England, *Krak-A-Long* has fiberglass hull, pre-cut hardwood deck planking and superstructure. Complete kit includes rudder, U-joint, engine mount. 029 power, 10 1/2" beam, 28" length. XL-ent Products, Rt. 25A, Rocky Point, N.Y. 11778



Guillows/P38. Built-up balsa construction model of famous twin-engine WW II fighter can be flown free-flight or UC, rubber-powered or with 049 engine. Formed ABS-type plastic scale parts include rockets, bombs, supercharger, cowling, etc. adds to scale appearance. Retractable gear, canopy, cockpit details, CL handle, nylon flying lines all mark this kit as an outstanding value, 44" span. \$18. Paul K. Guillow, Inc., Wakefield, Mass. 01880

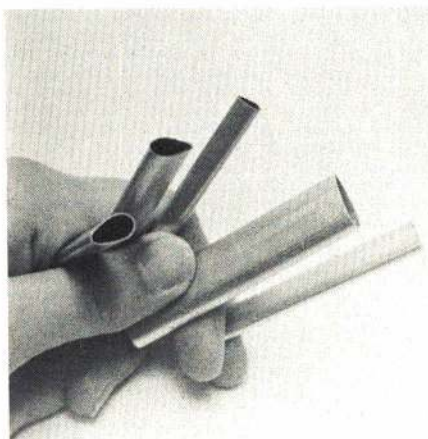

K&S Engineering/Streamlined tubing. For the ultimate in scale realism, K&S now markets five sizes of airfoil-shaped aluminum tubing. Ideal for landing gear, cabane or interplane struts, etc. Reduces drag on non-scale models, too. 1/4, 5/16, 3/8, 1/2, 5/8" sizes, measured front to back. Write K&S Engineering, 6917 W. 59th St., Chicago, Ill. 60638

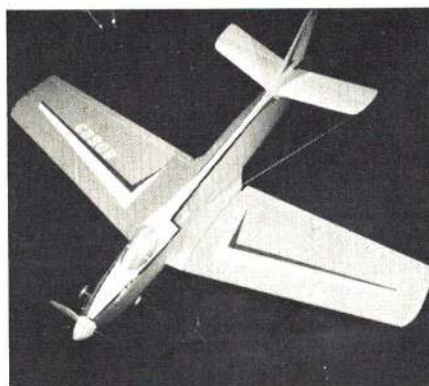

RC Kits/Super Hunter. A full-house stand-off scale model inspired by British Hawker Hunter jet fighter, winner of best design competition at Pontiac, Michigan. Fiberglass body, 62" span foam wings, 60 power, 7 to 7 1/2 lbs. flying weight. \$69.95. With skinned wing and stab, \$89.95. RC Kits, 353 Briar Ave. N. Canton, Ohio 44720



Heuer/Stop watch. For all kinds of meets and competitions where accurate timing is a necessity. Watch has large 2.5mm distance between increments for easy and accurate reading of tenths of a second, minute counter at bottom of dial. Shockproof, micrometer-adjustable. \$69.50. Heuer Time and Electronics Corp., 960 S. Springfield Ave., Springfield, N.J. 07081

**TELL THEM YOU SAW IT IN
NEW PRODUCTS CHECKLIST**

K&B 15 SCHNURLE PORT ENGINE DON JEHLIK

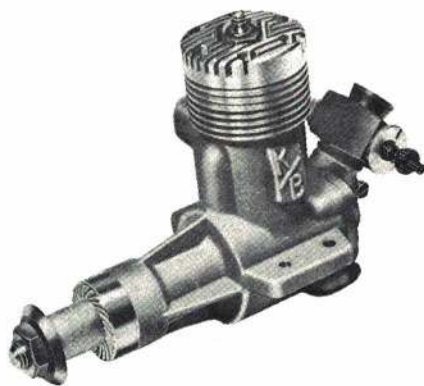

For readers information, all engines used in AAM Tests will be taken apart, examined and small corrections made as needed prior to any running. These will be the minimum number of corrections the average contest flier would do himself to ensure that the engine is ready to run. Checks for loose bits of metal, binding or improperly made parts or errors in assembly are typical. No special work, fitting, etc. will be done.

Special work on engines and tests performed for absolute performance from them will NOT be covered by this column; it will be covered by technical articles elsewhere in this magazine.

The K&B 15 RC engine is the first U.S. production made Schnurle port engine. Bill Wisniewski of K&B pioneered this type engine design nearly a decade ago. Since then, with the exception of Supertigres and the Rossi 60, engines built by Bill or influenced by his designs have dominated where horsepower counts.

Why include this in a writeup about an RC engine? Bill noted several years ago that a Schnurle port engine would be ideal for RC. Lower fuel consumption, higher power, and remarkably smooth running due to the port design are characteristic of this type engine.

Test results bear out Bill's observations. Equipped for RC operations with a Perry carburetor, the engine was a pleasure to run. First runs were on Supersonic 100 fuel. This engine starts per instructions, and will, hot or cold.

A look at the graph will show carburetor characteristics and the power of this engine. With an output of .36 hp at 16,000 on Supersonic 100 it is the equal of current RC 20s.

Now I've done a couple of things with the graph. Recording torque from 3,500 to 16,000 on the recommended prop (7 x 6) and fuel shows carburetor response. Then I've noted hp at a typical peak rpm while running on the ground (.36 hp at 16,000) and checked it out at a "highest" reading (.41 hp at 20,000). This represents power available at maximum conditions on the recommended prop.

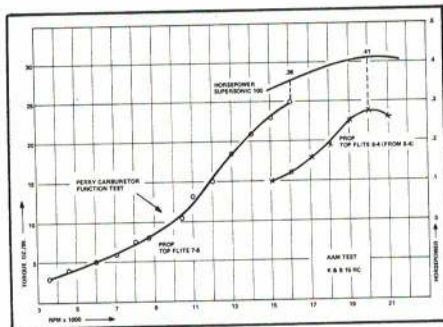

PRO-LINE COMPETITION SIX FRED MARKS

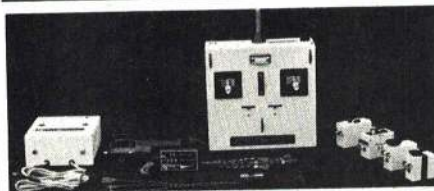

The Review Set: The PRO-LINE COMPETITION SIX. Six channels, two stick, open and closed gimbal. (Both transmitter styles tested). Tested with six D&R linear servo-mechanisms, PRO-LINE servoamplifiers.

Features: IC servo amps and IC decoder. Plug-in transmitter and receiver RF modules permit operation on any of the available frequencies. Very high transmitter output (600 milliwatts radiated). Extreme precision open gimbal sticks. FET receiver front end. Buddy box for training is standard. Toggle-switch control of one channel for retract gear. Transmitter antenna completely retracts for storage. Four stages of receiver IF for good selectivity. Diode back-up permits operation with one cell open. Transformer isolated dual-output charger. High-rate charger optional. Three-wire servo.

Tests: Temperature stability 0°F to 150°F satisfactory. Flight tested during the entire 1972 contest season in AMA demonstration Bearcats with excellent results. Servo resolution, see figure. Other test data, see table.

Evaluation: An excellent set, well designed and well built. Servo current drain was excessive and necessitated use of heavy duty, 550 mah cell (actually derated from 800 mah) for the airborne pack. As a result of these tests, PRO-LINE has "desensitized" servo resolution slightly to reduce drain, permit use of standard 450 mah pack. Servo resolution is the best evaluated to date.

Characteristics

Dimensions*: Transmitter—6-5/8W x 6-1/2H x 2T; Servos**—1-1/8L x 1-3/4H x 7/8W; Airborne Battery Pack (four 550 mah cells)—2-1/4L x 1-7/8W x 1T; Total airborne weight (with four servos, 550 mah pack)—Approximately 13 ounces; Transmitter Output—600 milliwatts; Receiver Sensitivity—1 microvolt**; Servo Thrust—2.7 lb. at 7/32 radius; Servo Torque—in.-lb.—.6; Servo Transit Time—sec. (end-to-end)—.05; Frame Rate—75/sec.; Control pulse width—1.5 ms + 0.5 ms.

* Dimensions—inches; ** Length includes mounting lugs; height includes output arm; *** Mfrs. data.

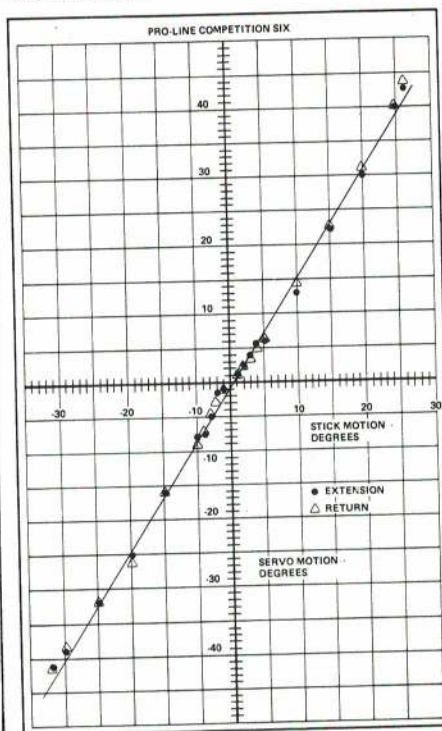

AIRBORNE ASSOCIATES HI-LO PAT MURPHY

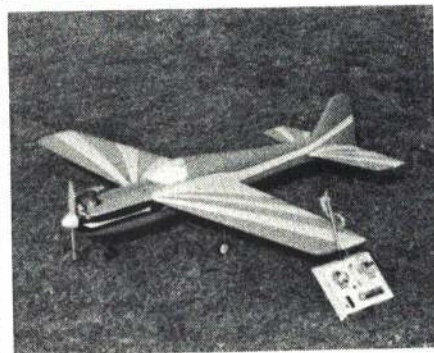

Probably the hardest task for a competition flier is to achieve consistently straight and true, and identical airplanes. This is the reason Airborne Associates developed this all-fiberglass plane. The fuselage is laid-up fiberglass produced by Skyglas of Tennessee, the wings and stabilizer are produced in California by A.R. Flight (Glaskin), and the wood parts are cut for the kit by Joe Bridi. The fuselage has detents in the skin to help the builder get perfect wing and tail alignment. The firewall and motor mounts are installed in the fuselage on jigs.

Among the goals of the design were: Roomy fuselage for proper and easy equipment installation, including the retracts; a particularly distinctive-looking model at a time, in contest flying, when so many models looked alike; some realism; and of course, competition flying caliber.

The design goals were achieved with a unique fuselage shape. The nose is the widest part of the body. It is so wide that a Ross twin could be completely encowled and a side-mounted Webra would be almost hidden. It is a shoulder wing plane but unlike any other design the stabilizer is located low on the fuselage. Hence the name Hi-Lo. The fuselage tapers neatly toward the stabilizer leading edge then flairs gracefully into the rudder and stab mounting area.

Hi-Lo doesn't buffet and bounce around in high or gusty wind and it will fly hands off up or down wind without trim changes. When inverted only slight down elevator must be held to keep level flight, so rolling maneuvers need very little elevator pumping when rolling to the inverted position. The fuselage shape helps the rolls too. Little or no rudder is needed at the second and fourth points of the four-point roll or during slow rolls.

The airfoil used is somewhat unique and is designed so that at low speeds an increase in angle of attack will increase drag without a large increase in lift. It won't stall suddenly or snap-roll.

The instructions on building and trimming the Hi-Lo included in the kit are in the form of a very complete twelve-page manual. The fuselage is available in standard form with nose cutout for upright engine position. On special order a fuselage without cutouts can be obtained so that you can side mount or invert the engine. The Glaskin wing and stab have the retract cutouts or slots for fixed gear mounts already made. The process for making the Glaskin stabs was developed specially for the Hi-Lo; I believe these wings and stabilizers are the strongest available.

Be sure to balance the plane both for fore and aft (CG) and laterally (wingtip-to-wingtip). The throws indicated in the instructions seem small, but they give the plane very fast response. I reduced mine by another 25%. This makes the plane a very smooth flyer.

Hi-Lo was designed to: (a) Use easy to install retracts—both mechanical and pneumatic. (b) Have either upright or sidewinder engines. Mine have had Webra 61s, but several other of the new design engines are equally as strong. (c) Be an extremely fast airplane and should fly about 100 mph with a good engine.

The Hi-Lo should weigh about 7 1/2 to 7 3/4 lb. and will fly like a much lighter plane if you read and follow the instruction manual. It was designed by George Hill and Col. Hank Walker to be a competition airplane, and it is just that—competitive. You can build two, three, or more, all identically because of the kit engineering by Bob Scott.

“Have Fun . . . Build, sail or fly these Exciting Models”



Mod Pod
54" wing span \$16.50

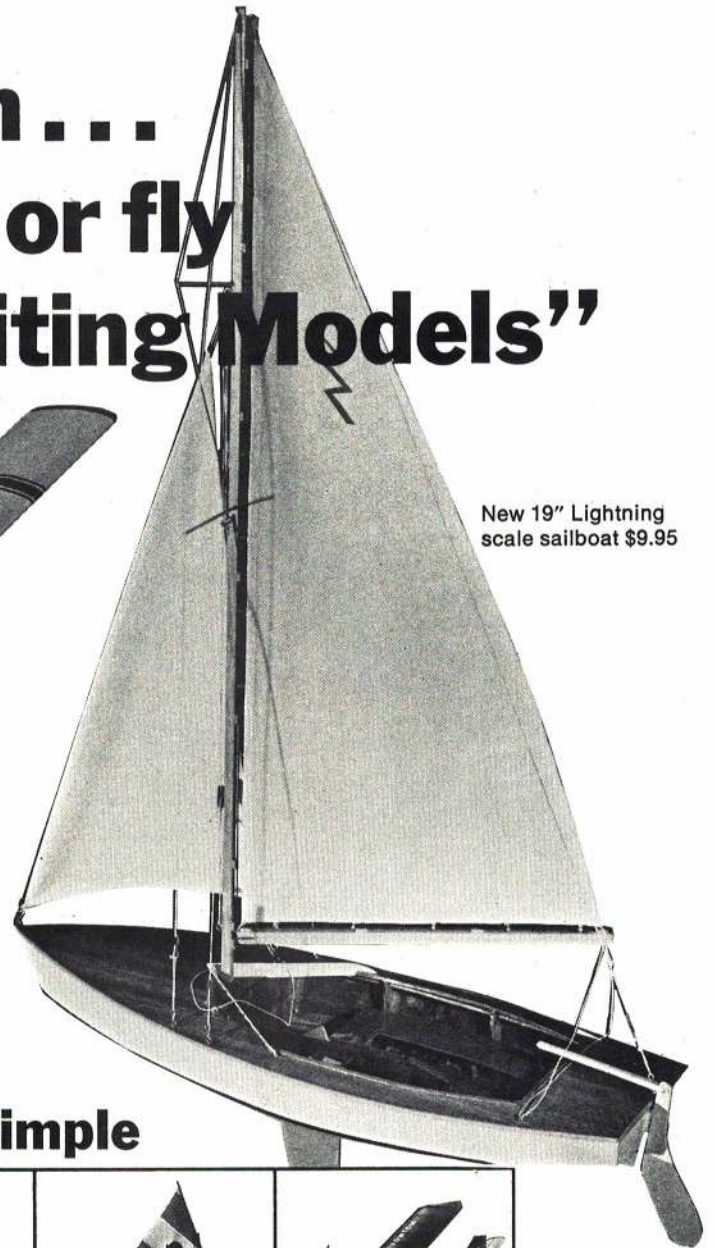

New 19" Lightning
scale sailboat \$9.95

Inexpensive . . . Simple

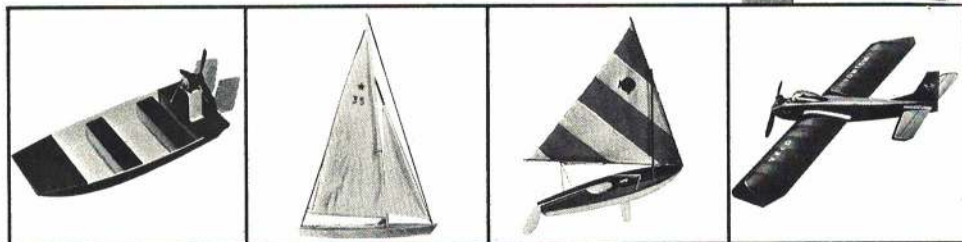

Little Jon \$3.95

30" Star \$30.95

Sunfish \$11.50

Tom Tom \$9.25

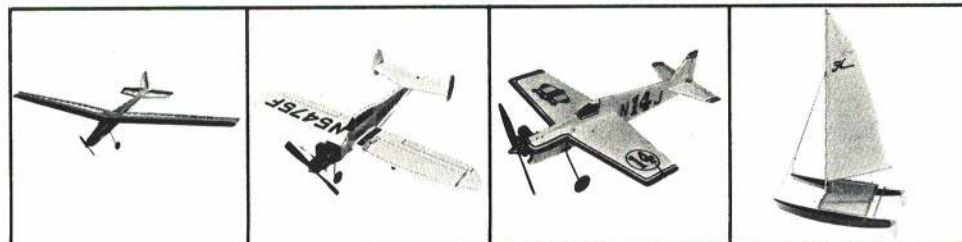

Evolution 2 \$14.95

Mooney Cadet \$4.25

Lil Tiger \$4.50

Hobie Cat \$6.50

We're pretty well known for our record breaking RC competition planes and boats . . . also for our line of "Veco" Ukie kits . . . our popular Evolution RC all purpose plane and our scale model boats.

. . . All this experience and know how goes into all our fun kits, too! Send 25¢ for our complete catalog of models, hardware and accessories.

Dumas Products, Inc., 790 S. Park Avenue, Tucson, Arizona 85719

BOB STOCKWELL ON RC

Pylon Controversy: During the latter part of the 1972 season the pages of the NMPRA Newsletter, the house organ of the National Miniature Pylon Racing Association, were filled with controversy. Most of the controversy surrounded basic issues in pylon racing and appears to have resulted in some reasonable measure of clarification of the rules and improvements of the potential of the sport.

The issue which caused most controversy was the horsepower problem: The fact that a relatively small number of competitors seemed to have a significant edge in horsepower with the K&B Schnuerle. Toward the end of the season, fliers like *Kent Nagy, Bob Smith, Chuck Smith, Larry Leonard* and a few others were consistently in the 1:20s, with the best time posted at the B.I.R.D.'s race being 1:23.4 by Kent Nagy in late October. I'm not quite sure how much faith to put in the times at the B.I.R.D.'s race, however. They threw out all of the Saturday times because the course turned out to be 25 feet short (they were turning 1:18 and 1:19 pretty regularly). Then on Sunday, with the full-length course, the early times were still very fast but some of us began to wonder about how precisely the cuts were being called at the scatter pylon. So, with the permission of the CD John Elliot, I went down to stand under the pylon and help the guys pick up the cuts. It turned out when I talked with them that (a) someone had instructed them (not the CD) that if they dropped the flag for a plane, they could not thereafter wave a cut—i.e., they could only wave a cut if the pilot turned before they dropped the flag. They interpreted this to mean that they could not call a cut even if the pilot turned back inside the pylon. And since they had been leading their pilots on the flag drops, there had been quite a few cases when in fact the cuts were not called. So we made some changes. I stayed under the pylon, and the flagmen and I together signalled the cuts. The flagmen stopped leading the pilots, dropping the flag only when the plane actually reached a point even with the pylon. And they started flagging cuts whenever I indicated that the pilot had turned back inside the pylon.

After that the times were still pretty fast—around 1:26, for the best ones—and they were absolutely legitimate times. But Bob Smith, for example, had a cut at the scatter pylon in each of his next two races, once pulling about ten ft. short, the other time cutting sharply back just inside the pylon. And as a consequence he took third place: The first Southern California race he failed to win all season long.

I confess that my own view of pylon cutting is that if the plane is so close to the pylon that you're not sure it cleared, then it's a cut! In theory, the pylons represent a pole going straight up to the clouds; therefore even a wingtip over the pylon constitutes a cut, since the wingtip would clip that pole if it were actually there. I suspect that the times would not be so spectacular if everyone took very seriously the question of going around the pylons, not over them or just inside them. A few more tough-minded pylon judges should be able to make the times a bit more comparable around the country. If there were some reasonable way to do it, I'd like to see a metal pole—say a half-in. pipe—extending up from the top of the pylons about 20 or 30 ft. Then I'm sure everyone would fly a little wider around the pylons. At least they would after the first race of the season, if there were any airplanes left. Why don't we try it?

Now back to even more controversial issues, in particular the horsepower race. Right at the end of the season, again the B.I.R.D.'s race, *Terry Prather*, with one of *George Aldrich's* screaming Supertigres, demonstrated that the Tigre is still competitive even with the Schnuerles. He turned a 1:23.8. That was before the pylon cut situation got straightened out, however; I know that Terry was moving very competitively, but I'm not quite persuaded that the time was really that good. Unless the Bologna factory comes out with a Schnuerle-ported screamer, or unless *George Aldrich* pulls another miracle with his modifications of the Tigre or the H.P., I think most of the 1973 competition will be between K&B production engines, expected out in quantities exceeding a thousand by May.

Another area of controversy is the



Winners of the Pop White Memorial races, sponsored by the FAST Club at Mile Square, S. Cal. From right to left: Larry Leonard, Whit Stockwell, Bob Smith, Clarence Neufeld and Jeff Bertken, first through fifth.



Pappy deBolt's Formula II Caudron. Pappy ran away with the National Competition in Formula II/FAI. Pappy retired as NMPRA VP after many years of dedicated service.

NMPRA Season Championships. In spite of the new system, which was devised to eliminate the edge that large contests gave to the Southern California fliers, there was considerable feeling that the points from one area to another were not, and cannot be made, comparable. So once again the proposal of a *Tournament Of Champions In Pylon Racing* is being discussed. In fact, the new VP for the Southern California District, *Chuck Smith*, pledged in his pre-election platform statement to work toward bringing about just such a race for the end of the 1973 season. The new NMPRA President, *Ed Rankin*, had not as of this writing indicated his position on this issue, but I have little doubt that he would be in favor of it. Rankin has, by the way, indicated very strongly his disagreement with the way in which pylon racing is scheduled at the Nationals, and we can expect him to negotiate very strongly with the Nats Executive Committee for a different kind of setup for pylon racing, in which everyone who comes to fly pylon will be assured of at least six flights even if he doesn't make the finals (as compared with three flights under the old qualifying system).

JOHN SMITH ON CL

Correction: In the November '72 issue I reported that the winning Rat Racer (NATS) was set up by Bill Keller. Bill did do the job on his own Open winner but Norris Sparks set up the Senior winner. Sorry about that Sparkey. But you both are members of the BOSS RAT RR Team, aren't you? Sure you are.



Bill Keller of the BOSS RAT team, winner in the Open Rat Class pits for Bernie Varnau (also of the BOSS RAT team), who took first place in the Senior category. Good pit action makes the difference.

It's What's Up Front: New engines greet the New Year. First in line is the new Thermo-Jet jet engine. Fueled with propane, and fired up with a propane torch, this looks to be one of the most interesting of the new entries. Although too large a tail pipe for AMA competition in its manufactured form, the installation of a tube restrictor will put the tail pipe legal sized. Thrust is three lb.-plus in its stock form but this should be easy to increase. This is a valveless design, so fuel will have to be



Thomas Conelly and his son Bill (Petersburg, Fla.) prepare their Goodyear racer "The Owl" for flight (Navy photo.)

played with to really make it move. It can be run on liquid type fuel too, so I'll keep you informed on the testing being done on the sample I was sent. Fuel consumption is in the area of four oz./min. running (propane). Should be interesting.

A new diesel from Supertigre is now available from World Engines. Based on the lower end of the new X15 FAI engine, the diesel uses a side stack setup with large bypass area. Only running time will tell how much extra power will be developed with this added bypass and should show if the fuel consumption will suffer. The ST X15 is also now available from World Engines. This is a copy of the engine that won the last FAI Speed meet. A new AMA FAI record was set using one of these engines—154+ mph. It should be an interesting summer coming up.

Don't be surprised if at least one overseas manufacturer comes out with a new three port .40 shortly. The new TDs (.049) should be on your dealers' shelves now, too. The main change is better quality control in the manufacture of these already fine engines along with a new head design to boost the power a little higher. Dale Kirn makes a whole bunch of goodies to help make these engines easier to run. His fine thread needle valve is like day and night when it comes to tuning one of the Coxes. 128 threads to the inch really lets you sneak up on the setting.

Answer Your Mail: Received a letter from a fellow from Australia telling me he and his buddy have written to Speed fliers and suppliers in the U.S., sometimes enclosing international money order coupons to pay for return postage and catalogs. Never a reply. Let's not ruin international good will by not answering these people. After all, they can't go to the local hobby shop and pick up what we can here. So come out of your shell and drop these guys a letter if they wrote to you.

AMA Reviews CL Safety Report: The Perry-Randell report on line pull made over 12 years ago was finally reviewed by AMA. I don't know why the delay, unless this was done during AMA's rough years and was just put back and forgotten until now. Everything these two guys claimed as far as pull was concerned has come to pass and all their formulae have been proven over the years. Reports are that selected fliers will be asked for their test reports based on the P-R tests. Finally, maybe we'll get this line size-pull test problem finished. We all will have to come up with new subjects for hangar talk though.

Prop Cases: Ever carry props loose in your tool box only to find chipped edges or even broken blades? Do you dig through a pile of props trying to find the size you need in a hurry? Well, here's a cheap carrier that will take props up to eight in. and by stacking them, you can add length to them.

What is it? A potato chip can! The new chips called Pringles come in a solid can three in. in diameter x eight in. long. A snap-on plastic cap seals it. Each can will hold a bunch of props. And the chips are good, too.



MID-WING MINNOW

If you think you're seeing double, don't sweat it: When Larry Leonard (shown here), Ron Schoor, Terry Prather, and Roger Owens build back-up airplanes, they are identical. Beautiful, every one of them. At meets as many as six sets of "twins" show up.

Hobby Shack

price no longer indicative of quality

CIRRUS Hobby Shack

SIX

SIX CHANNELS, TWO STICK
27 OR 72 MHZ.

6 CHANNEL TRANSMITTER, 6 CHANNEL RECEIVER,
FOUR RS-5 SERVOS, NICADS, CHARGER, SWITCH
HARNES AND SERVOS TRAYS.

\$219.00

*INTEGRATED CIRCUITS / *VERY LOW BATTERY DRAIN / *2 WIRE BATTERY PACK, 3 wire SERVOS / *FULL 90 DAY WARRANTY, serviced at World Engines or Hobby Shack / *BUDDY BOX / NICAD BATTERY! / *12 volt TRANSMITTER



If you have shopped around for your new radio, you have most likely asked yourself "why is there such a big price difference in different radio systems?". We at Hobby Shack can understand why one perhaps answers that question in thinking if it cost more it must be better. NOT TRUE! It's true you can spend more, . . . but you cannot buy better quality than our CIRRUS SIX.

How can we do it then? Simple! We are a national mail order company that sells thousands of different hobby supplies and we do not depend solely upon selling radio control systems. The Cirrus Six would normally sell for a lot more, but not being totally dependent upon these radio sales alone, we do not have to have a high profit in selling our system.

The Cirrus has the most up to date features as most other system and in fact, more features, than most. IC (integrated circuits) chips, bridge type amplifier, small servos, light weight airbourne, all nicads, 12 volt transmitter, buddy box, attractive looking, handy carrying handle, 3 wire servos, 2 wire battery pack, quality, reliability, six channels, 90 day warranty and a price tag of \$219.00, and now we service our product at our warehouse location. We have all the specialized electronic equipment and a factory trained electronic technician who will do warranty work and repair. If World Engines is closer to you, they also will do warranty and repair service.

Taipan

.21 (3.5cc)

Schneurle Ported
Twin Ball Race

RETAIL
\$36.95

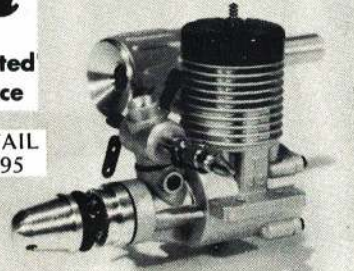

\$29.99

\$34.99 With Venturi
Flow Thru Muffler.

The crankshaft is suspended by front and rear ball bearings, Extra large, heavy-duty mounting lugs and Schneurle ported (3 port induction for maximum rpm's!). 3.5cc Legal for cars and boats (.21, 3.5cc)

Precision Engineed Engines



.09 DIESEL	\$16.95	OUR PRICE \$13.67
.15 DIESEL B.B.	\$28.50	OUR PRICE \$22.67
.15 R/C GLOW.	\$24.95	OUR PRICE \$19.96
.15 STD. GLOW.	\$15.95	OUR PRICE \$12.76
.21 STD. PLANE B.	\$18.95	OUR PRICE \$14.88
.21 R/C PLANE B.	\$29.95	OUR PRICE \$23.88

new from
MIDWEST **MACH I**
SLEEK PATTERN
SHIP
reg. 49.95

\$39.99

\$79.99 with
O.S. 60R/C

SPAN: 62"
AREA: 725sq.
DISP: .60 cu."

FACTORY AUTHORIZED BLUE MAX SERVICE CENTER

As of the first week in January we at Hobby Shack are happy to announce that we now offer factory service and repair.

All the specialized electronic testing equipment is here for the proper repair of your radio control system.

TELEPHONE (213) 522-4921

Midwest SUPER CHIPMUNK & TAIPAN 15 R/C -COMBO-

NEW



\$49.90 VALUE!

SALE

\$36.99

A Beautiful, all foam, stunt and sport trainer. Span: 46". Mount the Taipan .15R/C up front and . . . easy flying!

MUFF-L-AIRE

NEW DUBRO



The New neater looking and contest proven DuBro muffler for the Webra .60

No. MW-750 retail \$7.50

Model MU-7.95 fits a variety engine sizes. retail \$7.95

\$6.29

\$6.66

Joe Bridi's RCM BASIC TRAINER & TAIPAN's .15R/C COMBO



A beautiful trainer with a 50" wing span for Sunday fun with lots of power from Taipan's .15 R/C !!!

\$36.88

REFUELING AND Shut-Off VALVE



Pressurized or nonpressurized systems. Mounts on side of plane. Re fuels directly to tank, turn valve to shut off engine . . . no flooding when off!

\$5.95

7 amp STARTER WET CELL AND CHARGER



With this powerful 7 amp wet cell you will never again worry about your battery going dead or growing weak causing hard starting. Once charged, you will always have a hot plug start month after month. Charger is included.

\$5.99

Pilot JR. BOX FLY & TAIPAN 15R/C COMBO!



a real quickie with 46" foam covered wings, diecut ply. fuselage Retail \$42.90

\$29.90

MIDWEST U/C PROFILES & O.S. 30 STD. COMBO! Choose from the MUSTANG, KING COBRA, and the MESSERSCHMIDT. All are for .29 to .40 engines and have a 48" wing span, 504 sq" area. For slow combat and sport & fun flying. Beautifully shaped and notched leading and trailing edges. With the fine O.S. 30 standard engine, \$31.45 Value!



\$21.99

The RCM BASIC TRAINER and the FOX .40R/C Combo!



RCM Trainer for a 4 channel system. 58 1/2" wing span, kit includes all hardware, Plus you get, the famous FOX .40 R/C engine

\$49.90

V.K. CHEROKEE BABE and the O.S. .35R/C !!!



Here's a real beauty with a 54" wing span and is a real stable and fun flyer for the sportflyer with 4 channel radio gear. Plus . . . the proven O.S. .35 R/C engine.

\$35.80

Hobby Shack

New Taipan



FLYING REEL

\$1.75

5" diameter, molded plastic flying handle.

One of the most practical flying handles we have ever seen is this TAIPAN flying reel. It's a 5" flying handle complete with lead out wires that your flying lines can be attached to. To adjust the lines, simply loosen the wing nut and move lead out, and then secure wing nut by tightening. When you're through flying, wind the lines onto the flying reel. For engines up to .29.

Hobby Shack HEAT GUN

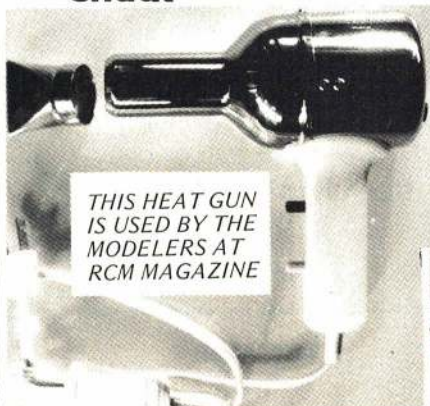

THIS HEAT GUN IS USED BY THE MODELERS AT RCM MAGAZINE

What can you say about our heat gun? — except that it's priced right, . . . and it will do the job! The heating element is ideal for both *Monokote and *Solarfilm and its sturdy construction will hold up year after year.

OUR PRICE
\$12⁹⁹

CIRRUS CONSIDERING THE QUALITY \$69.99 MAKES IT THAT MORE REMARKABLE.

That's right the Cirrus 2 channel is loaded with features that at \$69.99 makes it seem unbelievable. Several years ago when the two channel outfits were introduced in order to keep the price down it was more economical for the manufacturers to put two servos and one receiver in the same case. The Cirrus has two separate mini D&R Bantam servos. Even though it cost more our price is lower than the bricks. We made it that way to sell better!

The System has three IC (integrated circuits) chips, one in the receiver decoder and one in each servo amplifier. Considering that our Cirrus (in a matter of 60 seconds) can be converted so the left stick has a ratchet action for throttle control. Considering that most are weight conscious, the Cirrus 2 weighs 7½ ounces with batteries and about 6½ oz. with our .250 amp nicad pack, which is optional. Now consider that our current drain is so low with the IC chips one can fly all day on .250 amps without a worry. Why not consider our Cirrus 2 for your radio control system.

2 CH.

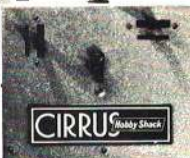

- *SMALLEST SERVOS
- *LIGHT WEIGHT
- *VERSATILITY
- *2 STICKS

Plus full 90 day warranty serviced by Hobby Shack

\$69.99
Add \$10.00 for 72 mhz.



- YOU CAN DO SIMPLE SOLDERING
- YOU HAVE SOME MECHANICAL ABILITY, LIKE USING A SCREW DRIVER
- YOU WANT TO GET INTO RADIO CONTROL AT THE LOWEST POSSIBLE PRICE
- YOU WANT A FULL 6 CHANNEL SYSTEM

YOU WANT OUR DEAL ON THE BLUE MAX MARK II IC 6 CHANNEL SEMI-KIT.

WHAT A DEAL ON A SIX CHANNEL SYSTEM. It comes complete with four assembled S-S servos, semi-kit transmitter, semi-kit receiver, charger, all nicad batteries, servo trays and switch harness. In the semi-kits, all components are FACTORY soldered to the PC boards and are then FACTORY checked before being sent to us. Simply finish the interwiring assemble the boards and your about done. A step by step building manual assures quick and easy assembly.



\$167⁹⁹

new from TAIPAN GLASS FILLED NYLON PROPELLERS



SIZE AND PITCH	RETAIL	OUR PRICE	BUY THE DOZEN
Prop 7X6	75¢	59¢	\$5.90
Prop 8X4	\$1.00	79¢	\$7.90
Prop 8X6	\$1.00	79¢	\$7.90
Prop 9X6	\$1.25	99¢	\$9.90

TRUE PITCH for extra power (you would be amazed to find that most nylon propellers do not have the same pitch at every station as the size designates). GLASS FILLED NYLON doesn't flex or warp causing a loss of power or engine vibration, because they're BALANCED FOR SMOOTH RUNNING, blades on both sides are exactly the same in length and thickness. EFFICIENT BLADES AND AIRFOIL right down to the hub. FIELD TESTED!

SEMI SCALE CHAMPION CITABRIA



Hurray and at last! Our first Hobby Shack kit is ready and what's especially exciting is it's a sporty fun, fun airplane at a realistic price. With a Cox T.D. .051 to an O.S. Max .10 the CITABRIA has been designed to be the most docile, stable good looking trainer planes around. For you more daring aviators, place a good .15 up front (like a Taipan) and hang on! It will really move out doing rudder rolls; inverted flight, Cuban eights, loops, spins, and other aerobatic maneuvers that a good Champion CITABRIA should do.

The CITABRIA has been designed for fast easy construction and comes complete with High Quality Die Cutting of plywood and balsa parts, full size plans, shaped landing gear and hardware. With a little extra work you may want to add wheel pants and a spinner (options on the full size one) and trim it with the scale sunburst on the top wing. It would easily pass for stand-off scale. We're showing a photo of an actual Citabria because our ad deadline is here and our four prototypes were built quickly and not painted nicely

SPAN: 43"
AREA: 290s"
DISP: 051-15
/ 1 to 3 Chs.
\$9⁹⁹



(714)
522-4921

Call This Number For The Fastest, Easiest Way To Order From The HOBBY SHACK!

WE'RE OPEN 7 DAYS A WEEK AND EVE'S TOO!
Call or come in a shop . . .
STORE HOURS am to pm
Monday-Friday .9 to 9
Saturdays . . . 9 to 5
Sundays . . . 10 to 3

Local shoppers, we are close to all the freeways, between, the Santa Ana and the Riverside Fwys corner of Knott and 8th street.

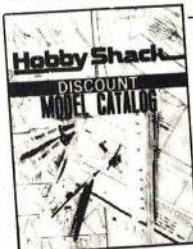

- *Finest U/C & R/C Catalog Available
- *Fully Illustrated
- *Plan Construction Photos For Popular Kits
- *Accessory Chart For almost every plane for needed hardware, tanks, tires, etc.
- *Easy To Read—Easy To Order From!

I enclose \$1.00 for your fully illustrated modelers catalog. Please rush it to me today!

MAIL THIS COUPON TODAY; TO:
HOBBY SHACK
6475 KNOTT AVENUE
BUENA PARK, CALIFORNIA 90620

NAME _____
ADDRESS _____
CITY _____
STATE _____ ZIP _____
CALIF. Residents add 5% Sales Tax
POSTAGE & HANDLING

Orders to \$ 5.00 add \$.90 \$20.01 to \$30.00 add \$2.50
\$ 5.01 to \$ 8.00 add \$1.00 \$30.01 to \$50.00 add \$2.75
\$ 8.01 to \$15.00 add \$1.20 Any Order
\$15.01 to \$20.00 add \$1.60 Over \$50.00 add \$3.00

6475 KNOTT AVENUE BUENA PARK, CALIFORNIA 90620



VIGGEN

All-balsa profile scale glider
is catapult launched.

Has a flashing climb and
gentle glide.

FRANK SCOTT



Viggen: The three-forked thunderbolt from the hammer of Thor. Viggen is also the amazing new fighter for the defense of Sweden.

Built by Svenska Aeroplan AB, better known to us as SAAB, the Viggen possesses Mach 2 performance yet will not rely on vulnerable airfields. It is as versatile as our own Phantom and will undertake attack, reconnaissance, and all weather intercept roles. All of this, yet it only needs a 1500-ft. runway, or highway, for its operations.

Our model has the flashing climb of the original, yet is quite easily built with little expense.

Construction

Begin by covering your work table with a piece of Saran Warp so the glue won't stick where it shouldn't; glue the 1/16" sheet balsa wing pieces together flat as there is no dihedral or curved airfoil. While the wing dries, cut out the fuselage from a firm piece of 1/8" balsa. Round the edges with sandpaper and glue the 1/16" sheet balsa fin and sub fin in place.

The wing should be dry now; sand it smooth and round the edges with fine sandpaper.

The canard stabilizer, or foreplane if you will, is cut from 1/16" sheet balsa and sanded. Cut it apart at the center and glue back together propping up each stabilizer tip 3/4" for the necessary dihedral.

You will find that it is much easier to decorate the model at this point than after it is assembled; therefore mark out all desired control surface outlines and

panel lines with fine pointed felt tipped marking pens or ballpoint pen. Well-stocked hobby shops may have Swedish decals, but if not, make your own insignia on plain white paper with colored ink or pen, then cut out and glue in place.

To assemble the model it is only necessary to slide the stabilizer and wing into their proper slots and glue very securely. Make sure the parts are carefully aligned before the glue dries.

Bend the launching hook from a paper clip, shove the end into the wood of the fuselage, and glue very securely to complete the model. It is important to locate the hook as shown on the plan.

Flying

Now that you're ready to fly the Viggen, check to see that your model balances at the location shown on the plan. No ballast has been necessary on our Viggens, but if yours does not balance correctly, add bits of clay to nose or tail as required.

Hand glide your model to check for proper flight, correct turning with bits of clay on the high wing and do not warp the surfaces for adjustments, as the higher speeds during launch can cause over control and subsequent surprises.

Prepare the hi-start launcher with a ten-ft. length of 1/8" flat rubber tied at one end to a stick driven into the ground and with a 30- or 40-ft. length of string at the other end. A paper clip may be tied at the remaining end of the string to complete the catapult.

Now it's launch time. Slip the paper clip over the hook in the model and draw the rubber taut. Face the Viggen into the wind and if you grasp the model by the upper rear corner of the fin it will automatically come to the proper angle for a smooth, high launch.

If the model tries to loop as it comes off the towing line, simply add more string to the towline until the model comes off in a flat glide. If the model stalls in the glide and flutters down without recovering, add a bit of weight, to the nose and possibly bend the trailing edge of the stabilizer down to prevent diving. Note that the action of the elevators on a canard model is opposite that of the conventional airplane.

Have fun with your Viggen, and with a bit of turn in the glide you should have no trouble flying in a field the size of the average school yard.

Material List

One 1/16 x 3 x 36" sheet balsa (flying surfaces); one 1/8 x 2 x 18" sheet balsa (fuselage); two paper clips; model cement; felt marking pens and decals as required; ten ft. 1/8" flat rubber and string for catapult.

TAPE "

STABILIZER REQUIRES 3/4"
DIHEDRAL UNDER EACH TIP

NOSE →

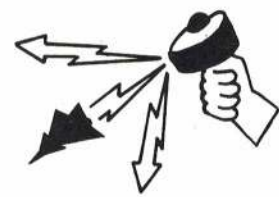

"VIGGEN"
FULL SIZE PLANS

HOLD MODEL HERE
FOR LAUNCHING

SAAB 37

-1

1/16" SHEET FIN

1/16" SHEET STABILIZER

FOR STABILIZER

C.G.



SLOT FOR WING

BLACK

GREY

YELLOW

PAPER CLIP WIRE
TOW HOOK

1/16" SHEET SUB FIN

DESIGNED & DRAWN BY FRANK SCOTT

SIG THE FINEST IN MODEL AIRPLANE KIT

FOR MORE R-C FUN BUILD SIG'S FOAM WING FLYERS

ALL USE SIG'S SEMI-SYMETRICAL MOLDED FOAM WING

AERO SPORTSTER



BEAVER

KIT RC-19 ENGINES: .15-.19
WT., NO RADIO 37 OZ.
STRIP AILERONS
SCALE APPEARANCE
MOLDED ENGINE COWLING
FORMED SPRING ALUM. LDG. GEAR

KIT RC-18 ENGINES: .09-.15
WT., NO RADIO, 32 OZ.
MOLDED ENGINE COWLING
FORMED LANDING GEAR
SPORT FLYER

REPLACEMENT WING - \$3.75



RELIC

RC KIT RC-17 ENGINES: .09-.15
WT., NO RADIO, 32 OZ.
FORMED LANDING GEAR
SPORT FLYER

\$1395

KIT RC-22 ENGINES: .09-.10-.15
WT., NO RADIO, 21 OZ.
MOLDED ENGINE COWLING
FORMED SPRING ALUM. LDG. GEAR



\$995 R-C SPORTSTER

MOLDED FOAM WING ONLY \$350

Maxey Hester's World-Famous

RYAN STA

KIT RC-27
\$5495

ENGINE .60
WINGSPAN 72"

AN EXACT SCALE MODEL OF JOHN GOSNEY'S AEROBATIC RYAN
WON 2nd IN R/C SCALE WORLD CHAMPIONSHIPS
A FABULOUS KIT OF A CLASSIC AIRPLANE

✓ CHECK THESE SPECIAL RYAN KIT FEATURES

- ✓ FORTY-THREE FORMED PLASTIC PARTS —
- ✓ TWO 13 1/2 x 18" 3-VIEW DRAWINGS —
- ✓ CONTROL-LINE CONVERSION DIRECTIONS —
- ✓ DIE-CUT FORMERS AND RIBS —
- ✓ SHARP, CLEAR, INSTRUMENT DIALS —
- ✓ BIG INSTRUCTION BOOK —
- ✓ PARTIALLY SHAPED FUSELAGE SIDES —
- ✓ SIG ALUMINUM MOTOR MOUNTS —
- ✓ FORMED LANDING GEAR —
- ✓ SPECIAL SCALE SPINNER AND BACKPLATE —
- ✓ EASY-TO-USE FLYING WIRE MATERIAL —
- ✓ AUTHENTIC, COLORFUL DECAL SHEET —
- ✓ NEW TYPE, REALISTIC APPEARING INSTRUMENT RINGS —
- ✓ THREE GIANT 37" x 49" CONSTRUCTION DRAWINGS —
- ✓ PLYWOOD, PLASTIC, HARDWOOD, HARDWARE, ETC. —
- ✓ QUALITY SIG Balsa FOR STRUCTURE AND PLANKING —
- ✓ SHAPED AND NOTCHED TRAILING EDGE, AILERON AND FLAP PARTS —

ZLIN AKROBAT

1969 NATIONALS WINNER!
4TH IN WORLD CHAMPIONSHIP



\$3995

ENGINES-.60
WINGSPAN 70"

KIT RC-23

The Zlin Akrobat is an outstanding scale model of one of the finest aerobatic airplanes ever produced. It won the full-scale aerobatic championships in 1967. Proportions of the airplane are such that it makes an ideal R-C model. Construction is standard built-up balsa fuselage and a foam wing sheeted with balsa. Maxey Hester, the designer, won the 1969 Nationals and placed fourth in the World Championships.

PROFILE SPAD-7

C/L WW-1 SLOW COMBAT



Designed by Kirk Kirkham

Shaped Balsa Fuselage
Die Cut Ribs & Tail
Formed, Notched LE, TE
Formed Landing Gear

Huge 3-Color Decals
Hardware & Hinges
Select SIG Balsa
Hardwood Engine Mounts

KIT CL-4
\$795

WINGSPAN 30 1/2"
ENGINES .19-.35

KIT FF-6
\$495



RAMROD 250

40 1/2" Wingspan
250 Sq. In. Area

Full-Size Detailed Plans
Die-Cut SIG Balsa
Die-Cut SIG Plywood
Covering Material

Claude McCullough's Famous

YAK 18P



KIT RC-16 FOR .60 ENGINE
WINGSPAN 72"

\$4995

Never before has an RC Scale Model been offered that has been so thoroughly researched and so accurately scaled down from the full-sized aircraft. The Yak 18 was chosen because the basic design of the airplane was capable of nearly all maneuvers and flies with the characteristics of the full scale airplane. Months of research went into the design before the prototype was built. The plans show a wealth of scale detail that will satisfy even the most demanding modeler. Ground handling is a cinch with the wide track tricycle gear.

C/L WW-1 SLOW COMBAT

PROFILE FOKKER D-7

KIT CL-5
\$795

WINGSPAN 33"
ENGINES .19-.35

Select SIG Balsa
Hardware & Hinges
Die Cut Ribs & Tail
Formed Landing Gear

Huge 3-Color Decals
Shaped Balsa Fuselage
Formed, Notched LE, TE
Hardwood Engine Mounts

Designed by Kirk Kirkham

THE FINEST IN SEMI-SCALE STUNT

P-40 WARHAWK



KIT CL-2
\$1195

A Realistic Model of a Famous Fighter
45" Wingspan
Formed Wire Parts
Hardware
Covering Material
Plastic Canopy

For .19 to .35
Molded Engine
Flying Tiger
Stunt Flaps
Die-Cut SIG Balsa

ITS

KIT RC -24
Ailerons
Engine Cowling
Kit Canopy
Landing Gear



\$1395
STITS FLUTTERBUG

KIT RC-21 WT., NO RADIO, 28 OZ.
SPORT SCALE ENGINES: .09-.15
STEERABLE NOSE GEAR
MOLDED ENGINE COWLING
FUEL-PROOF MOLDED BUTYRATE CANOPY



STINSON L-5

ENGINES: .09-.15
WT., NO RADIO, 28 OZ
VERY STABLE
\$995 KIT RC-20



BANSHEE



KIT CL-11

NATIONALS WINNER

\$995

5th Place 1971 Nationals Jr. Stunt
by Dan Osdoba

U/C PROFILE STUNTER WITH FLAPS

The BANSHEE was designed by Mike Stott to create a control line stunt model that would be easy to build, yet have flying qualities comparable to the best stunters. The BANSHEE has proven itself on both points. Very easy to build, it flies like the Nationals-winning Chipmunk. Docile enough for a beginner, yet the maneuverability to please the expert. A great addition to the Sig kit line.

SEMI-SCALE CHIPMUNK

\$1495

KIT CL-3

CONTROL LINE STUNTER

FOR ENGINES .29 to 40
WINGSPAN 54"

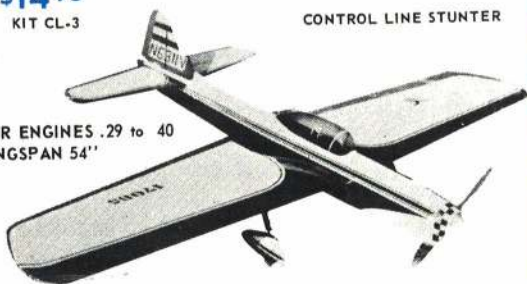

NATIONALS WINNER!

1st Place CL Precision Aerobatics in 1969 by Mike Stott
4th Place CL Precision Aerobatics in 1971 by Dave Osdoba

Fairchild PT-19

WINGSPAN 72"
FOR ENGINES .45 to .60



KIT RC-2

\$4195

FEATURED IN FULL COLOR ON THE
COVER OF MARCH, 1969 MODEL AIRPLANE NEWS

The SIG kit of the Fairchild PT-19 is one of the classic RC scale kits. Beautiful, realistic scale flight that is an unforgettable thrill to witness. Big 72" Wingspan. Will take engines .45 to .60. Kit features a one-piece molded engine cowling, five sheets of detailed plans and instructions, six sheets of authentic decals, and die-cut balsa and plywood. A model you will really be proud of.

Kirkham

AWK
LINER

us Fighter
.35 Engines
Engine Cowling
er Decals
Balsa

A BRAND NEW KIT
OF AN OLD FAVORITE

PIPER J-3 CUB

FEATURING A ONE-PIECE WING
UNIQUE WING MOUNTING FEATURE
Puts No Stress on Cabin Structure



KIT RC-3
\$2395

THE PERFECT TRAINER

VERY STABLE AND EASY TO FLY
A NOVICE CAN SAFELY FLY THE CUB

Shock-Mounted Wing Panels
Authentic Decals
Authentic Scale
Fully Detailed

Full-size Detailed Plans
Die-Cut SIG Balsa and Plywood
Molded Engine Cowling
Die-cut Windshield

The J-3 Cub has long been our best selling R-C kit. The re-designed kit makes it better than ever. A unique wing mounting does not depend on the cabin structure for strength. In spite of the fact it is an accurate scale model, it is so stable that it makes an ideal trainer. Simple structure makes an easy-building model.

AN AUTHENTIC R-C SCALE MODEL
of Hazel Sig's
CLIPPED WING CUB



WINGSPAN 56"
LENGTH 42"
FOR ENGINES .19 to .35

KIT RC-26
\$2395

Standard Balsa Construction
Strong One-Piece Wing
Molded Engine Cowling
Authentic Decals
Formed Landing Gear
Full-Size Detailed Plans
Aluminum Engine Mounts
Die-Cut SIG Balsa and Plywood

The full-scale airplane is a Reed Clipped Wing Conversion, built up from a 1941 Piper J-3 Cub for Hazel Sigafosse, co-owner of Sig Mfg. Co. The airframe was completely rebuilt and 3 1/2 feet removed from each wing panel. With a 75 hp. engine, the result is a highly aerobatic airplane that is really a joy to fly. With its blue and white sunburst paint job it is a great crowd pleaser.

A Beautiful Model of a Truly Outstanding Airplane



Send \$1.00 Today for
SIG'S BIG NEW CATALOG!
The Modeler's Wishbook™

NO POSTAGE REQUIRED WHEN ORDERING CATALOG ALONE

THE FALL AND WINTER SIG CATALOG is the greatest Model Airplane Catalog yet! Over 244 pages, with sixteen pages in full color, devoted exclusively to merchandise used in the building or flying of model airplanes. Features the complete Sig Line, plus practically all other lines available. Hundreds of models are illustrated, including gliders, sailplanes, rubber-powered flying scale, control line stunt and scale, and every type of R-C model. Send \$1.00 today for your copy or buy it from your local hobby dealer. You will agree that it is the best bargain in the model airplane industry.

SEE YOUR DEALER FIRST! If he will not supply you, then order directly from our plant. We will ship promptly. To Order, please add \$1.00 for postage and handling in the U. S. Canadian orders please add \$1.50. Minimum order is \$1.00. Please remit by bank draft, check or money order. Print your name and address plainly. Sorry, No C.O.D. shipments. All prices subject to change without notice.

ORDERING INSTRUCTIONS

SIG MANUFACTURING CO., INC
401 S. FRONT STREET
MONTEZUMA, IOWA 50171

LEADING EDGES MAY BE REINFORCED WITH "SCOTCH"

1/16" SHEET WING, MAKE FROM FOUR PIECES, GRAIN AS SHOWN.

POSITION OF UNDERWING INSIGNIA

SLOT

1/8" SHEET FUSELAGE

COLOR & TRIM WITH FELT TIP PENS, DO NOT DOPE MODEL.

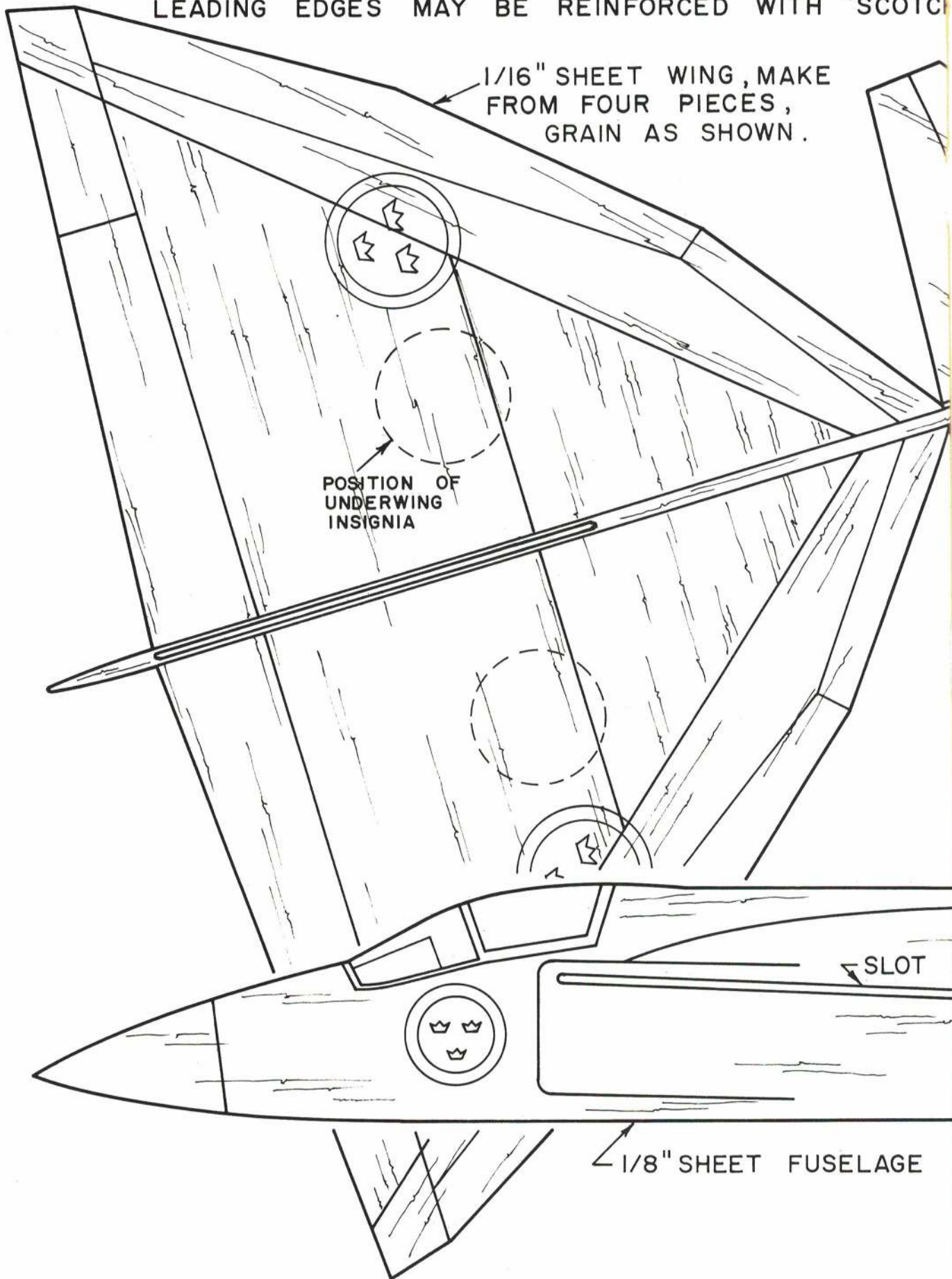

Graupner

the brandname
for top quality!

R/C SAILPLANE MODELS

DANDY

Ind. No. 4227

Wingspan 63"
ideal model for intro-
duction, convertible
to powered glider

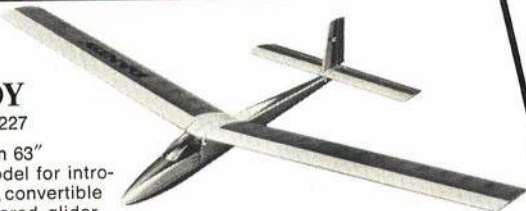

AMIGO II

Ind. No. 4219

Wingspan 78 3/4"
for simple aerobatics,
convertible to powered
glider

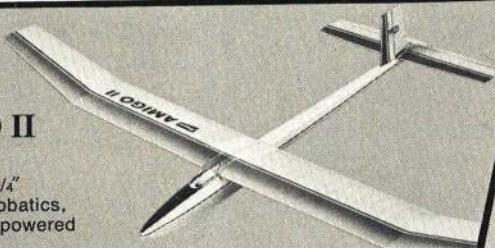

CUMULUS 2800

Ind. No. 4235

Wingspan 110 1/4"
A-R-F-soarer with swept
surfaces, convertible
to powered glider

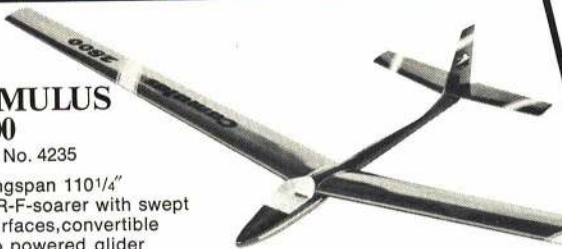

CIRRUS

Ind. No. 4229

Wingspan 118 1/8"
successful as the
original, ready-
formed fuselage components,
convertible to powered glider

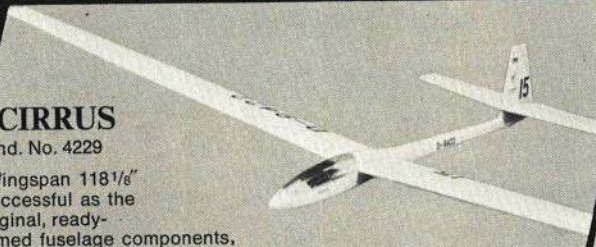

AS K 14

Ind. No. 4237

Wingspan 90 1/2"
ready-formed,
powered glider for aerobatics,
for engines of up to .15 cu. in.



R/C POWER MODELS

TERRY

Ind. No. 4635

Wingspan 41 3/8"
handy introduction
model, for engines
of .09 cu. in.



TAXI

Ind. No. 4625

Wingspan 59 1/16"
R/C trainer for engines
of .15-.35 cu. in.



MIDDLE STICK

Ind. No. 4631

Wingspan 55 1/8"
aerobatic model
designed by former
World-Champion
Phil Kraft, U.S.A.
for engines of
.40 cu. in. and the NSU/Wankel model airplane engine

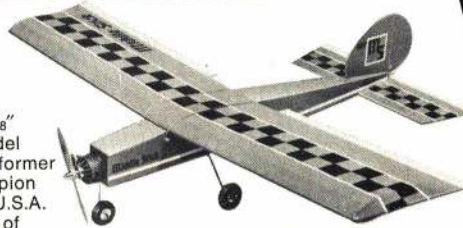

KWIK FLY MK 3

Ind. No. 4629

Wingspan 59 1/2"
low wing designed
by former World-
Champion Phil Kraft, U.S.A.
for engines of .60 cu. in.

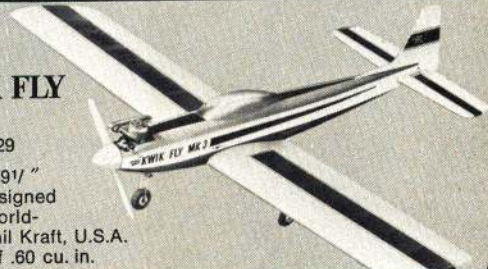

CESSNA 177 cardinal

Ind. No. 4633

Wingspan 61"
for engines of
appr. .30 cu. in.
semi-scale after
the new CESSNA type, ready-formed components



AHM, Associated Hobby Mfrs.,
Inc.
621 East Cayuga Street
Philadelphia / PA 19120

French Motor Co. Inc.
33, Berry Street
San Francisco / Calif. 94107

Midwest Model Supply Co.
6929 West 59th Street
Chicago / Illinois 60638

Royal Products Corp.
6190 E. Evans Avenue
Denver / Colorado 80222

getting started in R/C

JIM McNERNEY

Should I Build or Buy a Radio

In earlier articles we discussed "build or buy" philosophies for airplanes and some of the considerations in deciding what kind of a radio is right for you. Now you're faced with another choice, namely, should you buy a ready-made radio or build one from one of the many kits available? Again, this is a very personal decision. It is hoped that this discussion will give you some ideas to help make up your mind.

If you have no interest in electronics, are in a hurry to fly and have the money, the choice is obvious. If you've built an electronic kit or two you may consider tackling an RC system. If you've never built an electronic kit of any kind, or if the last thing you fooled with was a Williamson tube type amplifier or a five tube superhet, it would behoove you to build one of the new, sub-miniature transistorized kits such as the Heathkit Thumb Tach or a transistorized Volt-ohm meter. If you have any serious problems with these projects, you shouldn't attempt an RC kit.

Once you decide to build your RC system, you must then decide on which one. As far as the type system: Pulse proportional or digital proportional, number and type of servos and transmitter layout, read our earlier article on choosing a radio. Kits differ in such things as parts quality, detail and clarity of instructions, ease of construction and, to some extent performance of the finished product, availability of service; construction advice is also a consideration for the novice kit builder. Most kit manufacturers will provide a copy of the assembly instruction along with the specifications of the finished product, all for a few dollars.

A study of these manuals can tell lots about kit quality and construction difficulty. Some manufacturers stipulate that their kits are not designed for novices. Some point out the need for special test equipment not normally available to the novice. If the instruc-

tions appear to be unclear or ambiguous, the kit is not for you. Some of the manufacturers' kits are available locally, either at a hobby shop or at manufacturer's franchised stores. You can look at the parts, instructions and, sometimes, the finished product.

You will need certain tools to construct a kit. We'll talk about some of the basic ones. The soldering iron can cause the most difficulty. A 25 watt iron with a 1/16" chisel or conical tip is recommended. Hotter irons will lift the lands off the board and damage components. Smaller ones can cause cold solder joints or make desoldering very difficult. Three other major items are small needle-nose pliers, small diagonal cutters and wire strippers. In addition, you'll need various sizes of standard and Phillips head screw drivers and a set of small sockets or nut drivers. Another really handy gadget is a three- to five-power magnifier. In fact, my favorite is an articulated magnifier with a fluorescent lamp built into it.

You will find, when working on printed circuit boards, that some operations require three or more hands. I have solved this problem by mounting a fly-tying vise on my workbench. The jaws are adjustable and hold all thicknesses of board. This frees both hands to hold the solder and iron, etc. You can make your own board holder using clothespins or alligator clips. In order to keep your iron clean, keep a damp sponge handy. Periodically wipe the tip of the iron through the sponge. You'll also need some kind of solvent to remove the flux from a completed circuit board. Dope thinner can be used, but be careful not to get any on the component side as it will remove the coding stripes from resistors, etc. You can also use alcohol or trichlorethane.

Good construction practice also dictates use of a spray coating on finished circuit boards. You can also use a clear polyurethane or acrylic. Don't put it on too thick and under no circumstances should you "pot" the boards. In our next article we'll discuss more building hints and use of test equipment.

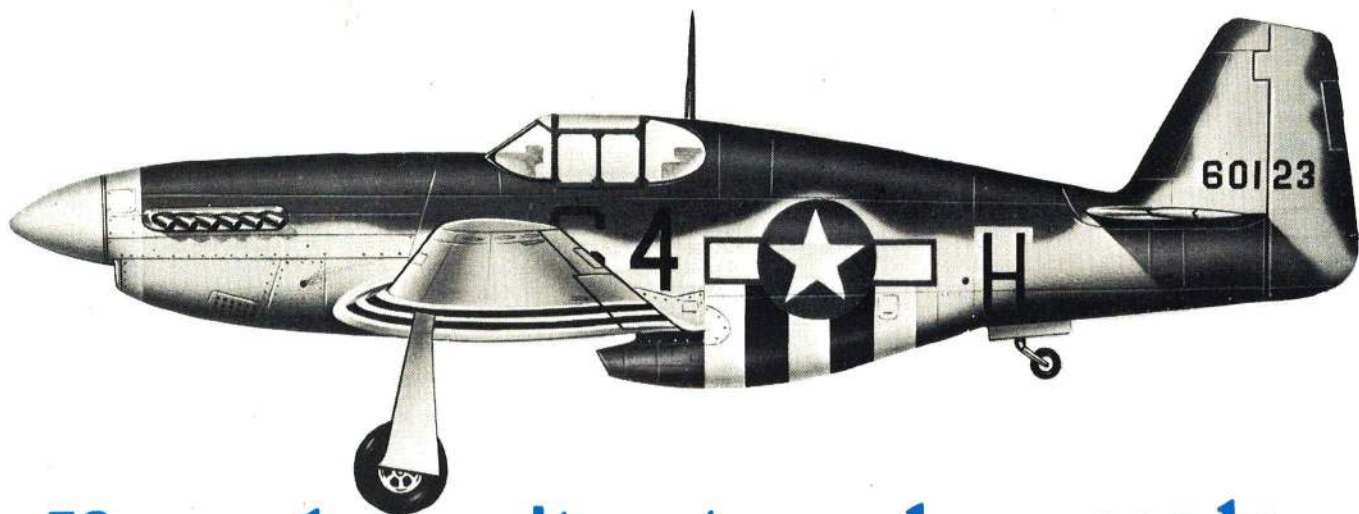

If you haven't yet made a scale model, there's no excuse—Now!

Our new Radio Controlled P-51 Mustang is a *Standoff Scale* model. You can build it in about the same time a Kwik-Fli takes, but when you're through, you've got a model that only a ruler can tell from a true scale plane.

This means that in the same building time of your next sport or pattern R'C, you could have instead *this Mustang* . . . an authentic looking plane that flies like a sport model — no tricky handling.

Designed by Scale Champ Dave Platt, wing span is 60" for .40 to .60 engines and full house R'C. The flaps can be stationary or operable. And like all Top Flite kits, it has exciting new features and time saving ideas.

Take a step UP—to a real-looking airplane!

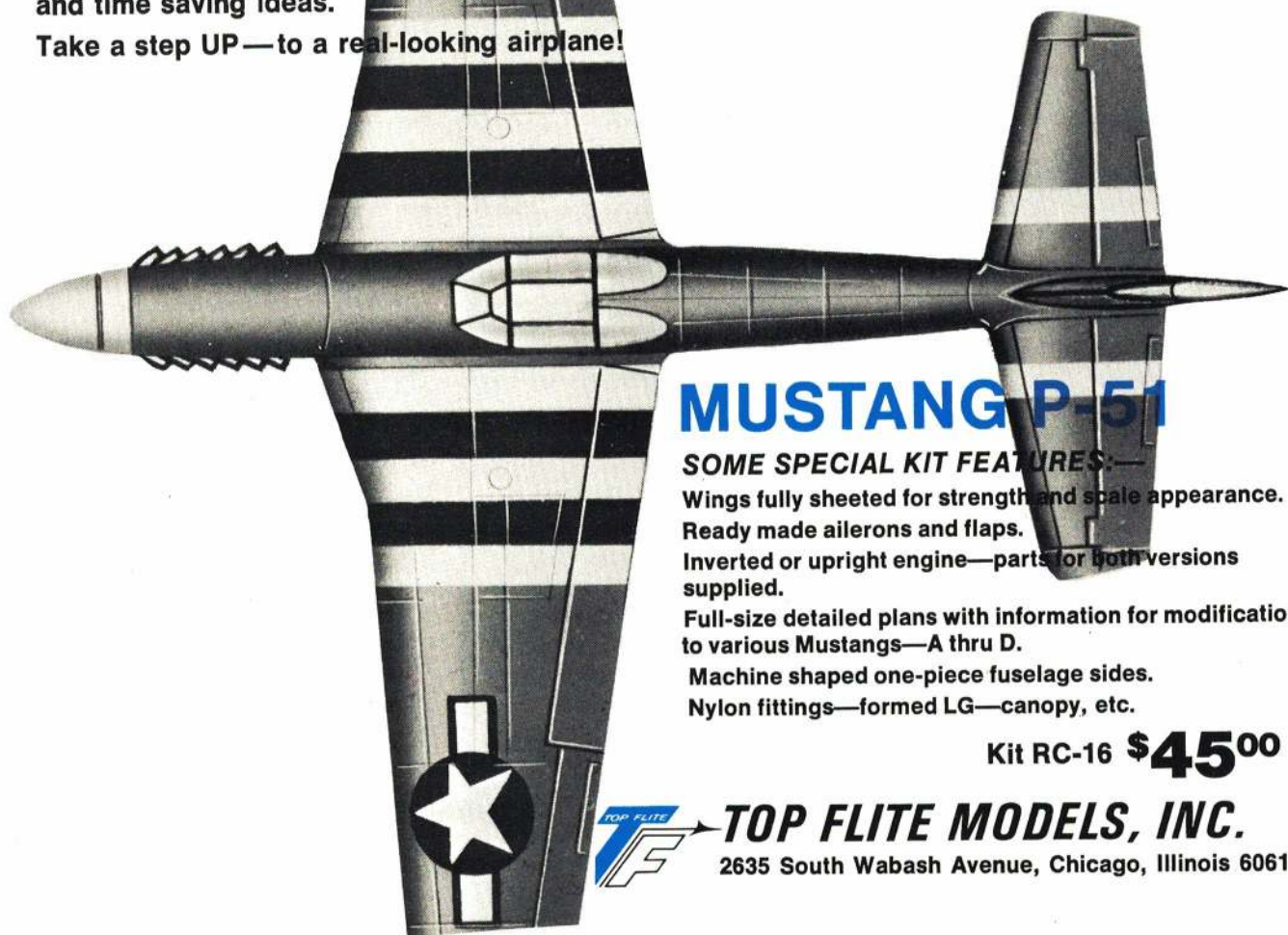

MUSTANG P-51

SOME SPECIAL KIT FEATURES:—

Wings fully sheeted for strength and scale appearance.

Ready made ailerons and flaps.

Inverted or upright engine—parts for both versions supplied.

Full-size detailed plans with information for modification to various Mustangs—A thru D.

Machine shaped one-piece fuselage sides.

Nylon fittings—formed LG—canopy, etc.

Kit RC-16 **\$45⁰⁰**



TOP FLITE MODELS, INC.

2635 South Wabash Avenue, Chicago, Illinois 60616

CLAUDE McCULLOUGH ON RC

Zeroing In: It appears that 1972 Nats Scale winner Bud Nosen is not going to rest on his laurels or his Skyraider and is hard at work on a new airplane for '73, a super-detailed edition of the classic World War II Japanese standard fighter. To retract the long slim legs of the undercarriage a home-built unit is being installed, actuated by Sonic Systems air drive servos, two on each gear for positive action. With a good collection of data and photos he

CONSTRUCTION IDEA BY BUD NOSEN

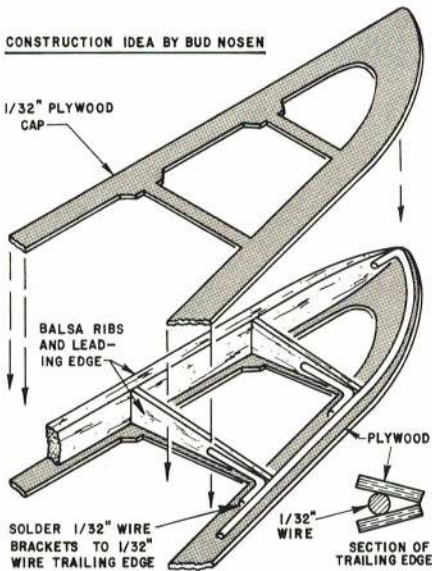

is bearing down on getting every part reproduced exactly. The accompanying drawing shows the ingenious construction used to duplicate the metal frame, fabric covered ailerons, elevators and rudder of the prototype. Bud says it is not heavy and can be sanded down to quite a thin edge that is strong enough not to warp. He suggests 1/32" plywood but perhaps 1/64" wing skin plywood would also work for this application and be even lighter.

Since the '73 Nats RC Scale event will also serve as the selection trials for the three-member U.S. team to the 1974 Scale World Championships, it seems likely that the Zero will be a model to watch.



First place in RC Scale at the Miniature Air-Expo in Minneapolis went to Chuck Nelson's impressive Jenny. Wingspan: 98 1/4". Enya 60. This model had 227 flights!

Bigger Better?: The Coffee Airfoilers Newsletter has a discussion on whether Sport Scale should continue with a limitation in engine size to below .61 cu. in. The Perrine, Florida Aero Modelers have proposed to Lee Webster, their district Scale Contest Board member, that the top displacement be raised to 1.25, the same as for the regular AMA Scale event. Coincidentally there are reports from AMA sources that it may be possible soon to have full insurance coverage for engines of over .61 in. Scale. Up to now they are only covered at sanctioned contests. There have been few if any safety problems connected with large engines in Scale models and, in fact, a good case can be made for ample power being of positive value. Webster has asked for comments from his district. Since the matter will undoubtedly come to a vote before the SCB soon, anyone with a pro or con opinion

should contact his Scale CB representative. Check the AMA section for addresses.

BILL BOSS ON CL

Improved Bellcrank: One of the most important features in the building of a scale plane is hidden from the view of spectators and judges. That item is the control system—the item that permits us to operate the elevator, and perhaps throttle control, flaps, dropping of bombs, auxiliary tanks and the many other operating features you may have seen from time to time.

The heart of the control system as you know is the bellcrank, and if it does not operate properly we could have disastrous results. Bellcrank installations in which no features other than elevator control are employed present little if any trouble to the modeler. Even the commonly used Roberts system presents very few problems if installed carefully, and used in light to medium weight planes (0-6 lbs.). However, when the weight gets beyond the 6-7 lb. range I have observed problems such as the system sticking in the high-speed position, and even the bending of the mounting plate in models ten lb. and over. I have even had reports of the long arms of the elevator bellcrank folding back. These troubles are generally caused by a tilting of the bellcrank,

which is a result of the pull generated by the weight and speed of the plane. A solution to the problem is to support the bellcrank to prevent the tilting action while the maximum pull is on the system. Illustrated in the accompanying sketch and photos is a modification to the standard Roberts unit that I have devised, and have found to work very satisfactorily. The modified unit requires considerably more space in the model and is therefore designed for use in large models.

The first step in building the new unit is to disassemble a Roberts three-line bellcrank, but before disassembly study carefully how the parts are placed and how the unit works. Attention now will aid you in the reassembly later on. Disassembly is accomplished by filing off the peened ends of the bellcrank center pin and third line swivel arm retainer at one end of the mounting plate. The third line crank and swivel arm should not be taken apart—see exploded view photo of parts. Retain parts marked "R" for building the new unit.

New parts required to make up the modified unit are shown in the sketch and are designated A through G. Also required (but not shown) is a duplicate of the bottom mounting plate. The duplicate plate can be made of aluminum or steel of the same thickness as the original. I chose to use a plate from a second

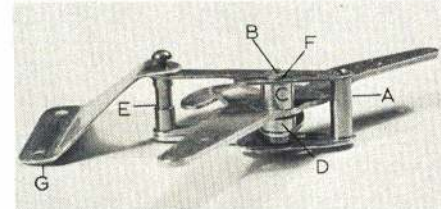

Completed modified unit provides smoother operation by eliminating the tilting action of the bellcrank in high-speed position. Bellcrank shown here is an upside down unit to be used upright in a Mosquito Bomber being built by the author.

Roberts unit that was no longer serviceable.

The measurements shown on the sketch for the new parts should be self-explanatory, and it should be evident that some sort of metal turning equipment is required to make them, therefore I will not go into machining procedures. The only dimensions missing from the sketch are the size of the holes through Parts A and E and the size of Bracket G. The holes in Parts A and E are 4/40 bolt clearance holes for mounting purposes. No dimensions are shown on Bracket G as it should be made in accordance with the space available in the wing or fuselage of the plane in which it is to be mounted. Note: Parts A, B and E are made from mild steel rod; Parts C, D and F are made of brass and G is made of 1/16" sheet aluminum.

A study of how the original unit was taken apart, and the photos showing the completed modified unit should illustrate how the new unit is assembled. However the following points might be worth noting: Part E is recessed to provide clearance for the elevator bellcrank in the low-speed position. Part D is force fitted over B at the .130 dia. point. Part C should turn freely when placed over B and through the elevator bellcrank. Parts F are force fitted on the ends of B, and B is then peened for final retention of F parts.

Top and bottom plates are secured to Parts A and F by using a wide center punch that is entered in one end of these parts while the other end is set with a second punch. Hold first punch securely in a vise. Repeat procedure for top and bottom of both pins until both plates are secure. During assembly a small amount of plate lubricant can be applied to the moving parts.

When the unit is finished and properly mounted with Bracket G, the new bellcrank should provide smoother operation and eliminate the problems discussed earlier. Tilting of the center pin is prevented by the support provided by the top and bottom plates of the unit. Bracket G bears the force that is placed on the upper plate by pin B when the unit is in the high-speed position and when pull testing is being done.

If anyone has questions about the unit or would like a large copy of the sketch send a self-addressed stamped envelope to Bill Boss, c/o AAM.

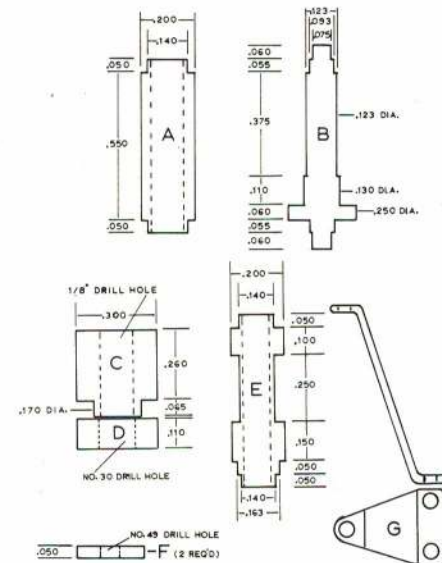

New parts required to modify standard Roberts bellcrank for extra heavy duty in large scale models.

Exploded view of modified unit shows relative position of parts and general order of assembly.

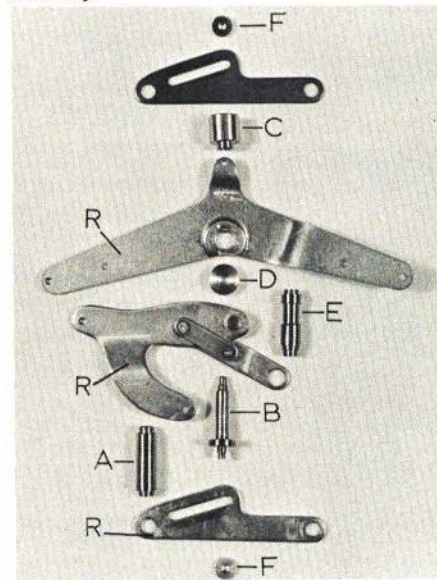

Nat's Scale Winner: Robert Talchik (Chicago, Ill.), a participant in the Scale event for the past few years, earned a second-place slot in Open Class with his well-executed original Miles Magister. Bob's plane was powered with a throttle controlled O.S. 50 swinging an 11-6 prop. The plane was finished with Sig and Aerogloss products to produce a flat, weathered look that was seen on quite a few planes this year.



Dave Platt (L) assists Bob Talchik, both of the Chicago Scalemasters, with a last minute engine run-up prior to flight of Bob's Miles Magister at 72 Nats. Bob placed second in the Open Scale Class.

WALT MOONEY ON FF

Electric Power: There is a new motor on the market that has an opportunity to make a large contribution to FF Scale although it is advertised as an RC motor. Note the word motor, rather than engine because this is the Astro Flight electric motor. The power output of the Astro 10 is truly impressive. It will turn a 7-4 prop about 12,000 rpm on 12 volts and runs about five min. on a charge of the NiCad battery pack that is supplied with the motor. Although the complete setup is heavier than a glow plug power plant setup

ASTRO-FLIGHT MOTOR DIMENSIONS

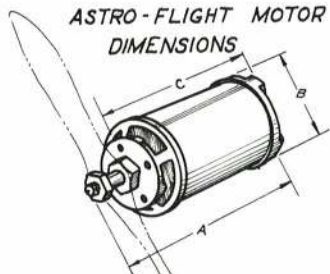

ASTRO FLIGHT	A	B	C	PROP.
10	3 1/2"	1 5/8"	2 1/2"	7-4, 8-3 1/2
25	4 1/2"	2"	2 3/4"	8-6, 9-7, 10-5

for FF Scale, its instant starting, low noise output, and relief from the need for fuel-proofing really make it a desirable power plant.

Although the five-min. duration is desirable for RC, the FF Scale builder can remove a couple of cells from the battery pack and rearrange for a shorter run with less all up weight. It is also possible to tailor the voltage and get the exact power setting for that scale-type flight.

There are control line possibilities also. It's easy to visualize a belt-carried battery pack with a reostat built into the UC handle, giving a really simple and effective throttle control.

No matter where the Astro Flight motor is used, it will certainly result in less starting frustration and more approval from the noise sensitive neighbors.

Flightmasters Contest: Having written about electric-powered models, it is time to report that there was an electric-powered event at the last Flightmasters Scale contest. Most of the models were powered with motors removed from the Mattel ready-to-fly. Tony Nacarada won the event with an Aeronca C-3 which on its best flight flew out of sight in five min.

The most impressive model was Joe Tsirgi's Dufaux scout, a French WW I fighter

(Continued on page 99)

STAHLWERK MARK IIIb BY WALT MOONEY
USES HUNGERFORD WHEELS

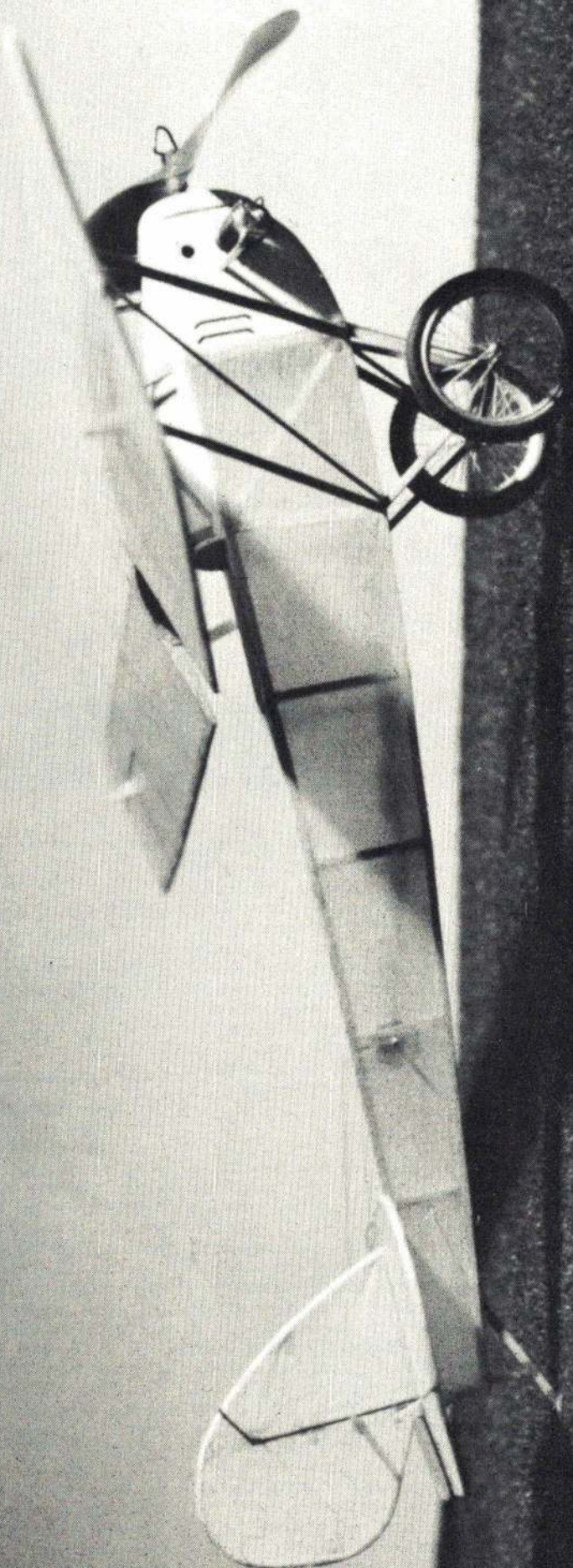



CURTISS ROBIN

The Curtiss Robin was the first closed cabin, three-piece airplane to appear on the market within the moderate price range. It was developed early in 1928 and sold for less than \$4000. The first models that appeared featured the famous Curtiss OX-5 engine; for construction simplicity, this is the plane we are presenting. Later design improvements included the Curtiss Challenger six cylinder radial air-cooled engine. The square fuselage makes it a snap to build and its generous wing area makes it a fine flyer.

Construction

Cover the plans with waxed paper and pin 3/32 square medium hard balsa stringers to the plan for the fuselage sides. Build one side directly over the other so they will be identical; when the glue is dry, lift them from the plan and gently slice them apart using a single-edge razor blade. Cut the rear motor supports from 1/16" plywood, drill a 1/8" hole in each and then glue them into place. Cut the top and bottom spacers from the same stock used on the fuselage sides. Now glue the fuselage halves together at the tail and then glue in the spacers starting at the rear and working toward the nose. Work very carefully here to make sure the fuselage cross section will be square. Bend the main landing gear strut from 1/16" piano wire and the tail skid from 1/32" piano wire. Fasten them into place as shown on the plan. Use thread wrapping

Have you made a
stick-and-tissue model recently?
Here's a simple scale
rubber job of a great old plane
from the golden age of aviation.

TED DAIGLE

and then apply glue liberally. Glue the balsa shock onto the tail skid. Finish the main landing gear after the wing and the wing struts have been assembled. Cut eight triangles from 3/32" balsa and notch them for 3/32" stringers. Glue these to the top edge of the fuselage nose section and glue in the stringers to simulate the engine cowling. Now glue the windshield supports and the landing gear strut supports in place. These parts are 3/32" stringers and balsa scrap.

Cut 16 wing ribs from 1/16" balsa and two from 1/8" balsa. Cut the wingtips from 1/8" soft balsa and pin them to the wing plan. Pin down the leading edge (1/8" square hard balsa), the wing spar (1/4 x 3/32" hard balsa), and the trailing edge (1/4 x 3/32" hard balsa). Fit the wing ribs and spar supports into place and glue the whole works. When the glue is dry, remove the wing from the workbench and gently taper the trailing edge and round the leading edge and the wingtips. Score the leading and

trailing edges and the spar just outside the two 1/8" center ribs and prop the wingtips up 1-1/8" from the table. Glue the cracked joints liberally and let them dry. Now build the skylight into the top of the wing center section.

Tail surface construction is straightforward. Simply pin 1/16 x 1/8" balsa to the plan and use 1/16" sheet for the curved sections of the tips.

Carve the nose block from a piece of soft balsa. The nose plug is carved from pine. After it has been drilled out, use epoxy glue to fasten small brass washers to the front and the back to serve as bearings. A plastic propeller can be used, but patterns for a balsa prop are on the plans.

Before covering, very gently sand all the framework and round off the edges of the tail surfaces. Use Jap tissue to cover the model. I used blue for the fuselage and yellow for the wings and tail surfaces. Outline the surface to be covered with clear dope; then lay a piece of tissue onto the surface and gently work out any wrinkles. Spray the covered surfaces with water and let them dry to shrink, then steam out any warps. Make up a mixture of 50% clear dope and 50% thinner and about ten drops of glycerin. This will give you a sealer for your model that is light, but yet will not shrink on the airframe and pull it out of shape. Give the model one coat of this mixture. Use thinned colored dope for the cockpit window frames. Glue on lightweight cellophane

CURTISS ROBIN OX-5

DESIGNED, DRAWN & BUILT BY
TED DAIGLE
INKED BY FRANK ELMIGER

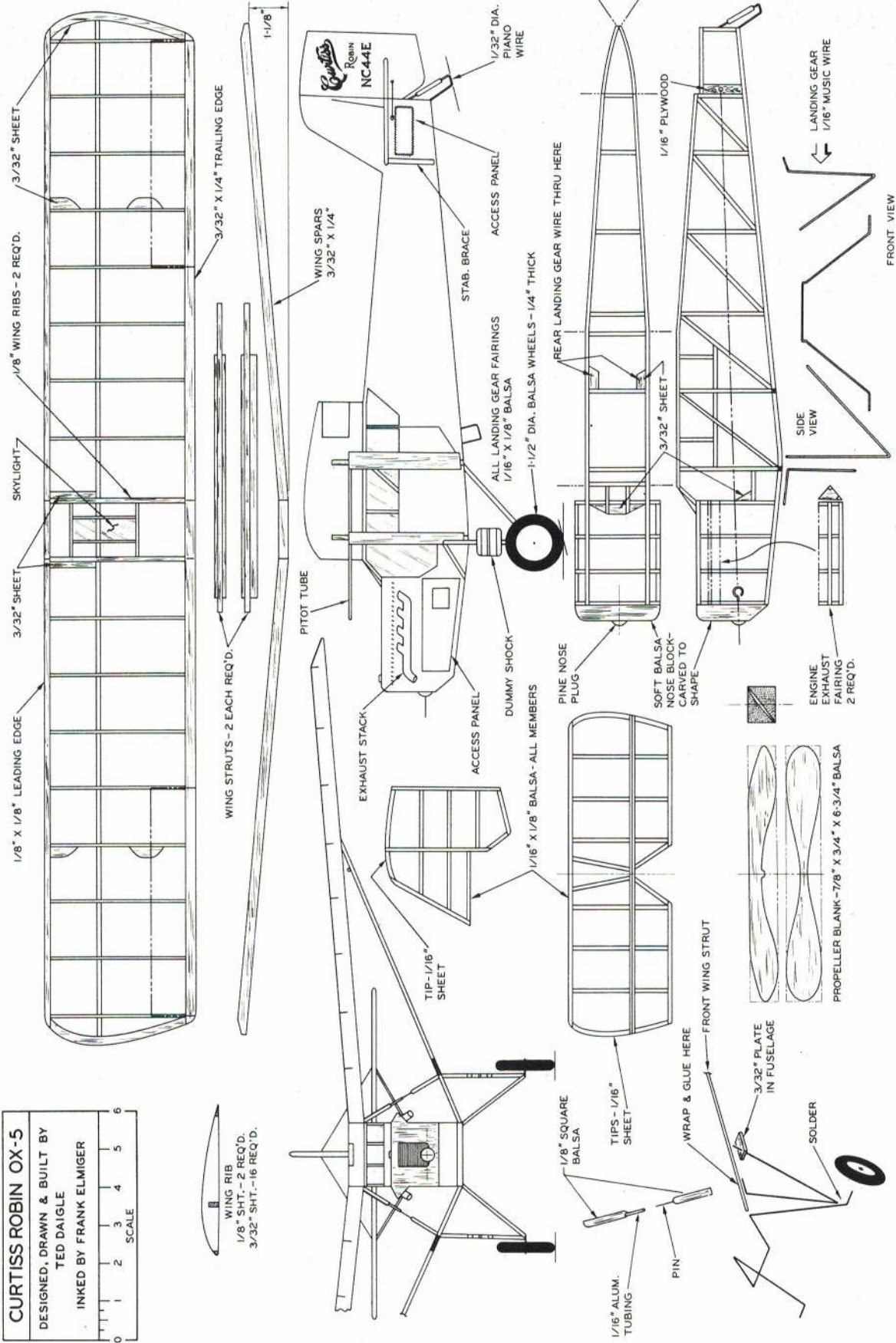

FULL SIZE PLANS AVAILABLE - SEE PAGE 84



Being a slow flyer with a large wing, the model will take off from close-mown grass.



The Robin has many square corners and straight lines. It was a durable workhorse in real life but not very fast.

for the windows and the skylight in the top of the wing.

You can now begin to assemble your model. Glue the wing into place and carefully check to make sure it is properly aligned. Spot glue the fin to the top of the elevator and hold the assembly in place on the elevator platform with rubber bands until the final flight adjustments are made.

Build four wing struts as shown on the plan and dope them silver and then glue them into place. When the glue has dried, complete the landing gear. Drill a small hole in each secondary landing gear strut support in the bottom of the fuselage. Bend two secondary landing gear struts from 1/32" piano wire and slip the rear of each into the holes you have drilled in the bottom of the fuselage. Wrap them with thread where they connect to the wing strut and glue thoroughly. Now solder these struts to the main landing gear struts where the two meet just above the axles. Glue soft balsa stringers to each strut wire and then add the two additional struts from the wing strut to the forward part of the fuselage. If you want to get fancy, install a shock strut from the top of the wing strut to the underside of the wing next to the top of the cabin window. This strut takes a lot of stress during landings. Cut two pieces of 1/16" OD aluminum tubing 3/4" long. Then take two straight pins and four pieces of soft balsa stringer 1/8 x 1/8" that are 3/4" long. Force a straight pin into the end of two of the pieces of balsa and clip off the heads of the pins. Very carefully force the aluminum tubing into the ends of the other two pieces of balsa. Now sand the balsa round, insert the pins into the tubing sections, and glue the ends of the struts into place and you have two neat-looking shock struts. The easy way is to cut two pieces of 1/16" rubber 1/8" short and hold them in place with pins while the glue dries.

Carve the engine exhaust stacks and the wheels from soft balsa. Paint the exhaust stacks silver, the wheels flat black and the hubs silver or yellow. The control surfaces can be outlined with black thread. Cut the thread to the proper length and dip it into clear dope. Then wipe off the excess dope, lay it into place and tap it lightly with your finger. The lettering and name on the fin can be applied with a fine point black felt pen.

The model should balance at the wing spar. Use a little bit of clay or some pieces of lead in the bottom of the nose block to make the adjustment. Now adjust your ship for a long, smooth glide by using small balsa wedges under the elevator assembly. If the model dives, raise the front edge of the elevator. If it stalls, raise the rear edge of the elevator. When you find you have it properly adjusted, glue the assembly in place and remove the rubber band. Now warp the rudder a little to adjust for a wide left-hand turn and install four strands of 1/4" flat rubber; try several hand-wound flights over tall grass to make sure the plane is properly trimmed under power. Now hook up your winder and pack in the turns. Good luck!

OL' BUZZARD

HAS

IT

ALL...

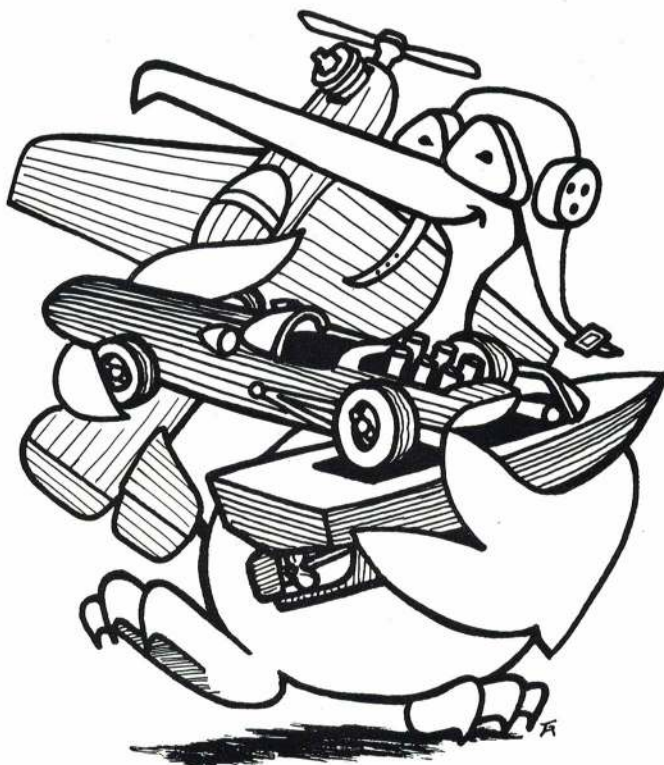

and we do too!

• planes • products

• boats • cars

just a few reasons

why you must

subscribe.

AMERICAN AIRCRAFT MODELER
733 FIFTEENTH STREET, NORTHWEST WASHINGTON, D.C. 20005
SPECIAL INTRODUCTORY OFFER TO NEW SUBSCRIBERS ONLY
 ONE YEAR (12 ISSUES) @ \$7.50
 PAYMENT ENCLOSED BILL ME
NAME _____
ADDRESS _____
CITY _____
STATE _____
ZIP _____

FOREIGN ORDERS MUST BE ACCOMPANIED BY AN ADDITIONAL \$2.00.

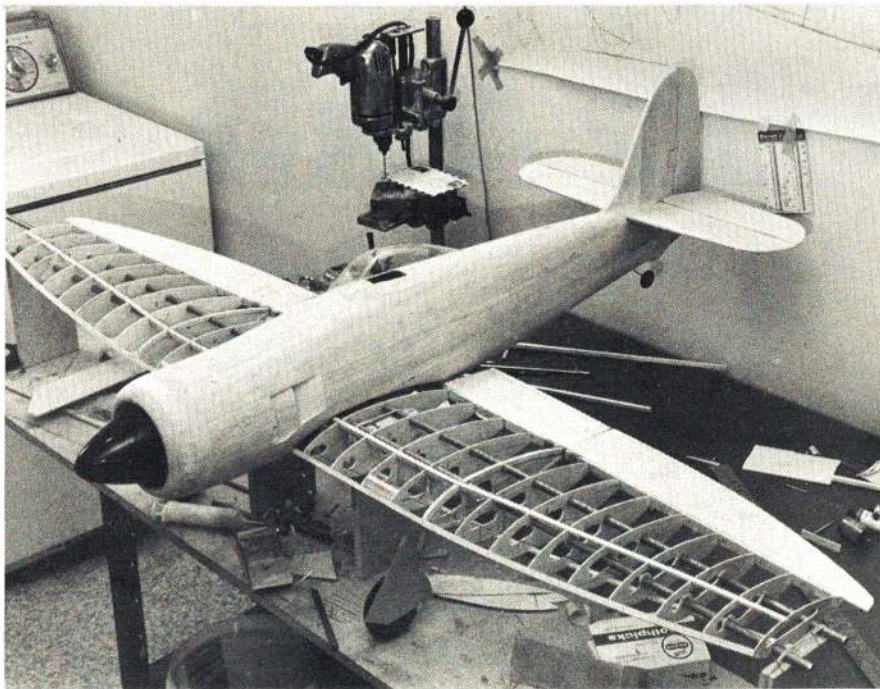

Fuselage after being bolted on. Alignment must be perfect by this stage. Note wing is jugged on rigid tubes, removed later.

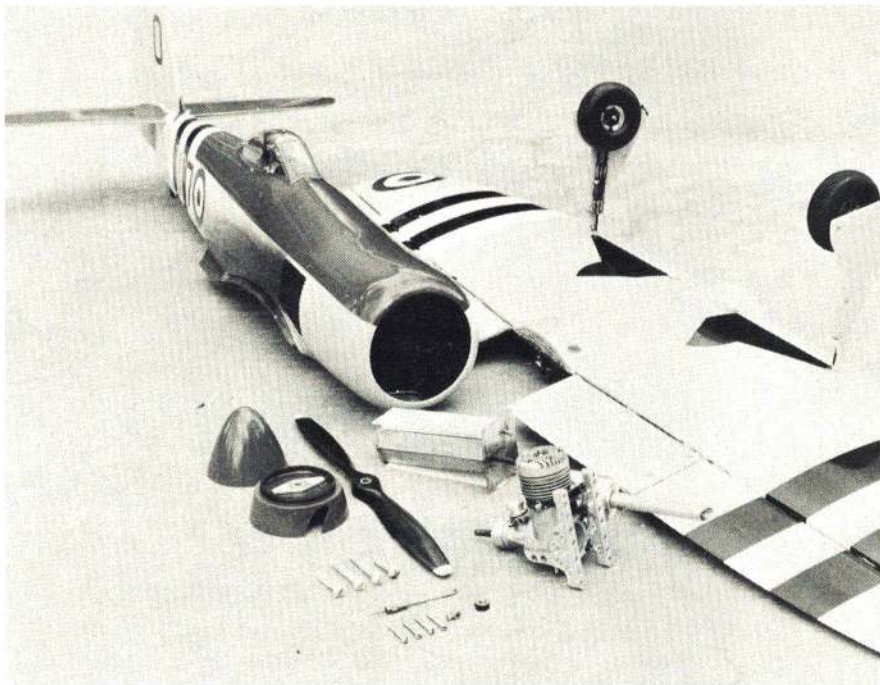

Tank is shimmed up or down by sheet balsa for engine run adjustment. This picture illustrates ease of repair and adjustment of major components and breakdown for shipping.

GO FOR BROKE

(Continued from page 32)

this at model size I built a 25% test section and found that it did indeed produce substantially more lift. Using this big improvement in lifting capability, I designed the Mustunts I and II for the novice stunt fliers to help them lick problems with weight. (Fig. 7)

Now I was ready to design the Sea Fury wing. I knew that to carry the Sea Fury's weight I was going to have to use large flaps and a 25% section. Take your choice, the wing would have to be either big or thick. Wait a minute! The AMA stunt pattern itself is asymmetrical requiring far more lift for the lower right triangle and hourglass corners than anywhere else in the pattern. Since these are both inside corners I should be able to get away with an asymmetrical airfoil with a 25% curvature on the top of the wing and a flatter 20 to 22% curvature on the bottom for the less demanding outside squares. By tailoring the airfoil to the lift requirements of the pattern, I could have my high lift characteristics and still slightly reduce the bulk of the wing. Again, I decided to "go for broke" and use the completely untried asymmetric airfoil concept on my Sea Fury to improve the appearance of the wing. At this point I built two new asymmetric test sections and waited six weeks for a calm wind night to test them (I live in Texas, you know). Finally, in desperation, I ran the tests in an eight-knot wind—I just had to get started building the Sea Fury wing.

While tests under windy conditions must be inaccurate, I still felt they would be useful indicators of relative performance. Sure enough, the airfoils tended to group on the graphs into families related by thickness. The 25% sections all performed 35 to 40% better than the best of the 18 to 20% Nobler and Bearcat airfoils. Clearly, thickness is far more important to airfoil lifting capability than any other characteristic such as profile or leading edge radius. (Figs. 7 & 8)

To explain my asymmetrical airfoil designations, the Sea Fury 25-20 has a top of the airfoil similar to the top half of a 25% symmetrical section. The bottom half of the Sea Fury 25-20 is similar to the bottom half of a 20% symmetrical airfoil.

The Sea Fury 25-20 test section lifted better inverted than the inverted Sea Fury 25-22 which was contrary to what I expected but probably accounted for by the 25-20's blunter leading edge radius. (Fig. 8) Had I conducted these tests in a calm wind, I would probably have used the 25-20 on my Sea Fury. As it happened, however, the airfoils with slightly sharper leading edges tended to run more smoothly, buffeting less in the wind, making it possible to gather sufficiently good plotting data with fewer automobile runs in each direction. This characteristic of smooth operation in the wind was, I thought, more important than the slight loss of lift inverted, so I selected the 25-22 and

(Continued on page 86)

FIRST PRIZE



GOES TO THE EGGSHELL

MOTHER NATURE DID A TOP-NOTCH JOB WHEN SHE CREATED THE EGGSHELL.

IT'S WATERPROOF. COMPLETELY SEALED. LIGHTWEIGHT, BUT STRONG. SMOOTH AND UNIFORM. IT'S MOLDED TO CONFORM PERFECTLY TO WHAT IT COVERS. IT WON'T PEEL OR FADE. AND IT PROTECTS THE EGG FROM HEAT AND COLD.

BUT, WHEN IT COMES TO COVERING A MODEL AIRPLANE, MONOKOTE IS ALL THESE THINGS, TOO. IN FACT, THERE ARE EVEN SOME THINGS MONOKOTE HAS OVER THE GOOD OL' EGGSHELL.

FIRST OF ALL, YOU CAN COVER YOUR MODEL WITH MONOKOTE IN A LOT LESS TIME THAN IT TAKES A HEN TO MAKE A SHELL.

AND YOU WOULDN'T THINK OF REPAIRING AN EGGSHELL ONCE IT CRACKS. BUT, WHEN YOU HAVE A LITTLE CRACK-UP WITH YOUR PLANE, YOU CAN REPAIR MONOKOTE INSTANTLY AND ALMOST INVISIBLY.

THEN, OF COURSE, AN EGG ONLY COMES IN TWO COLORS (EXCEPT AT EASTER). BUT, MONOKOTE COMES IN 18 COLORS, INCLUDING METALLICS AND PAINTABLE CLEAR.

SO, WHEN YOU THINK ABOUT IT, BEING THE WORLD'S SECOND GREATEST COVERING ISN'T BAD . . . BECAUSE, IN THE MODELING FIELD, WE'RE NUMBER 1.



TOP FLITE MODELS, INC.
2635 S. WABASH AVE.
CHICAGO, ILL. 60616

CONFIDENCE

Orbit flyers have it.

Here are two good reasons

1. Exclusive Orbit Solid Open Gimbal

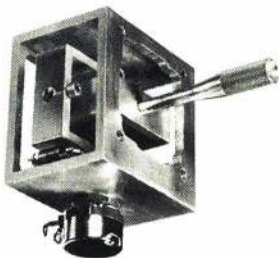

ABSOLUTELY RIGID
ASSEMBLY

UNMATCHED
PRECISION

Fork, cage, and frame are precision machined from aluminum extrusions. No bent metal, no plastic, no forced fit. Every muscle twitch becomes a command.

2. Exclusive Orbit All Metal Bearing Closed Gimbal

METAL TO METAL
SMOOTHNESS



NO DRAG
OR SLOP

Hardened steel ball in a low carbon steel race with a tolerance of less than 1/1000 of an inch gives you precision unmatched in any other closed gimbal.

One look tells you why they're better.
One flight tells you how much better they are.

ASK YOUR ORBIT DEALER
about Orbit for 1973
about Orbit's new warranty

First in R/C Technology since 1954.



Orbit Electronics
1641 Kaiser Ave.,
Santa Ana, Ca. 92705

In Canada: CRC Electronics,
60 Nugget Ave., Agincourt, Ont.

MACCHI C. 202

(Continued from page 24)

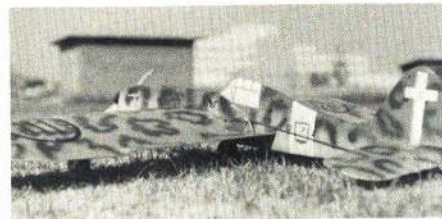

You can easily use an RC-type nylon control horn on the flaps and elevator. Use an adjustable clevis for flight trimming at the elevator.

Then epoxy the bellcrank platform in place.

Taking the wing of the building board, plank the top and bottom at the center section. Cut out the slots in the appropriate ribs for the hardwood landing gear mounts, and install the landing gear mounts. (Most hobby shops have these pre-cut for RC.) Install the 1/4 x 1/4" landing gear mount braces. These are essential, otherwise, the landing gear platform may go "crunch" through the wing upon landing.

Cut out and glue on the wing tips and wing tip braces. Install the 1/8" brass tubing leadout guides.

Cut out the 1/8" "C" differential and fixed flaps. Sand the wing and flaps, and glue on the fixed outboard flaps. Hinge and install the differential flaps, and epoxy on the 3/32" wire connector.

Bolt the flaphorn onto the flap, and bend the pushrod to length and install it in the horn. Solder a washer over the end.

Cut the fin, rudder, stabilizer, and elevators out of 1/8" "C". Glue the rudder to the fin with 1/4" rudder offset. Sand the surfaces; epoxy the 3/32" wire connectors to the elevators; hinge and install the elevators to the stabilizer.

Epoxy the wing into its slot in the fuselage. Use a square to make certain the alignment is correct, both horizontally and vertically. When the wing joint epoxy has cured, epoxy the stabilizer in its slot, and epoxy the filler piece on top of it. Then epoxy on the fin. Glue strips of nylon along all joints (I used Carl Goldberg Nylon Reinforcing Tape). This not only produces a good-looking fillet, but improves the strength of the joints.

Brush two coats of wood filler on the plane, except for the wings, and sand them smooth. Put a coat of clear dope on the wing, and sand off the fuzz. Paper the wing with medium weight Silkspan, doing the wing tips separately.

Now give the entire plane four coats of clear dope, sanding lightly after the first two. Paint the plane in the colors you desire. The original was finished in light and dark greys, with black and white trim.

Epoxy in the tail-wheel skid, and attach the 3/4" tail-wheel. Bend the 1/8" landing gear, and install the landing gear mounts with screws and

K&S FOR TUBING AND TOOLS!

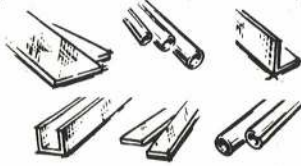
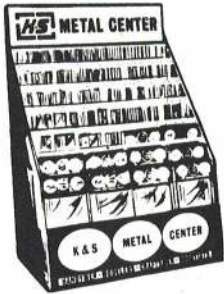

OUR CAREFULLY ENGINEERED LINE OF METAL PRODUCTS HAS UNLIMITED USES IN THE DEVELOPMENT OF ALL TYPES OF PROJECTS. ALL OF YOUR METAL NEEDS AVAILABLE IN ONE PLACE.

THERE IS NO SUBSTITUTE FOR QUALITY!



MODEL BUILDERS KIT

Packaged set of many different sizes and shapes of K & S Brass Tubes. This assortment's a necessity in every work shop.
Stock # 320 \$2.95 Set

TUBING BENDER KIT



This Kit will solve your Tube Bending Problems. Bends 1/16, 3/32, 1/8, 5/32, 3/16 Tubing
Stock # 321 \$.98 Set

ALUMINUM TUBE (12")

STOCK NO.	SIZE	PRICE EACH
100	1/16	.20
101	3/32	.25
102	1/8	.25
103	5/32	.25
104	3/16	.25
105	7/32	.30
106	1/4	.30
107	9/32	.35

SOFT BRASS FUEL TUBING (12")

STOCK NO.	SIZE	PRICE EACH
121	1/8 x 12	.30

BRASS STRIPS (12")

230	.016 x 1/4	.15
231	.016 x 1/2	.20
232	.016 x 1	.30
233	.016 x 3/4	.25
234	.016 x 2	.60
235	.025 x 1/4	.20
236	.025 x 1/2	.25
237	.025 x 1	.50
238	.025 x 3/4	.35
239	.025 x 2	.85
240	.032 x 1/4	.20
241	.032 x 1/2	.30
242	.032 x 1	.60
243	.032 x 3/4	.40
244	.032 x 2	1.10
245	.064 x 1/4	.38
246	.064 x 1/2	.75
247	.064 x 3/4	1.00
248	.064 x 1	1.50

BRASS ANGLE (12")

171	1/8 x 1/8	.30
172	5/32 x 5/32	.30
173	3/16 x 3/16	.35

BRASS CHANNEL (12")

181	1/8	.35
182	5/32	.35
183	3/16	.40

SOLID BRASS ROD (12")

160	1/32	.05
161	3/64	.10
162	1/16	.10
163	3/32	.15

ROUND PLATED SPRING WIRE (12")

STOCK NO.	SIZE	PRICE EACH
192	.032	.05
195	.047	.05
197	.055	.05
199	.063	.05

BRASS STREAMLINE TUBE (12")

122	9/64 x 5/16	.75
-----	-------------	-----

ROUND BRASS TUBE (12")

125	1/16	.15
126	3/32	.20
127	1/8	.20
128	5/32	.25
129	3/16	.25
130	7/32	.30
131	1/4	.30
132	9/32	.35
133	5/16	.40
134	11/32	.40
135	3/8	.40
136	13/32	.50
137	7/16	.55
138	15/32	.60
139	1/2	.65
140	17/32	.70
141	9/16	.80
142	19/32	.95
143	5/8	.95

SQUARE BRASS TUBE (12")

150	3/32 Sq.	.30
151	1/8 Sq.	.35
152	5/32 Sq.	.40
153	3/16 Sq.	.45
154	7/32 Sq.	.50
155	1/4 Sq.	.55

SHEET METAL (4" x 10")

250	.005 Brass	.50
251	.010 Brass	.70
252	.015 Brass	.90
253	.032 Brass	1.75
254	.008 Tin	.45
255	.016 Alu.	.40
256	.032 Alu.	.65
257	.064 Alu.	.90
258	Asst. Brass	.75
259	.025 Copper	1.75

COPPER TUBE (12")

120	1/8	.30
-----	-----	-----

SOLDERING GUN

Terrific Value Combined with the Latest Features - Instant Heat - 110 Volt - 100 Watt - Two Tips included.
#M 1200 \$7.95

EXTRA TIPS for Gun.

#M 1201 (Small) 6/Pkg. \$3.00

#M 1202 (Large) 6/Pkg. \$3.00



TOP QUALITY DRILL PRESSES

EXCLUSIVELY ENGINEERED BY K & S FOR DEMANDING CRAFTSMEN. THE BEST VALUE IN DRILL PRESSES ANYWHERE! COMPLETE WITH JACOBS TYPE CHUCK AND KEY.

Bench Model
78 Pounds and 28 Inches Tall
Motor Included
9" Swing
3 Speed
1/4" Drill Capacity

STOCK NO. 430 \$139.50



IF NOT AVAILABLE AT DEALER ORDER DIRECT

SOLDERING IRONS

NEW 12 VOLT
30 WATT
FIELD IRON

PLUGS INTO CAR LIGHTER FOR QUICK FIELD USE!
• MODEL 212 \$2.95

115 VOLT IRONS

• #M 300 - 30 Watt - Lightweight. \$2.95
• #M 900 - 60 Watt - High Capacity \$4.95

ASSORTED TIPS for M300 IRON

#284 (4 per pkg.) \$1.98 / Pkg.

ASSORTED TIPS for M900 IRON

#904 (3 per pkg.) \$1.98 / Pkg.



SANDPAPER



Assortment of all popular grits (25¢ per pkg.)

Stock #450 \$6.00 per Box
24 pkg. per box

SILKSPAN

The popular Economy covering

HEAVY	MEDIUM	LIGHT
SGM	GM	OO
#402	#401	#400
15 / Box	20 / Box	30 / Box

\$3.00 / Box



ACETATE SHEETS

Handy 8" x 10" Sheets for Forming Canopies, Windows, Windshields, etc.

Stock #301 \$1.00 ea. \$1.20/Pkg.

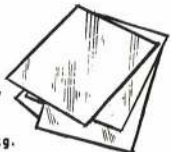

CONTROLLER PLUGS

Top quality controller plugs for the particular Hobbyist. (6 per card \$.69 ea.)

Stock #312 \$4.14 card



AEROSILK

100% pure Silk (HEAVY DUTY). The finest silk available.

#600 White #603 Green
#601 Orange #604 Yellow
#602 Blue #605 Red

1 Square Yard \$2.50



TOOL SETS

Sets of K & S top quality tools with individual handles. Ideal for home, workshop, and field use.

Set of 5 Nut Drivers #422 \$3.95

Set of 5 Open-End Wrenches #423 \$3.95

Set of 5 Phillips-Allen #424 \$3.95

Set of 6 Screwdrivers #426 \$3.50



KWIK-CHANGE TOOL SETS

Handy package of four different types of tools. These sets are the right size for the Hobbyist. Perfect for the R/C Flight Box.

#421 Tap Set \$5.95

#425 Screwdriver Set \$2.50

#427 Nut Driver Set \$3.25

#428 Open End Wrench Set \$3.25

#429 Phillips-Allen Set \$3.25



K&S ENGINEERING

6917 West 59th Street, Chicago, Illinois 60638

SEND 25¢ FOR CATALOG

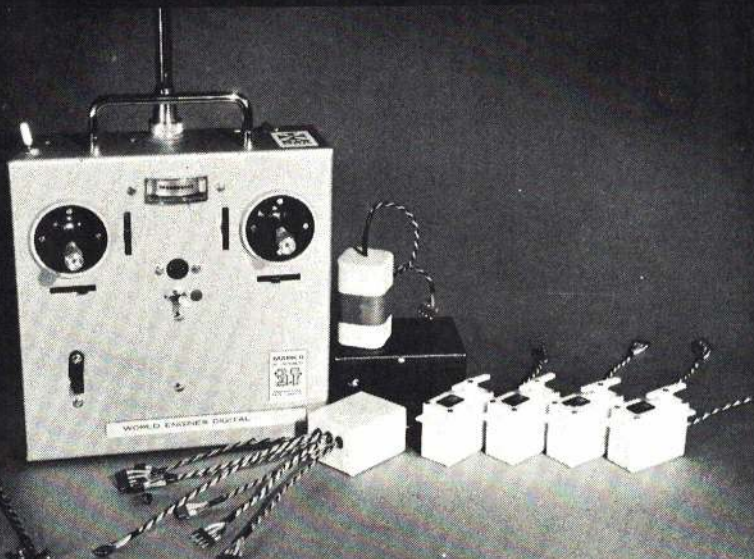

WORLD ENGINES DIGITAL EXPERT SERIES • BLUE MAX • DIGIT MIGIT

We have some great news this month in that our Dave Brown placed first in Class C Expert using a World Engines Expert Series Dual Stick system at the Winter Nationals in Tucson, Arizona. The contest was concluded on November 26th. This contest was sponsored by Don Dewey's Radio Control Modeler magazine. A heavy contingent from Louisiana and Texas came into this contest in addition to the heavy participation by California flyers. Dave also reports that even though Terry Prather did not win with his ABC Tigre 40, he was conceded by many to have the fastest plane in pylon (1:25.9). Dave powered his pattern winning model with a Supertigre G.60.

Our purpose in publishing these advertisements is to acquaint you with the things we are doing to World Engines Digital Systems. We are trying to tell you why we think our systems are better than anyone else's. Like every R/C equipment manufacturer, we are constantly working on improvements on our system and we are happy to report some of them to you at this time.

We recently started out our Expert Series with Allen Bradley's potentiometers. These are the major pots in the stick assembly. We noticed in trying to reduce our servo resolution to zero that when it was checked out with the transmitter in the system there was some dead band, so we went to work to try to find out just where this dead band was. We knew that it could not be in our integrated circuits which we have bragged about in the past at every opportunity. We found that these Allen Bradley pots which, incidentally, are used by some of our competitors, have some backlash. This backlash is testified to right on the potentiometer spec sheet as being plus or minus 1.5°—that is 3° all together. So, how do we get around this problem? We solved the

problem by using the same pot element that we use in our servo and making a special housing to carry the pot element brush on into the stick assembly. It works great!

Next, we would like to talk about our receiver. The receiver has to be the most sophisticated part of anybody's digital system. Our procedure in receiver development has been to explore new avenues of receiver improvement in the lab and then to go out and fly until the improvement is proven. Early this fall, we built a large model which could carry a tape recorder—a Norelco 88. We put some receivers in the test model that we had known to glitch thereby watching a model and watching a stop watch, we marked the times when the glitches appeared. Back in the lab we were able to correlate the visual glitches with the tape impressions and the results were very enlightening to say the least. This testing approach led to some very simple but effective changes in our receiver.



Dave Brown keeps pounding away at pattern contests and you will note from his record that he is getting better.

We also have other models here which are made so the receivers can be plugged in and out rapidly and these are used for testing runs of production receivers from time to time. Using this system in a couple of hours of solid flying it is possible to test up to 40 different receivers. This is the way Dave Brown gets in many hours of his practice flying. So, we claim that our receiver is not only a thoroughly tested device but it is also still simple enough that it can be included in a semi-kit and tuned up by a home builder.

Compare our system. A 12 volt power supply in the transmitter, very low battery drain through the servo amplifiers. Our system was the first to use an isolation transformer in the charger—regardless of what Don Dewey says. Well, it looks like we ran out of space without getting to say what we had on our mind. So, check in on our ad next month and we will pick up where we left off. Hope to see you at Toledo.

'72 RECORD

Nov. Tucson, Ariz. (R.C.M. contest)	1st
Aug. Lancaster, O.	2nd
Aug. Canton, Ohio	1st
July Nats, Glenview	14th
July St. Louisville (Columbus, O.)	1st
July Charleston, W. Va.	1st
June Dayton, O.	3rd
June Chicago, Ill.	3rd
June Nashville, Tenn.	
May Chardon, O.	3rd
May Chicago, Ill.	4th
May Huntsville	6th
Jan. Tangerine	7th

washers, as shown in the photograph. Put on the two-in wheels, and solder washers over the ends.

Drill the holes for the bolts and install your engine. Solder lugs onto the gas tank (Perfect No. 10), and bolt them on, making certain the feed line is in line with the center.

Cut and crimp the leadouts; put on the fuel line, and it's ready for its maiden flight.

Flying

Begin flying the plane on .015 52-ft. lines. When you become accustomed to the Macchi's characteristics, try flying it on .012 60-ft. lines. We fly the stunt pattern on the 60s, but usually fly combat on the 52s for the extra "feel" of the plane.

I am always happy to hear what other modelers think of my designs. If you have any questions or comments, send them to me at 4337 Miranda, Palo Alto, Calif. 94306.

Once again, do not be afraid to change the outlines to those of a plane that you like. This is the best way that I know to get started designing your own. Have fun!

SSP 5

(Continued from page 44)

slightly, slowing it down. The original position requires more nose weight because it is always in the main rotor downwash, but the model will not pitch with sudden power changes. A slightly forward ($\frac{1}{4}$ to $\frac{1}{2}$ ") CG position is more stable and should work out well.

The next revision is anyone's guess. Who knows what we will be flying in 1973? As for me, I am starting a new model—scale this time.

Questions

Bearings: The most frequently asked question is, "Where can the tail rotor gyro bearing be purchased?" Well fellows, I goofed. I had the wrong Part No. The correct No. is SR 1028, thanks to Syd Horne of Ontario who is building an SSP. The bearing can also be purchased from PIC Design Corp., P.O. Box 335, Benrus Center, Ridgefield, Conn. 06877 (Part No. E 5-3 at \$10.60). The main swashplate bearing should not be difficult to obtain. Bearings, Inc. will handle it for about \$3.00.

-33: Another question asked is, "Where is Part -33?" Somehow it was omitted from the reduced plans in the magazine, but it is on the full-size drawings.

Tail Rotor Gyro: I wish I had a dollar for each time I have been asked how the tail rotor gyro works. The following is a brief explanation.

The gyro, located just behind the tail rotor blades, is a rotating mass. When the model yaws, the gyro wants to remain in its former plane. Notice from the illustrations that the gyro has the same heading (Figures A through C). If a horizontal pivot is installed on the gyro, the gyro is then forced to change its heading following the model (Figures D through F). When the gyro is forced to follow the model with a horizontal



WORLD ENGINES

8960 ROSSASH AVE.

CINCINNATI, OHIO 45236

pivot, the gyro will precess 90° later in the direction of the force (Figures G through I). If the horizontal pin is not on the centerline of rotation but above or below it, the gyro will also slide in or out when it precesses. The slider on which the gimbal and then the gyro is mounted is connected to the pitch arms of the tail rotor blades by means of pitch links. When the gyro precesses, the slider moves and changes the tail rotor blades collective pitch (Figures J through L).

Tail rotor collective control from the servo is achieved by pushing or pulling the gyro with a light spring. The gyro can override the spring, therefore the servo travel at the tail rotor must be about twice the normal input. The gyro would almost cancel a normal collective input. The springs also provide a centering for the gyro. The tail of the model will wag if the gyro is not sufficiently damped. STP on the tail rotor shaft best accomplishes this.

The kinematics and dynamics of a tail rotor gyro are fairly sensitive. The only change from the drawings so far is to locate the tail rotor on the left side, change the pitch arms to 3/4", and add an extra 1/32" thick ring to the gyro. These changes allow better maneuverability especially for stall turns. (Figure J and drawings). Do not make kinematic or dynamic changes other than the ones mentioned above until you are thoroughly familiar with its operation. The weight perpendicular to the blade cancels the blade's tendency to go to flat pitch; a light blade will require less weight, a heavier blade more. Adjust this weight by spinning the whole tail rotor assembly. When the weight is proper, the gyro will remain vertical and will not compress either spring. When adjusting the tail rotor collective to cancel main rotor torque, adjust the angle of the pitch arm relative to the tail rotor blade. This will allow the gyro to be vertical when proper tail rotor collective is reached. The gyro will not work properly if it is compressing one of the springs or if it is not vertical when operating at normal tail rotor collective.

Engine: About the biggest misconception is that a 60 engine will fly the SSP. Sure it will, but you will be replacing belts every other flight; a 45 has plenty of power. A 60 can be used if a 15-tooth and a 72-tooth pulley are incorporated for the second stage reduction. Also use a 11- or 12-tooth pulley on the engine. Check Stock Drive's catalog to determine belt sizes. A 60-sized SSP will then outfly anything, even some fixed wings, and will be easy to handle.

Clutch: When making the clutch, almost any thickness cork will do. Just machine it to size after bonding it to the clutch drum. Although neoprene cork is mentioned, plain cork will do. The spring clips on the clutch should pull the shoes together slightly. The tighter the shoes are pulled together, the higher the engagement rpm. Remember the clutch is doing 1000 rpm when the engine is doing 2800 rpm.

Springs-General: My springs are wound in a drill press or a lathe. The

NEW PILOT ARTF'S



This sharp looking aircraft is designed to fly on elevator, rudder, and motor. It is a relatively large 3 channel airplane, 52 1/2" span. The manufacturer recommends a 20 but would probably fly on a 35 O.K. Nice vacuum formed fuselage, balsa elevator, molded foam wing with solid dihedral brace. Model also includes steerable nosewheel. A little larger than the Pilot Cherokee and Olympia. Worth the additional \$5.00.



This model features the same type of vacuum formed fuselage and foam wing construction used in the popular Pilot Cavalier. The wing span 49.6". Length 39.37" (1 meter). Wing area 461 sq. in. Engine 4 cu. in. Weight approximately 5 lbs. This almost ready to fly pylon racer with racing lines, wheel pants, should make active pylon racing possible for the modeler too busy to build. This is particularly important in this rugged event.



The Phantom is an almost ready to fly U/Control model constructed of vacuum ABS plastic and wood. A very striking looking sidewinder. Wing span 25". Length 25". Wing area 192 Sq. in. Recommended engine 15 to 19. Flying weight approximately 1.35 lbs. Here is a chance for some U/Control flyers to enjoy the advantages of an A.R.F. package.



This is a U/Control combat trainer for a 20 engine. Wing span 30". It is a composite wood and vacuum formed aircraft. Even the name is a ringer.



This glider is the Pilot Thermal's little brother. Foam wings. Vacuum formed fuselage with a plywood pod. Manufacturer recommends an .06 engine. .049 engine would probably work well.

SERVICE EXPERTS

ARIZONA

R/C Engineering
P.O. Box 1451
Scottsdale, Ariz. 85252
Phone 602-949-5700

CALIFORNIA

Hobby Center
Electronics Dept., G. E. Lyman
861 Marsh St.
San Luis Obispo, Calif. 92107
Phone 805-543-3942
We sell and repair all types of major R/C Systems

COLORADO

Hood Electronics & Hobbies
5302 Howell St.
Arvada, Colorado 80002
Sales Installation
and repair of all makes of R/C Equipment
Phone 303-278-2079

FLORIDA

E. W. Bryant R/C
Box 415
Punta Gorda, Fla. 33950
We service all types of R/C gear—also build radio kits to your spec's.
Hobby Center
11600 N.W. 7th Ave.
Miami, Fla. 33168
Phone 305-681-4441
The Hobby House, Inc.
397 Perry, 17-52
Casselberry, Fla. 32707

GEORGIA

Hobby Distributors
4 Avondale Road
Avondale Estates, Ga. 30002

ILLINOIS

Stanton Hobby Shop
4734 Milwaukee
Chicago, Ill. 60630
Controltronics
Karr Mfg. Div.
Box 92
Thomassboro, Ill. 61878
Radio Control Central
Box 56122
Chicago, Ill. 60656
Chicago, Ill. 312-545-3815

MINNESOTA

Al Schwartz
2787 Fernwood
St. Paul, Minn. 55113
Exclusively World Engines

MISSOURI

C. W. Reed
5408 Woodson Road
Raytown, Mo. 64133
Contact Charley for quote on Blue Max Systems
Supertigre and OS
Max Engines

NEW HAMPSHIRE

Dambros Hobbies Inc.
58 Lake St.
Nashua, N.H. 03060
Low low prices on R/C equipment plus fast repair service

NEW JERSEY

J.A. Denke
355 Doremus Avenue
Glen Rock, N.J. 07452
For same day service ship entire system with fully charged batteries.
R/L Control Systems
P.O. Box 280
Denver, New Jersey 07834
Tel. 201-627-7070

NEW YORK

Jerry Behrens
619 Monroe Blvd.
Long Beach, N.Y. 11561
Phone: 516-432-1874

NORTH CAROLINA

Triangle Technical Products
600 Glenwood Ave.
Raleigh, North Carolina 27601
Phone 919-833-1131

OHIO

Country R/C
12450 Amity Rd.
Brookville, O. 45309
4 miles S. of Interstate 70
We repair most R/C equipment
Gerald L. Peters, prop.
Town & Country Hobbyland
55 Country Road
Columbus, O. 43213
Neal's Hobby & Sport Shop
4409 Mahoning Ave.
Warren, Ohio 44483

OKLAHOMA

Tulsa R/C
1241 S. 105 E. Ave.
Tulsa, Oklahoma 74128
Phone 836-5425
R/C Equipment Sales
FAST Service—
Mail or Direct

OREGON

Strictly R/C
7868 S. W. Capitol Hwy.
Portland, Oregon 97219

TEXAS

Wilson's Hobby Shop
2205 West Beauregard
San Angelo, Texas 76901
Custom built units by Eldon Wilson. All parts, stocked for MAH, Blue Max, Complete repair for all W.E. radios

VIRGINIA

Radio Electronic Model Shop
800 National Ave.
Winchester, Va. 22601
Phone 703-567-1730
Complete sales and service
Kits and equipment

OUR R/C LINE INCLUDES:



WORLD'S EXPERT'S SERIES 6ch \$460



MK II BLUE MAX SYSTEMS 6 ch \$340



NEW PYLON MIGIT 5 ch \$285

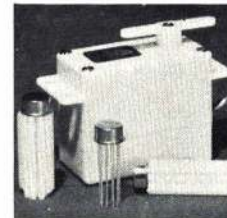

S-5 ASSEM 35.00
S-5 SEMI 24.98
RETRACT 40.00



CATALOG
Price - \$1.00



WORLD ENGINES

8960 ROSSASH AVE.

CINCINNATI, OHIO 45236

Northfield-Ross Engine Clinic

Phone 516-431-1112

If you have a question or a comment about the Northfield-Ross engines please call Lou Ross, collect.

The entire Northfield team works diligently to produce these engines with tender, loving care and loves to hear and read the raves our "baby" has been earning.

We are especially anxious to talk to anyone who has run into a problem or any of you who want some first hand answers before you buy.

The response to the Northfield-

Ross .60 Twin has been almost entirely positive so that we haven't been able to get much practical or useful consumer feedback.

Lou will answer any questions about your airplane and its suitability for our .60 Twin—or the 4 cylinder—or the 6 cylinder engines.

If you want a brochure write to Northfield Precision Instrument Corp., 4400 Austin Blvd., Island Park, L. I., New York 11558.



new! Superior, High Strength Structure Foam
Quick and Easy-to-Assemble

"FLYRO-FOAM"

Radio-Control

MODEL PLANE KITS

"FLYRO-FOAM" Model Airplane Kits are made of a new high strength structure foam, light in weight, but extremely rigid. Due to our unique molding method, both inside and outside skin is unusually firm. This rigidity, particularly in the fuselage,

permits harder than usual landings. "FLYRO-FOAM" models have attractive lines not generally seen or achieved in balsa kits. They are designed for sport or contest flying for novice or expert. Ease-of-Assembly gives you more time to fly.

- PRECISION MOLDED HIGH-EFFICIENT AIRFOIL
- ONE-PIECE MOLDED STABILIZER
- ONE-PIECE MOLDED VERTICAL FIN
- "ASSEMBLE-EASE" FUSELAGE SECTIONS
- SNAP-FIT PRE-CUT WOOD FUSELAGE COMPONENTS
- METAL ENGINE MOUNT, NUTS & BOLTS
- FORMED LANDING GEAR

THESE PLANES CAN BE FLOWN WITH "GALLOPING GOST", SINGLE AND ANY MULTI-CHANNEL RADIO-CONTROL EQUIPMENT



FRONTIER I \$19.95
Wing Span: 41.34" Engine: 09-.19



FRONTIER V \$32.50
Wing Span: 49.61" Engine: 19-36



WHISPER 60 \$75.00
Wing Span: 62.99" Engine: 50-60



TITAN 60 \$75.00
Wing Span: 62.99" Engine: 50-60



STAR FIRE \$31.50
Wing Span: 48.03" Engine: 19-25



BLUE FIRE \$24.50
Wing Span: 41.73" Engine: 09-19

SALES REPS WANTED. MANY TERRITORIES OPEN.

HOBBY CENTERS

76 March 1973

SOLD THRU FULL-FUNCTION HOBBY SHOPS. ASK YOUR HOBBY WHOLESALE FOR THE "FLYRO-FOAM" LINE. STANDARD DISCOUNTS APPLY.

size rod that the spring is to be wound around is chucked; about 1/4" of the end of the music wire is bent at 90°. A Du-Bro collar with a knotch on the inside diameter is fitted over the rod next to the chuck. The music wire is inserted through the notch and into the void between the chuck jaws. The collar is then tightened. On large wire, such as 1/16" music wire, a hole is drilled into the rod. Hold the end of the music wire with pliers and have someone turn on the machine—use low speed! Keep the wire taut and the coils next to each other by pulling the wire away from the spring generation. A tension spring with a preload is the result. Then make a compression spring, and pull the tension spring open. Put the spring back on the mandrel and compress until the coils bottom. This is not the way normal springs are wound but it is satisfactory for models.

S.D.P.: Stock Drive Products (55 S. Denton Ave., New Hyde Park, N.Y. 11040) is not making any of the special machined parts, therefore both the assembly and detail drawings are required. The kits include only stock parts. The kit for the SSP-5 is No. HK 103 and is priced at \$44.95, or, if you have previous parts package for SSP, order in addition 4 each 47Y 55 FSS 3718 bearing, 2 each IC4 Y3216 gears, 2 each IC4 Y2012 gears and 2 each 7B4 F006 bushing.

Construction

The hub drawing is an attempt to simplify a spring-loaded hub. The lack of collective adjustment also makes it more reliable and lighter. The 1/4" OD x 3/16 ID flap pivot rod is a drill rod, heat treated after final machining. The feather pivot rod is a drill rod, heat treated after final machining. The feather pivot trunnion should be a heat treatable steel such as 1/2" dia. 4340 or drill rod. Ream the hole for the flap pivot rod, .249 dia. There must be a good press fit of the flap pin inside the feathering pin to insure proper spring operation.

After final machining of the feathering pin, it should be heat treated so that it will not lose its close tolerance flap pinhole through several disassemblies. The No. 4-40 shoulder bolt is a special and can be made from a No. 6-32 socket head cap screw. The shoulder should be about 1/2" long. The rubber on the clevis is mainly a feathering stop.

The tail rotor gear box shown is very similar to John Burkam's in the August 1972 issue of AAM. The gear box is closed out in back which adds strength in holding the gears in mesh. Although a 1/8" dia. shaft is used because of the tail rotor gyro, as much as a 3/16" dia. tail rotor shaft could be used on a different control configuration. Lubricate with moly grease.

The installation of the tail rotor takeoff shown does not require a new belt/pulley height adjustment. The flat on the 3/16" dia. clutch shaft for the gear set screw provides the shoulder when the No. 10-32 stop nut is lightly torqued down. The 1/8" dia. music wire comes undersized and oversized at the hobby shops. Take your micrometer

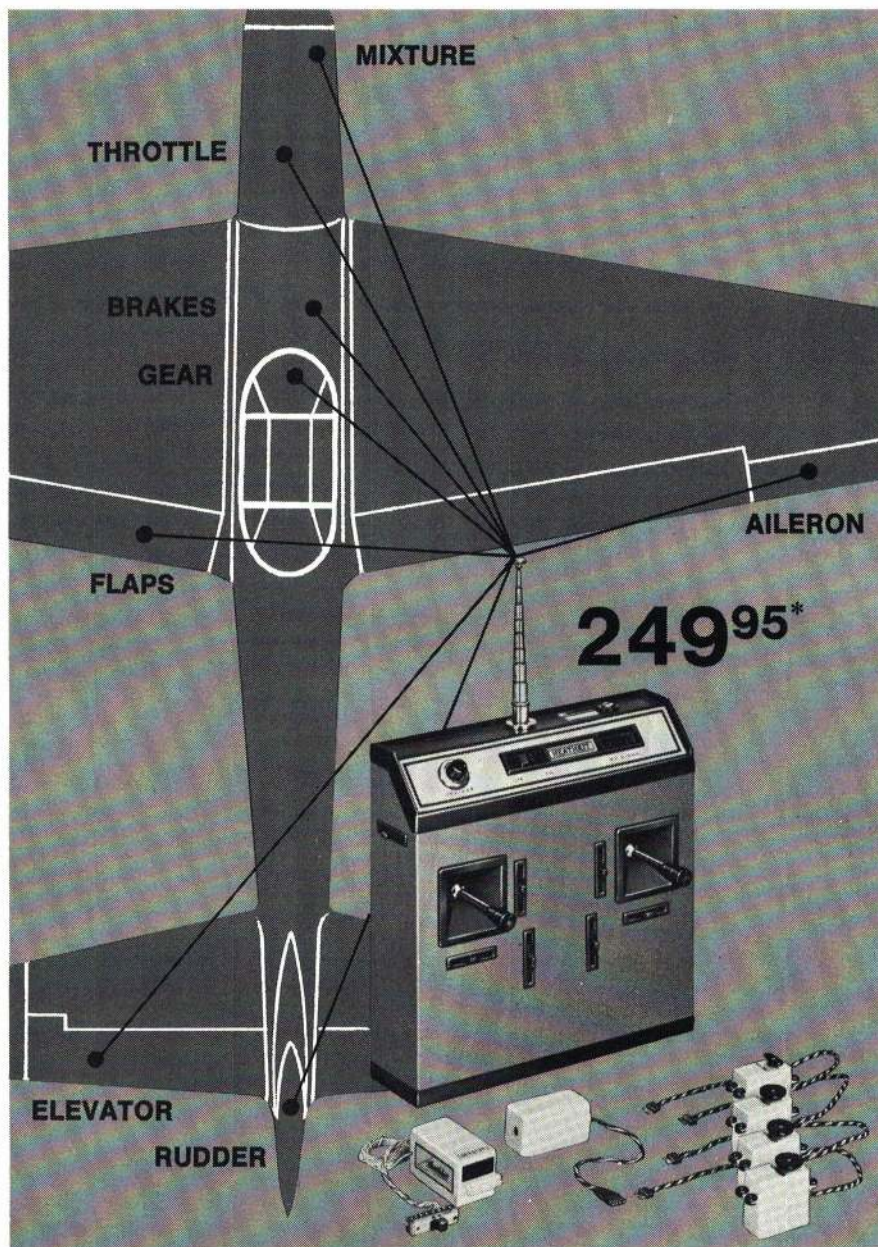

Everything's under control with the great new Heathkit 8-channel systems

Eight independent channels in a package no bigger than conventional full-house transmitters. Choice of single or dual stick control in 27, 53 and 72 MHz operation — with adjacent frequencies at no extra cost. Both transmitters have 2-position switch for landing gear, finger adjust tabs for auxiliary channels; trainer link jacks and "buddy buttons"; external charging jacks for simultaneous charging of transmitter & receiver batteries; 8 range controls for adjusting servo travel. System prices include transmitter, receiver, battery pack, choice of any 4 miniature or sub-miniature servos, all batteries (airborne weight with sub-miniature servos is a mere 11.3 oz.). For complete 8 channel flexibility & control, the Heathkit GD-405 systems are the only way to fly.

Complete Dual Stick System only **249.95***
Complete Single Stick System only **269.95***



The FREE
Heathkit
Catalog has
over 350
fun to
build kits.
Order
yours
today

HEATH COMPANY, Dept. 80-3
Benton Harbor, Michigan 49022

Please send FREE Heathkit Catalog.

Name _____

Address _____

City _____ State _____ Zip _____

Prices & specifications subject to change without notice.
*Mail order prices; F.O.B. factory. GX-270

Jay Lewis Presents...The Hobby Market

SPECIAL
Limited Time Only!!

Buy an EK 6 Ch. Champion . . . \$349.95

or
Buy a RCM 800 6-channel . . . \$380.00
and

Get your choice of one plane
and one motor free!

Pick from below:

Ugly Stick	Fox 40 R/C
Fun Fly	Fox Eagle 60
Lucky Fly	Enya 45 BB
Kaos	Enya 60 BB
Sr. Falcon	Webra 40
Fledgling	K&B 40 FR or RR
P-51	Veco 50
P-40	Merco 49

Merco 61

Don't pass up this deal
Pro and Beginner alike
SATISFACTION GUARANTEED

Specials: Super MonoKote Opaque 3/15.00, transparent 3/16.80, metallic 3/19.50; Solarfilm opaque 3/13.50, transparent 3/15.00, metallic 3/18.00; Super Shoe 2.35; MonoKote Iron 10.00; Goldberg Main Retracts 7.95; Goldberg full set 14.75; K&B standard long or short plugs 5.50 per card; K&B R/C plugs 11.25 per card; Fox R/C Plugs 7.95 per card; Dremel tool 27.00; Dremel delux home workshop with accessories 40.00; control line kits: Lucky Sport, Flitestreak, Ringmaster, Buster, Shoestring, 3/16.50; Miss Behave, Nobler, Dolphin, Akrobat, 12.00; Midwest ME 109, P-51, Skyraider, P-40, Ugly Stick, Kaos, 38.50; P-51 30.00; P-40 33.00; Sr. Falcon 25.00; Falcon 56 14.75; Tigertail 67.95; Windward 18.00; Windfree 23.50; Motors: Fox 35 11.99, 36 11.00, 40 13.25; R/C Motors: Fox Eagle 60 34.00; Enya 45 31.50, Enya 60 III BB 42.75; K&B 40 RR or FR 24.00 Veco 61, w/muffler 49.95; Webra 40 43.00, 61 Blackhead 60.00 (plenty of Webra parts), Props by the Doz. 25% off.

Send check or money order to the Hobby Market. Sorry, no C.O.D.'s. Texas residents please add 5% sales tax. Add 30 cents for insurance. Phone Day-(817) 626-1182; Nite-(817) 731-3174.

PO Box 2172 Ft. Worth, Texas 76101

along and choose an undersized one for this application. A slip clutch to drive the tail rotor is not needed when a 3/32" music wire drive shaft is used.

The shroud is constructed from .020" 2024 T3 aluminum with a very close fit around the engine. The baffles should not be fastened to the 1/16" thick mount. They should slide on this mount for ease of removing the shroud. The training gear attachment will be difficult when using a shroud because it is hard to tie the compression strut to a solid base. The ability to throw on training landing gear at any time is good for experimenting and to help teach future helicopter nuts! An angle bracket mounted sideways to the front top of the radio box projected beyond the engine shroud would be one solution.

The fuel reservoir shown is necessary when the tank installation is longitudinal. The fuel is constantly sloshing back and forth and cannot be picked up by a weighted fuel line. The ideal fuel tank installation is a lateral one right under the rotor shaft. A lateral installation would not need a reservoir and would feed the engine even through a loop. The fuel tank installation is not for CG purposes but a compromise between the engine and CG.

The scale-like landing gear should be self-explanatory except for the nose wheels. The nose wheels' main function is to provide nose weight. By taking a standard wheel and machining an aluminum and a steel hub for it, the CG can be shifted just by changing hubs.

SPIN A WIN! FLY Tornado

Get MORE travel-from-torque!
Every Grish-engineered
TORNADO Propeller has true pitch . . .
delivers MORE of your engine's power.



3-BLADE NYLON
Metallic Aluminum Color

PROPELLERS

YELLOW NYLON

	2 Blade Tractor	5-3 5-4 each	30¢
	2 Blade Pusher	6-3 6-4	35¢
		7-4 7-6 7-8	50¢
		8-4 8-6 8-8	65¢
	below in white, too		
7-8	6-3 6-4	35¢	9-4 9-6 9-7 9-8
85¢	8-6	85¢	10-4 10-6 85¢
	9-6 10-6	\$1	11-4 11-6 11-8 \$1
8-6 8-8	3 Blade Tractor		RC 12-4
\$1.25	5-3 5-4		12-5 12-6 \$1.50
9-6 10-6	6-3 6-4	50¢	
10-4	3 Blade Pusher		
\$1.50	6-3	50¢	

GRISH BROS.
ST. JOHN INDIANA 46373

You Just Put Your Hands On A Winner!



WRITE FOR A FREE BROCHURE TO:

RS SYSTEMS 2407 S. BROADWAY
SANTA ANA, CA. 92707

The secondary purpose is to allow the model to pitch forward and taxi. My landing gear struts are not made from aluminum but from unidirectional fiber-glass 1002S with BP 907 resin system. This is about the same glass that is used in archery bows. If you are not familiar with this glass, do not use it. The normal glass cloth and resin bought at a hardware store will not suffice. If you are still interested in this high temperature cure material, contact the 3M Co.

There was an error on my part in detailing -12 and -13, longitudinal control to the swashplate. This was pointed out to me by Dario Brisighella of Milwaukee, also building and now flying a highly modified SSP. I would like to point out that quite a few parts are not drawn like the original. I try to incorporate the way I would construct the part if I were to rebuild it.

General Changes

As of now, all of the controls are spring-loaded to eliminate backlash. The gimbal in the swashplate is also spring-loaded because of the wear on the pins.

Although shown on the plans, Rocket City missing links are no longer recommended. Find some .10 thick aluminum and cut it to 3/16" sq. like the end fittings in -12. This fitting coupled to a Du-Bro Kwik-Link will replace a missing link and will be much more reliable.

After about 40 hours running time on the Enya .45, the crankcase started throwing oil through the front engine bearing. This does not hurt the engine's performance, but makes for a messy model. A sealed bearing from PIC Design Corp. was installed with one seal removed on the outside. Sealed bearings add friction and only a seal on the inside is needed. The prop drive washer will need rework. A very slight power loss was observed but the oil slinging was almost completely cancelled.

Vendor supplied radio batteries have enough capacity for flying fixed wing aircraft, but I find that more time is logged on a helicopter during a day than a fixed wing. My batteries are C-sized Ni-Cads which give at least five hours flying time. The main disadvantage is that they weigh eight oz., but this is convenient if the model is tail heavy.

Originally, drill rod was used for the main rotor shaft. Drill rod, this length, will often distort when heat treated, so the material has been changed to 17-4PH which is a high-yield stainless steel even in the annealed condition. It is strong enough without a heat treatment and can still be machined. If you cannot find this material, send \$1.50 and I will supply a 10" length (501 Meadow Park La., Media, Pa. 19063).

The side struts on the original SSP have long since been removed. Their main function was to shorten the compression strut of the training landing gear, therefore lessening the chances of breakage. They are not essential and detract from whatever looks the SSP might have. The compression strut can go to the top of the main transmission structure.

I have also increased the height of the main transmission box by 1/4" to

Tired Of Cranking With A Bad Plug Or Weak Battery?



\$29.95

Post Paid Cent. U.S.A.
Ind. Res. Add 2%
Dealer Inquiries
Invited

CHARGE START is for YOU!

AMMETER INDICATION OF BATTERY &
PLUG CONDITION
SELF CONTAINED BATTERY AND CHARGER
PILOT LAMP AND REMOVABLE POWER CORD

DEVELOPED & PROVED THRU
EXTENSIVE FIELD TESTING

Send check or money order to:

D A ENTERPRISES
BOX 335, HAUBSTADT, INDIANA 47639
MANUFACTURERS FOR THE AERO MODELER



Feel and Fly like a **PRO!** ... with the GRAN PRIX R/C SYSTEM



The Gran Prix R/C System provides R/C flying at its best... at a Sunday Flyer price

\$399⁹⁵

• 6 CHANNELS • ANY FREQUENCY • DUAL STICKS •

NONE BETTER AT ANY PRICE!
(Single-Stick Model Add \$17.50)

The GRAN PRIX SYSTEM is guaranteed "ready to fly"... Install, charge batteries, and fly with **CONFIDENCE!**

Each Gran Prix System:

- has been flight tested in the air for 30 minutes or more.

- is packed with a certificate signed by test flyer giving date of flight.

**As we said,
"Fly with
CONFIDENCE!"**

Each component of the Gran Prix System has been carefully selected as best for its own function as well as to complement other components in the circuit, and each is operating at only a small fraction of its rated capacity. This provides an overload safety margin way beyond any demand that will be made of it.

All batteries are cycled three times prior to being installed in the system... and twice again before shipment. The system also goes through a complete cycle of operation to stabilize all components, by "burning in" before the actual flight test.

Is it any wonder we can offer a 120-day guarantee against defects in workmanship and materials, and say, "Install it and fly with **CONFIDENCE!**"

Write for complete brochure... the Gran Prix is only one of our six different types of systems.



13400-26 SATICOY STREET
NORTH HOLLYWOOD, CALIF. 91605
(213) 764-1488

MODEL AIRPLANE PRODUCT DESIGNER

Leading Midwestern airplane manufacturer needs top notch model airplane and product designer. Must have been in modeling at least 10 years and have basic background in all phases of flying models, especially in Control Line and Radio Control, with emphasis on Scale.

Should be proficient draftsman, excellent model builder and flyer. Also should be able to write instructions and follow product through to completion.

Many company benefits, and a ground floor opportunity for a creative designer. Salary commensurate with ability.

Send resume to:

DEPT. AAM
AMERICAN AIRCRAFT MODELER
733 15TH ST. N.W.
WASHINGTON, D.C. 20005

give better support to the main rotor shaft—not necessary but it helps.

My radio box is still .032 6061 T6 aluminum but .020 2024 T3 is recommended. The .020 is strong enough and will lighten the model by at least three oz. Several models have been built with .020 aluminum.

The tail boom should always be made easily removable and the fittings to it clamped on. The tail boom is next to the rotor blades as the most often replaced item.

In closing may I add, fellow helicopter nuts, you now should have enough information to go out and build a chopper capable of flying circles around my SSP-5. I vow not to be defeated and shall go into exile in my basement for the next three months to emerge with a bigger and better machine.

INDOOR MODELING

(Continued from page 16)

escapement with the control surfaces operated by a very light scissor spring would be appropriate for minimum drain as well as realism. Controls should take from two to five sec. to reach full deflection."

There you have it! Are you a free flighter who needs a rest from the grim pursuit of contest hardware? Live a

little! Build yourself a matchbox model, a helicopter, an ornithopter, an autogyro, a tail-first triplane—have fun!

Are you an RC pattern expert with a yen to be different? Build yourself an Indoor rubber-powered RC dirigible and have fun! Do you want a fun competition event? Add an unorthodox event to your club Indoor contest. Inspired by Bill's example, the D.C. Maxcutters have held an unorthodox event in connection with their annual Indoor meet for several years. The sole requirement is that the models be of unorthodox design and suitable for indoor flying. Judges give equal point emphasis to the three categories of design originality, neatness and quality of construction and duration. In the first three years of this event, the winning models were an Indoor helicopter, a condenser paper rogallo wing, an ornithopter, an autogyro, and a completely indescribable Jap tissue-covered multiplane. One thing is certain. The builders of these wildly different models had one thing in common—a great deal of fun!

This, it seems to me, is the message behind Bill's unique approach to modeling—modeling is fun! What's my advice to the competition weary expert? It's simple: Follow Bill Bigge's example. Be unorthodox! Let your imagination run wild. Build yourself a model which is completely unique and completely yours and have fun! That's what it's all about!

DREMEL MOTO-TOOL®



Sand and shape wood, fiberglass and foam parts.



Polish intake ports. Lighten pistons and rods.



Cut wire landing gears and slots for hinges.



Drill engine and equipment mounting holes.

From the minute you turn Moto-Tool on you'll feel its exceptional power (30,000 RPM) and balance that will help you work with confidence on any kind of job. It drills, polishes, carves, engraves, sands, deburrs, grinds with precision, speed, accuracy. What's more, you can power your way through wood, metal, plastic and many other materials. Best of all, you don't have to be a pro to handle it. Even beginners can get beautiful craftsmanlike results. Discover why thousands of hobbyists consider Moto-Tool the most useful power tool they ever owned. Ask for a demonstration at your hobby or hardware dealer. It'll bring out the expert in you.



Three deluxe kits with carrying case and 34 accessories from \$34.95 to \$49.95



DREMEL CREATIVE POWER TOOLS

Dept. 683C Dremel Mfg. Co., Racine, Wis. 53401

CAJUN QUEEN

(Continued from page 22)

gear plywood block before or after sheeting the wing. Either way be sure and make the channels for the linkages plenty loose. I have always used a PL-10 to retract all three gears but there is plenty of room if two servos are desired.

The finishing is done with whatever process works best for you. However, if you would like a fairly easy finishing process with excellent results, follow these steps.

First, do all the final sanding finishing with 180 Garnett paper. Give the whole airplane two fairly thin coats of dope. Sand with 280-400, just removing the wood fuzz. Now one more coat of clear dope to seal all the wood. Now use Skyloft, Silk or Silkspan and cover complete airplane except surfaces. Dope covering surface until all grain is filled (Skyloft three to four coats, Silk six to eight coats, Silkspan four to five coats). At this time I usually fit the canopy and finish the area around and under canopy. After this has dried, glue canopy on. Now take masking tape and tape off around stab and fin, dorsal, wing fillets, and canopy. Using Epoxolite make all fillets, smoothing to shape as close as possible. Care taken here will result in a much easier time sanding after they are dry.

Before removing tape, final sand fillets to shape. Now use 280-400 and lightly sand entire airplane. Spray or

PILOTS and **WHEELS** that add...
NEW!
SPORTSMAN



...REALISM and MOBILITY

MILITARY STANDARD RACING

Any one of these pilots will add realism to your favorite model. Molded of high impact, paintable styrene, you can color them to your choice.

1" Scale...\$.70 2" Scale... \$1.00
1 1/2" Scale... .90 2 1/2" Scale* 1.45
*Racing & Standard only



SMOOTH CONTOUR



VINTAGE AIRPLANE

SMOOTH CONTOUR TYPE

VINTAGE AIRPLANE TYPE

3/4" Dia. MS-1\$.55	3/4" Dia. MV-1\$.55
1" Dia. MS-265	1" Dia. MV-2\$.65
1 1/4" Dia. MS-375	1 1/4" Dia. MV-375
1 1/2" Dia. MS-495	1 1/2" Dia. MV-495
2 1/4" Dia. SC-1 1.85	1 7/8" Dia. VA-1 1.49
2 3/4" Dia. SC-2 2.65	2 1/2" Dia. VA-2 2.39
3 3/4" Dia. SC-3 3.65	3 3/8" Dia. VA-3 3.65
3 3/4" Dia. SC-4 4.75	3 3/4" Dia. VA-4 4.75
4 1/2" Dia. SC-5 7.25	4 3/8" Dia. VA-5 5.95
5 1/4" Dia. SC-6 8.55	5" Dia. VA-6 7.25

WILLIAMS
BROS.

SEND 25¢ FOR CATALOG

181 B Street
Dept. A
San Marcos, Calif. 92069

TOW MASTER

\$5.95



Send eight cent stamp for catalog.

Adj. tow hook \$1.00, Auto. rudder stop
Tow flags, Dacron towlines, Tongues, Precision thrust bearings, Hinges, Bushings, Bobbins, Hubs, Front end assembly, Aluminum tubes, Scales, Fuel & DT timers, Mylar flash tape, Pacifier fuel tanks, Glass booms, FAI engine mounts, and much much more!

F.A.I. Model Supply
10802 N. 33RD AVENUE
PHOENIX, ARIZONA 85029

FLITE BOXES BY INKY

AT LAST A GOOD SIZED ECONOMICAL BOX FOR RC-CL-FF
APPROX. SIZE 8 x 12 x 20



MODEL 50

LIGHT AND STURDY—30 MIN. ASSEMBLY
PARTS MACHINED—READY TO ASSEMBLE
KIT ONLY \$7.95 POSTPAID

SEND STAMPED SELF-ADDRESSED ENVELOPE FOR BROCHURES ON OTHER MODELS

SEND CHECK OR M.O. TO
INKY

10436 W. 4th Ave. Milwaukee, Wisconsin 53225

It brings out the expert in you

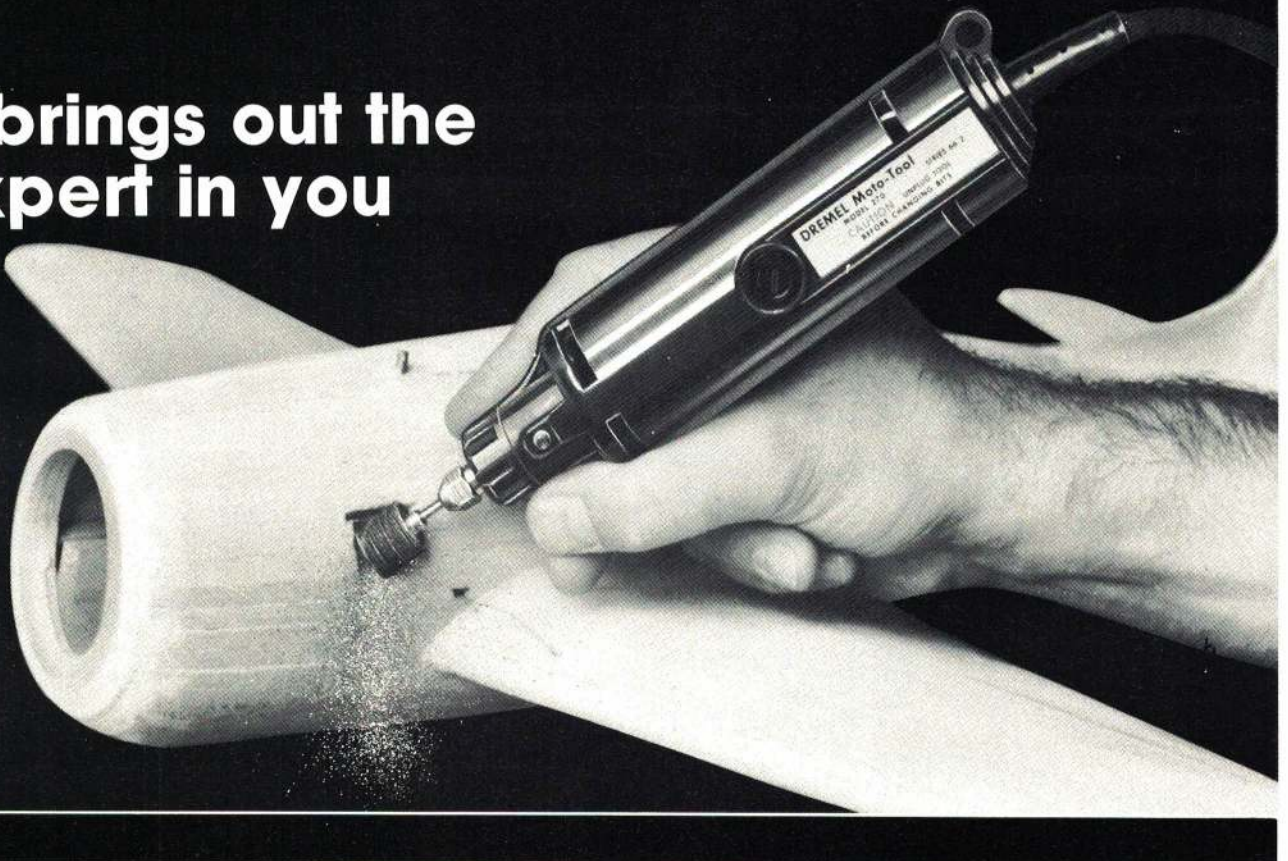

STEINGRAEBER

Wood ship kits designed for the serious model builder.

Both display models and ships designed for radio control operation are in the large variety from Steingraeber. Rib and plank construction with a choice of the finest fittings made. Over 20 different models available.



#1002 'Phoenix' Tugboat for RC \$26.95

Send for our catalogs:
 Steingraeber Catalog & Handbook\$2.00
 Boyd Models Catalog #10 1.00
 Constructo Color Ship Catalog 3.00
 "Ship Models and How To
 Build Them"—Hardcover 5.95

BOYD MODELS
 810 East 14th St Los Angeles, Calif. 90021

paint two coats of automotive universal primer. After this dries, wet sand with 180 just until the dope shows. (You'll find that most of the primer comes off.) From here on you can either use automotive acrylic lacquer or enamel. I prefer using two coats of acrylic enamel. This is absolutely fuelproof and is much lighter than several coats of lacquer. The beautiful thing about this enamel is it flash dries like lacquer and picks up no lint. If you use lacquer, be sure and plasticize it; the primer and dope should be plasticized whether lacquer or enamel is used. I use an additive to the enamel called polysol which makes the paint like iron when dry, but is not brittle. When trimming, be sure and seal the tape with a thin mixture of the color you are trimming over. This will leave a nice, sharp line when you pull your tape.

Now for the fun. If you have built the airplane true, you should be able to set all surfaces at neutral and never touch the trim. During the first flights, the airplane will stay exactly where you put it. The most common mistake is trying to fly the airplane too much. If it is true, the plane will fly like it is on a string. I set the elevator so I use almost full down on outside loops. The ailerons should be set so three rolls take about five to six sec. The rudder should be set to get maximum throw. On landing, try to keep the nose just above level flight and don't worry about slowing it down—the aileron will work all the way and the wing will hold true.

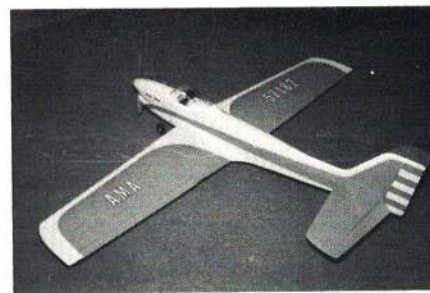

Note the symmetry of shapes for the wing, stabilizer, and rudder planforms. Lines blend together nicely.

I think that you will agree with me that you can have a pretty airplane and a good flying airplane at the same time.

FREE FLIGHT FINALS

(Continued from page 36)

here so much as it was consistent trim patterns, accurate needle valve settings, and avoiding downdrafts.

Texan Henry Spence became the only man to make a perfect score for the entire 15 rounds since the present format was adopted years ago. Twice a team member in the past, and third in the 1969 World Championships, Spence was clearly the master of the event, with only a slight bobble in the 14th round, when he launched slightly to the left of the wind and had a bad glide transition with stalls halfway down before hook-

X-ACTO. WHEN YOU NEED MORE THAN A KNIFE.

No. 82 X-acto Chest. Three knives for light, medium and heavy cutting, with 9 extra assorted blades. Comes in a natural-finish wood chest. \$4.95

No. 62 X-acto Double Knife Set. Complete with one knife for light to medium cutting, another for medium to heavy cutting. Plus 10 extra assorted blades. \$2.75

No. 1 X-acto Knife. The basic X-acto knife that started it all. Perfect for light to medium cutting. With replaceable blade. 65¢

Just because you're a hobbyist doesn't mean you have to use amateur tools. X-acto knives look professional because they are. They're precisely made and precision-balanced.

With X-acto you can be a wizard at train models, car miniatures, authentic planes and intricate ships. X-acto knives help you develop a professional touch at detail and a flair for corners and curves.

X-acto's 32 interchangeable blades have an uncanny way of taking on a thousand and one things that few other tools can do. They cut, carve, chisel, etch, notch, scrape, slice, slit and trim perfectly.

X-acto.

It brings out the perfectionist in you.

x-acto® Dept. 12
 48-41 Van Dam St., L.I.C., N.Y. 11101

X-acto—Sold at leading hobby, art and department stores.

BACHMANN

THE WORLD'S LARGEST AIR FORCE

MINI-PLANES

68. B-29 Superfortress

54. MU-2B

61. Polikarpov

ADD
6
MORE

64. Morane-Saulnier

71. De Havilland Mosquito

72. Douglas DC-3

79¢
each

- AUTHENTIC • EXACT SCALE • HAND DECORATED
- MICRO DETAILING • MOVING PARTS • FULLY ASSEMBLED

BACHMANN

Quality Since 1833
PHILADELPHIA, PENNSYLVANIA 19124



AAM SUDDEN SERVICE PLANS

FULL-SIZE PLANS—SHIPPED FIRST CLASS MAIL WITHIN 48 HOURS—NO EXTRA CHARGE

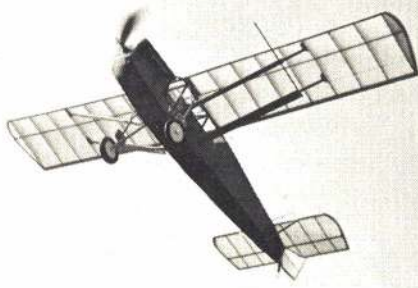

No. 0333, Curtiss Robin

THIS MONTH'S PLANS

No. 0331, Cajun Queen—Frequent winner in RC Pattern down South is Lou Penrod's graceful design. Takes 60's and retracts. \$3.75

No. 0332, Macchi C. 202—Semi-scale profile stunter for 15 through 25 size engines, great for Slow Combat and practicing the pattern. Flaps. \$2.50

No. 0333, Curtiss Robin—Rubber scale model for AMA events. Easy flying. Stick and tissue. Square shape builds easily. \$2.00

No. 0231, Mustunt I—Primary profile fuselage, upright .35 engine, thick airfoil stunt trainer. By Al Rabe. \$2.25

No. 0232, Mustunt II—Advanced stunt trainer, same aerodynamics as Mustunt I but fully shaped fuselage and upright .35 engine capable of winning any meet. \$2.75

No. 0233, Mustunt III—Nats-level 35-powered non-scale competition CL stunter is exactly like Mustunt II but has many detail refinements and tapered wing. \$1.00. You'll need 0232 for complete construction details, order separately.

No. 0234, Super Goose—Very unusual flying wing RC has swept forward wings for better flying, balance, and construction. Uses a 40, stunts real well for fun flying. \$3.75

No. 0133, Mo-Bipe—Contest-winning Navy Carrier profile fuselage biplane. Thin wings go fast and slow. Takes a throttled 35. \$1.75

No. 0132, Viper—Toledo Design and Finish winner, big State-of-the-Art Pattern ship by Dario Brisighella, Sr. for good 60s and retracts. \$2.00

No. 0131, 720 Turn—Clarence Haight design Class B FF. Conventional design, high pylon wing, big plan. \$4.00

No. 1224, Snoopy—Sport flyer and trainer for 09 thru 35. Can use Top Flite Headmaster wing. \$2.25

No. 1223, Quicky 500—Glen Spickler's club pylon racer goes fast but is very quick-building, long-lasting, easy to fly and land. For TR type 40s. Great for grass-field sites. \$2.75

No. 1222, David—An AI Nordic for competition with A2s is stronger, smaller, easier to make, and has lower wing loading. \$1.75

No. 1221, Spitfire—Highly detailed, two sheet plans for 60-powered retract-gear CL scale model. A Nats winner and seventh in CL Scale World Champs. \$7.00

No. 1122, Sweet Pea—"V" tailed CL stunter by Dennis Adamisin is consistent winner with semi-scale Good-year-racer appearance. Takes smooth 35 or muffled 40. \$3.50

No. 1121, Warlock—Mid-wing, tandem bicycle retractable, all-flying stab, and swept wing are features of this 60-powered Pattern ship by Jim Wilmot. Large plan. \$6.50

No. 1023, Quasimodo—An odd-looking four-channel RC Sport job for 35s. Shoulder wing, tail dragger. A fun flyer. \$4.00

No. 1022, Lockheed 51—Unique highly-detailed scale biplane of Lockheed's first airplanes. Original dates to 1921. Design by M. Groves, uses a 40. Two sheets. \$7.00

No. 1021, Bronco—A Class I or II Navy Carrier plane for two 19s or two 29s of the OV-1A C.O.I.N. fighter. The large plan sheets. \$6.00

No. 0923, Vertigo—A CL vertical take-off-and-landing biplane. Uses throttled 19 for power. Really flies, lots of fun. \$2.75

No. 0922, Aqua-Vent Floats—Simple curves make these easy to build. Sized for 15 to 30 powered planes. Designed for quick lift-off with low power. \$2.50

No. 0921, Hot Pants—Jerry Nelson's large-bodied, realistic-looking, home-built type RC Pattern design. Smooth flyer uses all-moving stab. \$4.00

No. 0825, S.S.P. RC Helicopter—Gene Rock's very successful large trainer helicopter needs only 40 to 45 size engine. Designed for home builder with minimum machined parts, gyro-stabilized tail rotor, all belt drive, 4 channel radios. \$6.00. Also recommended is Plan No. 0826 with full-size drawings for all special machined parts. \$2.00

AAM will present up-dates on the design during 1973 as experience of readers and designer shows need.

No. 0824, Ryan SC—Unusual 049 free flight scale model is low winger with excellent flight stability. Flies fast and handles wind easily. \$2.75

No. 0823, Apteryx—New style mylar-over-foam wing on fast, tough, AMA Combat plane by Robert Mellen. Construction offers perfect airfoil and tapered wing. \$2.25

No. 0822, Nemesis II—Howard Rush's winning AMA Combat ship. Ultra-light, balsa and silk, very quick. \$2.25

No. 0821, Capstan—For one- or two-channel RC, a small sport/scale all-balsa glider. Has a fine glide. \$2.00

No. 0723, Quickle Mk 4—RC competitor for Class A and B. Conventional looking low winger flies easily, builds very fast. \$2.00

No. 0722, Wizrod 350—Ron St. Jean's combination of past FF power winners in a 350 sq. in. 049 screamer. \$1.75

No. 0721, Douglas Devastator—Navy Carrier competitor for 40 or 60 of colorful shipboard fighter. A tough plane and a winner. \$3.00

No. 0623, Chance Vought "Skimmer"—U.S. Navy experimental shipboard fighter is real flying saucer. For Profile Carrier events, by Frank Scott. \$4.50

No. 0622, Denight Special—Well updated four-year-old Forum I racer by deBolt has many unique features for Speed. All balsa construction. Two-sheet plans. \$2.00

No. 0621, So-Long—Miniaturized Old-Timer for 020 Power event and Sport flying. Easy to make. \$1.50

No. 0523, Pegasus—A take-apart RC job designed for transportation in its own box. Full house with a 19, stunts well. \$2.50

No. 0522, Lil' Rebel—Fast and very durable 15 Goodyear CL racer is a consistent winner. \$2.25

No. 0521, Satellite 1000—Huge and highly-detailed plans for one of FF's most winning designs. For screaming 40s. \$8.50

No. 0424, Dragonette—Compact version of Kraft's Dragon Fli uses hot 40 and flies just like a big one—fast and smooth. \$3.00

No. 0423, Squeeze-Banger—FAI Combat anyone? Fast flying 15 ship from Canada is a winner. \$2.00

No. 0422, RCX4—Bat-like winged Sport RC Plane for big motors, 4-channels, and crowd pleasing flights. \$4.50

No. 0421, Quarter Pint—A 020-powered Tenderfoot free flight patterned after an antique design of 30 years ago. With decal. \$2.00

No. 0324, 2T—ACE-foam-winged RC trainer for 049 power carries 2-channel bricks with ease. Ample wing area for long glides too. \$2.00

No. 0323, Two for the Show—Biplane CL Stunt for 049 Tee Dee. This one offers precision flying in small areas, great for practice. \$1.50

No. 0322, Little Bird—Midwing RC pattern plane handles wide range of power up to 71s, yet is small in size. \$3.50

No. 0321, Turbo-Pilatus Porter—Fine flying CO2 or rubber-powered FF scale model and scale floats for ROW. All on one plan. \$1.50

No. 0224, Cardinal—Excellent FAI European-type RC Pattern plane of foam/balsa construction. Up-to-date ship if for 60s, suitable for retracts. \$4.50

No. 0223, Canard Drop-Off—Rubber pusher Sport flyer drops its prop and rubber when unwound, then drops a piggy-back glider. All balsa and flies great. \$2.00

No. 0222, BV-170—Three 35s power this sort-of-scale German profile fighter. It is big, pulls hard in flight, stunts too. \$4.75

No. 0221, Big Flapper—Large high wing is docile flyer for a 60 engine and four channels. Nice trainer/sport plane. \$3.50

No. 0124, P-38—Semi-scale WWII fighter with single 049 flies rudder-only pulse RC with ACE mini-foam wings, others usable. \$1.25

No. 0123, Nifty Novice—049 thru 15 power for monoplane or biplane Tenderfoot CL trainer. With power, bipe is stunable. SPECIAL PRICE \$1.00, decal included.

AAM PLAN SERVICE

733 Fifteenth Street, N. W. Washington, D. C. 20005

GENTLEMEN: Please send the plans listed by First Class Mail, at no extra charge. I enclose \$ _____ for

NAME _____

ADDRESS _____

CITY, STATE, ZIP _____

The rates quoted above pertain to the U. S. A., Canada, APO's, and FPO's. For foreign please add 25% for postage.

PLAN NO. COST

_____	_____
_____	_____
_____	_____
_____	_____
_____	_____
_____	_____
_____	_____
_____	_____
_____	_____
_____	_____

Why not order our complete plans catalog @ \$0.25?

TOTAL: _____

No. 0122, Pay-Up—TeeDee 020-powered AMA Pay Load event winner also nice for sport FF. Simple and sturdy. \$1.50

No. 0121, Penguin—Unusual scale CL flying model of post-WWI pre-flight trainer. Simple and RC-able. Uses 19 to 35 engine. Three-views on plan. \$2.50

No. 0125, Firecracker—FAI scale RC pylon racer with special fast airfoil and homemade retracts (in text), a winner by Bob Root. \$3.50

No. 1213, Canus—Sixty-powered and large-size FAI aerobatic RC plane. Very quick building. \$4.00

No. 1212, Brooklyn Dodger—Sal Taibi's great old-timer FF job presented as it was by Bob Harrah. For ignition 23-35 or smaller glow engine. \$1.75

No. 1211, Fireball—Jim Walker's great design presented as it was by Bruce Lund. For ignition 23s or smaller on glow. \$2.00

No. 1113, Bippi-Bipe—Delightful scale-like rudder-only or GG model for single channel and 09 engine. A fun plane. \$2.75

No. 1112, Buster—Built-up Profile Goodyear racer well-streamlined and a winner. For hot 15s. \$1.75.

No. 1111, Longster—Large-size free flight scale ship for 09 power, also ideal as small RC. Construction similar to real plane. \$2.75

No. 1015, Marut—Named for the Wind Spirit. Designed for windy weather CL contests. Large-size jet appearance uses 45 engine. Two sheets. \$4.50

No. 1013, Hi-Pro—Highly proficient slope/thermal soarer. Build several versions from these plans. Balsa wing and glass fuselage. \$3.50

No. 1012, Peregrine—All-out RC slope soaring racer for ailerons and elevator. Balsa fuselage with foam wing. \$3.50

No. 1011, FAI Man—Competition FAI free flight job for screaming 15s. Simplified construction with warp-preventing wing. Build a winner. \$2.75

No. 0914, Sakitumi—Highly-developed 40-gram Wakefield plane by Brian Donn features latest trends in gadgets and design. Well-detailed plan. \$3.00

No. 0913, ACE High—Featherweight 049-powered RO glider uses a set of ACE R/C foam taper and constant chord wing sets. \$2.25

No. 0912, Killer—Fast, responsive combat plane. All-balsa for 35s has many wins. \$3.00

No. 0911, Fletcher—McCullough's magnificent tri-geared, low-wing crop duster scale job for 60s. Generous area and moments. All balsa. Highly-detailed plans on two sheets. \$7.50

No. 0814, Flying Fortress—Not a scale plane, but a novelty CL flying medieval castle for a 19. \$2.75

No. 0813, Pogo—Model of Owl Racer for Formula I features midwing, low stab, non-checked cowl. Very stable and plenty fast. By Bob Morse. \$3.50

No. 0812, Hot Canary—Unique Formula II/FAI racing biplane by Bob Sigelkoff. Although unusual-looking, it is fast and quickly built. \$3.25

No. 0811, Douglas Mailplane—Large FF scale of Western Air Lines M-2 biplane. For 09 power. Could fly with light radio. \$3.00

No. 0714, Helldiver—Semi-scale CL model of WW II torpedo bomber builds fast and is rugged. \$1.50

No. 0713, I.F.O.—Would you believe a FF 020-powered flying saucer which really flies? Built-up construction looks real. \$1.00

No. 0712, Bonanza/Debonair—Build either V-tail or conventional version of this popular fast light plane for full-house radio and a strong 60. Fine-flying ships, foam wing construction. \$5.00

No. 0711, Phoenix 5—Don Lowe's latest in a series of swept-wing competition stunts for 60 and retracts. \$3.00

No. 0615, Santana—Jon Davis' contest-winning towliner A/1. Uses fiberglass boom, stiff warp-resistant wing. \$2.00

ing a thermal. His closest rival, Earl Thompson of California, suffered a devastating blow in the final round when his perfect score was ruined by a down-draft after he was forced to fly his reserve model owing to damage to the No. 1 on landing in round 14. The 132-sec. flight dropped him to fifth place from a tie for first, and off the team. The benefactor was Tommy McLaughlin of Florida who moved up to the third slot behind Frank Wolfe of New York.

Wakefield, where a miniscule 40 grams of Pirelli rubber must be wound near the breaking point each flight to propel an eight to nine oz. airplane high enough to max, was predictably a thermal-picking duel with bubble machines, mylar streamers, and electronic temperature recorders widely utilized to spot the elusive rising air. Predictably, Frank Parmenter and Bob White (third in the 1971 World Championships) repeated as team members in the first and second spots with comfortable leads throughout the meet. But the third slot went to 19-year-old Jon Davis of Albuquerque, New Mexico, who maintained his composure under pressure and came from behind to edge out many more experienced former Wakefield team members, such as Jim Patterson, who was fourth, three seconds behind!

The Nordic towline gliders, with their spindly six to seven ft. wings were most affected by the wind. Wings snapped, gliders veered uncontrollably into the ground on tow, and most contestants found it extremely difficult to put their model in a thermal on the 164-ft. towlines, which were not long enough to raise the gliders out of strong ground turbulence. Tactical flying and thermal picking before towing were virtually forsaken as it became more important merely to get the model up to the top of the towline, and then, if the wings didn't break, hope for a thermal to come through. As an indicator of how much this affected the level of performance, George Zenakis was in the top three late in the final day with a score that included two zero rounds. Former team member Hugh Langevin (fifth at 1971 World Championships) was first with a comfortable lead, followed by a jubilant Paul Crowley of Detroit. Newcomer Vince Croghan of Baltimore, Maryland, eased into third position to complete the team flying a design that seemed well suited to the conditions.

In all, a very interesting contest despite the bad weather, and congratulations are due the nine winners, who should represent their country well next year in Austria. Thanks are also due to Casey Hornbeck, the event organizer, and to the sponsoring clubs, The Cliff Cloud Climbers of Dallas, and The Fort Worth Plainsmen.

Hire the handicapped.



PUBLIC ADVERTISING SYSTEM
A DIVISION OF THE SCHOOL OF VISUAL ARTS



Graupner

THE BEST IN FLYING

CUMULUS

Here is the king of sailplanes, by the king of quality: Graupner. Designed for towline and slope soaring, or power assisted thermal flying, 2 channel: rudder and elevator. Wing span 110 1/4", weight (ready to fly), 56 oz. Foam wings are already balsa covered and sanded, fuselage is one piece of plastic ready to paint, all other parts sanded, and ready for "film" or paint.



\$169.95

CIRRUS

The Cirrus is a 1/6 scale model of a full size sailplane manufactured in Germany. Wing span of 118 inches, overall fuselage length of 49 inches. Fuselage is basically composed of three high impact molded plastic pieces. Wings, tail and stabilizer, are built up in the conventional manner. A high performance soarer for 2 channel R.C.

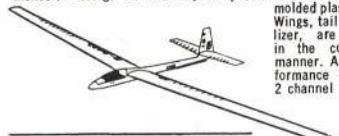

\$79.98

KWIK FLY MK III

This is the world champion model designed by Phil Kraft for acrobatics. Wing span of 59 1/2 inches and will take up to a .60 for 4 channel RC equipment. This model is easy to build due to its extensive pre-fabrication.



\$95.98

Dealers, Wholesalers, Write to AHM Today to Order These Hot Items.

Catalogs: CA-27—Gas Model Cat. 10c.
CA-15—1971 4-color plastic kit cat. (new), 50c. CA-24—1972 Airfix color kit. 68 pages \$1.50. CA-25—Airfix price list (no pictures) 10c. Allow five weeks for catalogs, by third class mail. For first class mail add 25c for each cat., individually, or 75c for all catalogs, normal ten days delivery.

Mail Orders—try your AHM dealer first. If he cannot supply items desired, send his name and address with your order. Orders less than \$3.00, add 50c handling charge. If the service is not completed promptly, write boss, 1240 Gilbert Road, Meadowbrook, Pa., 19046. For prompt attention to mail order, address to:

CS 2062



ASSOCIATED HOBBY MANUFACTURERS, INC.
627 E. Cayuga St., Phila., Pa. 19120

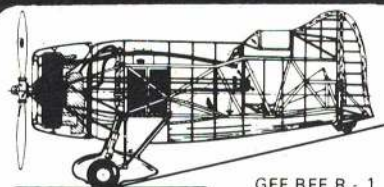

GEE BEE R - 1

the national
AIR RACERS
in 3-VIEWS 1929-1949

3-Views galore - all of the great classic Thompson, Bendix, Greve and Goodyear air racers are shown in magnificently detailed drawings - AND THERE IS MORE - Voluminous notes give the full story of each racer - pilots - race results - construction and performance data - color schemes and markings - everything the race enthusiast, modeler, and historian could desire. The Golden Era is recreated on large, crisply printed 8 1/2 x 11 pages covering over 90 aircraft.

American Aircraft Modeler - provides excellent 3-views - truly outstanding research.

R/C Modeler - This book is full of drawings and construction details - we recommend this book as invaluable to anyone interested in scale details of the famous air racers.

Airpower - The drawings are accurate, profuse and very thorough. Cleveland Press - Aviation Editor, a treasure of plans and information.

\$3.95
POSTAGE INCLUDED

The Diane Publishing Company
P. O. Box 2726 Dept. 1
Rochester, New York 14626
New York State residents please include sales tax.



Name _____
Street _____
City _____
State _____ Zip _____

R/C BOATERS:

PARALLEL

EXCUSE US IF WE STRUT A BIT!



Made of high tensile strength extruded aluminum

PARALLEL STRUT \$295 ea.

Complete with
2 Nyliner Bearings
4 Screws & T-Nuts

1 1/4" Depth
1 1/8" Depth
1" Depth
3/8" Depth
3/4" Depth
1 1/2" Depth

3/16" Boss
3/8" Boss

Shaft—steel
\$150 ea.

3 1/4" long

3/16" DIA. PROPELLER SHAFT & DRIVE DOG COMBINATION

To be used with any of Parallel Struts at left.

Drive Dog—Hardened, plated steel supplied with 8-32 cup point set screw

3/16" Bore
3/16" long

BALL THRUST BEARING

7/16" O.D.—\$1.80
3/8" O.D.—2.50

LOWER UNIVERSAL JOINT \$235 set

Use with Parallel Strut

Hardened, plated steel

3/16" to 3/8" shaft—OC610 F & M—7/16"
5/32" to 3/16" shaft—OC509 F & M—3/8"

STREAMLINED TAIL NUT plated

1 3/16" long.

10-32 thread, 75c ea.

OC6PN—7/16"
OC6PNM—3/8"

OCTURA MODELS

If dealer cannot supply you—order direct—add 10% for postage and handling—Illinois customers include Sales Tax.
8148 NO. MILWAUKEE AVE. • NILES, ILLINOIS 60648

GO FOR BROKE

(Continued from page 70)



Two spectacular models of the Sea Fury.

finally began to build my Sea Fury wing.

I am through testing airfoils, for now, at least. I think the point of diminishing returns has been reached and look for little additional improvement in practical stunt wings. I say "practical" because: 25% is about as thick as a wing can be made and still look reasonably attractive (though thicker wings would, no doubt, lift more); stunt flaps are near the limit of development; practical leading edge devices could be used but would hurt appearance; and the only remaining area of possible significant improvement is boundary layer control which, at present, looks too gimmicky and unreliable for heavy competition use. It seems now that optimum practical results will be obtained by a thick airfoil with moderate leading edge radius, large flaps, and a profiled trailing edge. Every effort should be made to keep the point of maximum thickness as far forward as smooth transitioning of airfoil curvature will permit.

While I used the asymmetrical 25-22 on both Sea Furys, I am not recommending asymmetrical airfoils for general use. They are a "special" solution to a "special" problem. Tests would seem to indicate that I am getting about half again more lift now from these thick wings than would normally be obtained from conventional stunt wings of the same area. Over a thousand flights with my Sea Furys and almost 500 more on Mustunts seem to verify this approximation.

Excepting the outboard dihedral breaks which subsequently caused little or no difficulty in either building or flying, the Sea Fury wing is an unusually fine choice for a semi-scale stunt ship. The clipped tip elliptical layout packs much more area into a given span than a straight taper, and provides for convenient mounting of adjustable leadouts. Also, the Sea Fury's unusually small wing tips themselves helped to avoid, almost completely, high lift wing tip yaw sensitivity which has made other big flap stunt ships more difficult to trim to contest smoothness. The Sea Fury also has adequate leading edge sweep for stability, scale dihedral perfect for proper vertical location of leadout exits and, of course, the visually effective elliptical platform which looks so good in the air.

ADD TO YOUR



Collector's Series
NOW!

12
EXCITING MODELS
FROM WHICH
TO CHOOSE



The Complete
"Collector's Series"
includes:

FOKKER E.III	\$1.70
SOPWITH TRIPLANE	1.70
NIEUPORT 28C.1	1.70
FOKKER E.V	1.70
BOEING F4B-4	1.70
BREGUET 14	2.00
ALBATROS C.III	2.00
PFALZ D.III	2.00
BOEING P-26A	2.00
DE HAVILLAND DH-10A	3.00
GOtha G.V	3.00

OTHERS TO COME

Authentically Detailed Plastic Kits of the Most Famous
World War I and 'tween Wars Fighter and Bomber Planes

If you haven't started your "Collector's Series" . . . START TODAY! These exciting kits in 1/48 Scale are accurate in every detail. They convey the thrill and romance of the era that was the birth of aviation history. Beautifully packaged with full color action illustrations on the box, they come complete with detailed cockpit, machine guns, engine, pilot, or ground crew, or both, decals of authentic markings, and battle terrain display base. You'll want them all once you have seen them. That's why we call them the "Collector's Series".



K&B MANUFACTURING

DIVISION OF AURORA PRODUCTS CORP
12152 WOODRUFF AVE. DOWNEY, CALIFORNIA 90241

SEND TODAY!

Enclosed is 25¢ for beautifully illustrated, full color catalog of complete line.

Name _____

Address _____

City _____ State _____ Zip _____

AAM

EXCLUSIVE FOR THE MODELER
FROM DEMBROS HOBBIES

CHECK THE STARS THAT
MAKE UP STARFLITE

STAR-
FLITE
\$199.95



- ☆ Extra Transmitter Power Output
- ☆ Fixed Frame Rate Logic
- ☆ New Rand 2 Axis Sticks
- ☆ White Vinyl-Clad Trans Case
- ☆ Provisions for Buddy Box Installation
- ☆ Lowest Cost Basic—Full House System
- ☆ Charger and All Nicads Included
- ☆ New 2-Wire Battery Pack
- ☆ New 3-Wire Servos
- ☆ I.C. CHIP Receiver Decoder
- ☆ I.C. CHIP Bridge Servo Amplifier
- ☆ Small Size—Lightweight
- ☆ 90-Day Factory Warranty
- ☆ Choice of Servos—C-E1, C-E2, C-E3
- ☆ Choice of Flat or Square Battery Pack

27 MHZ w/C-E1 servos ● 72 MHZ, add \$10.00
C-E2 and C-E3 servos, add \$3.00 per servo

The full retail of this high quality radio will be \$269.95 — introductory offer of \$199.95 good 'til January 31, 1973

Dembros
HOBBIES, INC. 50 LAKE ST. WASHUQUAH, N.H. 03086
AREA CODE 603 / 882-9492

COMPETITIVE PRICES Plus NO SALES TAX IN N.H.

For fast service send M.O. or bank check. We allow personal checks to clear before we ship. Bank, American and Master Charge accepted. Include M.C. Interbank Number. (lower left corner) and expiration date.

Since "going for broke" was the order of the day, I decided to use a shock absorbing landing gear to overcome the conventional gear airplane's tendency to bounce that cost me the 1970 Nats. They only add 1/2 oz. each and work well. As a result, the Sea Fury seldom bounces, even on a hard landing. Also, spectators seem to enjoy watching the Sea Fury "float" over a rough surface with the gear working to follow the contour.

As I pointed out earlier, the extra weight of the larger engine indicated the desirability of a short nose. By molding the fuselage from balsa and using all built-up tail surfaces, a really long tail moment should be possible. The "go for broke" attitude prevailed again. The fuselage was drawn exact scale except for relocating the wing leading edge one in. aft. This still left me with the rather unusual seven-in. nose moment (wing leading edge to prop) and 20 1/2 in. tail moment (flap hinge to elevator hinge)!

The spinner would be the 3 1/2 in. Williams P-51 and the cowling would be six in. across! Oh well, I figured I could use the space inside. This would be one airplane nobody mistook for a modified Nobler.

The front end of the Sea Fury fuselage quickly became so complicated in design that I had to build a forward fuselage mock-up to properly locate the firewall, engine mounts, 6.5 oz. adjustable fuel tank, cooling bypasses and the muffler installation. It soon became apparent that no commercial muffler would work without making the fuselage impossibly difficult to build, so I decided to design my own. It would have to be short—only two in. long—to stay entirely in the engine compartment. Only the tailpipe would run down the left cooling air bypass. Hoping to avoid power loss from my 2/3 length muffler, I increased its diameter to 1 1/2 in. The extra 50% diameter would increase the internal volume of my

PEANUT SCALE!

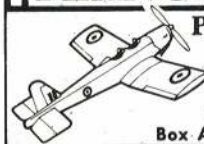

PLANS • WHEELS
& SUPPLIES

Complete catalog 25c
W. C. Hannan, Graphics
Box A, Escondido, Ca. 92025

SUPERSCALE

WW II SCALE AIRCRAFT PLANS

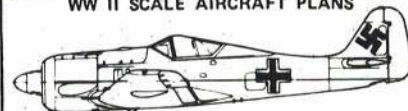

Send \$.25 for DEPT. CA71
Brochure to: Box 201 Arlington, Texas 76010

SEA KING RC MOTOR LAUNCH



A FIRST FOR BILLING® BOATS

Famous for real planked hull construction in all of their other boat kits, BILLING now introduces a durable vacuum formed polyester hull. This 28" model does have a frame, deck, and cabins of wood. Real brass fittings. Shelf model kit.

OPTIONAL RC CONVERSION KIT FOR 2 CHANNEL AT EXTRA COST

KAYEFF, INC.
511 Campesina Road
Arcadia, Calif. 91006

See Your Hobby Dealer... Dozens of beautiful models; some advertised in recent issues of this magazine. If dealer does not stock, send check or money order for direct, prompt shipment. California orders must add 5 % sales tax. Satisfaction guaranteed.

SCALE INSTRUMENT KITS

Each kit contains six metal instrument cases, turned and plated. Six glasses and backs to fit cases. Twenty typical instrument faces included. Complete with instructions, easy to install. **\$1.75**

RIM DIA. 1/4 - 5/16 - 3/8 - 7/16 - 1/2 Per Kit Size

Tatone
"CLEAN-CUT"
RAZOR BLADES

for
**MODEL BUILDING
ARTS & CRAFTS**

pkg. of 10... **59¢**
NO. 500

TATONE STEERABLE NOSE GEAR KITS

BELLY MOUNT

For all engines 15 to 74

R/C ENGINE-GEAR MOUNT KIT

Give name and disp. of engine when ordering.

\$5.95 each

May be inverted and bolted to outside of fuselage **\$4.95 each**

Wheels not included

New!

- No nose gear mounts
- Teflon bushings on all mounts no metal to metal contact
- Shock absorbing steering arm
- Adjustable length 1/2 wire gear
- 1/2 wire on 43-74 engine mounts

Kits include all necessary mounting hardware

At All Leading Dealers

MODEL I
1 1/4" x 1 3/8"

BULKHEAD MOUNT

MODEL II
1 1/4" x 2 1/4"

R/C HINGES

No noise, smooth action. Simple to install, invisible to the eye. Best by test for all Gullwing Ghost and Multi planes.

42¢

TATONE PRODUCTS

1208 GENEVA AVE. SAN FRANCISCO, CA. 94112

Tatone Engine-NEW-ities

Pat. Pend
"POCKET BOOSTER"

- 1-23 VOLTS
- Fluor. glow
- Rechargeable NICKEL CADMIUM battery
- Hung on connector makes this unit the most compact, easiest to use starting battery yet devised. Fits all engines.

Cat. No. 95
BOOSTER CHARGER
4.25 Cat. No. 96

"Chicken Stick"
Engine Starter

- Prevents cut fingers
- Ideal for cheap Nylon grips
- Starts engines faster

98¢

Cat. No. 51

See your dealer or order direct add 25¢ for postage & handling. Calif. Res. add 5% Tax

"PEACE PIPE" MUFFLERS

models for all size port engines. No fitting req.

No. 101 .09-.19
No. 102 .29-.40
No. 103 .45-.65

\$4.95

EXTENDED
No. 101L .09-.19
No. 102L .29-.40
No. 103L .45-.65

\$5.95

"HANG ON"
for WET or DRY cells

- Simple to use
- No clips to connect, tangle or short out
- Adjustable for all size engines, 15A-80
- Wire and battery terminals included

\$1.49 Cat. No. 90

ENGINE TEST UNIT
Cat. No. 80

- Cast aluminum engine mount
- Adjustable for all size engines
- 4 Oz. Tank. Tank bracket, plumbing and all mounting stress

RADIAL-BEAM ENGINE MOUNTS

CLASS	BEAM LENGTH	LONG OR SHORT	..\$1.75
1/2A	LONG OR SHORT	..2.25	
.09	SHORT ONLY	..2.25	
.15	LONG OR SHORT	..2.25	
.19	LONG OR SHORT	..2.25	
.29-.40	LONG OR SHORT	..2.50	
.45-.59	LONG ONLY	..3.00	
.60	SHORT ONLY	..3.50	
.60	SHORT ONLY	..3.00	
	K&B 15 73	..2.50	

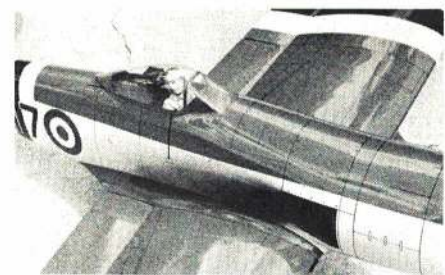

You'd look away too if you saw the ground so close, so often. Note rivet detail; simple, clean cockpit.

"shorty" to 140% of average commercial .60 mufflers. To further reduce power loss, I made my muffler a "flow through" or "extractor" type with a minimum tube ID of 1/2 in. The muffler was machined for me by Bob Wilder. It weighed 2 1/4 oz. installed (later reduced to 1 7/8 oz.). I was surprised at the sound suppression effected by my rather breezy contraption on the test stand and considering that it is completely housed inside the cowling of the Sea Fury, it rates as far more effective than just a "legalizer." In practice, it performed exactly as I had hoped, by effectively muffling the engine without causing any obvious power loss or increase in operating temperature.

Actual construction of the Sea Fury was at best tedious, laborious, and difficult, with its molds, jigs, mockups, and machining. I was shooting for a final weight in the low 60 oz. range and was more than a little unhappy when I realized it was going to be impossible. Where did I go wrong? Hadn't I done all the necessary molding, sanding, and constructing of built-up assemblies? Well, yes, but as I looked at the finished Sea Fury sitting in all of its pristine beauty atop my coffee table (by now my workbench was too small), it hit me. Somewhere between the initial concept and the designing of the fuselage, it had gotten away from me. Despite its short 60 in. wing, my Sea Fury was definitely not a Bearcat sized airplane.

I think the day I first flew the Sea Fury was perhaps the most pleasurable day that I have ever spent in modeling. When the airplane was ready, I picked a perfect spring day for the Sea Fury's initial flights. My wife, Linda, packed a picnic lunch while I loaded the car with two large cardboard cartons of miscellaneous spare parts, tools, camera equipment, etc. We set forth for a site in West Fort Worth, 35 miles away, where beautiful, smooth circles lay in a quiet, wooded, park-like atmosphere. After arriving, we first photographed the Sea Fury in both color and black and white (just in case). After running out the new 65 ft. .018 control lines, we pull-tested the airplane and lines, and were ready to fly.

What a thrill that first flight was! The sight of a Sea Fury out there on the end of the lines was terrific! Line tension, however, was only fair and seemed to disappear during maneuvering flight. The controls were so sluggish that round loops were difficult. When the engine cut, the glide was good and the Sea Fury settled gently onto its shock



Good morning, Fellow Modeller ...

I owe you! You were overcharged for your Firefly wing lights. I'd tried to pay for a big ad with one small item and that's not the way it's done.

So -- the new Paul Harvey Precision Prop Balancer is underpriced -- at 59 cents! Also you get a treatise by experts on the how and why of balancing a prop properly.

Also all of you who bought the Firefly lights kit will be receiving the prop balancer free.

P. S. Wait'll you see the most simple, most precise ever prop balancer! Plus the expert advice on prop balancing. Send one dollar for two and you have a neat gift for a friend.

Address:
Paul Harvey Products, Inc.
P. O. Box 77
River Forest, Illinois 60305

New

Model aircraft fabrication/ finishing products (Superior to Epoxy)



FABRA-TEX CORP.
P.O. Box 310
Waterville, Ohio 43566
Phone (419) 878-5646



All purpose two part contact glue. Has initial tack & variable set-time which you adjust(10 to 20 min.). Designed for balsa-wood, plywood & plastic. \$2.95



Extra light filler. Has variable set-time which you adjust(10 to 30 min.), sands like chalk in 30 min. & hardens in 24 hrs. Lighter than other fillers. \$2.95



Extra durable primer/ finish paint. Produces fast, light & strong finishes. Can be used as base coat under monokote or solofilm. Quarts \$4.99 Pints \$3.49

absorbing gear to end a highly satisfactory first flight.

I called to Linda for a sandwich and a Coke while I removed the wing. To correct the sluggishness of control, I changed the flap-elevator ratio from 30° flap - 30° elevator to 30° flap - 45° elevator, and added 1/2 oz. of tipweight to improve line tension.

On its second flight the Sea Fury was very responsive to control. Line tension, while improved, was still insufficient and it turned tighter inside than outside. To balance inside and outside turn rates, I removed the wing again to adjust the elevators downward slightly with neutral flap and more tipweight was added to further improve tension.

On the third flight the Sea Fury turned well, both inside and outside, and the general improvement in flying characteristics permitted closer evaluation of specific areas which needed improvement. For example, it was very light on the lines overhead and now that I had time to look, the Sea Fury was flying banked into the circle both upright and inverted. So that's why I had so little line tension! The Sea Fury was my first airplane built with exactly equal span inboard and outboard wing panels and the extra lift of the faster outboard wing was causing it to fly banked into the circle. While I had anticipated a need for adjustable tip-weight, I was surprised at the bank angle and a little unhappy when I saw that the tipweight box wasn't big enough. That

first night I had to settle for taping extra weight onto the outside of the outboard wing tip.

To adjust the tipweight, I added 1/2 oz. onto the tip each flight. With each addition of tipweight, the airplane flew flatter and line tension improved until, at three oz. total tipweight, the Sea Fury started "hinging" in the squares. With a reduction of 1/2 oz. of tipweight, the tendency to "hinge" was gone and the Sea Fury flew flat with good tension.

To improve the overhead tension, I moved the leadouts forward three times, in 1/4 in. increments until no further improvement in tension was noted and the Sea Fury was beginning to feel "doggy." Moving the leadouts back one 1/4 in. increment resulted in nearly optimum leadout location.

By this time it was beginning to get dark and time remained for only one final evaluation flight. This would be a full pattern flown at five feet except for the triangle and hourglass bottoms where I would pull out high and extra tight to evaluate the turning (lifting) capability. The Sea Fury flew beautifully except for a noticeable stalling tendency in the lower right triangle and hourglass corners. Well, I thought, you can't have everything, and all things considered, I was pretty proud of my 71 oz. airplane at this point.

That night I thought about the stalling tendency and decided that it might be improved if I could only hang the flaps out a little farther for more lift

M.E. DIESEL ENGINES

HERON .059 CU. IN.
\$14.95 P.P.

SNIFE .091 CU. IN.
\$15.95 P.P.

SNIFE R.C. - \$16.95 P.P.
SILENCER - \$4.45 P.P. EACH ENGINE

HOBBY HIDEAWAY DELAVAN, ILL. 61734



GOV'T. SURPLUS

MODEL 4 NICKEL-CADMIUM
BATTERY, 1.2 VOLTS

Rechargeable thousands of times



Sintered-plate alkaline storage battery displays flat voltage curve during discharge, has high discharge rate (up to 50 amps), holds charge for a long period of time. Spillproof, may be used in any position. Approx. 4 ampere-hour capacity. Dimensions: 6" high, 2" wide, 1/2" thick. Approx. weight: 6 oz. Uses potassium hydroxide (30% electrolyte).

Price \$2.50 each, postpaid

MODEL 7 N/C BATTERY, 1.2 VOLTS

Same general characteristics as battery above, but with 7 ampere-hour capacity. Dimensions: 4 1/2" high, 3/4" thick. Approx. weight: 9 oz.

Price \$3.50 each, postpaid

C & H SALES CO.

2176 East Colorado Street • Phone: 681-4925
Pasadena, California 91107

R/andy's Corner

R/C SUPPLIES

406 WEST WASHINGTON • HOPESTON • ILLINOIS • 60942

PHONE (217) 283-5710 AFTER 4:00 P.M.



C/L ENGINES: FOX .15-\$7.50, .25-\$9.50, .35, .36X-\$12.00, .36XBB-\$15.00, .40-\$13.25; ENYA .09-\$9.50, .15-\$11.00, .35-\$15.50, .45-\$25.00, .60-\$38.50; O.S. MAX .10-\$8.80, .15-\$11.00, .20-\$12.00, .25-\$13.00, .30, .35-\$14.00; K&B .15-\$19.50, .35 Stallion-\$9.50; COX .049 BB-\$4.50, 3/\$12.60, .049 GB-\$5.50, 3/\$15.00, Medallion .049-\$7.50, .09-\$9.10, .15-\$11.25, Tee Dee .010.051-\$9.10, TD .09-\$10.50; MIDWEST Panther, Cougar-\$11.50, Magician 15-\$7.00, Magician 35, Kingcobra, P-51 Mustang, Messerschmitt-\$10.00, 3/\$27.00; TOP FLITE Super Monokote 4-\$23.00, 12-\$60.00, 9 assorted trim sheets-\$5.67, Mustang, Quik Fli III-\$31.50, SE5A-\$33.60, P-40 Warhawk-\$35.00, 2/\$66.00, Contender-\$25.50, Headmaster-\$13.50, Top Dawg-\$12.50, Taurus-\$29.00, Tauri-\$19.50; MIDWEST Cardinal-\$16.50, Little Stik-\$16.50, Sky Squire-\$24.50, Tri-Squire-\$13.50, Esquire-\$12.25, Lil Esquire, Tri-Squire-\$10.00; STERLING Fledgling-\$19.00, 1-26-\$15.00, 1-34, Rimfire, Lancer-\$20.00, PT-17-\$33.60; JENSEN Ugly Stik-\$40.00, wing kit-\$15.25; BRIDI Kaos-\$39.50, wing kit-\$19.00, RCM Trainer-\$37.00; ROYAL B 25-\$56.50, P-38, Little Stinker-\$48.00, Cessna 310G-\$52.50, Spirit of St. Louis, Cessna 206-\$36.50, Cessna 182, Hein Sr.-\$40.00; AFI Malibu-\$18.50, Monterey, RF-4-\$22.00, high start-\$22.50; Windward-\$18.50; GRAUPNER Middle Stik-\$32.00, Cirrus-\$40.00, Cumulus-\$95.00; VK Cherokee, Navajo-\$28.00, Cherokee Babe-\$20.00, Mini-Flite Rivets-\$22.00; DREMEL Moto speed control-\$14.00, No. 271 complete-\$32.00, No. 281 complete-\$38.50, No. 572 complete-\$43.00; STAFFORD Commanche, Aircoupe-\$35.00, Sperry Messenger-\$32.00; Joy Mars-\$28.00, C-3-\$35.00; UNIVERSAL WHEELS 2 1/2-\$3.60, 2 1/4-\$3.75, 3-\$3.90, 3 1/4-\$4.05, 3 1/2-\$4.20, 3 3/4-\$4.35; HOBBYPOXY I-3/\$2.10, II-3/\$6.30, IV-3/\$4.20; AERO PREC. AT-6 Texan-\$26.00, Touchdown-\$16.75; A-Justo-Jig reg.-\$29.99, full house-\$38.00, fuse adapter-\$8.00.

ALL POSTPAID - INSURANCE ADD \$.30

TESTORS

Hobby Model Products

in the corners. To accomplish this, I changed the flap-elevator ratio to 30° flap—37° elevator. The change of ratio would definitely use more flap for any given rate of turn, but the extra flap would also reduce the effectiveness of the elevators making the airplane appear to turn sluggishly again. To compensate for the aerodynamically reduced sensitivity, I modified my small E-Z-Just handle for wider line spacing by cutting the plastic, moving the lines to the extreme top and bottom of the handle, and epoxying small pieces of plywood into the slots under the relocated lines. The next day's flying proved the combination of ratio change and handle modification did reduce the stalling tendency to the point that the triangle

and hourglass corners could be tightened normally with no sign of buffet and no apparent change of sensitivity.

When I tried flying the Sea Fury with its spinner, I found that it ran smooth and true but the nose cap would fly off each time the engine stopped. It seemed the precessional effects of high pitch rates were flexing the spinner backplate along the propeller axis where the backplate was weakened by the prop blade cutouts. This flexing would loosen the nose cap. After stiffening the backplate with a fitting machined by Bob Wilder, the problem was completely cured. In fact, considering spinner vibration problems that I have had on smaller airplanes, I am amazed at the rather unbelievable smoothness of this

very large spinner. (This flexing has since been corrected by Williams.)

To summarize the Sea Fury's flying characteristics at this point, overall I thought it flew very well and was definitely competitive. It turned as well as my Bearcat, but felt and looked much smoother due to the increased tail moment. Line tension was good except for the top of the vertical eight in wind over 12 knots. In a strong wind I would occasionally run out of elevator in the vertical eight as I started down from overhead. Also, the shock gear seemed to cause bouncy landings but that turned out to be a simple matter of improper location. Bending the gear back slightly fixed the landings completely.

Finally, however exciting, the Sea Fury was difficult to fly. It could fly any maneuver competitively, but only nine out of ten times. I found that no matter how much I practiced, I would usually bounce a corner or miss a pullout or an intersection on nearly every flight. Still, if I could put it together at the Nats, the combination of smooth corners, good shapes and impressive appearance could very well win.

At the '71 Nats, neither my flying or the Sea Fury's appearance seemed to make much impression on the judges in the first round of finals. I wound up "in the pack" in the mid 440s. In the second round, the Sea Fury nosed over on takeoff after being released downwind in a strong, gusty wind condition. All right, so an honest conventional gear

START THE SEASON OFF RIGHT!  <p>MIDWEST SWEET STICK O.S. 20 R/C ENGINE \$32.95 X-ACTO KNIFE CHEST \$21.50 SAVINGS OF \$15.40 VALUE \$59.40</p> <p>ALL FOR \$44.00</p>		PAL-Z ENGINE 19 TO 25 SHORT LANDING AND TAKE OFF ZENITH - ADVANCED TRAINER R. C. - 4-CHANNEL ENGINE 19 TO 25 HIGHLY MANEUVERABLE SHORT TAKE OFF SLOW LANDING SPEED JET APPEARANCE EASY CONSTRUCTION WILL FIT IN MOST JET CAR TRAYS ASSEMBLED PAL-Z R/C TRAINER, Balsa 19-25 ENGINES \$28.95 SPL. \$24.95 ZENITH - ADVANCED TRAINER 19-25 ENGINES \$29.95 SPL. \$25.50		 <p>DIGIT MIG 3 CHANNEL WITH ONE S-5 SERVO NICADS IN AIRBORNE PACK List \$119.98 INDY SPECIAL \$91.99</p>		 <p>BLUE MAX MARK II TC 6 Channel - 72 MHz or 27 MHz 4 S-5 Servos, Nicads, Charger Complete List \$339.95 INDY SPL. \$218.87</p>		 <p>DU-BRO Universal Muffler For all Engines except Webra's Size 29 thru 60 \$7.95 DU-BRO Webra Muffler For 40 thru 60 \$7.50</p>	
 <p>MINI-SHOP List \$36.98 Spl. \$33.00</p>		 <p>O.S. MAX MUFFLERS #701 - \$3.98 #702 - \$6.98 #703 - \$8.98 #704 - \$9.98</p>		 <p>PILOT BOX FLY PLASTIC & Balsa CONSTRUCTION HIGH WING ENGINE SIZE 19-25 List \$29.95 SPL. \$23.00 BOX FLY JR \$17.50 SPL. \$14.00</p>		 <p>SULLIVAN CONTROL LINES AND HANDLES Storage Reel \$1.00 Pro Handle \$1.20 Tatone Pro Handle \$1.75</p>		 <p>AMBROID SECURIT RESIN GLUE 8 oz. - \$2.00 4 oz. - 80c</p>	
 <p>Indy R/C SALES (317) 846-0766</p>		 <p>KRAFT HAYES ENGINE MOUNTS GLASS FILLED NYLON KM-05 \$1.99 KM-08 \$2.19 KM-15 \$2.29 KM-19 \$2.49 KM-19B \$2.49 KM-30 \$2.59 KM-40 \$2.79 KM-60A \$2.99 KM-60B \$2.99 KM-70 \$3.29</p>		 <p>ROCKET CITY ROCKET CITY RETRACT ARM WORLD ENG. SERV.</p>		 <p>SOLAR - FILM OPAQUES List \$6.60 Roll SPECIAL \$4.95 SOLVENT 65c Bottle</p>			
NORTH - 10538 Jessup Blvd., Indianapolis, Indiana 46280 • SOUTH - 2747 Brill Road, Indianapolis, Indiana 46225									
HOW TO ORDER: Send Check or Money Order for prompt delivery. Please include ZIP CODE. Indiana residents add 7% Sales Tax. Sorry, no C.O.D. orders.			POSTAGE, HANDLING & INSURANCE \$ 00 to \$10.00 \$.75 \$10.01 to \$50.00 \$ 1.50 \$100.01 to \$250.00 \$ 3.00 Over \$250.00 \$ 4.50 Postpaid						
NEW HOURS: 9:30 A.M. - 9:00 P.M. Mon. - Fri. Sat. 10:00 A.M. - 5:00 P.M.									

is still a competitive disadvantage, even with shocks. A month later, I found this type of takeoff accident could be prevented by launching into the wind. A 73 oz. airplane seldom becomes airborne accidentally.

I think most Nats stunt fliers were impressed by Gene Schaffer and his "Stunt Machine" performing in the wind. Gene's pattern seemed typical New York style except for his rather blinding corners. Chuck Hora thought Gene's corners looked as though the airplane had been "nailed," then "swiveled." While I also thought Gene's corners were unnecessarily tight, they were impressive and attention-gathering in their own right, and like beauty or semi-scale, served to attract the attention of the judges for "out of the pack" scores. I went home with the realization that the Sea Fury's corners should be further improved before Cleveland's FAI Finals to improve my chances of making the FAI team.

As a matter of fact, I had two problems to overcome. First, the Sea Fury left a heavy smoke trail which distracted the judged by drifting in the rounds and being blown to the ground by the flaps in the bottoms of the squares. This caused the Sea Fury to appear to bobble when, in fact, it hadn't. Since the ST 60 would tolerate much less oil than Superfuel's 29%, I mixed my own brew: 5% nitro, 20% Ucon oil, and 75% methanol. The smoke problem was cured, but the extra 9% combustibles increased the engine run from 6:15 to 7:00 which resulted in overruns in the FAI pattern. I decreased the run by enlarging the venturi from .305 to .315 ID. Burning the extra 9% combustibles in 6:15 instead of 7:00 released extra power from the engine which "perked up" the Sea Fury's performance all around.

Second, I began retrimming. I wanted to increase the crispness of my maneuvers by tightening all of the corners somewhat. To accomplish this, I added nose weight, knowing that more stability would result from a more forward CG location. Now more control deflection would be required to maneuver. The extra flap deflection increased lift again permitting sharper corners and a trouble-free vertical eight. Admittedly, it also took more deflec-

CANADIANS

Space Commander

We now have the new G-45 I.C. system in stock. Complete unit with four I.C. servos and all nickle cad. batteries. Three month warranty fast service and spare parts on hand. Only260.00
Complete line of Solarfilm Colours in stock.

New from Complete-a-Pac. Fairy Swordfish kit. 60" span engine up to .60. Complete kit includes plans, hardware, fiberglass cowl, pre-bent wires only .. 75.00
We also have the new 62" Zero

same as above 69.00
Plastic Fuselage formers for the
CAP Hurricane 7.95
Canopy for the CAP Hurricane 3.00
Plans for the CAP Hurricane 6.95
COWLING (fibreglass) for the

CAP Hurricane 6.95
Send \$1.00 for our 1972 85 page illustrated catalogue. This amount refunded on your first order over \$10.00.

Canadians only

CALGARY HOBBY SUPPLY LTD.

Box 3173 Stn. B. Calgary, Alberta.
118 40th Ave. N.W. Ph. 277-4664.
The model shop whose only business is Model Aircraft.

Top NATS Winners "C" Expert 3rd CONSECUTIVE YEAR

PRO LINE RETRACTS TOO!

1st RON CHIDGEY
Pro-Line
1971 & 72 Nats

3rd DON COLEMAN
Pro-Line
2nd 1971 Nats

2nd JIM WHITLEY
Pro-Line
1971 FAI Team

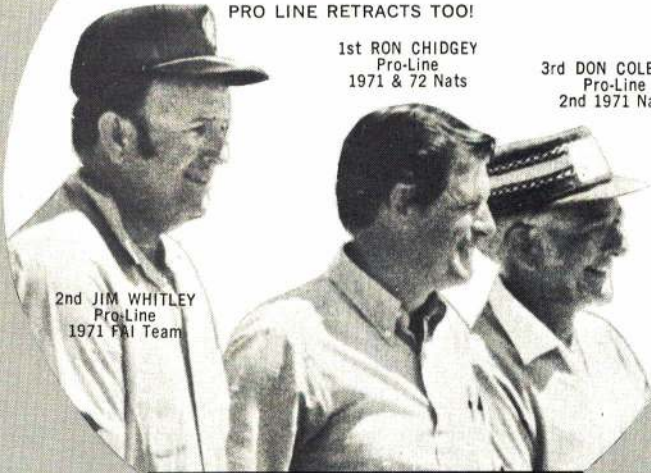

WRITE FOR OUR NEW 1973 CATALOG FREE!!

10632 N. 21ST. AVE., SUITE 10

PHOENIX, ARIZONA 85029

FIELDMASTER carry all



a rugged polyethylene double-walled carry all designed for the active modeler. 21"x10"x7".....

\$14.95

P-51 MUSTANG

1" scale CL kit....



pro-foam...THE ALL HOBBY FOAM!
WILL NOT MELT FROM GLUE OR DOPE. SHAPES AND SANDS LIKE WOOD. NO HOT WIRE NEEDED.

STANDARD SIZES AVAILABLE.

SAMPLE AND INFO. 50¢

\$12.95

Featuring.....
pre-shaped pro-foam wings,
fuselage... pre-cut ply and
balsa... formed gear...
silkspar covering.

for .15 to .30 engines

MMC

All products at your Dealer or order direct

10% shipping and handling, Illinois res. add 5% tax

MODEL MATERIALS COMPANY
119 MARIPOSA · WAUKEGAN, ILL. 60085

NEW FROM AERO PRECISION



ALL BALSA CONSTRUCTION

WINGSPAN: 53 INCHES
 AREA: 530 SQ. INCHES
 LENGTH: 42 INCHES
 ENGINE: 19-30
 WEIGHT: 3-4 LBS.

SEMI-SCALE PIPER VAGABOND

\$32.50

Designed by Bryce Petersen for three channel RC equipment. Kit features full-size plans, open cockpit construction, simplified building, photo-illustrated construction sheet, formed landing gear, bolt on wing, control horns, and hinges. All these are included in this one great kit.

AERO PRECISION • BOX 152 • TIPTON, INDIANA 46072

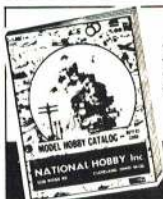

HOBBY CATALOG

78 Pages--8-1/2" x 11" size. Crammed with Airplanes, Rockets, Boats, Railroads, Cannons, Plastic Kits, Motors, Accessories, Supplies, Books, Tools, Etc., Etc., Etc.

SEND \$1.00 TODAY

REFUNDABLE ON FIRST PURCHASE

NATIONAL HOBBY, Inc.

5238 Ridge Road, Cleveland, Ohio 44129



BOX 26263 - Indianapolis, Ind. 46226

SCALE PLASTIC & BALSA MODEL AIRPLANE KITS

Frog - Airfix - Hasegawa - Gullow's - Kayeff
 Cleveland Kits, Plans & Printwood
 ACCESSORIES & MODELERS SUPPLIES

Imrie/Risley Paints

Badger Air-Brushes

MANY SPECIAL OFFERS

Send 25c for new 28-page catalog #MA-2A

Letraset Decals

Micro Scale Decals

LOWEST PRICES

We're worth traveling for!

NEW YORK

And you'll see why when you see our fabulous selection of leading hobby merchandise, all at low, low discount prices! We carry the top name brands in U/C and R/C equipment for your buying convenience. You'll be glad you traveled... when you see what's in store for you at our "one-stop" shopping centers for hobby merchandise. Centrally located for New York, New Jersey and Pennsylvania residents.

TINY TOTS

U.S. ROUTE 22, GREENBROOK, N.J. PHONE (201) 968-0440

U.S. ROUTE 35, MIDDLEBROOK SHOPPING CENTER, OAKHURST, N.J. PHONE (201) 493-2022

U.S. ROUTE 37 AT GARDEN STATE PKWY PHONE (201) 341-7000

All stores open daily 'til 9:30 - Sundays 10 to 5

TINY TOTS

PLAY & RECREATION ITEMS FOR EVERYONE

tion of the handle too, but I soon became used to it. The extra stability from the increased nose weight also cured the Sea Fury of being difficult to fly. It no longer had a mind of its own. It drove smooth and tight to crisp, accurate corners. At last the Sea Fury had arrived as an unlimited competition stunt ship. Five flights on that snarling, pulling, groovy son of a gun would spoil for anyone, forever, the put-put of a Fox 35.

On the day I was to leave for the FAI Finals, I ran out of fuel in cloverleaf on my last practice flight. Rather than accept a safe inverted landing with minimal damage, I "went for broke" again and tried to whip it through to save the airplane, undamaged, for Cleveland. It didn't work. Looking down at the mess, I knew my "go for broke" year had ended.

As far as I was concerned, the Sea Fury had proven itself a competition stunt ship even though it had never won a contest. Excepting Bob McKinney, no one had seen it fly well. Rather than let it end there, I decided to rebuild the old Sea Fury and to start immediately on a new Sea Fury incorporating improvements based upon experience gained from 303 flights on the original.

First, ground handling could be improved by shortening the landing gear a little to provide a flatter sitting attitude. The old gear had turned out over scale length anyway. Shortening the main gear 1/2 in. would actually improve upon scaleness. I would, of course, retain the shock absorbers as the guaranteed landings and visual effect were certainly worth the small extra weight.

Second, it seemed that slightly larger stabilizer and elevators would further improve the Sea Fury's "groove." Also, the larger elevators should allow changing the flap-elevator ratio of 30° flap-37° elevator used on the Sea Fury I, to 30° flap-30° elevator, thereby wringing more lift from the wing's available area. This would permit still tighter corners.

While designing the new stabilizer, it seemed a good idea to incorporate some "direct lift." "Direct lift" is simply rendering the elevators aerodynamically ineffective or insensitive around neutral. With "direct lift," small control handle inputs have little or no effect at the elevators but the accompanying small movements of the flaps cause the airplane to rise or descend smoothly, without any change of pitch attitude. By making most small flight path adjustments with the flaps only, the apparent smoothness of the flight is greatly improved.

There are several easy methods of obtaining "direct lift." The first, and most common, is simply to drill out the elevator pushrod bushing in the elevator horn to put "slop" in the elevators. Most fliers who use "slop" can move their elevators up or down about 3/16 in. at the trailing edge without moving the flaps, or, more properly, can move the flaps without moving the elevators. Another method used by World Champion Bill Werwage on his "Pacemaker" is to make the stab thicker than the elevators. Also, at one time or another,

RC fliers Phil Kraft, Jim Kirkland and Art Schroeder have related their experiences with stab types and generally agree that an airfoiled stab arrangement will have less elevator sensitivity around neutral than a flat stab setup. Since I practice 800 to 1000 flights each year, I already have problems enough with wear, so I decided to avoid "slop" and combine Bill's thick stab with as much airfoil as my construction method permits to obtain "direct lift" characteristics for the Sea Fury II.

Third, just in case the ratio change for increased lift was not quite enough by itself to obtain really outstanding corners, I would add one in. of span to each wing panel for a 4% increase in wing area.

Finally, I would try again to reduce weight, particularly in the tail. Because of the Sea Fury's unusual moments, a fraction of an oz. saved in the tail would be greatly magnified in the reduction of nose weight required. For example, the wing fillets were already molded from 1/16 in. sheet balsa but the Epoxolite fillets at the fin, stab and fuselage junction could be replaced with 1/32 in. balsa sheet fillets. A plastic hub Williams tail-wheel would replace the metal hub Perfect. Additional weight savings could be realized by skeletonizing the main gear platforms and spar webs. In addition to the normal hollowing of the wing tips and cowl ring, the rudder and elevator spars were hollowed as were the specially cut wing trailing edge pieces. I'm sure you get the idea. In fact the

Sea Fury II did weigh nearly two oz. less than the Sea Fury I. I had hoped for a greater savings. It looks like the larger wing and stab offset most of my additional effort.

The new Sea Fury and repairs to the old were begun simultaneously. The Sea Fury I needed a completely new forward fuselage assembly beginning just ahead of the cockpit. Molding the new fuselage half-shells fitted nicely with the molding of the new "II" fuselage shells and much time was saved by constructing duplicate bulkheads, firewalls, tank compartments, cooling air bypasses, cowl rings, etc. By the time the Sea Fury I's structure was repaired, the basic fuselage for the Sea Fury II was complete.

I'm certainly glad that I repaired the broken Sea Fury because work progressed slowly on Sea Fury II due mainly, I guess, to watching too much TV in my workshop. By the time I finished Sea Fury II on July 4th, I had been able to put in nearly 300 practice flights and two contest wins on the repaired Sea Fury I. Also, the repaired Sea Fury was used to break in several new and overhauled engines and at least 100 flights were made using Sea Fury II's tank, engine mounts, and muffler before Sea Fury II was finished.

The first flights on the new Sea Fury II eliminated any doubts about the value of my modifications for improved performance. The most noticeable difference was the Sea Fury II's ability to

HOBBY HELPERS FULL SIZE PLANS

Group Plan 465 3 oz. 60 cents

Jimmie Matters's record-breaking Lockheed Vega—modeled as control line beauty by Walter Musciano. Spans 50"; length 34"; for .45-size or similar power.

Simplified control line autogiro—designed by Ole Dan Nielsen. Rotor diameter 34"; length 37"; takes .45 to .65 size engine with motor control.

Group Plan 966 6 oz. \$1.10

Lockheed Lightning P-38. Semi-scale stunt control-line model by Lew McFarland, uses twin .19's with throttle control for shooting landings.

Thorp Tiger. Famous home-built aircraft in radio control model form by Jess Kriesser. Takes a .35 engine.

Group Plan #953C 1 oz. 45¢

Focke-Wulf FW 190 German World War II control line flying scale fighter model by Walter Musciano. 3/4" to 1" scale; takes engine from .14 to .29 cu. in.

A/2 Viking Nordic Towline Glider by British Champ Bill Farrance. These are HALF-SIZE plans with full size ribs and cross sections.

Group Plan #166 6 oz. \$1.10

"Interceptor Five" by Harold deBolt. Latest in famous designer's series of outstanding R/C Multi Class planes. Spans 67½ inches; 50 inches long; uses .61 size engine.

For Special Handling of Plans only	8¢ per oz. 1st Class	Latest Catalog send 15¢ to cover handling
	11¢ per oz. Air Mail United States and Possessions only	

HOBBY HELPERS
1543 STILLWELL AVE. • BRONX, N.Y. 10461

FIRST PLACE WINNER
Best Original Design and Most Outstanding Finish. 18th Annual Toledo Conference.

DARIO BRISIGHELLA SR. says:
I've tried the many newer finishes including the film-type coverings, but
FOR MY COMPETITION MODELS, THE ONLY WAY TO GO IS AERO GLOSS DOPE

Winning best finish awards with offbeat combinations of Aero Gloss has become a habit with Dario Brisighella Sr. of Oak Creek, Wis. His latest: A "plum-crazy" combination using his own specially blended "international orange," "rich plum," and "ice white," with jet black striping on the widely publicized "VIPER." "It may be that I just think of models and Aero Gloss together," Mr. Brisighella says, "but in thirty years I've never gotten a bad job using it." Which is not such a bad reason to consider Aero Gloss for your next competition model.

Other reasons:

PRE-FORMULATED AND READY TO USE—For dependability, for convenience!

40 DISTINCTIVE COLORS—Providing an unlimited color range for the unique and trend-creating color concepts that contest judges are always looking for.

TOUCH-UPS AND ADDITIONS NO PROBLEM. With Aero Gloss, another matching jar is always available. Leftover paint or mix can be used again.

INNOVATE, BLEND, CAMOUFLAGE! The exclusive Aero Gloss formula comes in military flats, fluorescents, candies, metallics and in spray and brush-on dope.

AT YOUR HOBBY DEALER IN SIZES FROM 1 OZ. TO 1 GAL.



Announcing "Royal Super Sport 1"

FEATURES

Full 6 Ch. Proportional Control
 Super Smooth Closed Face Dual Sticks
 Transmitter Case — Silver Color
 Vinyl-Brushed Aluminum Finish
 Aux. Controls (5th & 6th Ch.) are
 Fully Proportional
 Choice of frequency: 72.08, 72.16 72.24,
 72.32, 72.40, 72.96, 75.64
 Receiver — Same Proven Circuitry
 Used in 70 Series Classic
 Servo — IC Amplifier — 3 Wire
 System. RS-4 Mechanics
 Battery Pack — 475F

Introductory price \$309.95

royal

Electronics Corp.
 2119 So. Hudson St.
 Denver, Colo. 80222

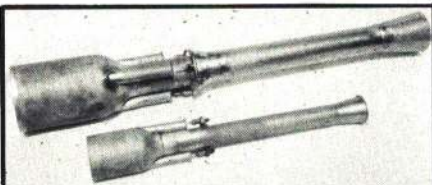
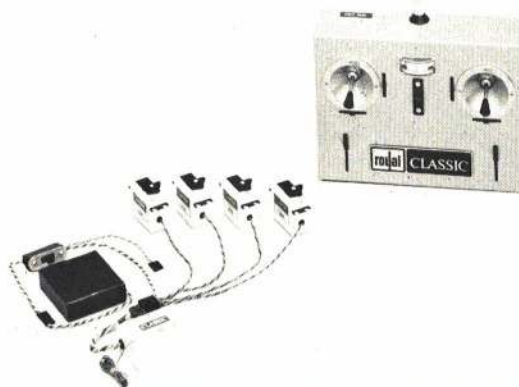

Small jet engines for Model Aircraft . . .
 Boats . . . Race Cars . . . Experimenters.
 Operates on propane fuel. No rotating or
 vibrating parts. Throttleable between 50%
 and 100% power.

THERMO-JET
 BOX 1528 KERRVILLE, TEXAS 78028
 (512) 367-2148

turn in the lower right triangle and hourglass corners. With the Sea Fury II there is no buffeting in those corners no matter how hard you hit them. Corner radius everywhere is now limited only by reaction time, smoothness and practice. The new Sea Fury II is so much improved over the Sea Fury I that my next building project is larger stab and elevators for the old Sea Fury to improve its "groove" and permit the ratio change for more lift. If this doesn't produce approximately identical performance to the Sea Fury II, I'll build a new wing with the extra two-in. span. The Sea Furys will then be structurally identically. A rework of the cockpit and a new paint job will complete the transformation.

My final change to improve the overall appearance of the Sea Fury's pattern was to increase the control-line

length from 65 ft. to 70 ft. People have remarked before that a large airplane like the Sea Fury tends to look cramped for space while maneuvering on my old lines. With the new, longer lines this cramped appearance was completely eliminated. Now people complain about the size of my maneuvers. Anyway, the net effect was definitely beneficial so the Sea Fury II was trimmed to fly best on the longer lines.

I did notice one curious effect of flying on longer lines. To maintain the necessary five sec. lap time for a 6:30 pattern, I had to lean the engine slightly. The leaner mixture brought unexpected fuel economy and my engine run went up to 8:00. Further enlarging the venturi led to instability of my run, so instead, I shortened the duration to 6:30 by increasing the nitro content of my fuel to 10%.

Looking forward to summer fun?

we'll look into a free flight helicopter



What you'll see is a little model that thrives on clean air, open spaces, and the exhilaration of flying free. Designed as a semi-scale of the Enstrom F-28A

Specifications:
 Main rotor dia. 32"
 Engine .049 to .051
 Weight 20 oz.
 Fuselage length 24"

Features:
 Belt driven rotor shaft.
 Fully formed, joined and painted FiberGlass fuselage.
 Machined, Molded and Pre formed parts.
 Detailed plans and instructions.

and powered by an .049 engine, the model is capable of flying to a height of 500 ft. and autorotating slowly back to earth when the tank is dry.

It's a lot of fun for a low price: yours for under \$40.00

Send for fully illustrated descriptive literature.

Catalog and Model Helicopter News magazine \$1.00.



BROZ ENTERPRISES, INC.
 104 Lake Scranton Rd., Scranton, Pa. 18505

SUPPORT AEROSPACE EDUCATION

By working a less desirable schedule and losing a lot of sleep to early morning practice, I was able to get 150 flights on the Sea Fury II before leaving for the 1972 Nats in Chicago and another 45 flights in Chicago before Open finals. With a good airplane and a luck draw in flying order, my Sea Fury and I were able to pull off a win in Open Stunt. This was particularly satisfying as a few short years ago separate Stunt events were sometimes held for semi-scale stunt ships because of their supposed inability to compete effectively with "classic" stunt ships. This year, realistic semi-scale stunt ships took first, third and fourth in Open Stunt and first in Senior Stunt. Maybe now I've heard the last of those cracks about semi-scale scale ships.

Let me end with a precaution. It has been demonstrated that realistic semi-scale airplanes can compete effectively with classic stunters, but—they are heavily compromised. With less than optimum moments, shapes and wing locations, and with a significant tendency to build overweight because of greater bulk and larger surface areas to paint, you start out with two strikes against you in competition. Add to the requirement for up to three times greater construction time, and it becomes obvious that realistic semi-scale projects should not be lightly undertaken. To design a realistic semi-scale stunt ship you must somehow overcome its disadvantages in layout and bulk. To do this you will surely need to use unique construction techniques, extra built-in trimming capability, up-to-date aerodynamics and clever or creative ideas and concepts. If you are clever or lucky enough to come up with a truly competitive design, you still have to practice as much as the other top fliers to develop the necessary flying skills to win. In other words, think about it.

FREE! New Fun-Filled 1600 UNUSUAL ITEMS

Funmakers•Hobbies•Sports•Games•Imports
Jewelry•Emblems•Patches•Psychodelia
Science•Electronics•Photo•Optics
Jokes•Magic•Gifts•Gadgets



Which Things Listed Below Would YOU Like?

No Other Catalog Like It Anywhere!

FREE CATALOG!
Johnson Smith Co. Dept. XXX
Mt. Clemens, Mich. 48043

Answers to Your Questions about this Free Catalog
Why is it Free? Read it for fun and entertainment, but it pays us to send it to you. Free because most people find things they want and order them. Is there any obligation? Absolutely none! Are there things to interest me? Yes! We think you'll find plenty to amuse and amaze you. Every item guaranteed. No other catalog like it.
Johnson Smith Co., Dept. 0000, Mt. Clemens, Michigan 48043

E-Z JUST CONTROL HANDLES

"Hot-Rock". Ideal for everything from 1/4 A's to speed. Pre-formed loops for quick hook-up. Pull-tested for 150 lbs. min. Hot fuel-resistant plastic handle. 4" size.
\$1.50

E-Z-JUST TEST STANDS.
Quick, sure lock-up for any engine..... \$2.75
At All Leading Dealers

PHIL-LEYS
BUFFALO 25, N. Y.

BIG DADDY 88 RC 88 KIT \$89.50
LITTLE BIG DADDY 66 RC 66 KIT \$59.50

WING SPAN 88 IN. WING SPAN 66 IN.

QUALITY COUNTS... WE HAVE IT!

- *ORIGINAL DESIGN
- EASY TO BUILD AND FLY
- TAKES REGULAR 3 OR 4 CHANNEL RADIO
- KIT SANDED AND MACHINE CUT
- COMPLETE EASY TO FOLLOW ASSEMBLY
- KIT INCLUDES ALL HARDWARE, WHEELS ENGINE MOUNT

Write For Free Brochure
TEXAS
MODELS UNLIMITED
1623 DUMAS DRIVE
AMARILLO, TEXAS 79107
AC 806 383-1301

S/B

SANTA BARBARA ONE DESIGN. More than five hundred sold — and #10 can still beat #500! Length 70 in., mast 72 in., sail area 1100 sq. in., displacement 28 lb. Prefinished fiberglass hull, deck, cabin and keel \$165.00

u

SOLING-M. Scaled from the exciting new Olympic-class three-man keel boat. Length 50 in., mast 60 in., sail area 800 sq. in., displacement 18 lb. For American Model Yachting Association 50/800 "M" class racing. Prefinished fiberglass hull and deck, machined cast-iron keel \$125.00

BOTH KITS include finished Dacron® sails, spruce spar blanks, stainless rigging, brass fittings, and die-cast aluminum rudder. For two- or three-channel r/c operation with the Vortex sail control unit.



SEE YOUR
HOBBY DEALER!

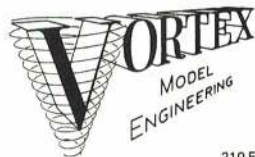

210 East Ortega Street
Santa Barbara, CA 93101
Telephone (805) 963-1636



SAIL CONTROL UNIT with gel/cell® battery and charger \$75.00

JOHN BLUM*(Continued from page 41)*

The throttle linkage is held in the high-speed position by the triggering system. When the system is actuated, the spring pulls the lever from position C (high speed) to position D (low speed). The lever comes to rest on the stop, which is adjustable for pre-flight slow speed correction. As the foregoing takes place, the throttle rod simultaneously moves from position A to position B, the sliding tube allowing the elevator pushrod to move freely back and forth through the tube.

The transition from high speed to this point is not unlike any other system except the actual throttle movement is sudden and not gradual as with the three-line system. Now comes the burper. The model will assume, through elevator control, a slight nose up attitude in slow-speed flight. This is the position of bellcrank, elevator pushrod, along with throttle linkage and rod, in the sketch.

The system is designed so that sudden snapping of up-elevator, which won't disturb the model noticeably in slow flight, will actuate the linkage to open the throttle momentarily. On slow speed the throttle rod is at position B. When the up-elevator is snapped, the washer, soldered to the pushrod, moves against the sliding throttle rod and opens the throttle. This will allow the engine to kick out the excess fuel. Several short bursts will allow a correction in flight attitude.

This basically is how it works. There are



Mauler making deck approach at Arizona contest. Ron Duly of Burbank, Calif. Note tail-hook down.



Bill Dean's

\$6⁹⁵ Kit #S-5

CESSNA "170"

More than a dozen contest wins to its credit. A detailed scale replica of the prototype, easily built from a well detailed set of plans. Fly with or without R/C Plastic cowl; die-cut balsa and ply parts; selected strip; gear formed; celluloid; decal set; shaped, tapered wing edges.

Free-Flight020 to .045



\$6⁹⁵

Kit #S-6

PIPER SUPER CRUISER

All the scale realism you could hope for. The look, the feel, the performance of the full scale "Super Cruiser". Fly it with or without radio. Highly detailed plans, an attractive decal sheet; plastic cowl; formed gear. The balsa and ply parts are die-cut. Dowel; wire; covering.

Jetco RADIO SCALE AIRCRAFT

FREE-FLIGHT, RADIO CONTROL
Radio Control045 to .074



16" Wingspan **\$1¹⁹** Kit #J-2

"CUTLASS"

For Jetex "50" PowerCatapult . . .



22" Wingspan

\$1¹⁹

Kit #J-3

"JET 50"

Fly it today. It assembles that fast!!! High thrust prevents looping; die-cuts; clay ballast; hardwood fuselage. Flys!

VINTAGE R-C PLANS

NEW!!

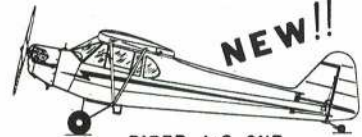

PIPER J-3 CUB

9 FT. Wing Span — DESIGNED BY - R.C. SWEITZER
(IDEAL FOR ROSS "TWIN" OR "FOUR")

3 SHEETS 36"x72" Plans: \$10.95
SEND 25¢ FOR NEW 1973 CATALOG TODAY!! NOW!!

— 27 GREAT NEW VINTAGE PLANS —
— PLUS MANY OTHERS —

DEALERS INQUIRIES INVITED

SID MORGAN

13157 Ormond, Belleville, Mich. 48111

BEST IN KIT DESIGN

Jetco

See your dealer today for these and other fine Jetco kits of all types. If no dealer is convenient, send us \$0¢ additional, and mail orders will be filled direct.

C. A. ZAIC CO. INC., 883 LEXINGTON AVENUE, BROOKLYN, NEW YORK 11221



CLEVELAND MODELS

PLANS "STILL BEST BY FAR"
SAY EXPERIENCED MODELERS
THEY MAY BE BEST FOR YOU TOO!

If you love the old vintage aircraft as our volunteers do, you'll really love many dozens of the tremendous variety we offer, even if they do not all appeal to you. They're designed with the meticulous care and detail which only dedication and labor of love can create as you'll find out when you order some.

JUMBO SCALE BUFFS-HAVE WE GOT 'EM!

We're bringing back the old era of C-D modeling with plans of those famous old beauties like the Great Lakes, Curtiss Hawk, F11C2, See-See, Roscoe Turner's and Jimmie Weddell's W-Wins., Laird Solution, TA Mystery Ship, Pesco, Caudron, Folkert's, Benny Howard's Pete, Ike and Mulligan, etc., in all for scales—1/8", 1/4", 1/2", 3/4" and 1 1/2". New P.S. pattern drawings are available for all newly issued "oldies."

Collectors too, find great enjoyment in spending many enjoyable nights just pouring over the plans, building them in their minds, they tell us, when they can't actively build.

CATALOG SEND 60¢ TODAY—2 YEARS \$1.10
DEDUCT 10¢ IF YOU SEND COIN OR CURRENCY
EXTRA CATALOG COPIES NOW 50¢ EACH
CLEVELAND MODEL & SUPPLY CO.
103078 Detroit Since 1919 Cleveland, Ohio 44102



YOUR AMA NUMBER PRINTED ON 25th ANNIVERSARY NATS SHIRT



**Official Commemorative Two Color Insignia
AMA Number in LARGE 2" Characters
Contrasting Blue Trim
Sizes: Mens - S,M&L -Youth-M,L&XL
\$3.50 plus 50¢ postage per shirt
Send size & AMA number to:
Fagel Brothers - Suite 2401
3930 Pine Grove
Chicago, ILL. 60613**

more sophisticated systems. Of particular note here is the difficulty in adjusting the position of the washer. It must be positioned to actuate the rod only at extreme up-elevator. It can't be positioned so that the rod rests against the washer on slow speed nor can it be too far from the rod. Multiple mechanisms will answer this need. There are complications and many reservations to the system. It depends on the price one is willing to pay for the suspected mph advantage.

Appearance Points Again: An aged discussion in Stunt to say the least. Jim Fasimpar (Tolono, Illinois) produces the thoughts as to just what percentage of the total score this is and is it all that important. To this end we will add more thoughts.

Utopia in a final Stunt score is 670 points. That's the ultimate possible points available. Since nothing is perfect, then resulting scores are something less than this. See page 35 of the AMA Rulebook. Of the 670 points, 40 is possible for the creative work, commonly referred to as the appearance points, five points for start in one minute and 25 points for doing all of the maneuvers in the proper sequence. Each maneuver has a maximum pos-



Goodyear stunter with O.S. 35 power from Nobler kit by Mark Bauer of Norridge, Ill.

**GEORGE ALDRICH
MODEL PRODUCTS**
3219 SHADY SPRINGS RD, SAN ANTONIO, TEXAS 78230
512-342-6495



- GMA CUSTOM ENGINES FOR ALL EVENTS, THE BEST IN MODELING.
- ABC ENGINES A SPECIALTY—UNIQUE HEAT TREATING & HONING PROCESS, A PROVEN NATIONAL WINNER!
- FULL TUNING & REWORK, CUSTOM MACHINING.
- FULLY TUNED PIPE, MINI-PIPE, OR MEGA-PHONE SYSTEMS.
- CUSTOM WATER JACKETS FOR BOATS.
- FACTORY RECOGNIZED REPAIR & REWORK ON HP ENGINES.
- PROP PITCH GAUGES, GEARED MONOLINE HANDLES, SPEED SUPPLIES
—SEND 25 CENTS FOR PRICE LIST.
- ALDRICH CUSTOM COMBAT PROPS AVAILABLE NOW! 9x6, 6 1/2-7-75 CENTS EACH.

NAT'L. CHAMPIONS USE GMA CUSTOM ENGINES:
TERRY PRATHER, BRIAN WEBSTER,
HENRY SPENCE, KERRY FREEMAN,
1st C.L. G.Y. JR. SR. & OPEN
"IF THE CUSTOMER ISN'T HAPPY—I'M NOT!"

SUNDAY FLYING

40-SIZE

Fly 'em Retract Or Fixed Gear

A-6 INTRUDER CUTLAS PHOENIX V

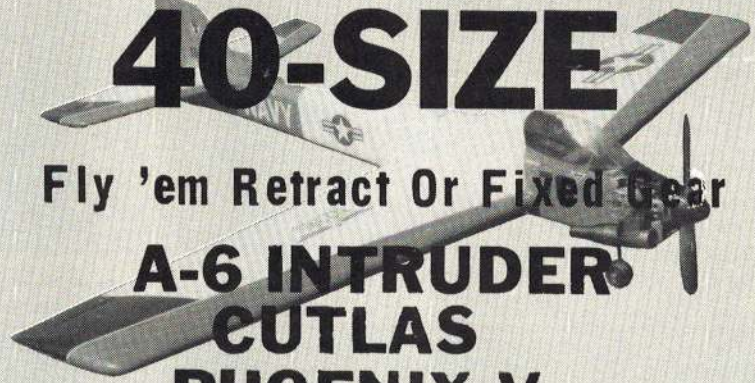

Fiberglass fuselage and vertical fin. Bulkheads and maple engine mounts are installed. Foam wing and stab included in kit.

\$42⁹⁵

DEALERS—Tired of long back orders? Try us—get your special price list. These kits carry full dealer discount.

1/4 Midgets

- ★ Minnow
- ★ P-51
- ★ P-63 King Cobra

\$34⁹⁵

Pattern Planes

- ★ Daddy Rabbit
- ★ A-6 Intruder
- ★ Phoenix V

\$49⁹⁵



ORDER TODAY! Make a list of what you need and write or call for confidential price list. We've got fast service . . . save the Bob Reuther way!

BOB REUTHER'S HOBBY WORLD

6602 HIGHWAY 100 DEPT. A
NASHVILLE, TENNESSEE 37205, U.S.A.
24 HOURS: DAY (615) 356-1225
NIGHT (615) 352-1450

**TENNESSEE'S
LARGEST
SHOP**

**FOR THE ULTIMATE IN SCALE
THINK AEROTEC**

German WWI Fighter

ALBATROS D-5A

2" to 1' Scale—58-1/4" Span—.60 Disp.



A Custom Crafted Kit only \$89.95

French WW I Fighter

SPAD—XIII

2" to 1' Scale—53-7/16" Span—.60 Disp.



A Custom Crafted Kit only \$69.95

Plans only,	W/Rib & Formers
Albatros D-5A \$9.95\$31.95
SPAD-XIII ..\$9.95\$29.95
Fokker DR-1 \$8.95\$29.95
Eindecker ..\$8.95\$27.95
Boeing P25-A \$9.95\$31.95

All above 2" to 1' Scale

Triad Kit with 2 wings\$49.95
DR 1 Triplane 3" to 1' Scale Plans	\$14.95
3" to 1' scale DR-1 full kit\$135.00
Ribs and Formers and Plans for	
DR-1 3" scale\$38.95
Special engine & 3 inch accessories	available—send 10 cents for catalog.

AEROTEC MODEL ENGINEERING, INC.
Box 116, Lincolnale, N.Y. 10540
(Dealer Inquiries Invited)

sible score of 40. On the basis of perfect, out of each flight 70 points is possible on the ground or 10.5% of the 670 points. This leaves 89.5% of the maximum to be earned in the air. Some refinement shows that appearance can account for 40 max. points or 6% of an ultimate flight. If we ignore the 30 points for equipment efficiency and memory, appearance points increases to 6.2% of total possible.

For discussion let's say a good flier averages 32 flights (15 maneuvers) points plus 36 for appearance totalling 516 points? The average flier makes 420 in the air and 28 for the artwork totalling 448. The difference and conclusions are obvious: (1) 68 points difference in total; (2) Eight points difference in appearance portion. It's still a flying game since the elimination of appearance points in our case example of eight points is only 1.8% of the score of 448. A 60-point difference still remains. Thusly, with or without the appearance points, the fellow who practices with average equipment will be ahead.

Take Part: Send photos and info on Carrier and Stunt to John Blum, 2417 Glen Pl., Granite City, Ill. 62040.



P-40 stunter by Bill Noyes of Valinda, Calif. McCoy 40, three-blade prop, muffler.

**SALES UP — PRICES DOWN
Now \$79.50
Hi-Lo Super Deluxe Kit**

George Hill, active contest flier,
co-designer of Hi-Lo,
co-owner of Airborne Associates.



Kit includes beautiful fiberglass fuselage, engine mounts, firewall, bulkheads all installed. Glaskin wing and stab, all balsa pre-cut to shape; instructions. Retractable cutouts fit most units. Orders must specify engine upright (recommended) or side-mounted, fixed or retract gear.

ATTENTION Class A & B Pattern flyers: here's a great opportunity — win 1st place flying your Hi-Lo in any AMA-sanctioned contest during 1973 and we will send you \$20.00 or a \$20.00 credit on any of our kits. Offer limited to one win per person. Send small photo of yourself with Hi-Lo and note from CD verifying your win.

Dealer inquiries invited

Airborne Associates
4106 Breezewood Lane, Annandale, Va. 22003

THE HEN OR THE EGG— which came first?

THAT'S OUR PROBLEM TOO! WE'VE GOT THREE OF THE BEST PUBLICATIONS ON THE MARKET FOR R/C TODAY. BUT WHICH ONE SHOULD YOU BUY FIRST? READ ABOUT ALL THREE AND THEN YOU DECIDE. WE THINK THAT YOU WILL BE IN THE SAME DILEMA — WHICH COMES FIRST?

**GETTING STARTED
IN RC**

by Howard McEntee

Howard McEntee, the acknowledged leader in RC, wrote this nineteen chapter instruction manual to help the beginner as well as the experienced RCer. Everything related to RC is analyzed in easy-to-understand terms. RC is becoming the modeling technique whether it be planes, boats, or cars. This book is for all these applications. There are other manuals on the market but this is the best one available. It is a must for both the experienced and beginner.

\$1.25

**1973 RC PRODUCTS
DIRECTORY**

by The Staff

It could drive you mad trying to accumulate all the information on RC products available. There are too many manufacturers for you to be able to evaluate all their products. The **RC PRODUCTS DIRECTORY** offers a unique advantage. Each entry has pictures, clear descriptions, specifications, and retail prices. This is not a discount catalog. There are 27 categories in this 112 page directory including planes, boats, cars, engines, radios, hardware, landing gear, etc.

\$2.25

**GETTING STARTED
IN RC CAR RACING**

by George Siposs

The newest in our library series, this book covers everything there is to know about RC Car Racing. Engines, chassis and drive systems, body, learning to drive, forming clubs and competitions, are just a few of the things discussed in great detail. Most important, it is written in language that a beginner can understand. If you are thinking of getting into car racing, or if you are already there, this is the most up-to-date instruction manual for you.

\$1.25

MOONEY ON FF

(Continued from page 65)

with its propeller in the middle of the fuselage. The model was superb and the propeller revolved just like it was supposed to, but Joe's devotion to scale prevented even a dihedral addition and the model could not be qualified even though it took off many times. It was close, but no cigar!

Meanwhile back at the contest they were flying the other events. Peanut Scale was the most popular with 21 Open and eight Junior entries. Clarence Mather's Jodel Mascaret took first as usual in Open. So far the rest of the contestants haven't been lucky enough to have that Jodel fly out of sight, but it came close a couple of times. John Nowak took



CO-2 powered Auster by Britisher Pete Redhead.

Bill Hannan's Szekely "Flying Dutchman" and Druine Turbulent.

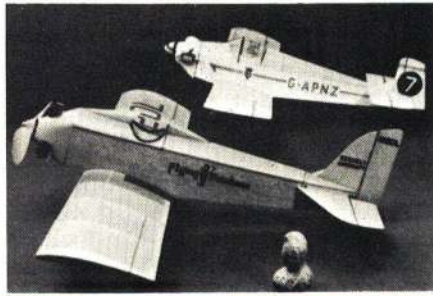

THE "CLEAN" MACHINE

THE ALPHA POWER UNIT-Electric Propulsion System for Model Planes

- Clean, quiet, always starts
- Flies many Kit planes, not just one
Up to 1.5 lbs., up to 100 inch span
- Flight tested on both R.C. and free flight planes
- Money back guarantee on quality and performance
- Light weight-6.5 ounces • Quick recharge-20 mins.
• Long run-8 mins.

PRICE ONLY \$45.50 including Recharger Completely Assembled.

ALPHA TIMER-Pushbutton control for free flight

Price \$14.95 completely assembled

MO CONTROL R.C. MOTOR CONTROLLER-Two channel control from a single channel Price \$12.95 assembled

THE ALPHA POWER UNIT



Shown with 10" prop., precision motor and gearing, rechargeable NICAD battery. Overnight Charger also included

GALLER ELECTRONIC INDUSTRIES
P.O. Box 87, South Walpole, Mass. 02071

Send for free brochure and plane plans. Dealer inquiries invited.

European

CARD MODELS

PLANES, SHIPS, ARCHITECTURE; IN FULLY COLORED, THREE DIMENSIONAL, CUT OUT AND ASSEMBLE SCALE MODELS FROM PAPER. THESE DETAILED CONSTRUCTIONS SUPPLIED AS PRINTED SHEETS, CODED LINES, PLUS A "METHOD SHEET" IN ENGLISH, SUPPLEMENT FOREIGN LANGUAGE INSTRUCTIONS TO PROVIDE NECESSARY DIRECTIONS.

The JUMBOS
7-1463 DORNIER DO-X (1:100) \$1.94
7-1823 BOEING 747 (1:50) \$3.15

SIX MILITARY PLANES (FIVE TYPES)
(1:50) \$4.08

special
Large Transports (1:50)
7-933 DC-7C 36" SPAN \$1.80 (\$3.30 Reg.)
7-989 CONSTELLATION \$1.80 (\$3.30 Reg.)
7-900 ELECTRA \$1.30 (\$2.30 Reg.)

Foreign Orders California Residents
Postal Money Order or 5% Sales Tax
Bank Check, collectable in U.S. Funds without charge NO C. O. D.

ONLY IN CARD
#1204 SCHARNHORST 37" \$4.75
#1203 LEIPZIG 27.8" \$3.10
#1205 KARLSRUHE 26.4" \$3.10
#1210 LUTZOW 30" \$2.75
#1021 ONASSIS' CHRISTINA 15" \$1.25
7-1893 \$4.25
D-LZ 127 GRAF ZEPPELIN 1:200 FOUR FEET LONG

(WATERLINE 1:250)
SHIPPING CHARGE
\$.35 (UNDER \$2.50)
\$.50 (TO \$4.99)
\$1.00 (TO \$9.99)
*\$1.35 (\$10.00 & OVER)
*Calif. \$1.10

Catalog \$.25 (Free With Order)
JOHN HATHAWAY
410 W. 6th St/Box 1287
San Pedro, Calif. 90731

WHY NOT ALL THREE

Instead of buying each publication separately and spending **\$4.75**, buy all three for only **\$4.00!**

or

The 1973 RC PRODUCTS DIRECTORY and one book for only **\$3.00!**

POTOMAC AVIATION PUBLICATIONS, INC.
733 FIFTEENTH STREET, NORTHWEST WASHINGTON, D. C. 20005

ALL THREE @ \$4.00
 RC PRODUCTS DIRECTORY AND
GETTING STARTED IN RC \$3.00
 GETTING STARTED IN RC
 RC PRODUCTS DIRECTORY
GETTING STARTED IN RC CAR RACING

NAME _____
ADDRESS _____
CITY _____
STATE _____
ZIP _____

THINK ABOUT IT

FOREIGN ORDERS MUST BE ACCOMPANIED BY AN ADDITIONAL 25%

REPLICA OLD TIMERS
.020 POWERED
AUTHENTIC SCALING - MACHINE CUT PARTS
FREE FLIGHT or RUDDER ONLY R/C



Megow 1940 Ranger
2:3 Scale 30" Span
\$8.95



Scientific 1940 Mercury
1:2 Scale 36" Span
\$7.95



Berkeley 1937 Buccaneer
2:5 Scale 36" Span
\$8.95

1941 Ehling Request \$6.95 / 1937 Miss America \$8.95 / 1940 Clipper Mk II \$8.95

MICRO MODELS
P. O. BOX 1273
COVINA, CALIF. 91722

Standard terms to Dealers and Distributors.
Mail orders: See your Dealer first. Add 75c
per Kit for postage and handling. Cal. residents
add 5% sales tax.

first in Junior with a Nesmith Couger that was really flying well.

Entries were 18 and three in Rubber and C. Mather took it in Open and David Albert took first in Junior with a Bede BD-4.

Bill Warner took first out of 11 entries in FF Gas Scale with his Nationals-winning Waco YKS6 and first out of eight entries in CO-2 scale with his Eastbourne Mono.

If one thing can be said about the winners at the Flightmaster's Annual Scale contest, it is that they all fly well-tested models.

After the prizes were awarded, everyone got to select a piece of merchandise. Bill (Harold) Warner entertained the crowd with his guitar singing a Scale song about the many Scale personalities he has known. That put the cap on a perfect day.

Interesting Models: Pete Redhead of England has built a nice model of the Auster powered by a Brown Junior CO-2 motor. The photograph was forwarded by Bill Hannan, of "Plans and Things," who also has built a couple of really nice new Peanuts—a Druine Turbulent and a Szekely "Flying Dutchman." Another interesting model using Hungerford wheels is the Stahlwerk Mark III b. Fulton Hungerford's wheels make all the difference on one of these simple oldtimers.



72 Series Hirtenberger Engines

The most powerful muffler equipped R/C engines in the world!

HP40F-RC

Ideal pattern engine
Excellent idle
.90 horsepower

\$56⁹⁵
(with muffler)



HP40R-PR

Perfect for RC pylon
Dependable power
1.2 horsepower

\$59⁹⁵
(with RC
mixture venturi)

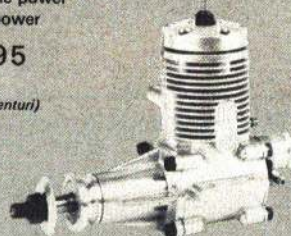

HP61FR-RC

Pattern and scale leader
Brute power
1.3 horsepower

\$84⁹⁵
(with muffler)

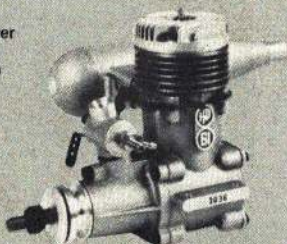

HP61RR-RC

Open pylon and marine use
All new disk rotary valve
1.52 horsepower

\$92⁹⁵
(Marine version
\$102.95)



HP ENGINES...THE NEW BREED!

Muffler as part of integral design
World Championship performance with handling qualities so gentle they are ideal for sport flying
Schneurle ported for competition power
Lowest vibration of any high powered 61
Coolest running of any 61 engine
Old World craftsmanship and care throughout

ALL HP PARTS CARRIED IN STOCK-IMPORTED BY



NELSON MODEL PRODUCTS

6929 WEST 59TH STREET • CHICAGO, ILLINOIS 60638 • (312) 586-7101

MODELER MAIL

(Continued from page 8)

at present, the "underdogs" in the model aviation field.

Again allow me to state that I mean this not as a criticism of AAM, but merely as a suggestion in keeping with the magazine's policy of presenting the many facets of model aviation.

Don James, Winston-Salem, N.C.

Having studied the results of our Readership Survey, AAM does not feel that there is sufficient reader interest at this time to justify having an entire column devoted to airship modeling. We will, however, be presenting articles on airships from time to time. This month, for example, we have an article in our Model World section (page 12) on Indoor modeling that will certainly interest you and all airship modelers.

—Editor

In search of a club

I have pattered around with model aircraft, all control line, for about five years and have begun looking for a club in my area. The trouble is that I've been a loner most of the time in my modeling efforts and even when asking at local

GET TOP PERFORMANCE!

USE

VIBRA-TAK

Slide Rule Tach.

Check the RPM's of your motor accurately. Instantly know what peak your motor is operating . . . get top efficiency and smooth running power. Engineer proven, VIBRA-TAK is a professional instrument built of polished, high stress aluminum. Carry it in your pocket or toolbox.



ONLY
\$5⁰⁰
including carrying case

Dealer inquires invited

Order from:
**VERDELL
INSTRUMENT
SALES CO.**

- CHECKS MOTOR SPEEDS
- INTERNAL COMBUSTION ENGINES
- ROTATING & VIBRATION EQUIP.
- GIVES DIRECT READINGS FROM 2000 TO 21000

P.O. BOX 212, EL CAJON, CALIF. 92020



M.n.M.
RADIOMODELS

929 S. CEDAR RD.
NEW LENOX, ILL. 60451
R/C PLANES - BOATS - CARS

P.O. BOX 28 - NEW LENOX, ILL. 60451
Phone: (815) 485-2898



R/C DISCOUNT CATALOG .50¢

SPECIAL CUSTOM PROPS

- highest quality maple
- perfectly balanced
- all popular 11" dia. sizes

PRICE: \$ 3.00 each

MOST ORDERS SHIPPED U.P.S. THE DAY RECEIVED

TAKE A TERN FOR THE BEST!

WINGSPAN 17 IN.



KIT NO.107
2.00

**PORTERFIELD
Collegiate**



WINGSPAN 18 IN.

KIT NO.108
1.50

**DRIFTY
Primary Glider**

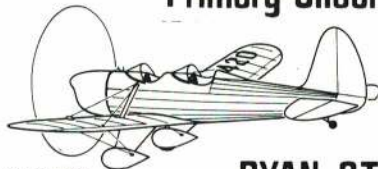

KIT NO.109
2.75

RYAN ST
WINGSPAN 17 IN.

SEE YOUR DEALER TODAY. IF UNAVAILABLE ORDER DIRECT. ADD 10% FOR POSTAGE & HANDLING. OUTSIDE U.S. ADD 15%.



TERN AERO CO., inc.
P.O. BOX 66398
CHICAGO, ILL., 60666

hobby shops, I'm unable to find anything other than a few local RC clubs.

RC is a bit above my budget. I am actually looking for almost anything else—Combat, Carrier, Free Flight, Soaring, perhaps even Racing. I am 25 years old and would like something competitive.

If any readers know of clubs in the Youngstown, Ohio area (60 miles south of Cleveland), please contact me.

R. E. Wardel, 15 E. Philadelphia,
Youngstown, Ohio 44507

BUD TENNY

(Continued from page 41)

match lets the model make full use of the available ceiling height, then the model will land just as the torque drops below critical torque.

Critical Torque: As an indoor model descends, the motor unwinds toward zero turns. A well-trimmed model will fly at a constant airspeed throughout the cruise and landing. For any given propeller and model speed, critical torque is that torque below which the prop stops pulling the model. Motor output below this level allows the prop to slow down enough to start acting like an air brake. If the model is very far from the floor at that time, a change in rubber size or in loop length can increase flight time substantially.

Which Way To Change?: The motor's drop to critical torque can happen two ways (an extreme example is used for emphasis). First, a small cross section motor will have a lower average torque output and critical torque will be reached while the motor has many turns left. Second, a large cross section motor can simply run out of turns. Both conditions are illustrated in the graph, which shows turns vs.

**"LOOK"
WHERE THE ACTION IS!**

The original ball socket.



If you are not using a "MISSING LINK" at this action point, chances are the hook up is more difficult and the linkage less efficient.

Still the same price.

Stk. #11 - .79¢ each with hdw.

Stk. #12 - .79¢ pair w/o hdw.

See your dealer or order direct
add .25¢ for post. & handling

ROCKET CITY SPECIALTIES

103 Wholesale Ave., N.E.
Huntsville, Ala. 35811

**ADVANCED
PUSH ROD SYSTEMS**

COMPLETE WITH ALL HARDWARE

from



PLAINFIELD, ILLINOIS 60544

NEW ProROD T.M.
THE RIGID PUSH ROD SYSTEM

NEW MASTEROD T.M.
THE Flexible Cable PUSH ROD

NYROD®
THE Flexible PUSH ROD

NEW MASTEROD-XF T.M.
THE Extra Flexible Cable PUSH ROD

DEPENDABILITY
is not just a word with us...



it's our way of life.

2 YEAR
WRITTEN
GUARANTEE



WRITE FOR DETAILS

by **SONIC-TRONICS INC.** 2 S. SYLVANIA AVE. PHILA., PENNA. 19111
The Worlds Largest Manufacturer of Model Engine Electric Starters.

THE BEST IN SCALE FROM TWO WARS

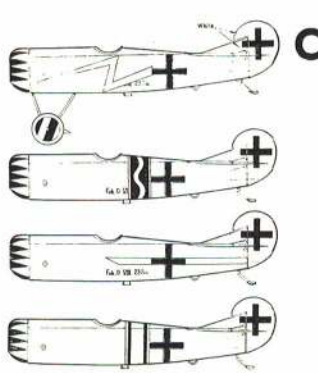

P47D THUNDERBOLT KIT \$64.95

Builds razor or bubble versions
1 1/2" scale EXACT, 61 1/4 span 60-80
Includes F/G cowl. Shipped P.P.
Price Includes FREE AIR Shipment in U.S.A.
Send .50 for new BEST IN SCALE CATALOG.

FOK. D-VIII \$15.95

2" Scale, 40-60 power.
Smi kit includes:
Plans \$3.50
Foam Wing cores \$9.00
ABS Cowl \$5.00
Also ref. 3-view, markings
and Lozenge camouflage data.



BOB HOLMAN PLANS

P.O. Box 741M, San Bernardino, Calif. 92402

- New Plans:
- Nieuport 28 2"\$5.95
 - Camel 2"\$5.95
 - FW Storch 1 1/2"\$6.95
 - Sop. Tripe 2"\$5.95
 - AT-6 Texan 1 1/2" \$5.95
 - FW 190A3 2'\$4.95
 - F4U 4 1 1/2"\$4.95
 - Zero 63"\$5.95
 - Hurricane 1 1/2"\$5.95
 - JU87B 60"\$5.95
 - Mosquito 63"\$5.95

Many more.

torque for two motors of the same weight. Motor A is short, with relatively large cross section and Motor B is a longer, thinner loop. "A" will take a maximum of 1600 turns and "B" will hold about 1800. However, with the same launch torque and critical torque, "A" will deliver about 1260 turns in flight, while "B" will deliver only 960 turns under the same conditions. At an average rpm of 60, this would represent five min. flight time! If a motor can be chosen similar to the dashed curve, useful turns will be nearly as great as "A" and a few more seconds flight may result from the slow drop in torque below critical torque.

AL RABE

(Continued from page 18)

conventional mid-wing stunt ship with Nobler moments.

Any discussion of originality or realism may soon be academic, anyway. At the 1972 NATS, our country's top competition stunt fliers got together and a majority decided to try to amend the rules to eliminate both originality and realism points from appearance judging. "What place do they have in stunt competition?", they asked.

I would like to attempt a partial answer. The smooth classic stunt ship of today evolved from an overweight, underpowered, flapless stunt ship which couldn't begin to match today's airplane for looks, performance or durability. This evolution was brought about by innovation and experimentation. Then as now, innovative ideas, departing sub-

DESIGNED FOR THE NEWCOMER TO R/C OR SPORT FLYER ●●●

Thor II

- ◆ Fully Custom Kit
- ◆ Accessories
- ◆ Full Size Plans
- ◆ Step-by-Step Instructions
- ◆ Finest Materials



\$28.50

FOB FACTORY
CA. RES. 5% SALES TAX

- WINGSPAN.....62"
- AREA..550 Sq INCHES
- ENGINE..... .15 to .29
- 1-2-3..... CHANNEL



P.O. BOX 2429 ORCUTT, CA. 93454

MIDWEST PRODUCTS COMPANY

HOW SWEET IT IS!



R/C SPORT TRAINER

Beginner
or Expert

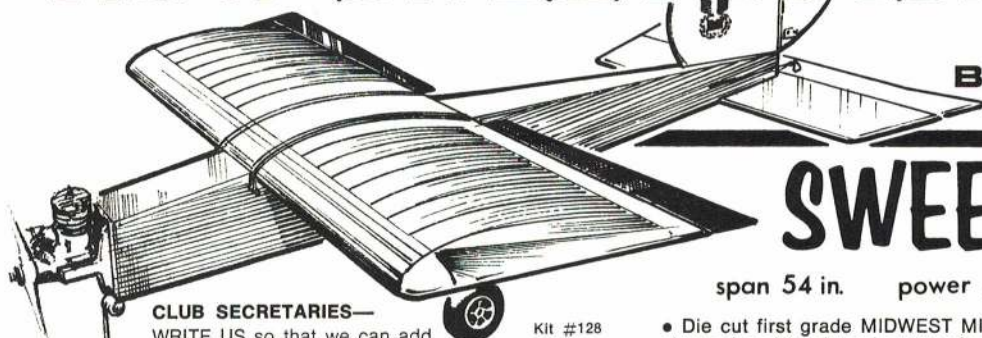

SWEET STIK

span 54 in. power .19 - .45 600 sq. in.

CLUB SECRETARIES—
WRITE US so that we can add you to our mailing list. Receive free our advance notices of new releases.
DEALERS—send for free catalog.

Kit #128

\$32⁹⁹

- Die cut first grade MIDWEST MICRO CUT balsa • All plywood and hardwood cut to size • Preformed wire
- Complete hardware package • MIDWEST aluminum engine mounts • Clear easy to read plan • SIMPLE and QUICK to build

SWEET FLYER—SWEET PRICE

MIDWEST PRODUCTS CO.
400 South Indiana St., Hobart, Indiana 46342

Please send me your illustrated catalog of models and accessories. I enclose 25¢

Name _____
Address _____
City _____
State _____ Zip _____

stantially from proven, workable configurations usually involved a loss of performance during the development stage. If the ideas had merit, and the loss of performance was less than catastrophic, a few extra appearance points frequently made the airplane competitive and gave its builder encouragement to strive for further development. This year I flew an airplane which was fatter, had a bigger engine, taller landing gear, shorter nose and longer tail than any other airplane entered. It also had a polyhedral wing, molded construction and an internal muffler. It won Open Stunt by less than the difference in appearance points. I can assure you, those few extra appearance points do, indeed, make a substantial difference and do encourage further experimentation. If you agree that these few points are a reasonable price to pay for continuing the trend toward better flying, more interesting airplanes, then contact your CL Contest Board member and tell him you oppose the removal of realism and originality from CL Stunt appearance judging.

Questions for Readers: To utilize this space for a maximum flow of useful information, we must communicate. Questions of general interest will be published and answered here. I'm going to ask some of you, too.

First, can anybody provide information on multi-engine stunt ships? In particular, were there any problems with vibration? Were there any problems with engine operation or fuel feed? How did they fly?

Second, has anyone information on bi-plane configuration stunt or sport ships? How realistic were they? How thick were the wing ribs? Did they use flaps? Was drag a problem in vertical or square maneuvers? How did they fly?

Third, While the O.S. 35 is certainly one of the best stunt engines available, some O.S. fliers need information to improve the operation and durability of their O.S. engines. Did you replace the venturi? What size venturi gave the best results? Did you pack the crankcase in any way? How are the new rods holding up? Have you tried the ST AA29/10 rod

FOX MOTORS FOR SPORT & COMBAT



FOX 29
\$14.95

WEIGHT.....7 OZ.
DISP.....299
RPM.....12,000
WITH 9-6 PROP

The fox 29 has the same cylinder, piston and head combination that proved so successful in the early racing 29X models. It is now fitted with a new crankcase and crankshaft with more counter-weight. We feel it is the finest running bushing 29 that you can buy. It takes the B size Fox Silencer.



FOX 36
\$14.95

WEIGHT.....7 OZ.
DISP.....359
RPM.....11,000
WITH 10-8 PROP

Fly combat? The new Fox 36 weighs 2 ounces less than the 36BB, yet has the same inside parts. It's the fastest turning gun in the west. For sport flying, the Fox 36 is hard to beat. For muffling use the B size Fox Silencer.

WRITE FOR FREE CATALOG

FOX MFG. CO.

5305 TOWSON / FT. SMITH, ARK. 72901

YOUR AMA NUMBER PRINTED ON 25th ANNIVERSARY NATS SHIRT



*Official Commemorative Two Color Insignia
AMA Number in LARGE 2" Characters
Contrasting Blue Trim*

Sizes: Mens - S,M&L - Youth-M,L&XL

\$3.50 plus 50¢ postage per shirt

Send size & AMA number to:

Fagel Brothers - Suite 2401

3930 Pine Grove

Chicago, ILL. 60613



BALSA GLIDERS

BALSA MODEL KITS



PAUL K. GULLOW, INC.
WAKEFIELD, MASS. 01880

"LIGHTNING-BOLT 21" *the*



- 1-1/2 LB.
- 21-3/4" LONG
- EASIEST KIT EVER
- FIRST .19 MONO OVER 30 M. P.H.
- HULL, DECK & PLANS - ONLY \$25.00
- COMPLETE '71' CATALOG 504 - PLEASE GIVE ZIP CODE WITH ALL INQUIRIES AND ORDERS

G.E.M. MODELS

P.O. BOX 342 - DEPT. AM
BROADVIEW, ILL. 60153
PHONE 312/279-2451

IN CANADA

ACADEMY PRODUCTS



EVERYTHING FOR THE MODELER

Canadian Modelers:
Write for an
ACADEMY CATALOGUE.
75 cents, Postage free. Wholesale only.

ACADEMY PRODUCTS LIMITED
51 Millwick Drive, Weston, Ont., Canada.

Canadian Dealer
Inquiries
Invited.

in your O.S.? What prop, fuel and tank volume do you use? Do you use muffler or crankcase pressure or a uniflow tank?

Fourth, has anybody had any experience with retracts on CL Stunt ships? How are they powered? What initiates retraction and extension? Did you build or buy your units? How reliable are they? How much weight did they add? Did landing gear retraction improve your pattern ship?

Finally, report what you see. The useful ideas will be passed along here. Tips about particularly interesting airplanes may result in quality construction articles in AAM.

Tip of the Month: Cut both ends off of your ready-made control lines which have crimped tubing type line terminations and redo the ends yourself. My Mustang II was destroyed because a tight crimp had broken strands of the cable inside of the crimped tube where the damage was invisible. The lines survived a half season of AMA and FAI pull tests and were clean and free of kinks or visible damage when the accident occurred. After that, I wrapped my own lines as shown on page 19 of AMA 1972 Rule Book (Fig. 2) two line construction. These solderless terminations worked fine until one day I hung up the serving wire twists on each other where they were attached to the very close spaced (1/2") Mustang leadouts. After one quick snag in flight, they let go and operated normally thereafter. Nevertheless, I wrap the same as before with Sig serving wire but now I solder the wraps with rosin core solder and minimum heat. I found out later that you don't see many sets of ready-mades on finals day at the NATS. Also, most good fliers use the Pylon Brand 110-lb. line connectors.

Preview: Soon to appear in the pages of AAM will be Mark Freeman's Spitfire Mk XIV. This has just got to be one of the best-looking competition stunt designs around. It features a molded balsa fuselage, ST 46 power, long tail moment and a full range of trimming adjustments including adjustable leadouts and tipweight, moveable rudder, variable ratio elevators and much, much more. Watch for it.

BOB HATSCHKE
(Continued from page 26)

a lot closer to the actual stress in the shaft than safety would dictate. Remember, no safety factor has been included in any of the calculations.

The simplest solution to this weak point is obviously to use a larger diameter, but what isn't obvious is how big a difference will be made by just going up one notch to the next larger standard thread, a 5-40. A 5-40 thread has an outside diameter of exactly 1/8" (so it wouldn't even be necessary to change the basic wire size or turn it down for threading) and a root diameter of .094". Going back to the stress formula, you'll note that stress is inversely proportional to the cube of diameter. This means that a small change in diameter has a very powerful effect on stress. So even though the diameter is only 16% greater, the strength is actually increased by 57%. Or, more precisely, stress under a torque load of 105-in.-oz. is only about 40,000 psi.

INDEX TO ADVERTISERS

MARCH 1973

Academy Products, Ltd.	104
ACE Radio Control, Inc.	30, 39
Aero Precision	92
Aerotech Engineering	98
Airborne Associates	98
Aldrich, George	97
Associated Hobby Mfg.	85
Bachmann	83
Boyd Models	82
Broz Enterprises	94
C.B. Enterprises	65
C & H Sales	89
Calgary Hobby Supply	91
Cannon Electronics	79
Cleveland Model & Supply Co.	97
D.A. Enterprises	79
Dembros Hobbies, Inc.	87
Diane Publishing Company, The	85
Dremel Fg. Co.	81
Du-Bro Products, Inc.	31
Dumas Products, Inc.	51
EK-logictrol	9
Fabra-Tex Corp.	89
Fagel Brothers	97, 103
FAI Model Supply	102
G.E.M. Models	104
Fox Mfg., Co.	103
Galler Electronic Ind.	99
Goldberg Models, Inc., Carl	7, 15
Graupner, Johanne	61
Grish Bros	78
Guillow, Paul K., Inc.	104
Hannan, W.C.	102
Harvey Products, Inc., Paul	88
Hathaway, John	99
Heath Co.	77
Hobby Centers	76
Hobby Helpers	93
Hobby Hideaway	89
Hobby Lobby	16, 17
Hobby Market, The	78
Hobby People	10, 11
Hobby Shack	54, 55
Hobby World	97
Holman, Bob	81
Indy R/C Sales	90
Inky, Flight Boxes by	102
Johnson Smith Co.	95
K&B Manufacturing	86
K&S Engineering	73
Kayeff	87
Kraft Systems	Inside Back Cover
M-n-M Radiomodels	101
Micro Models	100
Midwest Products Co.	103
Miniature Aircraft	92
Model Materials Co.	91
Model Rectifier Corp.	Outside Back Cover
Morgan, Sid	96
National Hobby	92
Nelson Model Products	100
Northfield Precision Instrument Corp.	76
Octura Models	86
Orbit Radio	72
Pactra Industries	93
Phil-Leys	95
Pro-Line Electronics	91
R/S Systems	78
Randy's Corner	89
Rocket City Specialties	101
Royal Electronics	94
Scientific Models, Inc.	Inside Front Cover, 3
Sig Mfg Co., Inc.	58, 59
Sonic-Tronics, Inc.	102
Stafford, Jack Models	8
Sterling Models, Inc.	46, 47
Superscale	87
Su-Pr-Line Products	101
Tatone	88
Tern Aero Co.	101
Terry Plane	102
Testor Corp.	90
Texas Models Unlimited	95
Thermo-Jet Standard, Inc.	94
Tiny Tots	92
Top Flite Models, Inc.	63, 71
Tower Hobbies	23
Verdell	100
Vortex Engineering	96
Williams Bros.	81
World Engines, Inc.	74, 75
X-Acto, Inc.	82
Zaic Co., Inc., C.A.	26

TAKING OFF?

LET US KNOW WHERE YOU LAND!

When you move please let us know in advance—five weeks notice would help! Attach a current AAM mailing label in this space, check the appropriate box below and mail to: Subscription Dept., American Aircraft Modeler, 733 15th St., N.W., Washington, D.C. 20005

WANT TO SUBSCRIBE OR RENEW?

Check appropriate boxes and enclose payment (Offer limited to U.S.A. and Canada).

CHANGE OF ADDRESS NEW SUBSCRIPTION RENEW SUBSCRIPTION

1 Year \$7.50 2 Years \$14.00 3 Years \$20.00

NAME _____

ADDRESS _____

CITY/STATE _____ ZIP _____

AMERICAN AIRCRAFT MODELER / 733 15th St., N.W., Washington, D.C. 20005

AMERICAN aircraft modeler

a Potomac Aviation Publication
EDWARD C. SWEENEY, JR., Editor and Publisher
Washington, D. C. 20005
733 Fifteenth Street, N.W.

Phone (202) 737-4288

AN OPEN LETTER TO ALL AMA MEMBERS

FROM: Edward C. Sweeney, Jr., President, Potomac Aviation Publications, Inc.
DATE: January 11, 1973
SUBJECT: The Magazine Controversy

To quote your Executive Director: "This is a letter I should not have to write." It has become necessary to answer the various accusations and misleading attacks brought upon the AMA by RCM magazine over the years, and recently by MAN. These magazines accused the AMA, its council and its Director of creating a situation of unfair competition between the model magazines by entering into an illegitimate agreement with Potomac Aviation Publications to publish the official news of the AMA in each issue of AAM and to supply the issues to the general membership. There is absolutely no truth in any of these accusations. There is no reason for the attacks upon the integrity of the AMA. The agreement between the AMA and Potomac is legitimate, and necessary to the continued growth of the Academy as the official national organization for model aviation activities. This agreement is in no way advantageous, in its present form, to AAM as part of a profit-making corporation. The agreement is financially hazardous and always has been. In no way is the AMA in a position to subsidize AAM or Potomac as a private enterprise.

This agreement came about as the result of a friendship and formal association between my father, Edward C. Sweeney, Sr., who in 1966 was the President of the National Aeronautics Association and John Worth the Executive Director of the Academy of Model Aeronautics. The publication, *American Modeler*, was to be terminated by its former owner, Conde Nast of New York. They had simply lost interest in the model field and had no staff members involved in the hobby. The magazine had lost circulation and advertising. It suffered with the demise of the slot car business and had become a bi-monthly magazine.

My father heard of the magazine's situation and, as Bill Winter was available to head a company and run the business of publishing the magazine, Dad proposed that I invest in starting this business. At the same time, in 1966, the Academy was deeply in the red; membership had fallen to around 15,000 hard-core modelers and no publishing company was at all interested in giving the AMA the support it needed (other than trophies at the National model meet). It seemed appropriate and no publishing agreement was worked out. It was described to the competing Modeler. Between Bill Winter, John Worth, and my father, a proposed agreement was fully discussed by the AMA's Executive Council. The agreement was also described briefly to the AMA's Leader Members for their opinions. Everyone was in favor of the agreement except for competing magazines who had hoped that *American Modeler* would quietly die. They saw the agreement as saving one of their competitors, so they attacked the agreement. They never tried to get the business for themselves. Imagine that—they didn't want the business and yet accuse AMA of an unfair agreement with a competitor!

In 1966 the agreement was to publish the material of "Model Aviation," AMA's monthly self-covered, 24-page publication (it went to all members, carried advertising, and was sold at hobby shops) in *American Modeler* and for the Academy to buy the magazines at 10 cents each for the members. As Potomac Publications had no in-house subscription system and AMA had the equipment and know-how, Potomac bought this subscription fulfillment service from AMA. AMA had gained having exposure in a nationally distributed magazine. The membership now got a complete publication of 72 pages, advertising, model articles, etc. There was no increase in membership dues to do it either. Immediately, AMA's leadership and editorship, the magazine began growing through better distribution, better editorial material, no more slot cars, etc. The growth manifested itself in transferring readership to the AMA. This seemed perfectly all right. There were not that many AMA members in the total circulation and we wanted to help AMA gain members.

Eventually, AMA's growth meant that the AMA-run subscription service was quite busy with new AMA members and AMA wanted to terminate the AMA-run subscription part of the agreement. AAM had to establish its own in-house subscription operation. The cost of producing the magazine went from roughly 24¢ cents each copy printed in 1966 (that's printing, overhead, production, distribution, etc.) to presently 37½¢ cents per copy. The magazine increased from 50 cents each at newsstands, to 60 cents, then to 75 cents and now is \$1. Potomac's remittance for copies sold at the newsstand is 50 percent of the cover price. Remittance from hobby shops is 60% of the cover price. Subscription rates went from \$5.25 in 1966 to presently \$9. Talk about inflation in this country! It happened to all the other model magazines at approximately the same time and the same amounts. BUT, payments to us for AMA copies were always way behind the cost of producing the magazine and way way behind the other normal remittance for sales. YET AMA HAS BEEN ACCUSED OF SUBSIDIZING THIS MAGAZINE!

Of the dues increase of this year, Potomac's total increase per year per member was 60 cents out of the \$5 membership fee increase, hardly the majority of it!

AMA's Executive Council has openly approved the various changes in the publishing agreement over the years between the magazine and the Academy. At every agreement comments and bids from RCM, MAN, and FM were sought. None were received. Instead RCM attacked the AMA in editorials. MAN and FM remained silent. RCM always points to the large annual budget expenditure for AAM copies. The Executive Council has changed faces during these years and still likes the agreement with its changes. RCM then began claiming that AAM's readership is merely captive and not really interested in having the magazine anyway. Perhaps it is to some, but AMA membership is big and growing. Back in 1966 membership was declining to 15,000 members but today it is nearly 50,000 members. The most significant reason for the previous membership decline was the absence of a more complete magazine in the membership package. Since then, with membership growth, the Academy has greatly expanded its services, established a strong Charter Club program, better insurance, etc. There is real danger for the AMA in taking the magazine away from its membership package unless it can offer something similar. For AMA to go into the magazine publishing business with an equivalent magazine to AAM would be prohibitively expensive and would eliminate the exposure factor of having the AMA Official News in all issues of a national magazine.

There are two areas where there is some truth to the proposition that AAM benefits directly from its agreement with the Academy. One is certainly the prestige factor of including the official news of the national organization. The other is that the AMA members are very much involved in their hobby/sport and are good supporters of advertising. The claim is made that AAM's growth in advertising is because of the AMA readers. Perhaps to a small degree this is so, but the advertising totals in RCM and MAN are not much less than AAM. The advertising rates in these magazines are almost exactly the same as for AAM. In other words, AMA readership support of advertising is not a major factor as claimed. AAM's growth in advertising is the result of building its circulation so significantly no matter who the reader is. The growth is also because of the magazine's editorial policies under Bill Winter, Harry Harps, and myself. When readers like it, they buy it. The more readers you have the more advertisers you should have. Incidentally, our Owner's Statement appears in the January 1973 issue for the past year's circulation and it is absolutely accurate. To the best of our knowledge, RCM has about half as many readers and MAN is several thousand readers less than AAM. AAM can justifiably claim to be the world's largest model aviation hobby publication.

Because it is harmful to the AMA, and therefore our hobby/sport in general, Potomac Aviation Publications, Inc. wants to help end the hassle about its agreement with the AMA. It also is fed up with being accused of a sweetheart agreement. We have supported and hope to continue to support the AMA. The hobby/sport of model aviation needs the association and does not need this hassle. We will be asking the AMA to make the magazine optional for the members and at a profitable rate. We will also propose arrangements to supply only the AMA sections to those members who are satisfied with having just that. The Executive Council meets in February 1973 (an annual meeting in Washington, D.C.). This meeting does not normally consider its agreement with Potomac. RCM and MAN editorials have caused the Council to reconsider the agreement. As a result Potomac must also reconsider the agreement. We don't want to continue the present financially dangerous arrangement in the face of present inflation. The Executive Council should be able to act with wisdom and have the advice of its members. The only purpose of this letter is to give "our side" of the controversy. We wish to continue to support the AMA and its growth.

The above statements are true and factual to the best of my knowledge.

Subscribed and sworn to before me
this 15th day of January, 1973

Barbara H. Guth
Notary Public, D.C.
My commission expires: Sept. 30, 1976

Signed,

Edward C. Sweeney, Jr.
Edward C. Sweeney, Jr.
President, Potomac Aviation Publications, Inc.

This letter is being printed in AMA subscription copies exclusively.



Editor:
Carl Wheeley

MODEL AVIATION

Official magazine

A.M.A. NEWS



Academy of Model Aeronautics • 806 Fifteenth Street N.W., Washington, DC 20005

INTERESTED IN JOINING A.M.A.? Over 46,000 did in 1972. Details may be had by requesting FREE BROCHURE from above address.

AMA'er Discovers New Autopilot Principle

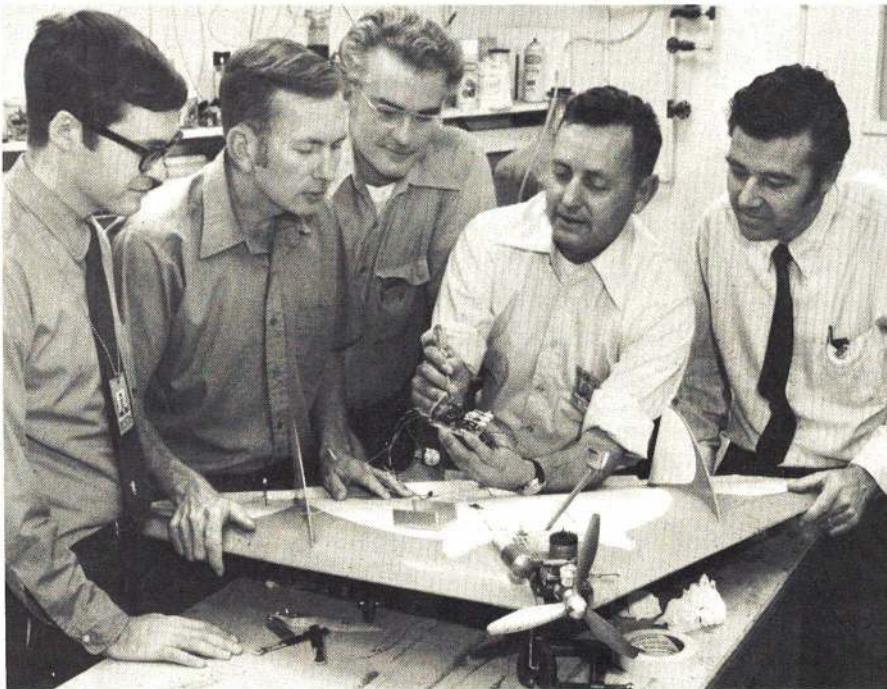

The discovery by Maynard L. Hill of a miniature autopilot having no moving parts, utilizing static electricity measurements of the atmosphere, has resulted in perhaps the most significant recognition ever accorded modeling by the scientific community and others. Hill's device is small enough to fit into the palm of one's hand, and the component parts may be bought from electronic supply houses for less than \$100.

Hill is a former AMA president (AMA 14) and is the current AMA voting delegate to the Federation Aeronautique Internationale (FAI) Committee for International Aero Modeling (CIAM). An outstanding modeler, he has held more modeling world records than any other individual.

The importance of the electrostatic autopilot is demonstrated by the cover treatment and 10-page feature in the November issue of the prestigious *Astronautics and Aeronautics*, the magazine of the American Institute of Aeronautics and Astronautics. "The basic device consists of a patch of radioactive material mounted on each wing tip and on the nose and tail of an aircraft along with two highly sensitive differential voltmeters," Hill said. The voltmeters actuate servos to create "a stabilization system which, under the conditions we have flown, appears equal to conventional

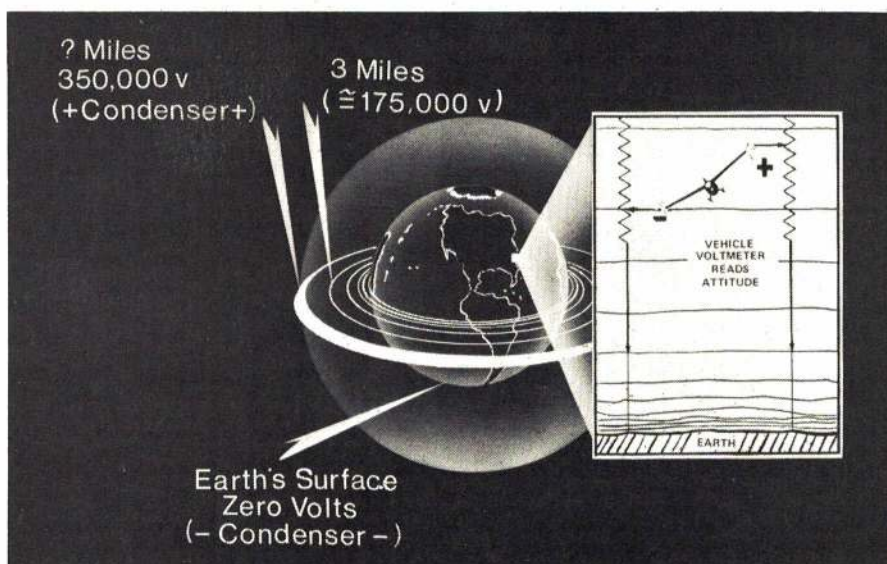

Upper: Long time AMA'er, former AMA president, currently AMA's FAI CIAM voting delegate, Maynard Hill holds the electronics of the pitch and stabilization mechanism which employs the earth's electrostatic voltage levels to keep the aircraft in undisturbed flight. With him (L-R) are John Rowland, Ben Givens, Ray Cole, (Hill), and Christopher Keller, members of the team which aided in development of the system.

Lower: Illustration of the conditions which provide for electrostatic stabilization. What appears as "Saturn rings" surrounding the earth should be interpreted as a cross-section of the atmosphere—much the same as the layers of an onion. The concept of uniform static planes in the atmosphere is not new, but Maynard Hill and his colleagues discovered how truly horizontal and stable these "tracks" really are—and how to utilize them. Illustration and photos by the Applied Physics Laboratory of The John Hopkins University.



Kodak Show Theme: Up, up in the Air

Report and photos by Bill Boss

Model aviation was shown as a co-equal partner with other facets of aviation in the two-month exhibit (September 27 to November 20) at the Kodak Photographic Gallery and Information Center in Manhattan, N.Y. The show, which was co-sponsored by Air Progress Magazine, covered all forms of airborne recreational activity—ranging from the flying of kites, to models, to full-scale aircraft. Also included were activities such as ballooning, skydiving, aircraft maintenance and satellite photography.

As expected, most of the show was presented photographically by means of movies, slides and prints, including clips from AMA's 1971 RC World Championships film.

Models and full-scale aircraft also had their place in the show's overall theme. Historical aircraft were represented by Cole Palen's 1909 Bleriot while Jim Bede's experimental 16-foot wingspan BD-5 showed the latest sport flying plane that can be obtained in a "do-it-yourself kit."

Modeling had a great part in the show, with all facets of our hobby-sport being represented: RC Pattern and Scale by Al Stroman and Ted Tobias of the Pennsylvania Ave. RC Society; CL Speed, Stunt and Scale by Frank Garzon, Nick Arpino, Bob Lampione and Bill Boss of the Assn. of Model Airplane Clubs of Greater N.Y.; FF Rubber, Gas and Glider by Bruce Paillet and Bob Hatschek of the Long Island Assn. of Model Airplane Clubs; Indoor models by Bob Clements (Kodak staff photographer) and his son, Christopher. Also exhibited were plastic scale models from the International Plastic Modelers Society and model rockets from the National Association of Rocketry. There were about 30 models of all kinds in the show.

The opportunity for AMA and modeling to participate in this great show of air recreational activities came about in early August when the author, then AMA District II vice-president, received a request from Kodak for assistance. Realizing that here was a fantastic chance for getting modeling before thousands of people, he made the necessary contacts with the modelers previously named who, by the way, were most anxious to participate once the show's theme was explained. Each selected his best models, several of which had been National and World Championships winners. With the opportunity to participate in a most professional show, the idea was to put the best on display.

One of the most interesting aspects of working with Kodak was that they seemed to know just what kind of models they wanted. Then it was learned that many of the Kodak people involved were or are modelers and AMA members.

It was a great opportunity to have been able to work with Kodak and Air Progress in the modeling portion of the show. Modeling's story was told well and in its rightful place alongside full-scale aviation and other airborne recreational activity. All of the AMA member modelers who participated in the show say that it was a great honor and pleasure to have been part of Kodak's Up, Up in the Air.



Maynard Hill, left, and Ben Givens prepare for testing planes rigged with the autopilot.

systems employing precision mechanical gyros." Both quotes are from A & A, which is complete with circuit diagrams and test data.

Hill's discovery came about in connection with his position with the Applied Physics Laboratory of The Johns Hopkins University. While participating in clear air turbulence investigations for the laboratory, using RC airplanes, he found clues that the atmosphere's phenomenon (voltage levels which increase with altitude) could be used as "tracks" for aircraft to ride with great stability. "The only unbelievable aspect of all this," Hill was quoted in the APL's own paper, "is that there has been no prior art dealing with this particular combination of physical phenomena in a practical device for aircraft stabilization." This is despite the fact that electrostatic conditions surrounding the earth have been well known to atmospheric physicists for a very long time.

Members of the team of APL scientists working with Hill at the time of the discovery: John Rowland, Robert Givens, Ray Cole and Christopher Keller. Like Hill, Givens and Cole are AMA members, and two additional AMA members, Bill Charbonneau and Al Passori, have subsequently joined the team.

Use of these principles outside the field of aviation was brought out in an interview with Hill by Associated Press writer Vern Haugland which was widely printed. In noting that the control surfaces wiggle when walking near the model when the autopilot is activated, it occurred to Hill that this might be the basis for a simple burglar alarm... of collision avoidance systems... of airborne prospecting for mineral deposits (since radioactivity in the earth affects the conductivity of air at low altitudes)... of detecting pollution sources.

How about use of the autopilot for model airplanes for sport and hobby purposes? Undoubtedly there will be much said in AAM and other model publications. As a starter, read Don Lowe's column in this issue.

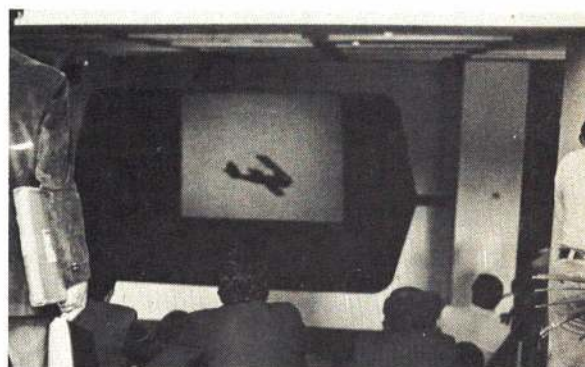

Above: Many found the Kodak show a great way to spend a lunch hour. Movie of RC flying being shown. Below: Table-top display of smaller airplanes and space models was shielded from prying hands by Plexiglass case.

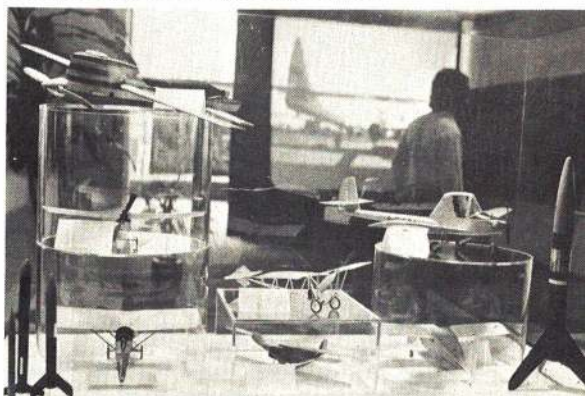

Above: Larger models were wall mounted. All types shown: RC Pattern and Scale; CL Speed, Stunt and Scale; FF Rubber, Gas and Glider; Indoor. Below: Cole Palen's 1909 Bleriot represented historical aircraft.





PRESIDENT'S MEMO

WHO THE HECK MAKES AMA'S DECISIONS, and EXACTLY HOW? (OR "who spends our money?")

The answers to the above questions are in AMA's by-laws, but most documents of that nature require a bit of interpretation for the average citizen. After the seeming "thousands of years" of my association with AMA and its rules and problems, it is a little difficult for me to think from the viewpoint of a new or prospective AMA member. But I am going to make a gigantic effort to do exactly that! And considering the mail we keep receiving aimed the wrong direction, I think it would be an excellent idea for even the "acquainted" members to review what I shall say, to be sure we (AMA) are on the right track.

WHO RUNS AMA? ISN'T IT REALLY A FACT that the executive director (in this case, John Worth) runs AMA? PLEASE LET ME SHOUT THE ANSWER TO THIS! AMA is actually run by the membership, represented by a 14-man Executive Council! No, the executive director does NOT run AMA. That is, unless the membership is so disinterested and the council so weak that the executive director has little alternative but to make the decisions.

An executive director CAN and/or WILL run AMA JUST AS MUCH as he is required or allowed by the membership. The office of executive director is a salaried and purely administrative one, established for the purpose of carrying out the wishes and orders of the AMA elected Executive Council and/or AMA's elected president. The executive director's services can be terminated by the AMA president with the approval of the Executive Council.

During the past administrations many of AMA's important decisions WERE made by whomever the executive director happened to be, without proper authority, simply BECAUSE THE DECISIONS HAD TO BE MADE BY SOMEONE, AND THERE WAS NO ONE ELSE AVAILABLE AT THE TIME TO MAKE THEM! Those with the responsibility either didn't understand their responsibilities, did not make themselves available, had not studied the problems, or just plain "ducked" the responsibility. When the executive director went ahead and made the decision, he was wrong any way he went! If he made a correct decision, he was WRONG for having made it at all. If he made a bad decision, then he SURE was in trouble.

Under this burden of decision-making, I watched our executive director being only about halfway efficient simply because he spent half of his time unfairly having to defend his actions because SOMEONE ELSE had not met their responsibility. The result was that AMA's primary employee was actually unhappy and inefficient, with a great loss of time and membership money as the membership's reward. Having discussed this most important problem with Mr. Worth, and related ones, resulted in my running for the office of president. I ran not just once, but THREE times before being elected. I was determined to find out just what progress AMA

Who Spends AMA's Money?



Dedication! This memo by AMA President Clemens was written from Gaston Episcopal Hospital.

could make if this fine experienced (by now!) employee was given the proper support.

The result of the above is all too evident. AMA has grown like mad, and the red ink has turned to black, and it is only a beginning! Instead of the executive director spending his time defending his actions and decisions, with the decisions now being made at the proper time by the proper authority, he is now able to be 100% productive, creative, mobile, and all this with a smile on his face. Since he is the "boss" of the HQ staff, his new cheerfulness and enthusiasm has rubbed off on all of the other employees! It is a mighty different office. They handle a t-r-e-m-e-n-d-o-u-s amount of detail, serving our 46,000-plus membership, and a spirit of PRIDE shows up at every desk. AMA has a fine HQ staff!

NOW, WHO DOES MAKE AMA'S DECISIONS? The purely business ones are made in our headquarters office. Matters of policy or requiring executive action I usually make as president, when I feel I am qualified. If there is any doubt in my mind, then some or all of the other council members are contacted by mail or phone for guidance. IF THE DECISIONS ARE OF MAJOR NATURE, they are made by a vote of the entire Executive Council, either by mail or in the regular meetings of the council, customarily held twice a year. This same council can reverse or override any decision made by the president if they feel the decisions have not been correct. The AMA EXECUTIVE COUNCIL in total consists of an elected president, an elected secretary-treasurer, the executive director, AND ELEVEN GEOGRAPHICALLY SEPARATED DISTRICT VICE-PRESIDENTS, dividing up the entire UNITED STATES, AND ELECTED BY YOU TO REPRESENT YOU PERSONALLY IN THE COUNCIL'S ACTIONS. Beyond all of this authority, the by-laws which provide for it can be altered by a vote of the membership, under extraordinary circumstances. This is as democratic as an organization of this type can possibly be set up, for the numbers involved.

BUT AMA CAN ONLY BE TRULY DEMOCRATIC IF YOU, YOURSELF, TAKE AN ACTIVE PART! An active part means that you have a responsibility to express your wishes WHERE IT WILL DO SOME GOOD!

This simply means to contact YOUR OWN district vice-president, because he will vote for YOU in the council's decisions. And if your district vice-president doesn't work, or you feel he does not represent you and the majority of modelers in your district, vote him out of office. Even consider offering your own services, because we always need qualified volunteers. I can tell you from personal experience that the salary that goes with these volunteer offices (\$0.00) is lousy, but the inward satisfaction is great! And we all have a debt to pay for the fun we've had from modeling.

I regret to say that the people who most need the above information of how AMA "works" are the ones least likely to read this. Therefore, YOU, as a person who was interested enough to have read this far, can help us run AMA by making sure that this information gets to all other modelers. It should be read and discussed at meetings, printed in newsletters, and called personally to the attention of all the modelers that you know.

THIS IS AN APPROPRIATE TIME TO CONGRATULATE AND WELCOME THE NEW COUNCILMEN, and to thank the retiring ones. This entire group of both incoming and outgoing officers are certainly among the most dedicated and dependable of all of AMA's servants. These are people you can put deep faith in because they have willingly accepted the sacrifices they are called on to make while serving you. I hope I personally represent the dedication of AMA's leadership group, the Executive Council, when I mention that this article is being written from Room 230 of the Gaston Episcopal Hospital in Dallas while I was recovering from some corrective surgery that I "enjoyed" just three days earlier. I am a little concerned because the doctor didn't use epoxy glue, but the surgery was successful in spite of the primitive (in the eyes of a dedicated modeler) methods.

Prayer for Every Day

*God, give me sympathy and common sense
And help me keep courage high.
God, give me calm and confidence,
And—please—a TWINKLE in my eye.*

John E. Clemens
AMA President

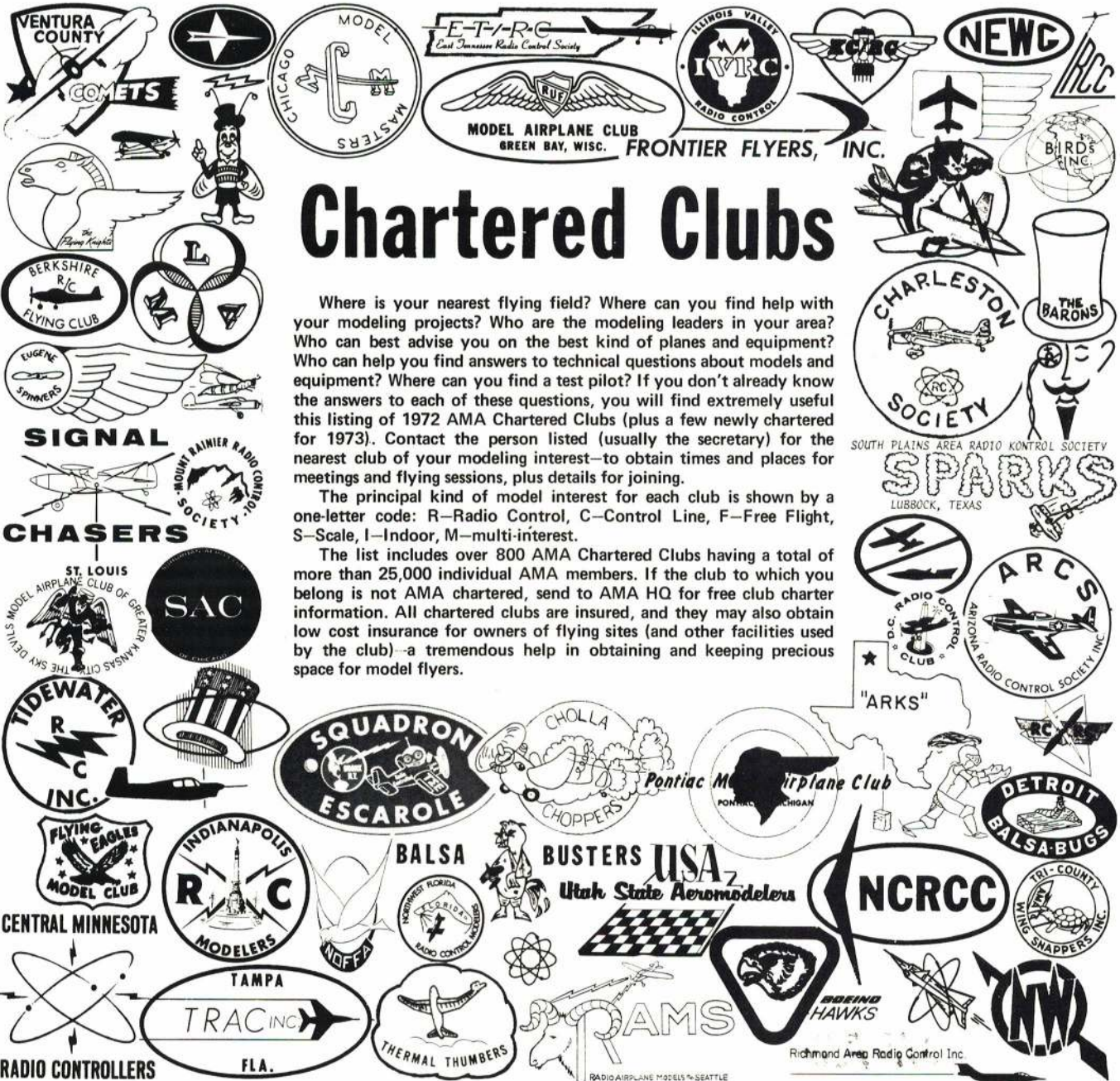

Chartered Clubs

Where is your nearest flying field? Where can you find help with your modeling projects? Who are the modeling leaders in your area? Who can best advise you on the best kind of planes and equipment? Who can help you find answers to technical questions about models and equipment? Where can you find a test pilot? If you don't already know the answers to each of these questions, you will find extremely useful this listing of 1972 AMA Chartered Clubs (plus a few newly chartered for 1973). Contact the person listed (usually the secretary) for the nearest club of your modeling interest—to obtain times and places for meetings and flying sessions, plus details for joining.

The principal kind of model interest for each club is shown by a one-letter code: R—Radio Control, C—Control Line, F—Free Flight, S—Scale, I—Indoor, M—multi-interest.

The list includes over 800 AMA Chartered Clubs having a total of more than 25,000 individual AMA members. If the club to which you belong is not AMA chartered, send to AMA HQ for free club charter information. All chartered clubs are insured, and they may also obtain low cost insurance for owners of flying sites (and other facilities used by the club)—a tremendous help in obtaining and keeping precious space for model flyers.

ALABAMA

- Birmingham RC Assn., Gerald Carlson, 4116 N. Cahaba Dr., Birmingham 35243 R
- Confed. Min. Air Force, Wm. Padgett, 53 Hudgins Ln., Birmingham 35214 R
- Decatur MAC, John Brownlee, 2407 Quince Dr. SE, Decatur 35601 R
- Ft. Rucker RC Club, William Polley, 109 Magnolia Cir., Enterprise 36330 R
- Gulf Coast RC Club, Alvin Reed, 57 Mohawk St., Mobile 36606 R
- Highwaymen RC Club, Patrick Hollock, 5645 9th Ave. S., Birmingham 35212 R
- Huntsville Aeromodelers, Rex Powell, 408 Glencoe Rd. SE, Huntsville 35802 R
- MAC of Huntsville, Morris Penny, 2105 Rosewood Cir., NW, Huntsville 35810 M
- Radio Aeromodelers, R. Miller, 314 Spring Valley Rd., Montgomery 36111 R
- Rocket City RC'ers, T. Smith, Box M65, RD No. 4 Slaughter Rd., Madison 35758 R

ALASKA

- Capital City Radio Model Club, L. Baird, Box 675, Juneau 99801 R

ARIZONA

- Air-Zona MAC, Tom Kilday, 6544 N. 13th Street, Phoenix 85014 C
- Arizona RC Society, Walt Teel, 11017 N. 38th Place, Phoenix 85028 R
- Arizona Soaring Club, Andrew Tickle, 8535 E. Amelia, Scottsdale 85251 R
- Cholla Choppers MAC, Shirley Dierdorf, 615 N. Desert, Tucson 85711 C
- Condors, Luke Arizona, Jimmie Jones, 1574 Apache, Glendale 85301 R
- Mesquite Modelers of Sierra Vista, J. Weakly, 226B Jeffords St., Ft. Huachuca R
- Min. Aircraft Pilots Assn., W.F. Still, 1259 E. Pebble Beh. Dr., Tempe 85282 R
- Tucson RC Club, Allen Scholz, 6555 E. Marta Hillgrove, Tucson 85710 R

ARKANSAS

- Fayetteville Aeromodelers, A. MacLean, Rt 2 Box 168-A, West Fork 72774 R
- Mid Arkansas RC Society, W. Roberts, 205 Lanehart Rd., Little Rock 72204 R
- Pine Bluff RC MAC, Norman Ross, 1909 Edmay Dr., Pine Bluff 71601 R

CALIFORNIA

- American Model Airport Assn., D. Skelton, 2167 N. Towne No. 3, Pomona 91767 R
- Antelope Valley Tailwinds Inc., Bob Moorhead, 1114 Nugent St., Lancaster 93534 R
- BARKS, Inc., Jerry Boyce, 2625 Alder, Bakersfield 93301 R
- Barstow Desert Cadets, R.D. Sides, 1648 Paloma, Barstow 92311 R
- BIRDS, Inc., C.B. Smith, 4341 Graywood Avenue, Long Beach 90808 R
- Black Bart Flying Club, Leroy Still, 150 Caldwell, Cloverdale R
- Cal Expo RC Flyers, Charles Sala, 5106 Cimarron Way, Sacramento 95842 R
- Calif. Aeromodeling Soc., Sandy Norton, 1016 E. Mission, Pomona 91766 F
- Capitol Condors Inc., Craig Stout, 8417 Citadel Way, Sacramento 95826 F
- Central Valley RC Club, D. Pertuit, 519 No. N Place, Tulare 93274 R
- Chico RC'ers Inc., Norman Bowles, 10511 Schroeder Rd., Live Oak 95953 R
- Chica Pins, Lynn Miller, 8 W. Mulberry Avenue, Porterville 93257 C
- Conejo RC Modelers, Dan McCan, 28 Wales Street, Thousand Oaks 91360 R
- Cordova Model Masters, Lee Helsel, 4392 Dorking Court, Sacramento 95825 R
- Diablo Valley Radio Controllers, PO Box 1084, Concord 94522 R
- Eastern Sierra Flyers, Wilson Rose, PO Box 77, Bishop 93514 R
- Escadrille MAC, Paul Isenhower, 921 Byron Lane Apt. F, Modesto 95350 C
- Eureka RC Club, Ray Lay, 2211 F Street, Eureka 95501 R



First All Speed Team, T. Granger Williams, 181 B St., San Marcos 92069 R
 Ft. Ord RC Club, Richard Alpina, 740 Sausal Dr., Salinas 93901 R
 Fresno Gas Model Club, Bill West, 2972 East Floradora Ave., Fresno 93703 F
 Fresno Radio Modelers, Thomas Ewing, 5075 E. McKenzie, Fresno 93727 R
 Harbor Soaring Society, R. Satterlee, 2049 Vista Cajon, Newport Bch. 92660 R
 Kings County Radio Controllers, D. Boaz, 18135 Burlwood, Lemoore 93245 R
 Long Beach Glider Guilders, D. White, 2213 Lakewood Blvd., Long Beach 90815 R
 Marin RC Group, Ben Ostlund, 19 La Crescenta Way, San Rafael 94901 R
 Min. Aircraft Radio Kontrol Soc., C. Comstock, 834 E. Virginia St., Rialto R
 Mission Bay Prop Twisters, Charles Johnson, 10375 Baron Dr., San Diego 92126 C
 Modesto RC Club, Lee Rosendaal, 2215 Powell Dr., Modesto 95350 R
 NAR Flightmasters, Fernando Ramos, 19361 S. Mesa Dr., Villa Park 92667 S
 North Bay Soaring Soc., L. Whitehead, 1923 Markwest Spg. Rd., Santa Rosa R
 Northrop Modelers, Charles Spurrell, 12111 Griville Apt. E, Hawthorne 90350 R
 Oakland Cloud Dusters, Carl Parsons, 202 Linda St., Piedmont 94611 F
 Orange County Thunderbugs, L. Gerber, 6602 Kiowa Rd., Westminster 92683 C
 Palomar RC Flyers, John Cutler, 830 Raintree Pl., Vista 92083 R
 Peninsula Channel Commanders, J. Alley, 1040 El Camino Real No. 306, Burlingame R
 Pioneer RC Club, Inc., W. Sievert, 18866 Afton Avenue, Saratoga 95070 R
 Pomona Valley MAC, Tony Lopez, 10195 Santa Anita, Montclair 91763 R
 Quarter Midget Racing Club, K. Holden, 3114 S. Lowell St., Santa Ana 92707 R
 Radio Aircraft Control Establishment, R. White, 2106 Tipton Way, Fairfield R
 Radio Aircraft Modelers, Robert Borges, 2990 San Felipe Rd., Hollister R
 Radio Control Bees Inc., Larry Whalen, 483 Cliffwood, Brea 92621 R
 RC Bees of Santa Cruz, Inc., W. Boone, 574 Middlefield Dr., Aptos 95003 R
 RC Flyers, D.A. Patton, 14621 Cork St., Garden Grove 92640 R
 RC League of Orange County, R. Heading, 6242 Pricilla Dr., Huntington Bch R
 Redding RC Club, Robert DeGenaro, 6480 Berkeley Dr., Palo Cedro 96073 R
 Redwood Modelers, Blaine Russell, 5028 Maiden Ln., Santa Rosa 95405 F
 Riverside RC Club, Jerry Crowley, 5710 Via Conejo, Riverside 92506 R
 Sacramento Red Barons, J. Sorenson, 3610 Annabelle Ln., Roseville 95678 R
 San Diego RC League, Charles Ramm, 640 Floyd Ave., Chula Vista 92010 R
 San Fernando Valley RC Flyers, J. Replogle, 13939 Burton St., Panorama City R
 San Fernando Valley Silent Flyers, J. Seeley, 20757 Bassett St., Canoga Park R
 San Gabriel Valley RC League, R. Burkhalter, 1211 Oak St., S. Pasadena 91030 R
 San Joaquin RC Modelers, E. Rhoads, 9018 Hillary Lane, Stockton 95205 R
 San Valeers, Walt Prey, 4859 W 97th St., Hillview 90301 F
 Santa Barbara RC Modelers, G. Barnes, 3824 Sterrett, Santa Barbara 93105 R
 Santa Maria Valley Flyers, R. Taube, 869 Sunnyside, Santa Maria 93454 C
 Simi Valley Fliers, Charles Becker, PO Box 3522, Simi Valley R
 Skyburners of Southern Calif., C. Partridge, 12833 Coyote Lane, Norwalk 90650 C
 Sky Hoppers of Orange County, Chuck Ripley, 12321 E. Reva Pl., Cerritos F
 SLO Flyers, Douglas Barton, PO Box 316, San Luis Obispo 93401 R
 Soaring Union of Los Angeles, L. Hart, 2741 W. Washington Blvd. No. 15, Venice R
 So. Alameda County Radio Controllers, D. Shirley, 39723 Plumas Way, Fremont R
 So. Bay Soaring Society, J. Baxter, 3621 Forest Ave., Santa Clara 95050 R
 Southern Calif. Aero Team, Russell Hartill, 7513 Sausalito Ave., Canoga Pk. F
 So. Calif. Antique Model Plane Soc., J. Adams, 2538 N. Spurgeon, Santa Ana F
 So. Calif. Ignition Flyers, Dell Rheumeau, 24231 Hartland, Canoga Park 91304 F
 Speed Flying, Anyone?, F. Kelly, 7005 E. Spring St., Long Beach 90808 R
 Stockton Gas Model Assn., Walter Ghio, 329 Redondo Ct., Stockton 95207 F
 Tokay RC Modelers, Ken Traver, 1700 Mariposa Way, Lodi 95240 R
 Torrey Pines Gulls, R. McDonnell, 10229 Ashwood St. No. 4, Lakeside 92040 R
 The Crash Crew, Joe Schuck, 319 Hanaile Dr., Vista 92083 C
 Thermal Thumbers, Russ Backer, 2705 E. Orange Grove Ave., Orange 92667 F
 Thunderbugs, Reid Libby, 10201 Laramie, Chatsworth 91311 F
 Tracy Skyliners, Robert Holderbein, 124 Laguna, Tracy 95376 R
 Tri Valley RC Modelers, David Jones, 1364 Via Del Carmel, Santa Maria 93454 R
 Tustin Model Club, Dale Willoughby, 14695 Candeida Place, Tustin 92680 R
 Vaca Valley Radio Controllers, J. Wood, 1048 Flickerlane, Fairfield 94533 R
 Valencia Valley Head Winds, James Ross, 25246 Via Sistine, Valencia 91355 R
 Ventura Comets RC Club, Howard Neilson, 132 Genive, Camarillo 93010 R
 Wave Masters RC Club, Ray Wolf, 1458 Husted Ave., San Jose 95125 R
 Willing Able Modelers, Myrtle Coad, 228 Gulp Ave., Hayward 94544 M
 Wing Busters RC Club, Vahan Yeterian, 317 North X St., Lompoc 93436 R
 Woodland RC Club, Calvin Losh, 1036 3rd St., Woodland 95695 R
 900 Club, William Vanderbeek, 459 Woodcock Court, Milpitas 95035 F

COLORADO

Aspen Valley RC Club, Thomas Moore, Box 707, Aspen 81611 R
 Boulder Aeromodelling Soc., Stanley Bush, 4730 Devonshire St., Boulder 80301 F
 Flying Pirates, Thomas Kaster, Box 1711, Aspen 81611 R
 Jefco Aeromodellers, Colton Park, 5312 W. Roxbury Pl., Littleton 80123 R
 Magnificent Mountain Men, G. Larabee, 3203 W. Saratoga Ave., Englewood 80110 F
 Mile Hi RC Club, Donald Atwood, 3042 S. Florence Court, Denver 80231 R
 Model Museum Flying Club, Leslie Payne, 881 S. Josephine St., Denver 80209 F
 Montrose Mini Fliers, Steve Hosner, Box 1174, Montrose 81401 R
 Pikes Peak RC Club, D. Seidel, 911 Maxwell Lane, Colorado Springs 80909 R
 Sky Corral RC Club, John Carpio, 4019 Hillside Drive, Pueblo 81008 R

CONNECTICUT

Bristol Hornets MAC, Charles Piscoski, 196 Circle St., Forestville 06010 C
 Central Ct. Radio Club, Robert Rich, 71 Dogwood Rd., Plainville 06062 R
 Conn. Valley Barnstormers, C. Huszak, 9 Sapphire St., Enfield 06082 R
 County Squire Modelers, Inc., Alex Novotnik, 4 Beverly Pl., Norwalk 06850 R
 East Coast Swamp Flyers Club, J. Scialla, P.O. Box 490, Danbury R
 Fairfield League of Yankee R. Controllers, P.A. Cox, 490, Danbury R
 Flying Aces Club, David Stott, 66 Bankside St., Bridgeport 06606 S
 Glastonbury Aero Modelers, John Schauble, 52 Circle Dr., Windsor Locks 06096 M
 Middlesex Aero Modelers, Harold Dean, Thayer Road, Higganum 06441 R
 Northern Conn. RC Club, A. Guerette, 44 Ridgewood Drive, Rockville 06066 R
 Northeastern Drone Soc. Inc., K. Williams, Apt 3 South Rd., Bolton 06040 R
 Northwest Conn. RC Club, Thomas Francis, RFD 1 Cathole Rd., Litchfield R
 Nutmeg RC Flyers, Anthony Delgobbo, 246 Bucks Hill Road, Waterbury 06704 R
 RC Club of Connecticut Inc., Arthur Fressola, 265 Glenn Dr., Stratford 06497 R
 RC Propbusters, Inc., Henry Struck, RFD No. 2, Lyme 06371 R
 Road Runners RC Club of Conn., R. Hellman, 88 Wilcox St., Bridgeport 06606 R
 Shoreline Miniature Aircraft Assn., J. Nilsson, 24 Homestead Pl., Branford R
 Simsbury RC Club, H.S. Wainaudki, 38 Alder Road, Simsbury 06070 R
 Soc. of Antique Modelers Chapter 7, J. Whittles, 43 Farview Ave., Old Saybrook M
 Trumbull RC Club, Howard Linley, 2068 Huntington Tpke., Trumbull 06611 R
 Valley RC Club, Donald Button, 337 Talmadge Road, Cheshire 06410 R
 Wallingford RC Assn., James Malerba, 38 Hill Ave., Yalesville 06492 R

DELAWARE

Chester County RC Club, R. Walker, RD 2 Faggs Manor Rd., Cochranville 19330 R
 Delaware RC Club Inc., Dr. L.V. Fennoy, 2330 Taggart Ct., Wilmington 19810 R
 Dover Mosquitoes, James DeKlavon, Box 288, Hartly 19953 R
 Flying Blue Hens, George Haak, 410 Hudson Drive, Newark 19711 R

DISTRICT OF COLUMBIA

See Maryland and Virginia listings.

FLORIDA

Aero Modelers of Perrine, W. Phinney, 14771 SW 298 Terr., Leisure City 33030 R
 Aeronuts, Phillip Brown, 1880 SW 9th Street, Miami 33135 C
 Broward County RC Assn., James Maki, 5241 SW 29th St., Ft. Lauderdale 33314 R
 Daytona Beach RC Assn., Jackie Johnson, Box 281, Oak Hill 32759 R
 Ermac Eagles, John Krutz, 76 Kenilworth Ave., Ormand Beach 32074 C
 Fingercrackers, Gerald Ross, 1700 Pontiac Circle, Eau Gallie 32935 C
 Flying Gators MAC, James Rech, 3465 NW 51st Ave., Gainesville 32601 R
 Flying Piranha's, Rocky Knepper, 2387 Demar Dr., Dunedin 33528 C
 Flying Rebels, Herbert Pasch, 2104 Cortez Rd., Jacksonville 32216 C
 Gateway RC of Jax, Richard Mathieson, 1914 Lake Shore Blvd., Jacksonville R
 Gold Coast Radio Controllers, Pete Murphy, 1242 NW 5th St., Boca Raton 33432 R
 Gulf Hawks MAC, Roger Rowley, 1515 26 Avenue N., St. Petersburg 33704 C
 Imperial RC Club Inc., David Hanley, 728 S. Ingram, Lakeland 33801 R
 Indian River Control Soc., Larry Morris, PO Box 238, Grant 32949 R
 Jacksonville FF Team, Francis Carney, 1839 Loyola Dr., Jacksonville 32218 F
 RC Club of Jacksonville, K. Highsmith, 8712 Mathonia Ave., Jacksonville 32211 R
 Manasota RC Assn., Arthur Saxe, 3024 Dividing Creek Dr., Sarasota 33580 R
 Miami Indoor Aircraft Model Assn., J. Martin, 3227 Darwin St., Miami 33133 I
 Miracle Strip Modelers, David Wines, 2864 A Sabre Dr., Tyndall AFB 32401 R
 Moonport Modelers, Boyd Anderson, 4790 Key Madeira Dr., Titusville 32780 R
 NW Florida RC Modelers, R. Hant, 7376 Templeton Road, Pensacola 32506 R
 Palm Beach Aeronauts, Dave Thomas, 3482 Taconic Dr., West Palm Beach 33406 R
 Pensacola Aero Modelers, Tom McLaughlin, 4140 Fern Ct., Pensacola 32503 R
 Remote Control Assn of Central Fl., D. Mott, 122 Fairlane Cir., Sanford 32771 R
 Seminole RC Club, Nic Talantis, 275 John Knox Rd., Tallahassee 32303 R
 SW Florida's Tailspinners, Jim Peters, 2261 Woodland Blvd., Fort Myers 33901 R
 Spaceport RC's Inc., John Titello, 70 Uranus, Merritt Island 32952 R
 Suncoast Aero Modelers Inc., Peter Strayer, 2337 Eastwood Dr., Clearwater R
 Tampa Area Model Pilots Assn., Paul Long, 3617 W. Renellie Cir., Tampa 33609 R
 Tampa RC Aircraft Club Inc., Phil Cota, 4926 E. Broadway, Tampa 33605 R
 Tampa Sky Kings, Charles Stanford, 809 S. Orleans Ave., Tampa 33606 R
 Tropic Aeras RC Club, Marvin Williams, 1975 NW 36 St., Miami 33142 R

GEORGIA

Albany MAC, Frank Watson, 101 Morningside Dr., Albany 31705 R
 Athens MAC, Donald Leyden, 590 Camelot Dr., Athens 30301 C
 Atlanta Drone Society, James Easterday, 3311 Regalwoods Dr., Doraville 30340 R
 Atlanta RC Club, Inc., Gail Jacobson, 2205 Britley Terr., College Park 30349 R
 Atlanta Sky Raiders, E.M. Gillies, 4479 Orleans Court, Chamblee 30341 C
 Coastal Empire RC Society, Van Swindle, 3618 Oakland Ct., Savannah 31404 R
 Cobb County RC Modelers, W.L. Bothwell, 461 Keelerwoods Dr., Marietta 30060 R
 Cobb County Sky Rebels, Bob Stevenson, 209 Sourwood Dr., Marietta 30060 C
 CSRA Flyers, William Fields, 2151 Kingsley Ct., Augusta 30906 R
 Georgia Gnatz, Frank Vitale, 1145B Airman Dr., Robins AFB 31092 R
 Robins Model Flyers, C.J. Manspeaker, PO Box 546, Warner Robins 31093 R
 Savannah Prop Twisters, Joe Vawters, USCG Tybee LTSTA, Ft. Screven 31311 C
 Truannah County Model Flying Club, L. Poole, 120 North Page St., LaGrange 30240 C

HAWAII

Aloha RC Club, Katie Lee, 1407 Kewalo Street 26, Honolulu 96822 R
 Hanalei RC Club, Terry Machado, 775 Waiuanue Ave., Hilo 96720 R
 Hawaii RC Club, W. Fuchsberger, 87-263 Heleuma Street, Waianae 96792 R
 Kapiolani RC Club, Edward Kuramoto, 806 17th Ave., Honolulu 96816 R
 Maui Model Aircraft Club, Damien Pires, RRI, Box 628, Kula Kawaii 96790 C
 Valley Isle Model Pilots Academy, Gordon Carvalho, PO Box 77, Pukalani Maui F

IDAHO

Boise Area RK Society, Jim Ledger, 1703 S. Olympia, Boise 83705 R
 Coeur d'Alene Aeromodelling Soc., C.E. Haught, Rt 2 Box 10, Coeur d'Alene C
 Lewis Clark RC Models, Warren Yardley, 406 30th, Lewiston 83501 R
 Magic Valley Aeromodellers, John Jenkins, 684 Monte Vista, Twin Falls 83301 R
 Palouse Ridge Runners, Dick Jackson, 2504 Deane, Pullman, Wa. 99163 R
 Pocatello Glue Angels, Don Yount, 436 Curte, Pocatello 83201 C

ILLINOIS

Aero Angels, Donald Mosinski, 4241 N. Marmora, Chicago 60634 C
 Aero Bats MAC Inc., Billy Wells, 308 East Elm, Salem 62881 R
 Aero Sport RC Club, Joe Schilling, 521 Sumac Rd., Highland Park 60035 R
 Aero Telemechanics RC Club, John Burns, 827 S. East Ave., Oak Park 60304 R
 Barb City Modelers, Rodney Pluister, 916 Huffman Ct., DeKalb 60115 C
 Belleville RC Flyers, Don Korstad, 5117 Gunn, Scott AFB 62225 R
 Champaign County RC Club, Thad Ellessor, PO Box 100, Urbana 61801 R
 Champaign Urbana Aeronauts, J.J. Fasimpar, PO Box 1004, Tolono 61880 C
 Checkerboard Field RC Club, Carol Zabransky, 6504 W 26th Pl., Berwyn 60402 R
 Chicago Aeronuts, Peter Sotich, 3851 West 62nd Pl., Chicago 60629 F
 Chicagoland RC Modelers, Ed Wargo, 3600 W. Fullerton Ave., Chicago 60647 R
 Chicago Pylon Club, Bruce Balko, 2445 Hamilton Dr., Elk Grove Village 60005 R
 Chicago Scalemasters, Calvin Shumate, 14446 S. Oakley, Blue Island 60406 R
 Columbia RC Club, Morris Schweickhardt, 633 N. Briegel, Columbia 62236 R
 Decatur Aero Commanders RC Club, Jerry Bayless, 1313 W. Main, Decatur 62521 R
 Decatur Blunder Birds, Inc., W. Bomball, 522 W. Division, Decatur 62526 R
 Dekalb Cloud Dusters, Dutch Hess, 137½ E. Lincoln, Dekalb 60115 F
 East Side RC, Harry Ryks, 23 Hampton Drive, Glen Carbon 62034 R
 Flying Aces, Donald Fee, 2311 S. 10th Street, Silvis 61282 C
 Flying Fools MAC, Vernon Blair, 2030 H Illinois Ave., Aurora 60506 R
 Four Knights Flying Team, Al Urban, 248 S. Milton, Glen Ellyn 60137 R
 Fox Valley Falcons, Gary Durham, 24 W. 732 Huntington Circle S., Naperville C
 Fox Valley RC Squadron, Richard Young, 710 N. Edgelaw Dr., Aurora 60506 R
 Freeport Model Air Club, Inc., J. Hainke, 815 W. Hamilton St., Freeport 61032 R
 Illinois Model Aero Club, David Miller, 18017 Wildwood, Lansing 60438 F
 Illinois Valley RC Club, Wayne Sutherland, 1029 5th Street, Princeton 61356 R

(continued on page 112)



Background - AMA/AAM

Approximately 40,000 members of AMA received this magazine as a membership benefit each month in 1972. AMA purchased copies for its members so that they could receive the official AMA News and also the rest of the magazine as a bonus benefit.

Three other model aviation magazines in recent months have published major statements relating to AMA's current arrangement which provides American Aircraft Modeler to members. This, together with the fact that many readers of one magazine also read one or more of the others, suggests that something on the subject should also be said in AAM--for both the AMA members involved and also non-AMA-member readers who may be curious as to what it's all about.

Furthermore, the AMA Executive Council is scheduled to meet on February 17 to decide whether AMA would continue with the present arrangement beyond 1973 or to change to something different. Although it is impossible to say, now, what the outcome of that meeting will be, some background on the subject may be helpful toward understanding whatever is announced later.

Much of the public discussion concerning the current AMA magazine arrangement has claimed that most AMA members would prefer a change, and most mail received by AMA officers seems to confirm this. But the officers are reluctant to go on this evidence alone, on the basis that people more frequently write when they are against something than when they are for it. The following observations from AMA HQ offers evidence that the reluctance of AMA officers may be well founded.

Membership renewals numbering 27,500 were received by AMA HQ in time for the annual December 15 deadline for continuance of magazine service without interruption in 1973. This indicates that most of these people think that the magazine is an important benefit--some might have been concerned with loss of insurance on January 1, but in most parts of the country flying is at a low ebb until spring. Also, AMA election voting ended a month earlier, and only 5,000 participated (out of 15,000 renewals at the time) so voting was not a factor in renewals.

This pattern has been so for several years, even though people prefer not to spend money so close to Christmas. And this year a substantial dues increase was involved. Yet the 1973 membership renewal rate continued ahead of last year's. In addition, over 2,300

new members joined between October 1 and December 15.

It appears that most of these early renewals and new members are not in chartered clubs. For these people the magazine appears to be an important benefit of membership. Non-club AMA members total about 17 thousand--roughly 40% of the entire membership. This large group of non-club AMA members probably makes up the largest group of people basically satisfied with the magazine arrangement--these, plus a significant percentage of club members, since many thousands more members renewed than are in the non-club group alone.

It seems reasonable, therefore, to assume that at least about half of the AMA membership is favorable toward the magazine arrangement. If so, these are the people who have the most to lose if the publication arrangement is changed in 1974. If receipt of the magazine is made optional (one of the possibilities up for AMA Executive Council decision in February) it will be at a higher cost per member: probably 50¢ instead of 30¢ per issue (about \$6.50 per year instead of \$4 as at present, including postage).

If the magazine is discontinued and an AMA newsletter substituted, the cost of membership may be reduced about a dollar per year (\$3 vs \$4 as at present), but the publication package received will be substantially less--8 pages per month vs an average of about 100 pages per month at present (even though only 8 pages at present are "official" AMA News).

The council dilemma is thus considerable. If the membership is split between those who are satisfied and those who are not, the end result can only be a substantial group of unhappy people no matter which way the council decides. As usual in these times on any controversial matter, those responsible for decisions can't win--damned if they do and damned if they don't.

At press time it was hoped that those who are essentially satisfied with the current arrangement will have supported this position by so indicating to their district AMA vice-presidents in time--by the end of January or no later than the first few days of February. Otherwise, the VP's may feel they have no choice but to vote on the basis of responses to date--which have been loudly in favor of a change. This could be a most important crossroads for AMA--if the February Executive Council Meeting changes an arrangement which has been extremely successful in promoting AMA growth for over six years.



Intrepid Bird Men, Carl Audo, 106 S. 6th St., St. Joseph 61873	R
Joliet RC Club, Brian Helmer, 1424 Waverly Place, Joliet 60435	R
Kankakee Valley Model Flyers, Andrew Zoph, Rt. 1 Box 310, Kankakee 60901	R
Kishwaukee RC Flyers, Dale Hindenburg, 1207 Wild St., Sycamore 60178	R
Lake Shore RC Club, Edwin DeVillibus, 3753 Springdale Ave., Glenview 60025	R
Lily Lake Air Knockers, Marlene Morrison, RR 1 Box 218, St. Charles 60174	F
Northwest RC Club, Clarence Fredericksen, 2004 Eastman Ct., Arlington Hts	R
Okav Valley RC Club, Don Seals, 201 Grandview St., Paris 61944	R
Palos Park RC Club, Clifford Hauffaire, 8500 S. Kenton, Chicago 60652	R
Pegasus RC Society, Howard Kusch, 116 Thornhurst Rd., Bolingbrook 60439	R
Prop & Wing Club, Kurt Sunderman, 2303 Grand Ave., Waukegan 60085	C
Quincy Flying Falcons, Lloyd Boden, 705 Monroe St., Quincy 62301	R
Rantoul Prop Busters, James Hilmes, 31 Rose Drive, Rantoul 61866	R
RC Club of Chicago, G.F. Fish, 17730 Cherrywood Lane, Homewood 60430	R
Red Barons MAC, 970 East North West Highway, Mt. Prospect 60056	C
Rockford Aeromodellers, Norbert Russell, 709 Lafayette Ave., Rockford 61107	C
Rock Valley RC Flyers, Kent Miller, 508 27th St., Rockford 61108	R
Silent Order of Aeromodelling, Mitchell Pietraszek, 735 Saylor, Elmhurst 60126	R
Skylarks RC Club of Illinois, R. Swindell, 842-C Colonial Dr., Wheeling 60090	R
Skyknights Aeromodelling Team, C. Winchester, 650 Allanson Rd., Mundelein 60060	R
Sky Squires RC Club, C. Lynes, 177-2 Evergreen Terr., Carolandale 62901	R
Springfield Sunday Flyers RC Club, Inc., D. Waibel, 2136 Pickett, Springfield	R
Suburban Aeroclub of Chicago, G. Pardee, 815 Hodges, Beecher 60401	R
Thorn Creek RC Club, R. Mattson, 14732 S. Dorchester, Dolton 60419	R
Tree Town Model Aires, Inc., T. Jones, 18W 096 16th St., Villa Park 60181	C
Tri City Sky Steelers, John Blum, 2417 Glen Place, Granite City 62040	C
Tri Village RC's James Cywinski, 725 Russett Lane, Streamwood 60103	R
West Suburban RC's, Joe Antunes, 303 E. Myrick Ave., Addison 60101	R
Woodland Aero Modelers, Karl Zerbe, 7616 Woodridge Drive, Woodridge 60515	C



INDIANA

Columbus Model Club, Russell Kuhn, PO Box 1372, Columbus 47201	R
Converse RC Flying Club, Jerome Rosman, 226 E. 50th Street, Marion 46952	R
Dekalb Flying Model Club, William Snavley, 416 W. 9th St., Auburn 46706	R
Eastern Ind. RC Assn., Joe Fallon, 1720 East Main St., Richmond 47374	R
Evansville RC MAC, Carl Jarvis, 1628 E. Blackford, Evansville 47714	R
Ft. Wayne Flying Circuits, W.W. Weber, 2022 Kensington Blvd., Ft. Wayne 46805	R
Griffith Barnstormers, Andi Wright, 231 N. Jay, Griffith 46319	C
Hamilton Flying Modelers, Paul Bennett, 5745 Susan Drive East, Indianapolis	R
Ind. RC Modelers, Robert Godfrey, 7605 S. Belmont Rd., Indianapolis 46218	R
Ind. RC Prop Busters, C. Levenzer, 622 Turtle Creek N. Dr. No. 9, Indianapolis	R
Ind. West Side RC Modelers, F. Feeney, 5302 N. Delaware St., Indpls. 46220	R
Indy Sportliners, Paul Patterson, 1943 Calhoun Court, Indianapolis 46203	C
Kokomo Blew Angles RC Club, Gary Snyder, 1708 Stoneview Dr., Kokomo 46901	R
Lafayette Cloud Jockeys, Ralph Ramsey, 223 Main St., Lafayette 47901	R
Lapel Flying Modelers, Bill Ellis, 287 W. 18th Street, Anderson 46011	R
Lebanon Aeromodellers, Raymond Padgett, RR No. 2, Ratsburg Rd., Lebanon 46052	R
Logansport Thunderbirds, Charles Wiles, RR 5 Box 306, Logansport 46947	R
Madison County RC Flyers, Jerry Payton, 601 W. Washington, Alexandria 46001	R
Marion Model Menders, Charles Vermillion, 2157 W. 8th, Marion 46952	C
Midwest Sundowners Flying Club, G. Nordmann, 380 W. Midway Dr., Valparaiso	R
Monroe County RC Club, Dennis Freisel, RR 8 Shields Ridge Rd., Bloomington	R
Muncie Controliners, Dick Ramsey, 1007 W. Race St., Portland 47371	C
Munsee Skychiefs RC Club, Larry Smith, RR 13 Box 304, Muncie 47302	R
Northern Ind. Model Aeronautics Assn., K. Bunting, 1306 McArthur, Munster 46321	R
Pelican MAC, Timothy Banaszak, 1947 Superior Ave., Whiting 46394	F
Screaming Eagles RC Club, David Bloomer, 54 S. Cross St., Danville 46122	R
Southern Ind. RC Club, R. Howard, 3303 Deerwood Dr., New Albany 47150	R
Tri County Aero Club, Ross Woods, 219 South 5th St., Vincennes 47591	R
Tri Valley RC, Norma Stewart, 1142 E. Altgeld St., South Bend 46614	R
Wabash Valley RC Club, Buford Gross, 10 N. Canal St., Peru 46970	R
Warsaw Aero Modelers, Jerry Kay, 903 E. Benton, Winona Lake 46590	R
White Water Valley RC Club, David Herrick, 105 Ridge Rd., Connersville 47331	R

IOWA

Balsa Busters, D.K. Hutcheson, 317 Spencer Ave., Council Bluffs 51501	C
Blackhawk RC Pilots Inc., W. Boots, 211 Hillside, Waterloo 50701	R
Burlington MAC, Robert Meuler, 1400 Parkway Drive, Burlington 52601	M
Castor Oilers, John Brown, 2330 Southview Dr., Bettendorf 52722	C
Cedar Rapids Skyhawks, G. Hammond, 2195 Northview Dr., Marion 52301	R
Davenport MAC Inc., Richard Mairet, 3009 Westmar Dr., Bettendorf 52722	C
Des Moines Modelaires, Thomas Dorman, 441 SE Marion, Des Moines 50315	R
Dodger RC Club, Ernest Milenberg, 1278 7th Ave. North, Ft. Dodge 50501	R
Hawkeye Model Aviation, Randolph Hill, 203 12th Ave., Hiawatha 52233	C
Iowa City Aero Hawks, Terry Edmonds, Rt. 6 Box 194A, Iowa City 52240	R
Model Mangles of Iowa, William Miller, 2417 47th St., Des Moines 50310	C
Muscatine RC Unlimited, Kenneth Morris, 404 Park Ave., Muscatine 52761	R

KANSAS

Capitol City RC Club, Ted Glenn, 925 Cambridge, Topeka 66606	R
Central Aeromodellers Soc., James Kraft, 1707 Jenkins, Marysville 66508	R
Hi-Plains RC Club, Fred Casterline, 905 Arapahoe, Dodge City 67801	R
Jayhawk Model Masters, Paul Erhart, 3232 Iowa, Lot 252, Lawrence 66044	R
Johnson County Aeromodellers, William Marsh, 8880 Farley, Overland Park 66212	C
Kansas Sunflyers, Bill Ryan, RR 1, Great Bend 67530	R
Mid America RC Soc., Leon Gehrke, 215 Main, Delphos 67436	R
Shawnee Mission RC Club, David Ellis, 8301 W. 92nd St., Overland Park 66212	R
Wichihawks, Roger Smith, 1510 Haskell, Wichita 67213	C
Wichita RC Club, Jim Slaughter, 2278 S. Pincrest, Wichita 67218	R

KENTUCKY

Bardstown Aero Modelers, Jimmie Brooks, 116 S. Center, Bardstown 40004	C
Central Kentucky RC Club, Harold Downing 2993 Montavesta Rd., Lexington 40502	R
Confederate RC Air Force, Bert Dionne, 1030 Stevenson Rd., Erlanger 41018	R
Knox MAC, Edward Hall, 5657 B Corley St., Fort Knox 40121	R
Lexington MAC, Edwin Paul, 1640 Marwick Dr., Lexington 40504	C
Louisville RC Club, Inc., George Wade, 4428 Lynnbrook Dr., Louisville 40220	R
Paducah Aero Modelers, Robert Hobbs, 3950 Phillips Ave., Paducah 42001	R
Southern Kentucky RC Club, Ronald New, RR 2 Box 345, Somerset 42501	R
Syntonic Aero Club, Don Robinson, 110 Valley View, Southgate 41021	R

LOUISIANA

Acadian RC Club, J.C. Huff, 441 Glynndale Street, Lafayette 70501	R
Chalmette RC Club, Ernest Grass, 3001 Volpe Dr., Chalmette 70043	R
Dyna Soarers MAC, Albon Seither, 7520 Weaver Ave., New Orleans 70127	R
Northeast La. RK Society, Louis Scott, RT 5 Box 174A, Winnboro 71295	R
Shreveport Area RC Soc., Patrick Osborne, 1617 Dudley Ln., Bossier City 71010	R
Shreveport Sky Demons, J.M. Norwood, 9370 Jessica, Shreveport 71106	C
Tri Parish RC Club, Barry Bleakley, 463 Oak St., Norco 70079	R

MAINE

Kennebec Valley RC Club, Edward Tebolt, 2 Patricia Terr., Waterville 04901	R
Moosehead Bushpilots RC Club, Axel Kurth, Airport, Greenville 04441	M
Proprsnappers Inc., Howard Kennedy, RFD No. 3, Gorham 04038	R
RC Sport Modelers, Murlyn Greenleaf, 173 Oak Street, Bath 04530	R

MARYLAND

Aeromasters MAC, William Firesheets, Rt. 1 box 199D, Severna Park 21146	C
Baltimore Aero Craftsmen MAC, H. Weil, 3606 Monterey Rd., Baltimore 21218	F
Baltimore MAC Soc., R. Reckling, 6744 Townbrook Dr., Apt. E, Baltimore 21207	R
Charles County RC Club, Robert Perry, 8703 Clarion Ct., Washington, DC 20022	R
Chesapeake Bay RC Club, Gordon Chambers, 1133 McHenry Dr., Glen Burnie 21061	R
Cumberland Aircraft Model Soc., O. Striely, 949 Nottingham Pl., LaVale 21502	R
DC Maxcutters, John Thornhill, RFD 1 Box 85A, Mt. Airy 21771	F
DC/RC Inc., Lee Minin, 4827 Polk Ave., Alexandria 22304	R
Flite Streaks Model Club, G. Weber, 1737 Leslie Rd., Baltimore 21222	C
Frederick MAC, Inc., John Patton, Rt. 5, Frederick 21701	R
Meade Modelers MAC, Walter Cisko, 575 Rita Dr., Odenton 21113	R
Mid Atlantic RK Soc., Fred Kerstetter, Center Dr., Ocean City 21842	R
Pegasus RC MAC, David Spessard, RFD 3, Smithsburg 21783	R
Prince George RC Club, James Turner, 3410 Village Dr. N, Upper Marlboro	R
RC Modelers of Baltimore, James Green, Box 116 Rt. 2, Phoenix 21131	R
Sky Lancers of Washington DC, Price Reece, 6874 Riverdale Rd., Lanham 20801	C
So. High School MAC, Carl Johnson Rt. 1 Box 309, Deale 20751	C
Suburban Maryland MAC, Raymond Vojtko, 17124 Downing St., Gaithersburg	R
Westminster Aero Modelers, R. Pease, 65 E. Main St., Westminster 21157	R

MASSACHUSETTS

Berkshire CL Flyers, James Armstrong, 104 Bromback St., Pittsfield 01201	C
Berkshire RC Flying Club, John Czarnecki, 127 North St., Windsor 01270	R
Cape Ann RC Model Club, Robert Gaertner, 9 Brookbridge Rd., Peabody 01960	R
Charles River RC's, R. Davis, 45 Auburn St., Apt. 2, Framingham 01701	R
Chelmsford RC Modelers Club, T. Shipko, 113 Grantville Rd., Chelmsford	R
Hampshire County R Controllers, R. Yarrows, 5 Moody Bridge Rd., Hadley 01035	R
Merrimack Valley Air Istocrats, Elvin Bowe, 101 S. Riverview St., Bradford	M
New England Aero Team, Frank Baptista, 172 Coffin Ave., New Bedford 02746	R
New England RC Modelers, Gary Garabian, 497 Central Ave., Seekonk 02771	R
New England Wakefield, Stanley Colson, 47 Sammet St., Everett 02149	F
Northshore Model Aircraft Assn., D. Reagan, 6 Ridgeway Ct., Lynn 01902	R
Pioneer Valley RC Club, Bruce Bentley, 230 White St., Springfield 01108	R
Precision Modelers Assn., Paul Wilson, 25 Huntington Ave., Boston 02116	R
Quinapoxet Model Flying Club, Edward Eaton, 910 Wachuset St., Holden 01520	R
South Shore RC Club, Warren Shadrick, 38 1/2 Warren St., Randolph 02368	R
Springfield Area Radio Kontrolers, W. Sargent, 288 Circle Dr., W. Springfield	R
Valley Thunderbirds, Bernard Gaudette, 155 Elm St., E. Longmeadow 01028	C

MICHIGAN

Aero RC Club Inc., John Ibbotson, 3502 Fenton Rd., Flint 48507	R
Ann Arbor RC Falcons, Durwood Sagvold, 804 Valley Circle Dr., Saline 48176	R
Battle Creek Balsa Bees MAC, J. Watters, 31 W. Minges Rd., Battle Creek 49017	C
Brighton RC Club, John Resh, 6501 Forest Beach Dr., Brighton 48116	R
Capital Area Radio Drone Squadron, C. Spencer, 236 Theo St., Lansing 48917	R
Detroit Balsa Bugs, Inc., W. Hartung, 14759 Kilbourne Ave., Detroit 48213	F
East Wings Model Club, Ronald Logghe, 1940 Shadowoods Dr., Roseville 48066	R
Flying Lancers, Gregory Baggerly, 5874 Saint Joseph Ave., Stevensville 49127	R
Flying Robots, Alfred Heien, 29600 Hathaway, Livonia 48150	R



Flying Wolverines, Calvin Satawa, 31117 N. River Rd., Mt. Clemens 48043	R
Greater Detroit Soaring & Hiking Soc., E. Pell, 907 Melford, Rochester 48063	R
Greater Flint RC Club, Inc., Clark Mahan, 4120 Le Erda, Flint 48504	R
GRIMES, Charles McLanis, 2627 Hillside Dr. NW, Grand Rapids 49504	F
Indian City RC Club, Albert Winters, 15336 Grandville, Detroit 48223	R
Jackson RC Club, Manville Wilson, 7146 Bay View RFD 6, Jackson 49201	R
Kent Radio Aero Modelers, Robert Kok, 5186 Pleasant Creek NE, Comstock Pk	R
Lansing Flying Aces, Robert Smith, 908 W. Shiawassee St., Lansing 48915	C
Livonia Rib Crackers, Robert Casler, 11309 Blackburn, Livonia 48150	R
Michigan RC Society, Gordon Pearson, 8232 Farhart Rd., South Lyon 48187	R
Midwest RC Society Inc., J. Wernersbach, 21727 E. Valley Woods Dr., Birmingham	R
Pontiac MAC, Roy Pinner, 3955 Lotus Dr., Waterford 48095	R
RC of Detroit, Fred Field, 8742 Chalmers, Warren 48093	R
Roseville Whirlybirds, John Terrell, 28903 Waverly, Roseville 48066	F
Saginaw Valley RC Club, Richard Watz, 2623 S. Miller, Saginaw 48603	R
Seaway RC Club, Russell Price, 4725 Hts. Ravenna Rd., Fruitport 49415	R
Signal Seekers RC Club, Wayne Yeager, 6323 N. Wayne Rd., Westland 48185	R
Strathmoor Model Club of Detroit, L. Rytksaryk, 7787 Archdale Ave., Detroit	C
Saginaw Sodbusters Model Club, J. Rittenberry, 3309 Osler St., Saginaw 48602	C
Thunderbirds-Battle Creek MAC, H. Lindsay, 126 N. 32nd St., Battle Creek 49015	R
The VII RC Club, Mel Kleist, 20857 Shoreview, Mt. Clemens, 48043	R
UP Model Aeronautics Assn., J. Ponniti, 1010 N. 2nd Street, Ishpeming 49849	C
West Godwin Hobbies RC Flying Club, Frank Pulte, 1545 Iowa St. SW, Wyoming	R

Whirlwinds of SW Michigan, G. Wolfram, 377 S. Church St., Coloma 49038 R
Ypsi Hobby Club, Frank Trovinger, 33079 Alanson Ave., Westland 48185 C

MINNESOTA

Central Minn. Radio Controllers, Ken Bentz, 1910 10th Ave. S, No. 4, St. Cloud	R
Elk River RC Club, John Olmstead, 1840 8th St., Elk River 55330	R
Golden Eagles Flying Club, Fred Rilling, Box 369 Rt 3, Alexandria 56308	C
Mankato Modelers, Dave Osoda, 120 Ridge Lane, Mankato 56001	C
Minn. Model Aero Club, Larry Stockstad, 2648 Carlson Dr., Coon Rapids 55433	F
Minn. Piston Poppers, Peter Simonson, 2520 Parkway Blvd., Minneapolis 55422	C
Rochester Aero Model Soc., W. Wentink, PO Box 6163, Rochester 55901	R
St. Paul RC Model Club, Peter Stapleton, 5548-27 Ave. S., Minneapolis 55417	R
Twin City Radio Controllers, Louis Painter, 11408 Kell Rd., Bloomington 55437	R
Viking Land RC Flyers, Dan Tuseth, 115 7th Ave. S., Crookston 56716	R

MISSISSIPPI

Capital City RC Club, Mike Marshall, 5906 Westmore Dr., Jackson 39206	R
Columbus Prop Busters, Jim Wright, 7416 A Salem Dr., Columbus AFB 39701	R
Magnolia Flyers, Paul Dickson, PO Box 1764, Hattiesburg 39401	R
Meridian RC Club, Julie Woods, PO Box 127, Scooba 39358	R
Singing River Modelers, Nathan Davis, 3307 Basswood, Pascagoula 39567	R
Yazoo RC Club, W.H. Harvey, 1024 Jackson Ave., Yazoo City 39194	R

MISSOURI

Freelancers RC Club, R. Stagner, 1838 Seifert Dr., Poplar Bluff 63901	R
Hot Heads MAC, Inc., William Reeh, 10821 St. Xavier Ln., St. Ann 63074	C
Joplin RC Model Club, Jim Hefley, 3305 Garrison, Joplin 64801	R
Kansas City RC Club, Fred Hulén, 4915 Wallace, Kansas City 64129	R
Kansas City Super Tigers, Dave Trible, 7201 E. 104th, Kansas City 64134	C
Kirkwood Thermalers Inc., Robert Hotze, 673 Craigwoods Dr., Kirkwood 63122	M
Lafayette Esquadrière, August Vogele, 703 Connie Ln., Manchester 63011	M
McDonnell FF Club, James Bennett, 324 Helfenstein, St. Louis 63119	M
McDonnell RC Club, Carlos Bedoya, 1127 Ford, Ferguson 63135	R
Mid Missouri RC Assn., Jennifer Webb, Box 475, Columbia 65201	R
St. Charles Phantom Flyers, Ed Gross, 431 Vine St., O'Fallon 63366	C
St. Joseph RC Club, Richard Drozed, 2401 Big Pine Terrace, St. Joseph 64503	R
St. Louis Yellow Jackets Inc., A. Schaefer, 4206 Virginia Ave., St. Louis	C
Signal Chasers, Melvon Hart, 936 Dontaos Dr., St. Louis 63131	R
Sky Devils of Kansas City, Walter Garrett, 917 Allen, Independence 64050	C
Spirits of St. Louis, James Zamboni, 8838 Lucas-Hunt Rd., Jennings 63136	R
Springfield Balsa Busters, R. Albaugh, 834 Swan St., Springfield 65804	C
Springfield RC Club, Daniel Curtis, 1523 S. Holland, Springfield 65804	R
Sunchasers RC Club, Gilbert Frahm, 6609 Quail Run Dr., Kansas City 64152	R

MONTANA

Big Sky RC Modelers, Richard Helgeson, 612 3rd Ave. SW, Great Falls 59404	R
Billings Flying Mustangs, Dale Cowger, 1246 Miles Ave., Billings 59102	R
Blue Mountain Aero Modelers, David Rankin, 1738 W. Kent, Missoula 59801	R
Bozeman Air Tragedy Soc., Charles Curtis, 1202 Spruce, Bozeman 59715	R
Cut Bank Sky Hawks, Edward Krona, 204 Park Ave., Whitefish 59937	R
Helena Flying Tigers, Floran Higgins, Birdseye Rt., Helena 59601	R

See April issue (next month) for Clubs in Nebraska, Nevada, New Jersey, New Mexico, New York, North Carolina, North Dakota, Ohio, Oklahoma, Oregon, Pennsylvania, Rhode Island, South Carolina, South Dakota, Tennessee, Texas, Utah, Virginia, Washington, West Virginia, Wisconsin, Wyoming, APO and foreign.

Rules-Change Proposal Forms Now Available

The standard form for submitting proposals for AMA competition model rules changes (with 1974 effectivity) may be obtained by sending a request accompanied by a pre-addressed stamped (8 cent) envelope to AMA HQ, 806 Fifteenth St., N.W., Washington, D.C. 20005. All proposals to be considered by the AMA Contest Boards must be submitted on this standard form.

The rules Change Proposal Form is applicable to all kinds of AMA competition rules: General, Free Flight, Control Line, Radio Control, Scale. In completing the form the proposer must provide (1) a brief summary of the proposed change, (2) the exact wording proposed for the rule book, (3) the logic behind the proposal change, including alleged shortcomings of the present rules, and (4) the proposer's signature and AMA number plus endorsement by signature and AMA number of two other members; all must be adult AMA members, and at least one must be a current AMA Contest Director.

Proposals should be submitted as soon as possible, but must reach AMA HQ on the

standard form no later than April 1, 1973, if they are to be acted upon for possible inclusion in the 1974-5 rule book (remember that the Executive Council also approved a two-year cycle for rules changes).

Contest Calendar

Official Sactioned Contests of the Academy of Model Aeronautics

FEB. 3-4—SAN DIEGO, CALIF. (AA) Southern California CL Association Annual CL Meet. Site: N. Island Naval Air Station. C. Johnson CD, 2384 Ivy Rd., Oceanside, Calif. 92054.
FEB. 4—GREEN BAY, WISC. (A) Polar Bear FF (Cat. II) Meet. Site: Frozen Green Bay. R. Cowles, Jr. CD, 2424 Ducharme Ln., Green Bay, Wisc. 54301.
FEB. 11—GRAND JUNCTION, COLO. (A) Modelers Annual Indoor Meet. Site: Grand Junction. W. Hoaglund CD, 2803 Mesa, Grand Junction, Colo. 81501.
FEB. 11—MIAMI, FLA. (A) Dade Park & Recreation Indoor (Cat. I) Contest. Site: Youth Fair. B. Myers CD, 3935 SW 125th Ave., Miami, Fla. 33165. Sponsor: M.I.A.-M.A. Club.
MARCH 18—MIAMI, FLA. (A) Dade Park

& Recreation Indoor (Cat. I) Contest. Site: Youth Fair. B. Myers CD, 3935 SW 125th Ave., Miami, Fla. 33165. Sponsor: M.I.A.-M.A. Club.

MARCH 18—LIVINGSTON, N.J. (A) Livingston Flying Tigers CL Air Races. Site: G-V Controls. C. Schaefer CD, 514 N. Chestnut St., Westfield, N.J. 07090.

MARCH 31—LOCUST VALLEY, L.I., N.Y. LIAMAC Indoor (Cat. I) Record Trials. Site: Friends Academy. J. Paillet, CD, 30 Emerson Rd., Brookville, L.I., N.Y. 11545.

APRIL 15—DAYTON, OHIO (A) Spring CL Fly-In. Site: Dayton. J. Haupt CD, 3908 Necco Ave., Dayton, Ohio 45406.

APRIL 15—MIAMI, FLA. (A) Dade Park & Recreation Indoor (Cat. I) Contest. Site: Youth Fair. B. Myers CD, 3935 SW 125th Ave., Miami, Fla. 33165. Sponsor: M.I.A.-M.A. Club.

APRIL 21-22—DAYTONA BEACH, FLA. (AA) Eagle-Beagle CL Model Airplane Contest. Site: Daytona Beach. H. Lambert CD, 109 Old Carrage Rd., Daytona Beach, Fla. 32019.

APRIL 28-29—FT. WORTH, TEX. (AA) 3rd Annual RC "Lone Star Airobatic Convention." Site: Benbrook Lake. L. Stanfield CD, 1813 Montclair, Ft. Worth, Tex. 76103.

APRIL 29—CINCINNATI, OHIO (A) CL Combat Bash. Site: Lunken Airport. W. Messerly CD, 1122 Eight Mile Rd., Cincinnati, Ohio 45230. Sponsor: Queen City U-Control Club.

APRIL 29—HILLSBORO, ORE. (A) Nor-Westers Spring FF (Cat. II) Contest. Site: Hillsboro. D. Sobala CD, 1720 NW 138th Ave., Portland, Ore. 97229.

QUALITY HOBBY SHOPS

Quality Hobby Shop spaces are sold on a six-month basis at \$7.00 per month, payable in advance. All insertions must be consecutive. No mention of mail-order business is permitted. Closing Date: 10th of third preceding month.

WEST VIRGINIA—PARKERSBURG
Planes-R/C and Control Line, Engines and Accessories. All kinds of Goodies! Kraft Radios, Sig Products, Lionel Trains. Also HO and N gauge trains and accessories. HO slot track in stock. HO slot cars and parts. Craft and Hobby supplies.

WILSON HOBBY SHOP
Park Shopping Center, Parkersburg, W.Va.
26101 1-304-428-0713

OHIO—CLEVELAND
We carry the most complete line in Ohio for your model airplane hobby. Also large HO train dept., Boats, R/C, motors, parts, supplies, dope, balsa, tools, books, magazines, etc.

NATIONAL HOBBY, INC.
5238 Ridge Road (216) 749-4750

MASSACHUSETTS—CAMBRIDGE
Model planes, motors, railroads, ships, radio control equipment and accessories—also slot racing supplies. Open 9:00 AM to 5:30 PM daily & Thurs. evenings.

CROSBY'S HOBBY CENTRE
1704 Massachusetts Ave. (617) 547-4389

NEW JERSEY—IRVINGTON
The oldest established hobby shop in New Jersey. Everything in trains, ships, planes and rocketry. Hours 10 to 7 daily, 10 to 1 on Sunday.

THE HOBBY SHOP
758 Springfield Ave. (201) 372-6211

PORTLAND—OREGON
Portland's Headquarters for Radio Control Equipment, all major brands all at discount prices. "Shop American," "The Friendly Shop."

AMERICAN PET & MODEL AIRPLANE SUPPLY COMPANY
4308 S.E. King Rd. in the Disco Mart shopping center. Ph. 654-8777 Zip: 97222

SOUTH CAROLINA—BEECH ISLAND
Three miles from Augusta, Georgia. Headquarters for Radio Control equipment. Kits - motors - retractable gear - fuel. All kinds of accessories for R/C and U/C Building of Kits. Ready built planes always in stock. We help you build and fly. Open 9:00 A.M. till 11:00 P.M. plus Sundays till 10:00 P.M.

MILLER'S HOBBY SHOP
315 Laurie Dr. 803-822-0565

COLON, REPUBLIC OF PANAMA
The only hobby shop in the country. Model Planes, Motors (radio controlled), ships, H.O. and N. Gauge trains, complete stock of parts and accessories.

KELNIA S.A.
Front Street, Colon, P.O. Box 2086, Zone 3, Telephone, 47-7040. Warehouse in the Free Zone of Colon.

MICHIGAN—DETROIT (FERNDAL)
Trains, planes, stamps, coins, R-ways. Over 50,000 items for hobbyists. Mich. largest antique train collection. Look for our 55' RR crossing sign. Arnold Rapido.

MODELS HOBBY CENTER
22524 Woodward Ave. (Zip 48220) LI-3-2242

GEORGIA—DECATUR
HO Railroads, Planes, Model Car Racing. Open 11 AM to 10 PM. Metro Atlanta's Friendly hobby shop.

HOBBY HOUSE
DECATUR SPEEDWAY
130 E. Ponce de Leon 378-2253

HONG KONG—KOWLOON
The most complete stock of aeromodelling and hobby supplies in the Far East. Sole agents for Graupner, O.S. and Min-X and agents for Vernon, Frog, Solarbo and many others.

RADAR CO., LTD.
2 Observatory Road Kowloon, Hong Kong K-680-507

AVONDALE ESTATES, GEORGIA
Southeastern factory repair center for Micro Avionics and Orbit systems. Complete stock of parts. All work guaranteed. Parts in stock for Blue Max and most systems. Authorized

factory service center for Testors planes and radios.

HOBBY DISTRIBUTORS
4 Avondale Road, P.O. Box 102,
Avondale Estates, Georgia 30002

ALABAMA—BIRMINGHAM
If it's hobbies, we have it. Most complete line in Southeast. Model airplanes, motors, trains, slot cars, Radio Control equipment—cars, planes, boats and accessories.

SPIVEY DISCOUNT
1303 Tuscaloosa Ave. 205-785-9690

RHODE ISLAND—PAWTUCKET
Radio Control, Model Planes, Motors, Ships, Rocketry, Arts Crafts, Slot Racing, Parts and Accessories, H.O. & N Gauge Trains, Open 6:30 P.M. to 10:00 P.M. Daily & Saturdays 12:30-5:00 P.M.

R & M HOBBIES
81 Columbus Avenue (Zip 03860)
(401) 728-4320

OHIO—JAMESTOWN
Radio Control Specialist. Have done professional building and consultation for research work. Retail stock consists of Radios, Engines, Mufflers, Kits (Arf. & Balsa), R.C. Helicopter Kits & most support items for R.C. Discount prices. 15 years experience at your service. 6-10 Eve. 10-6 Sat.

MID-OHIO RADIO CONTROL
3949 N. Lake Shore Drive 513-675-2613

VIRGINIA—ARLINGTON
Washington D.C. Area? Try us First! Model aircraft, R/C, U/C, F/F., R/C Cars, boats, engines, accessories, equipment, publications, tools, unimat lathes and parts. Hours: Mon, Thurs, Fri: 10-9, Tues and Sat: 10-6.

ARLINGTON HOBBY CRAFTERS
625 N. Glebe Rd., Arlington, Va. 22203
522-6442

SOUTH CAROLINA—NEAR BOWMAN
Located on Road 36 just off I-26. Complete U-Control Center on 12-acre flying field. Big Discounts! Open 4 to 8 weekdays and all day Saturdays. Plenty of help for beginners. Flying every Sunday afternoon.

ACTION HOBBIES MODEL AIRPORT
Route No. 1, Box 53AB Bowman, S.C. 29018

MEXICO—MEXICO CITY
The most complete stock of aeromodelling and Radio Control supplies in Mexican Republic.

Factory authorized Kraft System, Pro Line System, Webra and H.P. Engines. Sales and Service center, all best items and the best prices.

We accept Bancomatic & Bancomer Cards.
MATHELIN MODELISMO
Retorno 3 DeGral. Ignacio Zaragoza No. 47
Mexico 9, D.F. Tel: 5-71-75-07

COLORADO—COLORADO SPRINGS
Complete line of U-Control, Free Flight and Engines. Headquarters for R/C. We feature Royal Classic, Lee Engines, Sig Products. Master Charge, Discount to AMA Members. "We Fly What We Sell."

CUSTOM HOBBIES
2408 E. Platte Ave., Colorado Springs,
Colo. 80909 (303) 634-7400

NEW MEXICO—ROSWELL
Radio control specialists serving the Southwest with all major brands of R/C equipment. See us for discount prices on kits, engines, radios, and any other supplies you might need.

AIRPORT R/C MODEL DEALERS
P.O. Box 387, Roswell, New Mexico 88201
AC 505 - 623-5734 or 622-4817

CLASSIFIED ADS

Rates: 30¢ per word (including name and address). Minimum—14 words. Send remittance with copy and order to: **AMERICAN AIRCRAFT MODELER**, 715 Fifteenth St., N. W., Washington, D. C. 20005.

ARE YOU TIRED OF PLANES? Start racing cars! Send 25 cents for accurate updated information. **R/C CARS INTERNATIONAL**, 3314 Firestone Blvd., South Gate, Calif. 90280 USA

NO MORE PROBLEMS to clean oily airplanes. Use our highly concentrated "ZIF" - delute with water. Instructions included. 1/4 gln \$2.80 plus \$1.00 postage/handling. W. WICHA - 1528 Northgate Sq., Reston, Va. 22090.

CUTTING TOOLS—Precision tools, mills, reamers, dial callipers, more. Catalog 25 cents. **RED, WHITE & BLUE Company**, P. O. Box 345, Goodyear, Arizona 85338.

FIRST NEW 1/4 x 32 Spark Plugs to be manufactured in 25 years. Available soon new 29 Ignition engine. Super Cyclone and Anderson Engines. List 25 cents. **REMCO**, P. O. Box 22414, Denver, Colorado 80222.

HAND CUT KITS: Beautiful Velle Mono-coupe, rubber powered \$7.95, plans \$2.25. The J3 Cub, 1/4A R/C or FF Kit \$14.95, plans \$3.00. Stamped envelope brings photo sheets from Flyline Models, 10643 Ashby Place, Fairfax, Va. 22030.

CASTLE LION HOBBIES WEBRA 61RC \$61.95, MRC 3Ch - 27 MHZ \$135.95, 5Ch - 27 MHZ \$249.95, 72 MHZ - 5Ch \$266.75, Connecticut residents add 7% tax. No personal checks. Add \$2.00 postage & handling. P. O. Box 635, Branford, Conn. 06405.

LARGEST SELECTION of Super Tigres in the U.S. G 15 RV Diesel \$25.25, G 15 FI \$21.25, G 15 FI RC \$25.25, 23 RC \$20.50, 35 Combat \$17.25, 35 RC \$21.25, G29 RV ABC \$27.95, Discount prices on Super Tigre and Max engines and parts. New Max 40 RC \$27.95, Max 15 RC \$17.25, Wankel 30 RC \$70.75, many others. Postpaid. **DON'S SALES & SERVICE**, P.O. Box 224, Ft. Thomas, Ky. 41075.

QUITTING RC. Send for list of new and used RC Equipment including 5 6 meter two stick propo rigs, kits, engines, balsa wood, much else. **JACK MATHIAS**, 721 S. Meadow Rd., Evansville, Indiana 47715. Area Code 812-477-2516.

WORLD WAR II R/C SCALE PLANS \$5.95 each. 6 1/4" P-47D, 6 1/2" Skyrider, 60" Stuka, 63" Mosquito, 62" Zero, 60" Hurricane, 56" Gloster Gladiator, 69" SBD 5 Dauntless \$7.50, 60" Vulcan Delta \$6.95. Canopies, Fibre-glass cowls or complete kits also available. 25 cents for illustrated catalog. **BUD NOSEN'S SCALE SALES**, Box 105A, Two Harbors, Minnesota 55616.

SPEED DOLLIES, also aluminum dolly wheels and Flynn Rat gear. **WALTER BRASSELL**, 4361 Montview Dr., Chattanooga, Tenn. 37411.

BIG SAVINGS! Complete line of R/C & U/C accessories. (Rev-up) props 7/4 to 14/6. Cos. S.T., O.S., Fox, K&B engines in stock. K&B Schn, 15 R/C \$29.95, O.S. .25 R/C \$19.95, Fox 36X \$12.95, Falcon 56 \$15.95, Dubro Sea Bird \$42.95, Goldberg Shoestring \$6.95 and Devcon 2 1/2 Oz. \$1.89. Just a sample of many items in stock. Postage paid on orders over \$50.00. Send for free price list. **B&N HOBBY CENTER**, 5200 Rye Drive, Dayton, Ohio 45424.

SCALE R/C PLANS. GRUMMAN TBF-1C* 61", HELLCAT F6F-5* 54", RYAN FR-1 FIREBALL* 60", BOEING F4B-4 53", GEE BEE R-1 50" \$5.50 per set. BOEING B-17G* 78" \$9.50 set. *Measured from actual aircraft. Detailed brochure 20 cents. **AER-O-SCALE**, P.O. Box 3413, Granada Hills, Calif. 91344.

Crippling can strike anyone at anytime...

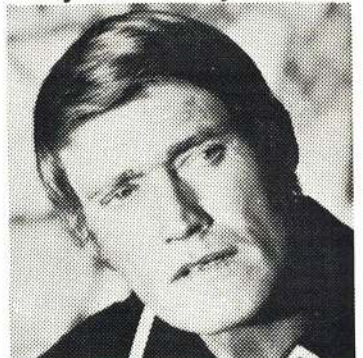

CHUCK CONNORS

**Help those stricken.
Give to Easter Seals
March 1 - April 22**

7

series seventy-three

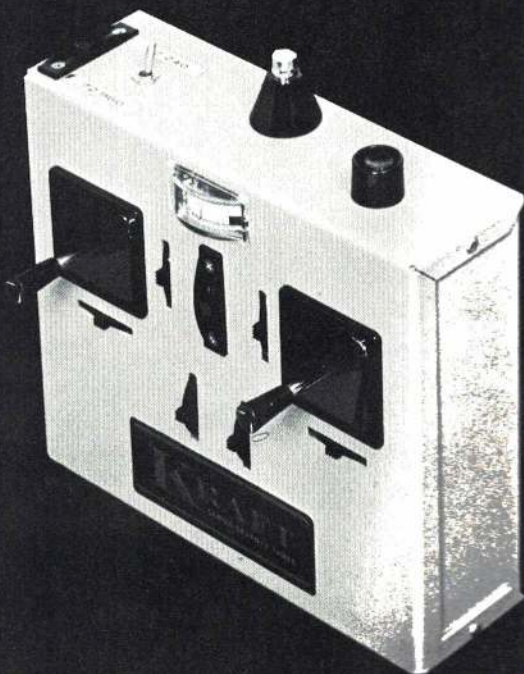

5

FOR 1973 THE BEST IS EVEN BETTER. An extra channel has been added with no increase in cost. A new low power integrated circuit decoder increases reliability and performance. Two entirely new servos have been designed to withstand even the most unreasonable abuse and, for the purist, an open gimbal stick option is available for the KP-7B.

WRITE FOR FREE CATALOG

KRAFT
SYSTEMS, INC.

450 WEST CALIFORNIA AVENUE, VISTA, CALIFORNIA 92083

World's Largest Manufacturer of Proportional R/C Equipment

● MRC-Enya 60's already impressive power levels have been improved by a new heat resistant aluminum/silicon piston with a single ring. Compression ratio has been raised to 10:1 and the crankshaft has been strengthened to handle the up to 10% increase in power it carries for 1973.

It's new and it comes complete with MRC-Enya's reputation for quality. For years MRC-Enya has been synonymous with durability and ruggedness, providing contest and sport flyers with season after season of trouble-free performance from each powerplant. This traditional long life, and easy starting, coupled with new low vibration, even more dependable idling, and increased power, make the new MRC-Enya 60 the one to beat in 1973. Take a good look at it, at your dealer's now.



Model Rectifier Corporation
2500 Woodbridge Avenue
Edison, N.J. 08817

Up to 10% more power
Higher compression ratio
New low vibration design

Take a good look at the new MRC Enya 60 BIII BBTV

YOU'LL BE
SEEING A LOT
MORE OF IT
IN '73

Specifications: Loop scavenged; two cycle; shaft rotary valve induction; 2 ball bearings; rotary type throttle valve; 10:1 compression ratio; heat resistant, low expansion, aluminum/silicon piston with one ring; .606 Cu. In. displacement; 15 oz. weight; up to 10% more power than from any Enya .60 ever produced. (All MRC-Enya parts for all Enya engines are in stock... if not available at your hobby dealer, write MRC—Parts Dept. E.)

