

● AMERICAN

aircraft modeler

THE EASY ART OF
DETHERMALIZING

RC Gliders and
Helicopters at the
'72 Nats

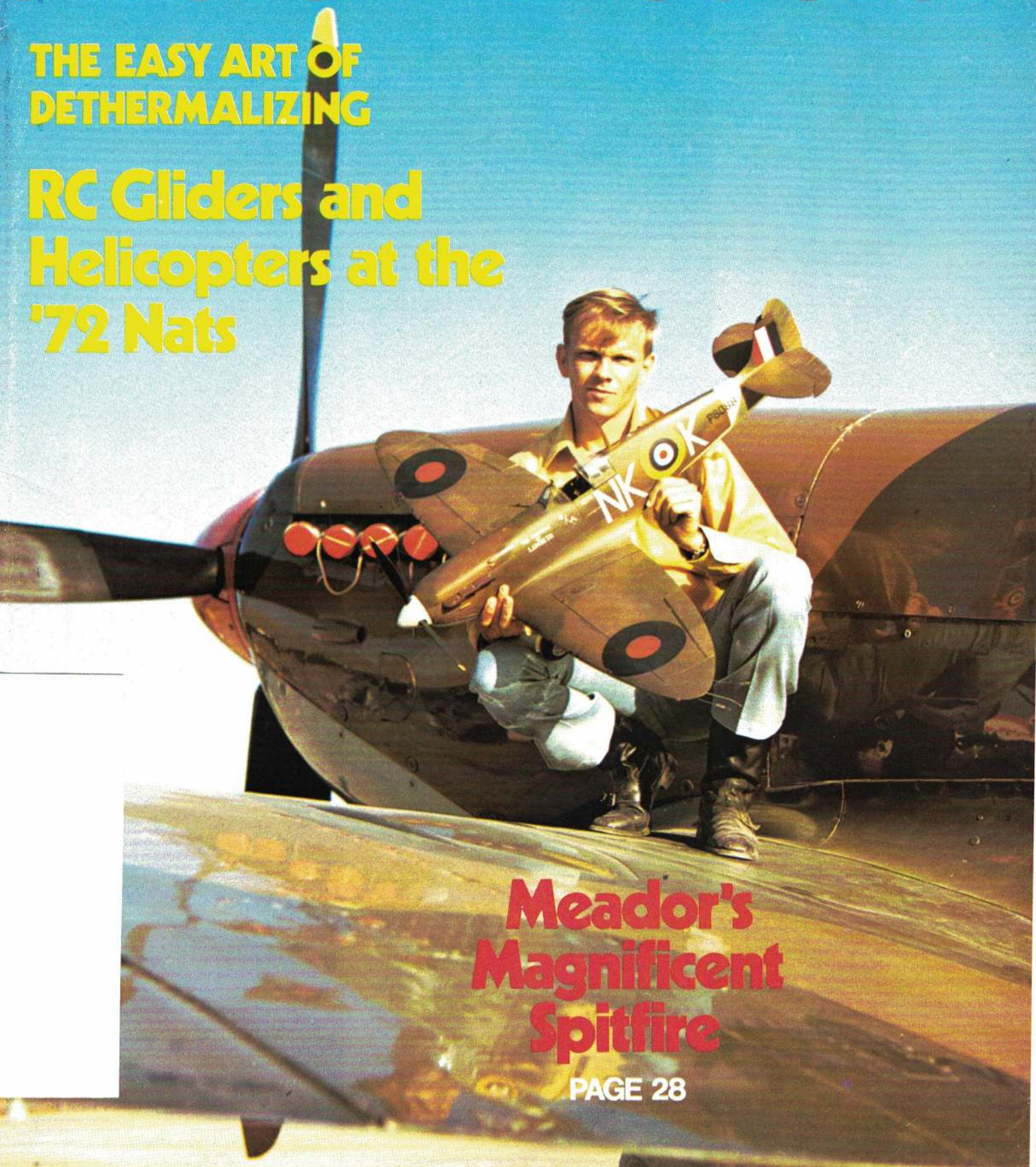

**Meador's
Magnificent
Spitfire**

PAGE 28

SCIENTIFIC

MUSEUM

Wood Ship

The kits that make Authentic Ship Modeling easy!

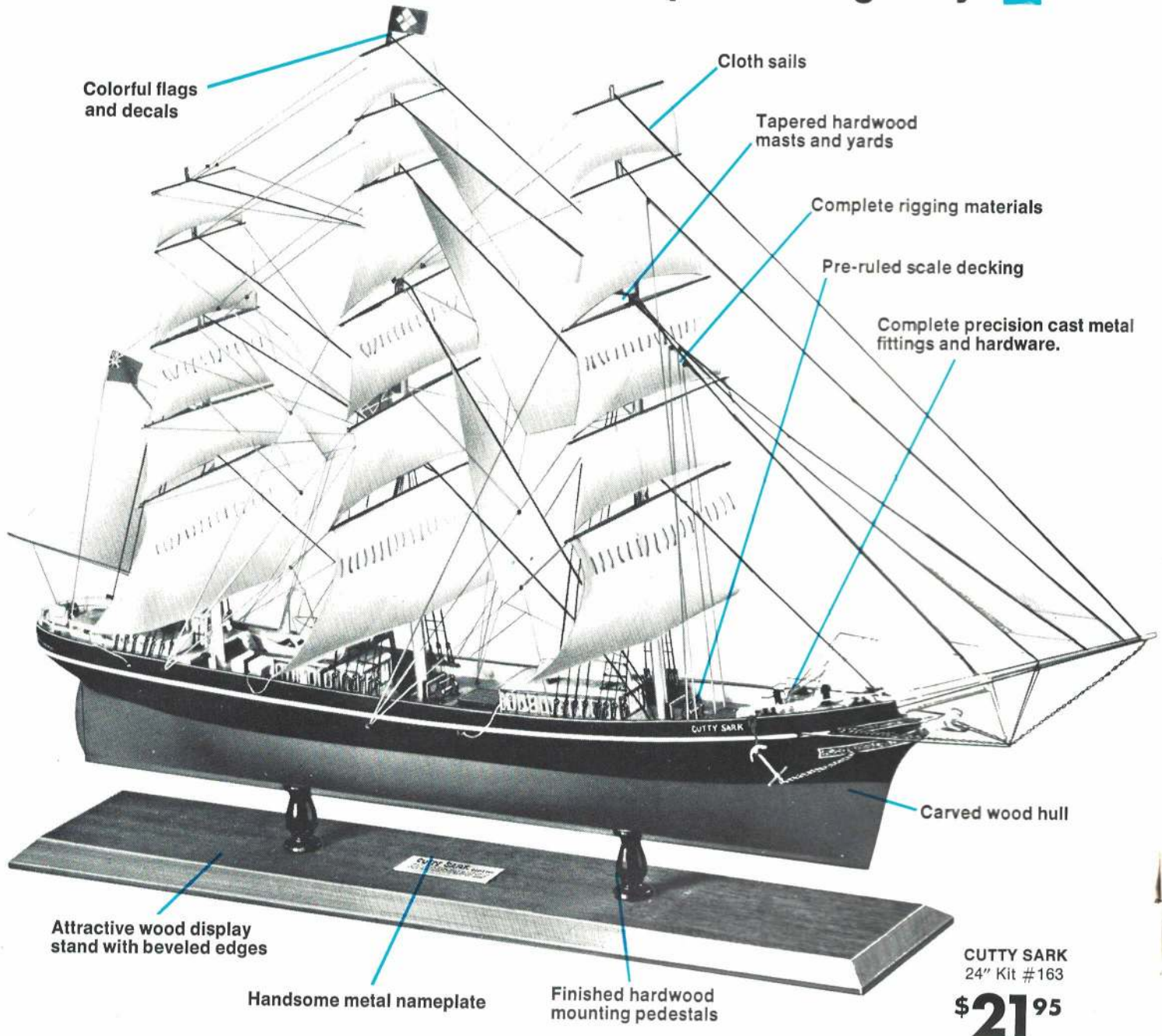

CUTTY SARK
24" Kit #163

\$21⁹⁵

Over 100 hand crafted parts including pre-carved wood hull and cast metal fittings.

- Full-size, step-by-step assembly instructions
- Highest quality wood materials used throughout
- Precision scale detailing

Now you can easily build a handsome museum quality wooden ship model like the famous clipper, "Cutty Sark", or any of the other historic sailing ships shown, even if you have never assembled a model kit before.

Each is authentic in every detail with fine craftsmanship and precision parts found in finished replicas costing hundreds of dollars. You'll be thrilled with your completed model and pleased by the salty romance it will lend to your living room, den or office.

SCIENTIFIC MODELS INC.

340E Snyder Avenue • Berkeley Heights, New Jersey 07922

SEE YOUR DEALER. If kits are not available at dealer, you may order direct from factory adding \$1.00 for postage and handling. Outside U.S.A. add \$2.00.

QUALITY

Models



A complete selection of the most famous historic ships



Kit 174 **CUTTY SARK**. The most famous Clipper. Includes realistic cloth sails. Length 15". ... **\$9.95**



Kit 177 **THE GOLDEN HIND**. Flagship of Sir Francis Drake. Authentic colorful cloth sails. L. 20" **\$21.95**

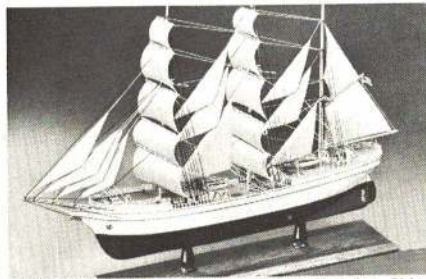

Kit 168 **EAGLE**. U.S. Coast Guard Training Ship. Cloth sails included. Length 13". ... **\$9.95**



Kit 178 **SCHOONER AMERICA**. Originated America's cup races. Cloth sails included. Length 17". **\$12.95**

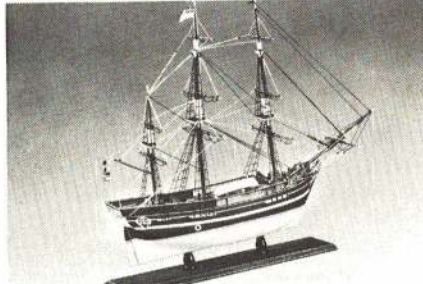

Kit 169 **H.M.S. BOUNTY**. Famous for mutiny against her commander, Captain Bligh. Length 13½" **\$9.95**



Kit 167 **FLYING CLOUD**. Clipper ship. Donald McKay's most famous Clipper ship. Length 13¾" **\$9.95**



Kit 164 **BLUENOSE**. Famous Schooner with trim lines of a racing yacht. Cloth sails included. L. 24" **\$21.95**

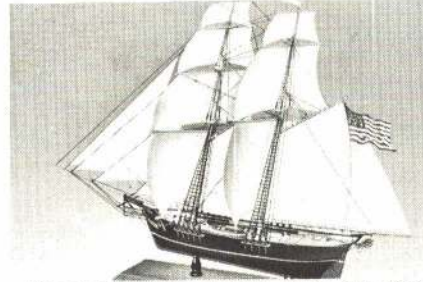

Kit 172 **BALTIMORE CLIPPER**. Pirate brig. Cloth sails included. Length 22½". ... **\$21.95**



Kit 170 **U.S.S. CONSTITUTION**. Old Ironsides. Fought 40 battles, never lost one. Length 14¼" **\$9.95**



Kit 166 **U.S.S. KEARSARGE**. Civil War Gunboat. Cloth sails included. Length 27" **\$24.95**



Kit 165 **SOVEREIGN OF THE SEAS**. A majestic Clipper Ship of 1852. Length 23¾". **\$21.95**



Kit 171 **SEA WITCH**. Clipper ship. Cloth sails included. Length 27¼". ... **\$21.95**

Seamaster Deluxe Model Kit
Length 27" Beam 8½"



SPORT FISHERMAN

free running or radio controlled

A big, deluxe kit that's loaded with all the necessary marine hardware and fittings usually sold separately. Also features die-cut and number-coded plywood and balsa parts, plastic windshield, decals, flag and full-size plans. For 6-12 volt electric motor or ½ A gas engine.

\$29⁹⁵

Kit #179

Send for our big colorful catalog only 25¢

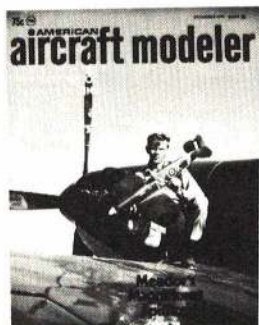

AMERICAN aircraft modeler

COVER PHOTO

One of the most beautiful aircraft at TRANSPO '72, was Bill Ross' Mk XVI Spitfire. Malvin Meador is shown with his CL model on the wing of the real plane.

VOLUME 75, NUMBER 6—DECEMBER 1972

ARTICLES

- | | | |
|--------------------------------------|-----------|-------------------------------------|
| <i>Malvin Meador</i> | 22 | VICKERS-SUPERMARINE SPITFIRE Mk IIA |
| <i>Bob Stalick & Jack Shafer</i> | 27 | BRING 'EM DOWN ALIVE |
| <i>John Thornhill</i> | 29 | DAVID |
| <i>Don Berliner</i> | 32 | HEINKEL'S PRETTIEST BIPLANE |
| <i>Glen Spickler</i> | 36 | QUICKY 500 |
| <i>Bill Potter</i> | 40 | THING |
| <i>John Burkam</i> | 42 | RC HELICOPTERS AT THE NATS |
| <i>Carl Maroney</i> | 44 | 1972 RC SOARING NATS |
| <i>Norbert Dembinsky</i> | 48 | SNOOPY |

FEATURES

- | | | |
|---------------------|-----------|---|
| <i>Jim McNerney</i> | 8 | GETTING STARTED IN RC |
| <i>Jim McNerney</i> | 16 | KRAFT SERIES 72 KP-6B WITH DUAL-CONVERSION RECEIVER |
| <i>Ed Sweeney</i> | 18 | STERLING'S FOKKER |
| <i>Don Gutridge</i> | 21 | ON THE SCENE: CAL HAWAII SUMMER FUN FLY |
| | 50 | WHERE THE ACTION IS |

ACADEMY OF MODEL AERONAUTICS

- | | |
|------------|----------------------------------|
| 97 | EXECUTIVE COUNCIL SUMMER MEETING |
| 99 | PRESIDENT'S MEMO |
| 100 | FAA ADVISORY CIRCULAR |
| 101 | FCC PROPOSAL |
| 103 | AMA NEWS EXTRA |
| 104 | CONTEST CALENDAR |

DEPARTMENTS

- | | |
|------------|--------------------------------------|
| 10 | MODELER MAIL—LETTERS TO THE EDITOR |
| 14 | NEW PRODUCTS CHECK LIST |
| 94 | INDEX TO ADVERTISERS |
| 106 | QUALITY SHOPS/CLASSIFIED ADVERTISING |

RC Helicopters—page 42

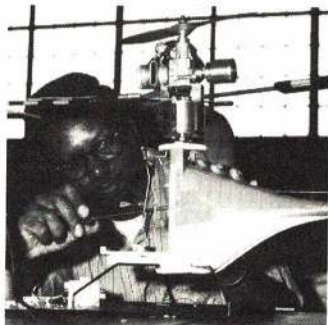

Spitfire Mk IIA—page 22



Potomac Aviation Publications, Inc.
733 15th Street, N.W.,
Washington, D.C. 20005

Edward C. Sweeney, Jr.
Editor and Publisher

Anna Maria Nunez
Managing Editor

Contributing Editors

Bob Beckman
John Blum
John Burkam
Bill Boss
Bob Hatscheck
Don Lowe
Fred Marks
Carl Maroney
Claude McCullough
Bob Meuser
Walt Mooney
Howard Rush
John Smith
Bob Stalick
Bob Stockwell
Bud Tenny

Carolyn A. Munson
Art Associate

Michele Moore
Managing Editor
RC Products Directory

William P. Kochanski
Computer Composer

Joseph R. Wright
Circulation Development

Gretchen Knowles
Subscription Manager

Mark K. Winter
Subscription Assistant

Harvey E. Cantrell
Business Manager

Abdul M. Sayeedi
Assistant Business Manager

Douglas Boynton
Advertising Manager

Benjamin Millsbaugh, M.S.
Advisor to Potomac Aviation Publications
for Aerospace Education

Stella Reed, M.S.
Advisor to Potomac Aviation Publications
for Libraries/Chairman, Board of Advisors
for Child Education

Published monthly by Potomac Aviation Publications, Inc., 733 Fifteenth Street, N.W., Washington, D.C. 20005. Edward C. Sweeney, Jr., President; Walter L. Hulstedt, Treasurer; Harvey E. Cantrell, Business Manager and Secretary.

ADVERTISING DEPARTMENT: 733 15th Street, N.W., Washington, D.C. 20005 (202) 737-4288. Western Advertising Representative: Aaron D. Viller & Associates, 5311 Venice Blvd., Los Angeles, California 90019. Tel: (213) 939-1161. Eastern & Midwestern Advertising Representative: Douglas Boynton, 733 15th Street, N.W., Washington, D.C. 20005. Tel: (202) 737-4288. SUBSCRIPTION RATES: In U.S., Possessions and Canada, 1 Year, \$7.50; 2 Years, \$14.00; 3 Years, \$20.00. Elsewhere \$9.50 for one year. Payable in advance. Single copies 75 cents. Six weeks are required for change of address. In ordering a change write to American Aircraft Modeler, 733 Fifteenth Street, N.W., Washington, D.C. 20005. Give both new and old address as printed on last label. We cannot accept responsibility for unsolicited manuscripts or artwork. Any material submitted must include return postage. When writing the editors address letters: Editorial Office, American Aircraft Modeler, 733 Fifteenth Street, N.W., Washington, D.C. 20005.

POSTMASTER: Send Form 3579 to American Aircraft Modeler, 733 Fifteenth Street, N.W., Washington, D.C. 20005.

Second class postage paid at Washington, D.C. and at additional mailing offices. ©Potomac Aviation Publications, Inc. 1972. All rights reserved. Printed in the U.S.A.

The wizard of mHz.

That's it.

A receiver that does wonders with any frequency you choose.

It selects, receives, puts power to work. The more selective your receiver, the better your control.

So we've spent years making our receiver more selective.

And it is.

It comes with our servos — the smallest, lightest servos available anywhere.

It comes with our units — the LRB, the Champion, the Super-Pro.

It comes with our low prices.

It's made for less interference, more controlled flying.

EK-logictrol.

Try it. Price it. Fly it.

And if you mean to stay in the air, take the controlled approach.

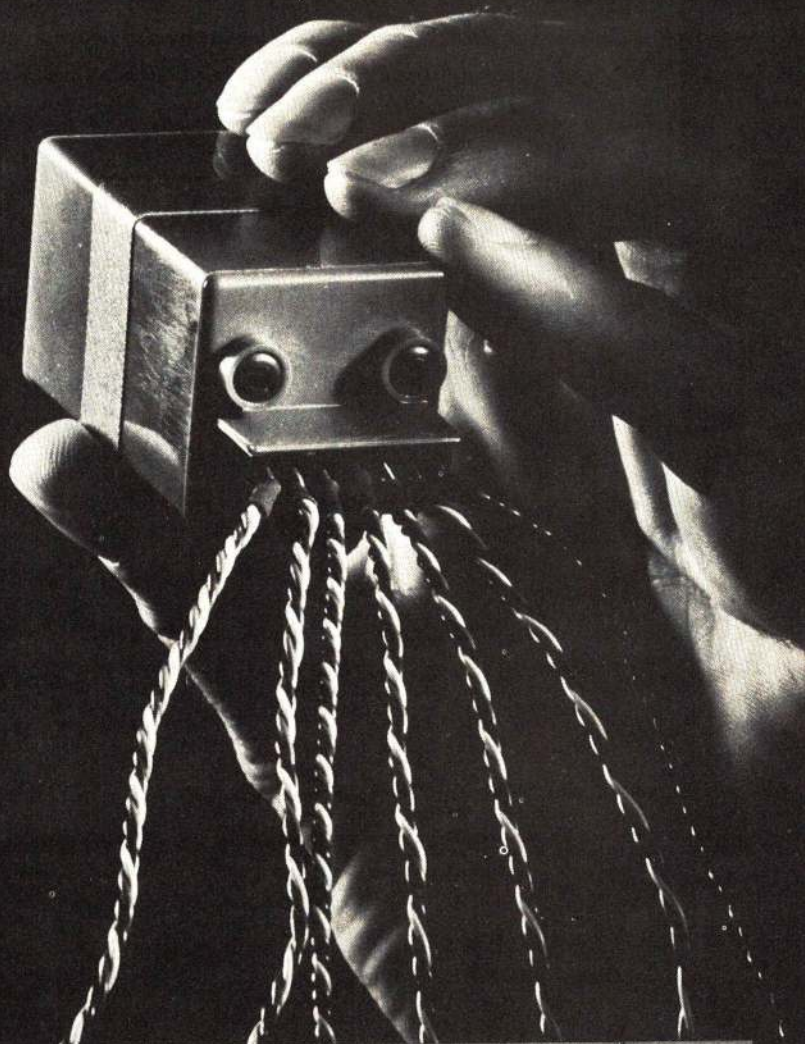

EK-logictrol
The controlled approach

For our full-line brochure, write: EK-logictrol, 3233 W. Euless Blvd., Hurst, Texas 76053

HP HOBBY PEOPLE

130 EAST 33RD STREET LOS ANGELES CALIFORNIA 90011
PRICES GOOD UNTIL DECEMBER 20

CAN'T WAIT? CALL (213) 233-4484
FOR FAST C.O.D. SERVICE

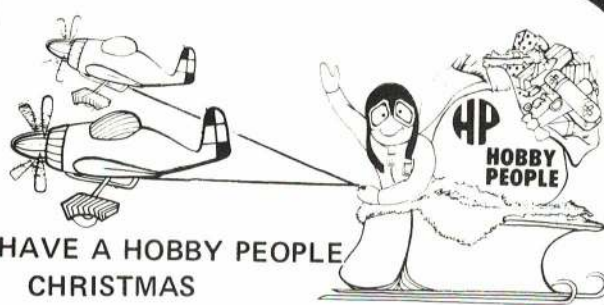

PICK-A-PAIR SUPER COMBINATION SPECIAL DISCOUNT DEAL



Dumas Smoothie



Dumas Mustang



Dumas Tom-Tom



Dumas Tomahawk



Dumas Warrior



Sterling Ringmaster



Dumas Chief



Midwest P-40 Warhawk



Midwest P-51 Mustang



Sterling F-51 Mustang



Midwest ME-109



Sterling YAK-9



Midwest P-63

FREE!
Your choice with any Combination: Pylon .015 control line OR .018 control line OR a 'HOT ROCK' U/C Handle; yours for the asking!

FREE!

HOBBY PEOPLE DOES IT AGAIN! TAKE YOUR PICK OF ANY OF THE ABOVE SIX PLANES & YOUR CHOICE OF THE FOLLOWING FIVE ENGINES: TESTORS 295TD, TESTORS 355TD, FOX 255TD, FOX 295TD, FOX 36X MIXED OR MATCHED ANY WAY YOU PLEASE. FOR A LOW, LOW SPECIAL PRICE! THIS IS ONE DEAL YOU CAN'T AFFORD TO PASS UP! DON'T FORGET THAT YOU ALSO GET FREE WITH ANY & EVERY COMBINATION YOUR CHOICE OF ITEMS IN THE BONUS BOX AT THE RIGHT.

\$19.99
VALUES UP TO \$32.00!

\$15.99
VALUES UP TO \$24.00!

NEW TESTORS/McCOY ENGINES

	LIST	SALE
#8019-195TD	\$14.95	\$ 9.99
#8029-295TD	\$15.95	\$10.75
#8035-355TD	\$16.95	\$11.43
#8040-405TD	\$17.95	\$11.99
#8119-19R C	\$22.95	\$15.48
#8129-29R C	\$23.95	\$15.99
#8135-35R C	\$24.95	\$16.83
#8140-40R C	\$26.95	\$17.47
#8000-.049 WITH TANK MOUNT & PROP	\$ 5.95	\$ 3.99

NEW!-MATTEL SIGNAL COMMAND



\$99.99 • LIST \$150.00

NEW! MATTEL SIGNAL COMMAND
Single channel rechargeable plane. Complete radio control flight. Quiet electric power...rechargeable in 5 minutes from car cigarette lighter.

COX ENGINES SALE

#130-TEE DEE .010	\$ 8.33
#160-TEE DEE .020	\$ 8.33
#170-TEE DEE .049	\$ 8.33
#210-TEE DEE .09	\$10.47
#220-MEDALLION .15	\$10.99
#230-MEDALLION .09	\$ 8.33
#240-MEDALLION .049	\$ 7.76
#350-BABY BEE .049	\$ 3.99



MINI-PEARL
Bill Chenault's sensational MINI-PEARL! Especially suited for small urban flying fields. Competition and sport free flight for latest AMA rules. Easy to build, 216 sq. in. wing. And to power this airplane we have added a Tee Dee .049 engine to power it. A \$20.00 VALUE. **\$14.88**



TESTORS R/C SKYHAWK RADIO CONTROL AIRPLANE
Ideal for beginners, Testors R/C plane is virtually indestructible, made of hi-impact styrene, easy to fly. Powered by the Testor McCoy .049 Hi-Torque engine with patented Rotomatic starter and new needle valve touch control. **\$69.99** \$100.00 VALUE



\$11.00 VALUE
SUPER SNIFFER AND COX .049
A larger version of the popular Sniffer. It is designed for .049 engines and has a 300 sq.in. wing area. A proud addition to the Midwest line of free flights. **SALE \$7.88**

MIDWEST AND TESTORS .355TD. U/C SPECIAL!



TAKE YOUR PICK OF ANY ONE OF THE MIDWEST WW2 CONTROL LINE FOR SLOW COMBAT, SPORT & STUNT. ADD A NEW TESTORS .355TD. ENGINE AND YOU WILL HAVE A GREAT U/C COMBINATION.
 K1 No. 226 MUSTANG
 K1 No. 237 KING COBRA
 K1 No. 238 MESSERSCHMIDT
 K1 No. 244 P-40 WARHAWK
 K1 No. 245 SKYRAIDER
\$18.88 \$27.00 VALUE



MATEL SUPERSTAR
\$19.00 VALUE
\$12.99
ELECTRIC PLANE WITH A BRAIN
The quiet plane with a brain!
Automatic pilot for free flights!
Choose from 4 different flight plans!
A full 26" wing span.
BATTERY NOT INCLUDED



MIDWEST-COX U/C SPECIAL
\$10.00 VALUE
TAKE YOUR PICK OF ANY ONE OF THE MIDWEST MINI-WAR-BIRDS: WARHAWK, MUSTANG, AIR COBRA, MESSERSCHMIDT. ADD A COX BABE BEE AND-- AS A SPECIAL BONUS--A GOLDBERG U/C HANDLE AND IT ALL ADDS UP TO A SUPER DEAL FROM HOBBY PEOPLE!
\$7.88

130 EAST 33RD STREET, LOS ANGELES, CALIFORNIA 90011

FIFTY-THIRD IN A SERIES

getting started in R/C

JIM McNERNEY

In our last article we discussed some of the do's and don'ts of RC installation. This month we'll talk about some of the symptoms associated with radio malfunctions, some simple trouble-shooting techniques and hints on how to stave off disaster.

The modern RC system, being made up of discrete subassemblies, has certain built-in trouble-shooting capabilities. By this we mean that, based on the particular problem that the system develops, we can quickly eliminate certain components from the list of suspects, and by a logical process of elimination eventually determine which component (i.e., receiver, servo, transmitter, harness, battery pack) is faulty. This assumes that the system has been working properly and that it has not been subject to catastrophic failure (crashed at full speed into a brick wall).

The most common, and most disconcerting type of malfunction is the "glitch," which can best be described as a momentary loss of control or spurious control operation which may, or may not, be repeated. Glitches can be caused by interference, insufficient range capability, reflections or a host of internal radio problems. If the plane is in the air, land it as quickly and gently as possible. It has been our experience that about 90% of "glitches" are ultimately traceable to an internal problem. About 10% are of the unexplained or "I was hit!" category. The most common causes for these problems are frayed or broken wires, loose electronic components, poor plug contact and intermittent battery connections.

It is important to know, if possible, which control function glitched, or if all of them did. Sometimes a glitch can be reproduced by going to high throttle on the ground (holding the model) to induce vibration. If the glitch cannot be repeated, it is still wise to make a thorough examination of all wires, plugs and components to see if an incipient failure can be detected. If you don't feel up to it yourself, have a technician give your system a thorough check. The cost is minimal compared to the possible loss of an airplane. If you can repeat the glitch, then proceed as follows.

Troubleshooting System Failures: Let us assume that the failure causes malfunction of all controls. The problem could be in the transmitter, receiver, power supplies or switch harness. The servos can generally be ruled out (but not always). The first thing to do is perform a ground range check of the

system. If the system functions normally, but at a significantly reduced range (below manufacturer's recommendation), then the problem is either reduced receiver sensitivity or reduced transmitter output (check the meter). Placing the receiver antenna too close to the servos or placing the battery pack next to the receiver can reduce radio range drastically. Be sure to follow the manufacturer's installation instructions. If the system can be made to function only by wrapping the receiver antenna around the transmitter antenna (with proper transmitter output), you may have a broken receiver crystal. A low meter indication means either a detuned transmitter or low battery output. If all the servos are "hard over" in one direction and stay there, you may have a failed cell in the airborne battery pack. This is not true in cases where the battery center tap is not used.

Now let us assume that one or more functions, but not all, are failed. First interchange "good" servos with "bad" ones. If the "good" ones continue to work and the "bad" ones don't, then the malfunction is obviously in the servos. If the "good" ones become "bad" and vice versa, then the problem is in the transmitter encoder or receiver decoder. More likely the problem is in the decoder or associated wiring and plugs. The functions have a specific sequence such as elevator, aileron, throttle, rudder. If there is a decoder malfunction in the aileron channel, given such a sequence, the throttle and rudder will probably malfunction also. It is important, therefore, to know the sequence of control functions of your radio. This kind of troubleshooting information should accompany your radio to the repair facility. It saves the technician time and can save you money. A single "nervous" servo can be caused by a poor plug connection, defective or dirty feedback potentiometer, defective motor, or defective feedback capacitor. A "sticky" (hesitates or hangs up in one spot) servo can have bad gears or a defective motor.

When checking the voltage of NiCad batteries, remember that the batteries must be under load. A cell may indicate the correct voltage with no load and drop to nearly zero voltage under operating load. In a future article we will discuss Nickel Cadmium batteries, their care, operation and testing procedures. NiCads are the least reliable component of the radio. They are the cause of the majority of radio failure crashes.



CARL GOLDBERG

ACCESSORIES PROVEN IN PERFORMANCE - PREFERRED BY THE EXPERTS! NEW! 1972 MODEL CG RETRACTS



NEW
TWIN
GEAR
DESIGN

TWIN GEAR Retracts — RG2 — \$9.95

3 Great New Features for '72 — adjustable axles, shorter nose gear steering arm and special twin-gear struts. And now CG Retracts are proving their quality everywhere — carrying 8 lbs. and up over rough grass fields with ease and reliability. When you want dependable retract performance check with the leaders — find out why most of them prefer CG Retracts!

- **LOWEST PROFILE** — Main Gears 1" high.
- **LIGHTEST** — Nose Gear, 2 Mains and 3 Struts, only 6 oz.
- **BROADEST BASED** for best stress distribution
- **TOUGH** — Rugged vibration absorbing nylon moldings. Large bearing surfaces.
- **SHORTEST TANK COMPARTMENT** — Nose Gear needs only 5½" to 6".
- **SIMPLEST** — Main Gear has only 3 molded parts.
- **EASY** — Installation or Strut Removal. Low actuating force — one retract servo can easily actuate all three units.
- **COST??** — Unbelievable! But True!

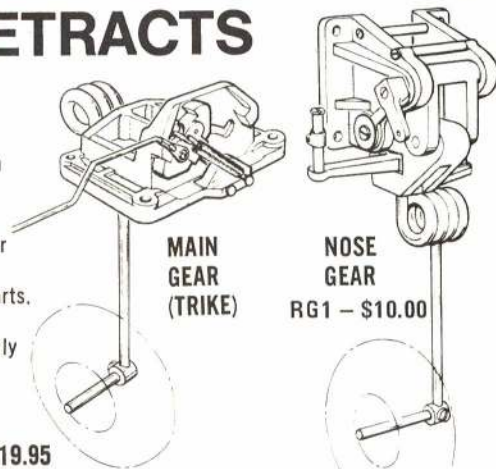

MAIN
GEAR
(TRIKE)

NOSE
GEAR
RG1 — \$10.00

TRI-GEAR Retracts — RG3 — \$19.95

UNIQUE SNAP-LINK! Patent Pending. Now for the first time—you can buy a truly safe link—the SNAP-Link!

- Tiny 45° shoulder snaps through arm, prevents accidental opening. So unique it's Patent Pending!
- One-piece design—no separate pieces that might come apart.

Snap-Link, Regular, with rod } 29¢ each
Mini-Snap-Link, with rod }
Snap-Link or Mini-Snap, less rod }
2 for 40¢



NEW—MAJOR R/C FITTINGS SETS

Here's the economical way to buy the major fittings for your multi-ship. In one set, you get all the horns, links, keepers, bellcranks, or strip aileron linkage, and hinge material—and at a saving. R/C Fittings Set No. 1 for ship with standard ailerons—\$3.50
R/C Fittings Set No. 2 for ship with strip ailerons—\$3.50

NEW! KLETT PUSHROD EXIT GUIDES



To protect your fuselage and insure smooth operation of your pushrods. Precision made of tough nylon. Easy installation. Large for 5/64" wire, small for 1/16" wire.

PEG-1 LARGE 4 per pkg. 75¢
PEG-2 SMALL 4 per pkg. 75¢

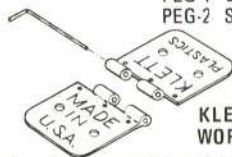

KLETT HINGES —
WORLD'S FINEST!

Designed and manufactured by Roy Klett, originator of world-famous RK hinges. An exclusive with Carl Goldberg, these hinges are made with exceptional care and attention to detail. The small RK2 hinges are so thin all you need is a knife slit. The regular size RK3 hinges are the slickest you've ever seen — try holding one leaf and waving the other! And both have removable music wire pins. Ask your dealer for the best — Klett hinges.

RK2-7 7 for \$1.10 RK2-15 15 for \$1.95
RK3-7 7 for \$1.25 RK3-15 15 for \$2.35

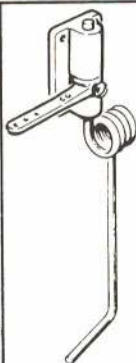

STEERABLE NOSE GEAR

Versatile — steering arm can be to either side, or slightly up or down, or mounted on bottom with extra collar in slot. Steering arm is nylon, stiff enough for good control, yet can flex under shock to protect servo. Collar is hardened steel — won't strip like brass. Screw is hardened steel, too. You can really torque it and get good grip on music wire strut without a flat.

Complete steerable nose gear with nylon bearing, 3/32" plated music wire strut, extra collar, blind nuts, screws and washers — \$2.50.



NYLON STEERING ARM
Hardened steel collar
and screw — 75¢.



NYLON BEARING

One-piece design mounts to firewall without alignment problems. Includes blind nuts, screws and washers — 75¢.



CONTROL HORNS

Our new horns have the upright part rising from the center of the base for maximum stability. Holes are right size for 1/8" wire; nut plate for simplest mounting. Long horns or short horns, with screws — 50¢ for 2.



NYLON REINFORCING TAPE

This nylon reinforcing tape is extremely tough when applied with epoxy around the center when joining wing halves. 2½" wide x 5 ft. — 50¢. ¾" wide x 5 ft. — 25¢.

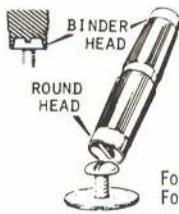

NEW KLETT SAFETY DRIVER
SOCKETS DOWN ONTO SCREW
HEAD — CAN'T SLIP OFF AND
DAMAGE YOUR WING!
Takes Round Head Screws and
Binder Head.

KLETT SAFETY DRIVER

For ¼" Nylon Screws } 98¢ each.
For #10 Nylon Screws }

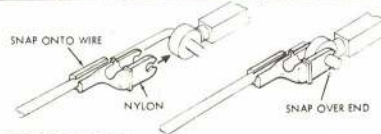

SNAP'R KEEPER

Quickest, handiest way to secure pushrod wire end to servos, horns, etc. Works on wire ¼ to 3/4" diameter — 50¢ for 4.

REPLACEMENT FOAM WINGS, ETC.

To go with your own design fuselage. Proven efficient Ranger 42 foam wing gets you in the air quickly — \$3.95. Stab and vertical fin, set \$1.95. Assembled Ranger 42 fuselage, plus bearings, nosegear, etc., \$8.95.

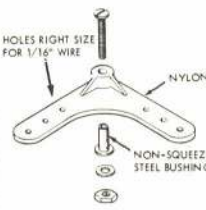

AILERON BELLCRANK

Bellcrank has steel bushing of proper size, so crank can be screwed firmly in place without binding. No electrical noise—all metal parts are screwed tightly together — 50¢ for 2.

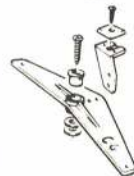

½A BELLCRANK and HORN

Made of nylon, this new set provides smooth ½A control line operation. Easy on dacron lines, too — 25¢.



SHEET METAL SCREWS

Like wood screws, but better. Sharp, clean, full-depth threads, hard and strong. Excellent for mounting servos, etc. Includes washers — #2 x 3/8 — 30¢ for 10; #4 x 3/8 — 30¢ for 8.

P.S. For best service, see your dealer for items you want. If not available, write direct; add 50¢ per item (\$1 outside U.S.). Minimum order \$1.

MANUFACTURERS—All our accessories are available at excellent O.E.M. bulk prices.

Carl Goldberg Models Inc.
2545 W. Cermak Rd., Chicago, Ill. 60608
I am sending 25¢ for 8 pg. Illustrated Catalog with, "Recommendations in Starting in R/C," Basic Explanation of R/C Equipment and Radio Control Definitions.

Name _____
Address _____
City _____
State _____ Zip _____

Available in
Canada



Modeler Mail

RC novice stationed in Germany

Being stationed here in Germany where RC flying is quite popular, I had the opportunity to join the RC Club in Aschaffenburg.

A few years ago I was an avid CL flyer so I figured the transition would be fairly simple; however, that couldn't be further from the truth. It has been an uphill grind all the way. Sometimes my Army duties keep me away from it for weeks at a time or a crash will sideline me for a while as is the situation at present.

Any and all ability I gain during my short flying periods is lost because I haven't been able to learn enough to retain much of it.

The Germans are great and help me as much as they can, however the language barrier is quite a handicap. I return to the States in February and I plan to join the nearest RC club to my duty station, but I would like to learn as much as possible before leaving Germany.

I am using Graupner Varioprop radio gear and have concentrated on slow, rudder, elevator and motor only trainers. I am told that using ailerons is easier, and some say rudder-only is the best to learn on. Right now I really don't know how I should go.

I am constructing a motor glider in hopes that it will hold together long enough for me to learn the basics. Any



NEW! Aero Precision FOCKE-WULF TA-152 kit \$39.95



58" wing span, 450 sq. in. wing area for .30-.45 engines and 4 channel radio equipment. Very simple construction kit for this beautiful WWII fighter. Nice hardware, canopy and well detailed plans using isometric drawings for ease of construction.

NEW! Airtronics QUESTOR R/C Sailplane \$26.95

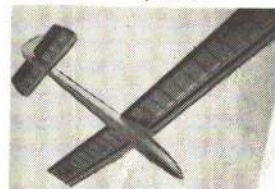

62" wing span, 409 sq. in. wing span 2 channel thermal or slope soaring glider. Can be lofted with an .049 on a power pod or by Hi-start. Conventional all balsa construction EXCEPT that one look at the way Airtronics machined the wood parts of this kit and you'll find it hard to believe that it'll take you as long to build it as the "6 to 8 hours" mentioned on the kit. Complete hardware, too.

NEW! Sullivan 12 VOLT ELECTRIC FUEL PUMP \$11.95



12 volts-operates directly off of your starting battery! This pump has everything: One year guarantee, a mounting bracket, filters, fuel lines, switch, insulated battery clips, one ounce per second capacity.

NEW! Shelor FOAM WING CUTTER \$36.95

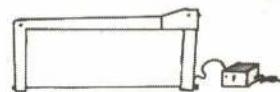

With this well-thought-out cutter you can quickly cut foam wing cores for a material cost of about 67¢ per set. This is a transformer type cutter which eliminates any shock hazard, and has the best instructions I've ever seen covering the method of properly cutting foam wing cores.

NEW! Robart HORNY HINGE POINTS 4 for 79¢

A mildly nauseating name for an otherwise clever gadget—a Hinge Point with an integral horn.



THE BIGGEST YEAR-END CLEARANCE SALE
WE'VE EVER HAD!

HOBBY LOBBY 5

DIGITAL PROPORTIONAL



REG. \$209⁰⁰

Extra Special \$189⁰⁰

We will introduce the 1973 Hobby Lobby radio in January of '73. The '73 Hobby Lobby Digital Proportional will have features that will give a measure of performance and reliability surpassing some of the most expensive radios made.

But meanwhile we must completely sell out our supply of Hobby Lobby 5's—a radio that regardless of price is considered one of the finest systems ever made. So . . .

HERE'S YOUR CHANCE TO GET ONE OF THE BEST RADIOS EVER MADE, AT A PRICE THAT CAN NEVER BE OFFERED AGAIN!!!

NEW OFFER!!!
Blue Max Mark II
6 CHANNEL
SEMI KIT



with 4
FULLY ASSEMBLED
SERVOS

\$173.00

Previously, the Blue Max SEMI kit digital proportional has come with one assembled servo (which is used as a reference servo) and three semi-kit servos. Now, **ALL 4 SERVOS ARE FULLY ASSEMBLED.** This feature not only save you the time required to assemble the servos, but also guarantees you of perfect completion of the **ONLY** ticklish soldering job involved in the SEMI kit. The rest of the assembly is very easy.

Outfit includes semi kits for transmitter, receiver-decoder, charger, and 4 assembled servos. Complete n-cads, factory warranty on all factory assembled P/C boards. Your choice of 27 or 72-75 mhz. frequencies.

NEW HOBBY LOBBY 2 **\$79⁹⁵**
DIGITAL PROPORTIONAL

HOBBY LOBBY 2 is a complete ready-to-fly two channel digital proportional system with excellent range for demanding uses such as high altitude R/C gliders.

HOBBY LOBBY 2 is designed and constructed to give the ruggedness and reliability that make it a great beginner's outfit for rudder & elevator or rudder & throttle control in planes like the Falcon 56, Tri-Squire, Headmaster, and Lanier Aztec.

HOBBY LOBBY 2 is complete as pictured and includes transmitter with deluxe 2 axis control stick & trim controls, receiver, 2 World Engines, TS-5 Servos, battery box and switch harness, 27 mhz. band. Outfit uses inexpensive dry cells (not included). Add \$6.50 if you want 72-75 mhz. band.

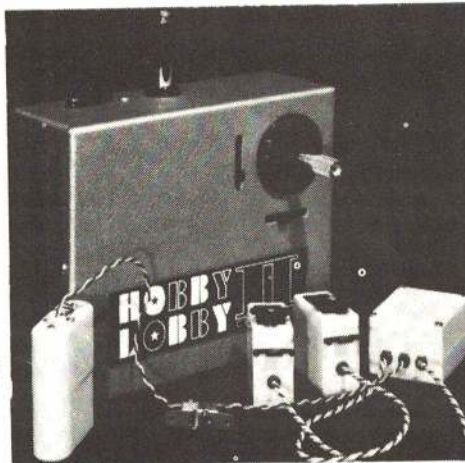

SENIOR TELEMMASTER
\$49.95

With a 95" wing span this 4 channel behemoth is the largest RC model kit we know of. This is a **REAL** easy-to-build kit of the finest, lightest balsa wood you'll ever see.

When you get your **SENIOR TELEMMASTER** all finished you'll have a **GREAT BIG** monster of an airplane that flies like a tranquilized albatross. It's supposed to use a .40-.60 size engine, but I believe you could keep it in the air with a .19.

NEW! Rocket City RETRACT SERVO ARM

for KPS-10 **98¢**
for World Engines servo **98¢**

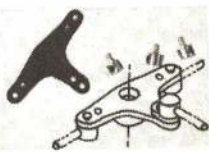

For 3 pushrod take-off on rotary servo. Choice of 2 different throws, has special rotating push rod holders.

HOBBY LOBBY ILLUSTRATED CATALOG \$2.00



Hobby Lobby NYLON COVERING MATERIAL
\$2.95
39½"x65"

NEW! Hobby Lobby's BRAND X WHEELS

- 2" pair \$1.00
- 2¼" pair \$1.15
- 2½" pair \$1.30
- 2¾" pair \$1.45
- 3" pair \$1.55



TRY US OUT: Major M. C. did:

"We had a minor problem with invoice 14304, but you guys responded rapidly, and the problem is solved . . . I'm not sure how it happened, but I just got my **SECOND** replacement order. You guys are really set up to give the customer the benefit of the doubt. It's almost overkill. As a friend of mine says, though, "Never undersell overkill."
Major M. C. APO New York



HOBBY LOBBY INTERNATIONAL

Route 3, Franklin Pike Circle, Brentwood, Tennessee 37027 - 615/834-2323
DROP YOUR ORDER IN THE MAIL BOX, THEN JUMP BACK BECAUSE WE SHIP FAST!
We pay postage on all orders accompanied by check or money order. Satisfaction guaranteed or money refunded. Phone 615/834-2323 Store Hours: 9 a.m. - 5 p.m. except Sundays.

Hobby Shack

ENGINEERED FOR THE TOP PERFORMANCE BRACKET

Taipan

cessna
skyhawk \$89⁹⁹



15R/C
Retail Price \$24.95
OUR PRICE
\$19⁹⁶



SPECIFICATIONS: Fuselage (fiberglass), engine cowling (fiber glass), wing (styrofoam/balsa), main gear bent to shape, wing strips (fiberglass), wing strut (hardwood) elevator unit complete (balsa) rudder unit complete (balsa), Span: 63", Engine: .40, Weight: 5 pounds, 13 ounces. Wheel pants (Opt.) \$8.99/set.

We are importing from Germany the spectacular Leima Model CESSNA SKYHAWK. This is the latest 1972 version built in accordance with original Cessna blueprints. The high impact resisting polystyrene glass fuselage shows many details which will give you a model true to the original.

- 19R/C
SCHNEURLE Retail Price \$29.95 OUR PRICE **\$23⁸⁸**
- 19 STD.
SCHNEURLE Retail Price \$18.95 OUR PRICE **\$14⁸⁸**
- 15 Standard Retail Price \$15.95 OUR PRICE **\$12⁷⁶**
- 15 Diesel Retail Price \$28.95 OUR PRICE **\$22⁶⁷**
- 09 Diesel Retail Price \$16.95 OUR PRICE **\$13⁶⁷**



EVERYTHING -U- NEED \$99.99⁰⁰

MIDWEST CESSNA CARDINAL, CIRRUS DIGITAL 2CH., Plus COMPLETE HARDWARE, SUPPLIES, ENGINE AND GAS Plus BATTERY TOO!

TOTAL PAK is our way of helping you get off the ground in R/C at the lowest price. The cardinal is an ideal starter plane because of its ease to build and great stability for beginner flying. The Medallion .09 is perfect for power and the CIRRUS may be used for elevator and rudder control. Everything-U-Need; Cessna Cardinal, Cirrus 2 CH. RADIO, 1 pr. 2" Dubro wheels, 1, 1 1/2" Dubro nose wheel, Cox Medallion .09, 1 SS-3 Gas tank, 1 spinner, 1 pkg. fuel line, 1 pk. Dubro collars, 1, 1/4lb. box of rubber bands, 1, Hobbyposy glue, 1, perfect mounting bolts, 1 propeller, starting battery, fuel, glow plug clip and filler line for fueling.

Midwest SUPER CHIPMUNK & TAIPAN 15 R/C -COMBO-



Here's a beautiful stunt trainer with a 46" span. The Taipan 15R/C will make flying easy!!!! \$49.90 VALUE

SALE \$36⁹⁹

RCM Basic Trainer & Taipan 15 R/C Combo!

Retail \$52.90



50."Wing Span 2 to 4 Channel Flying Fun!!!!

\$36⁸⁸



RADIO SALE

6 CHANNEL BLUE MAX MARK II IC ASSEMBLED.

This month we offer a special sale price on the 6 CHANNEL BLUE MAX MK II IC complete with 4 RS-5 servos, Ni-Cads, charger, and switch harness. This is a particularly good buy so order early as they will most likely go fast. You will note that our special discount price is not much more than the price on the 4 channel Blue Max system.

DISCOUNT PRICE **\$225.00**

6 CHANNEL MARK II SEMI-KIT

Without electronic experience you can save X-tra \$ \$. . . just finish the mechanical assembly and wiring hook-up. Retail \$239.98

DISCOUNT PRICE **\$179.00**

CIRRUS 2CH. RADIO AND CANYON SCHWEIZER 1-26 GLIDER -COMBO-



\$95.88 for combo on 72 mHz.

All foam glider 41" in length and a 6 foot 6 inch span. About 2 hours building time.

SALE PRICE **\$89⁹⁹**

Or choose the Schweizer w/ the E.K. LRB 2 servo Brick! **\$116.87**

FASTEST, EASIEST C.O.D. QUICKEST. (714) 522-4921

advice and help your readers might be able to offer would really be a bonus to me.

SSG Donald Field, D. Co. 9th Engineer Bn.
APO New York 09162

Mother and son carry on

A few years ago Jim Scott had a shoe sales and repair shop on the ground floor of his small house in a little town in Scotland. Since boyhood, Jim had dreamed of making kits and plans for true scale model airplanes that would be superior in quality and in accuracy of detail. He dreamed of being able to market them at a reasonable price. With great determination and little else he and his wife began the business. They wanted these ships to be large enough for the average builder to easily work in scale details, so most builders would be able to make use of the new 60 engines. Jim used the system that has been famous in Scottish wool weaving—he encouraged individual craftsmen to hand cut parts for the kits in their own homes. This insured that the business would not depend on a single person. Last year they sponsored the second RC Scale Air Meet in Scotland, with pilots from as far off as London flying ships made famous during the war years. Two of the favorites were the P-47 Thunderbolt and the Spitfire.

Jim and Evelyn saw many lean years in developing their aircraft and last year, for the first time, saw indications of success as the business increased to a point where they could make ends meet and have a little left for needed equipment. Evelyn helped with the books and son David, aged 20, joined the business as assembler and shipper. Jim could now begin to correspond and plan additional business.

On August 24, 1972 Jim died at the age of 41 after a brief illness. This leaves Evelyn and David with the responsibility of supporting the three younger brothers. With typical Scottish determination, they feel obligated to carry on Jim's business and the name "Complete-a-Pac." I don't know how many of us there are flying RC that have never built a true scale airplane, but would like to. I, for one, will make my next project a Complete-a-Pac Tiger Moth in memory of Jim and so that I can send a photo to his son David.

Ben Brown
China Lake, Calif.

Poet's Corner

The Bird

My ears are filled with the snarl of sound,
Brow furrowed with care,
As I watch my model on the ground,
Idling prop turns round and round,
As a zephyr reaching for the air.

Transmitter nestled on my arm,
Fingers resting on control,
Hoping the plane will do no harm,
Come to no grief, cause no alarm,
When I release her sky bound soul.

Throttle opened to full bore,
My birds wings tremble as she slides,
Down the runway hear it roar,
Till earth feels her touch no more,
As she challenges the winds own tides.

I built that speck up in the blue,
Each former, strut and wing rib made,
Installed with nuts and bolts and glue,

6475 KNOTT AVE. BUENA PARK, CALIFORNIA 90620

Electronic gear to fly her true,
From plan to plane long evenings fade.

So there she dives, she spins and turns,
And immelmans, once, twice, a third,
Gently glide, as she returns,
My soul, the pilot of my bird.

R. M. Clark
Pleasantville, N.J.

Attention Loughead fans

Readers contemplating building a model of the Loughead S-1 may wish to examine the fine article on the machine by Cedric E. Galloway, which appeared in Volume 15, Number 4, Winter 1970 edition of the *American Aviation Historical Society Journal*. Featured in this article are excellent photos, a three-view drawing, specifications and an informative text. We were pleased to see Mr. Galloway's beautiful static scale model of the S-1 at last year's North American Rockwell Annual Scale Model Contest.

W.C. Hannan, Escondido, Calif.

Patriotic Reader

As a constant reader of AAM every month, I must tell you of something that gets me very upset.

In reading your AMA section, I find that when referring to International Competition, AMA takes it upon itself to place it first before the United States. For example, the AMA would state "The modelers were representing the AMA and the U.S." Shouldn't it be stated: "...representing the U.S. and AMA?"

Paul Schumacher
Jersey City, N.J.

Hobby Shack

\$219⁰⁰



WHY BUY A 4 OR 5 CHANNEL WHEN OUR 6 CHANNEL IS \$219?

Complete 6 Channel system with all the great features of a \$450. radio, but because it's our Cirrus you only pay \$219. You get a 6 channel 2 stick transmitter, 6 ch. receiver, 4 RS-5 mini servos, all Ni-Cads (trans & Airbourne), charger, switch harness, and buddy box. Available on 27 mhz or 72 mhz - specify when ordering your new radio from Hobby Shack. Full 90 day warranty - serviced by World Engines.

2 CH.
\$69.95



CIRRUS 2 CH. \$69.95
CIRRUS 2 CH. \$69.95
CIRRUS 2 CH. \$69.95

If you have been wanting to get into Radio Control or needed an extra 2ch. system, now is the time. We are offering a full digital 2 channel rig complete with 2 separate servos, IC (integrated circuitry) two wire battery pack (dry) and a two stick transmitter with trim. Unheard of? How can we do it? Simple—the radio is factory direct from us to you. There are no distributors or other middlemen and these savings are passed on to you. For 72mHz. add \$10.00

COX PINTO



Cox 049 powered! Authentic 1/12 scale funny car. Automatically ... drops a drag chute!
Comes complete w/ **\$12.99** guide line & pins.

COX SOPWITH CAMEL COX .049 POWERED!



13" wing span, and all the details of the authentic WWI plane **\$7.99**

WE'RE OPEN 7 DAYS A WEEK AND EVENINGS TOO!
SHOWROOM STORE HOURS
MON. thru FRI. 9am -9pm
SATURDAYS 9am -5pm
SUNDAYS 10am -3pm



TAIPAN 15std. & Midwest U/C Prof. SCALE WWII PROFILES FOR GREAT FLYING FUN IN THIS SPECIAL COMBO
Choose: ME-109 / P-51 Mustang / Warhawk / or the King Cobra. All have 33" spans, 244 sq." areas and .15 engine displacements.

both retail \$23.90 **\$16.73**

Hobby Shack
DISCOUNT MODEL CATALOG
Hobby Shack
DISCOUNT HOBBY CATALOG

FULLY ILLUSTRATED PAGES OF R/C PLANES, R/Control SETS, PARTS, ACCESSORIES AND SUPPLIES, PLUS MODEL BOATING SECTIONS & GAS POWERED ENGINES

I enclose \$1.00 for your fully illustrated modelers catalog. Please rush it to me today!

MAIL THIS COUPON TODAY; TO:
HOBBY SHACK
6475 KNOTT AVENUE
BUENA PARK, CALIFORNIA 90620

NAME _____
ADDRESS _____
CITY _____
STATE _____ ZIP _____

POSTAGE & HANDLING

Orders to \$ 5.00 add \$.90	\$20.01 to \$30.00 add \$2.50
\$ 5.01 to \$ 8.00 add \$1.00	\$30.01 to \$50.00 add \$2.75
\$ 8.01 to \$15.00 add \$1.20	Any Order
\$15.01 to \$20.00 add \$1.60	Over \$50.00 add \$3.00

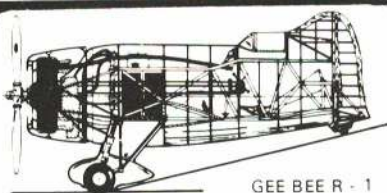

GEE BEE R - 1

the national
AIR RACERS
in 3-VIEWS 1929-1949

3-Views galore - all of the great classic Thompson, Bendix, Greve and Goodyear air racers are shown in magnificently detailed drawings - AND THERE IS MORE - Voluminous notes give the full story of each racer - pilots - race results - construction and performance data - color schemes and markings - everything the race enthusiast, modeler, and historian could desire. The Golden Era is recreated on large, crisply printed 8 1/2 x 11 pages covering over 90 aircraft.

American Aircraft Modeler ... provides excellent 3-views ... truly outstanding research.

R/C Modeler - "This book is full of drawings and construction details ... we recommend this book as invaluable to anyone interested in scale details of the famous air racers."

Airpower - "The drawings are accurate, profuse and very thorough."
Cleveland Press - Aviation Editor - "a treasure of plans and information."

\$3.95
POSTAGE INCLUDED

The Diane Publishing Company
P.O. Box 2726 Dept. 1
Rochester, New York 14626
New York State residents please include sales tax.



Name _____
Street _____
City _____
State _____ Zip _____

New Products Check List

FRANK PIERCE

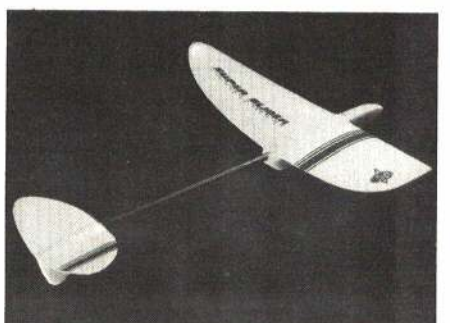
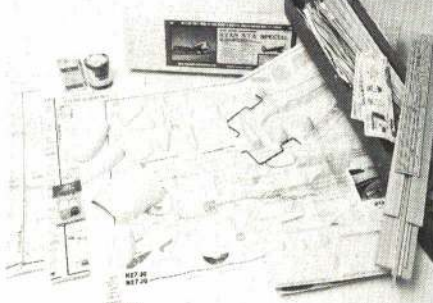
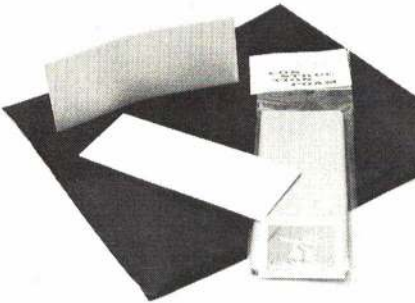
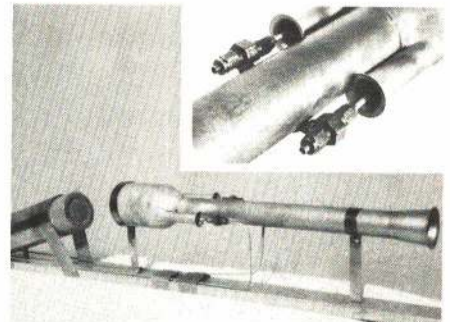
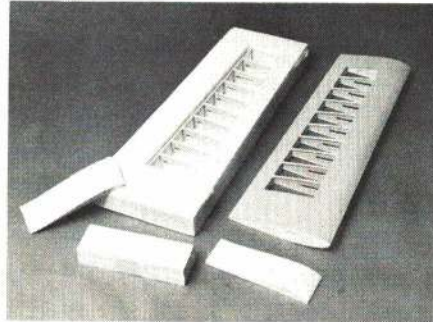
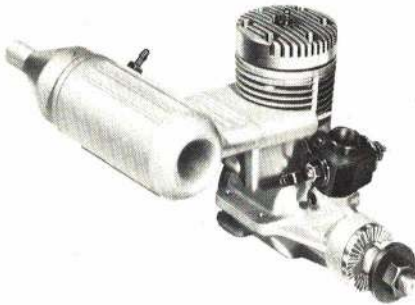

Veco/61 RC. Another in the Series 72 line, engine has Flow-Thru muffler built in as standard equipment. Improved design features include beefed-up housing and new head, piston cylinder, ring, rod, and improved port timing. \$74.95. K&B Mfg., 12152 Woodruff Ave., Downey, Calif. 90241

Mason Renshaw/Extra-light stock foam. Remember the ultra-light foam glider kits from Mason Renshaw which we covered last year? Now, the same three-lb. per cu. ft. expanded polystyrene foam is available in bulk form for your own designs. In packs of varying sizes from .030" through 3", \$1. Mason Renshaw, Box 445, Carpinteria, Calif. 93013

HobbyPoxy/Glues and finishes. Shown is an array of HobbyPoxy products including well-known 45-minute/3-hr. formula No. 2 epoxy glue. Also: "Stuff," putty-like material for dent repair and fillets, Polyester resin for priming or natural wood gloss, enamels in two 1/4-pint cans with pigment (Part A) and hardener (Part B). Write for four-page brochure for complete line and prices. Pettit Paints, 507 Main St., Belleville, N.J. 07109

Foam Flite/Balsa and foam wings. Combines the lightness and looks of a rib wing with the strength and accuracy of foam. All covering including rib caps are of top-quality Sig balsa. Available in three levels of assembly: covered, uncovered, and foam-rib kit. For Nobler, Chipmunk, Akrobat, Shark 45, Skylark. Also available: custom-built wings to your specs. Write for prices and ordering information. Mankato Models, 628 W. 6th St., Mankato, Minn. 56001

Sig/Ryan STA. What a kit! Scale detail hardly ever seen even in great scale kits. Starting with a series of detail pictures of the prototype, even the instruction book is a pleasure to read. All balsa built-up construction, 43 formed ABS plastic parts, 72" span decals, photo-sheets of the actual instrument panel reduced to scale size, instrument rings, scale spinner. Also available, set of color photo prints of full-scale plane. Not a project for the "Start on Monday Evening and Fly the Next Weekend" type but a kit where you can make your craftsmanship known. For 60 power. \$54.95. Sig Mfg. Co. Inc., 401 S. Front St., Montezuma, Iowa 50171

Peck Polymers/More peanut scale. Another in a series, kit is impressive because of its quality in spite of its small size. Photographic step-by-step instructions, competition-grade balsa and rubber. *Pietenpol* was one of the most attractive home-builts of the '30s and is equally attractive here. \$2.33 postpaid. Peck Polymers, Box 2498, La Mesa, Calif. 92041

Thermo-Jet Standard/Propane jet engine. New approach to jet power, pulse jet operates on propane gas, uses no moving parts or separate ignition system. Fuel is supplied under own pressure to twin inlets, throttle is adjustable over 50 to 100% power range. Built-in design safety prevents dangerous pressure build-up above 20 psi. Available in two sizes, J3-200 and J5-300. 200 is 21" long, has three lb. thrust; 300 is 35" long, has ten lb. thrust. Prices, \$56.95 and \$98. Also available: Spark-plug igniter for remote starting applications, \$7.50. Detailed instructions. For advanced hobbyists only. Thermo-Jet Standard, Box 1528, Kerrville, Tex. 78028

Hobby World/Bell P-39 or -63. Kit forms the basis for P-39 Aircobra or P-63 Kingcobra. 1/4-midget kit contains fiberglass fuselage, foam core wings, needs only balsa, standard hardware and decals. With landing gear blocks, firewall already installed. \$34.95. From Bob Reuther's Hobby World, 6602 Highway 100, Nashville, Tenn. 37205

Progressive Sales/Super Glider. New line of hand-launched gliders comes ready to fly in merchandizer cartons. Total weight of 25 grams with 14" polystyrene foam wing, wood boom, nylon nose section. Outstanding flight characteristics, can catch thermal for fantastic "final" flight. In red, blue, gold. \$1.29. Progressive Sales, Box 474, Charter Oak, Calif. 91724

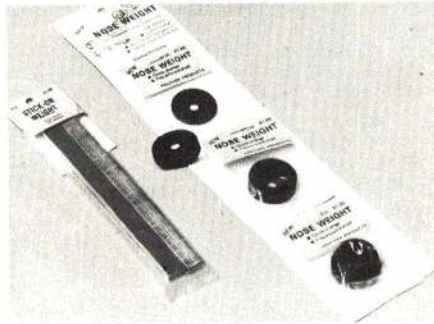
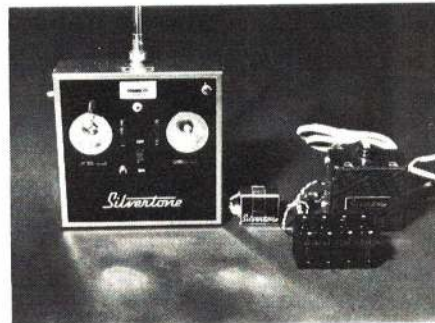
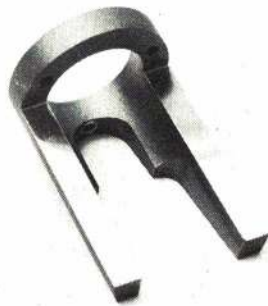

Cox/Saturn V and launcher. A perfect realistic display model in 1/125 scale or operating single-stage flying model capable of spectacular flights. Twin parachute recovery system floats nose and body to ground separately. Flights up to 650-ft. altitudes obtainable with D-13-4 engines. Beautiful packaging, 33 1/2" high. Also, launch system sold separately, features steel exhaust deflector, brass tubing for launch rod, control switch, base with provisions for eight D-cell batteries. Range of engines available for mild to blazing performance. Safety is designed into kit. Write for complete catalog to L.M. Cox Mfg. Co., Inc., 1505 E. Warner Ave., Santa Ana, Calif. 92705

EK-logictrol/New catalog. Specifications for LRB, Champion, Super Pro systems, full-size drawings of Mini-Mite, Super Mini, Super Pro, and LRB servos, receivers, and Unipacks so you can plan your layout while awaiting delivery of a new system. When you're finished, give catalog to art or photographic buff and watch them turn on over most beautiful layout this side of an art book. EK-logictrol, 3233 W. Eutess Blvd., Hurst, Tex. 76053

Vortex/RC racing yacht. 50" model of 27' Soling-M is highly maneuverable and can be sailed where draft doesn't permit larger boats. Kit features factory-installed keel mounts, cast-iron keel, deck detail, many other features to make assembly easier. 12" beam 798 sq. in. sail area, operates on 2- or 3-channel control. Basic kit, \$125; assembled with Vortex sail control system, \$350; with radio \$510. Vortex Model Engineering, 210 E. Ortega St., Santa Barbara, Calif. 93101

CB Enterprises/Motor Mounts. Precision aluminum in eight sizes from 2 to 4". CB Enterprises, 21590 Cloud Way, Hayward, Calif. 94545

Prather Products/Precision ballast. For accurate initial trimming of models, spinner weights come in sizes ranging from 1/2 to 2 oz. Easy to install and change, weights fit behind prop nuts, will not interfere with spinner. Stick-on weights, come in 3-oz. strips marked off in 1/4-oz. increments. Spinner weights, \$1.69 to \$1.99; Stick-ons, \$1.98 for two 3-oz. bars. Prather Products, 1660 Ravenna Ave., Wilmington, Calif. 90744

RC Helicopters/Bell Jet Ranger. Main rotor diameter 60", fuselage, 58", flight duration about 25 min. More on this model in future columns. R/C Helicopters, Inc., 4550 White Plains Rd., Bronx, N. Y. 10470

Silvertone/Mk VII System. From Australia, Mk VII has most complete buddy-box operation available for safe flying by novices. Expandable 2- to 6-channel operation, 22 frequencies with optional plug-in crystals, 12-oz. airborne system weight, choice of PS-3 or PS-6 type servos, full-wave battery charger. For more info, write Strato Model Products, Rt. 6, Olyphant, Pa. 18447

DA Enterprises/Charg-R-Start. This new starting battery comes complete with a 2 volt, 6 amp wet cell battery, an ammeter for checking glow plug condition, an internal charging system and an indicator light. A power cord is provided and the battery can be recharged simply by plugging it into an 110 volt AC outlet. \$29.95 from DA Enterprises, Box 335, Haubstadt, Ind. 47639



**KRAFT SERIES 72 KP-6B
WITH DUAL-CONVERSION
RECEIVER**

JIM McNERNEY

The best way to describe the Series Seventy-two Kraft is to point out the differences from the earlier Kraft radios, and this year there are lots. With only minor circuitry changes, the transmitter and receiver electronics have remained virtually the same from the introduction of the Gold Medal series in 1968 through the Series Seventy-one. One notable change in the Series Seventy-one was the addition of a high equivalent capacitance filter on the decoder board. This filter was added when it was planned to introduce an IC servo amplifier in 1971. The original IC amplifier was abandoned; an IC bridge amplifier was developed and put in the Series Seventy-two. Thus the Series Seventy-two receiver is identical to the Series Seventy-one.

For 1972, Kraft has introduced an optional receiver at extra cost which provides dual conversion of the transmitted signal. This means that the RF signal is first mixed with a local oscillator signal 10.7 MHz different from the radio frequency. The difference signal, or first intermediate frequency is amplified and filtered through several stages and then mixed with another local oscillator frequency 455 kHz different from the first IF. This difference frequency is then treated just like the first IF on standard receivers. The purpose of the dual conversion is to increase the image and harmonic rejection or, in simple terms, make the receiver more immune to interference. This receiver is designed to operate in areas where, up to now, RC could not be flown due to TV or other forms of interference. The added noise rejection is not without penalty. The RF board parts count is nearly double that of the standard receiver. There are two crystals required. The whole receiver is more bulky despite miniaturization of components such as

(Continued on page 93)

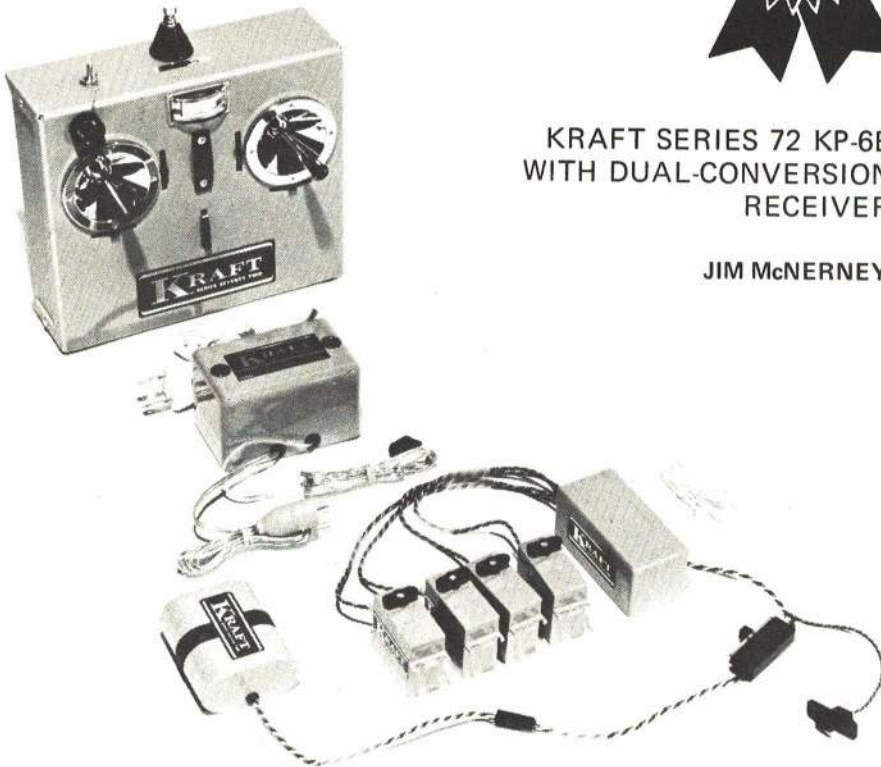

Above: Noticeable here is large 550 mah battery pack. Cells are new super-reliable high charge rate types.



Top left: Sterling Fokker was first of many models flown by the Kraft set this summer.

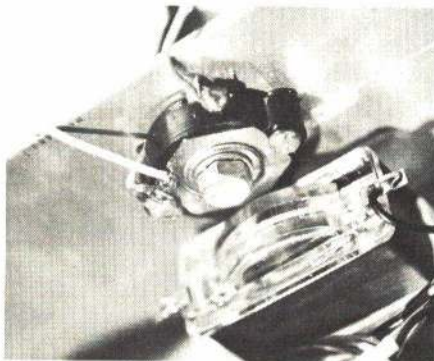

Bottom left: Antenna up and locked as described in text.

Below: Review set's receiver (right) shows abundance of components compared with standard receiver.

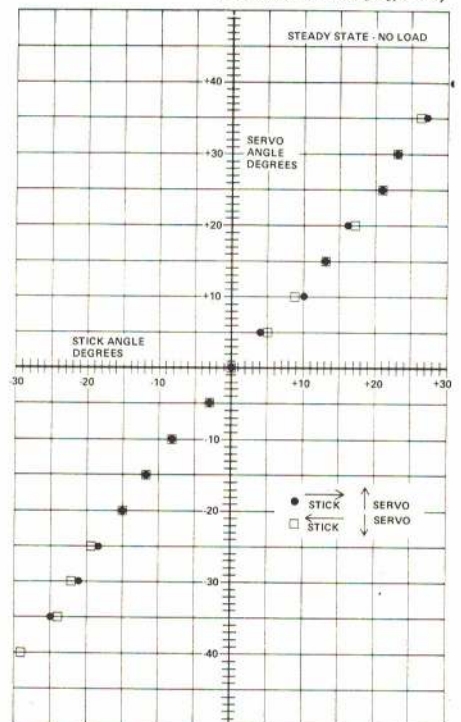
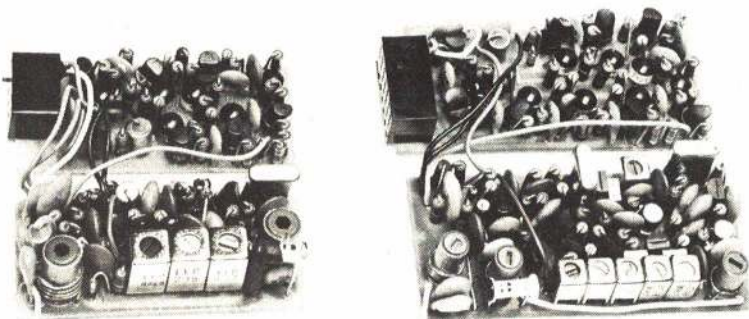

FIGURE 1 KRAFT SERIES SEVENTY-TWO KP-6B 8-15-72



CARL GOLDBERG

NEW! CG LOW BOUNCE WHEELS

With SHARP, CLEAN RIB TREADS
and TOUGH, LONG-WEARING HUBS

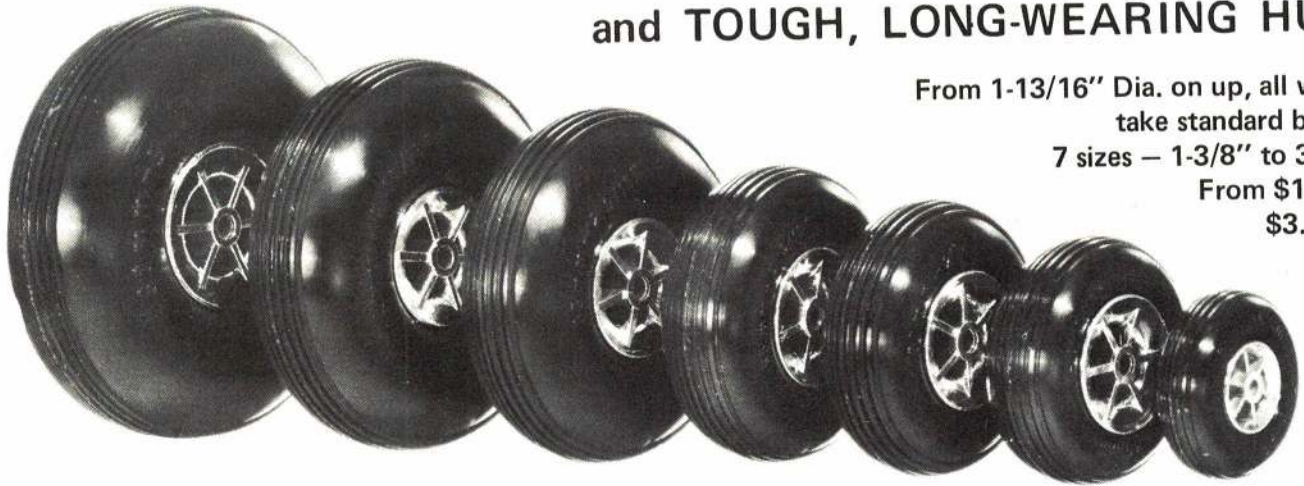

From 1-13/16" Dia. on up, all wheels
take standard brakes.
7 sizes — 1-3/8" to 3-1/8"
From \$1.89 to
\$3.19 pr.

Tested and proven in the field by famous fliers, we believe you, too,
will be well pleased by these very attractive new CG Low Bounce Wheels.
Ask your dealer to show you the size you want!

NEW! Spring Steel E-Z LINKS with 10" Rod

39¢ Each or 6 for \$2.25

New E-Z LINKS not only save you money, but are made of spring steel
and have quality threads that work smoothly without galling. The
rod hardness is just right, too — not too soft.

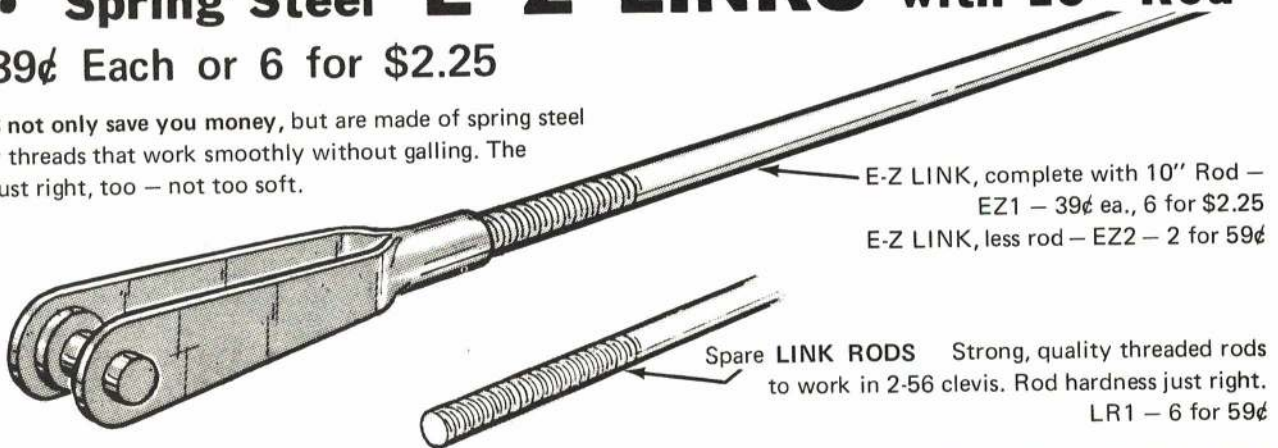

E-Z LINK, complete with 10" Rod —
EZ1 — 39¢ ea., 6 for \$2.25
E-Z LINK, less rod — EZ2 — 2 for 59¢

Spare LINK RODS Strong, quality threaded rods
to work in 2-56 clevis. Rod hardness just right.
LR1 — 6 for 59¢

NEW! Nylon TAILWHEEL BRACKET

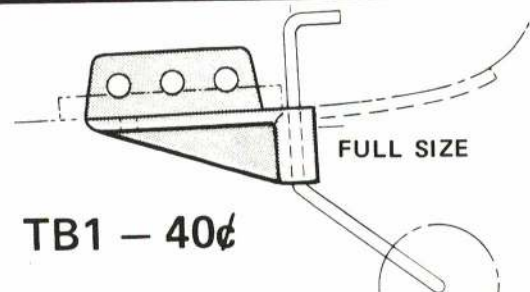
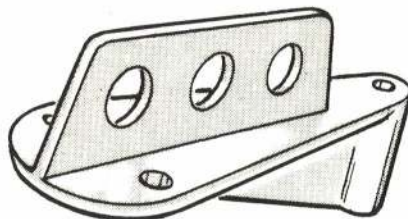

The simplest tailwheel mounting bracket yet — just cut
a slot in the rear bottom of the fuselage, smear epoxy
on the glue fin, and slide it into place.

TB1 — 40¢

AVAILABLE IN CANADA

P.S. For best service, see your dealer for items you
want. If not available, write direct; add 55¢ per item
(\$1 outside U.S.). Minimum order \$1.

CARL GOLDBERG MODELS INC.
2545 WEST CERMAK ROAD • CHICAGO, ILLINOIS 60608

CARL GOLDBERG MODELS INC.
2545 W. Cermak Rd., Chicago, Ill. 60608
I am sending 20¢ for 8 pg. Illustrated Catalog with "Recommendations in Starting in R/C." Basic Explanation of R/C Equipment, and Radio Control Definitions.

NAME _____
ADDRESS _____
CITY _____
STATE _____ ZIP _____



BLUE RIBBON REVIEW II

STERLING'S FOKKER— A BIG STANDOFF SCALE MODEL FOR CRAFTSMEN AND STUNT FLIERS.

ED SWEENEY

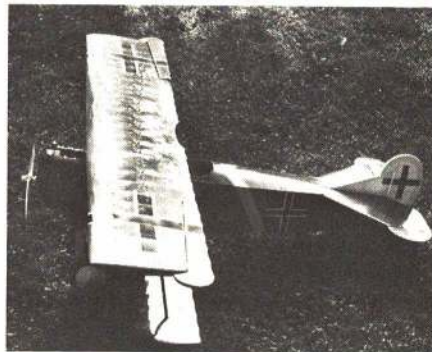

Top: Apparent here is the model's one major deviation from scale—symmetrical airfoils. These do mean a higher-than-scale airspeed but also allow lots of free-style stunting. Above: True of many WWI planes is the short nose, so all RC parts are moved as far forward as possible. Left: A pretty plane is often found with a pretty girl. Or is it the other way around? Below left: Engine is well hidden behind the metal and screen front cowl piece, yet gets plenty of cooling. A lead from the glow plug must be provided. Below: Exhaust is blown at an aluminum deflector. Nose gets messy after flying, so entire area is sealed with epoxy. Many details are neatly molded plastic parts.

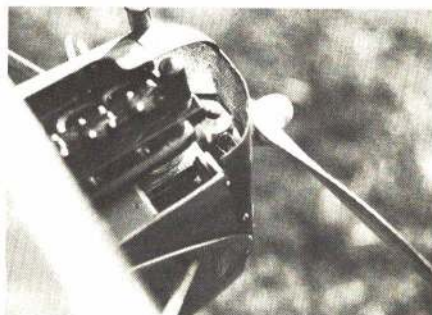
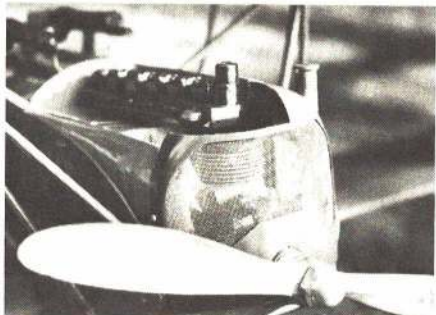

The Fokker DVII in this review was purchased at the Swap Shop at the 1972 Toledo trade show from its builder Darrell Turner. While we have no available comment on its construction, we have enjoyed flying it.

The plane is absolutely stock from the kit. It is covered with red Super MonoKote which was masterfully applied. The plane is surprisingly light. As we received it, it had been finished ready for engine and radio installation. Jim McNeerney, who reviewed the Kraft system, did this work. A Kraft 12 oz. fuel tank was fitted. Jim's only unique problem with equipment installation was to make some sort of exhaust deflector in the engine compartment. Light sheet aluminum was shaped and screwed to the firewall. At the tail, where the pushrods exit through the covering material, a patch of regular MonoKote was used for reinforcement.

What's the kit like? It has large plan sheets showing all details and sequential isometric views of various stages of assembly. A huge decal sheet gives the plane the markings seen in our photos. The structure is typically made up of many small pieces. While this means lots of detail work, it is also characteristic of any WWI type model. Offsetting this work is the excellent, light, vacuum-formed plastic parts for the machine guns, cowl sides, and engine cylinder head. Of course, if you were building a similar model for competition, you would make much more detailed versions of the same parts, but this plane gives the stand-off impression of much detail.

Being a stand-off scale model (it preceded the current popularity of stand-off scale by several years) there are some deviations from true scale. Most noticeable is the symmetrical airfoils. In the years this kit has been available, we've heard many comments, pro and con, about this. Sure it flies faster than scale, sure these large models are heavy, sure they could have a bigger engine, but our experience with it was that the airfoils are fine for Sunday stunting. One can perform outside loops, inverted flight and all kinds of rolling maneuvers. Because of the airfoils and high flying speed, the ailerons are very effective. This was a real surprise. It was expected that much aileron and rudder co-ordination would be necessary. But no, it rolls on ailerons and turns easily with aileron and elevator controls only. The only complaint is the rapid descent when power off. Even the best lifting airfoil won't make up for the high-drag of a big biplane so it is doubtful that the airfoils have too much to do with the plane's high sink rate. Spot landings and safe landings are a matter of learning the plane's glide angle and speed.

As with any high drag, heavy, and symmetrical airfoiled plane, a takeoff is not a matter of getting airborne then an abrupt climb out. That's alright for your pattern plane, don't do it on a large

(Continued on page 87)

Photo by Sam Chambliss



Holiday Offer

**The perfect gift
for a friend,
the family,
or yourself!**

ONE YEAR
12 BIG ISSUES
FOR ONLY—

\$6⁰⁰

SAVE \$3.00
OVER NEWS-
STAND PRICE

SAVE \$1.50
OVER REGULAR
SUBSCRIPTION PRICE



Plans and designs of all kinds. Great technical features. Full-scale articles and drawings. Enough Radio Control for the most ardent hobbyist. How-to-do-it articles and drawings for the TENDERFOOT. And WHERE THE ACTION IS covers the latest tricks, hints and kinks in free-flight, radio control and control line.

All this and more delivered to your door monthly at the low-low holiday price—if you subscribe now.

USE HANDY ENVELOPE—IT'S
ALREADY ADDRESSED TO US
—NO STAMP NECESSARY

Gift Announcement

SENT IN YOUR NAME

Be sure to print your name as donor on the envelope. We will immediately send an attractive gift announcement to the person you designate.

And a Merry Christmas to you too.

Love at first flight.

The crowd roars when Howie Keefe and his P-51D "Miss America" round the last pylon at the National Championship Air Races. Howie's that kind of crowd pleaser. And that kind of racing champ.

So is Cox's "Miss America," the exclusively authorized replica of Howie's P-51D. You'll fall in love with her the first time you fly this red, white and blue beauty.



Powered by the easy starting Cox .049 engine, the "Miss America" really goes because she has the same clean, aerodynamic lines that make the full size "Miss America" a champion.

Fly a winner, your own "Miss America." Available for under

\$14. at hobby, toy and department stores.

L. M. COX MFG. CO., INC.

A subsidiary of Leisure Dynamics, Inc.

1505 East Warner Avenue,
Santa Ana, California 92705



Send 25¢ for a full-color brochure of Cox gas-powered planes, cars, rockets and accessories. Address Dept. AA-12

ON THE SCENE

Cal Hawaii Summer Fun Fly

DON GUTRIDGE

Aloha! The only word with enough zing to accurately describe last summer's Cal Hawaii Fun Fly is "fantabulous." From June 24 through July 1 the BIRDs of Carson, California, and The Associated Modelers of Hawaii presented a no-tension, no-pressure good flying event. The casual and relaxed nature of the Hawaiian people set the atmosphere for the contests held at the Bellows air field near Honolulu. The long paved runway was lined with grass and shade trees. There was, a short walk from the strip, a beautiful white sandy beach with the prettiest transparent blue water.

During the pattern flying, winds up to 20 knots made takeoffs and landings difficult. The wind was mostly constant above 15 feet, but it was pretty bumpy near the ground. Even Joe Bridi was up-ended on one landing. Joe finished second in CX, Marty Barry first, Whit Stockwell third, and Bob Smith took fourth with a borrowed plane—his number one ship encountered a tree during practice. Bill Cranston of Phoenix was first in CN, Dick Glynn second, and

Mexico's Marcial Davila third. The first three places in Class B went to Arlen West, James Miura (Hawaii), and Edie Keefe.

With 15 entries each, Class A Pattern, Sport Pylon, and Formula I were the most popular events. Walt Monson, Don Gutridge, and Joe Zingali were the top three in Class A. The Sport Pylon boys got a break—only a six knot breeze blowing. This provided some very good times and no major mishaps. Arlen West, George Duerksen (Hawaii), and Joe Martin headed the list of pylon winners. John Brodbeck came out on top in Formula I. He also turned in the fastest time at 133.2. Chuck Smith came in a very close second, Joe Martin third, and Marcial Davila fourth.

At the Awards Banquet, attended by 120 people, the line-up on the trophy table was impressive. Hand carved trophies were presented to fifth-place winners with a flower lei and a kiss from Sharon Vandewalker.

Hawaiian Holidays provided a tour guide named Chuck who did a fantastic job. Everyone asked that he join us next year in Mexico City. In addition to making extra tours available, Chuck helped with the Island's night life. We even got him out to the field to try his hand at RC, and he didn't do badly. He said he might bring a plane to Mexico.

Ninety modelers on United's Friend Ship took over the plane to and from Honolulu, setting some kind of record. Plans are already in the works for next year's vacation context in Mexico City, details on request. Adios amigos!

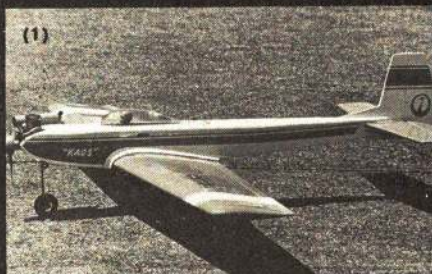

(1) Well-finished Kaos by Jim Miura. Jim placed second in Class B. (2) Arlen West, assisted by Ed Keefe, prepares to tach up. (3) T2A flown by Marty Barry and Bob Smith. (4) Sport Pylon was enjoyed by all. Here, Ben King comes out of No. 3 as Whit Stockwell makes it around the No. 1 pylon. Lap counters kneel out of the way. (5) Gary Johnson (foreground) our CD, alias "The Great White-Kahuna," reclines to read first round results as his assistant prepares judging assignments. Mountains in the background looked close, but were some distance away. (6) Marty Barry does a spinner start on his T2A. Marty was first in CX.

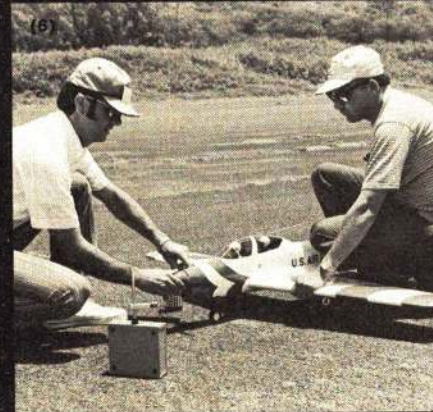

PLANE ON THE COVER:

Model that won the '71 CL Nats and was 6th at the '72 CL Scale World Champs is patient project of a great plane. Has many operating features and flies quite well.

Vickers-Supermarine

MALVIN MEADOR

Photos by Bill Boss and the Author

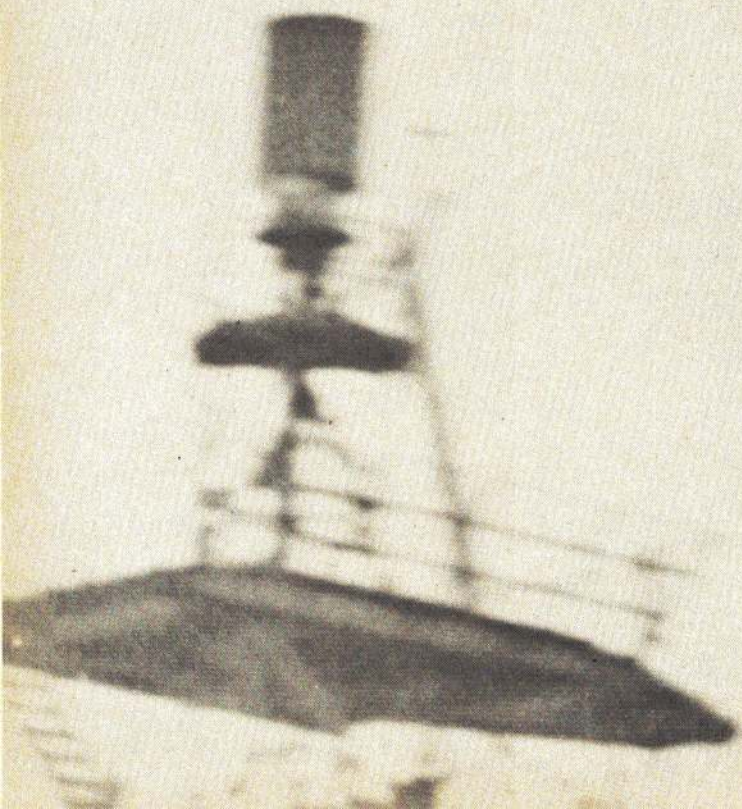



ne Spitfire Mk IIA

Every Scale builder has a favorite airplane or type of airplane; I've always been inclined toward World War II military aircraft. After moderate success in local scale contests, I decided to build a ship for entry in the 1971 Nationals. To do this, I needed a subject which inspired me to invest the amount of time required to complete a competitive scale model. Retractable landing gear—an operating feature having good spectator appeal and a high scoring flight demonstration option—was a must. Another point relevant to selecting a subject was additional operating features such as flaps, sliding canopy, navigation lights, drop tanks, etc., which could be incorporated. Also, I wanted to stay away from subjects which had been overdone.

One aircraft kept coming to mind, the Supermarine Spitfire. It was one of the most famous World War II fighters, plenty of reference material was available and, despite its fame, it didn't enjoy much popularity with modelers. The Spitfire had enough operating features to insure a respectable scale flight score, and it featured very simple retractable landing gear which could be

easily adapted to Bill Johnson's efficient, lightweight Centrak gear retraction unit. Using this system would eliminate the mess of batteries, extra control lines, electrical wiring, and other assorted headaches which go with retractable gear in control line models. Also, the simplicity of the landing gear would make it fairly easy to machine scale shock absorbing gear struts for added realism.

While considering the positive and negative aspects of the Spitfire as a flying scale project, one nagging thought kept coming to mind: The extremely short nose moment, small empennage areas, and fore and aft placement of the landing gear on the prototype could make the model's flying characteristics less than satisfactory. However, after reading a very scientific conclusion that "anything will fly on control lines," I decided to proceed with construction. The resulting model did fly satisfactorily, but it is definitely not a beginner's ship—the Spitfire demands the flier's undivided attention from takeoff to the end of the last taxi lap.

Which variant of the Spitfire to build was the final problem. The solution was

dictated by the availability of reference material, and I settled on the Mark IIA depicted in *Profile Publication*, No. 41. Several variants of the Spitfire shared a basic airframe; it is simple to convert the Mark IIA to a Mark I, III, or V, and substitution of four 20mm cannons for the inboard .303 caliber machine guns converts the model to a Mark IIB.

Before beginning construction, study every available publication on the Spitfire to become familiar with details of the prototype. I found the following references to be particularly helpful: Bruce Robertson's *Spitfire: The Story of a Famous Fighter*, and *Aircraft Camouflage and Markings, 1907-1954* both available from Harleyford Publications; *Profile Publications*, Nos. 41 and 166; Aero Publisher's *Supermarine Spitfire*; and Willis Nye's excellent drawings of the Spitfire. These publications contain many drawings and photos invaluable for detailing the model and preparing the proof of scale presentation which must accompany it in competition.

Construction may be greatly simplified with installation of conventional non-retractable gear. However, the satisfaction of seeing the wheels disappear

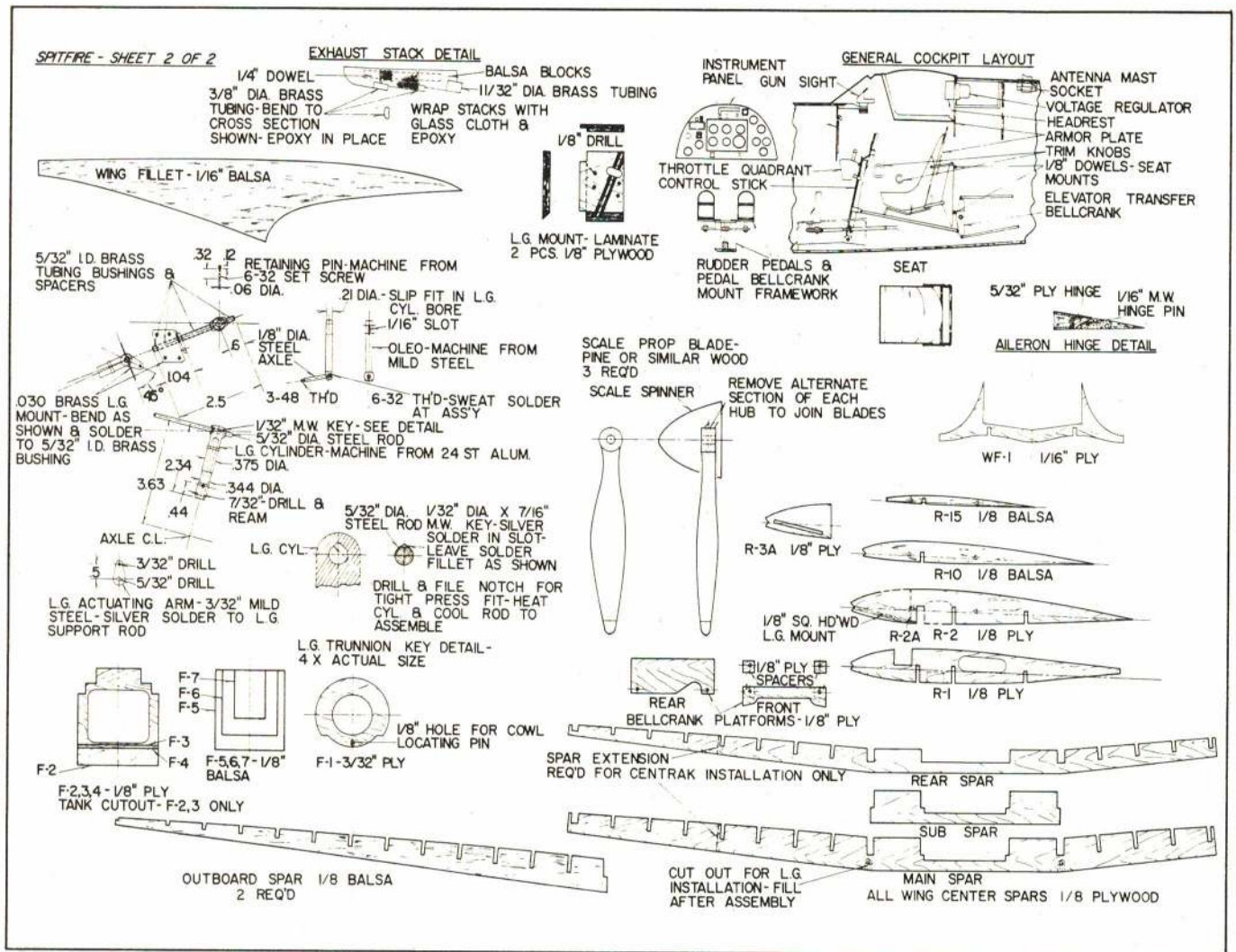

At Nats, Malvin won scoring 517 points. He also won Sterling Award for highest static points.



into the wings shortly after takeoff makes the extra effort worthwhile. If you use the Centrak installation, contact Bill Johnson, 2504 Charwood St., Charles, Mo. 63301. Bill is familiar with the model and can supply the retract unit and complete instructions for installation and operation.

Construction

The landing gear is the most complicated component and is a good place to begin. The gear struts are turned from aluminum stock and a 7/32" diameter bore drilled and reamed for the oleos. Drill holes for the oleo retaining pin and the gear support rod, making sure the centerline of each hole is at the proper angle (see plans). This is necessary for correct tracking of the wheels and for maintaining correct gear geometry during retraction.

The oleos are machined from mild steel (I used 5/16" steel bolts), and the axles are 1/8" music wire threaded on both ends and silver soldered into tapped holes in the oleos. Exercise caution when drilling the holes in the oleos to insure correct alignment of each strut to the shape shown, and assemble

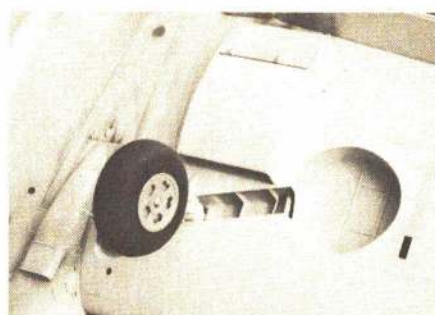

Above: A Bill Johnson Centrak gear is used. At speed in flight, centrifugal force working against a spring raises the gear. Very reliable. Above left: Nice facet of real plane was its plywood covered wings. Detailing is complete without yards of rivet lines. Left: With flaps down one sees even more detail, including flap position indicator finger which lifts through a cover on wing top surface. Oil cooler door also operates.

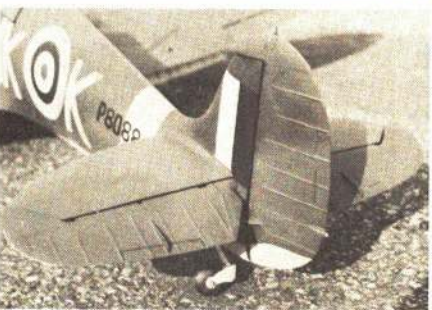
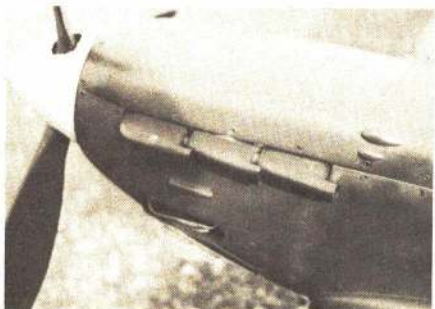
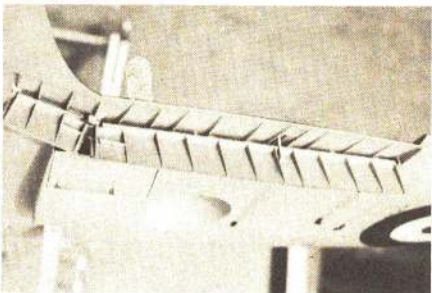

Above: All smooth areas of the model are fiberglassed, including some detail items such as simulated exhaust stacks. Above left: Before surface finishing, cockpit interior is completed. Door hinges open to reveal many more details, note canopy slides back. Left: All control surfaces have simulated fabric covering. Note full swiveling tail-wheel.

Model duplicates a real life plane known as The Borough of Lambeth



the struts and gear support rods, keying in place as illustrated in the plans. Fabricate the spacers, bushings, and mounts from brass tubing and sheet and the gear actuating arms from mild steel; assemble, making certain that the gear mounts rotate freely on the support rods and that the actuating arms are silver soldered in place at the correct angle. Selection of springs for the oleos depends on the final weight of the model and the amount of shock absorbing action desired. The oleos can be removed easily, so experimentation with various springs presents no problem.

One further note on the landing gear: If the Banner wheels shown on the plans are used, the aluminum hubs must be faced off on each side to give a thinner contour and allow the gear to retract fully into the wheel wells.

The wing contains almost all the gear, flap, and other control operating mechanisms and is the next component to build. Cut ribs R-2, R-10, and R-15 to shape and drill 1/8" holes in each one at the location shown on the plans. Stack the correct number of 1/8" balsa rib blanks in sequence with the pattern ribs, using 1/8" dowels to maintain alignment. Shape the stack of ribs in the usual manner, with one exception: The stack should show a curve, top and bottom, from the root to the tip rib. This is because the upper and lower wing surfaces are curved as viewed from the front.

Join the balsa wing spars and plywood doubler, and glue the ribs in place on the spar. Use two 20" lengths of 1/8" doweling in the holes previously drilled in each rib to maintain rib alignment until the glue dries. When dry, notch the ribs and install stringers for the flap wells and aileron cutouts.

The bottom surface of the outer wing panels should be sheeted next. Leave the bottom center section open until the wing is in place on the fuselage and all control linkages are hooked up and operating properly. The flap and aileron wells should not be cut out until the tops of the outer wing panels have been covered and the wing sanded to shape.

Cut the openings for the landing gear wells in the bottom of each wing and remove sections of ribs as required. Then line the wells with 1/16" balsa. To install the landing gear, it is necessary to cut a small hole in the wing bottom sheeting between the leading edge and front spar. Before final gluing of the plywood landing gear mounts, check gear alignment carefully both in the extended and retracted position.

Mount the Centrak unit with the Roberts Flight Control, control line leadouts, and control linkages attached. Bend and install the 3/32" music wire gear actuating arms. Be certain that the rods are the correct length to actuate both gear simultaneously—they must both be full up and full down at the same time. Install the Centrak springs, leaving the end which attaches to the control unit free. This will allow for movement of the landing gear to check

(Continued on page 80)

The Easy Art of Dethermalizing

BOB STALICK and JACK SHAFER



There it is, up high against the blue sky—your first free flight. The engine has stopped, and it's still climbing. You spent hours and hours and some hard-earned dollars to get it up that high. Now what? If it has a dethermalizer, you've got few problems except for a walk to where it lands. If you don't have a dethermalizer, it may not be down for an hour or more—and where will it land? Someone, somewhere, may find it and, reading your name on it, call or write. If not, it's time to start another or, worse yet, decide that it just isn't worth the trouble.

Don't despair. Of all of the devices developed by free flighters, the dethermalizer, or DT, is the simplest and most reliable method of bringing the model back for more flying. Over the years, many dethermalizer devices, from spools of thread tied to a wingtip to parachutes, have been tried, but the most effective and popular one yet developed is the pop-up stabilizer.

How does the pop-up stab work? When the plane is in its power or glide phase, the stab is held in its proper position with rubber bands; when it's time to DT, the stab pivots on its leading edge and raises its trailing edge about 45° with rubber band tension. The effect of this is to slow the glide down and stall the model causing it to descend gradually.

There are several different and satisfactory methods of rigging a DT system. This article illustrates some of the more usual systems. Differences of model style dictate how each system should be hooked up. Let's investigate exactly what needs have to be met in a good DT hookup.

The leading edge of the stab must be held down on the stab mount, usually under tension of one or two rubber bands attached to wire hooks on the top of the stab and then looped under the fuselage and around back to the hooks on the stab. The rubber band should

have enough tension to lift the stab to a DT angle. If it doesn't, increase tension by using more or larger rubber bands or move the stab hooks to another location to get more leverage.

To hold the trailing edge down before DTing, use another rubber band which is strong enough to offset the tension of the leading edge bands.

A string of wire is needed to limit the amount that the stab can pop up. I prefer strong braided cotton, 40 lb. test fishing line—not nylon. The line should be tied off between the stab and fuselage to allow a 40° to 45° DT angle.

An actuating device, usually a DT timer, is necessary to time the length of the flight so the model can be brought back down. A timer, such as the Tatone, is available from most hobby shops for about \$5. A fuselage which when lit burns at a steady rate until it severs the rubber band holding down the trailing edge can also be used. The Sig Manufacturing Co. makes one; it is available

Bring 'em Down Alive!

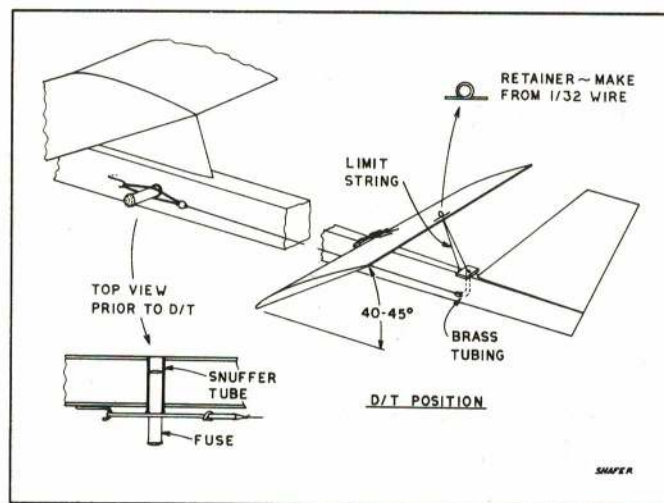
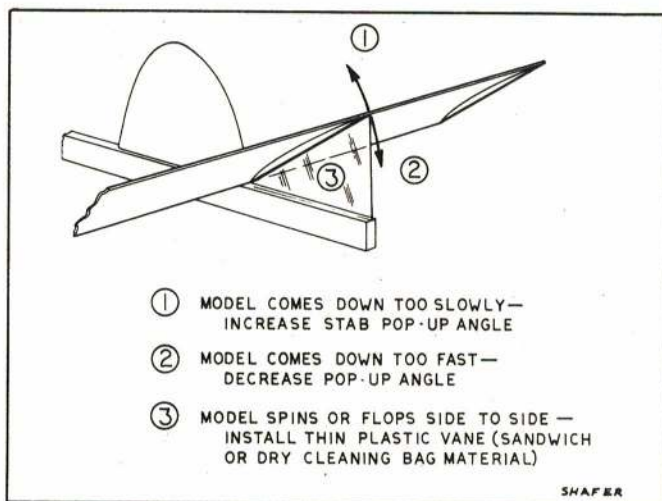
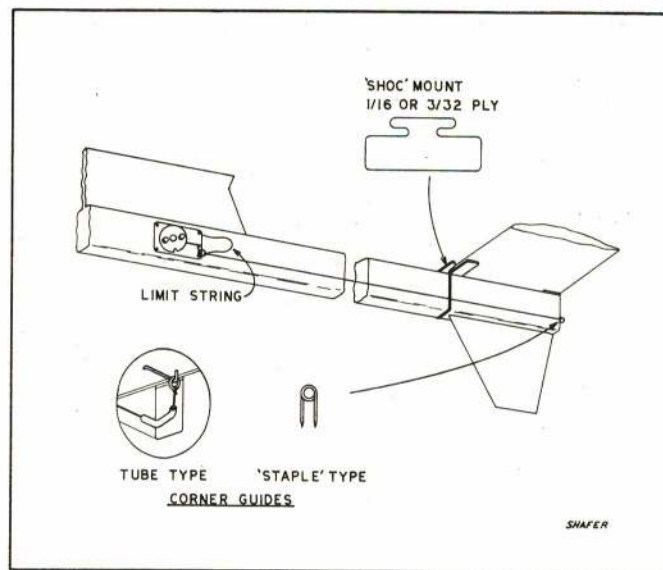
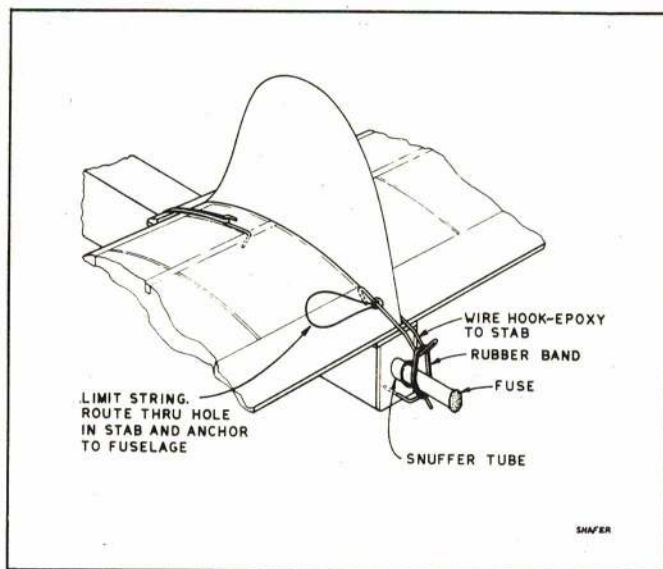

from many hobby shop. Cotton indoor clothesline or venetian blind cord can also be used, but it is generally not as satisfactory unless soaked in a solution of potassium nitrate to guarantee burning.

The AMA requires a snuffer tube to put out the glowing fuse on any competitive fuse-equipped model. This is usually a short length of 1/4" aluminum tubing fastened either to the tail or in the fuselage so that the fuse will be put out after it burns through the rubber band and the stab will pop up.

To take up some of the landing shock, add wheels or a landing skid. Though this is not entirely necessary, models can develop a fair speed when descending from a high altitude. The skid is usually a piece of four in. long wire—1/16" dia. for a 1/2A size model—which sticks out from the bottom of the fuselage and is fastened to the firewall. Some models use a rubber bumper or a piece of plywood, but the wire is probably the best.

Study the sketches and pictures before mounting a DT system on your free flight. After installation you may, nevertheless, find yourself with a number of problems. If all the sketches have been studied and followed, the only problem

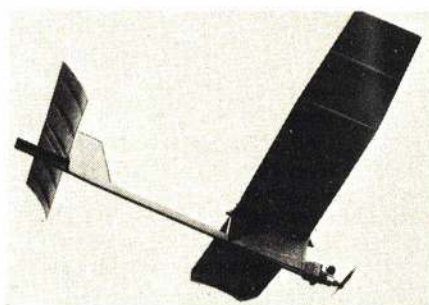

Side/bottom view of a Mini-Rod (February 1969 AAM) under full DT coming to earth.

would be whether there are enough rubber bands to pull the stab up to the proper angle or hold it in place while the engine is running. A good ground test should be conducted before taking the model to the field. Check that the fuse burns through the retaining band and that the stab pops up all the way when released. Correct any malfunctioning. Now take it to the field. You are ready for a typical contest flight.

First rubber band the wing and stab into position; check that the rubber tension is right. Next, check the alignment of the wing and stab—everything should be in place. Fuel it up, check the glow

plug, and see that the stab rests firmly on its mount. Cut a four min. length of fuse (about two in. of Sig fuse), insert about 1/2 inch into the snuffer tube between the rubber band loop. This allows about 3 1/2 min. of burning time before DT. Check that your engine timer is operating accurately; then get your official timer. After checking the wind and thermal activity, choose the right time to launch. Start the engine, light the fuse, and release the engine timer and model. Watch the flight, knowing that after 180 seconds of flight time the model will safely DT to earth ready for another flight.

Never make the mistake of even test flying without using the DT system. More models are lost in non-thermal air without DTing than not. Better to be safe than sorry. If you have difficulty lighting the fuse, bore a hole in a Band-Aid can and epoxy a short container of 1/4-in. tubing into its side to make a fuse lighter. This is a perfect weathertight container in which to hold the fuse, and the fuse end sticking out of the tube can be lit before starting the engine. The fuse in the can will go out when it strikes the can's snuffer tube.

Now, it is time to go out and catch yourself some thermals. They're out there waiting. Happy DTing.

David

*"Oh! I have slipped the surly
bonds of Earth
And danced the skies on laughter-
silvered wings;
Sunward I've climbed, and joined
the tumbling mirth
Of sun-split clouds."*

John Gillespie Magee, Jr.
High Flight

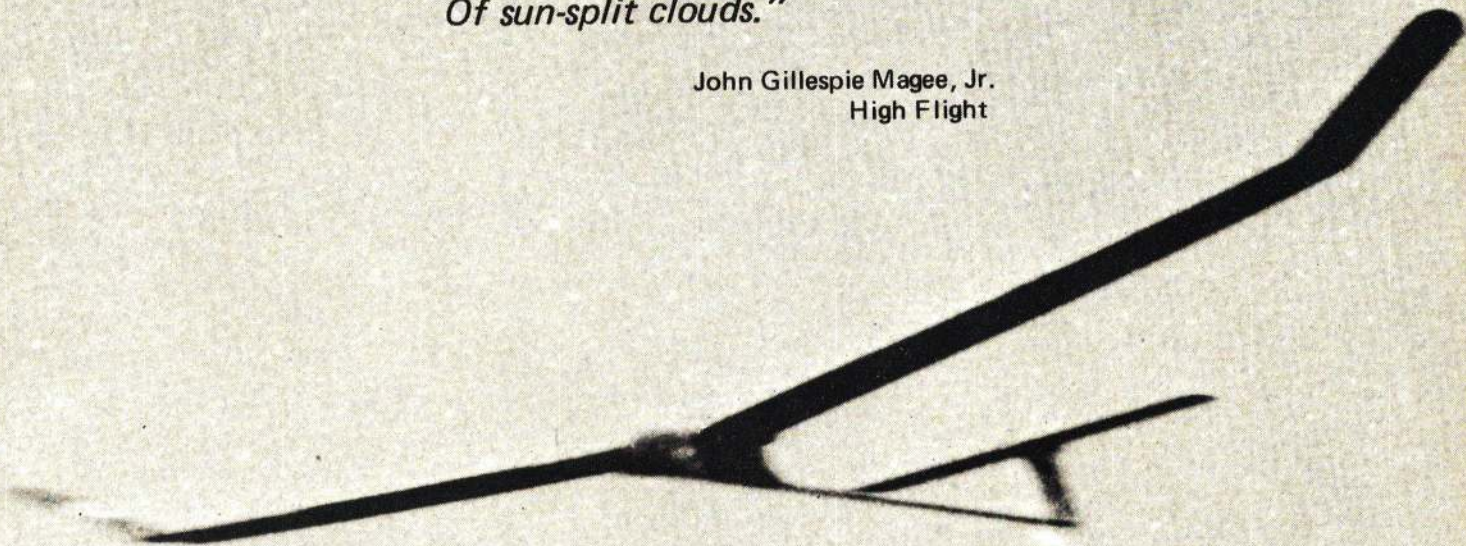

HERE'S AN A-1 SIZE NORDIC THAT CAN TAKE ON THE A-2 AT ANY MEET

JOHN THORNHILL

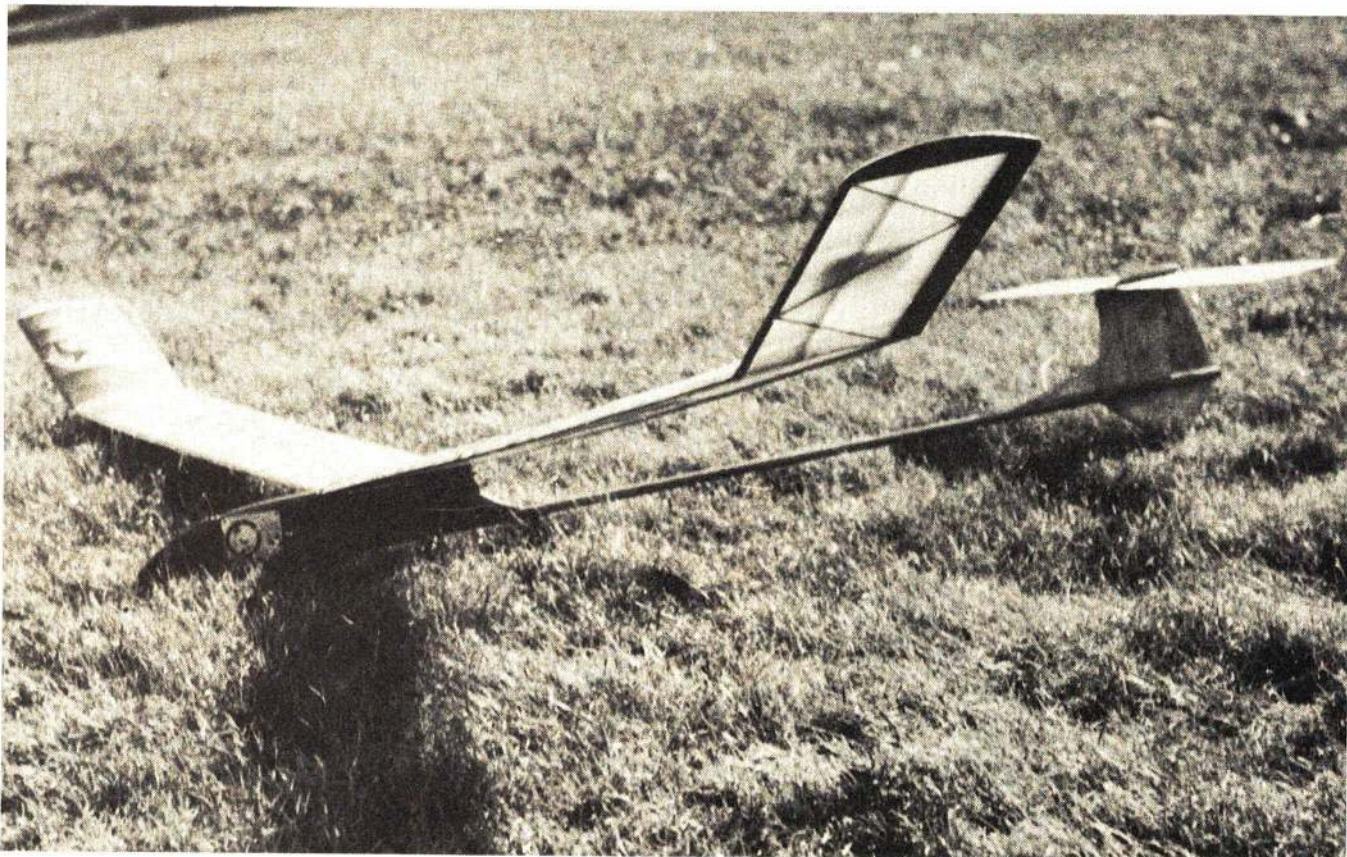

The end of a long flight without DT.

With David I have tried to design an A-1 ship which can compete with and out-fly the larger A-2s. At the same time, I also wanted a nice easy-to-carry sport ship.

Free flight contests usually include towline events. At the Nationals, the second most popular event is Nordic A-1, A-2 combined ($\frac{1}{2}$ A Gas is the most contested single event). Most fliers, thinking that a larger ship has a better chance, go with A-2s. Often this has proven to be true, but I believe an A-1 can be built to fly with and beat A-2s. David is my idea of such a ship.

Let's look at the two classes:

	A-1	A-2
Total Area	279 sq. in.	527 sq. in.
Min. Wt.	5.08 oz.	14.46 oz.

A little math will show that the A-1 has over one half the area of an A-2, but its minimum weight is just over one third that of an A-2. The result is much lower wing loading for the A-1.

I have never seen a thermal, but I fly a lot and watch buzzards up here in the country. I believe a typical thermal on a typical day is small within towing

limits—50 to 75 ft. dia. There is a relationship between wingspan and minimum turning radius. A shorter wingspan allows the ship to be adjusted to fly in smaller circles, as compared to an A-2, and these smaller circles can hang a ship in small thermals close to the ground.

Other advantages for an A-1 are: lower cost, easier building, and higher strength weight ratio.

Don't let the flat bottom airfoil put you off. A flat bottom section is not out of place with this wing loading and cord. A flat section is easy to build and rigid at low weight. With a stable section, a small (16%) stab can be used and a better overall glide is possible.

Looking at the plan you see simple shapes. Square tips do not hurt performance and also make it easy to prove that the ship is not oversize. With the 15:1 aspect ratio, the ship looks much larger than the average A-1.

Construction

With some experience, David is not difficult to build. Picking out the wood is quite important. Try to get straight stock at your hobby shop, or send away to Sig Manufacturing Co. Straight wood is more important than light wood as warps are difficult to get out. The trailing edges should be the same

weight. Try to build carefully, and don't be frantic about the weight.

To check the finish weight, try this: Nine new pennies weigh very close to one oz.; a finished David, including balance weight, should weigh no less than 61 pennies.

I used jap tissue to cover the wing. The fuselage is made from a 1/4" sheet and a fiberglass arrowshaft. Purchase an arrow from any sports shop and discard the head and feathers. For the 1/16" square parts, make the stripper shown on the plans. The stab is a simple sheet with some ribs. The strange shape of the rudder grew during flight tests since I had to add area to get the proper tow. The large rudder controls the long wing. The rudder shape can be modified as long as the total area remains the same. Use some DT or your new ship will fly away as soon as it is trimmed out. Light monofilament nylon should be used for flying since there are no pull tests for A-1s.

Cost, not including the timer, is about four dollars. I've built two: one with a fuse and one with a tickoff. I think that for fun flying, the fuse is fine.

I found David a personal joy. It flies as well as most A-2s. Build one and have a fling at the giant A-2s.

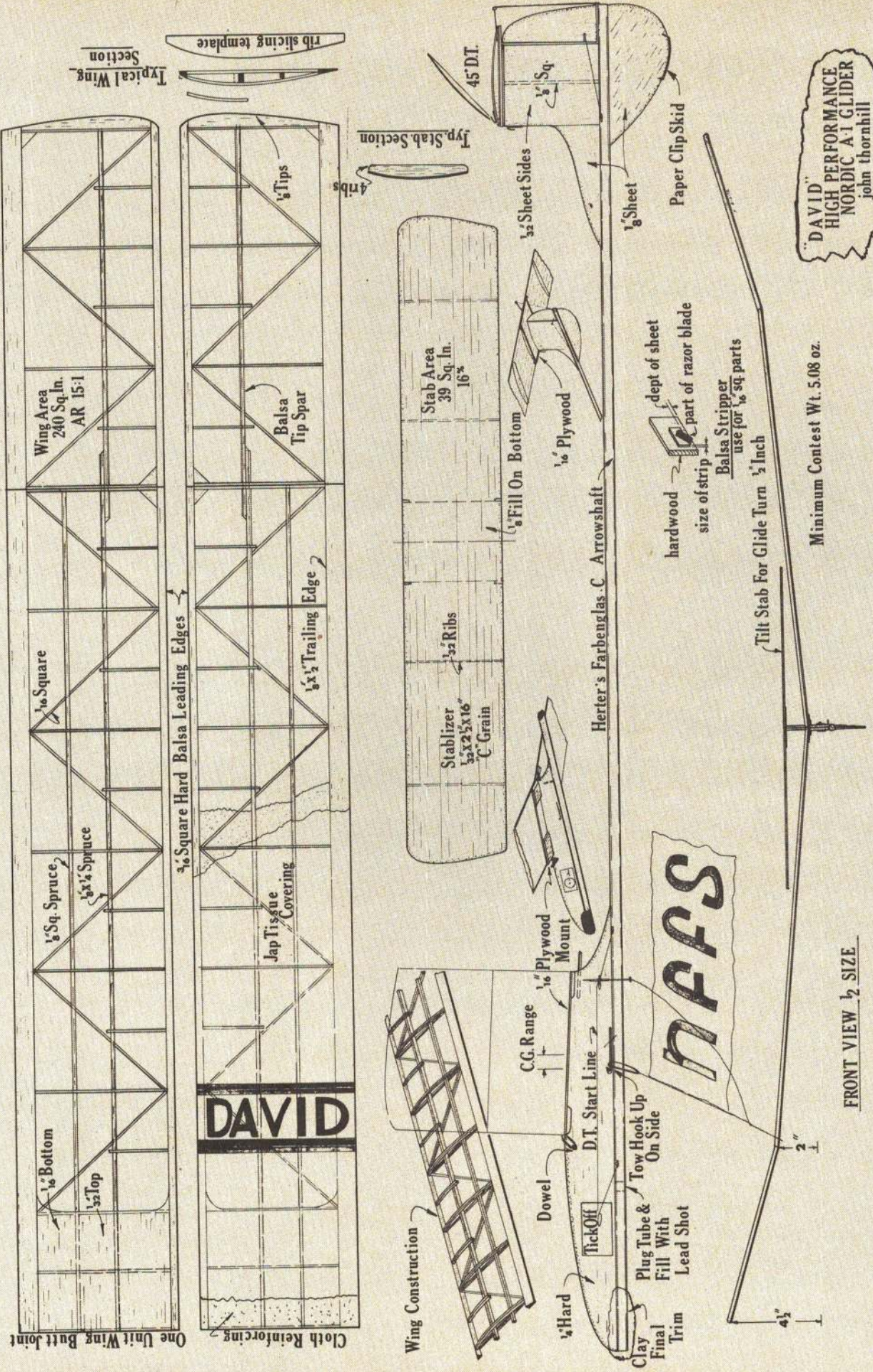

"DAVID"
HIGH PERFORMANCE
NORDIC A-1 GLIDER
John Thornhill

Minimum Contest Wt. 5.08 oz.

FRONT VIEW 1/2 SIZE

**When swastikas suddenly replaced
the sport plane stripes in 1935,
the He-51 was revealed as a first-line
German fighter**

DON BERLINER



Heinkel's Prettiest Biplane

What would have happened if . . . World War II had started four or five years earlier?

No one will ever know, of course, but it's a good subject for hangar flying on those cold, wet days when flying things and people have to remain on the ground. If the computer simulation guys, who have matched Muhammed Ali with Jack Dempsey and Babe Ruth with Sandy Koufax, ever decide to cram all the available data into their thinking machines, we could get a pretty good idea of what it might have been like, and who would have won.

But you don't even need an adding machine, let alone a computer, to tell you that it would have been totally different. The airplanes that were on hand in the mid-1930s were as much like World War I fighting craft as they were like the machines which were actually to do the fighting. The war would have been much less destructive, and probably a lot more glamorous as a result.

For one thing, the Germans would not have entered combat with the huge advantage of real and imaginary technical superiority. They would not yet have built hundreds of Messerschmitt 109s, nor would the hoax exist that a modified '109 was the airplane that had clocked 469 mph in a speed record run. They would not have built a few He-112 fighters and then created a propaganda operation around the tricky He-100 prototype, after the impressive early production '100 had been shot down by the politicians.

In place of some truly fine aircraft, the Germans might have been forced to go to war in Heinkel He-51s, and the world might have been spared a lot of misery. An indication of some of the differences can be gained from a study of the Spanish Civil War, which was a trial run for the Germans, Italians and Russians. Not a simulation, exactly, but a way of trying out new ideas and equipment without risking everything.

One of the first and most surprising lessons learned was that some Russian fighters were better than some the Germans were using. A few years later, the tables were turned. But in 1936, they were clearly ahead.

One of the reasons was the Allied insistence that Germany build no combat airplanes of any kind, in hopes that a repeat of World War I could be avoided. This undoubtedly slowed aircraft development in Germany, at least for awhile, but it hardly stopped it. In the early 1930s it was pretty apparent that the Germans were building warplanes and training military pilots, but calling it a sport plane movement. The wraps were finally taken off in March 1935, and the tail stripes on "sport planes" were replaced with a black band enclosing an ominous swastika.

One of the main types to undergo this change was the Heinkel He-51, an especially attractive biplane that probably would have been better off had it remained a sport plane. But the goal of the Third Reich was world domination, and everything else had to take a back



Photos Courtesy of Smithsonian

The first of hundreds. The He-51a prototype sits on its gracefully streamlined landing gear, drinking fuel and almost ready to fly.



The standard production version of the He-51, showing its unequal-span wings and out-swept interplane struts to good effect.

One-third of the nine-plane pre-production run of He-51A-0 fighters, still carrying civilian markings used by the secret Luftwaffe.



(Continued on page 74)

PLANS ON FOLLOWING PAGE

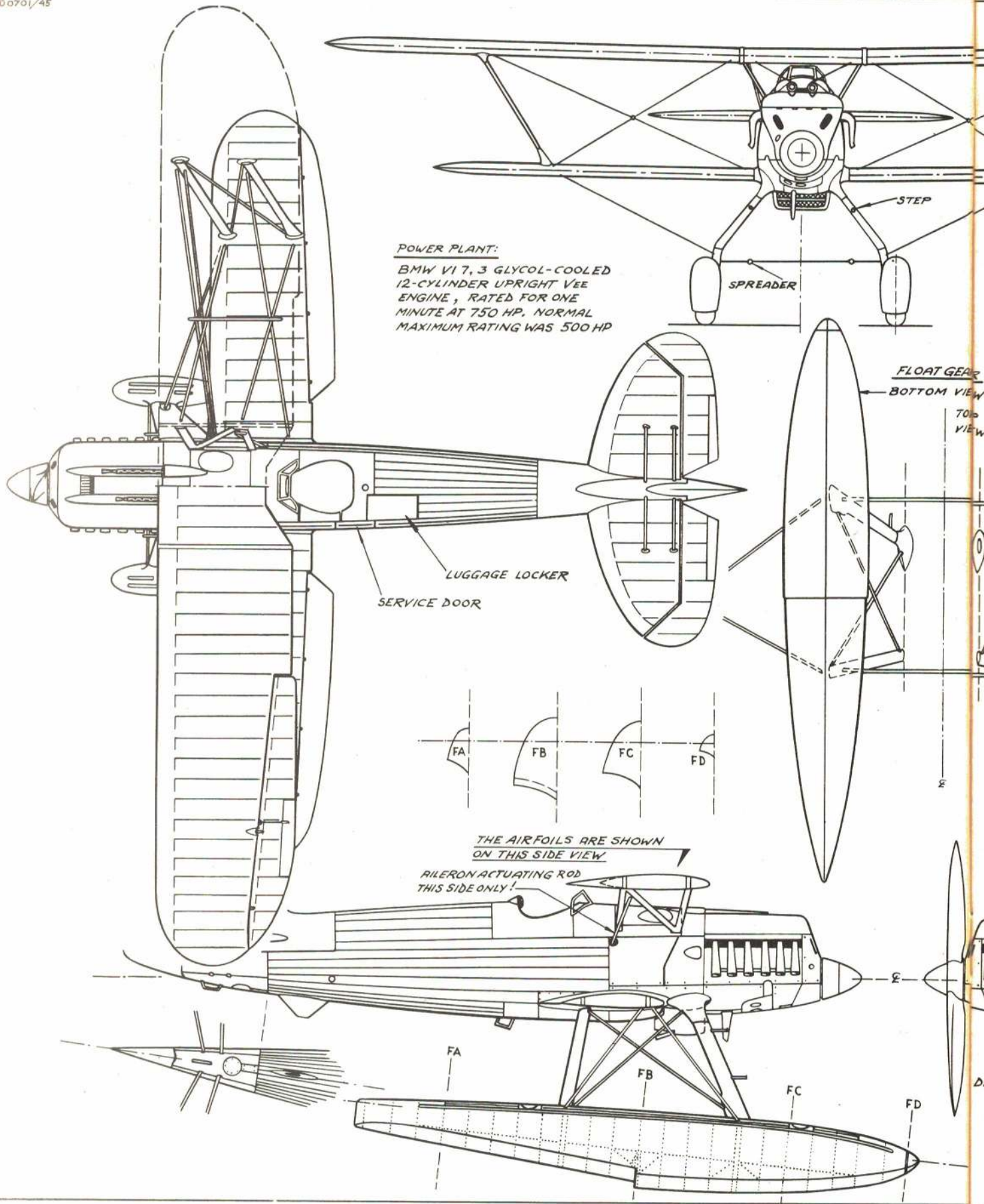

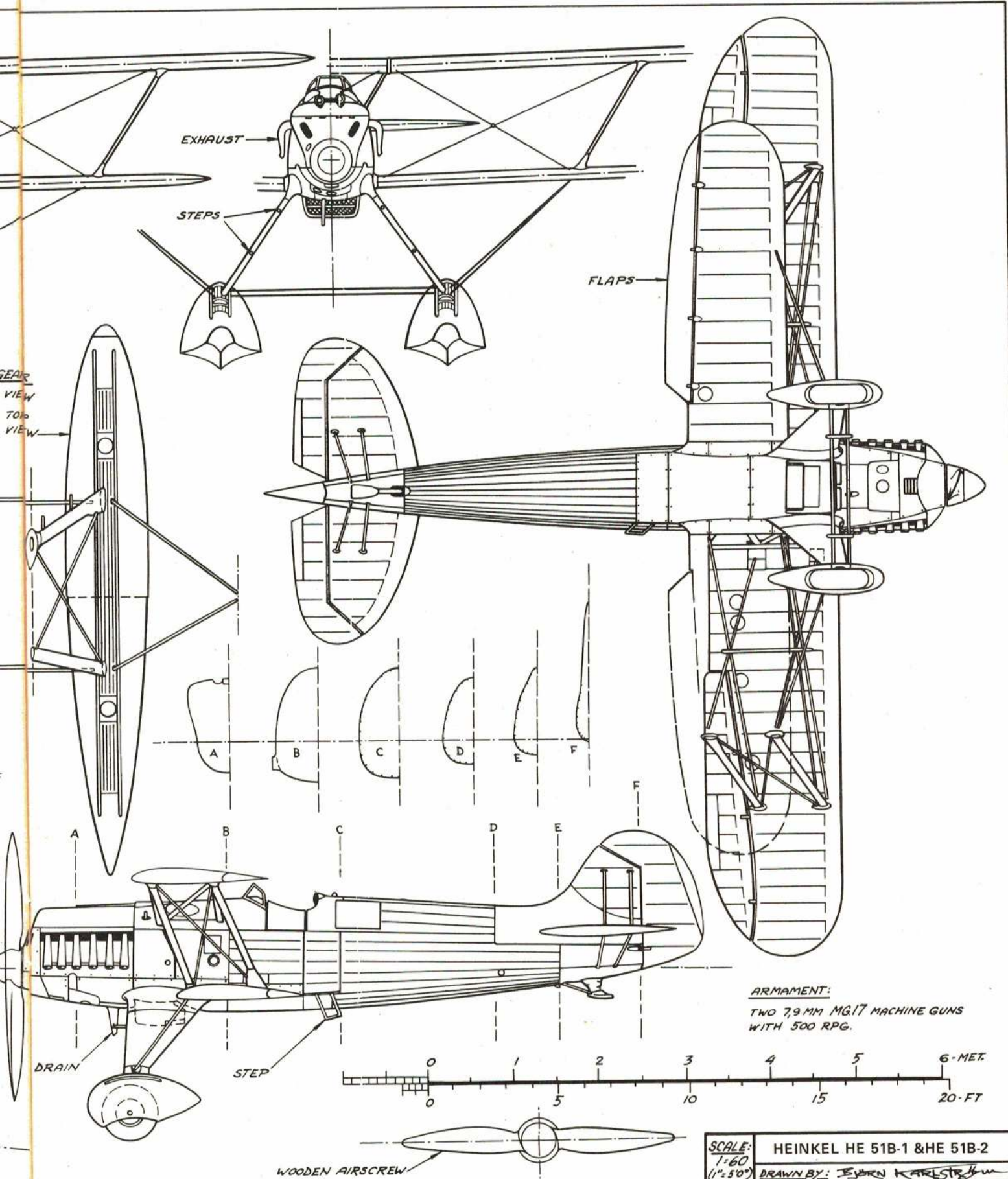

ARMAMENT:
 TWO 7.9 MM MG.17 MACHINE GUNS
 WITH 500 R.P.G.

QUICKY 500

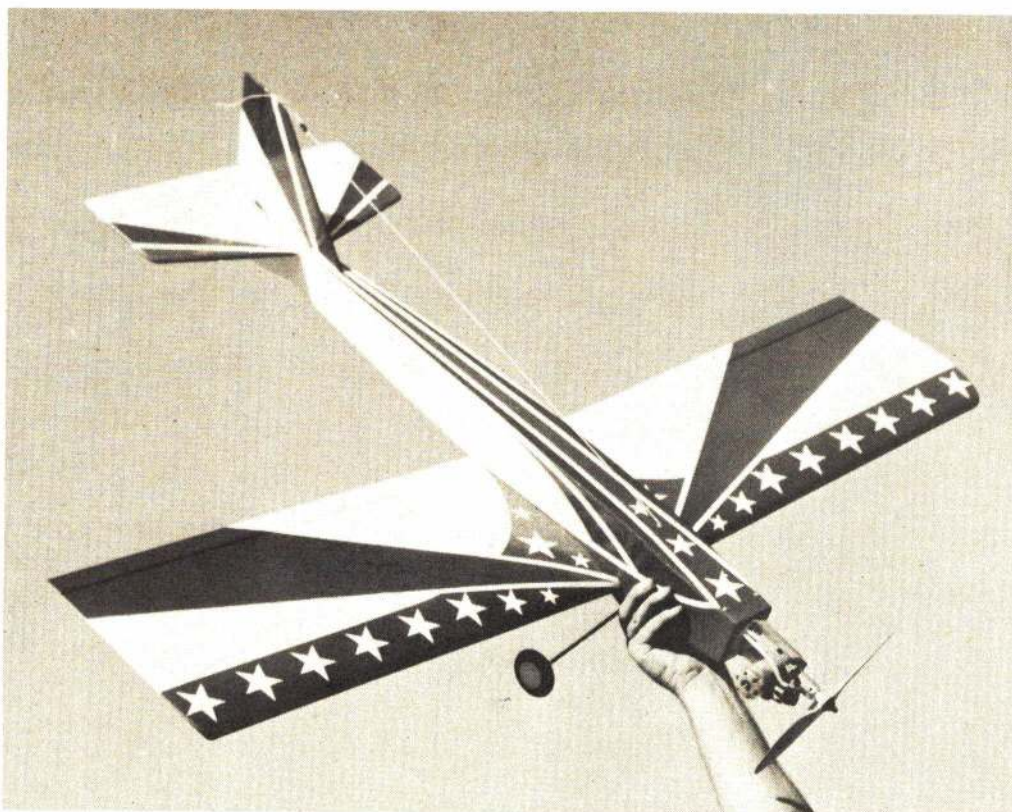

CLUB PYLON RACER:

ONE-DESIGN PYLON RACER
FOR BEGINNERS AT RACING OR TO TEST
ONLY THE FLYING SKILLS OF THE EXPERTS.
A FINE SPORT FLYER TOO, BUILDS QUICK,
FLIES LIKE A DREAM.

GLEN SPICKLER

The story behind the "Quicky 500" goes back to about a year ago when several members of the B.A.R.K.S. (Bakersfield Aircraft Radio Kontrol Society) approached me to see if I was interested in drawing up a one design club racer. Some of the members were holding impromptu races with their stunt type models. Due to the large variation in speed because of differences in design, they were not proving too much in the way of individual flier's ability. What the fellows wanted was a simple "40 Size" airplane that would be economical to build and easy to fly.

The idea sounded interesting, so out came the drawing board, paper, pencils and a large size eraser. Thus, the "Quicky 500" began to evolve. A model for just one purpose has a limited appeal, so it seemed only sensible that the "Quicky 500" should also be capable of the everyday fun flying that the majority of Radio Control modelers enjoy. The success of this approach has

Above: Stars and stripes, would you believe—red, white and blue? Each club can standardize the engine to be used.

*Four color photo by
Fords Photography, Bakersfield, Ca.*



KRAFT

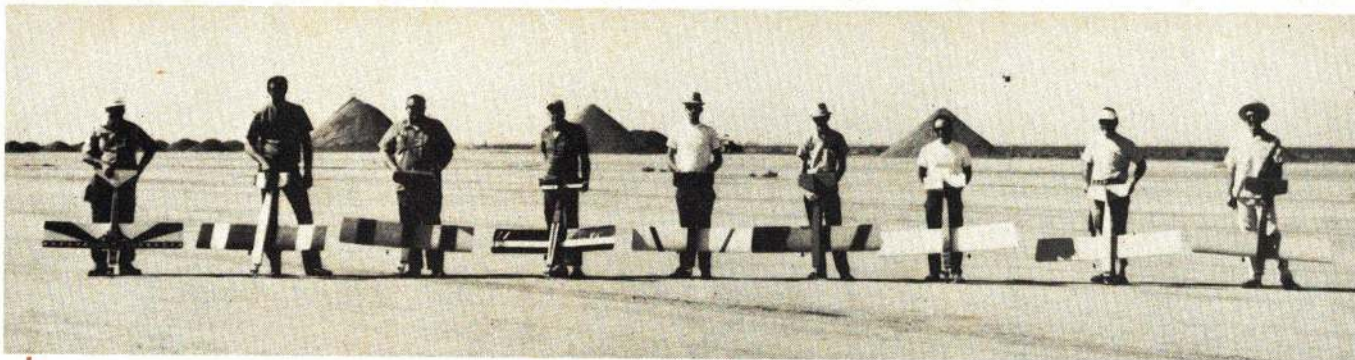

Quicky 500 is already a popular craft in Southern California clubs. It replaces some Open Pylon racing activity.

Ready to take off on sport flight holding is Denton Stockton with Ron Neff at the sticks.



been proven by the number of "Quickys" built by non-racing modelers who fly the ship in all types of club contests.

As a club racer, the little airplane has demonstrated it is just what the fellows wanted. It points well on the straightaway and has no tendency to snap roll in the corners.

Originally, any type "40" engine was allowed and racers being racers, rear intake engines, some modified by experts, were used. This lack of limitation on engines offset the advantage of a "one design class" so rules were changed, then changed again. Now our club rules require stock series "71" K&B front intake RC engines and 10% fuel is furnished at the races. With this setup, the models will fly around 100 mph on the straightaway and a good flier can turn the standard AMA Formula One course in close to two minutes. Clarence Neufeld installed one of his old Formula One engines with hot fuel in a "Quicky 500" and turned a 1:43. Not bad for a little square airplane. This was about as fast as he was turning with his Minnows at that time.

The "Quicky 500" has also proven its worth as a trainer for future Formula One pilots. Several of our local fliers have gone onto Formula One racing and what they learned by flying around pylons in club races has been a real asset. You can make a lot of mistakes and recover with a "Quicky," avoiding what would be instant trash with a heavier and faster Formula One racer.

Don't let the fact that the "Quicky 500" was designed for racing dissuade you from building one. It's a rugged, easy to fly model that can do most of the stunt patterns and with an ability to slow down for landings which will surprise you. No matter how slow you fly, the ailerons will show no tendency to reverse or quit working.

I can't say for sure how many "Quicky 500's" have been built. I quit counting after forty. You can be sure that the "Quicky" is a well-proven design, capable of giving many hours of pleasure whether it be club racing or just barnstorming around. I don't consider the "Quicky 500" a trainer, but anyone who has advanced to the aileron stage shouldn't have any problems with it. Give it a try, it's a fun airplane!

Construction

The construction is simple, but still requires some explanation. I prefer to start with the wing. Cut 18 ribs from

(Continued on page 67)



Thing!

HIGH PERFORMANCE ANGULAR RE-ENTRY VEHICLE OFFERS MUCH IMPROVEMENT ON BALLISTIC FLIGHT OF ORDINARY SHAPES. EVERY WORKSHOP SHOULD PRODUCE ONE FOR THE NEXT RAINY DAY.

BILL POTTER

This model originated from the scraps that remained after constructing a more complex aircraft. Unfortunately, both craft exhibited the same ballistic characteristics that only can be loosely termed flight. After several years of playing with Thing, as I affectionately call the creation, I have come to see several advantages in its design. The age-old modeler's complaint of warped wings has been cleverly eliminated by eliminating the wings. Because it is a glider, there is no messy fuel or cantankerous engines to fool with. Its small size allows storage in a desk drawer. Its peculiar performance ends the need for a dethermalizer.

Construction

If you find the three-view drawing confusing, it is because it is not a three-view. Only the shapes of the parts are shown, not their relationship. If the plans are used as three-views, great hardships will result.

First, cut off five 4" lengths of 1/32" balsa sheet. Edge-glue these to form a 4 by 15" sheet with the grain running width wise. Lay out the top and back on this sheet. Lay out two sides on the 1/16 sheet, using a razor blade and a straightedge (or, perhaps, a well-trained beaver) to cut out the pieces. Keep track of the bottom edge (appropriately labeled "bottom edge" on the drawing) of both sides.

Next, lay a bead of glue along the bottom edge of one side. (If you're some sort of strength fanatic, you may want to double glue all joints.) When the glue gets tacky, put the other side up against it, bottom-edge to bottom-edge. Raise one side (keeping the two edges in contact) to form an angle of about 110 degrees. At this point, the model should resemble the tail end of

(Continued on page 71)

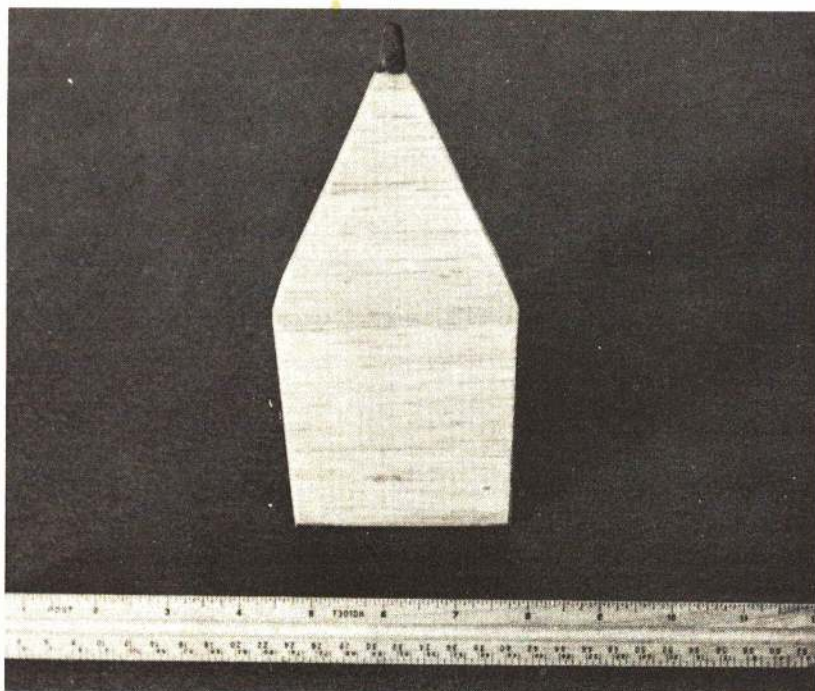

Top side is flat. A hook could be added near the nose for catapult launching to orbital velocity.

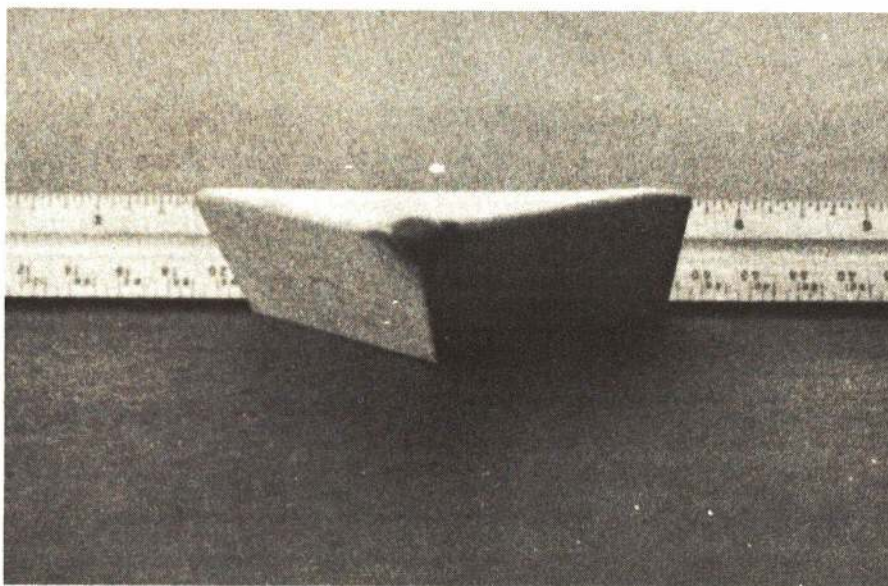

Above: Small size allows easy storage in desk drawer. This is the view seen by the on-coming air when Thing is in flight.

Below: This photo shows the bottom view.

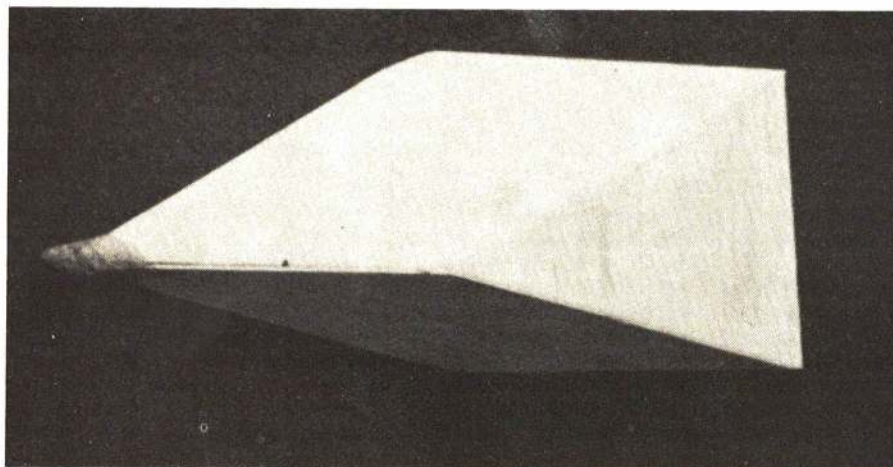

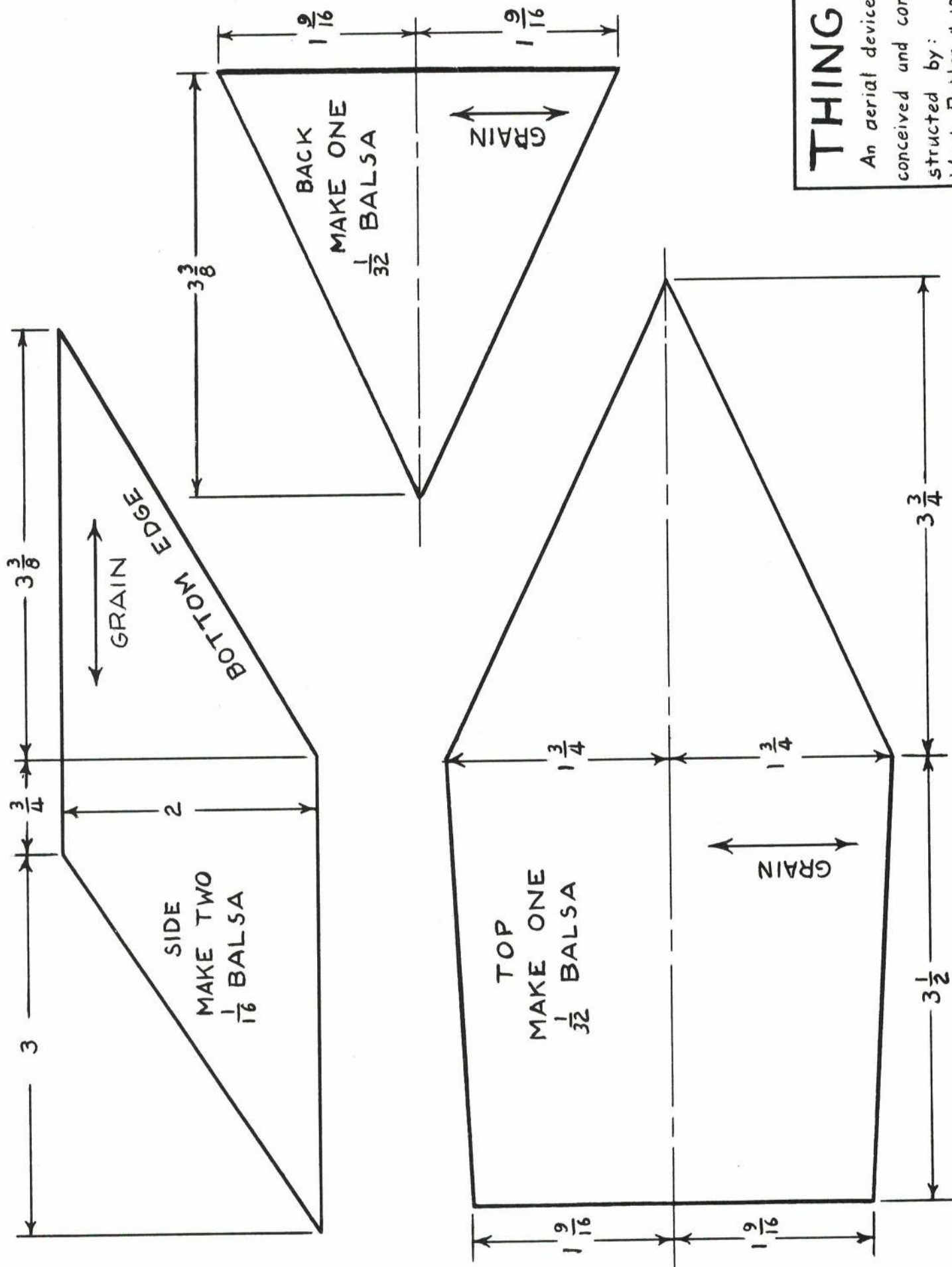

THING
 An aerial device
 conceived and constructed by:
 Wm. L. Potter 4-10-72

RC Helicopters at the Nats

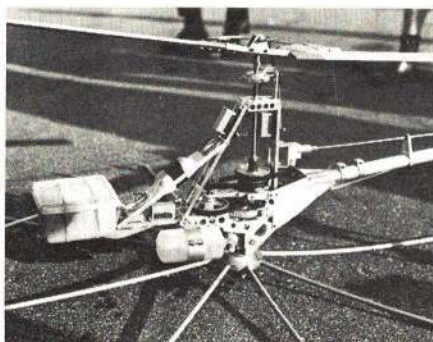

One can't help wondering why Ernie Huber keeps his lunch in the box up front. Balances best before the meal. Excellent design won best flight award.



Cranking up the workmanship award-winning model is Faye Peoples. Model based on 2-B from Burkam's WHA1 column.

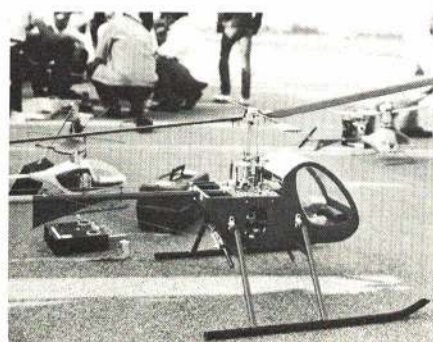

An O&R Compact engine with self-contained clutch, gears, and pull-cord starter powers Dave Gray's big model. Shows great possibilities, still being developed, perhaps a Du-Bro kit.

JOHN BURKAM

Fifteen helicopterites and 17 machines appeared for the first RC helicopter competition in the United States on July 27 and 28. Seven of the copters were the popular Du-Bros, one was a Du-Bro converted to shaft drive, one was a Schluter Hueycobra, one had Schluter mechanics and an original fuselage. The other seven were scratch-built, shaft-driven original designs. Most amazing was the fact that all of them were practical, flyable machines!

Ernie Huber stole the show by flying his original design, belt-driven machine all over the sky like a Pattern ship under perfect control. He started his Super-tigre 60 by pulling a piece of timing belt between a roller and his toothed flywheel. Then he twisted a knob on the tail which engaged the main rotor. Being more of an airplane than helicopter pilot, he wasted no time in hovering. He climbed out and up and began a series of right and left turns, dives and low passes that delighted the crowd and turned the rest of the beginning RC pilots green with envy. He made successful hovering landings after both flights and won first place in flying.

Faye Peoples, winner of the workmanship category, flew his original design based on the 2-B drive system (May 1972 AAM). On his second flight without tether lines, Faye hovered steadily at altitudes up to 20 feet, thanks in part to the teetering springs added to his Hiller rotor.

Ray Jaworski also added teetering springs to his Hiller type rotor, and it flew better than ever before. Ray, not so cautious as Faye, climbed his ship up to about 100 feet and started a left (downwind) turn. As speed increased,

more forward stick was required for forward flight. He made one turn which ended with a swoop to three feet altitude and another zoom to 30 feet. The next turn really ended with a nearly vertical dive. Latest word from Ray is that he has nearly completed repairs and is going to get that little bit of practice which will bring him the complete success for which he has worked so long and hard.

Gene Rock won first in design and second in flying with his SSP-4, an improved version of his altitude record-holder (August 1972 AAM). Gene "walked" his model up and down the runway with or against the wind, did climbs, turns, descents under full control, and picked up the wire hoop with his landing skid. After each of his two crashes—one due to a near miss with another model, another due to radio interference—the model was repaired and back in the air in less than half an hour, thanks to rugged, foldable blades.

Horace Hagen's Hueycobra performed impressively, though perhaps a little too close to the crowd. Unfortunately, a tail rotor pitch link slipped off during a hovering turn, causing him to lose power and directional control. Nevertheless, he had it repaired and back flying in about an hour. Horace won second place for his beautiful workmanship on the German kit.

Du-Bro helicopters *can* fly in a wind. All it takes is removal of the horizontal stabilizer. Bob Bentley, Dave Gray, Chuck Sherman, Bill Phillips and Mike Scun proved it. Dave Keats proved it so well that he placed third in flying. (He also picked up one of the hoops with his landing skid.)

Nate Rambo took the Schluter dynamic system and put it in his own original airframe. Nate hovered well, had a go at picking up the hoop (his helicopter didn't seem to understand his very expressive gestures), flew forward and backwards and other gentle maneuvers.

Dave Gray hovered his 14-lb. monster with the O&R gasoline engine, but hadn't yet advanced to the point of fast forward flight. Nevertheless, it won him second place for design.

Neatest trick of the meet was performed by Ed Sweeney, who had converted his Du-Bro helicopter to shaft drive, using a Veco 19 engine, mostly stock parts from race cars, nose gear fittings and ingenuity. His two-bladed rigid rotor had conventional airfoil type blades and was controlled and stabilized by a Hiller servo rotor whose cyclic pitch was controlled by the swashplate. By Saturday, Ed had licked most of the bugs in his design and managed to fly a full circle and make a landing with good control and good wind penetration. Think of the implications of this feat!

John Burkam brought his latest helicopter, Square 2-B, but it was not completed in time to fly.

General Observations: All of the helicopters which flew forward fast had Hiller type rotors, most of which strongly resembled Dieter Schluter's rotor. Five of the Hiller rotors had spring restraint about the teetering hinge and flew quite steadily. Rotors which had single bolt attachment of the blades survived roll-overs, even crashes. Those which didn't, shattered blades every time they contacted anything.

(Continued on page 80)

SEVENTEEN RC AND FOUR FF CHOPPERS PERFORMED AT THE 72 NATS ALWAYS DRAWING A LARGE AMAZED CROWD.

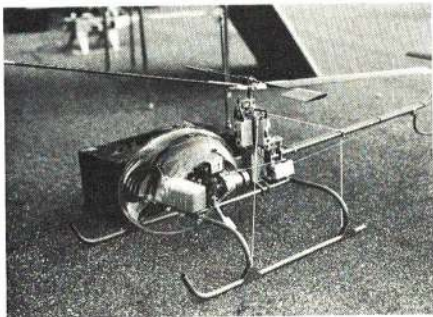

One of Ray Jaworski's two original design models. This one flew very well until it earned the "worst crash" award.



Horace Hagen and his much-flown Hueycobra from the Schluter kit. It is an inspiring sight and was the only scale design there. He makes flying look so easy.



Navy photo of another FF chopper flier, Tony Naccarato, Jr. It is 049-powered and a fairly simple configuration. Climbs very fast.

In free flight, Dr. Lee Taylor flew this familiar model. Separate blade sections provide cyclic and collective pitch control.

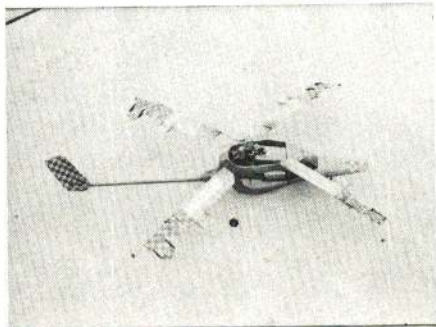

Dr. Taylor's model on its way up. Was second this year.



Very stock looking Du-Bro Whirlybird flown by Bob Bentley sports the much-recommended training gear. This gear almost prevents any turnovers.

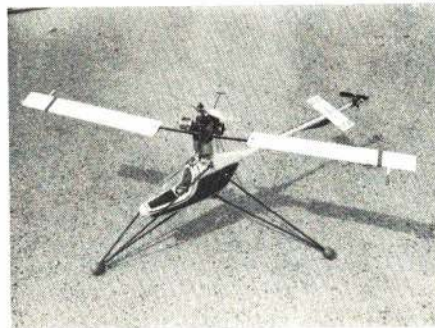

Ed Sweeney brought along a brand-new still-testing shaft driven conversion of the Du-Bro helicopter. Powered by only a 19 and uses many RC race car parts. Simple model will be published soon.



Still improving on his SSP model, Gene Rock made many excellent and smooth flights with this fourth version of the model just published in AAM. This model has torque rod driven tail rotor.

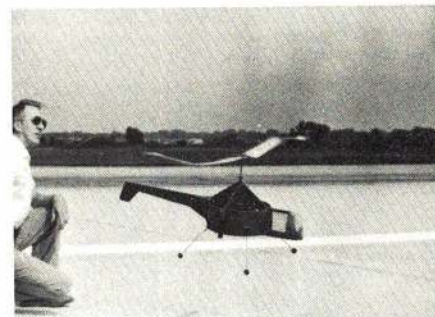

Glen Lee's large 15-powered FF model has low disc loading and so its sink rate in autorotation is very slow. Engine is on the main shaft for torque reaction drive but located below and inside the fuselage.

Nate Rambo starting his ship. It is made from many Schluter helicopter mechanical parts with Nate's own fuselage.



Dave Keats wonders which of all those Whirlybirds is his. Most of the models at the Nats were Du-Bros.

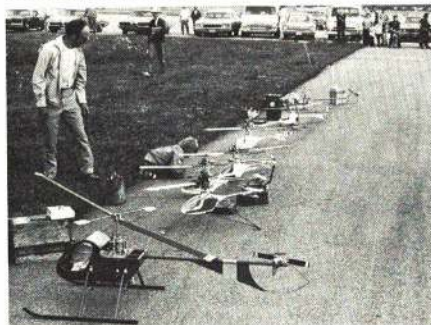

Third place in flying achieved by the always-airborne Dave Keats. He has become one of the master fliers of the Du-Bro Whirlybird.





Andy Zoph of Kankakee, Illinois, and the first 100 point spot landing of the 1972 Nats.



Dan Pruss introduces the winners of the Team event representing the Greater Detroit Soaring and Hiking Society. From left to right, Ray Vandierdonck, Otto Heithecker and Earl Pell.

Eight-year-old Yashiri Sato receives honorable custom presentation from CD Dan Pruss for Best Junior Achievement.



Grand Champion Ray Vandierdonck leaves no doubt how he feels about his success in being top dog of the '72 Nats.



Photos by John Harast

**133 CONTESTANTS
FROM ALL OVER THE U.S.
COMPETED FOR TOP HONORS
IN SPEED, DURATION,
PRECISION, AND SCALE.**

CARL MARONEY

Proud as punch to receive the top honor in Open Class Speed event flying a computer design ship is Hugh Stock of California.



Hard-working Neil Liptak stands guard over his four-sided scoreboard to post updates as tallies come in.



Gary Joseph of the North Riverside (Illinois) Checkerboard RC Club with his Marks Model "Windfree."



A lineup of Kestral 19s are all owned by Californian contestants.

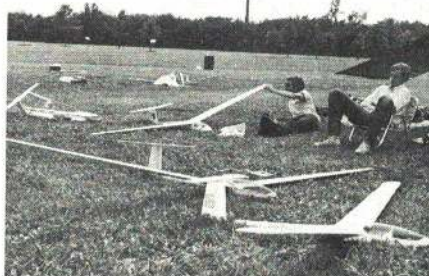

A record turnout of contestants converged on Checkerboard Field at the Miller Meadow Forest Preserve in Maywood, Illinois, just west of Chicago, to attend the Third Annual Soaring Nats. The Silent Order of Aeromodeling by Radio Club (S.O.A.R.) has hosted this glider activity three consecutive years for the enjoyment of all soaring enthusiasts in the hopes of getting the Academy of Model Aeronautics to recognize Soaring as an official National event. There is serious doubt that another National Model Airplane Meet will take place without full AMA support!

The Checkerboard Field was a natural for the Soaring Nats since this parcel of land was once the Chicago Airport composed of cinder landing strips existing from 1918 to 1927. In 1921 a young barnstormer, Dave Behncke, purchased the land and gave plane rides and lessons, and hauled freight. The field name originated from Behncke's plane, Jenny, painted black and white.

We arrived at the contest site about 5:30 a.m. Sunday morning to put a bit of polish on our flying skills. However, we received quite a surprise: The park entrance was chained. With daylight just breaking, we could see beyond the encompassing grove of trees and picnic tables to a fantastic large site to stretch a towline in a 1000 ft. radius. Wow,

RC SOARING NATS CHICAGO, ILL.

July 23-24

1972

Sponsored by
S.O.A.R.

right there in suburbia! As the morning sun rose, workers arrived, gates were unlocked, contestants flocked in, wings and fuselages met and ships gleamed in the reflecting rays of the sun—we were ready to commence with the beginning of the largest gathering of the nation's soaring fraternity.

Very little time was lost in laying out site and the contestants' area filled with multi-color canopies for protection from the hot day ahead. As the registration tent was set up, the entry line grew and appeared to be endless. By 10:30 a.m. there were over a hundred entries registered, and the final tally was 133 contestants. Shortly afterwards, CD Dan Pruss conducted the opening ceremony with a welcoming speech and then a pilot's briefing to review the day's events. A moment of silence was maintained to honor the passing of Howard McEntee earlier this year.

One interesting feature was implemented at this Nats, the standardization of launching devices. Credit for this effort goes to S.O.A.R. members Neil Liptak and Dan Pruss for designing and building four electric winches which provided equal performance.

Observing the frequency board, contestants knew they were in for a long wait with heavy frequency population

having 21 entries on 75.64 MHz and 12 each in 72.08, 72.24 and 72.40. Robert Williams, flying a Cumulus, was the first contestant to test the green air at 11:16 a.m. to start the first event for three-min. Precision Flight. Pilots' skills were tested as weather conditions changed during the afternoon with increased wind speeds of seven to ten mph. Like a bee's nest the three-min. time limit for the Precision event kept a constant humming of winches, a sky full of birds, and high excitement at the runway as gliders were following each other in to get either 0, 50, or 100 points for landing.

In the late afternoon, contestants competed in the ten-min. Duration event at a much slower pace and only half the event was completed before dusk set in. Something new, especially for the eastern fliers, was the Scale Sailplane competition in which entries were judged in fidelity and flight. This category had seven entries with mostly California participation. The West Coast contingents naturally had the edge on the Speed and Precision events, since the AMA provisional rules being used were proposed by the League of Silent Flight and are the substance of western contests. This diversified round robin of events (Precision, Duration and Speed)

demonstrates a pilot's overall capability to perform and separates skill from luck.

It was clearly evident that the Californians had the expertise in runway landings, demonstrating accuracy time after time. The technique was hot, fast and hard. This was by no means showmanship as geographical conditions on the West Coast offer much slope soaring activity which influences the pilot's method of landing approach. The contrary applies in both the Midwestern and Eastern states which have mostly thermal conditions for flying. Windy City was ideal during the contest, holding up to her name.

The array of original new designs which cropped up was unbelievable. A majority of them had fiberglass fuselages with built-up wings covered in MonoKote. Mr. Topflite, better known as Sid Axelrod, had a prototype of their plans for a kit. The fuselage, made from three crossed layers of balsa sheet molded into fuselage shape, is extremely light. Most likely the 1973 Toledo show will officially host its debut. Some of these new creations will tell their story in the model magazines, while others will get mass produced as commercial

(Continued on page 72)

A Magnificent Flying Machine for .60 engines

Lancer

SL-62

\$39.95



KIT FS-30 SPAN 62" LENGTH 50" AREA 700 SQ. IN. FLYING WGT. 6¼ LB. ENGINE .60

A Contest-Caliber Sport Flyer

The Magnificent SL-62 is the result of 2 years' design and testing to meet the "if they had only made it this way" suggestions directly from the R/C Flyers in the Field. The result is this 62" Span beauty which has fulfilled expectations and aroused great enthusiasm with the R/C Flyers who have seen and flown the test models. Collective engineering-design is reflected in the fast and easy way the SL-62 goes together, and the flying . . . well, you've just got to take the Stick to believe it; it's that good.

Finest Quality materials include Prime Grade, Density-Selected Balsa sanded to micrometer tolerance. Imported Birch Plywood, etc. Fuselage features Die-Cut one-piece full-length sides, Plywood doublers (that go past wing for maximum strength), five Bulkheads—accurately Die-cut; combined with shaped Nose and Cowl blocks, quickly

go together to make a sleek strong fuselage; Topped off by a jet-shaped Canopy. Rugged custom made Aluminum Engine Mounts make engine installation a pleasure and formed music wire Tricycle gear includes fully-sprung stress relieved Nose gear.

Unique table-top construction insures a warp-free wing, a must for top performance. Wing parts are Die-cut, shaped, etc., to insure fast accurate assembly; and Balsa Sheet covering keeps warps out, resulting in a light rugged wing. Tapered strip Ailerons provided, are simple to install using the new ready-to-use simplified Aileron linkage units. Wing assembles to fuselage with nylon screws in hardwood nut-block provided, in the unusually complete Hardware pack which includes all the special nylon R/C fittings required. Rudder and fin are sheet, Stab is built up and sheet covered to keep it permanently flat.

STERLING MODELS • BELFIELD AVE. and WISTER ST. • PHILA., PA. 19144

If no dealer available, direct orders accepted—with 10% additional charge for handling and shipping. (60c minimum in U.S., \$1.25 minimum outside U.S.)

- Catalog of entire line of airplane control line model kits, R/C scale and Trainer kits, boat model kits, accessories; etc. 25c enclosed.
- "Secrets of Model Airplane Building." Including design, construction, covering, finishing, flying, adjusting, control systems, etc. 25c enclosed.
- "Secrets of Control Line and Carrier Flying." Including preflight, soloing, stunting, Carrier rules and regulations, Carrier flying hints and control line installation instructions. 25c enclosed. No checks. Only U.S. money orders or currency accepted.

Name _____

Address _____ City _____ State _____ Zip _____

Sterling
MODELS
INC.
PHILA., PA. 19144, USA

Take a Good Look at These.....

Fabulously-Authentic Super-Detailed

"Stick Model" Kits

THEY'RE FAMOUS

Piper Cub Super Cruiser is a classic 3-passenger light plane of the forties, and an old time modeler's favorite.

- Citabria made by Bellanca — a real aviation pioneer, is the sleek, powerful, modern light plane, a familiar sight at many airports
- Curtis P-40 Warhawk. Work horse of World War II, made immortal by the Flying Tigers in China and Burma.

THEY'RE UNIQUE

Because such amazing detail scale authenticity is achieved with kits that are relatively easy to build. Plans include 3 views of full size Aircraft and show how to install movable controls from cockpit. Authentic color scheme shows on full color kit box lid.

THEY'RE VERSATILE

Kits can be built 6 different ways: Rubber powered, as supplied, then using O20, O49 or CO₂ for power: Free Flight, Control Line, R/C (with pulse or single channel) for static scale. Any way makes a museum-like model.

THEY'RE EASY TO BUILD

Just about every frame member is accurately Die-cut from the finest quality Balsa Wood, sanded to micrometer tolerances . . . and every part is numbered to insure fast and accurate assembly as shown on easy step-by-step plans.

THEY'RE COMPLETE *

Highly detailed plastic parts included, simplify the assembly and add a genuine touch of realism-in-miniature. Covering material, pre-formed wire parts, wheels, authentic decals, hardware pack that includes control system parts; is a partial list of the contents of these fine quality kits.

* Dry Kit. Rubber power material supplied.
Other power and equipment not included.

THEY'RE AT YOUR DEALER

GET OVER AND SEE THEM NOW . . . BUY ALL THREE



SPAN 35½"
SCALE 1"=1'.0"

**KIT E-6 PIPER CUB
SUPER CRUISER 7.95**
12 Pack — 15 lbs.



SPAN 33½"
SCALE 1"=1'.0"

KIT E-5 CITABRIA 7.95
12 Pack — 15 lbs.



SPAN 27"
SCALE ¾"=1'.0"

KIT E-4 P-40 WARHAWK 7.95
12 Pack — 16 lbs.

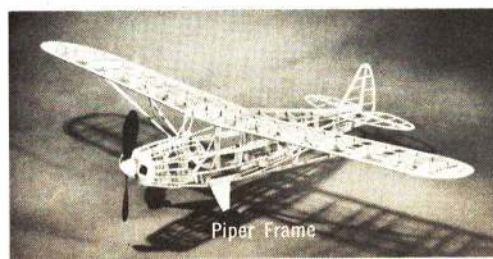

Piper Frame

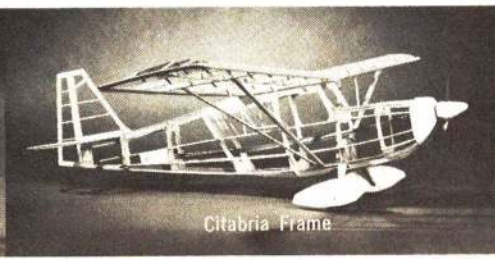

Citabria Frame

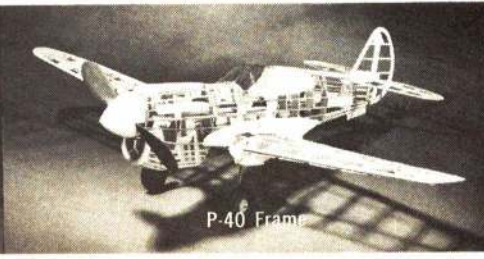

P-40 Frame

FUN PLANE FOR OWNERS OF SMALL, SPORTY CARS
AND LIGHT, FOUR-CHANNEL RADIOS. MODIFIED HEADMASTER MAKES
IT LIVELY—BUT FORGIVING

NORBERT DEMBINSKY

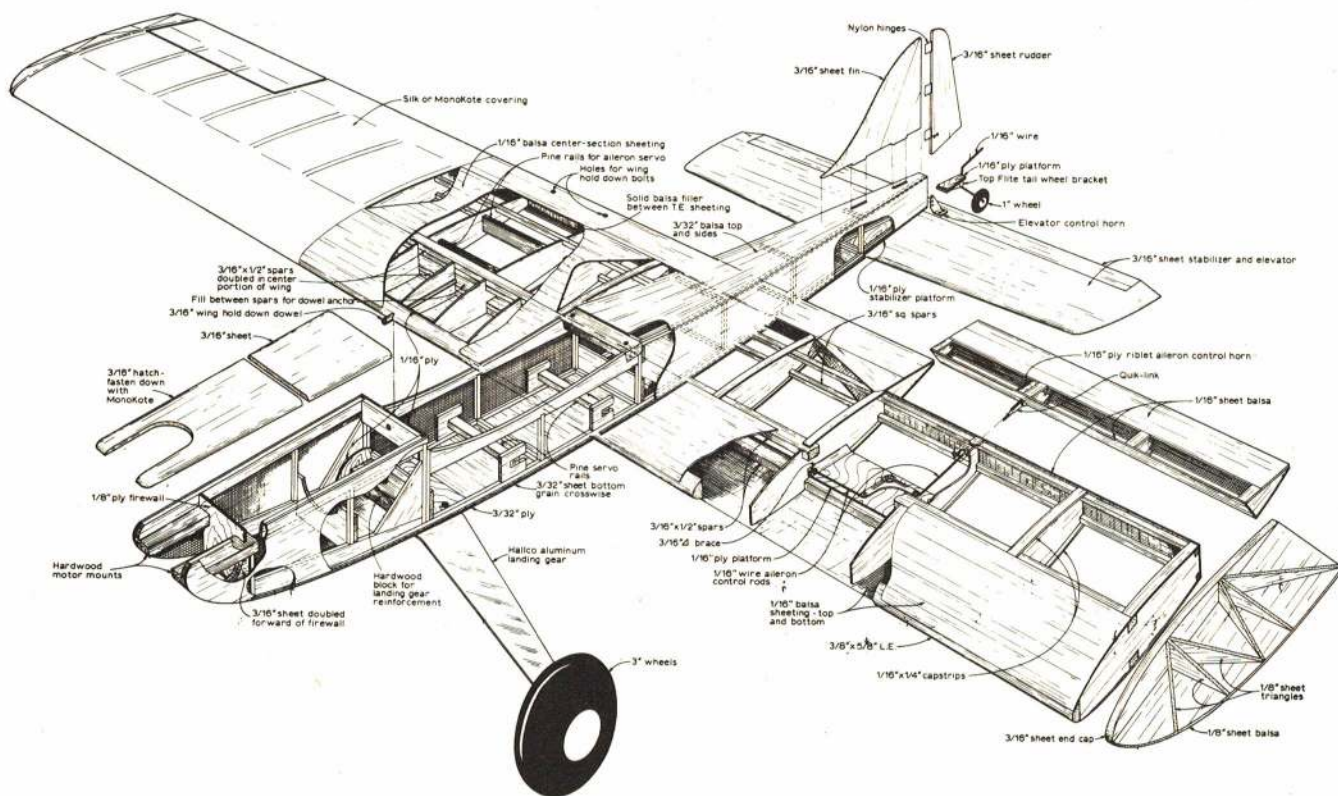

Snoopy

The models presented in past magazine articles tend to favor the contest type airplane. The medium size weekend or sport type airplane has been somewhat forgotten. The Snoopy Trainer was designed to fill the gap for the guys who like to fly the medium size airplane for sport or relaxation on the weekends.

The Snoopy Trainer can be placed in the luggage compartment of automobiles without removing the wing which eliminates carrying extra pieces to and from the field. This design takes advantage of the small, lightweight radio sets—the frontal area of the fuselage is low in order to compensate for the thick airfoil section which is needed for smooth and forgiving characteristics. A semi-symmetrical airfoil section is used for better wind penetration, inverted flight and easier handling. The ailerons have been added for lateral stability and increase control due to the absence of dihedral in the wing. The standard two

(Continued on page 64)

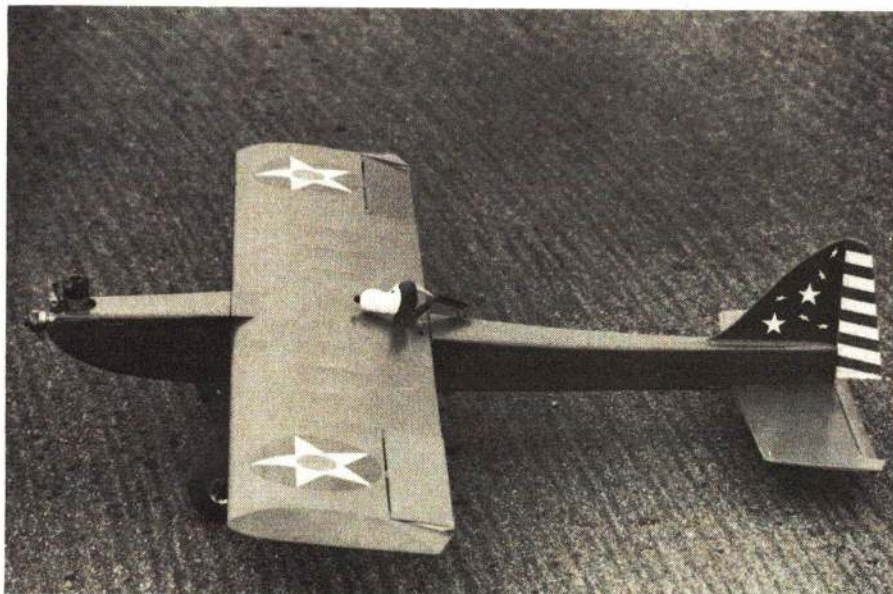

No dihedral, inset ailerons, thick semi-symmetrical wing give Snoopy fine Sunday stuntability.

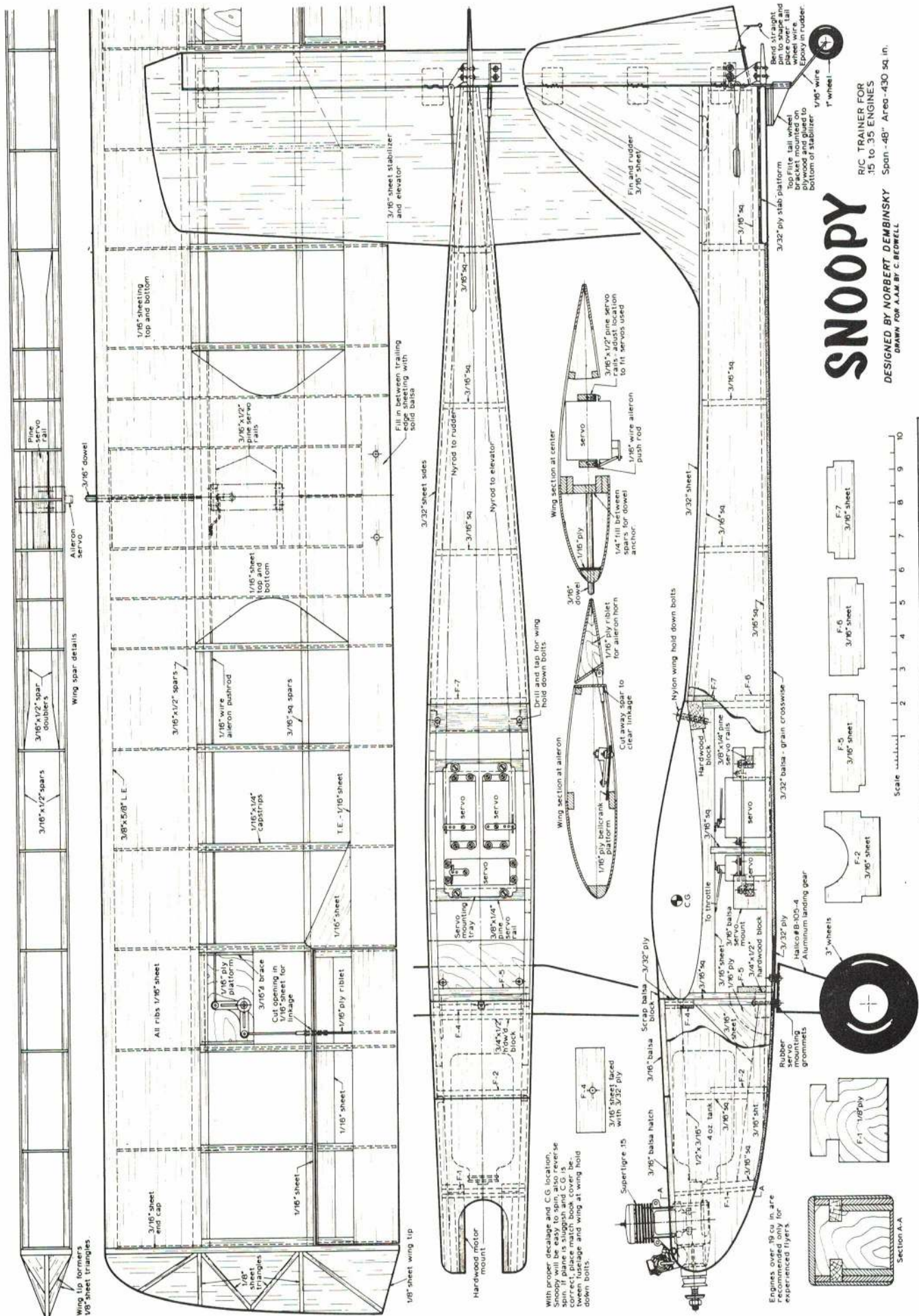

SNOOPY

R/C TRAINER FOR
 .15 TO .35 ENGINES
 DESIGNED BY NORBERT DEMBINSKY
 SPAN - 48" Area - 430 sq. in.
 DRAWN FOR A.A.M. BY C. BEWELL



FULL SIZE PLANS AVAILABLE - SEE PAGE 84

With proper decalage and C.G. location, Snoopy will be easy to spin, also reverse spin. The motor should be mounted on a special place match book cover between fuselage and wing at wing hold down bolts.

Engines over .19 cu. in. are for experienced flyers.

Section A-A

Where the Action is

Control Line

**BILL BOSS
SPORT AND SCALE**

Twin Engine Tuning: Many Scale modelers flying twin-engine craft worry about getting the engine rpm set to create a torque effect for increased line tightness. This is usually accomplished by leaning out the left engine to



Raymond Leone contends that a diesel is the best sport flyer's engine. Don't overlook the many small dependable foreign-made diesels available. They are not expensive, are powerful, and easy to use.

Tuning engines of multi-engined scale models for line pull and reliability can be done easily with a little trick, see text.



near maximum rpm while the right engine is run at a somewhat lower rpm or richer needle valve setting. However, this procedure can create an additional problem: When the engines are idled down for landing speed or taxiing, the right engine gets loaded with fuel and quits.

Orin Humphries tells us that a recent experience of his with a multi-engine plane indicates that another engine adjusting procedure might be used. While flying a Royal Kit P-38 powered by two 45s in a fairly stiff wind, the plane's left engine quit with no apparent effect on the line tightness. The plane had no unusual rudder or engine offset. Perhaps the procedure of making one engine richer than the other is not necessary.

Based on his new findings, Orin decided to experiment. He found that he got excellent flying results using two different pitched props and leaning out both engines for their most efficient rpm. He used a 10-6 on the left engine and a 10-3 1/2 on the right. The different props not only permitted both engines to be leaned out for maximum rpm, solving the problem of one engine loading up during low speed operation, but provided the added insurance of line tightness with the torque effect created by different size props. If you are a twin-engine plane modeler, this procedure might be what you are looking for.

Two Extremes: As we all know, the problem of obtaining model airplane flying sites can be a real chore, and such was the case for the Association of Model Airplane Clubs of Greater N.Y. Some 12 years ago the group embarked on a program to obtain at least one CL site in each of the five boroughs of New York City. After six years of negotiations with city officials, sites were provided in all the boroughs except Staten Island. It was another six years before the Staten Island site was dedicated on June 4, 1972.

The other extreme is reported by Patrick Potega who tells of a three-circle site donated, apparently with little, if any, effort by local modelers, by the Madison, Wisconsin Parks Commission which remains unused. In an attempt to organize local modelers and put the field to good use, a select group of modelers thought a large contest might be the answer. Since Model Aviation can be a saleable commodity, the modelers asked the management of the East Towne Shopping Mall to sponsor a contest. Not only did the shopping center sponsor an AAA meet, they provided much of the manpower to run the event. The contest was called the First Annual East Towne Mall Contest and was used to kick off a week-long sales promotion for the shopping center. It is hoped that this activity will bring out the Madison modelers to show them the benefits of being organized. Hopefully a club will follow.

It appears that one thing stands out in both cases: Model Aviation can be sold. It's just a question of the right approach, a little time and, in most cases, plenty of patience.

Try a Diesel: If you do a lot of sport flying, you might want to consider using a diesel engine. Raymond Leone suggests they are the ultimate for sport flying since there are no glow plug burn-out problems and there is no battery to carry. He is presently flying a

modified Junior Flite Streak powered with a P.A.W. 19-BR Diesel, swinging an 8/6 nylon prop; he is getting satisfactory engine performance without the use of a fuel ignitor. For those of you who might like to try the diesel route, Ray suggests the following fuel: 30% Pennxoil Aircraft SAE No. 70 mineral oil, 35% Merk Motor priming ether (most drug stores carry it in 20 oz. cans for \$2), and 35% kerosene.

JOHN SMITH SPEED AND RACING

Thanks a Million: Thanks go to all contestants who flew Speed at the '72 Nats. Thanks to those who understood the problems of running the meet without Navy help, and thanks to those who volunteered their services to help time, pull-test, and other duties where they were needed. I believe, at least in CL events, we proved we can do the job on our own. On Saturday afternoon when all the flying was done, the entire gang left our area cleaner than when we arrived. I really appreciated your efforts.

Danny Bartley Award: A new award this year was given in memory of Danny Bartley, past CL champion who was killed in an auto crash early this year. The award, a joint effort of all speed fliers headed by Bernie Stadium, is a beautiful silver and walnut trophy to be given each year, along with smaller permanent silver and marble awards, to the top CL flier at the Nats. This year's winner was Glen Lee who is a fine example of everything Danny believed in. Glen, a past member of the FAI CL Speed team and a contest flier for many years, was awarded the trophy at the Model Airshow on Sunday. Many of Danny's friends were there to see Glen accept the award. Congratulations, Glen.

RCer Wins A Speed at Nats: Luke Roy, who defected to the ranks of button pusher and stick twidder after winning a place in the FAI Pylon finals (RC), and his partner Gary Korpi put together a winning A Speed flight to take all the marbles in Open A Speed. Luke, one of the best engine men around, had his troubles on B day when, after launching his piped speedster, the setting went sour while he was still in the dolly. The model slowed down and finally fell out of the dolly, backwards! It should be noted that he and Gary did win FAI Pylon (RC) on Friday. Good to have you back Luke.

More on the Nats: More Junior fliers than ever showed up this year, many in 1/2A Profile Proto. Jet entries were up, too, with a total of 34 entries processed. Many home-built Jet heads were around, with most running very well. C entries totaled 43 to 44, way up over last year. Glen Lee took C, running his LEE-OOPS OPS .65. Rat Race was taken by Bill Keller, of Dayton, Ohio, running an HP. He said he was running 150 to 155 mph in traffic! Bill also put together the winning KB 40, 71 series, which won Senior.

No Tin Ear Award This Year: This special award was not made this year due to the terrible weather, but it had everybody guessing until about Thursday. There just wasn't room on the trophy for all the names. Next year we'll have to have one for each day.

JOHN BLUM CARRIER AND STUNT

Which Way Profile: Another editorial concerning the future? Yes! Much is printed about the encouragement of the younger and beginner modeler. For every high-level competition event there is a low-keyed, economical event aimed at being easy-to-enter and fun. Judging from magazine and club newsletters, there is a need for this. We'll cite Beginners Stunt, 1/2A Goodyear, A-Class Rat Race, etc. After all, what is a hobby, but fun?

Many of the present full competition events started this way: Rat Race, Combat (Slow Combat was first), Goodyear, 1/2A Proto and, of course, Profile Carrier. The



Fox 40 powers this quite real-looking P-39 stunter by Lew Wolard. Unique use of muffler pressure to tank for smooth runs.

philosophy which propagates these events leads all to believe, and rightly so, that they will serve as stepping stones to the more classical events. But what happens? Soon certain small infractions of the rules, and the rule book is filled with event rules originally intended for low-key events, are apparent. The competitors specialize, the more advanced create what they can't buy to present an edge over the other competitors, new specialized equipment is created, and Puff the Magic Dragon is again in view. In Heat-Racing alone, it has gone from Team Race to Rat Race to Profile Race to Goodyear to Mouse Race.

Is Profile Carrier approaching the early stages of extreme refinement? The event is well into the final stages with refined aircraft, reworked engines, reworked and refined engine accessories, etc. Equipment is and will be on the market to further refine the event, and at the same time, raise the cost and eliminate many modelers from this low-key competition.

As with any point of view, some modelers are "against," some are "for," and many could "care less." What is the next step for



Profile Carrier, where is this event going? Is it still the beginner's event as intended?

Novel-looking wing tips are scale to the real Seagull XSOC3-1 modeled by Noal Hess. An efficient and attractive Carrier job.



Profile Carrier? It's history repeating itself!

Line Length Difference: All official events specify some sort of tolerances on line length. Where speed affects the ultimate score or placing, all contestants' lines must be within the specified range. In Stunt, the tolerance is liberal, but speed is not part of the score. In Navy Carrier, the rules specify 60 ft., plus six in., minus zero. The range is then from 60 ft. to 60½ ft. However, this is measured from the center of grip (or handle) to the center of the model. Consequently, the wingspan of your Carrier model affects the ultimate length of your control lines. If you buy a set of 60-ft. control lines and then hook them to the model, you may find the officially measured length is over 61 ft. If your model has a span of 30 in., your lines, and the leadouts must be considered, range from 58'9" to 59'3". If you have more than one Carrier model and the wingspans vary, work out a range which will adapt to one set of lines or you may find a larger model places the center-to-center measurement over the maximum.

Handy Canopy: Fred Smith of Hutchinson, Kansas offers the idea of using 1/8" thick plexiglass for canopies on profile models. He backs up plexiglass with wood block for cutting, allows 1/8" extra in height to be mounted in a groove in the fuselage and, after drying, adds a fillet of epoxy at the base of the canopy. Tinted plexiglass enhances the model's looks.

HOWARD RUSH COMBAT

Who Needs a 36?: Dan Jones has been competing in 35-size Combat contests with his 15-powered Splinter, and winning. Amazing, but it's happened before. Don Green of Kansas City won a big meet ten years ago with a Max 15 on a scaled down Voodoo.

How can the 15s compete? The smaller engines are more highly developed because of competition in the FAI Speed, FF, and TR events. So power/weight ratio is higher, making possible a small, low-drag airplane with a wing loading light enough to enable tighter turning than a 35 plane. Of course, drag from lines and streamer takes a greater proportion of the 15's power. Typically, a 15 plane in a match is slower and turns better than a 35 plane, putting the smaller plane in the same category as John Carr's Guillotine which has been quite successful in competition.

Loop Sizes: By my calculations (available upon request), a Combat model with a wing loading of .053 oz./sq. in. (equivalent to a 16 oz. Tyrantula or 18 oz. Nemesis) would need a lift coefficient of 2.64 to turn the five-ft. radius loop some folks claim for their planes. This is unrealistic; the best one could hope for is about 1.1 without flaps or 1.8 with flaps, corresponding to tightest possible loop radii of 12 ft. and 7.3 ft. A plane turning a 12-ft. radius loop at 100 mph is pulling 56 Gs, which ain't bad. Stunt planes have heavier wing loadings than Combat models and, as Bill Netzeband has pointed out, can come



Dinosaur Combat Team of Baltimore, all juniors and seniors design their own planes and beat the big guys! L to R: Tony Viassis, David Bush, Phil Bush, and Walter Siedlecki.

nowhere near the five-ft. radius corner specified in the AMA Pattern.

Tallyho, a New Fox: The hot shot Combat competitor may overlook a \$15, plain-looking engine, but the new Fox 36 deserves the attention of both sport and contest fliers. With Fox 40-40 fuel and a Rev-Up 8-8 prop, my 36 pulls a Nemesis II at 105 mph. Pretty quick, but what's extraordinary about the Fox 36 is that it weighs only seven oz. It makes possible a plane as small as 280 sq. in. with the same radius turn as a 339 sq. in. Nemesis powered by an 8½ oz. Supertigre. Reduced drag on the smaller plane will let it roll at very competitive speeds.

The absence of fancy bearings makes the Fox 36 legal for most Slow Combat meets and contributes to its light weight. Other factors in keeping it light are a shorter-than-usual crankshaft, which runs in a bronze bushing, and a very thin sleeve. Replacing the huge steel prop washers with aluminum washers sized for 8-8 props could cut another half oz. or so from engine weight.

The crankcase is a new design and appears to be made specifically for the 36. Fox's traditional DeSaxe offset cylinder arrangement is abandoned in favor of a design in which the cylinder and crankshaft centerlines lie on the same plane. The case is stiffened on three sides by external ribs. The intake is round, presumably because the bushing has to be drilled after installation in the case, so hopper-uppers can spend many happy hours with little files making the hole in the bushing square. The inside diameter of the lower crankcase is smaller than that of the 36X, so crankcase compression is increased, which may be why the new case design provides a steadier run through tight maneuvers.

A word of caution from Duke Fox himself: The shaft bushing requires more oil than a ball bearing, so fuel for the 36 should contain at least 20% oil.

Oops: Speed claim for the Nemesis II (August 1972 AAM) was 133 mph, not 113 mph as printed. See? Not even the Editor believed it.

Free Flight

BOB MEUSER SPORT

Dixielander: Eighteen-years-old, and stronger than ever as a potent competition machine, the Dixielander, by virtue of its ability to handle lots of power in a small aircraft, is especially well suited to the new AMA short-engine-run rules. Full-size plans for the latest version of the Dixie are now available exclusively in the U.S. from the NFFS Services and Supplies, P.O. Box 322, Dallas, Oregon

97338, for \$2 each plus 50 cents for third-class mailing per order, or \$1.50 for first class. If you would rather draw than build, scale up the three-view.

A kit for the Dixie has been manufactured for ten years by A.A. Hales Ltd. of England.

Anyone know of a source in the U.S.? George Fuller's latest version, shown in the three-view, differs only slightly from the kit. Wing, stab and warps are identical. The wing sits a little further forward on the latest version, the fin is swept back—esthetically superior to the

old vertical-leading-edge fin—and the base of the pylon is a bit wider. An auto-rudder supplies the glide turn, replacing stab tilt. The kit could be easily modified. Other versions of the Dixie have taken their share of trophies: The E-Type, a "stretched" version (3½ in. longer tail moment arm, eight in. greater span, 29 engine); and a 60-engine version.

One of the criteria for selection of NFFS Model of the Year winners is the degree to which a model has influenced others, its impact on the sport. Look around: Chenault's Mini-Pearl, Schmidt's SHOCer, Linstrum's Limey, Hutchinson's Maverick, Zingo, etc. Of course it could be a coincidence! Another criterion is the model track record. In England alone Dixie has won at least 45 firsts, 14 seconds, and 20 thirds in major competitions including six firsts in the British Nats. In addition it has won the U.S. Nats at least once and, recently, the New Zealand Nats. We'll probably be seeing the Dixielander on the winners lists for some time to come, and I ain't just whistling Dixie!

nffs

NATIONAL FREE FLIGHT SOCIETY
Model of the Year

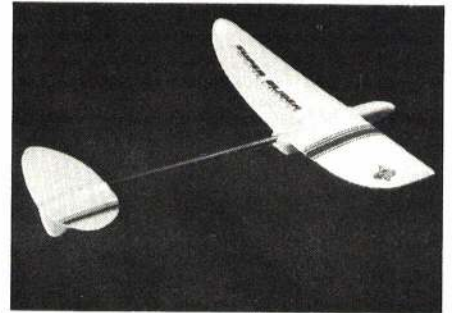
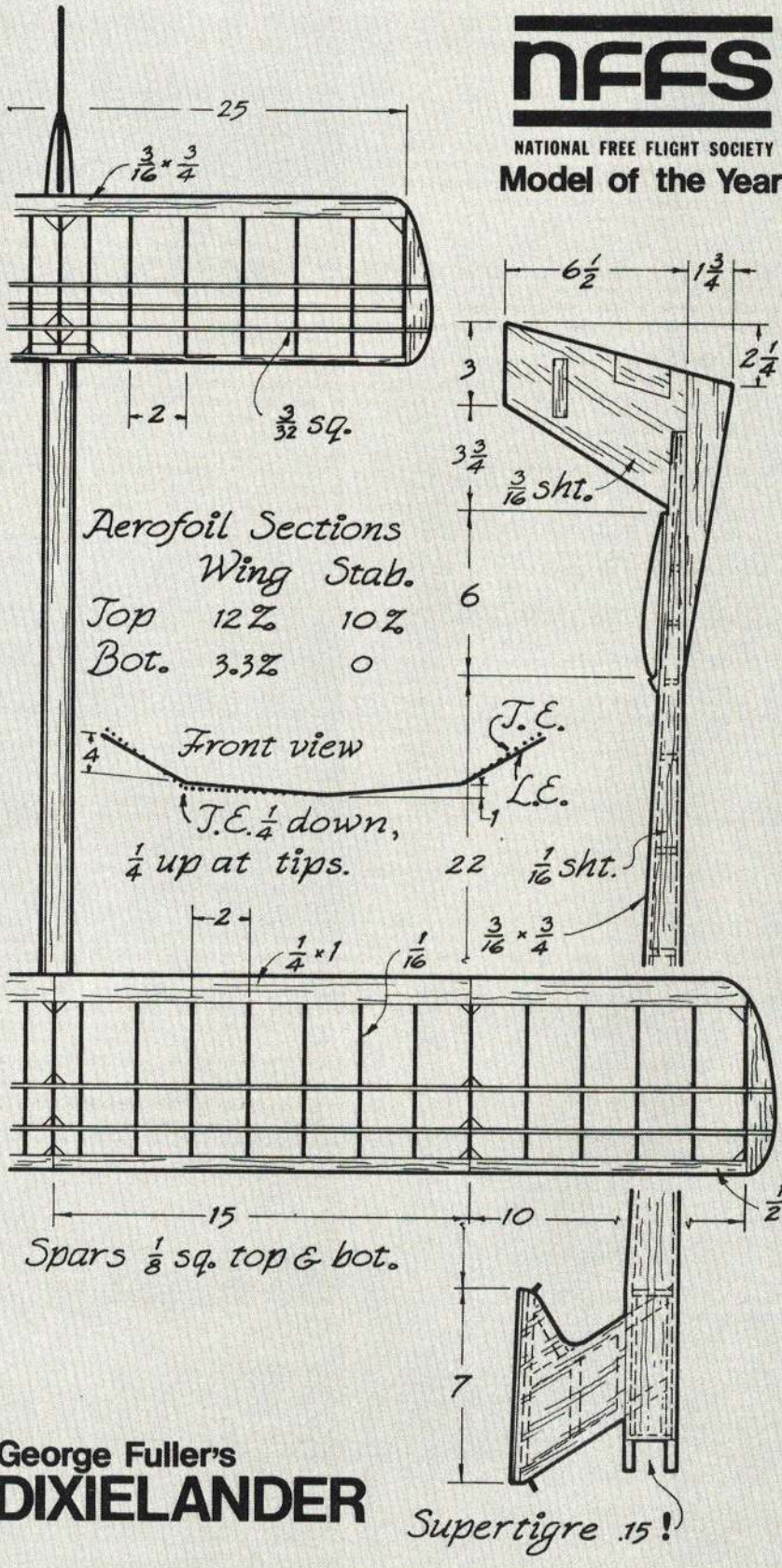

Super Slider is a super glider and comes ready to fly for only \$1.50. See text.

Superglider: It isn't often that the toy industry and the hobby-sport of model aviation meet on common ground, and certainly we want to dispel the toy image which pops into the head of John Q. Public at the mention of model airplanes. But it is difficult to ignore a genuine competition-quality hand-launch glider perched in the window of the local toy shop in all its ready-to-fly glory with a price tag under \$1.50. Then you open the instructions and find all sorts of good stuff about adjustments and thermals! Of course you can't use it in competition because of the builder-of-the-model rule, but it has other uses: Keeping your arm in shape and your thermal-sensing ability in tune without risk to your competition machinery, a means of introducing a friend to the thrills of free flight, a pacifier for kid brother who insists on eating your Sweeppettes. (Expanded polystyrene is non-toxic but, if eaten, might induce constipation—and it serves him right!) If your local toy emporium feigns ignorance of the Super Glider, induce them to have their distributor get a batch from NDC, 1609 So. Central, Kent, Wash. 98031.

Support Your Local Model Railroad Shop: These shops carry straight grained, accurately sized basswood strips as small as 1/32 square. Other useful sizes are 1/32 x 1/16, 1/32 x 1/8, 1/16 square. Bob White (U.S. Wakefield Team, 1971 and 1973) uses the 1/32 square for turbulators on his wings and props. Hand-launch glider builders sometimes use music wire, nylon monofilament, or bamboo to reinforce the otherwise tender leading edges of their wings, but most would find 1/16 square basswood superior—easier to handle, larger gluing surface. The 1/32 x 1/16 is ideal for HLG trailing edges, provides needed reinforcement and, because it is much harder than balsa, makes it easy to sand the trailing edge down to a uniform 1/32-in. thickness without danger of oversanding. Useful for outlining the entire tail is the 1/32 square if one is willing to forego elliptical tips. The useful life of a balsa prop will be greatly extended by a strip on the leading edge, and it is flexible enough to bend around the tip if the radius isn't too small. Titebond, slightly diluted with water, works fine, aided by strips of masking tape to hold the strip until the glue sets.

Other shapes of basswood—Ts, angles, channels, I-beams—are also available. Scale

modelers would do well to check out their enamels too. The pigments are very finely ground so a single thin coat will cover.

BUD TENNY INDOOR

Help a Beginner: From time to time, this column has offered hints for Indoor beginners. However, the most effective beginner help is from someone nearby, so why not foster a beginner group? Any modeler can help beginners, even while he is learning Indoor himself. Model clubs can be especially effective in such efforts by virtue of having meeting facilities and people to teach beginner classes. Also, a club can be invaluable in locating and getting permission to use flying sites.

Where to Start: Any club which has no Indoor experience can start with HLG and a beginner model such as an AMA Cub. After one session with standard Cubs, everyone can benefit by learning to lighten the models for better duration, smaller wood strips, condenser paper covering, wood props, etc. Introduce winders and rubber lube for increased duration. Finally, graduate to Pennyplane or Easy B to allow room for advancement.

Competition Classes: One of the most important types of competition for all beginners is a flight category especially for novices. The Tulsa Glue Dobbers had a very successful indoor season using separate events for Novice and Expert. This club had experienced Indoor fliers with spirited competition among themselves, but the real story was the extremely hot competition among RC and CL fliers in the Club who flew in the Novice classes.

New Events No Answer: Several existing events were originally designed especially for beginners, but all these events have been failures for that purpose. The reason is that the events were opened to all fliers, and beginners were lost in the shuffle as the experts dominated the event. Indoor Paper Stick and Easy B were intended as simplified model classes especially for beginners but, without restricting entry to beginners, the events have become technically quite difficult under competitive pressure of expert fliers. Pennyplane is the latest effort along this line, and it is rapidly moving in the same direction. It is very difficult to help beginners learn contest flying without limiting entry to fliers with little experience!

Florida Flying: Indoor builders in Miami, Florida have banded together in the Miami Indoor Aircraft Model Association. MIAMA is

Pete Andrews shows off the Paper Stick job flown at Lakehurst. He flew to a first place in the 1972 Indoor World Champs this summer.



an active, gung-ho group which has set up an ambitious contest season which began in October. Contact Dr. John Martin, 3227 Darwin St., Miami, Fla. 33133, for more information.

BOB HATSCHKEK GADGETS AND EQUIPMENT

Optical Tracking Station, Mark II: Knowing exactly where a free flight lands is the first step in speedy retrieving. The wisdom of that statement is obvious enough. The question is how do you do it? And one very good answer is with an optical tracking station like Frank Paulin's, which was described in this column last April. This unit consisted of a pair of binoculars, a telescopic rifle sight, and a good compass assembled with a variety of photographic clamps to the pan-head of a camera tripod.

With eight members competing in the U.S. Free Flight Team Selection Finals at Caddo Mills, Texas last summer, the Brooklyn Sky Scrapers put in more than 100 official flights. The winds got as high as 30 mph on all three days. Thanks to Paulin's tracking station, they didn't lose a single model even though they had at least two chases that went five miles!

Experience gained with the tracker at that meet has led to some modifications and improvements, and two more have been built (see photos). The new trackers are much more rugged, provide a much faster and more accurate reading than the compass originally used, allow quick dismounting of the binoculars for other use, and cost less. Building one, or better yet, a pair of trackers, would make an excellent club project for the winter. Chances are some of the members already have suitable binoculars, camera tripods, and maybe even a rifle scope. No modifications are necessary on the optical equipment, so they can always be used for their original purposes. And the tripod additions, which are easily removable if desired, don't get in the way of camera work.

If you don't already have a tripod, you don't need a very good one. It should have an elevating center post, be tall enough for the user's comfort, and must have a pan-tilt head, though the head does not need the "flop" feature that allows a camera to be switched from horizontal to vertical. A suitable tripod could be bought for as little as \$10 new, less for a used one. The tripod shown in the photos is a Star D "Conquest" acquired second hand about ten years ago, in need of minor repairs, for \$5. Price for a new one today is \$20, but it's better than is necessary.

The rifle scope is a Bushnell 4-power x 20-mm scope for a .22-caliber rifle (No. 70-3000); the one shown cost \$15. An updated model with the same number has just

been introduced at \$17. Similar scopes good enough to do the job can be bought for as little as \$8—and don't forget to look in pawn shops.

A variety of binoculars have been used (almost any pair seems to fit the clamp). The pair in the photos is Binolux 7 x 35 wide-angle (No. 4035) priced at \$27. The clamp is a Selsi No. 546 Binocular Mount, available for a few dollars in many camera stores. The final item on your shopping list is a four-in. diameter, 360° protractor for about 80 cents.

Depending on the tripod you're working with, you may have to figure out a different way of building a tracker, but here's the way the Mark II Tracker was made. The center bar was trimmed out of the protractor (ID is 2-11/16 in.), and this was mounted on a 1/8-in. thick ring 4-1/8 in. OD and 2-1/4 in. ID. This ring can be aluminum (more rugged) or plywood (easier to make)—both have been tried and both work. A white cardboard ring was sandwiched between the two to improve legibility of the protractor calibrations. This also has an inked circle on it to obliterate the counter-clockwise calibrations and thus eliminate confusion. A 2-5/8-in. OD clamp ring (with ID to clear the tripod center post) goes under the protractor ring, allowing the latter to rotate freely until the three knurled-head cap screws (in holes tapped in the bottom of the tripod head) are finger-tightened. This allows the rig to be set up, aligned with the aid of a compass, and left that way for the day. The clamp ring should have some provisions for keeping the protractor ring centered. The one shown was flanged in a lathe to provide this function.

The only other modification on the tripod is to mount a rugged pointer on the swiveling

(Continued on page 56)



FF tracker consists of binoculars, rifle-scope, and protractor mounted atop camera tripod.

Pointer gives readings to 1/2 degree on the four-in. protractor, this really helps in rough-country retrieving.



85% of 1st Place Nationals Winners Used SIG Balsa

**YEAR AFTER YEAR THE MOST DEMANDING MODELERS IN THE
COUNTRY USE SIG Balsa. FIVE TIMES MORE THAN ALL OTHER
BRANDS COMBINED.**

POSITIVE PROOF OF THE QUALITY OF SIG Balsa.



FRANK "BUD" NOSEN

**1st PLACE WINNER
R/C SCALE**

1972 NATIONALS

**SIG Balsa
SIG SILK
SIG SUPERCOAT DOPE**



CLAUDE McCULLOUGH

**WINNER
STERLING AWARD**

BEST SCALE MODEL

1972 NATIONALS

**SIG Balsa
SIG SILK
SIG SUPERCOAT DOPE**

SIG MODEL AIRPLANE HARDWARE

MOUNTING BOLTS

COMPLETE WITH NUTS & WASHERS

Package of 4



Round Head

2-56 x 3/8.....	15¢
2-56 x 1/2.....	15¢
2-56 x 1.....	15¢
3-48 x 3/4.....	20¢
4-40 x 3/8.....	20¢
4-40 x 1/2.....	20¢
4-40 x 3/4.....	25¢
4-40 x 1.....	25¢
4-40 x 1 1/2.....	25¢
6-32 x 1.....	25¢
6-32 x 1 1/2.....	30¢
8-32 x 1-3/8.....	25¢
8-32 x 1 1/2.....	30¢



Flat Head

2-56 x 3/8.....	15¢
4-40 x 3/8.....	20¢
4-40 x 1.....	25¢

SOCKET HEAD BOLTS



With Wrench

4-40 x 3/8 Pkg. of 4... 45¢
4-40 x 3/4 Pkg. of 4... 49¢
6-32 x 1 Pkg. of 4... 55¢
8-32 x 1 1/4 Pkg. of 4... 59¢

Complete with wrench and nuts and washers
 4/40 x 3/8 Pkg. of 4... 49¢
 4/40 x 3/4 Pkg. of 4... 55¢
 6-32 x 1 Pkg. of 4... 59¢
 8-32 x 1 1/4 Pkg. of 4... 65¢

WOOD SCREWS

Package of 12



Flat Head 15¢

#1 x 3/8
#2 x 3/8



Round Head 20¢

#1 x 3/8
#2 x 3/8
#3 x 3/8

BLIND MOUNTING NUTS



2-56
3-48
4-40
6-32

PKG. OF 4 25¢

NEW - NOW AVAILABLE IN TWO SIZES NYLON STEERING ARM NYLON NOSE GEAR BEARINGS

1/8"
5/32"



49¢
each

1/8"
5/32"



35¢
each

ENGINE MOUNTING SCREWS

FOR MOUNTING ENGINES TO WOOD ENGINE MOUNTS

Package of 6

No. 2 x 3/8"
No. 2 x 1/2"
No. 4 x 3/8"
No. 4 x 1/2"
No. 6 x 3/4"



20¢
Pkg.

HARD SELF TAPPING BOLTS

FOR MOUNTING ENGINES IN ALUMINUM MOUNTS



Package of 6

4-40 x 1/2
6-32 x 1/2

20¢

New TUF-STEEL R-C LINK

DEEP-CUT STANDARD 2-56 THREAD



ALL NEW TUF-STEEL R-C LINK CAREFULLY MANUFACTURED AND PRECISION HEAT TREATED FOR MAXIMUM STRENGTH.

Complete with 10" rod - 2 for 59¢

R-C Link only - 2 for 49¢

AILERON NYLON BELLCRANK

90 DEGREE BELLCRANK MOLDED OF TOUGH NYLON

COMPLETE WITH BUSHING AND MOUNTING BOLT

Pkg. of 2 - 39¢

25¢ each

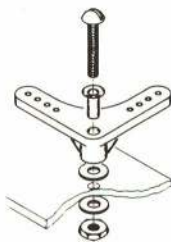

1/2A WHEEL RETAINERS



Pkg. of 4

18¢

FOR 1/16" WIRE

MOUNTING BOLTS WITH BLIND NUTS

COMPLETE WITH WASHERS



Package of 4 each

2-56 x 1/2... 35¢
3-48 x 3/4... 35¢
4-40 x 1... 39¢
4-40 x 1 1/2... 39¢
6-32 x 1... 39¢
6-32 x 1 1/2... 45¢



LOCK WASHERS



Package of 12

No. 2
No. 4
No. 6

15¢

FLAT WASHERS

(METAL)

15¢



4" FLAP OR ELEVATOR CADMIUM PLATED CONTROL HORN



45¢



45¢

OFFSET HORN

C/L
and
R/C

SIG CONTROL HORN



SHORT
MEDIUM
LARGE

HOLES WILL TAKE 1/16" WIRE Pkg. of 2 - 39¢

PRECISION MOLDED OF TOP QUALITY NYLON
 COMPLETE WITH NUT PLATE AND SCREWS

MOLDED NYLON HINGES

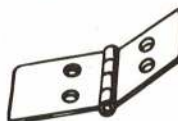

Pkg. of 15 - \$1.25

Pkg. of 4 - 39¢

MOLDED FROM TEMPERED NYLON FOR MAXIMUM STRENGTH. THIN SECTION FOR EASY INSTALLATION. A SMALL AMOUNT OF EPOXY IN THE HOLES WILL SOLIDLY ANCHOR THE HINGE.

SOCKET HEAD BOLTS AND BLIND NUTS

COMPLETE WITH WRENCH AND WASHERS



Package of 4 each

4-40 x 1/4... 69¢
6-32 x 1... 75¢



Send \$1.00 Today for SIG'S BIG NEW CATALOG! The Modeler's Wishbook

NO POSTAGE REQUIRED WHEN ORDERING CATALOG ALONE

THE 1972 FALL AND WINTER SIG CATALOG is the greatest Model Airplane Catalog yet! Over 244 pages, with sixteen pages in full color, devoted exclusively to merchandise used in the building or flying of model airplanes. Features the complete Sig Line, plus practically all other lines available. Hundreds of models are illustrated, including gliders, sailplanes, rubber-powered flying scale, control line stunt and scale, and every type of R-C model. Send \$1.00 today for your copy or buy it from your local hobby dealer. You will agree that it is the best bargain in the model airplane industry.

ORDERING INSTRUCTIONS

SEE YOUR DEALER FIRST!

If he will not supply you, then order directly from our plant. We will ship promptly. To Order, please add \$1.00 for postage and handling in the U. S. Canadian orders please add \$1.50. Minimum order is \$1.00. Please remit by bank draft, check or money order. Print your name and address plainly. Sorry, No C.O.D. shipments. All prices subject to change without notice.

SIG MANUFACTURING CO., INC.

401 S. FRONT STREET
 MONTEZUMA, IOWA 50171



Parts of tracker are simple but need some re-design for different tripods. Total cost, except for binoculars should run under \$25.

part of the pan-head. This should not be on the part which tilts for obvious reasons.

Two holes are drilled and tapped in the binocular clamp to mount a 1/4 x 1 x 4 in. aluminum bar, as shown in the photos. A dovetail to fit the rifle-scope mount can either be screwed to this bar or milled in it (as shown) if you have the equipment. From here on, assembly is straightforward.

With the tracker set up on the field, follow the model in the binoculars. When it lands, align the scope's cross-hairs right on the spot. A glance down at the point immediately gives you the compass bearing. This vital bit of data can be used in several ways. You can follow it straight across hill and dale to the model. If you can't travel a straight line (maybe you're driving and the road doesn't go just that way), you go out to the approximate area, sight your compass back on the tracking station (the model's heading minus 180°), then turn around and follow it to the model. Or you can use the heading to locate the line on a large-scale map such as the U.S. Coast and Geodetic Survey maps.

A second tracker a few hundred yards to one side will provide a second bearing that can give you range as well as direction. The two slightly differing lines drawn on a map will cross at the point the model landed. Or you can walk out one line taking backsights on the second tracker until you are just where the two sightlines cross.

Remember the importance of accuracy. At a distance of one mile, an error of 1° puts you 92 ft. off the target. But with a four-in. protractor, you can easily read to 1/2° and error should be no more than +1/4°. That should be good enough to get it back for the next flight.

BOB STALICK GLIDER AND RUBBER

FAI Free Flight Team Selection—A Commentary: All the dust has cleared, the winds, I hope, have died down, and we have selected a good team to represent the U.S. in Austria next summer. As could be expected, those of us not heading to Europe have rationalized, excused, and otherwise compensated for our standard of performance. But this is the time to take a good look at the total program in an effort to grow from our experiences.

The prime goal behind the FAI program is to field the best team the U.S. can against the best of the other countries' modelers. There are other secondary goals such as involving more fliers in the program and providing a base for competition and equipment development. There are human and practical limitations as well. Scheduling vacation time for the contestants, being able to afford the time and money it takes to be competitive, equipment, practice and travel time, family commitments, all must be considered.

Any program should stress the prime goal first, then secondary goals, all with an open mind toward the stated limitations. For the past two FAI finals, the site was dictated by two points: Is it reasonably central in location, thereby available to a majority of contestants? Did manpower to operate a meet with over 100 contestants exist near the site? Neither of these points addresses itself directly to the prime goal.

Next, the finals contestants are not allowed full knowledge of what organization to

expect upon arrival at the site—things such as where the flying will be conducted, where and when processing will be held, what the standard operating procedure is and, in too many cases, who is eligible to fly. Taking these problems into consideration, I propose a revamp of the program for 1975 to minimize the existing problems and to select a team which will be competitive in Europe.

Proposal for 1975 FAI FF Team Selection: Beginning on or around April 1, 1973, and continuing for four months, any club may hold Qualifying Trials. These would involve seven rounds of flying requiring a minimum of 14 min. flight time to advance to the next step, the Area Semi-Finals. This is no different from current practice except for the addition of rounds. The purpose here is to involve newcomers, set a minimum level of performance, and to establish early the concept of rounds flying.

On Labor Day weekend, 1973, seven or eight (as before) Area Semi-Finals would be held. The top contestant in each event plus all Formula competitors and those who qualify under the 95% rule would advance to the next level. The Area Semi-Finals would be flown to strict International FAI Specifications, including seven rounds with fly-offs to break ties if necessary, weight and area checks of all models, etc.

Regional Finals (a new level) would be held in three locations (East, Central and West) for all Area Semi-Finals qualifiers with no geographical restrictions. This level would be held in the Spring of 1974. Previous team members would be allowed to enter at this level. Anticipated entry for each event would be around 20 contestants, making it manageable from an organizational point of view. Again, this meet would be operated in strict accord with International FAI Standards, utilizing seven rounds with fly-offs to break ties. The top three contestants in each Regional Final event would advance to the Finals.

The Finals, to be held Labor Day weekend, 1974, should be at a site in the U.S. chosen solely because it is most nearly like the International site as regards weather conditions and terrain. No other criteria should be considered. The finals will follow strict FAI International Standards. Expenses for the 27 contestants will be substantially offset, if not totally so, by the AMA FF FAI fund. Since the number of contestants is not large, nearly any free flight club could operate the meet. Since we have chosen the best fliers in each of the three geographical areas of the country and brought them together at an "ideal" site, the best team should be the result. Flying under Internats specifications would also provide the necessary contest experience needed to be competitive with the Europeans.

There are a couple items which also need to be instituted before any program is established for 1975. A system by which fliers must commit themselves to fly before an established cut-off date. This could be that at least 90 days before the Regional Finals each qualifier must state whether he will or will not attend. For those who want to attend, a deposit of \$25 would be required—\$15 would be refunded, the remaining \$10 would pay the entry fee. Contestants who don't attend would forfeit the \$25. This requirement would allow notification of alternates, giving them time to respond and plan their trips. Hardship cases would be appealed to the FAI Committee for their final ruling. This procedure would minimize the current no notification or short time notification situation. In addition, if a contestant qualifies in more than one event at the Regional Finals level, he would have to state which events he would compete in at the Finals. This would eliminate the current situation where a flier competes, for a short while, in more than one event and then drops one to concentrate on the other, keeping another alternate contestant from entering.

A Standard Operating Manual must be developed by the program administrator which gives a time line for operations, suggests contest procedures, and offers experiences of others who have operated FAI Finals. If this were available, the CD would not have to "reinvent the wheel" every two years.

In brief, there it is. Additional details of the proposal are available from this columnist, as well as the welcoming of any comments or criticisms.

GUEST WRITER: FUDO TAKAGI SCALE

The Exceptions: Scale modelers appear on the surface to be a separate breed. However there is an old Spanish saying: *No hay rosas sin espinas. No hay reglas sin excepciones.* There are no roses without thorns and no rules without exceptions. One of the exceptions, hereabouts, is Clarence Mather. He won first in Peanut Scale at the 1972 Nats with a Nesmith cougar, tied for third in Indoor Scale with a Stormavick (February 1970 AAM) and won Indoor Rubber.

Then take the recent U.S. Finals at Caddo Mills, Texas, I attended. There one of the finalists, Don Edson, introduced himself, not as a Wakefield flier, but as a fellow Peanut Scaler.

A recent issue of the "Flying Aces Club News" was featured as an Old Timers issue. It noted that Non-flying Scale is a category in the AMA rule book. Could solid Scale make a comeback? Anyone for a hunk of white pine?

Rubber Events: This year, Outdoor Rubber became a separate category at the Nats. I can remember when Rubber Scale reigned supreme in the '40s, and there was Hank Struck winning. Here in this part of California there seems to be more rubber scale models flown, perhaps due to Peanut Scale, plastic props and the fact that rubber scale models seem to fly better than they did in the old days. Of course, having the likes of Walt Mooney, Clarence Mather, Bill Hannan and Bob Peck of Peck Polymers, in town helps immensely. Note, too, that the Rubber Scale Speed by the Flightmasters has become an



Granger Williams had that fast-flying Crosby Racer.

Prize winning Folkerts by Jack McCracken even had retract.





Charming Focke-Wulf Stösser by Bill Kresek. This picture is from the 1951 Dallas Nationals!

A most versatile modeler, Fulton Hungerford with his meticulous Loening Amphibian.



annual event. On the East Coast, The Flying Aces Club has a similar program.

At a recent Indoor record trial at the Santa Ana blimp hangar, I told Joe Bilgri about the up and coming Speed events and elicited the following. Joe recalled that Rubber Speed (non-scale) was a big deal at the California State Fair back when. At least 200 contestants would line up shoulder to shoulder and heave their speed models! Upon reaching the finish line 120 ft. away, the models would go every way but across. Bud Romack attested to seeing movies of the event.

Scale Rubber was also king at the State Fair. A beautiful perpetual was awarded, and the last recipient was Russ Seley before the event became a casualty of World War II, never to return. So much for the good old days.

Flightmasters Speed Event: The Second Annual Speed Event by the Flightmasters was a wild affair—bashed models, models that refused to cross the finish line or took the long way across like misguided turtles. Take Bill Hannan's Bede 4 peanut, which caught a little lift and made some wide circles before going across, Bill won the slow poke award replacing Walt Mooney and the truculent turtle for this annual.

When the sounds of battle died down, the following were winners of the spoils: Jack McCracken took first in Rubber Scale with a beautiful model of Rudy Kling's Folkerts. Granger Williams, of FAST Club fame, had the fastest time with his Crosby Racer. Fulton Hungerford flew an exquisite Loening Amphibian—the ribs were built up like the real thing. Granger Williams also won the special Peanut award which just happened to be peanut size.

In Profile Scale there was quite a variety from a peanut-size Rivets to a huge Dayton Wright Racer four times as large with a Bonzo, a GB, a B-70, an R.E.P., etc., in be-

tween. Emerging as a victor was Mark Smith with his first rubber scale speed model, a Crosby Racer—quite a far cry from the manufacturing and flying of RC slope soaring gliders. In second was Jack Lueken, another first timer, with a B-70. Rounding third, flying a F-86 (via the proxy route) was Doug Mooney.

One thing about these Flightmasters' bashes—every qualifier wins. There are all kinds of merchandise, free pop, and even an occasional beer for the boozers. Now I am looking forward to the next one, just like everyone else who was there.

Radio Control

Editor's Note: Correspondent Lowe was busy flying and reporting the Nats at the time copy for December issue was due. Don't miss previous issue with Don's excellent story of the 1972 RC Pattern Nats.

CARL MARONEY GLIDERS AND FAI

Computer Engineering: Soarcraft has developed a 1/6 scale Kestrel 19 which is an advanced sailplane with outstanding hauling qualities and design features.

The full-size Kestrel 19 is a development of the earlier 17 meter span Kestrel produced by Glasflugel. Production of the 17 meter version began by Slingsby in 1969, but it was soon realized that performance could be considerably increased to meet the requirements of Open Class pilots and give the significant performance differential required when compared with Standard Class aircraft. The high performance of the 19 meter version was obtained by increasing the span and aspect ratio and improving the wing fuselage fillet. In developing these modifications, a number of other improvements were introduced together

Chicago startlet, Diane Spencer came to the Soaring Nats (reported elsewhere in this issue) to help inaugurate release of a new glider kit. Model is close to scale of the Kestrel 19.



with a significant improvement in the payload. The first 19 meter version of the Kestrel 19 was produced as a special development with a carbon fiber main spar; it is the first aircraft structure to be fully certified with this material. Newer 19 meter Kestrels have the well proven uni-directional glass fiber spar.

The Soarcraft model of the Kestrel 19 is scaled, having a wingspan of 134", scale aspect ratio of 21:1, 850 sq. in. of wing area, and approximate flying weight of 50 oz. The wing was designed for model flight characteristics through the use of existing NACA airfoil data plotted by computer, both in airfoil and structural stress design. The development of the wing design evolved over two years of effort and was found most adaptable to the Kestrel configuration.

The fuselage is hand-laid up fiberglass weighing approximately 8½ oz. as molded. Fuselage reinforcement, located only under the canopy section, consists of a 3/32" plywood deck. The canopy tray is vacuum molded from a styrene plastic, and the canopy is 0.060 acetate vacuum mold. Canopy color is blue, an optional accessory of the Slingsby Kestrel 19.

The wing construction is of built-up balsa utilizing two linear spar systems. The spars are essentially eye-beam stress models since vertical grain balsa webs are used between the spars. Wing flexures and strength were designed by computer program to duplicate as closely as possible wing stress and flexure characteristics of the Slingsby Kestrel 19. This design provides the exceptional strength necessary in turbulent air and dive recoveries since wing flexure spreads wing loading throughout the wing length and does not concentrate stress in the root of the wing. The airfoil is a highly modified 6412 with under-camber in the root section tapering to a flat tip.

Tail plane construction is of built-up balsa and is attached to the fuselage by a single pivot pin through plywood reinforcement in the rudder post. Tail plane movement is facilitated through a single pin connected to a vertical pushrod.

The kit, which has just been released, contains an all-white fiberglass fuselage, custom molded canopy and tray, resin filler for wing rod and hardware installation, machine cut wing and stab ribs, complete plans, and illustrated instruction manual. Priced at \$69.95, the kit is available through Soarcraft, 12446 Palmtag Dr., Saratoga, Calif. 95070.

CLAUDE McCULLOUGH SCALE

The Numbers Game: The present RC Scale rules seem to have again confounded predictions as to just what type of aircraft, if any, is favored. Because of the wide variety of model choices by contestants at the Nationals, Bud Nosen's Skyraider, a fairly difficult military

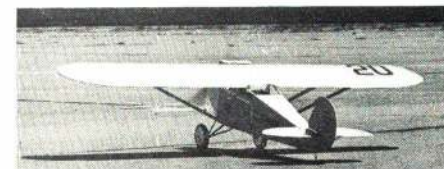

Slow and steady flew Ed Ellis' Ryan M-1.

Ralph Jackson prepares to start his smooth-skinned Windecker Eagle.



Special Interest

FRED MARKS AERODYNAMICS, ELECTRONICS

Starting Batteries: There is nothing quite as disgusting as arriving at the flying field to find your starting battery dead. The No. 6 dry cells are expensive and don't last long. Larger nickel cadmium cells are also expensive. One cell at 1.2 volts may not be enough in cold weather while 2.4 volts from two cells will burn out some plugs. It is also a nuisance to have to carry two batteries: one for the glow plug and another for an electric starter. In addition, even 2.4 volts isn't quite enough to drive some electric fuel pumps convincingly.

A number of solutions come my way, some of which solve part of the problem but usually not all. One solution to the hot-cold starting problem comes from Gerald Reinhard. Purchase two nickel cadmium cells of 1.2 to 4.0 ampere hour capability and connect them in series. Connection to the glow plug in cold weather is direct for 2.4 volts (Figure 1). Connection during hot weather is via the diode. The voltage drop across the diode lights the lamp to indicate proper operation.

A further refinement of the preceding is proposed by modeler Clyde Shelton. By placing either a 10 amp meter across the diode (Figure 2) or a lower reading millimeter with a protective resistor (Figure 3) across the diode, a more precise evaluation of plug current flow is achieved.

We have also seen glow plug voltage obtained from 12-volt starting motors by using a high wattage (at least 10 watts) wirewound voltage dropping resistor. This is extremely wasteful of current. A much more suitable device is available commercially in the form of a DC-DC converter which provides AC current to the glow plug at the usual 2 to 3 amperes, but drains only about 300 milliamps from the 12 volts supply.

We are planning to present a universal rig for all these operations at a future date. It will consist of the following: a DC-DC converter operating from 12 volts and producing 2 amps, AC at a mean 1.5 volts for the glow plug, and a fully rectified 3 volts DC for electric fuel pumps. A companion item will be an automatic shut-off charger for the 12-volt batteries which were developed over a year ago but which I haven't written up yet.



Claude McCullough's fine Shinn 2150 awaits flight at the Nats. Note how the rivets stand up on the model.

A Bonzo, Steve Whitman's early racer, looks like a hard-to-fly model, short span, wide wing, etc. Bob Underwood showed that it flies great. You must keep the CG in its place even if that means lead up front and a heavier model.



subject, won without any complexity scoring factor to protect it from the supposed advantage of a well executed but simple entry. Looking back over past winners and near winners, it can be argued that the multiplication of scale points by flight points results in a wide range of possible outcomes. It is also probable that a good model is a good model, regardless of type or the way the rules are written. The multiplying scoring arrangement has been attacked frequently, but it is interesting to note that neither the Scale Contest Board or its predecessors has received a formal proposal to replace the multiplication method with another procedure.

The exact results of any turnabout in established scoring provisions is difficult to predict. It would take several seasons of operation to discover the hidden hooks, and there would be some. Still, the time may be here to come to grips with this mathematical maze. The scoring sheets now in use look like a cross between a road map and an income tax form. Only veteran Scale people can properly operate a Scale meet. Because the simpler Sport Scale event is available, contest organizers are going to bypass the AMA Scale event if scoring continues to require a computer or a battery of calculating machines.

For openers, why not try the following. Have an approximately 50/50 split between maximum scale points and maximum flight points and add them together for total score. Make scale operations part of the flight score. Judge maneuvers on a ten-point basis without the present divide-by-two patchwork. This would end a lot of the math and probably produce similar results. If you favor jarring out of our well-worn rut and trying a new combination, let your district Scale Contest Board representative know about it and send a copy to the chairman, c/o AMA Headquarters.

Tape Tip: Maxey Hester reports seeing an effective variation on his notched pinking tape tearing idea (this column, October 1971 and August 1972 AAM). At the Scale World Championships in France, South Africa's Colin Jones had a version of Maxey's Ryan STA design which was one of the highest static scored models of the meet. The beautiful rib taping job was made by painting a sheet of Jap tissue with clear dope and hanging it up to dry. A second coat may be applied. This stiffens the paper so that, when it is torn in strips along the serrated edge of a wax paper box, the notches are clean and well defined. Since the strips are pre-doped, they easily adhere to the model by brushing with dope and don't need filling.

Flying Wire Find: Clark Macomber, the Nats Scale Director, had an item at Glenview that looked ideal for the difficult problem of streamlined flying wires. It is an X-Acto product called Plexon, a craft material for weaving and the like. Available in colors including silver, it is a plastic lacing of flattened

oval cross section. The best part is the fibrous core which makes it super tough and unlikely to fracture under continual drumming and vibration as will solid plastic lacing.

Flip Side, Part II: In the October column we had a feature about getting the three letter WW II codes on fuselages correctly. On the subject of markings there is seldom any final word and there are plenty of footnotes. It should be added that one other variation of the basic A (Insignia) BC left side example is possible. That would be BC (Insignia) A on the right side. This was used on airplanes where shape or insignia position didn't leave room, or perhaps someone just thought it looked more symmetrical that way. In any event, the best thing is to try to locate photos of both sides of the aircraft just in case a crew chief with a paint brush had other ideas.

The fabulous Skyraider by Bud Nosen. Last year it crunched, this year it flew fine. Fuselage even has footholds for the pilot to reach the cockpit.



FUSE 10-15 amp slo-blow
CELLS 2-1.2 volt nickel cadmium
DIODE 1N3491
BULB No. 43
HEAT SINK 1/4" aluminum (about 1 x 1 1/2" min.)

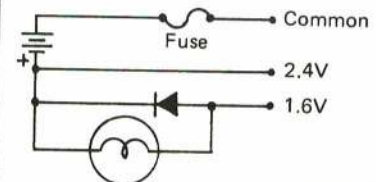

FIGURE 1

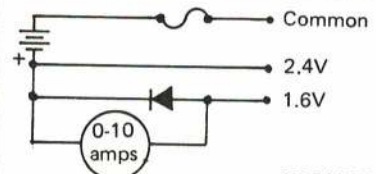

FIGURE 2

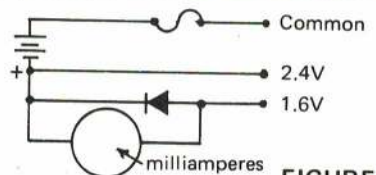

FIGURE 3

NEW from SCIENTIFIC

ROBERT E. LEE

MISSISSIPPI STEAMBOAT

A handsome museum quality wood ship model with carved wood hull and cast metal fittings.

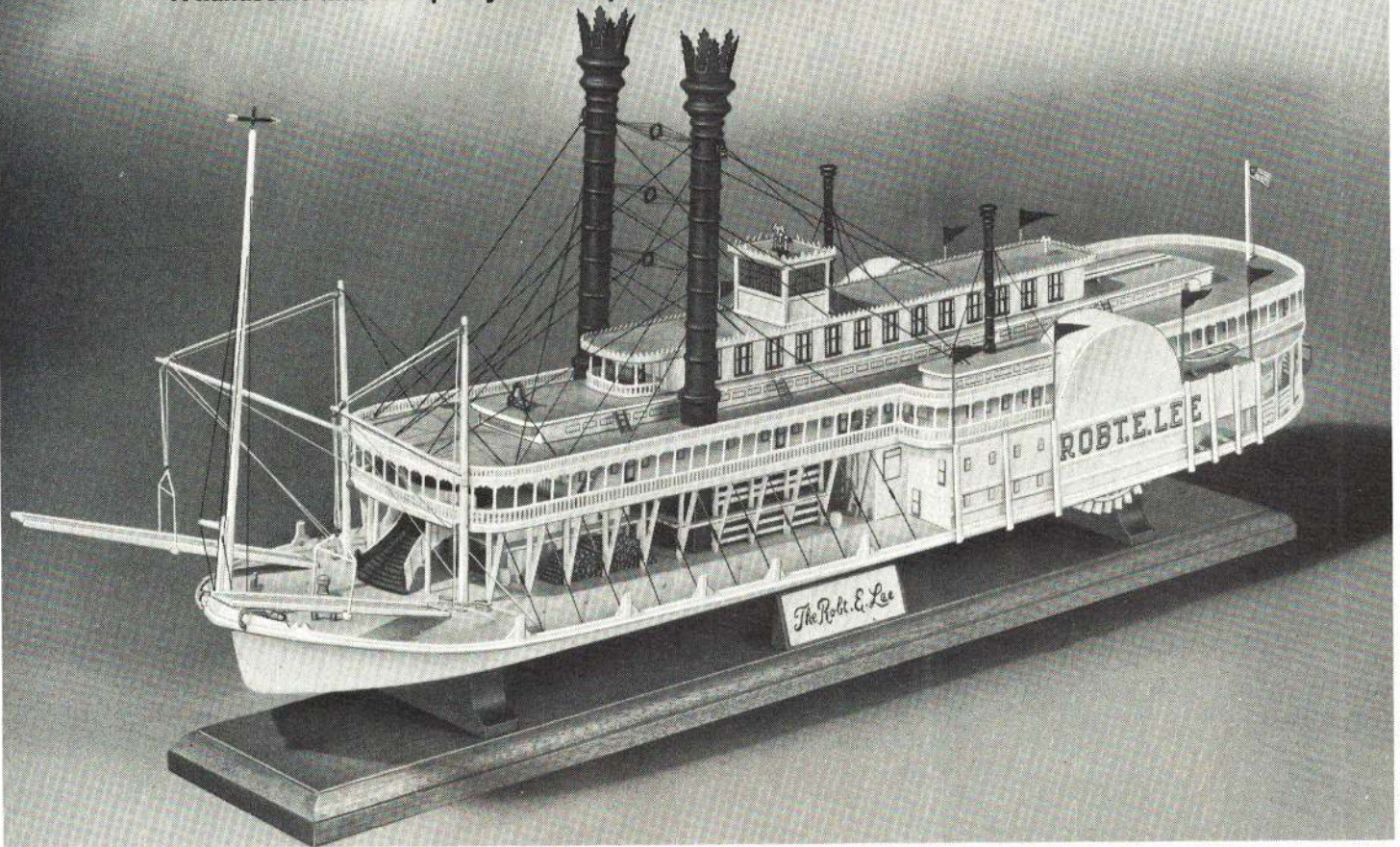

"NO MORE WAITIN' FOR THE ROBERT E. LEE" . . . IT'S HERE!

The most famous sidewheeler of them all is in a great new kit with all the trimmin's to make a scale replica. Months of research with material furnished by the Ohio Historical Society and the Louisiana State Museum make it authentic in every detail. And, anyone, even if they've never built a model before, can easily assemble it, using the easy-to-follow detailed instructions. Back in 1870, the Robert E. Lee was the fastest steamboat on the Mississippi. Now, it's a beautiful wood model Mark Twain would have been proud to own!

Our deluxe kit contains the finest materials available including:

- Pre-carved wood hull, all precision cast metal fittings including anchors, stairway, paddle wheels, ladders, lifeboats, chocks, etc.
- Pre-shaped Smoke Stacks
- Formed Deck Railing and pre-ruled scale Decking
- Colorful Decals and Pennant materials
- Mounting pedestals and beveled wood Display Stand
- Handsome metal nameplate
- Complete step-by-step instructions that make building easy even for the beginner.

KIT NO. 181

24½" Long, 6" Wide, 9" High

\$32⁹⁵

Send for our big colorful catalog . . . 25¢

See Your Dealer. If kits are not available at dealer, you may order direct from factory adding \$1.00 for postage and handling. Outside U.S.A. add \$2.00

SCIENTIFIC

SCIENTIFIC MODELS, INC.

340CC Snyder Ave., Berkeley Heights, N.J. 07922



(PSSSST...
MERRY
CHRISTMAS...
PASS IT ON)

That's what Citizen-Ship and its dealers are doing . . . passing it on this Christmas to modelers like yourself.

That coupon down there is worth real savings on Citizen-Ship R/C equipment now through December 31, 1972. Here's your chance to be Santa to some modeler (or yourself) and give the gift they've been wanting. (We won't tell 'em you got it with our Santa Coupon.)

Just take this coupon . . . the whole page . . . or even the magazine to your Citizen-Ship Dealer, he'll give you \$20 off the regular price of a 6-Channel System . . . \$15 off on a 4-Channel System . . . or \$10 off on a 2-Channel System.

(PSSSST . . . MERRY CHRISTMAS . . . PASS IT ON)

Name _____ Age _____

Address _____

City _____ State _____ Zip _____

Model No. _____ Serial No. _____

Mr. Dealer, Citizen-Ship will honor this coupon with your store's identification attached for the sale from your inventory any Citizen-Ship Radio Controlled System at the following discounts: Model CDS-716-\$20.00, Model CDS-714-\$15.00, Model CDS-712-\$10.00

Offer expires December 31, 1972.

Citizen-Ship

Box 297, Westfield, Indiana 46074

Phone: (317) 896-2561

NEW *Du-Bro* MUFF-L-AIRE®

FOR '73 Patent Pending



MW-750

- **EXTREMELY COMPACT!**
- **FULLY ADJUSTABLE NOISE LEVEL AND BACK PRESSURE FOR BETTER PERFORMANCE!**
- **ADAPTS TO ALL ENGINES FROM 29 TO 60**
- **QUIETER THAN OTHER TYPES OF MUFFLERS!**

Used on the 2nd place winner in the '72 Nats (Mark Smith, class B pattern), the Dubro Muff-l-aire made a mark in the history of model plane engines. Varying the number of plates takes only minutes and controls noise level and back pressure to your desire. The ugly monstrous old fashioned muffler is now past history. Result—a much neater looking plane. Model MW-750 for .60 Webra engines fits on with only two furnished bolts.



MU-795
Shown mounted on H.P. 60 engine.
Pat. Pend.

UNIVERSALLY ADAPTABLE!

Model MU-795 includes perforated steel clamping strap with worm-drive screw and fits a wide variety of engines. Also has hidden "no drift" positioning plates to hold muffler firmly in alignment on engine.

PRICE \$7.95

PRICE **\$7.50**

NEW! *Du-Bro* SOFT CUSHION, LOW-BOUNCE TREAD TIRES

SIZES 3 1/2", 3 1/4", 3", 2 3/4", 2 1/2", 2 1/4", 2", 1 3/4" DIAM.

Newly styled, hand inspected, top quality tires with treads will lend a neat appearance to your model. The fine appearance and matchless workmanship in this new tire design offers a highly pleasing "scale" look.

Du-Bro smooth surface tires still available!



MADE IN U.S.A.

Designed and manufactured by *Du-Bro* PRODUCTS INCORPORATED
WAUCONDA, ILLINOIS 60084

For Your R/C Flying Fun!



Have Fun--
Fly the Simple System:

pulse commander



The Pulse Commander Rudder-Only Systems now have greater flexibility than ever. Connectors are wired into the Flite Paks to let you switch receiver from plane to plane. Latest Flite Pak gives 50% or more flying time per charge. COMPLETE Flite Pak weights, including nicads, run from 2.5 to 4.8 oz. New transmitter design has 50% more power output.

FULLY PROPORTIONAL--Pulsing rudder follows the movement of your stick by dwelling longer in left or right.

SIMPLE--Easy installation; actuator has only one moving part. Minimum maintenance required.

INEXPENSIVE--Initial cost of system includes nickel cadmium rechargeable batteries with charger. Transmitter and receiver can be used in many different installations.

VERSATILE AND LIGHT--See chart below.

PULSE-COMMANDER R-O SYSTEMS

Completely wired and tested, with transmitter, receiver, actuator, nicad battery airborne pack and charger, switch and connectors. Transmitter battery not furnished.

10G 15--Baby System '72	\$69.95
10G 15T--Baby Twin System '72	\$72.95
10G 16--Standard System '72	\$71.95
10G 17--Stomper System '72	\$74.95
26.995, 27.045, 27.095, 27.145,	27.195

Please Specify Frequency

R-O PULSE HANDBOOK WITH UPDATED CATALOG

Only \$1.00

Handbook has expanded data on How Pulse Works, Installation, How to Fly -- and much more. Most complete information on Pulse Rudder-Only available anywhere.

New catalog is completely updated. Includes many items from major manufacturers.

Price is \$1.00 via THIRD CLASS BULK MAIL. If you wish faster delivery, add 50¢ for turn around FIRST CLASS service.

ACE RADIO CONTROL, INC. * BOX 301 * HIGGINSVILLE, MO. 64037

NAME _____
ADDRESS _____
CITY _____ STATE _____ ZIP _____

QUANTITY	STOCK #	NAME OF ITEM	PRICE	TOTAL

Master Charge or BankAmericard No.

Add \$1.00 shipping-handling for direct mailorders except catalog

THROTTLE CONTROL SPECIAL!

For a limited time we will add the KR D Throttle Control, and make the transmitter conversion for the Fast Pulse button, for only \$25.00 on direct orders from customers for a Standard or Stomper Unit. This is a savings of \$6.00.

Simply ask for KR D SPECIAL 72-25 and add \$25.00 to your order. (Offer not good for Baby or Baby Twin).

Good until December 31, 1972.

FLITE PAK WEIGHTS & RECOMMENDATIONS

Complete weight of each unit and suggested application:

Unit	Weight	Recommended
Baby	2.5 oz.	Pee Wee .020 Up to 48" gliders
Baby Twin	2.7 oz.	Tee Dee .010-.020 Up to 72" gliders
Standard	4.4 oz.	.049 to .10
Stomper	4.8 oz.	Tee Dee .049-.23

ACE MINI FOAM WINGS

These jobs are being used by more and more modelers to come up with their own designs. See recent issue of AAM for P38 and RCM for Mr. Mulligan. Ideal for 1/2A Racing-and other planes of semi-scale or fun types.

Constant chord measures 35" span, 5 1/2" wide, area 192.5. Weighs 3+ ounces.

Taper section is 35" span, center 5 1/2", which tapers to 4"; area 166.25. Just over 2 ounces.

13L 166--Ace Mini Foam Taper Wing	\$2.95
13L 192--Ace Mini Foam Constant Wing	\$2.95



DICK'S DREAM KIT

Highly Recommended for Beginners

- † 34" Foam Wing--Moulded sections
- † Top grade die-cut wood parts
- † For .020 engines
- † Commander Baby or Baby Twin
- * Owen Kampen design

No. 13L 100--Dick's Dream Kit \$6.95



ACE HIGH GLIDER KIT

- † 70" Foam Wing -- Moulded sections
- † Precision Machine cut and sanded wood
- † For .049--Power Pod parts supplied
- † Recommended for Rudder-Only
- Standard or Stomper Commander
- * Owen Kampen design

No. 13L 104--Ace High Glider Kit \$14.95



SKAMPY KIT

If you have mastered Rudder-Only pulse proportional flying, and are looking for new ventures, the Skampy is for you. Resembles a stand-off Goodyear Scale Racer. Owen Kampen touches in both the design and kit assures the experienced modeller of a satisfactory RO pulse experience. It is NOT recommended for beginners.

Has 30" span wing cut from Ace mini foam tapers. Construction of the fuselage is a bit harder than a box type, but still simple for modellers with experience. Fuselage is 23 1/2", recommended power is Tee Dee .020. Recommended radio installation is Commander Baby Twin. This makes total weight of 12 to 13 oz.

Kit contains taper foam wing set, precision band sawed and sanded top grade balsa and hardwood parts. Bent landing gear, wire for torque rod and plastic bearing, and hinge material is also supplied. Wheels and engine mounting hardware not included.

Full step by step instructions make this a simple job for the experienced RO flyer.

No. 13L 103--Skampy Foam Wing Airplane Kit \$6.95

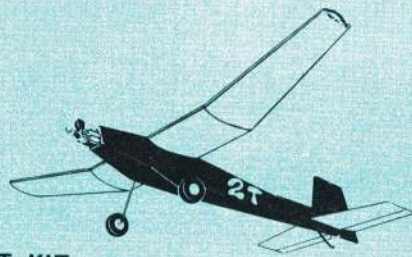

2T KIT By Ron Jacobsen

Uses two sections of the Ace Mini Foam Taper Wings, and one Constant Chord section for a total span of 50 inches, 262 sq. in. Coupled with an .049, the 2T was designed primarily for the two channel Brick type digitals that are on the market, or two servos of any digital system.

Also, when constructed correctly, it performs exceptionally well on Rudder Only using the Commander Standard or Stomper. Motor control can be added to at a later date by using the KR D motor control.

Kit contains three wing panels, all balsa wood completely band sawed and precision sanded, bent landing gear, and miscellaneous parts. Is of the same general high caliber as previous Ace kits. Hardware for hinges and linkage and wheels is left to the buyer.

No. 13L 106--2T Foam Wing Airplane Kit 14.75
No. 13L 206--Three Foam Wing Sections 5.00 For 2T

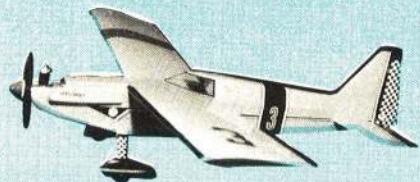

UPSTART 1/2A RACER KIT

- † Midget Racing Just For Fun!
- † 34" span, 6" chord, 200 sq. in. foam wing
- † Top grade band sawed wood
- † .049 to .051 Tee Dee Engine
- † Two channel operation
- * Owen Kampen design

No. 13L 102--Upstart Custom Kit \$10.95

NOW--LOWER PRICE!



**digital commander
KIT**

* Two channel system using IC's and latest state of the art; may be expanded to 4-6-8 channels.

* Receiver-Decoder (2) will work with ANY modern 4-6-8 channel digital transmitter on same frequency! Reads aileron and elevator signals--ignores the rest.

* Receiver-Decoder (2) works any modern digital servo.

* Receiver-Decoder (2) offer inexpensive way to go with your present system for glider, plane, boat or car: use with extra servos you already have. Or use our combo flite pak: receiver-decoder, two servos, etc.

* Available on the following frequencies:
27.995, 27.045, 27.095, 27.145, 27.195
53.100, 53.200, 53.300, 53.400, 53.500

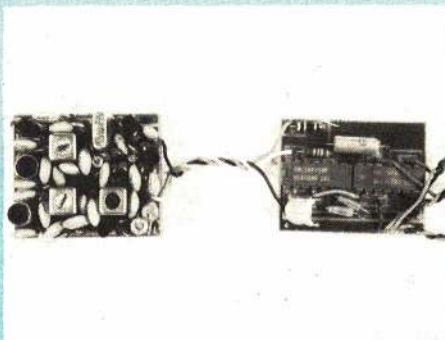

**digital commander
RECEIVER DECODER (2) KIT**

IC's simplify wiring and set up of 2 channel decoder. Receiver is exceptional double tuned front end using discrete components. Complete with detailed step by step instructions.

No. 12G20--Digital Commander Receiver-Decoder Kit (2) \$27.95
(Less case, connectors, switch)

Please Specify Frequency

No. 19L50--Deans gold plated 4 pin connector set .95

(NOTE: See D & R connectors elsewhere)

No. 40L252--CW DPDT Slide Switch .59

No. 30L21--Switch Guard for above .39

No. 21K30--Formed plastic Case for Receiver-Decoder. (All models) 2.00



**digital commander
SERVO KIT**

Housed in the D & R Bantam DS3P mechanics, uses WE 3141 IC for ease in assembly. Kit contains motor, pot, wiper and all components required, with step-by-step manual.

No. 14G20--Digital Commander Servo Kit \$25.95

No. 14G20L--As above, except with D & R DS2P Linear Mechanics (Less connectors) \$26.95

**digital commander
FLITE PAK KIT COMBO (2)**

If you intend to use Commander Digital (2) with your multi digital transmitter, all you need are the receiver-decoder and 2 servo kits. Combo offers savings over kits purchased individually. Includes 3 connectors, switch, hookup wire for cabling. Everything you need to make complete 2 channel-2 servo pack for your sailplane, boat or car, except batteries.

No. 12G30--(2) Flight Pak Combo \$59.95
No. 12G30L--As above, but with D & R DS2P Linear Mechanics \$61.95

Please Specify Frequency

**digital commander
2 CHANNEL TRANSMITTER KIT**

IC's make the encoder a cinch, and easy conversion later to 4 channel. Built up to a standard of excellence; not down to meet a price. Complete kit with step by step instructions.

No. 11G20--Digital Commander 2 Channel Kit \$49.95

Please Specify Frequency

2 CHANNEL KIT COMBO

Consists of Transmitter Kit, and all parts of the Flight Pak Combination.

No. 10G2--Digital Commander 2 Channel Kit Combo \$109.95

No. 10G2L--As above, except with D & R DS2P Linear Mechanics \$111.95

Please Specify Frequency

BATTERY & CHARGER OPTIONS

While alkaline energizers may be used for Flite Pak, 450 ma Nicads are recommended--4.8 volts.

38K33--Nicaid 225 ma Cylindrical cells 2.25

38K50--KRD Flat Pack for above (4) 1.00

38K35--Nicaid 450 ma Cylindrical cells 2.50

38K8--D & R Square Pack for above 1.95

38K77--XL-ent 4.8v 500 ma button pak 8.98

34L10--XL-ent 225 ma charger kit 3.95

34L11--XL-ent 500 ma charger kit 3.95

34K22--Varicharger kit 7.95

34K21--Varicharger, assembled 9.95

(Varicharger will charge both 225 and 450 ma and other packs)

No. 38K54--Mallory 1603, 9 volt Transmitter Battery 2.25

NEW! NEW! NEW!

**digital commander
4-6-8 CONVERSION KIT**

You have been asking for this--a kit to let you convert your Digital Commander receiver and 2 channel decoder or 2 channel Flite Pak to more channels. Here it is!

Uses the same reliable proven receiver front end--which has won praise in all sections of the country for its selectivity and sensitivity. Changes on the receiver board at the rear end are minor.

The 2-4-6-8 Decoder requires a new PC board, new IC and some additional components. Simple to wire. An 8 bit chip is used (Cost is only a bit more than a 4) so you are not limited to just a 4 channel expansion as originally planned. You can go on up to 8, if your transmitter will!

Now use your Digital Commander Flite Pak for 1, 2, 3, 4, 5, 6, 7 or 8 channels--depending on your transmitter (Must be one of today's IC units with conventional clocking). Unused signals are simply ignored.

Kit consists of basic components. New IC, PC board, all other required electronic components with complete instructions. No connectors supplied.

No. 12G8--4-6-8 Channel Conversion Kit \$12.95

TRY YOUR DEALER FIRST--if he does not have it, order direct using coupon for fast and courteous service.



Dear Friend:

Some Digital Commander news first: Reduction in the price of our 2 Channel Flite Paks and Combos leads the list. The best part of that news is that this reduction was made possible by your acceptance--we MUST order in larger quantities, and can pass the savings on!

Acceptance is really too mild a word. The receiver portion is getting quite enthusiastic acclaim as one of the most selective and most sensitive available today. The servos are rated tops in response and resolution. So much so that stick slop translates into motion!

Next juicy bit is that the conversion to 4 channel turns out to be more. It may be used as a 4, 6 or 8. Fred Marks had planned to use a 4 bit chip. Since the price of an 8 bit was only slightly more, he decided to go the 8 channel way. Result is that our conversion kit gives you a bonus of more channels--if you want them. The Receiver-Decoder works with most modern IC transmitters of conventional clocking. You don't HAVE to use 8 channels. If 3 or 4 is all you want, just use them. The remainder simply get lost.

Speaking of acceptance--The PULSE Commanders are coming in for an increasing share of it, too. A father writes that his 8 year old son has soloed successfully with a Commander R/O job; that probably now there will have to be two pulse outfits in the family, since Dad wants to fly at the same time. Dad just had successful open heart surgery and Pulse Commander flying is part of the therapy!

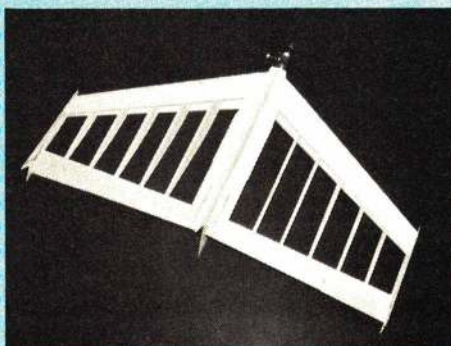

Above photos are a part of a series built by Dick Erickson of Mundelein, Ill. All but one is a foam wing job--and ALL are R-O ships. Aileron-only Delta Shrike, T-Foam, Foamdecker, Bi-Foam, Cana-Foam (a canard). Others are on the drawing board or in the works. The Shrike brings a lot of doubters to their feet: They simply don't believe that the Stomper actuator will handle those big ailerons at the speed this job flies--which Dick says is "dam fast".

Dick says: "With the reliable Commander R-O system and those good foam wing configurations you have, it seems there are unlimited design possibilities."

Have YOU tried Pulse and/or one of the Ace foam jobs?

Keep 'em pulsing,

Yours sincerely,
Paul F. Runge
Paul F. Runge



I. M. products

DISTRIBUTED BY
WORLD ENGINES



INSTRUMENT PANEL GAUGES



These instrument panel gauges give you that extra added touch of realism for the scale builder.

12 MM
9 MM
7 MM
5 MM.....\$1.25

PUSH ROD EXIT GUIDES



Here is a nice long exit guide for that servo with the added throw. These also have a streamline fairing on one end for that extra touch.

Package of 2.....\$.39

FUEL PRIMING BOTTLES



A must for every field box. These come in two styles, the standard type and the deluxe which features a twist-loc shut off.

Standard.....\$.95
Deluxe.....\$1.50

H-CLAMPS

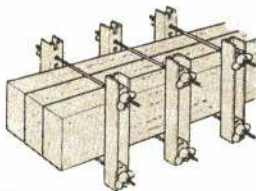

These clamps have many uses such as laminating wood or holding your fuselage sides in place while epoxy or glue is drying.

Price per clamp.....\$2.49

NOSE GEARS

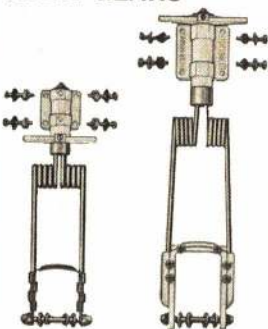

These are made of Piano Wire and are very strong. They come in two sizes: the small one is for use with .09 - .35 engines. The large one for .40 - .60 engines. Both have a good looking and sturdy wheel gate.

Small.....\$2.95
Large.....\$3.95

FILTER AND WEIGHT



Here is that insurance for keeping dirt out of your carb and engine. You get one inline filter and one clunk filter for the tank.

Price.....\$1.25

FREQUENCY FLAGS



By far, these are the most popular flags on the market today. Snaps easily onto the transmitter antenna and comes in all frequency colors.

27 MHZ
53 MHZ
72 MHZ.....\$.59

HAND FUEL PUMP



"The new IM Hand Fuel Pump is the greatest thing! I've had one for three contests now and it seems to be able to handle even the hot fuels OK, so the racing people I've shown it to all want one."

Pete Reed
Price.....\$10.00

CONNECTOR



This nylon connector allows for various long or short adjustments between throttle, elevator, rudder, etc.

Price.....\$.70

DUMMY PILOTS



These bust style Pilots are completely painted and ready to install.

Med. Jet Pilot
1/4" scale.....\$1.50
Med. Combat
WWII Pilot.....\$1.50
Small Jet Pilot.....\$1.20

SNOOPY

(Continued from page 48)

wheel landing gear is used to keep the construction and control linkages simplified. Many fliers would like to get away from the trike gear high and low wing lookalikes but still have good performance. Rough grass fields have been no detriment to the ground handling ability of the Snoopy Trainer.

The Top Flite Headmaster kit was used as the basis for the design and modified into a not so lookalike. After the mods were made, the model looked ugly and dead. A Snoopy pilot was carved from a block of balsa and placed onto the top of the wing, the model livened up, hence the name "Snoopy Trainer." A great deal can be learned from flying this plane and it will forgive you for all but the most egregious errors.

Construction is so simple and straightforward that you can build it from the plans without reference to any explanatory text. There are a couple of points which might bring up a question in your mind, so let's see if they can be cleared up beforehand.

The fuselage is a typical "slabsider," but can be disguised. The 3/16 square longerons give an excellent gluing surface for the top and bottom sheeting; then when the box-like structure is completed, the corners can be rounded. Section A-A shows the cross section of the fuselage as it would appear at that point. The rounding of the corners can be done all the way forward on the top of the rear of the wing, and the full length of the bottom, fairing it out at the plywood where the landing gear is mounted. The corners at the top front forward fuselage hatch may be rounded as well. Spot glue the hatch in place, round off the top and then cut the hatch away when finished.

Since there will be many different engine installations suitable to the model, no specific mounting holes are shown. Drill them to fit the engine and bolt using 3-48 or 4-40 bolts and blind nuts.

The landing gear used was a Hallco No. B105-4; a Top Flite Tauri/Headmaster wire landing gear can be used with a little mounting modification. These landing gears are available in most hobby shops.

Another thing you might wonder about is the servo linkage to the control surfaces. NyRods are used due to the lack of sufficient space and, when installed per instructions, work just fine.

The wing is a modified Tauri wing or, to be more exact, a Headmaster wing. Ailerons have been added and are inset. There is no dihedral which makes the construction easier twist free by being able to build on a straight flat surface. A dowel rod glued in at the leading



WORLD ENGINES

INCORPORATED
8960 ROSSASH AVE.
CINCINNATI, OHIO 45236

SUPPORT 
AEROSPACE EDUCATION

edge and nylon bolts used at the trailing edge hold the wing to the fuselage instead of the customary rubber band method of yesteryear. The added ailerons and absence of dihedral give more control making inverted flight easier and rolls smoother.

The fin, rudder, stabilizer, and elevator are constructed of 3/16 sheet balsa. This construction has proven very sturdy and simple. Make slots for the hinges in the fin and stabilizer trailing edges, and the leading edges of the rudder and elevator. The hinges are glued into the slots after the covering is applied. The same hinge technique is used in applying the ailerons to the wing. The fin is butt glued to the top of the fuselage, but before gluing, be sure the bottom of the fin fits snugly to the top of the fuselage, then add the 3/16 inch square fillets before gluing the fin in place. This makes it easier to shape the fillet as shown in section A-A.

When it comes to covering, it's entirely up to you. There are so many to choose from and each modeler seems to have his own choice. As for me, I have become a booster of MonoKote, using MonoKote exclusively to cover my airplanes for the last five years. MonoKote



Sid Axelrod admires the flat olive green WW I MonoKoted Snoopy. Where's the Red Baron?

is the quickest possible way to get an airplane finished and flying. Follow the instructions supplied with the MonoKote and you can't go wrong. The lack of compound curves will make this an ideal model to cover with MonoKote if you have never used this fantastic covering material before. Epoxy glue is used to seal the edges of the MonoKote in the engine well area. This area may be colored to match the covering. MonoKote trim sheets or MonoKote markings may be added to dress up the finish. A clear polyurethane varnish may be used to seal the edges of the sticky type trimming. If decals are used, allow them to dry thoroughly before sealing the edges.

The prototype, as shown on the plans, has a Kraft proportional control system installed. The all-up weight of the prototype, with a Max 19 in the nose, is three and a quarter pounds. The first few test flights proved out the value of proportional control. After taxiing around a bit to gain the feel of the controls and the ground handling, the power was advanced and the Snoopy Trainer went down the runway. With a slight amount of up elevator the flight (fright) was under way. Great! The model was out of trim and the transmitter trim levers could not overcome the amount of adjustment needed, the flight had to be concluded with the

NEW PILOT ARTF'S



GULL \$39.95

This sharp looking aircraft is designed to fly on elevator, rudder, and motor. It is a relatively large 3 channel airplane, 52 1/2" span. The manufacturer recommends a 20 but would probably fly on a 35 O.K. Nice vacuum formed fuselage, balsa elevator, molded foam wing with solid dihedral brace. Model also includes steerable nosewheel. A little larger than the Pilot Cherokee and Olympia. Worth the additional \$5.00.



MINNOW FORMULA I \$69.98

This model features the same type of vacuum formed fuselage and foam wing construction used in the popular Pilot Cavalier. The wing span 49.6". Length 39.37" (1 meter). Wing area 461 sq. in. Engine .4 cu. in. Weight approximately 5 lbs. This almost ready to fly pylon racer with racing lines, wheel pants, should make active pylon racing possible for the modeler too busy to build. This is particularly important in this rugged event.



PHANTOM \$18.95

The Phantom is an almost ready to fly U/Control model constructed of vacuum ABS plastic and wood. A very striking looking sidewinder. Wing span 25". Length 25". Wing area 192 Sq. in. Recommended engine 15 to 19. Flying weight approximately 1.35 lbs. Here is a chance for some U/Control flyers to enjoy the advantages of an A.R.F. package.



BEAT-X \$13.98

This is a U/Control combat trainer for a 20 engine. Wing span 30". It is a composite wood and vacuum formed aircraft. Even the name is a ringer.



STOL \$4.95
71" SPAN R/C

This glider is the Pilot Thermal's little brother. Foam wings. Vacuum formed fuselage with a plywood pod. Manufacturer recommends an .06 engine. .049 engine would probably work well.

SERVICE EXPERTS

ARIZONA

R/C Engineering
Jerry Behrens
P.O. Box 1451
Scottsdale, Ariz. 85252
Phone 602-949-5100

CALIFORNIA

Hobby Center
Electronics Dept., G. E. Lyman
861 Marsh St.
San Luis Obispo, Calif. 92107
Phone 805-543-3942
We sell and repair all types of major R/C Systems

COLORADO

Hood Electronics & Hobbies
5302 Howell St.
Arvada, Colorado 80002
Sales Installation
and repair of all makes of R/C Equipment
Phone 303-278-2079

FLORIDA

E. H. Bryant R/C
Box 416
Punta Gorda, Fla. 33950
We service all types of R/C gear—also build radio kits to your spec's.
Hobby Center
12600 N. W. 7th Ave.
Miami, Fla. 33168
Phone 305-681-4441
The Hobby House, Inc.
397 Hwy. 17-92
Casselberry, Fla. 32707

GEORGIA

Hobby Distributors
4 Avondale Road
Avondale Estates, Ga. 30002

ILLINOIS

Stanton Hobby Shop
4734 Milwaukee
Chicago, Ill. 60630
Controlonics
Karr Mfg. Div.
Box 32
Thomasboro, Ill. 61878
Radio Control Central
Box 56122
Chicago, Ill. 60655
Phone 312-545-9815

LOUISIANA

Mercury Hobbies, Inc.
573 Wickfield Drive
New Orleans, La. 70122

MICHIGAN

Walt Glemser
6829 Shenandoah Ave.
Allen Park, Mich. 48101
Phone 381-5708
1st Class Comm. License
For Legal Transmitter
Repair and Freq.
Verification/System
alignment

MINNESOTA

Al Schwartz
2787 Fernwood
St. Paul, Minn. 55113
Exclusively World Engines

MISSOURI

C.W. Reed
5408 Woodson Road
Raytown, Mo. 64133
Contact Charley for quote
on Blue Max Systems
Superior and OS
Max Engines

NEW HAMPSHIRE

Dembros Hobbies Inc.
58 Lake St.
Nashua, N.H. 03060
Low low prices on
R/C equipment plus
fast repair service

NEW JERSEY

J. A. Deneke
526 Doremus Avenue
Glen Rock, N.J. 07452
For same day service ship
entire system with fully
charged batteries.

R/J Control Systems
P.O. Box 280
Denville, New Jersey 07834
Tel. 201-527-7070

NEW YORK

Jerry Behrens
615 Monroe Blvd.
Long Beach, N.Y. 11561
Phone: 516-432-1874

NORTH CAROLINA

Triangle Technical Products
600 Glenwood Ave.
Raleigh, North Carolina 27603
Phone 919-853-1131

OHIO

Country R/C
12450 Amity Rd.
Brookville, O. 45309
4 miles S. of Interstate 70
We repair most
R/C equipment
Gerald L. Pelters, prop.
Town & Country Hobbyland
55 Country Road
Columbus, O. 43213
Neaf's Hobby & Sport Shop
4409 Mahoning Ave.
Warren, Ohio 44483

OKLAHOMA

Tulsa R/C
1241 S. 105 E. Ave.
Tulsa, Oklahoma 74128
Phone 836-5425
R/C Equipment Sales
FAST Service—
Mail or Direct

OREGON

Strictly R/C
11841 SW 23rd Avenue
Portland, Oregon 97219

SOUTH CAROLINA

S & R Hobby Crafts
Electronic Service Dept.
61 Constellation Drive
Charleston Heights
South Carolina 29405
Fast expert R/C service
at reasonable prices.

TENNESSEE

Aerotonics
109 Chatham Lane
Oak Ridge, Tenn. 37830
R/C equipment—Service—
repair—Trade R/C
problems? Free
consultation and advice for
beginners or experts.

TEXAS

Wilson's Hobby Shop
2705 West Beauregard
San Angelo, Texas 76901
Custom built units by
Eldon Wilson. All parts,
stocked for MAN, Blue
Max. Complete repair
for all W.E. radios

VIRGINIA

Radio Electronic Model Shop
800 National Aven.
Winchester, Va. 22601
Phone 703-667-1730
Complete sales and service
Kits and equipment

SOUTH AFRICA

Sean McCullagh
18 Avon Road
Deer River
Capetown, South Africa

OUR R/C LINE INCLUDES:



WORLD'S EXPERT'S SERIES 6ch \$460



MK II BLUE MAX SYSTEMS 6ch \$340



NEW PYLON MIGIT 5ch \$285

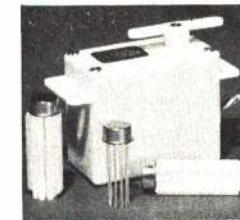

S-5 ASSEM 35.00
S-5 SEMI 24.98
RETRACT 40.00

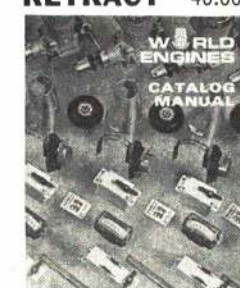

CATALOG
Price - \$1.00



WORLD ENGINES

INCORPORATED
8960 ROSSASH AVE.
CINCINNATI, OHIO 45236

Join the pro's and use ... AMBROID ADHESIVES



Ambroid Regular Cement
The model builder's standby
For all woods, leather, canvas
metal, fabrics - waterproof, and
hot fuel proof.

**Ambroid Extra Fast
Dry Cement.**
For on-the-spot repairs, it
dries very quickly and is strong.



**Ambroid Se-Cur-It
Resin Glue.**
The super strength glue
for all styrofoam, ceramics,
cloth, paper and leather.
hot fuel proof.

Available at your hobby dealer!

AMBROID COMPANY
612 Montello Street
Brockton, Massachusetts 02403

KRAK-A-LONG

A VERY STABLE DESIGN WHICH PERFORMS
WELL ON CALM OR ROUGH WATER.

\$39.95 ppd.



FOR SPEED & STEERING
ENGINES UP TO .40
LENGTH 28" BEAM 10 1/2"



INCLUDED IN KIT:
Fibre Glass Hull by Johnny Johnson
Die-cut Superstructure,
Decking etc by Solarbo
Plan & Instructions
ACCESSORY PACK:
Engine Mounts, Rudder Assembly
Prop-Shaft Assembly
R/C Tiller Arm, Ball Coupling

\$11.95

DEALERS JOBBERS
Require Discount

XL-ENT PRODUCTS, BOX 347, PORT JEFFERSON, N.Y. 11777

"FULL HOUSE PLUS THREE"



**Great New Single
or Dual Stick Designs**

Eight independent channels in a package no bigger than conventional full-house transmitters. Choose either single or dual-stick control in 27, 53 and 72 MHz operation - with adjacent frequencies at no extra cost. Both transmitters have a two-position switch for landing gear, finger adjust tabs for auxiliary channels; trainer link jacks and "buddy button"; external charging jack for simultaneous charging of transmitter and receiver batteries; eight range controls for adjusting servo travel. You can order your Heathkit Eight-Channel System with any combination of four GDA-405-4 Miniature Servos or GDA-505-4 Sub-Miniature Servos. With receiver, battery pack and four Miniature Servos, airborne weight is 13.3 oz. Substituting four Sub-Miniatures, shown in illustration, brings the weight down to 11.3 oz. If you want eight-channel flexibility, the GD-405 systems, at build-it-yourself Heathkit prices, are the only way to fly.

Kit GDA-405-S, Single Stick Transmitter only, 4 lbs. \$139.95*
Kit GDA-405-D, Dual Stick Transmitter only, 5 lbs. \$119.95*
Kit GDA-405-2, 8-Channel Receiver only, 1 lb. 54.95*
Kit GDA-405-3, Receiver Battery Pack only, 1 lb. 9.95*
Kit GDA-405-4, one Miniature Servo only, 1 lb. 24.95*
Kit GDA-505-4, one Sub-Miniature Servo only, 1 lb. 24.95*

SAVE ON A SINGLE STICK SYSTEM: consisting of transmitter, receiver, battery pack and any four servos. Batteries included. List model numbers separately.
Special System Price 269.95*

SAVE ON A DUAL STICK SYSTEM: consisting of transmitter, receiver, battery pack and any four servos. Batteries included. List model numbers separately.
Special System Price 249.95*



The FREE
Heathkit
Catalog has
over 350
fun to
build kits.
Order
yours
today

HEATH COMPANY, Dept. 80-12
Benton Harbor, Michigan 49022

Please send FREE Heathkit Catalog.
 Enclosed is \$ _____, plus shipping.

Please send model(s) _____

Name _____

Address _____

City _____ State _____ Zip _____

Prices & specifications subject to change without notice.

*Mail order prices; F.O.B. factory. GX-261

HEATHKIT
Schlumberger

flying sticks about one third the way over to maintain straight and level flight. An investigation proved the push-rod clevises had not been adjusted properly. After the proper adjustments had been made, the next flight had proved all the effort was not for naught and a good performing airplane for the weekend sport flyer was born.

The Snoopy Trainer is capable of flying with a Cox 09 or a Max 10 if kept on the light side. A 15 or a 19 engine will make the Snoopy Trainer perform quite well for you. weekenders. Eat your heart out Red.

QUICKY 500

(Continued from page 38)

1/16 and two from 1/2. This is best done by stacking the wood between two metal templates. Cut bottom trailing edge sheeting to 1-7/8 wide and glue on 1/8 x 1/4 balsa trailing edge. Cut bottom leading edge sheet slightly oversize and glue on 1/8 x 1/4 spruce spar. While these are drying, strip a sheet of soft 1/16 to 2-15/16 wide and cut all webbing (grain vertical). When dry, pin the trailing edge sheet down to a flat board. The board must be flat as any built-in warps are there to stay. Pin rear of leading edge sheet down and block up front 1/8. Now starting with center rib, glue it to rear sheet and front spar only (See Step 1). Cut webs to fit plan and place alternately, i.e. web, rib, web, rib, etc. After the second 1/16 rib is in place, the remaining webbing will all be 2-15/16 long. Be sure that webs are of correct height to fit top spar and top rear sheet. This is a very important joint and contributes a great deal to torsional rigidity. Also note that front webbing is located near front of spar.

Next, as shown in Step 2, block up front of leading edge sheeting to fit ribs and trial fit leading edge. The leading edge is cut from 1/4 medium sheet balsa. If a table saw is available set it at 20° to obtain the correct angle for leading edge. If you do not have access to a saw, then cut and sand leading edge to shape shown on plans. Now remove blocks under leading edge sheeting temporarily and put glue on 1/2 inch rib only, then re-block. It's then a simple matter to glue in leading edge and fillet glue 1/16 ribs to sheeting. Fill in between 1/2 inch ribs and first 1/16 ribs at rear solid with balsa. Install 1/16 ply behind leading edge to support dowels. Then glue in top spruce spar and top trailing edge sheeting (See Step 3). After top spar is dry, use white glue on spar and ribs only, then lay top sheeting on, use 1/8 x 1/4 spruce temporarily at rear of sheet and clamp with clothespins. The tapered end on clothespins must be cut off square. Use regular model cement on leading edge, as it sands easy, and pin down sheeting through a piece of 1/4 square balsa (this helps hold sheeting flat). When this is dry, the wing can be removed from board for adding cap strips and block tips. Now saw or sand correct dihedral angle in center ribs. Glue the two halves together with white glue, sheet center section, sand all over and epoxy a piece of 3" wide fiberglass cloth to the center section. Except

✓ CHECK THIS DEAL

MCE CAR ~~\$89.96~~
 VECO .19 Sidewinder ~~30.00~~
 KRAFT 2 Channel Radio ~~119.95~~
 (Dry Batteries not included)
 HELD
 OVER!! **OUR PRICE \$159.95**
~~\$239.90~~

Include \$5.00 for postage & handling. SALE ENDS NOV. 30th, 1972



MCE CAR
 was **Special**
\$89.95 \$29.95*

Car completely assembled. Only radio and engine installation required. Hi-impact plastic body. Exact scale. Mag wheels, coil springs.

Include \$5.00 for postage & handling.

HEADQUARTERS FOR 1/12 SCALE JEROBEE CARS & PARTS

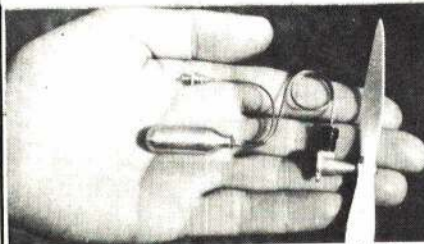

BROWN CO₂
\$24.95

- E-Z Starting
- Variable Power Output
- Displacement .005 cu. in.
- Complete with Williams Prop
- Weighs less than 1/4 oz.
- Add \$1.00 postage

CO₂ charger necessary
 New Style Charger \$3.95
 \$1.00 postage

Send stamped, addressed envelope for price list and inquiries.

New York Residents Include Tax

LARRY'S HOBBY SUPPLIES

3018 Jericho Turnpike East Northport, L.I. N.Y. 11731
 Phone (516) 864-7166—Dept. M

Don't forget to scan through our long list of plans available through **SUDDEN SERVICE PLANS** on page 84 and 85. Send in for new plans today!

SUPPORT
AEROSPACE EDUCATION

We're worth traveling for!

NEW YORK

And you'll see why when you see our fabulous selection of leading hobby merchandise, all at low, low discount prices! We carry the top name brands in U/C and R/C equipment for your buying convenience. You'll be glad you traveled... when you see what's in store for you at our "one-stop" shopping centers for hobby merchandise. Centrally located for New York, New Jersey and Pennsylvania residents.

TINY TOTS
 OUR NEWEST STORE (OAKHURST, N.J.)

OPENING FALL 1972 (TOMS RIVER, N.J.)

U. S. ROUTE 22, GREENBROOK, N.J. PHONE (201) 968-0440
 U. S. ROUTE 35, MIDDLEBROOK SHOPPING CENTER, OAKHURST, N.J. PHONE (201) 493-2022

Both stores open daily 'til 9:30 - Sundays 10 to 5

TINY TOTS

PLAY & RECREATION ITEMS FOR EVERYONE

JACK STAFFORD MODELS

Super Minnow Wins
4th NATS in a Row!

12111 Beatrice · Culver City, CA 90230



50" Span Formula 1 Super Minnow
Winner 69, 70, 71 & 72 NATS
Super Minnow \$49.95



Messenger 44" SPAN 40-60 ENGINE
FULLY AEROBATIC \$45.95



Chipmunk 59" SPAN 40-60 ENGINE
FOAM WING \$49.95



Comanche 72" SPAN 56-65 ENGINE
ALL Balsa MOLDED COWL \$49.95



Aircoupe 63" SPAN 35-60 ENGINE
SCALE TRAINER \$49.95



Super Midget 48" SPAN NEW
FORMULA I \$49.95



Mustang WITH FIXED GEAR \$49.95
WITH RETRACTABLE GEAR \$54.95



40-60 Engines Weekender
Prefab Basic Trainer \$49.95



38 Span 15 Engines Mustang-QM
Quarter Midget \$34.95

Send stamp for new catalog.

for ailerons, the wing is complete. This whole procedure sounds a little complicated but it's fast and easy.

The fuselage is super simple with only a couple of points worth mentioning. Cut sides from medium weight 3/16 balsa and glue on two 1/8 x 1/4 vertical stiffeners towards rear. Glue in formers "C," "D" and "E" with epoxy, making sure everything is square. When dry, install former "B" and glue side together in rear after tapering slightly and install former "F." The top may now be sheeted with 1/8 balsa. Do not install former "A" until all fuselage sheeting, including hatch ring, is complete. It works out best to leave all bottom sheeting off until after stabilizers are attached, servos temporarily installed, control horns located and pushrods completed. Hard 1/4 square balsa pushrods are recommended. Check incidence, if correct, make a long drill out of 1/4 inch brass tubing saw-toothed at one end with a triangular file. Hold wing in place on fuselage and drill holes for dowels in wing using holes in former "C" as a guide. Next drill holes in rear of wing for nylon bolts (use tap drill), add 1/16 plywood discs to wing and re-drill wing with body drill. Install 1/4 dowels in wing, tap hardwood fuselage block and re-install wing on fuselage. If everything fits, you can sheet bottom of fuselage. If possible, use beechwood for all hardwood blocks. It is strong, holds threads well and is resistant to splitting. A little fiberglass cloth around nose, running back on sides and bottom an inch or so, does wonders for keeping the front end together. Be sure to put 1/4 diagonal fillets all around inside of nose section, they help make it rigid.

No radio or servo installation is shown due to the great variety now being used, so this is left up to the builder. The "Quicky 500" was drawn up to use the smaller radios now in use. If you have one of the older sets, you may want to build the fuselage slightly wider, check before starting construction.

I show a long Kraft-Hayes motor mount on plans. Use the long mount even if you plan to fly with a front intake engine—balance you know. I prefer this mount because engine mounting screws never come loose. I also show Kraft-Hayes slim-line wheels as these are streamlined and easy to install.

Try to pick lighter weight wood for building this model. If possible, use extra light quarter sawed wood for the stabilizers. One of the reasons the "Quicky 500" can turn times close to Formula One models is its average weight of 3½ to 4¼ lb. This light weight allows the model to accelerate fast off the line, out of the turns and helps make up for lack of top speed down the straight. Strength is not a problem when using light wood, this little ship is tough. The only exception to the light wood philosophy is the 1 x 1/4 ailerons, which should be hard and stringy.

For covering, take your choice. "Quicks" have been covered with all types of material. The wing is designed with enough strength to allow the use of

READY-TO-FLY FLOATS

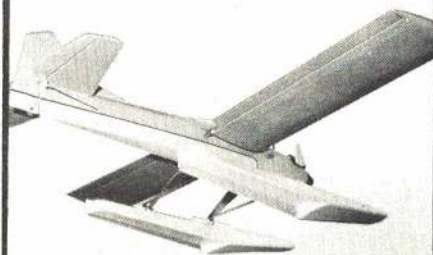

Three years in designing and testing. Fully assembled—not a kit—ready to be mounted on your model. Displacement 8 pounds plus. Guaranteed water performance for 35 powered planes and up. Beautifully tapered high step for minimum drag—both on water and in the air. **Virtually indestructible in normal use. Complete with hardware.** 33" size available **now**—more sizes coming.

33" Pair \$19.95, complete

GEE BEE line 

143 E. MAIN STREET
CHICOPEE, MASSACHUSETTS 01020

HOBBY HELPERS FULL SIZE PLANS

Group Plan 465 3 oz. . 60 cents

Jimmie Mattern's record-breaking Lockheed Vega—modeled as control line beauty by Walter Musciano. Spans 50"; length 34"; for .45-size or similar power.

Simplified control line autogiro—designed by Ole Dan Nielsen. Rotor diameter 34"; length 37"; takes .45 to .65 size engine with motor control.

Group Plan 966 6 oz. \$1.10

Lockheed Lightning P-38. Semi-scale stunt control-line model by Lew McFarland, uses twin .19's with throttle control for shooting landings.

Thorp Tiger. Famous home-built aircraft in radio control model form by Jess Kriesser. Takes a .35 engine.

Group Plan #953C 1 oz. 45¢

Focke-Wulf FW 190 German World War II control line flying scale fighter model by Walter Musciano. 3/4" to 1" scale; takes engine from .14 to .29 cu. in.

A/2 Viking Nordic Towline Glider by British Champ Bill Farrance. These are HALF-SIZE plans with full size ribs and cross sections.

Group Plan #166 6 oz. \$1.10

"Interceptor Five" by Harold deBolt. Latest in famous designer's series of outstanding R/C Multi-Class planes. Spans 67½ inches; 50 inches long; uses .61 size engine.

For Special Handling of Plans only	8¢ per oz. 1st Class 11¢ per oz. AirMail United States and Possessions only	Latest Catalog send 15¢ to cover handling
------------------------------------	---	---

HOBBY HELPERS
1543 STILLWELL AVE. · BRONX, N.Y. 10461

BACHMANN

MINI-PLANES

THE WORLD'S LARGEST AIR FORCE

ADDS 6 MORE

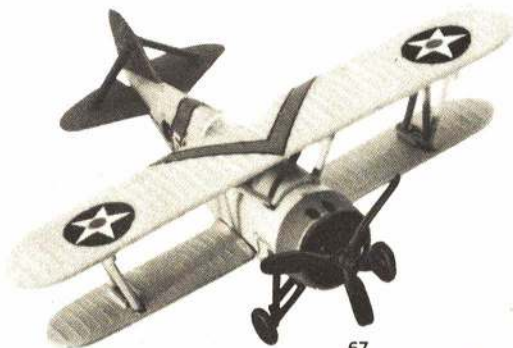

67
GRUMMAN F3F



65
B-58 HUSTLER



70
CURTIS HELLDIVER

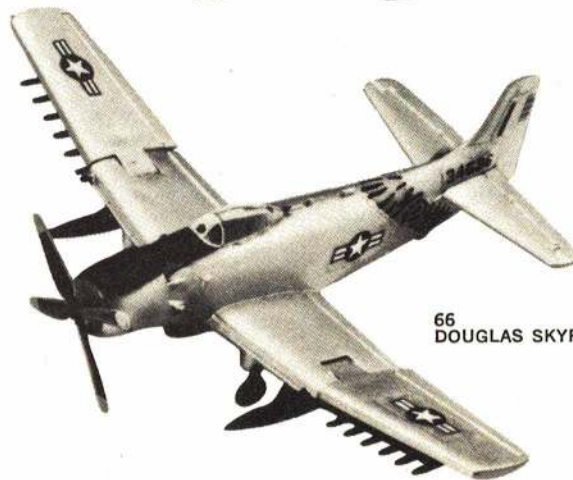

66
DOUGLAS SKYRAIDER

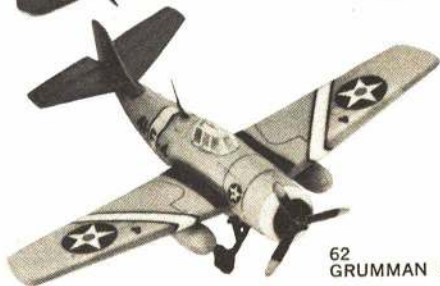

62
GRUMMAN F4F WILDCAT

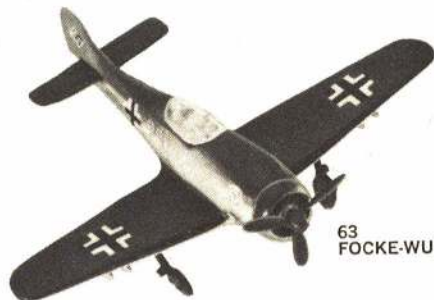

63
FOCKE-WULF 190

- FULLY ASSEMBLED
- MICRO DETAILING
- HAND DECORATED
- MOVING PARTS
- AUTHENTIC
- EXACT SCALE

79¢
each

BACHMANN

Quality Since 1833
PHILADELPHIA, PENNSYLVANIA 19124



Royal

SQUEEZED

THE POWER IN ..

.. AND CAME UP WITH AN
ELECTRIC FUEL PUMP
THAT FEATURES SELF-
CONTAINED POWER

Engineered with convenience in mind, the new Royal Fuel Pump features increased operating versatility and decreased physical size.

Two Pencells, which fit snugly into an attached battery compartment, supply enough power to fill or drain more than 5 gallons of fuel without battery replacement. If still greater capacity is desired, the battery compartment may be completely detached and a wet cell of 2 to 6 volts wired directly to the pump's power leads.

Portability is enhanced by a modern case design which features a built-in bracket allowing the pump to be hung from the side of most conventional fuel containers.

Add it up—a versatile pump for a lower price. Visit your local dealer, compare for yourself and insist on Royal!



ONLY
\$9.95

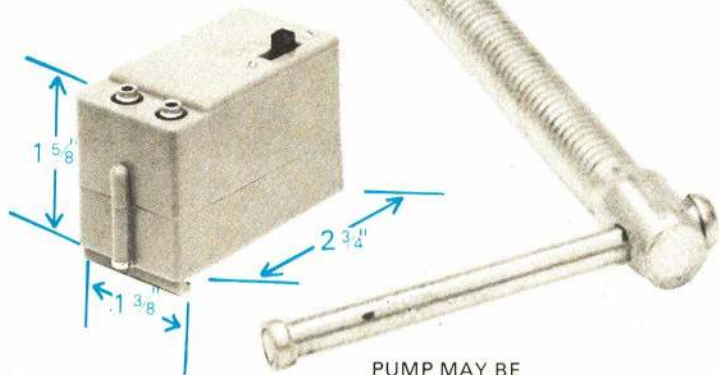

PUMP MAY BE
POWERED BY
TWO PENCILL
BATTERIES
(not included)



BUILT-IN HOOK
FOR HANGING
PUMP ON FUEL
CONTAINER

CASE MADE OF
MOLDED PLASTIC

AND AFTER FUELING . . . START YOUR ENGINE WITH THE NEW RMK STARTER HOLDER



DEALER
INQUIRIES
INVITED

**ROYAL PRODUCTS
CORPORATION**

6190 E. EVANS AVENUE,
DENVER, COLORADO 80222

\$1.49
ea.

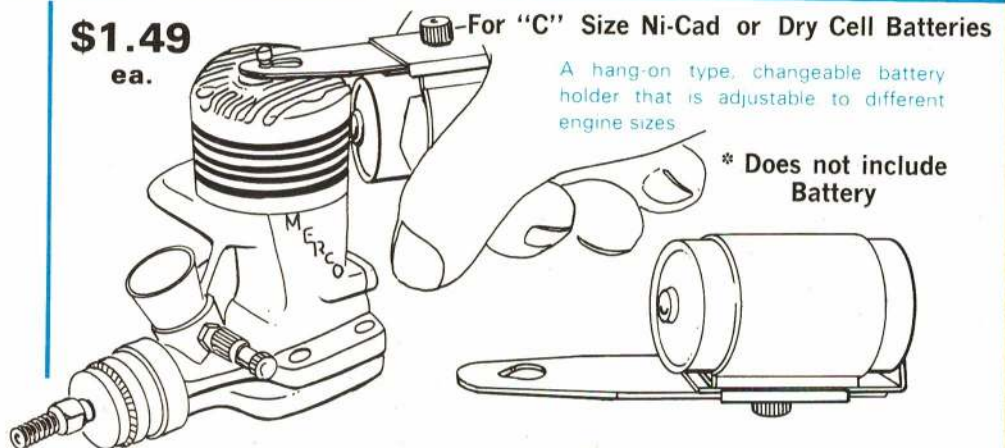

-For "C" Size Ni-Cad or Dry Cell Batteries

A hang-on type, changeable battery holder that is adjustable to different engine sizes

* Does not include
Battery

**NEW!
RETRACT ARM**

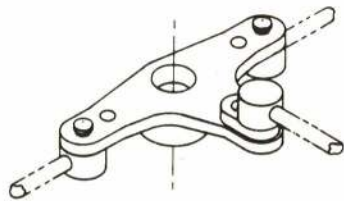

Furnished with special snap in push rod holders. Choice of 2 different throws.

Outer holes 1-1/16" throw.

Inner holes 13/16" throw.

Stk. #41 - for KPS-10 servo.
Stk. #42 - for World E. servo.

Price .98¢ each

See your dealer or order direct
add .25¢ for post. & handling

ROCKET CITY SPECIALTIES
103 Wholesale Ave., N.E.
Huntsville, Ala. 35811

STEINGRAEBER Ship Models

For the ship modeler Steingraeber makes over 20 different ship kits. Each is of rib and plank construction and the finest in fittings make the kits a joy to build and display. Included in the selection are:

- #1002 "Phoenix" Tugboat
for RC 26.95
- #1003 Steam Sailer
"Sirius" 45.95
- #1005 Modern Cruiser
"Le Corse" 47.95
- #1010 Fishing Trawler,
for RC 62.95
- #1050 Fair American 49.95
- #1110 Slaver "Agilis" 45.95

Send for our catalogs—

- Steingraeber Catalog
& Handbook 2.00
- Constructo Color Ship Catalog 3.00
- Boyd Models New #10 Catalog 1.00
- "Ship Models and How to
Build Them," Hardcover 5.95

BOYD MODELS
810 East 14th St. Los Angeles, Calif. 90021

FAMOUS CLEVELAND DESIGNS

World's Most Highly Priced Authentic Plans
**REMEMBER THE OLD C-D BEAUTIES?
C-D 1 1/2" SCALE GAS SIZE PLANS**

Those "Terrific" Old C-D's Now in 1 1/2" Scale. Prices
INCLUDE Patterns. Are Blow-Ups of 1/2" Jobs.

- G1 Great Lakes 2T1A \$9. G52 Mr. Mulligan \$11.
- G138 Spad XIII \$9. G60 Boeing P26-A \$11.
- G15 Fokker D7 \$12. G64 Beech. C-17-B \$12.
- G188 Howard's Pete \$12. G72 Turner-Laird \$9.
- G218 C. Hawk P6-E \$12. G73 Superm. Spiffire \$12.
- G428 Howard's Ika \$12. G74 Messer. ME-109 \$12.
- G48 Turner's W-W \$9. G75 Grum. Skyrocket \$12.
- G49 Hawk F11C-2 \$12. G83 Grum. Wildcat \$12.
- G51 Comet Racer \$12. G139U Sopwith Pup \$8.



MINIATURE TWIN-MOTOR C-D PLANS

COMPLETE with Patterns in 1/2" Scale (Take One-Half of 1/2" Scale Catalog Sizes) Add 10% to ALL Plan Ords.
M35 Boeing 247 \$8. M105 Was. Whirlwind \$6.
M45 Bomber B-10 \$8. M115 D. Havoc A-20 \$9.
M51 Comet Racer \$37. M125 Mitchell B-25 \$10.
M75 Skyrocket XF5F-1 \$6. M135 Marauder B-26 \$12.
M85 Lightning P-38 \$7. M145 DH Mosquito \$8.
M95 Hudson Bomb. \$9. M155 Bl. Widow P-41 \$12.
M100 Boeing B-17 \$13. M165 Douglas DC-3 \$14.
SF 1/2" Scale Fans: You May Now Order P.S. Pattern
Supplements for All Multi-Motor C-D Jobs. Prices
Same As Printwood. Many More New Jobs.

FOR LATEST PICTORIAL CATALOG SUBSCRIPTION
JUST SEND NAME, ADDRESS AND INCLUDE \$1 BILL

CLEVELAND MODEL & SUPPLY CO.
10307B Detroit Since 1919 Cleveland, Ohio 44102

Once the model is trimmed out, take it to an open spot. Grasping Thing at the back, throw it straight up, pointy end first. Keep doing this until you can make it fly. Now look at all the people staring at you. Don't you feel ridiculous? Thing never flies well in front of a crowd but always gives spectacular flights when the owner is by himself—a defect that I have noticed in most other designs. Have fun!!

RC SOARING

(Continued from page 45)

enterprise, and of course there will always be some which remain secrets.

These are some of the new designs: Steve Lilly's Piece of Cake; Jim Porter and Ed Harris' Shriek; Dough Munn's Intrepid; Tom Kelly's Big Windy; Roger Scher's 888; Buck Zehr's Zehrgutt; and Jerry Mrlik's Stratus. Two unique ideas in control linkage arrangements were used by Chet Lanzo and Tom Kelly. Lanzo's famous Nordic floater had a spring-loaded one-piece elevator rotating on the leading edge with string acting as the control rod to the servo. Utilizing the parallelogram theory, Tom Kelly designed a simple mechanism to actuate ailerons. My "Where the Action Is" column will feature the Kelly-gram with a drawing showing plug-in wings with butt connections for damage-free break-aways, bellcranks and Nyrod linkage.

Monday and Tuesday activities followed the same pace established on Sunday. With heavy rains forecast for late Monday afternoon, we adjourned early, giving us a much needed rest period before hangar flying that evening. Con-

The Nats awards display included 29 trophies with the Grand Champion prize of a Schwinn bicycle donated by the manufacturer.



FAMOUS ROTARY ENGINE

\$1.75
plus
25¢
postage

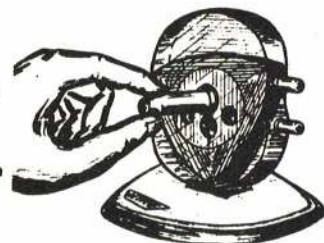

SEE HOW THE ENGINE OF THE FUTURE WORKS WITH THIS ATTRACTIVE SEE-THRU MODEL, KIT AND TECHNICAL DATA.

Send \$2.00 to: VETCO, dept. A
P.O. Box 23, New Almaden, Calif. 95042

testants represented every major soaring organization—East Coast Soaring Society (ECSS), League of Silent Flight (LSF), Mid-America Soaring Society (MASS), Greater Detroit Soaring and Hiking Society (GDS&HS), South Bay Soaring Society (SBSS), Harbor Slope Soaring Society (HSSS), and the Nats host, S.O.A.R.

During the three-day competition, several celebrities visited the Soaring Nats: radio announcer Paul Harvey; AMA President, John Clemens; AMA's Executive Director John Worth; Dr. Walt Good; and Chet Lanzo.

Various demonstrations were given showing the old and new manpower techniques. S.O.A.R.'s Olympian runner, Jack Hiner, demonstrated the age-old art of hand towing which is no match for today's modern machinery when it comes to altitude. At the same time, a real step saver was demonstrated by designer Bill Wargo; he made three consecutive glider tows featuring a manually operated retrieval system for the towline. Upon release from the tow hook, the towline is returned by a retrieval line in less than 30 sec. This new winch will do much to speed up the launch cycles and increase the number of rounds at future meets. The Best Technical Achievement Award was presented to Bill for his endeavors.

The implementation of the following two operational procedures proved to be highly successful in running the meet. Each launching device was constantly attended by a Winchmaster who monitored winch operation and provided launching assistance if desired.

Ready for the journey across the field is one of four special work horses that shared in making the 591 tows.

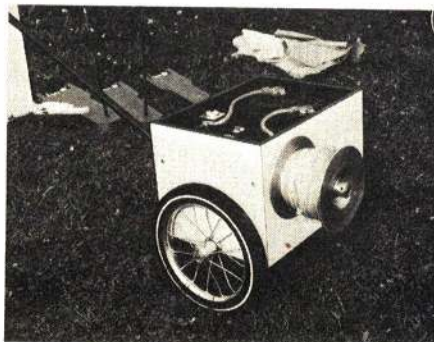



MIDWEST PRODUCTS CO.
Hobart, Indiana

Norm Page
A Top Winner U.S. Nationals
with Mach I



Champions choose MIDWEST balsa

You'll see why the moment you compare Micro Cut Balsa to any other Product you're now using . . . It's lighter, it's stronger . . . it's more pliable. Triple inspected for uniform quality & smooth as silk finishes . . . Models seem to go together faster, easier with Micro Cut Balsa.

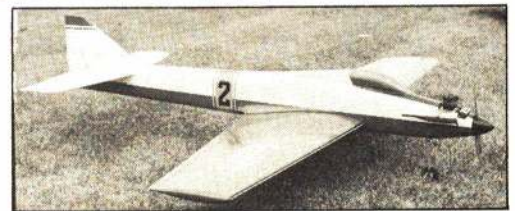

MACH I IS BEING KITTED BY MIDWEST.

WRITE FOR OUR CATALOG OF COMPLETE KITS AND ACCESSORIES.
MAIL 25¢ FOR POSTAGE & HANDLING

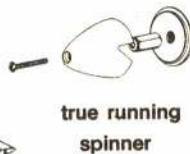

NEW NITRO PLUS ADDITIVE



NEW NITRO X RACING FORMULA



MIDWEST PRODUCTS
400 SOUTH INDIANA ST.,
HOBART, INDIANA 46342



NAME _____
ADDRESS _____
CITY, STATE _____ ZIP _____

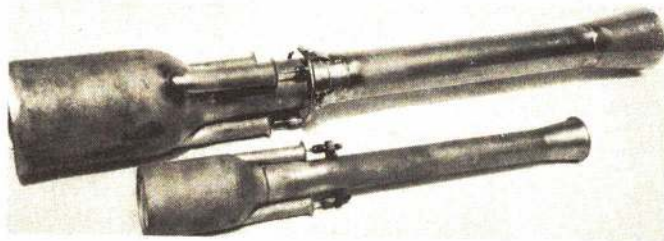

Engine Model J5-300
 Length 35 inches
 Diameter 5 inches
 Max. Thrust Over 10 lbs.
 Price \$98.00

Engine Model J3-200
 Length 21 inches
 Diameter 3 inches
 Max. Thrust Over 3 pounds
 Price \$56.95

Small jet engines for Model Aircraft... Boats... Race Cars... Experimenters.
 Operates on propane fuel. No rotating or vibrating parts. Throttleable between 50% and 100% power.

Manufactured by
THERMO-JET
 BOX 1528 · KERRVILLE, TEXAS 78028

THERMO-JET

With the impound area located between the launch and landing areas all within close proximity to each other, frequency control pins were kept in maximum usage. A lot of hard work including many long hours of preparation were contributed by S.O.A.R. in hosting the '72 Nats. For this devotion, the Silent Order of Aeromodeling by Radio should be eulogized. Departing the spacious fields of Miller Meadow, contestants take with them new ideas for that super ship, memories of the festivities, thoughts on ways to improve their own skill and, most important, new friendships developed at the Nats. Thermals!

Final Overall Standings

1st Place: R. Vandierdonck (Michigan), 4722 pts., Open; 2nd Place: J. Donelson (California), 4681 pts., Standard; 3rd Place: O. Heithecker (Michigan), 4640 pts., Open.

Team Standings

1st Place: Greater Detroit Soaring and Hiking Society (Heithecker/Pell/Vandierdonck), 12,530 pts.; 2nd Place: South Bay Soaring Society from San Jose, California (Christian/Horton/Walters), 10,351 pts.; 3rd Place: Harbor Slope Soaring Society from Los Angeles (M. Smith/R. Smith/Thacker), 10,287 pts.

HEINKEL'S BIPLANE

(Continued from page 33)

seat. The He-51 had been flying since the summer of 1933, and by late 1935 there were nearly 200 of them—a lot of airplanes in those days.

The origins of the He-51 can be traced back to the late 1920s and the HD 37, a single-seat Ernst Heinkel biplane fighter. It was followed by the HD 38, the HD 43 and the He-49. This last airplane flew in late 1932 and led directly to the He-51, which was structurally and dimensionally similar, but differed in many refinements. In fact, the fourth He-49 prototype became the first He-51 prototype, flying initially in the summer of 1933.

Before that year had ended, the German government had ordered production of the first group of fighters, since tests of the He-51a had been considered so successful. The first of these had a tail skid in place of a wheel, long exhaust stacks to keep the fumes away from the pilot, and no streamlined headrest. Armament was limited to a pair of .30 cal. machine guns mounted just in front of the windshield. Construction was pretty much in line with practices that had been common in 1918: wings were wood covered with fabric, fuselage and tail were welded steel tubing covered with fabric.

The first airplanes reached a test-and-operations squadron in July 1934, and were quickly accepted, even though many of the pilots objected to the He-51's lack of maneuverability when compared with the Arado 65 they had been flying. Still, the Heinkel biplane went right into production, with the first He-51A-1 being accepted by the Luftwaffe in April, 1935. By the end of

FLITE BOXES BY INKY

AT LAST A GOOD SIZED ECONOMICAL BOX FOR RC-CL-FF



MODEL 50

APPROX. SIZE 8" x 12" x 20"
 LIGHT AND STURDY—30 MIN. ASSEMBLY
 PARTS MACHINED—READY TO ASSEMBLE
 KIT ONLY \$7.95 POSTPAID
 SEND CHECK OR M.O. TO
 INKY

10436 W. Rae Ave. - Milwaukee, Wisconsin 53225

PEANUT SCALE!

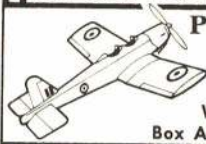

PLANS • WHEELS & SUPPLIES

Complete catalog 25c
 W. C. Hannan, Graphics
 Box A, Escondido, Ca. 92025

SPIN A WIN! FLY Tornado

Get MORE travel-from-torque!
 Every Grish-engineered
 TORNADO Propeller has true pitch...
 delivers MORE of your engine's power.



PROPELLERS

YELLOW NYLON

7.8	85¢	8.6	8.8	9.6	10.6	10.4
5.3	6.3	6.3	6.3	6.3	6.3	6.3
5.4	6.4	6.4	6.4	6.4	6.4	6.4
each	35¢	85¢	\$1	50¢	50¢	50¢
2 Blade Tractor	2 Blade Pusher	3 Blade Tractor	3 Blade Tractor	3 Blade Tractor	3 Blade Tractor	3 Blade Pusher
5.3 5.4 each	5.3 5.4	5.3 5.4	5.3 5.4	5.3 5.4	5.3 5.4	5.3 5.4
30¢	35¢	50¢	50¢	50¢	50¢	50¢
below in white, too	9.4 9.6 9.7 9.8	10.4 10.6 85¢	11.4 11.6 11.8 \$1	RC 12.4	12.5 12.6 \$1.50	

3-BLADE NYLON
 Metallic Aluminum Color

GRISH

ST. JOHN BROS.
 INDIANA 46373

European

CARD MODELS

PLANES, SHIPS, ARCHITECTURE; IN FULLY COLORED, THREE DIMENSIONAL, CUT OUT AND ASSEMBLE SCALE MODELS FROM PAPER. THESE DETAILED CONSTRUCTIONS SUPPLIED AS PRINTED SHEETS. CODED LINES, PLUS A "METHOD SHEET" IN ENGLISH, SUPPLEMENT FOREIGN LANGUAGE INSTRUCTIONS TO PROVIDE NECESSARY DIRECTIONS.

The JUMBOS
 7-1463 DORNIER DO-X (1:100) \$1.94
 7-1823 BOEING 747 (1:50) \$3.15

SIX MILITARY PLANES (FIVE TYPES)
 (1:50) \$4.08

special
 Large Transports (1:50)
 7-933 DC-7C 36" SPAN \$1.80 (\$3.30 Reg.)
 7-989 CONSTELLATION \$1.80 (\$3.30 Reg.)
 7-900 ELECTRA \$1.30 (\$2.30 Reg.)

#1204 SCHARNHORST 37" \$4.75
 #1203 LEIPZIG 27.8" \$3.10
 #1205 KARLSRUHE 26.4" \$3.10
 #1210 LUTZOW 30" \$2.75
 #1021 ONASSIS' CHRISTINA 15" \$1.25

(WATERLINE 1:250)



ONLY IN CARD

7-1893 \$4.25
 D-LZ 127 GRAF ZEPPELIN
 1:200 FOUR FEET LONG

Catalog \$.25 (Free With Order)

JOHN HATHAWAY
 410 W. 6th St/Box 1287
 San Pedro, Calif. 90731

Foreign Orders California Residents
 Postal Money Order or Bank Check, collectable in U.S. Funds without charge
 5% Sales Tax
 NO C.O.D.

SHIPPING CHARGE
 \$.35 (UNDER \$2.50)
 \$.50 (TO \$4.99)
 \$1.00 (TO \$9.99)
 \$1.35 (\$10.00 & OVER)
 *Calif. \$1.10

You Just Put Your Hands On A Winner!

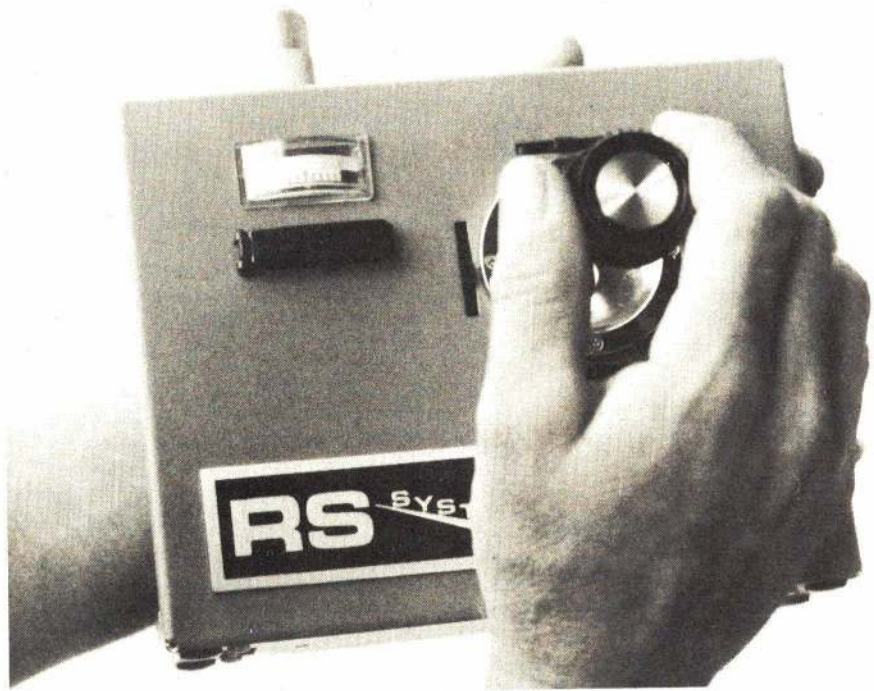

WRITE FOR A FREE
BROCHURE TO:

RS SYSTEMS 2407 S. BROADWAY
SANTA ANA, CA.
92707

Pilot Kits

Cessna Cardinal	Reg. \$34.98	Spl. \$27.98
Gull	Reg. \$34.95	Spl. \$31.95
Shell Fly B	Reg. \$49.98	Spl. \$35.69

Merobee



COMANDO CAR COMPLETE

Add Batteries & Gas
and Drive It Away!
Yes We Stock Parts
List \$115.00

SPL. \$87.96

Add \$10.00 and we will supply
Batteries and Test Drive the Car before shipping.

Field Box

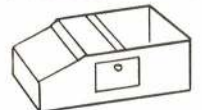

Completely Painted
\$34.95 Spl. \$29.95
Unpainted \$24.95
Spl. \$22.95

Kit \$18.98 - Spl. \$17.00



PAL-Z RC TRAINER

52 1/2" Span
Eng. 19 to 25
3 to 4 ch. Reg. \$28.95
Spl. \$24.95

ZENITH R.C.

Advance Trainer
52 1/2" Span Low-Wing, 19 to 35
Semi Symmetrical Wing

R/C
FALCON ♂
Reg. \$19.95 Spl. \$14.95



Christmas Unimat Special

Purchase Basic Unimat
Lathe \$169.50

**RECEIVE FREE
Special package**

retails for \$30.85

1 - Right hand tool holder
1 - Left hand tool holder
selection of tool kits -
& No. 1210 Milling table



(A HINGE
POINT WITH
A HORN)

4 Pkg.
Reg. \$3.16
Spl. \$2.25

Distributed by Indy R/C



(317) 846-0766

SULLIVAN REALISTIC LANDING GEAR

3 Gear Sets
GS-1 Reg. \$9.95 Spl. \$7.96
GS-2 Reg. \$9.99 Spl. \$7.96



FLEA FLI + 10

Eng. .19 to .30
Reg. \$24.95 Spl. \$17.95

NORTH - 10538 Jessup Blvd., Indianapolis, Indiana 46280 • SOUTH - 2747 Brill Road, Indianapolis, Indiana 46225

HOW TO ORDER: Send Check or Money Order for prompt delivery.
Please include ZIP CODE. Indiana residents add 2% Sales Tax.
Sorry, no C.O.D. orders.

POSTAGE, HANDLING & INSURANCE
\$ 00 to \$10.00 \$.75 \$25.01 to \$50.00 \$1.50
\$10.01 to \$25.00 \$1.00 Over \$50.00 Postpaid

NEW HOURS: 9:30 A.M. - 9:00 P.M. Mon. - Fri.
Sat. 10:00 A.M. - 5:00 P.M.



QUALITY U-CONTROL BALSA KITS

28½" Wingspan

\$15.00

Each Kit

- No. 201 P-40 E Curtiss
- No. 202 P-51-D Mustang (illus.)
- No. 203 Messerschmitt ME-109
- No. 204 Zero Fighter
- No. 205 Spitfire 5B
- No. 206 A1H Sky Raider
- No. 207 F-6F Hellcat
- No. 208 F-4U Corsair
- No. 209 Cessna 182
- No. 210 Hurricane

Above group for .15 to .19 engines

36" Wingspan

\$18.00

Each Kit

- No. 301 P-51 Mustang
- No. 302 Cessna 172
- No. 303 F8F Bearcat
- No. 304 AD-4 Skyraider
- No. 305 Spitfire
- No. 306 Messerschmitt

*For
.29 to .35
engines*



P-38 KIT -

\$20.00

FOR .29-.35 ENGINES Each Kit

- No. 307 T-6 Texan (41" Wingspan)
- No. 308 P-40 Warhawk (38" Wingspan)
- No. 401 P-38 (Uses two 12-29 engines. 40" wingspan.) Illustrated

ORDER DIRECT

AT THESE LOW PRICES!

All Kits have full scale plans in English. Landing Gear and Wheels. Pre-cut balsa and plywood parts ready to assemble. Metal cowl and plastic canopy where needed.

Send check or money order for direct, prompt shipment. All California orders must add 5% sales tax. Satisfaction is guaranteed.

KAYEFF, INC.

511 Campesina Road
Arcadia, California 91006

that year, several squadrons had been equipped with the type, and it became the major fighter plane in service. By early 1936, the first pontoon-equipped He-51Bs had been placed in service with coastal defense units.

All this was for training in expectation of the eventual start of offensive action. Just when Germany would be "forced" to attack its neighbors, was in the hands of the politicians. But the guns were already beginning to boom in Spain, and the eager Germans leaped at the chance to put their new weapons to the test before they would have to stake their country's future on them.

In August, 1936, the first group of "tourists" and a half dozen He-51s arrived in Spain to train Nationalist pilots. On Aug. 18, a pair of Spanish pilots in He-51s shot down several Republican airplanes, and the pretty biplane officially became a fighter. Soon, several Nationalist squadrons were equipped with Heinkels, and the masquerade dissolved, as German ground crews and pilots—"volunteers," of course—began to see action. The testing ground for future wars had been established.

In late October of 1936, however, the first Russian Polikarpov I-15 fighter biplanes were delivered to the Republican forces, and rapidly put the Heinkel to shame with their superior speed, maneuverability and rate of climb. Carrying more guns and more ammunition, the chubby Russian "Chato" was able to handle the He-51 with comparative ease. By early 1937, the German leaders



+ Graupner =

THE BEST IN FLYING

CUMULUS

Here is the king of sailplanes, by the king of quality; Graupner. Designed for towline and slope soaring, or power assisted thermal flying, 2 channel; rudder and elevator. Wing span 110½", weight (ready to fly), 56 oz. Foam wings are already balsa covered and sanded, fuselage is one piece of plastic ready to paint, all other parts sanded, and ready for "film" or paint.



\$169.95

CIRRUS

The Cirrus is a 1/6 scale model of a full size sailplane manufactured in Germany. Wing span of 118 inches, overall fuselage length of 49 inches. Fuselage is basically composed of three high impact molded plastic pieces. Wings, tail and stabilizer, are built up in the conventional manner. A high performance soarer for 2 channel R.C.

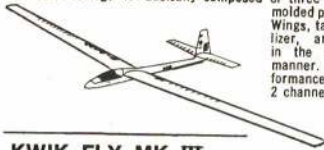

\$79.98

KWIK FLY MK III

This is the world champion model designed by Phil Kraft for acrobatics. Wing span of 59½ inches and will take up to a .60 for 4 channel RC equipment. This model is easy to build due to its extensive pre-fabrication.



\$95.98

Dealers, Wholesalers, Write to AHM Today to Order These Hot Items.

Catalogs: CA-27—Gas Model Cat. 10c. CA-15—1971 4-color plastic kit cat. (new), 50c. CA-24—1972 Airfix color cat. 68 pages \$1.50. CA-25—Airfix price list (no pictures) 10c. Allow five weeks for catalogs, by third class mail. For first class mail add 25c for each cat., individually, or 75c for all catalogs, normal ten days delivery.

Mail Orders—try your AHM dealer first. If he cannot supply items desired, send his name and address with your order. Orders less than \$3.00, add 50c handling charge. If the service is not completed promptly, write boss, 1240 Guilbert Road, Meadowbrook, Pa., 19046. For prompt attention to mail order, address to:

CS 2062



ASSOCIATED HOBBY MANUFACTURERS, INC.
627 E. Cayuga St., Phila., Pa. 19120



Christmas creations a la Black Forest, handmade in Hawaii from original, three-dimensional designs to delight the collector. For treasured gifts, choose from over 200 items, each hand-painted in gay Christmas colors.

Our catalog sent on request — \$1 Deposit Refundable.

ORDERS AIRMAILED WITHIN 48 HOURS OF RECEIPT

A. ALEXANDER CO.

98 Riverside Drive,

New York, N. Y.

EXCLUSIVE FOR THE MODELER
FROM DEMBROS HOBBIES

CHECK THE STARS THAT
MAKE UP STARFLITE

STAR-
FLITE
\$199.95



- ☆ Extra Transmitter Power Output
- ☆ Fixed Frame Rate Logic
- ☆ New Rand 2 Axis Sticks
- ☆ White Vinyl-Clad Trans Case
- ☆ Provisions for Buddy Box Installation
- ☆ Lowest Cost Basic-Full House System
- ☆ Charger and All Nicads Included
- ☆ New 2-Wire Battery Pack
- ☆ New 3-Wire Servos
- ☆ I.C. CHIP Receiver Decoder
- ☆ I.C. CHIP Bridge Servo Amplifier
- ☆ Small Size—Lightweight
- ☆ 90-Day Factory Warranty
- ☆ Choice of Servos—C-E1, C-E2, C-E3
- ☆ Choice of Flat or Square Battery Pack

27 MHZ
w/C-E1 servos

● 72 MHZ, add \$10.00
C-E2 and C-E3 servos, add \$3.00 per servo

The full retail of this high quality radio will be \$269.95 — introductory offer of \$199.95 good 'til January 31, 1973

COMPETITIVE
PRICES
Plus
NO SALES TAX
IN N.H.

Dembros
HOBBIES, INC. 50 LIME ST. WASHUQUAH, N.H. 03080
AREA CODE 603 / 882-9492

For fast service send M.O. or bank check. We allow personal checks to clear before we ship. Bank-america and Master Charge accepted. Include M.C. Interbank Number. (lower left corner) and expiration date.

were in something of a panic. The He-51 was transferred to ground-support duties, and Bf-109s were rushed into action in Spain even before Luftwaffe units in Germany had gotten theirs.

Bombing and machine-gunning in close support of ground troops was much more appropriate to the talents of the He-51, and much of the tactics used for many years after had been worked out in Spain with this airplane. The He-51 was in action throughout the Spanish Civil War in this fashion, 135 having been delivered by the end of hostilities in April, 1939.

The lessons learned by the Germans in this practice war resulted in the He-51 being replaced in all combat units by the autumn of 1938. The remaining aircraft were then used for training during World War II, for it quickly became outdated even for ground-support uses.

All told, some 700 Heinkel He-51s were built by Heinkel, Arado, Erla and Fieseler between 1933 and 1937. Had

GETTING STARTED IN

R/C

Nineteen chapters of this informative series are now in a single volume at the low price of \$1.25 ppd. Use this book as a firm foundation for a start in Radio Control.

CONTROL-LINE

It's Vol. II in AAM's library series for the novice and the expert. Chapters cover all aspects of C/L—where to start, how to build, trim and fly plus a thorough review of competition events. \$1.25 ppd.

All 3 for \$3.00 or
\$1.25 each

R/C CAR RACING". Volume III of the AAM Library series is ready and waiting for you. Everything about R/C Cars is explained for the beginner and professional alike. History and basic elements, engines, chassis, learning to drive, ROAR rules, and that's just the beginning.

THREE GOOD REASONS WHY YOU SHOULD SEND TO:

GETTING STARTED
Potomac Aviation Publications
733 15th Street, N. W., Suite 526
Washington, D. C. 20005

Tech IV Retract Servo Kit

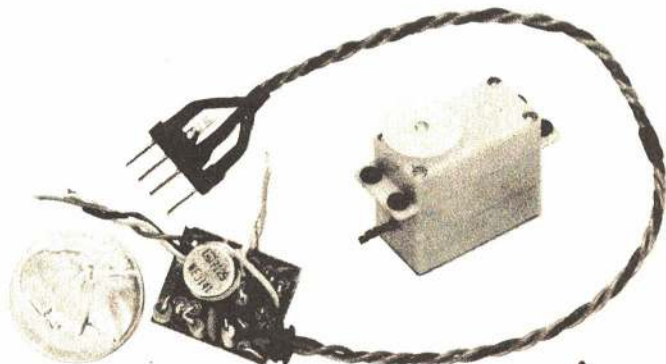

Extra Gears Built in for
Extra Power

Approximately 2 seconds transit time
for 180° Operation

7/8" wide x 1 5/8" long x 1 1/2" tall
Length Including mounting

Ears — 2 3/4"

Retract Servo Less Conn. **\$19.75**

Retract Servo w/Brunner **\$20.75**

Retract Servo w/Mult. **\$21.75**

Write for New Low Prices on Tech IV Servo Kits

royal

Electronics Corporation

2119 SO. HUDSON, DENVER,
COLORADO 80222 (303) 756-2281



O P S SPEED WITH TUNED PIPE
MARINE, CAR, AERO R C AND SPEED VERSIONS

aps
60
Front Intake
RC
or
Rear Intake
SPEED



O P S FI-60 "URSUS"

FEATURES

- A. B. C. PISTON & SLEEVE ASSEMBLY
- SCHNUERLE DIRECTIONAL PORTING
- TWIN PRECISION BALL BEARINGS
- SMOOTH IDLE
- INSTANT THROTTLE RESPONSE
- HEMISPHERICAL COMBUSTION CHAMBER
- SQUISH BAND HEAD

READILY AVAILABLE PARTS
MUFFLERS — PERFORMANCE GLOW PLUGS

Shamrock Competition Imports

P. O. BOX 26247
NEW ORLEANS LA. 70126
(504) 242-5967

SEE IT AT YOUR DEALER — ASK FOR FREE NEWS LETTER

they been all-metal, and had they not been subjected to the abuses of training squadrons, some might have survived. But there is no evidence that even a single one remains today. Few tears have been shed over this loss, for there are much more important airplanes which have been lost and which deserve the tears. And while the He-51 certainly played a role in the prelude to the Second World War, it would be stretching the truth to call it an important airplane.

But if the war had started a few years earlier,

Versions and Variants

- He-51a—4th He-49 prototype; D-2727
- He-51A-0—9 pre-production models built 1933-34
- He-51A-1—1st production run; 150+ built 1935
- He-51A-2—He-51A—1 tested on floats; D-IFTI
- He-51B-0—12 pre-production models built 1935
- He-51B-1—main production version
- He-51B-2—46 He-51B-1 with floats
- He-51B-3—high-altitude version with longer wings
- He-51C-1—100 built in 1937 by Fieseler for Spain
- He-51C-2—21 modified He-51C-1
- He-52D—float-equipped high-altitude version, lost on first flight
- He-52E—high-altitude interceptor; never built
- He-51W—He-51a tested on floats

Specifications of He-51B-1

Dimensions

- Length—27' 6 $\frac{3}{4}$ "
- Wingspan—36' 1"
- Height—10' 6"
- Wing Area—292.8 sq. ft.
- Empty Weight—3,247 lbs.
- Gross Weight—4,470 lbs.

Performance

- Top Speed—205 mph
- Cruising Speed—174 mph
- Range—240 mi.
- Service Ceiling—25,000'

ORDER REV-UP PROPS HERE

These Props were manufactured with quality control to give true pitch on both blades and outstanding balance. They feature the first real fuel proof finish. They can help you win!

SPECIAL PRO SERIES 2
Northern Hard Maple & Beech

Size	Price
6-3	.60
6-3 $\frac{1}{4}$.60
7-3 $\frac{1}{2}$.80
7-3 $\frac{3}{4}$.80
8-3 $\frac{3}{4}$.80
9-6	.85
9-7	.85
9-7 $\frac{1}{2}$.85
10-4	.95
10-6W	.95
10-6EW	.95
10-8W	.95
11-6	1.00
11-7	1.00
11-7 $\frac{1}{2}$	1.00
11-7 $\frac{3}{4}$	1.00
11-8	1.00
11 $\frac{1}{2}$ -6	1.00
11 $\frac{1}{2}$ -7	1.05
12-6	1.10
14-6	1.35
16-4 $\frac{1}{2}$	1.75

SPEED & RACING SERIES 400
Northern Hard Maple

Size	Price
4 $\frac{1}{2}$ -6 $\frac{1}{2}$.65
4 $\frac{1}{2}$ -7	.65
5-4 $\frac{1}{2}$.65
5-5	.65
5-5 $\frac{1}{2}$.65
6-7 $\frac{1}{2}$.70
6-8	.70
7-6	.75
7-7 $\frac{1}{2}$.75
7-10 $\frac{1}{2}$.75
7-11	.75
8-8	.80
8-8 $\frac{1}{2}$.80
8-9	.80
8-9 $\frac{1}{2}$.80
8 $\frac{3}{4}$ -8	.90
8 $\frac{3}{4}$ -8 $\frac{1}{2}$.90
9-8	.90
9-8 $\frac{1}{2}$.90
9-13	.90
9-13 $\frac{1}{2}$.90



CUSTOM SERIES 75
Gum Wood"

Size	Price
5 $\frac{1}{4}$ -3	.45
5 $\frac{1}{4}$ -4	.45
6-3	.45
6-3 $\frac{1}{4}$.45
6-4	.45
7-4	.55
7-6	.55
8-4	.60
8-5	.60
8-6	.60
9-4	.65
9-5	.65
9-6	.65
9-7	.65
9-7 $\frac{1}{2}$.65
9-8	.65
10-4	.70
10-5	.70
10-6	.70
10-6 $\frac{1}{2}$.70
10-7	.70
10-8	.70
11-4	.75
11-5	.75
11-6	.75
11-7	.75

Size	Price
11-7 $\frac{1}{2}$.75
11-7 $\frac{3}{4}$.75
11-8	.75
12-4	.80
12-5	.80
12-6	.80
12-6 $\frac{1}{2}$.80
12-7	.80
13-5	.80
13-6	.95
14-5	.95
14-6	1.05
14-6	1.05

NEW PYLON PROPS
9 x 8 $\frac{1}{2}$ 8 $\frac{3}{4}$ x 8 $\frac{1}{2}$

Clip out this ad and use it to order any of these fine props. Send Check, M.O. or specify COD. Kansas Residents please add 3% sales tax.

Name _____
Address _____
Zip _____

Mail to: **J. T. FINLEY**
6540 E. Central
Wichita, Kansas 67206

DEALER INQUIRIES INVITED

**GET YOUR
PLAN SERVICE
CATALOG
NOW**

PLANS CATALOG
AMERICAN MODELER
733 15th STREET, N.W.
WASHINGTON, D.C. 20005

JUST 25¢

RC Helicopter's Bell Jet Ranger

RC Helicopters Inc invited by the U.S. Gov't to demonstrate its all new Bell Jet Ranger at the International Fair

For 10 consecutive days, it shows each day, the model proved its reliability and maneuverability. Flying in a 40' x 60' confined area in front of the U.S. Pavilion, its stability & ease of handling was witnessed by 3500-4000 people at each show.

FOR BUYERS OF RC HELICOPTERS & RELATED PRODUCTS, RC HELICOPTERS, INC.



at the Zagreb International Fair, Sept. 7-17, 1972, Zagreb, Yugoslavia

Available at your hobby dealer
List Price \$475.00 LESS ENGINE & RADIO
manufactured in the U.S.A. by

RC Helicopters, Inc. 4550 White Plains Rd. N.Y. N.Y. 10470
212 324 3441
Dealer inquiries invited

NEW CONCEPT

in Rubber Powered Models

NO PAPER - ALL DIE CUT COLOR PRINTED
BALSA WOOD FOR QUICK
EASY ASSEMBLY



20" Wingspan
Formed wire landing gear
Propeller wheels and
Decals included

Citabria
★★★★★

\$1.95

Get them all...



Cessna Cardinal
KIT NO. 404

Piper Cub J-3
KIT NO. 407



L-19 Bird Dog
KIT NO. 405

Buy it and fly it today!



MIDWEST PRODUCTS CO.
Hobart, Indiana



72 Series Hirtenberger Engines

The most powerful muffler equipped R/C engines in the world!

HP40F-RC

Ideal pattern engine
Excellent idle
.90 horsepower

\$56.95
(with muffler)



HP40R-PR

Perfect for RC pylon
Dependable power
1.2 horsepower

\$59.95
(with RC
mixture venturi)

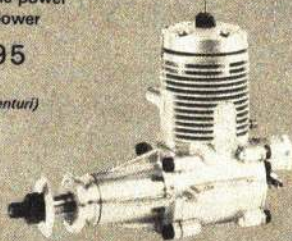

HP61FR-RC

Pattern and scale leader
Brute power
1.3 horsepower

\$84.95
(with muffler)

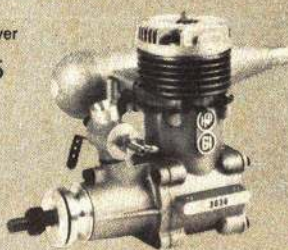

HP61RR-RC

Open pylon and marine use
All new disk rotary valve
1.52 horsepower

\$92.95
(Marine version
\$102.95)



HP ENGINES...THE NEW BREED!

Muffler as part of integral design
World Championship performance with handling qualities so gentle they are ideal for sport flying
Schneurle ported for competition power
Lowest vibration of any high powered 61
Coolest running of any 61 engine
Old World craftsmanship and care throughout

ALL HP PARTS CARRIED IN STOCK - IMPORTED BY



NELSON MODEL PRODUCTS

6929 WEST 59TH STREET • CHICAGO, ILLINOIS 60638 • (312) 586-7101

Changing Address?

Please let us know in advance
— five weeks notice would help!
For fast service, attach current
mailing address label in space
provided. Then PRINT full name
and address below.

Check correct box —
and enclose payment

One year \$7.50 Three years \$20.00
 Two years \$14.00 Renewal

Name _____

OFFER LIMITED TO
U.S.A. AND CANADA

Address _____

City _____ State _____ Zip _____

AMERICAN Aircraft MODELER

733 Fifteenth St. N.W.

Washington, D. C. 20005

66

RC HELICOPTERS

(Continued from page 42)

Everybody seemed to have a good time, made new friends, and learned a lot.

The free-flight helicopters had their day on Thursday in a contest sponsored by the National Free Flight Society. Tony Naccarato won first place with his new four-bladed torque reaction job. D. Lee Taylor came in second with his venerable sport coupe somewhat resembling the Filper helicopter. His and Tony's machines both obtained their control for turning and flying forward by means of vanes in the slipstream of the small propeller. Glen Lee's larger two-blader had the engine below, with the propeller at the bottom of a shroud, some thrust augmentation being thereby gained. Taylor's and Lee's helicopters have probably won more trophies than any other helicopters in this country.

All three designs had hingeless but flexible rotors with blades free to pitch or feather and with balance weights ahead of the leading edge of the blades. Taylor's and Lee's also had aerodynamic tabs on short booms behind the blade tips for quicker change in blade pitch for autorotation. This might be an excellent system for use on RC copters if the blades could be controlled cyclically by some kind of swashplate. At last autorotation would be possible, and the hub would be quite simple. However, test stand experiments by Gene Rock showed that these rotors go ape above about 400 rpm in a slow version of classical flutter. Viscous damping (thick grease) on the blade pitch bearings cured that, but there is still the control problem and the question of forward flight behavior.

SPITFIRE

(Continued from page 26)

for proper fit in the wheel wells as construction progresses.

Now is the time to install linkage for moveable ailerons, navigation lights and wiring, flaps, etc., if you wish. The wing tip lights on the original were left hanging from the end of the wing until the tips and top covering were in place and the wing shaped. They were then epoxied in place, covering the bulb completely with epoxy. When dry, the epoxy was filed and sanded to form the lens and housing, and the entire area was painted the color of the lens. (Red on the left wing and green on the right wing.) Mask the lens area, and paint the surrounding area silver. The silver dope is covered by the finish coat later and allows light to shine through the lens but not the surrounding area.

The fuselage is constructed of balsa blocks glued to a built up crutch. The various blocks are tack glued in place, and the entire fuselage is carved and sanded to shape, using cross section templates. After shaping the fuselage, remove the blocks and hollow as much as possible without sacrificing strength, particularly in the aft sections of the fuselage. Shape and glue 1/16" balsa formers inside the blocks in the positions shown on the plans. This provides



TOWER HOBBIES

P.O. BOX 2874 STATION A • CHAMPAIGN, ILLINOIS 61820

DECEMBER SPECIALS

RC KITS: MARK'S Windward Glider \$18.00, Windfree Glider \$23.50; MACO Jet Star \$34.00; AIRTRONICS Olympic 88-99 \$28.50, Mini-Olympic \$17.50; ANDREWS Mini-master \$21.50, Trainermaster \$24.50, Sportmaster \$30.75; BRIDI Kaos \$39.80, RCM Trainer \$35.95, RCM Basic Trainer \$20.75; JOHNNIE CASBURN Super Lucky Fly \$47.50; DUMAS Hi-Pro Glider \$29.95; GOLDBERG Ranger 42 ARF, Falcon 56 \$13.95, Skylane 62, Sr. Falcon \$25.50, Skylark 56 \$16.75; GRAUPNER Kwik Fli III \$41.00, Middle Stick \$31.00, Cirrus Glider \$39.00, Cumulus Glider \$92.50; JENSEN Das Ugly Stick \$39.00; LANIER Invader \$44.95, Jester \$42.75; MIDWEST Cessna Cardinal ARF \$15.95, Ez Juan Glider \$20.95, Das Little Stick \$16.25; STERLING Fledgling \$18.50, Lancer \$19.95, Schweizer 1-34 \$20.95, 1-26 \$14.95; TOP FLITE P-51 Mustang \$30.00, P-40 Warhawk \$33.50; VK Navajo, Cherokee \$27.75, Cherokee Babe \$19.75, Nieuport 17 \$31.50, Fokker Triplane \$34.00

RC ENGINES: ENYA .09 \$12.45, .15 \$13.75, .19 \$15.75, .19 BB \$25.50, .29 \$18.25, .29 BB \$23.25, .35 \$19.50, .35 BB \$22.95, .45 BB \$31.00; FOX .15 \$12.00, .25 \$14.25, .36 \$16.50, .40 \$18.00, .60 Eagle \$34.75; HP .61 Bluehead w/muffler \$55.95, .40 FR w/muffler \$39.25; K&B .40 \$25.75; VECO .19 \$20.75, .61 w/Perry and muffler \$52.50; NORTHFIELD-ROSS Std Aluminum Twin \$106.00, Black anodized Twin \$124.00; OS MAX .10 \$12.75, .20 \$18.25, .25 \$19.75, .30 \$20.50, .35 \$20.50, .50 \$31.50, .60 Goldhead \$43.50, .30 Wankel \$70.00; SUPERTIGRE G 21/29 RV ABC \$27.00, .51 \$28.25, .60 \$35.25, .60 Bluehead \$44.75; WEBRA .40 Blackhead \$45.00, .61 Blackhead \$60.50, .61 Blackhead Marine \$84.00

RC ACCESSORIES: POLYTHERM Heat Gun \$28.00; SEALECTOR Sealing Iron \$10.95; ROBERT Super Shoe \$2.25, Hinge Points (6) \$7.75, (15) \$1.55, Drill Jig \$2.25; DUBRO Prop Balancer \$2.50, Nylon Hinges (6) \$.95, (15) \$2.10, Kwik Glow Cord Set \$1.70, Ball Wrench Set \$3.35, Steerable Nose Gear complete \$2.50, Servo Mounting Hardware \$1.00; GOLDBERG Retracts (3) \$14.75, (2) \$7.95, Klett Hinges (7) \$.95, (15) \$1.70, Safety Driver \$.90; KO MUFFLERS .19-.30 \$10.25, .35-.61 \$12.25; UNIVERSAL Scale Wheels 3" \$3.80, 3 1/4" \$3.95, 3 1/2" \$4.10; DEVCON 5 Minute Epoxy Small \$.90, Large \$1.60; FOX RC Long or Short Glow Plugs \$.90 each, 12 for \$8.50; A-JUSTO-JIG Full House \$37.35

DIGITAL PROPORTIONAL RADIOS: KRAFT 5 Channel KP-5 \$240.00, KP-25 \$103.00, KP-4B \$333.00; MRC F724 \$225.00, F710 \$235.00, F713 \$125.00, Crystals (pair) \$9.00; MICRO CRAFT G45 4 Channel \$199.95

RC HELICOPTERS: DUBRO Whirlybird 505 \$87.50, w/K&B .40 \$105.00; HEGI Bell Huey Cobra \$280.00; KALT Bell Huey Cobra 450 complete with ENYA .45 engine and all accessories \$300.00 (We highly recommend this one. See October Model Airplane News P-74 for full details.)

SUPER MONOKOTE

6 FOOT ROLLS

OPAQUES: Red, White, Orange, Yellow, Clear, Aluminum, Gray, Blue, Dark Blue, Black, Chrome, Olive Drab \$5.00

TRANSPARENTS: Yellow, Orange, Red \$5.60

METALLICS: Plumb crazy, Green, Blue \$6.50

SOLARFILM

6 FOOT ROLLS

OPAQUES: Dark Red, Bright Red, Dark Blue, Light Blue, Orange, Yellow, White, Black, Silver \$4.50

TRANSPARENTS: Yellow, Orange, Blue, Red \$5.00

METALLICS: Green, Gold \$6.00

COD PHONE ORDERS

Can't wait for our sudden service by mail? Then try our super sudden same day COD shipment service. Call 217-356-4294 until 9:00 P.M. Call Today — Build Tomorrow!!

ALL NEW CATALOG

Over 60 manufacturers at the lowest prices anywhere! All yours in our completely new Fall discount catalog. Send 25c in coin or stamps for your catalog, or receive yours free with any size order. Do it TODAY!!

HOW TO ORDER

Add \$1.00 to each order for full insurance, postage and handling, Alaska, Hawaii, Canada, and Foreign orders, add \$2.50. Check or money order only. Current catalog included with every order. SATISFACTION ALWAYS GUARANTEED

A NEW GENERATION...



\$59.50
POSTPAID

LITTLE BIG DADDY 66

- EASY TO BUILD AND FLY
- IDEAL FOR THE BEGINNER
- KIT SANDED AND MACHINE CUT

Write For Free Brochure
TEXAS

MODELS UNLIMITED

1623 DUMAS DRIVE
AMARILLO, TEXAS 79107
AC 806 383-1301

NEW! MARK II TWIST LOCK SPINNERS!

FROM THE WILLIAMS BROTHERS
INNOVATORS OF QUALITY MODEL ACCESSORIES

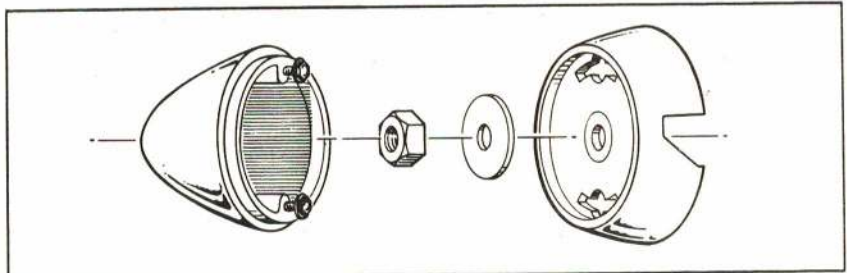

- PERFECT FOR USE WITH ELECTRIC STARTERS
- RAKISH MUSTANG STYLING
- LEFT OR RIGHT HAND ROTATION
- SUITABLE FOR CONVENTIONAL OR PUSHER PROPS
- NO UNSIGHTLY EXTERNAL SCREWS OR HOLES

Precision molded of durable nylon in choice of six colors (red, yellow, blue, black, white, orange) and eight sizes.

DIAMETER: 1 1/2" 1 3/4" 2" 2 1/4" 2 1/2" 2 3/4" 3" 3 1/2"
PRICE: 95c \$1.05 \$1.35 \$1.55 \$1.95 \$2.15 \$3.95 \$5.45

NOTE: 3 1/2" DIAMETER SPINNERS ARE AVAILABLE IN CHOICE OF P-51 OR P-40 TYPE.

SEE THEM AT YOUR LOCAL DEALER. IN CASE OF SUPPLY DIFFICULTY, ORDER DIRECT FROM THE FACTORY.

SEND 25c FOR COMPLETE CATALOG

181 B ST. • DEPT. A • SAN MARCOS, CA. • 92069



PROVEN
IN
THOUSANDS
OF TEST
FLIGHTS!



G45 SPACE COMMANDER

Proportional System with
Exclusive Integrated Circuit
Servo Amplifier

\$259.95

Sugg. List

With all NICKEL
CADMIUM BATTERIES
AND CHARGER

Micro Craft offers the ultimate in dependability and economy. Our products are the result of continuous research, extensive field testing, incorporating the most advanced design techniques.

Send for descriptive leaflet.
DEALER INQUIRIES INVITED

Do not confuse this set with others packaged in our old transmitter cases. Insist on the genuine G45 Space Commander by

MICRO-CRAFT CORP. 314 FIFTH AVE., DEPT. AM1272 N.Y., N.Y. 10001



HOBBY WORLD is where you are!
A HOBBY WORLD is what we are!

**Don Lowe's
"Phoenix V"**
\$49.95

Kit includes fiberglass fuselage and vertical fin. Bulkheads and maple engine mounts installed. Foam wing and stab included in kit.

Feature
of the Month



DEALERS—get your special price list. These kits carry full dealer discount. Write or call for full information!

**DADDY
RABBIT**



Sleek fiberglass fuselage and vertical fin; foam wing and stab. Quality kits with bulkheads and maple engine mounts installed.

**A-6
INTRUDER**



\$49.95
each

1/4 MIDGETS

MINNOW
P-51
P-63 KING COBRA

\$34.95
each

ORDER TODAY! Make a list of what you need and write or call for confidential price list. We've got fast service 24 hours a day . . . save the Bob Reuther way!

**BOB REUTHER'S
HOBBY WORLD**

6602 HIGHWAY 100 DEPT. A
NASHVILLE, TENNESSEE 37205, U.S.A.
24 HOURS: DAY (615) 356-1225
NIGHT (615) 352-1450

**TENNESSEE'S
LARGEST
SHOP**

stiffness without adding excessive weight.

Epoxy the fuselage crutch to the wing, lining the wing up carefully to insure correct incidence and planform alignment.

The horizontal and vertical stabilizers can be built up, or made by laminating two 1/8" balsa sheets with a hollow 1/4" balsa core. I tried both methods, and the weight difference using the latter method is negligible if you choose your wood carefully (Sig contest balsa was used on the original). The elevators and rudder are solid contest balsa, hinged as shown on the plans. This type of hinge is slightly difficult to construct, but it closely approximates the hinges used on full scale aircraft.

Glue the empennage in place, complete all linkage hookups, and install all lower fuselage blocks and wing center section sheeting. Note that the bottom center wing covering is flat at the front and blends to an inverted gull section at the flaps.

Most of the cockpit details on the original were finished prior to installation of the upper fuselage blocks. When the cockpit area is finished to your satisfaction, glue these blocks in place, add the wing fillets, and the model is ready for finishing. I used Sig polyester resin and fibreglass cloth on the original. I have tried many finishing methods, and found that the use of fibreglass results in an extremely tough model, requires less time than dope and silk, and makes detailing (such as scribing panel outlines) much easier. The finished model, ready to fly, weighed in at six lb. 12 oz. which compares favorably with other models of this type. The use of fibreglass doesn't present a weight problem if it is applied sensibly.

To finish the model using fibreglass, give the airplane a final sanding, making certain that all contours and shapes are correct. Cut a piece of glass cloth slightly larger than the area to be covered, lay it in place, and coat liberally with polyester resin. The cloth to cover the adjoining section should overlap with that already applied. Sand the resin in the overlap area to insure good adhesion.

After completing the first coat, sand the entire coating with coarse paper (80 grit aluminum oxide paper works well) to remove gloss and rough edges. Use a sanding block where possible to maintain the basic contours of the model. Apply a coat of resin only, and wet sand with 220 and then 320 wet or dry

(Continued on page 87)

Hire the handicapped.

PAS

PUBLIC ADVERTISING SYSTEM
A DIVISION OF THE SCHOOL OF VISUAL ARTS



**BUILDERS — COLLECTORS
BUY - SELL - TRADE**

Did you know that there is a nationally advertised monthly publication designed just for you? A publication that deals in individual ads to buy, sell or trade model kits, railroad items, books, magazines, military items, etc.

Available at your local hobby shop or from the publisher — 35¢ per issue — subscription \$3.50 a year. Ad rates \$1.00 for 50 words or less. (One free ad with subscription)

The Collectors Journal

1225 Saxon Ave., Dept. MN
Bay Shore, New York 11706

DEALER INQUIRIES INVITED

Tired Of Cranking With A Bad Plug Or Weak Battery?



\$29.95

Post Paid Cent. U.S.A.
Ind. Res. Add 2%
Dealer Inquiries
Invited

CHARGE START is for YOU!

AMMETER INDICATION OF BATTERY &
PLUG CONDITION
SELF CONTAINED BATTERY AND CHARGER
PILOT LAMP AND REMOVABLE POWER CORD
3 x 4 x 5 ALUMINUM CASE

DEVELOPED & PROVED THRU
EXTENSIVE FIELD TESTING



Send check or money order to:

D A ENTERPRISES
BOX 335, HAUBSTADT, INDIANA 47639
MANUFACTURERS FOR THE AERO MODELER

**1973 R/C
PRODUCTS
DIRECTORY**

SIG MFG. CO.

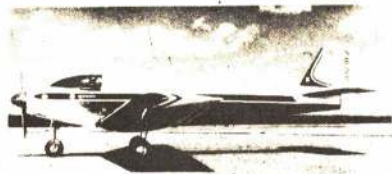

KOMET

Wing span 67" Area 670 sq. in.
Engine .45-.60 Weight 7 lbs.
Mat'l. Balsa fuselage, foam wing
Sug. retail price \$37.95 w/balsa
\$42.95 w/plywood

Designed by Maxey Hester and performs the complete AMA and FAI patterns in the hands of a sport flier.

PICTURES

SPECS

PRICES

SPECIAL PRE - PUBLICATION OFFER

TO BE DELIVERED JANUARY 2, 1973

OFFER EXPIRES DECEMBER 31, 1972

\$2.00

hundreds & hundreds & hundreds of listings
every manufacturer represented
most up-to-date information
only directory like it available

AFTER 12-31-72
\$2.25
post - paid

SEND TO: R/C PRODUCTS DIRECTORY
733 15th Street, N. W.
Suite 526
Washington, D. C. 20005

GET TOP PERFORMANCE!

USE
VIBRA-TAK

Slide Rule Tach.

Check the RPM's of your motor accurately. Instantly know what peak your motor is operating . . . get top efficiency and smooth running power. Engineer proven, VIBRA-TAK is a professional instrument built of polished, high stress aluminum. Carry it in your pocket or toolbox.



ONLY
\$5.00

including carrying case

Dealer inquiries invited

Order from:
VERDELL INSTRUMENT SALES CO.
P.O. BOX 212, EL CAJON, CALIF. 92020

- CHECKS MOTOR SPEEDS
- INTERNAL COMBUSTION ENGINES
- ROTATING & VIBRATION EQUIP. 2000 TO 21000
- GIVES DIRECT READINGS FROM 2000 TO 21000

IN CANADA

ACADEMY PRODUCTS



EVERYTHING FOR THE MODELER

Canadian Modelers: Canadian Dealer
Write for an ACADEMY CATALOGUE. Inquiries Invited.
75 cents, Postage free. Wholesale only.

ACADEMY PRODUCTS LIMITED

51 Millwick Drive, Weston, Ont., Canada.

**BEFORE YOU BUY FROM
SOMEONE ELSE...SEND
FOR OUR CATALOG**

SEND NOW FOR OUR CATALOG . . . enclose \$1 for handling — refundable with minimum purchase of \$10.

ESPECIALLY FOR CHRISTMAS!
indco
model aircraft
Box 543DA, Soquel, Ca. 95073

SUDDEN SERVICE PLANS

Full-Size Plans — Shipped First Class Mail Within 48 Hours — No Extra Charge

- No. C801, Winnie Mae—Spectacular RC Vega for strong 60 engine in 2"-1" scale, foam and balsa, lots of details. By Monty Groves. Two big sheets. \$4.50
- Also, special 1 1/2"-1" version for FAI scale, 40 thru 60's. Two sheets. Order as No. 0802. \$4.25
- No. C803, Thermal Dart—Enlarged and improved rubber-powered beginner's delight by Frank Ehling. \$1.00
- No. 0804, BV-141 B—Asymmetrical WW II fighter bomber in profile for 049 engine by Terry Aldrich. Easy to make, good flyer. \$2.00
- No. 0901, Sorcerer—Pee Wee 02-powered, free-flight flying saucer uses sheet wing, easy to make by Tenderfoot builder. \$1.00
- No. 0902, Cloud 9—Intricate contest winning Wakefield by Roger Gregory. Plan shows streamlined prop/hub design. \$3.50
- No. 0904, Antoinette—Signorino/Zundel RC 98" wing, nearly scale, flies well on .36, like powered glider. Plans 3 huge detailed sheets. \$9.00
- No. 0905, Mini Cat—Bud Atkinson scaled down the Cat series, for pulse or light digital and up to 19 engines. Easy to make RC sport flyer. \$2.75
- No. 1001, Phantom—Well-engineered RC Dyna-Jet-powered scale fighter by Ralph Saldívar is practical but noisy model. Highly detailed plane. Jet installation shown. \$4.00
- No. 1002, Hobbit—Simplified Nordic Al by Bob Stallock is steady on tow, all weather flyer. \$1.50
- No. 1003, Charger—1/2 A powered sweeping stunter does full pattern on long lines safely. \$2.00
- No. 1101, Autogiro—Simple 049-powered model builds fast and gives unique performance. Pusher prop or motor. \$1.25
- No. 1102, Aerobile—Large scale CL or RC of a famous Waterman roadable plane. Uses 45-60 motor. Wing detachable, car drivable! Large single-sheet plane. \$4.00
- No. 1103, Akromaster—RC scale/stunt model or real aerobatic plane for 45-60 engine. Fast and responsive, easy to make, simple shapes. \$2.75
- No. 1104, Tardon—Formula II semi-scale pylon racer or stunt plane for 40 engines. Won event at 1969 NATS. Groovy flier. \$3.00
- No. 1201, Stiletto—Unique 1/2 A proto model uses much-extended motor shaft for clean prop thrust and speed. \$1.00
- No. 1202, King Kong—Huge flat-land soarer for competition use has 12" wing of glass, foam, and balsa. By Sarpolus. \$3.25.
- No. 1203, 10-HI—Six-foot span, 049-powered flying wing is high-performance model with sporting flair. Huga plan. \$3.50.
- No. 0111, Dragonfly—Fast graceful competition stunter by Phil Kraft. Uses big 60's and retracts. \$4.00
- No. 0112, Toothpick—Long thin winged combat CL ship is both fast and quick turning. For hot 35's. \$2.25
- No. 0113, Luton Minor—Delightful 10-powered semi-scale RC for three light servos is high-winged parasol monoplane. \$2.25
- No. 0211, Cobra—Steve Wooley's great, smooth-flying CL stunt ship for 35's. Light model, ideal for both FAI and AMA patterns. \$3.50
- No. 0212, Voodoo—Converted Goldberg kit for streamer-towing RC combat, by Ed Sweeney. Two servos with 19 engine. For new event. \$2.75
- No. 0213, Gullotine—Modified from CL for RC combat. Maneuverable, fast, responsive, and fun. Glides well. For two servos and 19 engine. For new event. \$2.75
- No. 0312, EKKO—A compact FAI pattern and sport model for 35 engines. All wood low-winger. \$3
- No. 0311, Skydancer—Two-channel-equipped RC boost glider using aileron and elevator control. Lofted by new, powerful rocket motor. \$2
- No. 0411, P-51 Mustang—Semi-scale 60-powered with ARF Lanier or Dee Bee wing on balsa fuselage. Realistic and quick construction. \$3.25
- No. 0412, Grouper—Unique in appearance, oval balsa fuselage hides a big 60 engine. Easy-to-make stunter for commercial ARF wings. \$3.25
- No. 0413, Dauntless—Low-wing scale profile FF model for sport flying on inexpensive 020 engine. \$1.50
- No. 0414, Nesmith Cougar—Accurate scale CL model of boxy homebuilt. Fine beginner's scale model using 19. A winner with detail. \$3.50
- No. 0511, Five Wagon—Contest free flight model for 1/2 A, by James Clem. Diagonal-ribbed wing resists warps. \$1.75
- No. 0512, Platypus—Unusual-looking RC aerobatic seaplane, made with balsa-coverted foam blocks. Uses a 60. \$3.00
- No. 0513, Troop Glider and Tug—Two models, one a twin-engine, 10-powered C-46 Profile, the other a scale CG-15 troop carrying WW II glider. Both on one large plan. \$2.75
- No. 0611, Phatom Stunter—Very realistic jet-like model of Blue Angels plane with typical stunt moments and airfoil. For 35-45 engines. \$2.75
- No. 0612, Crusader Stunter—Anhedral wing, ventral fins and full array of missiles and drop tanks. It is a unique but truly competitive flyer on a 35 or 40 engine. \$3.00
- No. 0613, Simple-Fly—Semi-symmetrical CG airfoil low-wing on box fuse. Performance for beginner on 29 or novice contest ship with a 50. \$2.50
- No. 0614, Sopwith Pup—Single or multi-channel, nearly-scale model for 10 to 19 power. Highly detailed plans. Stable flyer. \$3.50
- No. 0615, Santana—Jon Davis' contest-winning towliner A/I. Uses fiber-glass boom, stiff wrap-resistant wing. \$2.00
- No. 0711, Phoenix 5—Don Lowe's latest in a series of swept-wing competition stunters for 60 and retracts. \$3.00
- No. 0712, Bonanza/Debonair—Build either V-tail or conventional version of this popular fast light plane for full-house radio and a strong 60. Fine-flying ships, foam wing construction. \$5.00
- No. 0713, I.F.O.—Would you believe a FF 020-powered flying saucer which really flies? Built-up construction looks real. \$1.00
- No. 0714, Helldiver—Semi-scale CL model of WW II torpedo bomber builds fast and is rugged. \$1.50
- No. 0811, Douglas Mailplane—Large FF scale of Western Air Lines M-2 biplane. For 09 power. Could fly with light radio. \$3.00
- No. 0812, Hot Canary—Unique Formula II/FAI racing biplane by Bob Sigelkoff. Although unusual-looking, it is fast and quickly built. \$3.25
- No. 0813, Pogo—Model of Owl Racer for Formula I features midwing, low stab, non-cheeked cowling. Very stable and plenty fast. By Bob Morse. \$3.50
- No. 0814, Flying Fortress—Not a scale plane, but a novel CL flying medicastel for a 19. \$2.75
- No. 0911, Fletcher—McCullough's magnificent tri-gear, low-wing crop duster scale job for 60's. Generous area and moments. All balsa. Highly-detailed plans on 2 sheets. \$7.50
- No. 0912, Killer—Fast, responsive combat plane. All-balsa for 35's has many wins. \$3.00
- No. 0913, ACE High—Featherweight 049-powered RO glider uses a set of ACE R/C foam taper and constant chord wing sets. \$2.25
- No. 0914, Sakitum!—Highly-developed 40-gram Wakefield plane by Brian Donn features latest trends in gadgets and design. Well-detailed plan. \$3.00
- No. 1011, FAI Man—Competition FAI free flight job for screaming 15's. Simplified construction with warp-preventing wing. Build a winner. \$2.75
- No. 1012, Peregrine—All-out RC slope soaring racer for ailerons and elevator. Balsa fuselage with foam wing. \$3.50
- No. 1013, Hi-Pro—Highly proficient slope/thermal soarer. Build several versions from these plans. Balsa wing and glass fuselage. \$3.50
- No. 1015, Marut—Named for the Wind Spirit. Designed for windy weather CL contests. Large-size jet appearance uses 45 engine. Two sheets. \$4.50
- No. 1111, Longster—Large-size free flight scale ship for 09 power, also ideal as small RC. Construction similar to real plane. \$2.75
- No. 1112, Buster—Built-up profile Goodyear racer well-streamlined and a winner. For hot 15's. \$1.75
- No. 1113, Bippi-Bipe—Delightful scale-like rudder-only or GG model for single channel and 09 engine. A fun plane. \$2.75
- No. 1211, Fireball—Jim Walker's great design presented as it was by Bruce Lund. For ignition 23's or smaller on glow. \$2.00
- No. 1212, Brooklyn Dodger—Sal Taibi's great old-timer FF job presented as it was by Bob Harrah. For ignition 23-35 or smaller glow engine. \$1.75
- No. 1213, Canus—Sixty-powered and large-size FAI aerobatic RC plane. Very quick building. \$4.00
- No. 0125, Firecracker—FAI scale RC pylon racer with special fast airfoil and homemade retracts (in text), a winner by Bob Root. \$3.50
- No. 0121, Penguin—Unusual scale CL flying model of post-WWII pre-flight trainer. Simple and RC-able. Uses 19 to 35 engine. 3-views on plan. \$2.50
- No. 0122, Pay-Up—TedDee 020-powered AMA Pay Load event winner also nice for sport FF. Simple and sturdy. \$1.50
- No. 0123, Nifty Novice—049 thru 15 power for monoplane or biplane Tenderfoot CL trainer. With power, bipe is stunteable. SPECIAL PRICE \$1.00. decal included.
- No. 0124, P-38—Semi-scale WWII fighter with single 049 flies rudder-only pulse RC with ACE mini-foam wings, others usable. \$1.25
- No. 0221, Big Flapper—Large high wing is docile flyer for a 60 engine and 4 channels. Nice trainer/sport plane. \$3.50
- No. 0222, BV-170—Threé 35's power this sort-of-scale German profile fighter. It is big, pulls hard in flight, stunts too. \$4.75
- No. 0223, Canard Drop-Off—Rubber pusher sport flyer drops its prop and rubber when unwound, then drops a piggy-back glider. All balsa and flies great. \$2.00
- No. 0224, Cardinal—Excellent FAI European-type RC pattern plane of foam/balsa construction. Up-to-date ship if for 60's, suitable for retracts. \$4.50
- No. 0321, Turbo-Pilatus Porter—Fine flying CO2 or Rubber powered FF scale model and scale floats for ROW. All on one plan. \$1.50
- No. 0322, Little Bird—Midwing RC pattern plane handles wide range of power up to 71's, yet is small in size. \$3.50
- No. 0323, Two For the Show—Biplane CL stunt for 049 Tee Dee. This one offers precision flying in small areas, great for practice. \$1.50
- No. 0324, 2T—ACE-foam-winged RC trainer for 049 power carries 2-channel bricks with ease. Ample wing area for long glides too. \$2.00
- No. 0421, Quarter Pint—A 020-powered Tenderfoot free flight patterned after an antique design of 30 years ago. With decal. \$2
- No. 0422, RCX4—Bat-like winged sport RC plane for big motors, 4-channels, and crowd pleasing flights. \$4.50
- No. 0423, Squeeze-Banger—FAI combat anyone? Fast flying 15 ship from Canada is a winner. \$2
- No. 0424, Dragonette—Compact version of Kraft's Dragon Fil uses hot 40 and flies just like a big one—fast and smooth. \$3
- No. 0521, Satellite 1000—Huge and highly-detailed plans for one of FF's most winning designs. For screaming 40's. \$8.50
- No. 0522, LH Rebel—Fast and very durable 15 Goodyear CL racer is a consistent winner. \$2.25
- No. 0523, Pegasus—A take-apart RC job designed for transportation in its own box. Full house with a 19, stunts well. \$2.50
- No. 0621, So-Long—miniaturized Old-Timer for 020 power event and sport flying. Easy to make. \$1.50
- No. 0622, Denight Special—Well updated four-year-old Forum I racer by deBolt has many unique features for speed. All balsa construction. Two-sheet plans. \$2.00

AAM PLAN SERVICE

733 Fifteenth St., N.W.
Washington, D.C. 20005

Please send the following plans by First Class mail, at no extra charge. I enclose \$_____ for payment.

For foreign orders please add 25% for postage.

Name _____
Address _____
City _____ State _____ Zip _____

PLAN NO. COST

# _____	\$ _____
# _____	\$ _____
# _____	\$ _____
# _____	\$ _____
# _____	\$ _____
# _____	\$ _____
# _____	\$ _____

Total: \$ _____

No. 0623, Chance Vought "Skimmer"—U.S. Navy experimental shipboard fighter is real flying saucer. For profile carrier events, by Frank Scott. \$4.50

No. 0721, Douglas Devastator—Navy Carrier competitor for 40 or 60 of colorful shipboard fighter. A tough plane and a winner. \$3.00

No. 0722, Wizard 350—Ron St. Jean's combination of past FF power winners in a 350 sq. in. 049 screamer. \$1.75

No. 0723, Quickie Mk 4—RC competitor for Class A and B. Conventional looking low winger flies easily, builds very fast. \$2.00

No. 0821, Capstan—For one- or two-channel RC, a small sport/scale all-balsa glider. Has a fine glide. \$2.00

No. 0822, Nemesis II—Howard Rush's winning AMA Combat ship. Ultra-light, balsa and silk, very quick. \$2.25

No. 0823, Apteryx—New style Mylar-over-foam wing on fast, tough, AMA Combat plane by Robert Mellen. Construction offers perfect airfoil and tapered wing. \$2.25

No. 0824, Ryan SC—Unusual 049 free flight scale model is low winger with excellent flight stability. Flies fast and handles wind easily. \$2.75

No. 0825, S.S.P. RC Helicopter—Gene Rock's simplified and well-proven design for home builder needs minimum critical machined parts. Features belt-drive, 45-60 engine, gyro stabilized main and tail rotors. Large, highly detailed plan is full-size including sub-assemblies. \$6.00

No. 0826, Full-size drawings for making special machined parts for Gene Rock's RC Helicopter. Not essential, parts are available from Stock Drive Products, Inc. See article. Parts plan only \$2.00

No. 0921, Hot Pants—Jerry Nelson's large-bodied, realistic-looking, home-built type RC Pattern design. Smooth flyer uses all-moving stab. \$4.00

No. 0922, Aqua-Vent Floats—Simple curves make these easy to build. Sized for 15 to 30 powered planes. Designed for quick lift-off with low power. \$2.50

No. 0923, Vertigo—A CL vertical take-off-and-landing biplane. Uses throttled 19 for power. Really flies, lots of fun. \$2.75

No. 1021, Bronco—A Class I or II Navy Carrier plane for two 19s or two 29s of the OV-1A C.O.I.N. fighter. The large plan sheets. \$6.00

No. 1022, Lockheed S1—Unique highly-detailed scale biplane of Lockheed's first airplane. Original dates to 1921. Design by M. Groves, uses a 40. Two sheets. \$7.00

No. 1023, Quasimodo—An odd-looking four-channel RC Sport job for 35s. Shoulder wing, tail dragger. A fun flyer. \$4.00

No. 1121, Warlock—Mid-wing, tandem bicycle retractable, all-flying stab, and swept wing are features of this 60-powered Pattern ship by Jim Willmot. Large plan. \$6.50

No. 1122, Sweet Pea—"Y" tailed CL stunter by Dennis Adamisin is consistent winner with semi-scale Good-year-racer appearance. Takes smooth 35 or muffled 40. \$3.50

THIS MONTH'S PLANS

No. 1221, Spitfire—Highly detailed, two sheet plans for 60-powered retract-geared CL scale model. A Nats winner and seventh in CL Scale World Champs. \$7.00

No. 1222, David—An Al Nordic for competition with A2s is stronger, smaller, easier to make, and has lower wing loading. \$1.75

No. 1223, Quicky 500—Glen Spickler's club pylon racer goes fast but is very quick-building, long-lasting, easy to fly and land. For TR type 40s. Great for grass-field sites. \$2.75

No. 1224, Snoopy—Sport flyer and trainer for 09 thru 35. Can use Top Flite Headmaster wing. \$2.25

R/C BOATERS:

EXCUSE US IF WE STRUT A BIT!

PARALLEL



Made of high tensile strength extruded aluminum

PARALLEL STRUT \$295 ea.

Complete with 2 Nyliner Bearings 4 Screws & T-Nuts

1 1/4" Depth
1 1/8" Depth
1" Depth
7/8" Depth
3/4" Depth
1/2" Depth
1" Depth

3/16" Boss
3/8" Boss

OCTURA MODELS

Shaft—steel

\$150 ea. 3 1/4" long

To be used with any of Parallel Struts at left.

3/16" DIA. PROPELLER SHAFT & DRIVE DOG COMBINATION

Drive Dog—Hardened, plated steel supplied with 8-32 cup point set screw

3/16" Bore
3/16" long

BALL THRUST BEARING

3/16" O.D. \$1.80
3/8" O.D. \$2.50

LOWER UNIVERSAL JOINT \$235 set

Use with Parallel Strut

3/16" to 3/16" shaft—OC610 F & M—7/16"
3/32" to 3/16" shaft—OC509 F & M—3/8"

STREAMLINED TAIL NUT

1 3/16" long, plated

10-32 thread, 75c ea.
OC6PNM—3/8"

If dealer cannot supply you—order direct—add 10% for postage and handling—Illinois customers include Sales Tax.

8148 NO. MILWAUKEE AVE. • NILES, ILLINOIS 60648

Feel and Fly like a PRO!

... with the GRAN PRIX R/C SYSTEM



The Gran Prix R/C System provides R/C flying at its best... at a Sunday Flyer price

\$399⁹⁵

• 6 CHANNELS • ANY FREQUENCY • DUAL STICKS •

NONE BETTER AT ANY PRICE!
(Single-Stick Model Add \$17.50)

The GRAN PRIX SYSTEM is guaranteed "ready to fly"... Install, charge batteries, and fly with **CONFIDENCE!**

Each Gran Prix System:

- has been flight tested in the air for 30 minutes or more.

- is packed with a certificate signed by test flyer giving date of flight.

As we said, "Fly with **CONFIDENCE!**"

Each component of the Gran Prix System has been carefully selected as best for its own function as well as to complement other components in the circuit, and each is operating at only a small fraction of its rated capacity. This provides an overload safety margin way beyond any demand that will be made of it.

All batteries are cycled three times prior to being installed in the system... and twice again before shipment. The system also goes through a complete cycle of operation to stabilize all components, by "burning in" before the actual flight test.

Is it any wonder we can offer a 120-day guarantee against defects in workmanship and materials, and say, "Install it and fly with **CONFIDENCE!**"

Write for complete brochure... the Gran Prix is only one of our six different types of systems.

CANNON
ELECTRONICS

13400-26 SATICOY STREET
NORTH HOLLYWOOD, CALIF. 91605
(213) 764-1488

Guillow's

**LOCKHEED
P-38 LIGHTNING**

"DESTINED TO BE THE SCALE BALSA KIT OF THE YEAR"

SCALE MODELER - JUNE, 1972 - Page 52

**3/4" SCALE
40" WING SPAN**



MANY, MANY OPERATIONAL
FEATURES. .049 TO .09 ENGINES
CONTROL LINE, FREE FLIGHT
OR RUBBER.



AVAILABLE
IN CANADA

KIT NO. 2001
\$18

PAUL K. GUILLOW, INC., Dept. A-6, Wakefield, Mass. 01880

See your local hobby kit outlet for these and all Guillow kits — check Yellow Pages under "HOBBIES". If none nearby, send direct to factory, adding \$1.00 packing and postage in U.S.A., \$1.50 outside U.S.A. Send 10¢ for Catalog

(Continued from page 82)

paper. The model is now ready for a coat or two of clear dope followed by color. I used Pactra military flats with excellent result.

One final note on finishing. Component parts such as ailerons, flaps, elevators, rudder, etc., should be as nearly finished as possible before installation. I try to have them ready for the final color coat before attaching them to the model. This requires the builder to apply the finishing steps outlined above to certain parts of the model such as aileron wells, flap wells, and horizontal and vertical stabilizer trailing edges before finishing the adjacent area. Care must be exercised when fibreglassing and painting to prevent spoiling an already finished area.

STERLING'S FOKKER

(Continued from page 18)

scale ship. Safest takeoff is a scale-like takeoff. When airborne, fly level for several moments to gain plenty of airspeed then climb at a shallow angle keeping this speed. Remember, the real Fokker did not climb like your pattern plane either. Perhaps one reason we enjoyed flying the model was our belief that a large diameter and low pitch prop should be used instead of the usual pattern size prop. Our Webra swings a 12-6 happily. Try one.

On one flight, I did not follow the above advice on landings. So, the Fokker flipped over because both altitude and airspeed weren't enough. This flipover was a bit rough and some damage was done. The landing gear bent aft and rudder became a tail skid. No damage to these parts, but the right top wing tip was bent. The leading edge sheeting cracked. Repairs were easy and quickly accomplished. Why the breakage? The wing struts are rigid; the breakage was at the strut area. It would seem better to have easily bent struts or quick-release attachment for them. The

MAKE WAY FOR THE WAVEMASTER!

The most beautiful amphibian ever offered.
A 6 ft. span R/C kit designed by Ken Willard.
The ideal sport plane - Quickly converts to land or water.
Suitable for any 4 channel proportional & .60 engine.

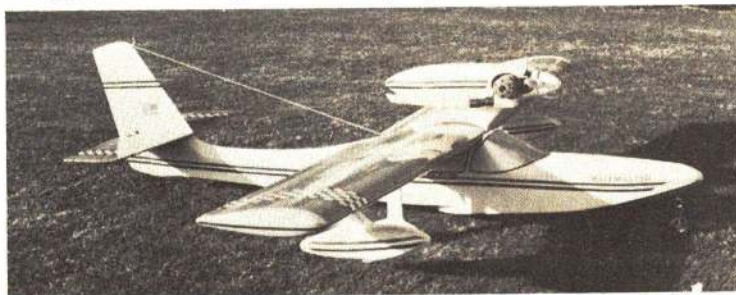

Precision molded and cut gleaming white plastic . . . foam cores only.
Balsa tail surfaces and specialized hardware.

WING SPAN 72" LENGTH 56" WT. 7½ - 8½ lbs.
\$59.95 FOB Daly City, California - Write for brochure

KING'S R/C DISTRIBUTORS

178 School St., Daly City, California 94014 • (415) 756-4910

NEW! PRECISION PROP BALANCER
WILL BALANCE PROPS TO WITHIN A FRACTION OF A GRAM!

MAKE NO MISTAKE, this is not another gadget but a QUALITY PRECISION INSTRUMENT. Your props will be balanced with FAULTLESS accuracy on TWO PRECISION STAINLESS STEEL BALL BEARINGS. Because of this, the Balancer need not be used to give accurate results.

YOU WILL GET:
* BETTER IDLE * LESS VIBRATION * GREATER R.P.M. * LESS ENGINE WEAR

Comes in protective plastic case complete with insert to fit speed props.

Only **\$5.95**

Dealer and Distributor Inquiries Invited

Saving all those Nicked Props will make this Precision Prop Balancer pay for itself!

QUALITY HOBBY PRODUCTS, CO.
Route 3, Box 225 • Leeds, Alabama 35094 • (205) 699-2186 699-2187

M.E. DIESEL ENGINES

HERON .059 CU. IN.
\$14.95 P.P.

SNIFE .091 CU. IN.
\$15.95 P.P.

SNIFE R.C. - \$16.95 P.P.
SILENCER - \$4.45 P.P. EACH ENGINE

HOBBY HIDEAWAY DELAVAN, ILL. 61734

GET YOUR PLAN SERVICE CATALOG NOW

PLANS CATALOG
AMERICAN MODELER
733 15th STREET, N.W.
WASHINGTON, D.C. 20005
JUST 25¢

THE WORLD'S HIGHEST PERFORMANCE SAILPLANE

\$59.95 SEE YOUR DEALER OR YOU MAY ORDER DIRECT

ASW-17

WING SPAN 132 INCHES
LENGTH 49 INCHES
FLYING WEIGHT 60 OUNCES

ASTRO FLIGHT is proud to present its new 1/6 scale model of Dr. Alexander Schleicher's outstanding ASW-17, which took First, Second, and Third place at the recent 1972 LSF North-South Challenge Meet in Bakersfield, California. This aircraft's superb aerodynamic performance makes it a must for the serious competition flier. Its breathtaking beauty and gentle control response in the air makes it equally at home with the Sunday flier. This deluxe kit contains a seamless fiberglass fuselage, spruce and balsa wing, and complete hardware package.

AFI

ASTRO FLIGHT INC.
2301 CHERYL PLACE
LOS ANGELES, CA. 90049



406 WEST WASHINGTON • HOOPESTON • ILLINOIS • 60942
PHONE (217) 283-5710 AFTER 4:00 P.M.

C/L ENGINES: FOX .15-\$7.50, .25-\$9.50, .35, .36X-\$12.00, .36XBB-\$15.00, .40-\$13.25; ENYA .09-\$9.50, .15-\$11.00, .35-\$15.50, .45-\$25.00, .60-\$38.50; O.S. MAX .10-\$8.80, .15-\$11.00, .20-\$12.00, .25-\$13.00, .30, .35-\$14.00; K&B .15-\$19.50, .35 Stallion-\$9.50; COX .049 BB-\$4.50, 3/\$12.60, .049 GB-\$5.50, 3/\$15.00, Medallion .049-\$7.50, .09-\$9.10, .15-\$11.25, Tee Dee .010-051-\$9.10, TD .09-\$10.50; MIDWEST Panther, Cougar-\$11.50, Magician 15-\$7.00, Magician 35, Kingcobra, P-51 Mustang, Messerschmitt-\$10.00, 3/\$27.00; TOP FLITE Super Monokote 4-\$23.00, 12-\$60.00, 9 assorted trim sheets-\$5.67, Mustang, Quik Fil III-\$31.50, SE5A-\$33.60, P-40 Warhawk-\$35.00, 2/\$66.00, Contender-\$25.50, Headmaster-\$13.50, Top Dawg-\$12.50, Taurus-\$29.00, Tauri-\$19.50; MIDWEST Cardinal-\$16.50, Little Stik-\$16.50, Sky Squire-\$24.50, Tri-Squire-\$13.50, Esquire-\$12.25, Lil Esquire, Tri-Squire-\$10.00; STERLING Fledgling-\$19.00, 1-26-\$15.00, 1-34, Rimfire, Lancer-\$20.00, PT-17-\$33.60; JENSEN Ugly Stik-\$40.00, wing kit-\$15.25; BRIDJ Kaos-\$39.50, wing kit-\$19.00, RCM Trainer-\$37.00; ROYAL B-25-\$56.50, P-38, Little Stinker-\$48.00, Cessna 310G-\$52.50, Spirit of St. Louis, Cessna 206-\$36.50, Cessna 182, Hein Sr.-\$40.00; AFI Malibu-\$18.50, Monterey, RF-4-\$22.00, high start-\$22.50; Windward-\$18.50; GRAUPNER Middle Stik-\$32.00, Cirrus-\$40.00, Cumulous-\$95.00; VK Cherokee, Navajo-\$28.00, Cherokee Babe-\$20.00, Mini-Flite Rivets-\$22.00; DREMEL Moto speed control-\$14.00, No. 271 complete-\$32.00, No. 281 complete-\$38.50, No. 572 complete-\$43.00; STAFFORD Commanche, Aircoupe-\$35.00, Sperry Messenger-\$32.00; Joy Mars-\$28.00, C-3-\$35.00; UNIVERSAL WHEELS 2½-\$3.60, 2¾-\$3.75, 3-\$3.90, 3¼-\$4.05, 3½-\$4.20, 3¾-\$4.35; HOBBYPOXY I-3/\$2.10, II-3/\$6.30, IV-3/\$4.20; AERO PREC. AT-6 Texan-\$26.00, Touchdown-\$16.75; A-Justo-Jig, reg.-\$29.99, full house-\$38.00, fuse adapter-\$8.00.

ALL POSTPAID — INSURANCE ADD \$.30

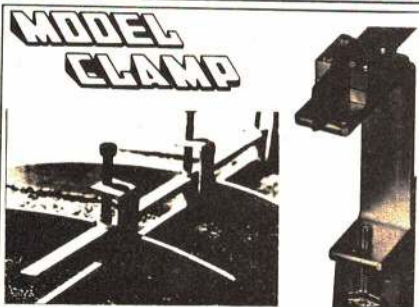

Our Model-Clamp is the most versatile clamp in the Hobby World. Can be used as a WING JIG. New from our Eng. Dept. The CAP-STRIP-CUTTER. A money saving Tool. Cut your own capstrips. Makes 1/4" and 3/16" strips from scrap balsa.

Model-Clamps per bag of 5	\$ 1.50
Cap-Strip-Cutter each	\$ 1.95
Alum. Reel 8" O.D. 5/8" Centerhole each	\$20.00
Complete Etc. Winch less Battery	\$97.50

ROSE IND. • 1190 N. ROSE • ESCONDIDO • CALIF. 92025

wings are fully cantilever and struts on the model are not essential to safe flight. So, don't fly with them except to look realistic. Fokkers without struts are not very realistic, for that matter any biplane without struts looks awkward.

Sterling has several other large stand-off scale models some of which are from kits that date back nearly ten years. I have had one of each and enjoyed them all. There was a P-51, Spitfire, and P-63 from WWII. They were kitted when our radios were not modern proportional rigs. In those days we used systems

called "reeds." These systems had a separate three-position lever for each control. The levers were normally at neutral. One blipped the lever to cause a blip on the control surface. Perhaps you can imagine the flight path of those large WWII Sterling kits when flown on reeds. The planes flew great. On modern proportional, they are superb. One other large RC kit from Sterling is the PT-17 Stearman biplane. This is a much more recent kit and is readily available. If you want one of the older WWII models, you will need to search many hobby shops to find one. It is worth the searching and the price is low.

ASSOCIATED DOMINATES 1972 R.O.A.R. RC CAR NATIONALS

1st-2nd-4th
Expert Class Road Race

*
1st
Expert Oval Race

*
1st
Amateur Road Race

*
1972 NATIONAL
CHAMPION

ASSOCIATED
ELECTRICS

7611 Madison Street
Paramount, Cal. 90723

Send for free catalog

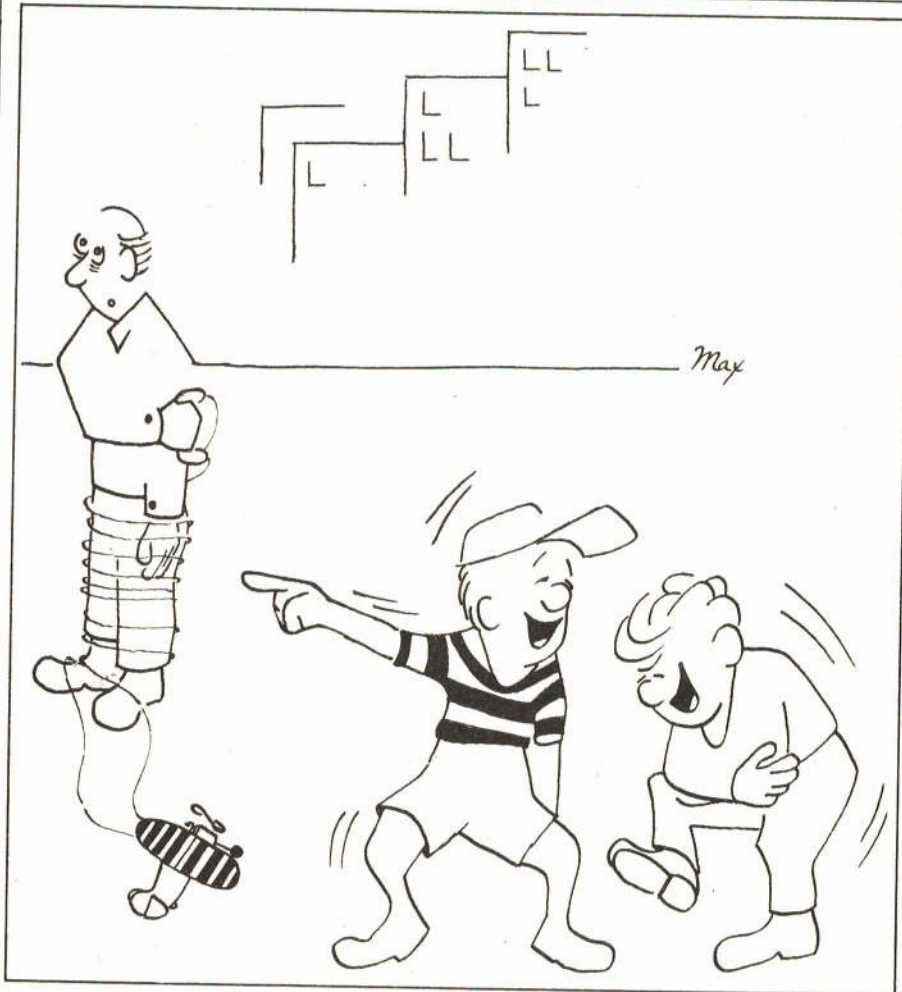

WHAT YOU MISSED!



Catch up. Read Zai's Year Books. Now available, Postpaid:
 1935-36-\$1.50, 1937-\$2.50, 1938-\$3.00, 1951-52-\$3.00, 1953-\$2.00, 1955-56-\$3.00, 1957-58-\$3.00, 1959-61-\$5.00, and 1964-65-\$5.00. Also, MODEL GLIDER DESIGN-\$3.00, CIRCULAR AIRFLOW-\$2.00. Hoffman's BOOK-\$2.00
 Find out what you missed. Order today. Read for ten days. Return for refund if not happy.

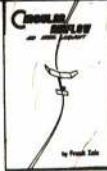

MODEL AERO PUBL • Box 135 NORTHIDGE • CAL. 91324



THE ANTIC

- EASY TO FLY & EXCELLENT FOR TRAINING OR EXHIBITION.
- MAY BE OPERATED FROM SMALL OR ROUGH FIELDS.
- FULL ACROBATIC & CAPABLE OF VERY SPECTACULAR PERFORMANCE WITH THE MINIMUM OF FLYING SKILL.
- MAY BE EASILY CONVERTED TO FLOATS.

NOW ONLY \$59.50



ALSO **PROCTOR** HARDWARE

- RIGGING CABLE
- CONTROL CABLE
- STRUT FITTINGS
- CLEVIS END FITTINGS
- MOLDED HATCH TRIM
- WORKING TURNBUCKLES
- CABLE SWAGE FITTINGS
- MINIATURE NUTS & BOLTS

PROCTOR ENTERPRISES INC.
 P.O. BOX 9641
 SAN DIEGO, CA. 92109

DEALER INQUIRIES INVITED

FOR ALL BEGINNERS, SPORT FLYERS, AND COLLECTORS

6 TO 10 FULL SIZE PLAN SETS PER VOLUME

INTRODUCING **flyin' machine** MAGAZINE

THE FULL SIZE PLANS MAGAZINE / 4 ISSUES A YEAR
 INTRODUCTORY ISSUE ONLY - 1 BUCK
 4 VOLUME SUBSCRIPTION - 3 BUCKS

5424 MAPLE LANE • RIVES JUNCTION • MICHIGAN • 49277



BOX 26263 - Indianapolis, Ind. 46226

SCALE PLASTIC & Balsa MODEL AIRPLANE KITS

Frog - Airfix - Hasegawa - Guillow's - Kayeff

Cleveland Kits, Plans & Printwood

ACCESSORIES & MODELERS SUPPLIES

Imrie/Risley Paints

Badger Air-Brushes

MANY SPECIAL OFFERS

Send 25c for new 28-page catalog #MA-2A

Letraset Decals

Micro Scale Decals

LOWEST PRICES

ZONA SAWS

The One and Only Famous Line of Hobby Saws



Plus six other models to cover a complete range of hobby and craft jobs

\$1.35



MINI MITER BOX \$1.10

AT YOUR DEALER!

F.A.I. Model Supply
 10802 N. 33RD AVENUE
 PHOENIX, ARIZONA 85029

Replacement blades available
MADE IN USA

NEED TUBING OR METAL SHAPES?

LARGEST VARIETY OF SIZES & SHAPES ANYWHERE!



ROUND BRASS TUBE (12")

No.	Size	Price
125	1/16	.15
126	3/32	.20
127	1/8	.20
128	5/32	.25
129	3/16	.25
130	7/32	.30
131	1/4	.30
132	9/32	.35
133	5/16	.40
134	11/32	.40
135	3/8	.40
136	13/32	.50
137	7/16	.55
138	15/32	.60
139	1/2	.65

PLATED SPRING WIRE (12")

192	.032	.05
192	.047	.05
197	.055	.05
199	.063	.05



SHEET METAL (4"x10")

No.	Size	Price
250	.005 Brass	.50
251	.010 Brass	.70
252	.015 Brass	.90
253	.032 Brass	1.75
254	.008 Tin	.45
255	.016 Alu.	.40
256	.035 Alu.	.65
257	.064 Alu.	.90
258	Asst. Brass	.75
259	.025 Copper	1.75



SQUARE BRASS TUBE (12")

150	3/32 Sq.	.30
151	1/8 Sq.	.35
152	5/32 Sq.	.40
153	3/16 Sq.	.45
154	7/32 Sq.	.50
155	1/4 Sq.	.55



BRASS STRIPS (12")

No.	Size	Price
230	.016 x 1/4	.15
231	.016 x 1/2	.20
232	.016 x 1	.30
233	.016 x 3/4	.25
234	.016 x 2	.60
235	.025 x 1/4	.20
236	.025 x 1/2	.25
237	.025 x 1	.50
238	.025 x 3/4	.35
239	.025 x 2	.85
240	.032 x 1/4	.20
241	.032 x 1/2	.30
242	.032 x 1	.60
243	.032 x 3/4	.40
244	.032 x 2	1.10
245	.064 x 1/4	.38
246	.064 x 1/2	.75
247	.064 x 3/4	1.00
248	.064 x 1	1.50



ALUMINUM TUBE (12")

100	1/16	.20
101	3/32	.25
102	1/8	.25
103	5/32	.25
104	3/16	.25
105	7/32	.30
106	1/4	.30
107	9/32	.35

SEND 25¢ FOR CATALOG

AVAILABLE AT YOUR LOCAL HARDWARE, LUMBER YARD, AUTOMOTIVE SUPPLY, OR HOBBY STORE.

ALSO IN STOCK
 MUSIC WIRE, BRASS ROD, ANGLE & CHANNEL.



ENGINEERING CO. 6917 W. 59th ST.
 CHICAGO, ILL. 60638

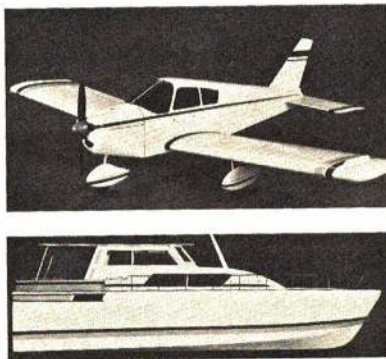

for the faster, easier, more fun way to model...

pro-foam

pro-foam ... rigid polyurethane pro-foam... used by professionals - available now for the hobbyist... try it... for your largest project or smallest detail... a complete model or accessory...



1. cut it
 pro-foam cuts easily with a knife or saw...



2. sand it
 pro-foam sands and shapes quickly... eliminates hours of tedious construction time...



3. glue it
 any popular glue is compatible with pro-foam... ambroid, tit-bond, fealora, eimer's, epoxy...



4. dope it
 apply your favorite covering and finish directly to pro-foam... silk, silk span, tissue, fiber glass...



5. cover it ..
 pro-foam is fuel proof and heat resistant... ideal for heat shrink covering...

STOCK SIZES	P/PIECE	P/PIECE	P/PIECE	P/PIECE	
3 x 4 x 12	.90	3 x 4 x 24	1.80	3 x 4 x 36	2.70
1 x 12 x 12	.90	1 x 12 x 24	1.80	1 x 12 x 36	2.70
2 x 12 x 12	1.80	2 x 12 x 24	3.60	2 x 12 x 36	5.40
6 x 6 x 12	2.70	6 x 6 x 24	5.40	6 x 6 x 36	8.10
6 x 12 x 12	5.40	6 x 12 x 24	10.80	6 x 12 x 36	16.20

if no dealer available - order direct - minimum order \$10.00 plus 10% shipping charge

50¢ for sample and information

MODEL MATERIALS COMPANY - 119 MARIPOSA - WAUKEGAN - ILLINOIS - 60085

CHRISTMAS SPECIAL

Plans and helpful hints for the beginning modeler are featured. Instruction and information are stressed, but the biggest thing is FUN! The magazine is designed for the boy or girl from seven on up. Take advantage of the only model hobby magazine written for beginners.

FATHERS and GRANDFATHERS

Here is **THE** magazine for your son or grandson ! We have planes, cars, rockets, in every issue !

One Year
6 **BIG** issues
only

\$1.10 off newsstand prices

\$2.50

OR

Two Years
12 **GREAT** issues
only

\$1.70 off newsstand prices

\$5.50

USE THE HANDY ENVELOPE TO ORDER!
OFFER EXPIRES DECEMBER 31, 1972



Dr. Wright

TESTORS

Hobby Model Products

ATTENTION . . . SUNDAY FLYERS! THE FOX FALCON 60RC IS FOR YOU

The Fox Falcon 60RC starts easy and runs real steady and reliable. It is very light weight and modestly priced. The Falcon is not intended to win a world's championship, (however we think it could). It is intended to be the simplest, most trouble-free and most forgiving 60 you can fly. It is ideal for beginners and makes an excellent replacement for smaller motors because it weighs only 12 ounces. Fox Falcon is the FUN MOTOR!

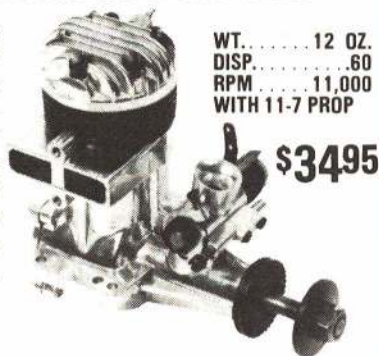

WT. 12 OZ.
DISP.60
RPM 11,000
WITH 11-7 PROP

\$34.95

FOX MFG CO. / 5305 TOWSON • FT. SMITH, ARK. 72901

JUST OUT!

SLEEK AND LOVELY



RYAN ST

KIT NO.109

WINGSPAN 17 IN.
OVERALL LENGTH 12-3/8 IN.
FLYING WGT. APPROX. 7/10 OZ.

2.75

Still as lovely as ever... time can't lessen her beauty. This new addition to the TERN line was designed, as always, with your enjoyment in mind. New design features, top quality kit contents and fly-ability too! OTHER KITS BELOW

Watch this space for more!

GONE GOOSE 17"	Kit No.101...1.50
TRAVELER SAILPLANE 24"	Kit No.102...1.50
STARDUSTER SPORTPLANE 16-1/2"	Kit No.103...1.75
SKIPPER, DIPPER 2in! 11-1/2" & 18"	Kit No.104...2.00
de HAVILLAND TIGER MOTH 17"	Kit No.105...2.50
NIGHTHAWK SPORTSTER 18"	Kit No.106...2.00

SEE YOUR DEALER TODAY. IF UNAVAILABLE ORDER DIRECT. ADD 10% FOR POSTAGE & HANDLING. OUTSIDE U.S. ADD 15%.



TERN AERO CO., inc.
P.O. BOX 66398
CHICAGO, ILL., 60666

MORE NEW PLANES FROM CMI

SPEEDSTER

Speedster 1/2A
"Goodyear Racer"

- ☆ Light and Flexible
- ☆ Fast Construction
- ☆ Full Size Plans
- ☆ Goodyear Racing Rules included
- ☆ Designed by Dean Swift
- ☆ \$3.50

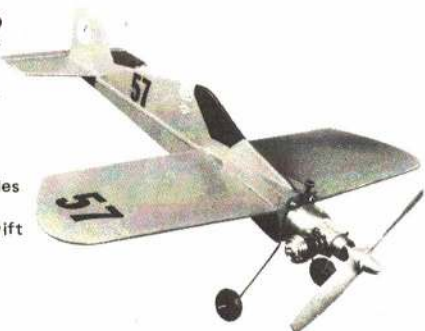

OLD TIMER

Old Timer 1/2A
"Stunt Plane"

- ☆ Designed by Dean Swift
- ☆ 18" wing span
- ☆ Excellent Stunt Trainer
- ☆ Full Size Plans
- ☆ Under Cambered Airfoil
- ☆ AMA Stunt Pattern included
- ☆ \$3.95



RC Guillotine
15 to 23 engines
Kit R103 - \$10.95
(Kit only)

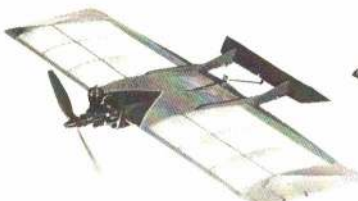

UC 1/2A Guillotine
.049 to .09 engines
Kit C102 - \$3.50
(Kit only)



COMBAT V
UC Guillotine
for 35 engines
\$6.50 (Kit only)
Winner of
8 trophies at the
Nats - Kit C101

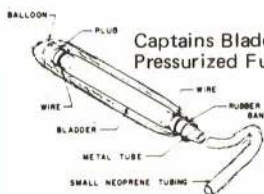

Captains Bladder
Pressurized Fuel Tank 59¢



QUALITY
AIRPLANE KITS

P.O. Box 79 Des Moines, Iowa 50301



The SST

This kit was featured in American Aircraft Modeler Tenderfoot series. This is a very stable easy to fly plane. The kit includes tricycle landing gear for realistic take-offs and landings and Military decals.

R/C MULTI CHANNEL



THE CONTENDER—The first all-balsa R/C model you can build in just 8 hrs. Wing Span: 54" Eng.: .29 to .60. Kit RC-15

\$34.95

KWIK-FLI III... World and twice Nats. winner. Designed by Phil Kraft. Span: 60" Eng.: 45 to 61 Kit RC-12 includes jig for true straight wing.

\$45.00

R/C NOBLER Radio version of the winningest stunt model of all time. Wing Span 51" Eng.: .35 to .45. Kit RC-14

\$29.95

R/C SCALE AND STANDOFF SCALE



S.E.S.a Never before has a R/C scale model been designed with such attention to the most insignificant detail. Wing Span: 52" Eng.: .45 to .60 Kit RC-13

\$47.50

MUSTANG P-51... A standoff scale model that only a ruler can tell from a true scale plane. Wing Span: 60" Eng.: .40 to .60. Kit RC-16

\$45.00

WARHAWK P-40... Now—in answer to your many requests. Span: 60" Eng.: .40 to .60. Kit RC-17

\$49.95

R/C COMPACTS



HEADMASTER... America's best R/C trainer, for up to 3 channels. Span: 48" Eng.: .09-.35 Kit RC-11

\$17.50

TOP DAWG... Single or multi-channel for sport or pylon racing. Span: 39.5" Eng.: .049-.15 Kit RC-10

\$14.95

SCHOOLMASTER... Single or multi channel with rudder, elevator and engine control. Span: 39" Eng.: .049-.090 Kit RC-8

\$9.95

SCHOOLGIRL... Span 32" Eng.: .020-.049 Kit RC-9

\$8.95

SCHOOLBOY... Span: 29" Eng.: .010-.020 Kit RC-3

\$5.50

CONTROL LINE SCALE MODELS

SUPER FORM PREFORMED FUSELAGE SHELLS FOR FAST STURDY CONSTRUCTION



P-40 WARHAWK
Span: 28" Eng.: .15-.29 Kit S-1

\$11.95

P-47 THUNDERBOLT...
Span: 27" Eng.: .15-.29 Kit S-2

\$11.95

P-51D MUSTANG...
Span: 37" Eng.: .29-.35 Kit S-3

\$17.95

SEMI SCALE STUNTERS



HAWKER HURRICANE...
Span: 42" Eng.: .19-.35 Kit S-51

\$8.95

CURTISS P-40 TIGER SHARK
Span: 42" Eng.: .19-.35 Kit S-50

\$8.95

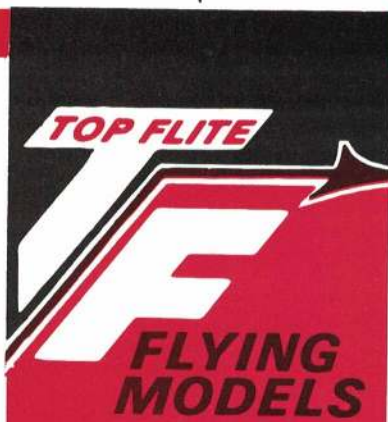

for those
who insist on the
**VERY
BEST!**

1/2 A FORM-FLITES (SCALE U/C)



ZERO... Span: 18" Kit S-20

HELLCAT... Span: 18" Kit S-21

THUNDERBOLT... Span: 18" Kit S-22

\$2.95

CONTROL LINE · STUNT PLANES



REPEATED NATIONALS AND WORLD CHAMP.
NOBLER... Winningest plane of all time. Span: 50" Eng.: .19-.35 Kit N-1

\$15.95



NATIONAL AYSC PLACE WINNER
JUNIOR NOBLER... For expert or novice. Span: 40" Eng.: .15-.25 Kit N6

\$9.50

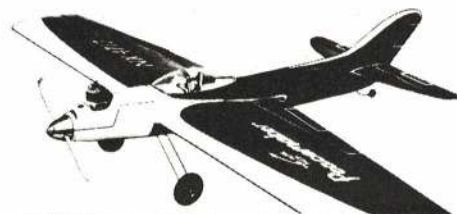

PEACEMAKER... Superform for fast construction, exceptionally durable. Span: 46" Eng.: .15-.29 Kit N-7

\$10.95

FAMOUS FLITE STREAK FAMILY



FLITE STREAK... Combat or stunt flying at terrific speeds. Span: 42" Eng.: .15-.35 Kit N-2

\$7.95

AYSC CHAMPION
JR. FLITE STREAK... Span: 31" Eng.: .15-.25 Kit N-3

\$5.95

BABY FLITE STREAK... Span: 24½" Eng.: .049-.099 Kit N-4

\$3.50

COMBAT STREAK... Span: 42" Eng.: .19-.35 Kit N-5

\$7.95

STREAK TRAINER... Span 33" Eng.: .15-.19 Kit N-10

\$8.95

CONTROL LINE COMBAT MODELS



COMBAT CATS... Two complete models in one box. Span: 39½" Eng.: .19-.35 Kit N-8

\$8.95

(2 models)



COMBAT KITTENS... Span: 22¼" Eng.: .049 Kit N-9

\$5.50

2-models)

TOP FLITE MODELS, INC. 2635 S. WABASH CHICAGO, ILL. 60616

KRAFT SERIES 72
(Continued from page 16)

IF cans and mixer coils (See Figure 1). And the cost is half again as much as the standard six-channel receiver. But if it means that you can fly where you have never flown before, it may be worth the cost.

The transmitter box is about 1/2 inch shorter than previous models. The antenna collapses all the way into the case. The bottom element must be raised and turned two full turns to make electrical contact. There are new stick pots, made by Bourns, which are of much higher resolution than the wire wound ones in earlier models. The encoder is the same, but the RF section is all new. Kraft has gone to tuned inductances and has increased transmitter output to a full half watt.

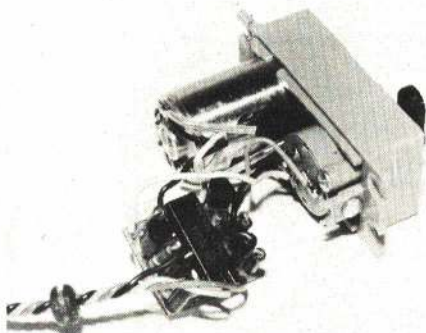

Texas Instruments worked out Kraft-designed amplifier IC with bridge circuit amplifier capable of safe operation at 3.6V.

New batteries, rated at 550 mah are used in both the transmitter and receiver. The charger is designed to charge at a rate of 120-150 ma. This means a full charge can be attained in four to five hours. However, the batteries can be left on charge for 24 hours with no ill effects. The new airborne batteries are compatible with earlier series radios and the manufacturer recommends replacement due to the higher capacity and much higher reliability of the new cells. Older external chargers can be modified to the higher charge rate for the new cells simply by using a different bulb. The new cells can be charged at the old 45 ma rate if you use a full 24 hour charge.

The servos are the biggest news this year. Kraft has gone to a three wire (i.e. 0, +4.8V, and signal) system in the servos. The new servos use a bridge amplifier IC with external output transistors. The bridge amplifier required use of a 10-11 ohm motor. The result is a fast, high-powered, high resolution servo. Servo thrust, depending on mechanics, is from four to six lb. at 3/8". This necessitated a beef-up of the

SUPPORT
AEROSPACE EDUCATION



Model aircraft fabrication/finishing products (Superior to Epoxy)



FABRA-TEX CORP.
P.O. Box 310
Waterville, Ohio 43566
Phone (419) 878-5646



All purpose two part contact glue. Has initial tack & variable set-time which you adjust (10 to 20 min.). Designed for balsa-wood, plywood & plastic.
\$2.95

Jay Lewis Presents...The Hobby Market

SPECIAL
Limited Time Only!!

Buy an EK 6 Ch. Champion ... \$349.95

or

Buy a RCM 800 6-channel ... \$380.00

and

Get your choice of one plane and one motor free!

Pick from below:

- | | |
|------------|-----------------|
| Ugly Stick | Fox 40 R/C |
| Fun Fly | Fox Eagle 60 |
| Lucky Fly | Enya 45 BB |
| Kaos | Enya 60 BB |
| Sr. Falcon | Webra 40 |
| Fledgling | K&B 40 FR or RR |
| P-51 | Veco 50 |
| P-40 | Merco 49 |

Merco 61

Don't pass up this deal
Pro and Beginner alike
SATISFACTION GUARANTEED

Specials: Super Monokote Opaque 3/15.00, transparent 3/16.80, metallic 3/19.50; Solarfilm opaque 3/13.50, transparent 3/15.00, metallic 3/18.00; Super Shoe 2.35; Monokote Iron 10.00; Goldberg Main Retracts 7.95; Goldberg full set 14.75; K&B standard long or short plugs 5.50 per card; K&B R/C plugs 11.25 per card; Fox R/C Plugs 7.95 per card; Dremel tool 27.00; Dremel deluxe home workshop with accessories 40.00; control line kits: Lucky Sport, Flitestreak, Ringmaster, Buster, Shoestring, 3/16.50; Miss Behave, Nobler, Dolphin, Akrobat, 12.00; Midwest ME 109, P-51, Skyraider, P-40, Magician, 8.75; R/C Kits: Super Fun Fly, Lucky Fly, 47.50; Ugly Stick, Kaos, 38.50; P-51 30.00; P-40 33.00; Sr. Falcon 25.00; Falcon 56 14.75; Tigertail 67.95; Windward 18.00; Windfree 23.50; Motors: Fox 35 11.99, 36 11.00, 40 13.25; R/C Motors: Fox Eagle 60 34.00; Enya 45 31.50, 60 43.00; K&B 40 RR or FR 24.00, w/muffler 49.95; Webra 40 43.00, G1 Blackhead 60.00 (plenty of Webra parts), Props by the Doz. 25% off.

Send check or money order to the Hobby Market. Sorry, no C.O.D.'s. Texas residents please add 5% sales tax. Add 30¢ for insurance. Phone (817) 626-1182 after 4:00, or home (817) 731-3174.

PO Box 2172 Ft. Worth, Texas 76101

from *Tatone*



"HINGE IT"
HINGE SLOT CUTTING SET

For All Types of Hinges

- ADJUSTABLE ALUMINUM GUIDE ACCURATELY CENTERS HINGE SLOTS FROM 1/16" to 5/8"
- SPECIALLY SHAPED STAINLESS STEEL KNIFE BLADE CUTS AND GOUGES OUT WOOD FOR HINGES
- KNIFE BLADE FOLLOWS GUIDE, NOT GRAIN IN WOOD, FOR PERFECTLY ALIGNED HINGE SLOTS



only **\$2.95** set

This has to be one of our better ideas. If cutting hinge slots bugs you, give this a try. -Guaranteed to satisfy-

TATONE PRODUCTS 1209 GENEVA AVE. SAN FRANCISCO, CA. 94112

"FLIGHT LINE" AIR WHEELS



NOT SPONGE-NOT PLASTIC, BUT PURE BLACK NEOPRENE RUBBER. WILL NOT CRUMBLE, DETERIORATE OR CUT EASILY

POLISHED SNAP ON HUBS CAPS HIDES AXLE, KEEPS DUST AND DIRT OUT

PUSH ON RETAINER NUT

THICK WALLED, AIR FILLED, LONG LASTING TIRE

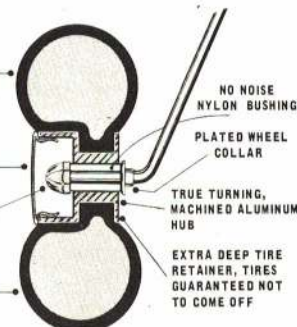

NO NOISE NYLON BUSHING

PLATED WHEEL COLLAR

TRUE TURNING, MACHINED ALUMINUM HUB

EXTRA DEEP TIRE RETAINER, TIRES GUARANTEED NOT TO COME OFF

- LOW BOUNCE NEOPRENE RUBBER
 - TRUE TURNING MACHINED ALUMINUM HUBS
 - POLISHED NICKEL HUB CAPS, HIDDEN AXLES
 - WHEEL RETAINERS AND COLLARS INCLUDED
- 2" DIA.-- \$2.69 pr. 2 1/2" DIA.-- \$2.99 pr.
2 1/4" DIA.-- \$2.79 pr. 2 3/4" DIA.-- \$3.19 pr.
3" DIA.-- \$3.39 pr.

CHRISTMAS CHECKLIST



An exact reproduction of the US War Dept. Official Aircraft Spotters Guide covering profiles and descriptions of 140 Allied and Axis Powers Aircraft. Ranging from Pipers to Heinkels. 160 pages, \$3.95 10x6 1/2.

WWI Aircraft of the Belligerents

- Vol. I Landships, 94 p. \$2.50
- Vol. II Airships, 96 p. \$2.50
- Vol. III Seaplanes & Motors, 96 p. . . . \$2.50

SPECIAL

All 4 Spotters Guides \$10.00

PILOT'S FLIGHT MANUALS

Excellent reprints of official pilots bibles for famous planes.

- Curtiss P-40 Warhawk, 40p. \$2.00
- Curtiss JENNY of 1918, 72p. \$3.00
- Lockheed P-38 Lightning, 72p. \$3.50
- P-47N Thunderbolt, 40p. \$2.50
- F-51D Mustang, 128 p. \$5.95

SPECIAL

All 5 Pilots Manuals \$15.00

- Handbook of Airfoil Sections for Light Aircraft. 144 pages showing 125 popular wing sections. A must for the modeler. \$3.95

PUBLISHERS FIRST EDITION OFFERING

- Guide to Pre-1930 Aircraft Engines. Delightful guidebook to 53 famous engines of the GOLDEN AGE.

Pictures and complete specs. \$3.00

AVIATION PUBLICATIONS

BOX 123

MILWAUKEE, WISCONSIN 53201

Enclosed find \$ _____ Send me the books checked, postpaid.

Money refunded if I am not fully satisfied.

Name _____

Address _____

City _____

State _____ Zip _____

SEND FREE CATALOG

servo mechanics to keep them from self-destructing. The KPS-10 and KPS-11 sport beefed-up pot gears, while the KPS-12 has a domed case top which accepts a longer intermediate gear pin.

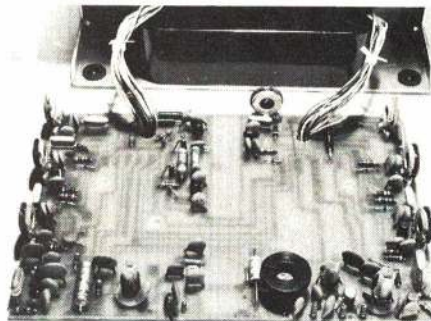

Encoder circuitry has not changed for many years with Kraft sets, but RF section is all new and more powerful.

Neat wiring and lacing with high grade components typical of Kraft sets. Note how antenna collapses into the case.

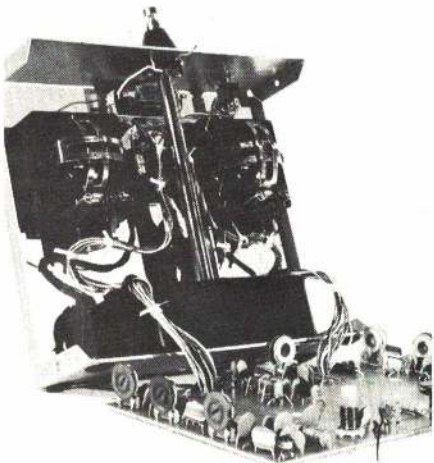

As mentioned earlier, the Series Seventy-one and Series Seventy-two receivers incorporate a high capacitance filter to prevent the transient spikes from the IC servo amplifier from feeding back into the RF section. As a result, the Series Seventy-two servos can only be used with Series Seventy-one or Series Seventy-two receivers and should not be mixed with other vintage servos. Earlier series servos can be used with the Series Seventy-two receiver.

Testing was performed in the usual manner and results are shown in Figure 1, and in the following tabulation. We were unable to secure sufficiently sophisticated test equipment to really wring out the dual conversion receiver, but qualitatively, it appears to meet the published specifications.

Specifications: *Transmitter:* Input power 825 mw at 9.6 vdc. RF output 500 mw. Temperature range 0°-150°F. *Receiver:* Standard—IF frequency 455 kHz, Current drain: 12 ma, Image rejection: -2db, Harmonic rejection: -50db; Dual Conversion—1st conv: 10.7 MHz, 2nd conv: 455 kHz, current drain: 15 ma, Image rejection -60db, Harmonic rejection: -90db. *Both Receivers:* Temperature range: 0°-150°F. Sensitivity: 1.5 to 2.0 uv., Selectivity: 3db down at 3 kHz.

Index to Advertisers

December, 1972

ACE R/C	62, 63
AHM	76
Academy Products, Ltd.	83
Aerotech Model Eng. Co.	95
Alexander, A. Co.	76
Ambroid	66
Associated Electrics	88
Astro Flight, Inc.	87
Aviation Publications	94
Baclmann	69
Boyd, A. B.	72
CMI Quality Kits	91
Cannon Electronics	85
Cleveland Models	72
Collectors Journal, The	83
Cox, L. M.	20
Curtis Dyna-Products	60
D. A. Enterprises	83
Dembros Hobbies, Inc.	77
Diane Publishing	13
Du-Bro Products, Inc.	61
Dumas Products, Inc.	96
EK-logicrol	5
F. A. I.	89
Fabra-Tex Corp.	93
Finley Arts & Crafts	78
Flite Boxes by Inky	74
Flyin' Machine Magazine	89
Fox Mfg. Co.	91
Gee Bee Line	68
Goldberg, Carl	9, 17
Grish Bros.	74
Guillow, Paul K., Inc.	86
Hannan, W. C.	74
Hathaway, John	74
Heath Company	66
Hobby Helpers	68
Hobby Hideaway	87
Hobby Lobby	10, 11
Hobby Market, The	93
Hobby People	6, 7
Hobby Shack	12, 13
Hobby World	82
Indy RC Sales	85
K & S Engineering	89
Kayeff	76
King's RC Dist.	87
Kraft Systems	Cover 3
Larry's Hobby Supplies	67
Lindco	83
MnM Radiomodels	95
Micro-Craft Corp.	82
Midwest Model Products	73, 79
Miniature Aircraft	89
Model Aero Publications	89
Model Materials Co.	89
Model Rectifier Corp.	Cover 4
Nelson Model Products	80
Octura Models	85
Proctor, Lou	89
Pro-Line	95
Quality Hobby Products	87
RC Helicopters	79
RS Systems	75
Randy's Corner	88
Rocket City Specialties	72
Rose Industries	88
Royal Electronics	77
Royal Products	70
Scientific	Cover 2, 3, 59
Shamrock Competition Imports	78
Sig Mfg. Co.	54, 55
Stafford, Jack	68
Stanlon Hobby Shop	71
Sterling Models	46, 47
Su-Pr-Line Products	95
Tatone	93
Tern Aero	91
Testors	91
Texas Models, Unltd.	81
Thermo-Jet Standard, Inc.	74
Tiny Tots	67
Top Flite Models	92, 105
Tower Hobbies	81
Verdell	83
Vetco	72
Williams Bros.	81
World Engines	64, 65
XL-ent Products	66

FOR THE ULTIMATE IN
SCALE
THINK AEROTEC

German WW I Fighter

ALBATROS D-5A

2" to 1' Scale—58-1/4" Span—.60 Disp.



A Custom Crafted Kit only \$89.95

French WW I Fighter

SPAD—XIII

2" to 1' Scale—53-7/16" Span—.60 Disp.



A Custom Crafted Kit only \$69.95

Plans only,	w/Rib & Formers	
Albatros D-5A \$9.95		\$31.95
SPAD-XIII 9.95		29.95
Fokker DR-1 8.95		29.95
Eindecker 8.95		27.95
Beeing P26A 9.95		31.95

All above 2" to 1' Scale

DR 1 Triplane 3" to 1' Scale Plans \$14.95

Special engine & 3 inch accessories available—send for catalog.

TRIAD wood ARF only \$59.95

AEROTEC MODEL ENGINEERING, INC.
Box 116, Lincolndale, N.Y. 10540
(Dealer Inquiries Invited)

Top NATS Winners
"C" Expert
3rd CONSECUTIVE YEAR

PRO LINE RETRACTS TOO!

1st **RON CHIDGEY**
Pro-Line
1971 & 72 Nats

3rd **DON COLEMAN**
Pro-Line
2nd 1971 Nats

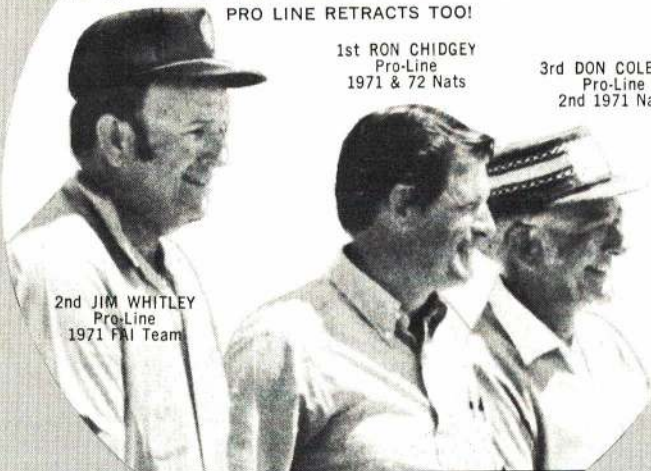

2nd **JIM WHITLEY**
Pro-Line
1971 FAI Team



WRITE
FOR OUR
NEW 1972
CATALOG
FREE!!

P.O. BOX 7733 • PHOENIX, ARIZONA 85011 • TELEPHONE (602) 264-3213



929 S. CEDAR RD.
NEW LENOX, ILL. 60451
R/C PLANES - BOATS - CARS

P.O. BOX 28 - NEW LENOX, ILL. 60451
Phone: (815) 485-2898

NEW R/C DISCOUNT CATALOG .50¢

SPECIAL CUSTOM PROPS

- highest quality maple
- perfectly balanced
- all popular 11" dia. sizes

PRICE: \$ 3.00 each

MOST ORDERS SHIPPED U.P.S. THE DAY RECEIVED

**ADVANCED
PUSH ROD SYSTEMS**

COMPLETE WITH ALL HARDWARE



PLAINFIELD, ILLINOIS 60544

NEW **PROROD** T.M.
THE RIGID PUSH ROD SYSTEM

NEW **MASTEROD** T.M.
THE Flexible Cable PUSH ROD

NYROD®
THE Flexible PUSH ROD

NEW **MASTEROD-XF** T.M.
THE Extra Flexible Cable PUSH ROD

be prepared for the toughest competition or just a lot of fun with these Dumas hi performance R/C and U-control models

HI PRO GLIDER
fiberglass fuselage
101" wingspan \$39.95

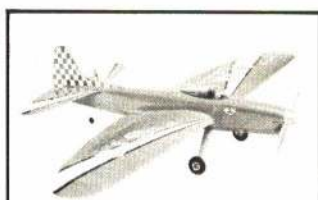

Thunderbird \$19.95

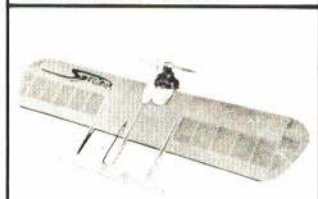

Spectrum \$7.50



Triton \$39.95



THE SMOOTHIE
Contest U-Control
Stunter, 52" span \$15.95

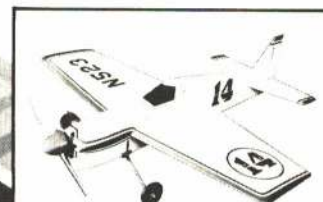

Ole Tiger \$8.95



Evolution 2 \$14.95



Crusader \$13.95

When it comes to contest performance, Dumas RC and Ukie kits deliver. Whether you compete, or just want models that will really give you thrilling action, you'll find the right kit from Dumas. The new HI PRO glider for all purpose soaring using brick or separate 2-channel RC units is easy to fly and has excellent flight and control characteristics. Our famous SMOOTHIE Ukie stunt job . . . excellent contest performance with .35 power, even in windy weather. The THUNDERBIRD Ukie stunt job for .35 engines is a winning beauty. The hot 120 mph SPECTRUM combat ship turns tighter and features rugged spruce tail booms and leading edge doubler, recessed engine and plastic bubble for pacifier fuel tank.

The famous TRITON RC stunt and pattern ship features a 62" foam wing and fiberglass cowl. It's an easy to fly winner with .45 and .60 engines. Everyone is having fun with .15 powered profile pylon racing and many are winning contests with the solid balsa DUMAS OLE TIGER. EVOLUTION 2 is a 1/2 A glider . . . soarer or RC trainer with a 66" wing . . . when you take off the removable wing tip panels you have a great 42" wingspan RC sport ship! Then there's the fantastic CRUSADER profile control line carrier plane . . . she flies fast . . . lands slow, and wins contests. 36" wingspan for .35 engines. Dumas has over 80 model plane and boat kits, send 25¢ for complete catalog.

dumas
planes

Dumas Products, Inc., 790 S. Park Avenue, Tucson, Arizona 85716

Editor:
Carl Wheeley

MODEL AVIATION

Official magazine

A.M.A. NEWS



Academy of Model Aeronautics • 806 Fifteenth Street N.W., Washington, DC 20005

INTERESTED IN JOINING A.M.A.? Over 46,000 did in 1972. Details may be had by requesting FREE BROCHURE from above address.

Executive Council Summer Meeting

The meeting began at 9:20 pm July 26, 1972, in Building 12 of N.A.S. Glenview, Ill. with the following AMA officers present: John Clemens, Dallas, Tex., President; Earl Witt, St. Thomas, Pa., Secretary-Treasurer; John Worth, Washington, D.C., Executive Director; Cliff Piper, Atkinson, N.H. (District I Vice-President); Bill Boss, New Hyde Park, N.Y. (II V.P.); Ron Morgan, Scotland, Pa. (III V.P.); John Patton, Frederick, Md. (IV V.P.); Jim McNeill, Birmingham, Ala. (Dist. V Associate Vice-President, proxy for James Perdue); Glenn Lee, Batavia, Ill. (VI A.V.P., proxy for Al Signorino); Jack Josaitis, Dearborn, Mich. (VII V.P.); Murry Frank, Wichita Falls, Tex. (VIII V.P.); James Finley, Wichita, Kans. (IX, proxy for Stan Clifton); Alex Chisolm, Fresno, Calif. (X. V.P.); Dick Carson, Spokane, Wash. (XI A.V.P., proxy for Bob Stalick). Associate Vice-Presidents also present: Joe D'Amico (II), Josh Titus (II), Frank Morrissey (VII).



Many hundreds of excellent Nats pictures go unpublished each year for lack of space. Here are a few more—by Phil Edwards and the AMA HQ staff. Above: FF Category Champ Bob Watson, Class C Raider 750. Right: Scale Category Champ Tom Stark, Indoor DH 29.

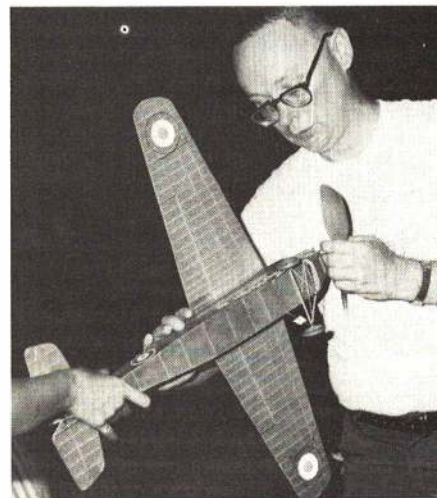

Indoor Category Champ Jim Richmond launched HL Stick model from low level to take most advantage of Cat. II ceiling. Other category champs (pictured in last month's 20 pages of AMA-AAM reporting): Control Line, Glenn Lee; Radio Control, Larry Leonard.

President Clemens then advised that representatives of American Aircraft Modeler Magazine, Ed Sweeney (president) and Joe Wright (promotion manager), were standing by to address the council concerning the agenda item pertaining to AMA's publication plans for the future. Clemens then invited them into the meeting.

Worth introduced Sweeney who then related his interest in continuing with the current AAM-AMA publication arrangement. Sweeney discussed pros and cons of the arrangement and described plans for promotion and growth of AAM. He then introduced Joe Wright to elaborate. Wright told of specific promotions currently underway and others which were contemplated, aimed at reaching new readers and markets which could result in exposure by AMA to potential new members.

After answering some questions from council members, Sweeney and Wright departed. Council discussion then indicated that, since the current magazine contract committed AMA to continuing with AAM during 1973 (1974 would be the earliest practical time for any change), and that any decision would, therefore, not affect the dues situation for next year, the matter of a dues increase should be considered separately from the magazine. It was then agreed to table the magazine subject until after the dues increase question was resolved. The council then pro-

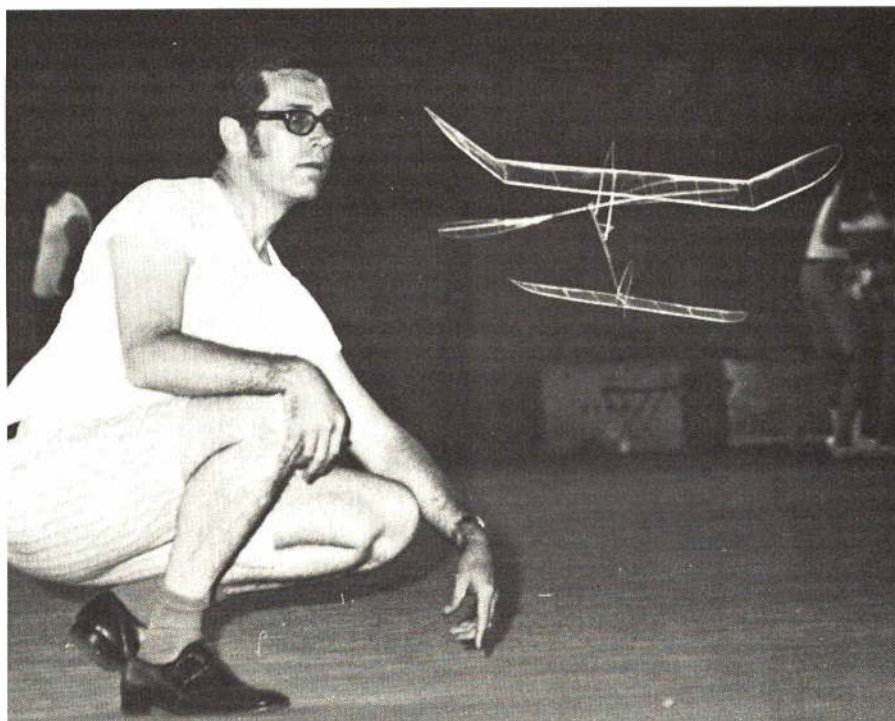



ceeded to consider agenda items in the following order:

Dues Increase for 1973

Since the council previously had agreed (in February) that a dues increase was necessary in 1973, and a quick review by Worth indicated that the need had not changed and in fact was further emphasized by the mid-year AMA financial statement, discussion proceeded immediately to the question of how much of an increase was needed. The range of consideration was established by consensus to be between \$3 and \$10 above the current rate (for Open members).

Carson read a statement from Stalick (Dist. X V.P.) recommending a \$5 increase. Boss concurred. Witt then recommended a flat 50% increase for all age categories. Worth suggested a \$5 increase for Opens, with Juniors and Seniors to be left at \$2, but without any magazine discount. McNeill recommended at least a slight Jr.-Sr. increase, to \$2.50. Further discussion indicated a general consensus in favor of a flat 50% increase, and Piper made a final statement in support.

Finley then questioned AMA's current free Contest Director program in relation to dues considerations. Worth then explained the history of this, including its success in generating activity and contest report response from CD's—in contrast to earlier attempts to penalize or not give credit to CD's for services rendered to AMA. Other council members, particularly Frank, indicated agreement that the current program was working well and should be left as is. There was no further discussion or action on this subject.

Boss then made a motion to increase membership dues by 50% for all age groups; seconded by McNeill. Motion carried unanimously (14 in favor, 0 against).

Contest Board Procedures

Frank related reluctance in his district to accept the previously proposed (Feb. '72) principle of vice-presidents voting in Contest Board matters, rather than CB members. Other council members indicated similarly, and it was noted that several CB chairmen were also opposed.

Frank spoke in favor of leaving the existing voting arrangement as is but changing the cycle of rules action from one to two years, together with mandatory circulation of CB voting actions to V.P.'s for monitoring of district CB member performance. Worth and Morgan supported Frank's recommendations, and Worth noted that they also had the support of CB chairmen.

Boss supported the two-year cycle and principle of CB member voting instead of V.P.'s, but added that previous proposals for simplified CB procedures and a standard proposal form requiring submission by a minimum of two Open members and a Contest Director (as per previous Competition Newsletter descriptions) should be included. It was also noted that the two-year cycle was intended to provide earlier availability each year of a new rule book, with ample advance publication of forthcoming rules changes.

Frank then made a motion to accept all the above in one action to modify existing Contest Board procedures; seconded by Carson and voted unanimously in favor.

Further discussion of other CB procedural details indicated a need to clarify the question



Above: Ernie Violett's veteran Boeing Kaydet won Open CL Scale this year, the result of continuing refinements. Right: Spectators for C Pattern Finals enjoyed seeing scores within an instant after each maneuver. Bernice Williams shown manning the board.



'72 Nats special plaques awarded by the Experimental Aircraft Assn. for best models of homebuilt aircraft. Winners (L-R): Keith Ward, FF Gere Sport Biplane; Ray White, CL Nesmith Cougar (shown); Dick Graham, RC Liberty Sport Biplane. The EAA, like AMA, is a member of the National Aeronautic Association family of sport aviation organizations.



of majority vote, noting a request by CL Chairman Paillet that the definition be changed to prevent unresolved actions caused by previous procedures which did not provide for overcoming a lack of response from some CB members (under those procedures, failure to receive votes from all CB members could result in a 'hung' situation—no action possible even though all those who did respond were in agreement).

The problem was decided to be a lack of provision for a quorum action. McNeill then proposed that CB voting action be on the basis of a 2/3 majority of those responding, rather than the previous requirement of a minimum of 7 in favor; carried unanimously.

Lee then proposed that the first new rule effectivity following the current 'freeze' to be in 1974, by calling for new proposals no later than April 1, 1973, with final voting no later than September 1 on those proposals published to the membership; seconded by Frank. It was noted that this action would not be in accordance with the two-year cycle previously agreed upon, but would be necessary to effect an early transition from the current freeze to the new procedures.

With such a transition the rules freeze would be for two years (1972-73); without it an additional year (1974) would be added—several council members indicated that a two-year freeze was long enough. Lee's motion

Largest Sport Aviation Group

PRESIDENT'S MEMO

We 46,000 members of the Academy of Model Aeronautics are certainly one of the most unique groups of people in the entire world. Coming from all walks of life, we have banded together in the prideful distinction of being the **LARGEST SPORTING AVIATION GROUP IN THE WORLD!** We AMA members represent the United States in international aviation affairs and responsibilities through our being a division of the National Aeronautic Association.

When thinking of international sports one always thinks of the Olympic Games. I have just watched, with mixed emotions, the televised account of the 20th Olympic Games in Munich. While watching the amazing happenings of these Olympics I could never escape thinking of what our sporting aviation body, the Academy of Model Aeronautics, is, what it represents, and what sort of people belong to it. I was pondering these thoughts at the level of our most singular member—perhaps you!

You realize, of course, that we ARE a SPORTING group. We all recognize that as the world becomes more populous and its affairs more complex, more selfish, and more violent—sports and the spirit of sportsmanship have emerged as the primary hope of the world for a common meeting ground for understanding and peace. Sports have been a torch-lit haven from hate and greed, where all men felt they could meet with a feeling of equality. Here, under the banner of sportsmanship, man should be able to engage in innocent and healthful competition—individual, team and national. The winners could be proud, and the defeated re-inspired toward greater future effort.

Unfortunately, during the 20th Olympics, the purity of this idealistic spirit was, in many ways, tarnished. What a terrible waste of this very magic "world catalyst" that is called "sport"!

I am "preaching" on the Olympics because we, too, are a SPORTING GROUP with our sport as a magic catalytic tool we must always be sure we are using properly and to its fullest. I am still fondly remembering the beauty of the international model aviation meetings in Paris last December under the



AMA President John Clemens (L) and ABC-TV's Wide World of Sports commentator Bud Palmer (R), snapped during the 1972 Parachuting World Championships at Tahlequa, Oklahoma. The two were discussing possible TV coverage of AMA aeromodeling activities.

FAI banner. Here were 24 countries sitting side by side and working respectfully with one another toward common goals, with all problems ending in ultimate agreement or acceptable compromise. This was beautiful to see, giving hope for the world's future, and we must be sure we are protecting its magic with our wisdom and actions.

So much for world problems! Now what do sports in general offer us at our local levels? A comradeship of thinking, acting, and understanding—with competition provided if desired. What does OUR sport of MODELING provide? The fascinating challenge of designing and converting various raw materials into aerodynamic shapes and forms that will actually fly through the air, or will perhaps represent larger aircraft in fascinating miniaturized form. This activity automatically creates BETTER EDUCATED, MORE STABLE, and HAPPIER people in our homes and within our communities. Modeling offers something purposeful to do with one's spare time. And it brings together fine people to compound the good. And all this at the very lowest of entertainment cost per hour of enjoyment.

Modeling offers our youngsters an almost

irresistibly exciting way to occupy their time. It helps use up their energies while training their minds and hands and results in a finished product and more fun as a reward. These are the same kids who someday will be running this world of ours! Thank goodness we have an activity like this to offer them. And remember, these kids, too, must learn sportsmanship.

We AMA'ers even see the wisdom of paying dues voluntarily for the privilege of gathering together under this banner of common interest and sportsmanship. True, we 46,000 AMA'ers can't change the world a heck of a lot, but we can at least make sure that WE are conducting ourselves in proper and progressive sportsmanlike ways. We can express ourselves both individually and in club groups to be of benefit to our communities through our pride, learning, sincerity, humility, and integrity—for the rest of the world to watch.

I guess that we 46,000 AMA friends make a pretty good slice of this old world, and I have a fierce pride in being a part of it. Be proud of YOUR PART in AMA.

John Clemens
AMA President

was then voted on and carried unanimously.

Chisolm next moved to have current Contest Boards submit final versions of rule book rewrites by September 1972 to permit early availability of the new book for 1973; seconded by McNeill. Motion carried with 12 in favor, two abstentions (Witt, Finley).

Historical note: after the Nats meeting Boss asked the council to reconsider, by mail, the question of 1974 effectivity of new rules. He noted that such effectivity would delay introduction of the two-year cycle of rules processing by one year and would result in another round of rushed rules processing in 1973. The council response, however, was to retain the 1974 effectivity—six definitely said

no to extending the freeze beyond '74, others simply voted to accept the meeting minutes as originally submitted; none agreed to the extension.

Worth then noted that a long standing problem in connection with safety rulings which require only agreement of the AMA president and the CB chairmen of the appropriate board(s)—past history had shown considerable controversy over some such decisions and that it had been proposed to require Contest Board review of such decisions at the earliest opportunity. The rulings would stand until the review was made, but the Contest Board action would ratify, amend, or otherwise supersede any such safety rulings. Worth

made a motion to approve the proposal; seconded by Morgan and carried unanimously.

Publications

Worth reviewed proposals from Flying Models, Model Airplane News, RC Modeler and noted that American Aircraft Modeler, via the earlier appearance of Ed Sweeney, had offered to continue the current AAM-AMA contract without change from current rates. It was also noted that the current contract requires one year's notice for termination, and that this makes it impractical for any change to be made sooner than 1974.

Carson read a letter from Stalick which



was not in favor of changing magazines. McNeill then spoke against making magazine receipt a matter of optional choice. Frank asked about the possibilities of AMA publishing its own magazine, indicating that this direction would offer the best solution to the problem of which way to go in the future. Worth said that a study had been made by HQ which indicated that this would be a good possibility for the future (particularly if the new dues increase was favorably received and AMA's growth continued) but that at present the amount of money that could be budgeted would result in a lesser product at a higher cost than what members are now receiving.

Historical note: the council had previously (in 1970) considered the possibility of an optional magazine choice but decided against it on the principle that AMA had a responsibility to provide voting members with an official publication, regardless of whether they chose to read it—that this was the only way to assure that each member got notice of official decisions or news.

Further council discussion indicated a consensus in favor of retaining the current magazine, at least until the nature of the membership response to the new dues increase would be known and the effect of various changes and promotional plans by AAM might be de-

termined. Josaitis then made a motion to retain AAM as the official AMA publication, subject to review at the next council meeting or sooner if any new information warrants it. The council voted in favor: 11 for, three abstentions (Piper, Frank, Chisolm).

Worth then presented a proposal for council consideration concerning a new magazine to be produced by the National Aeronautic Association in 1973. The NAA magazine, to be known as National AERONautics, is to be a quarterly version of the sample which was produced by NAA in 1971 as an experimental venture. The magazine would feature all sporting aspects of aviation (parachuting, air racing, ballooning, soaring, etc.) with model aviation (AMA) to have a feature article in each issue.

NAA is to produce three issues in 1973, and copies were offered to AMA at 30 cents each (newsstand price to be \$1.50) if the three issues for 1973 are purchased for all Open members. Discussion indicated several council members strongly in favor, noting that this would be a major PR opportunity for model aviation, would assure recognition of modeling as a co-equal sporting activity with other facets of aviation, and would expand AMA's exposure to new people for potential membership growth.

Morgan moved that the proposal be accepted for one year, in 1973, with evaluation to follow concerning continuance beyond that time; seconded by Finley. The council vote approved acceptance of the proposal as follows: eight in favor, 4 opposed (Witt, Patton, Boss, Piper), two abstentions (Clemens, Frank).

RC Cars

Finley read a letter from Chilton (Dist. IX V.P.) opposing the concept of AMA providing special services (including insurance) to RC car operators. Carson spoke in favor of providing such services, noting that a great potential exists for increase in membership. Frank spoke in favor of leaving the current arrangement as is (insurance coverage provided for RC planes, cars, boats, rocket operation by AMA members). McNeill spoke against any special accommodations. With an obvious consensus not favoring any change, Frank moved that further consideration of the subject be dropped; seconded by McNeill. The council vote was 13 in favor of the motion, with one abstention (Carson).

1973 Nats

Witt initiated discussion by reviewing problems with the 1972 Nats operation, particularly concerning uncertainties resulting from need for many more volunteers than usual—too much effort required of comparatively few so far, and considerable doubt as to numbers available for final cleanup.

McNeill suggested that most contestants were unaware of the magnitude of the problem, and that special announcements or bulletins should be used to get more contestant help. The council consensus was that this should be done, although several indicated strong doubts as to likely success.

Historical note: a special bulletin was produced and circulated during the next two days. Some contestant help did result, particularly concerning workshop hangar cleanup, but the final cleanup was mostly by officials doing an 'above and beyond the call of duty' effort. In the end AMA paid \$600 for final cleanup by off-duty Navy personnel working for two days after the Nats.

Witt recommended that future Nats be based on pre-qualification of contestants, with competition to be of true championships nature, as per the old Plymouth Meets of the fifties, to reduce the size and effort involved in the Nats operation. Much discussion followed on the pros and cons of various forms of Nats possibilities.

Finley then asked for time to present an offer from Wichita (Kansas) interests for future Nats hosting. He distributed copies of letters from Wichita organizations supporting the offer. Further discussion indicated a need for AMA to define its Nats requirements so that such offers could be better evaluated and responded to—it was noted that many years of Navy hosting had clouded the picture concerning what AMA could do on its own or in conjunction with a non-military sponsor.

Frank then moved, seconded by Josaitis, that Nats requirements be defined and published so that bids could be sought from all sources and that the Nats Executive Committee be empowered to act on any offers on behalf of the council; approved unanimously.

Further discussion indicated a desire to have Nats requirements sent to prospective

FAA Advisory Circular

Last month's issue of AAM (page 49) had a reproduction of the Federal Aviation Administration's 'advisory circular' concerning model aircraft flying. AAM and other model press publications rushed the FAA circular into print as a special cooperative effort with the Academy of Model Aeronautics.

As the FAA press release of September 17 indicates, AMA has been involved with this effort "in order to achieve the broadest possible compliance by aircraft modelers." Even though there are many more modelers than there are AMA members, the FAA recognized that AMA leadership extends far beyond its paid membership. The fact, for example, that all magazines are helping is a direct result of AMA communications with the editors.

In addition to magazine publication of the FAA circular, over 46,000 copies went to AMA members. Additional copies are available to anyone (AMA member or not) by requesting same from: AMA HQ, 806 Fifteenth St., N.W., Washington, D.C. 20005.

The text of the FAA September 17 release:

"Recommended operating standards for hobbyists who fly model aircraft have been published by the Federal Aviation Administration of the Department of Transportation to keep them from creating a noise nuisance or a potential hazard to full-scale aircraft.

"The Academy of Model Aeronautics is cooperating with FAA in the program in an effort to achieve the broadest possible compliance by aircraft modelers.

"FAA Administrator John H. Shaffer said the recommended standards are an effort to deal effectively with continuing increases in

model aircraft operations from the standpoints of both safety and noise. "Although the great majority of modelers recognize their responsibilities in these areas, we think the overall record could be further improved through widespread implementation of a few commonsense operating practices," he added.

"Shaffer noted there are an estimated half million people in the U.S. who fly model aircraft as a sport or hobby. The aircraft average up to six feet in wingspan and weigh as much as five or six pounds.

"To assure that the operation of these aircraft does not pose a hazard to other airspace users or create community noise problems, FAA recommends that modelers comply with the following practices:

1. Exercise vigilance for full-scale aircraft to avoid possible collision hazard;
2. Select an operating site far enough from populated areas to avoid noise problems or potential hazard to people on the ground;
3. Limit flights to an altitude of 400 feet above the surface;
4. Operate models at least three miles from an airport, unless prior permission has been granted by an FAA air traffic control facility or the airport manager;
5. Consult the nearest FAA airport control tower or air route traffic control center for any assistance needed in complying with the standards.

"Copies of the free FAA Advisory Circular No. 01-34, "Model Aircraft Operating Standards," are available from the Department of Transportation, Distribution Unit, TAD 484.3 Washington, D.C. 20590.

"The Academy of Model Aeronautics is distributing approximately 47,000 copies of the guidelines to modelers, and additional publicity is being provided for the program in major U.S. modeling magazines."



bidders by September 1st, with bids to be submitted to Nats Executive Committee by November 1st, with the goal of announcing the 1973 Nats time and place before the end of 1972.

McNeill then moved that the Council should thank the Navy, on behalf of the membership and in the form of a resolution, for the 25 years of hosting the Nats; seconded by Carson and carried unanimously.

Historical note: preparation of requirements was delayed by late inputs from the Navy concerning 1972 costs. The goal of '73 Nats announcement prior to January was still retained as of October 1st, but the original timetable for requesting and reviewing bids was no longer possible to meet. Alternative plans were therefore suggested by HQ to make possible a review date of December 1st.

Officer Compensation

Frank initiated discussion by relating his experiences as a vice-president representing AMA, relating to expenses involved. He noted problems when such representation requires an officer to take time off from his normal employment and suggested that this situation, which goes beyond weekend efforts, should receive compensation. Much discussion then followed, most involving variations of a per diem arrangement in connection with expenses incurred.

(Turn to page 102)

FCC Proposal

If adopted Amateur Radio Operators ("hams") will be relieved, when involved in radio control activities, of requirements for station identification, notice of operation away from authorized location, and logging of transmissions.

Responding to a petition (RM-1951) filed by the Academy of Model Aeronautics, the Federal Communications Commission in its Docket No. 19572 said: "We are sympathetic to the petitioner's requests, and we propose amendments incorporating special provisions into the rules exempting certain low power amateur radio stations used only for transmitting signals for the control of remote models of all types. Station identification, logging and portable operation would be simplified. . . ."

AMA's petition compared modeler use of the 50 MHz bands, by holders of licenses in the Amateur Radio Service, with the much simpler requirements for Class C Citizens Radio Service stations in the 27 and 72-76 MHz bands, especially noting that the latter

operators are not burdened with rules calling for station identification, logging and notice of away-from-home operation—despite similar uses.

AMA's petition also sought to relieve concern that transmitted control signals could be interpreted as codes or ciphers which are prohibited by Section 97.117. The FCC was similarly responsive in Docket No. 19572, proposing a new rule specifically stating that such signals are not prohibited.

Included in FCC's proposal are provisions that, to be applicable, transmitters must have a mean output power not exceeding one watt and that an executed Transmitter Identification Card (FCC Form 452-C)—or a durable plate indicating the station call sign and licensee's name and address—must be affixed to the transmitter.

The FCC notice of proposed rule making indicates that AMA's Frequency Committee is continuing to function well on behalf of all RC'ers. It also indicates that the FCC is still responsive to our needs when they are well explained and presented. Credit a new member of the Frequency Committee for most of the legwork on this effort: C. "Torrey" Williams, formerly a member of the Memphis RC Club and now a member of the Northern Virginia RC Club.

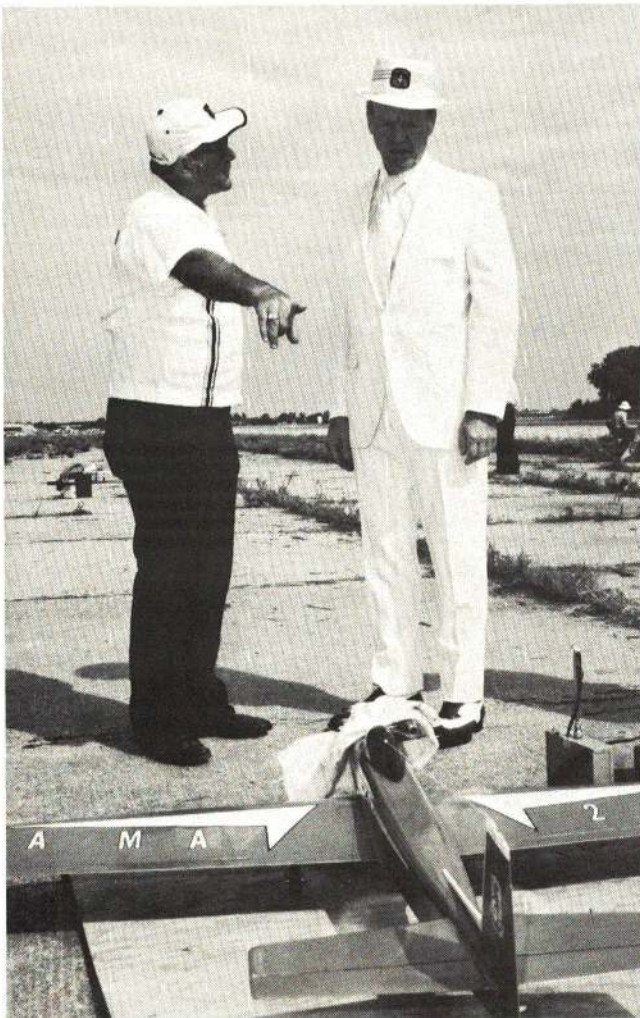

Above: RC Scale Best Flying Achievement Award went to Tom Cook and B-17G powered by four Webra 20's. 78" wingspan, 18 lbs., took a year to build. Left: Famous Commentator/RC'er Paul Harvey (R) at the Pattern event. Joe Bridi points to his Super Kaos. Below: Whit Stockwell (R) was among the strong Formula I flyers who somehow failed to make it to the finals. Father Bob helps; Ed Hotelling watches.





Several council members voiced concern that the subject could easily be misinterpreted by the membership to be a means of salary payment rather than compensation, and that at a time of dues increase, the action would not be well received. This was acknowledged but countered with arguments relating to the need, in order to assure availability and service by those officers who could not otherwise afford the effort; also that AMA already had some forms of compensation (lodging, travel and meals in some situations), and only a broadening of existing policies would be involved.

No consensus was apparent after about an hour of discussion, so it was agreed that the subject would be tabled until the following evening. The meeting adjourned at 1:45 am.

Meeting No. 2 began at 10:15 pm, July 27, same place as the first meeting, with the same attendance except that none of the associate vice-presidents were present (other than those serving as proxies). Witt initiated business on the subject of officer compensation by offering the following motion:

"To partially alleviate the personal financial burden of effectively administering duties of AMA office it is moved that:

"All non-salaried elective officers of the Academy of Model Aeronautics, and such appointive officers as the Executive Council shall designate, will be allowed \$25 per day per diem in addition to travel fare and housing when attending aviation meetings of national or international scope, or trade shows of national or regional scope, wherein the officer receiving such per diem is officially representing the Academy of Model Aeronautics as its spokesman to the sponsoring organization. Excluded from this per diem rate are Academy of Model Aeronautics sponsored and governed events such as the National Model Airplane Championships."

The motion was seconded by Chisolm, then proceeded to discussion. All council

Right: Cary Cain flew Top Flite P-51-D to third in Jr. CL Flying Scale. Below: Jr. CL Rat Race winner/pilot Rodney Lyons (Jim Hainen & Ron Lyons pit crew). Original plane was Supertigre G-21 40 engine.



members participated, with many pros and cons involved, and discussion continued for 40 minutes. At this time the consensus seemed to be that some form of per diem expense type compensation was generally acceptable rather than any form of payment for services rendered, so a vote on the question was called for. The voting result was nine in favor of the motion, three against (Boss, Patton, Piper), two abstentions (Finley, Clemens).

Safety Code

Witt, Worth and Clemens spoke concerning the relationship of AMA's current code to the forthcoming Federal Aviation Administration 'advisory circular' concerning the flying of model aircraft. General council discussion followed, with the consensus that AMA's code need not be changed even if it should not agree exactly with the FAA document. The consensus was that six months of experience with the AMA code (in addition to many previous months of deliberation concerning possible variations) had indicated no safety problems were encountered or anticipated.

The AMA code was praised as an effective

document because it combined relative simplicity without overly restricting activity. The code status was noted to be official and the basis for future insurance coverage, assuming inclusion in the next insurance policy beginning in 1973.

Safety Committee

Witt reviewed the status of the current committee, since his appointment as chairman in February 1972. He indicated that many volunteers had offered to serve on the committee—far too many than he felt could serve effectively. He further stated his intention to have the committee stay relatively small and be concerned with a long range view of AMA safety problems in general rather than specifically concerning various types of model flying activity. Some council members noted that this was a change from the earlier council concept which indicated a preference for representation of various category interests (RC, FF, CL, etc.) on the committee. However, no further discussion or action was pursued.

Control Line Testing

Worth reviewed HQ discussions of recent weeks concerning testing of control lines by commercial testing firms versus tests by modelers. It was noted that even a very elementary commercial test program could be expected to be expensive, particularly if it involved flight testing as was defined as necessary by the previous council meeting in February.

Noting that the object of the testing program was to assure results being accepted by the Control Line fraternity, Worth outlined a suggestion which had been offered by an AMA member (Tom Parry, Audubon, Pa.) who was also an engineer and who was a co-author of articles concerning in-flight tests, during the fifties, which had been well accepted.

The suggestion was to form a committee, composed of various CL proponents identified with differing views, to define an acceptable test procedure. Upon agreement such tests would then be made by several different groups of modelers in different areas of the country. The consensus of test results would then be used as the basis for any rules revisions that might appear necessary.

The council consensus was that this approach was reasonable and should be pursued. Worth was requested to seek a more specific

(Turn to page 104)

Nats Exec. Comm.

Appointment of Kemp Bunting, Munster, Ind., to membership on the Nats Executive Committee, and associate memberships for Jan Sakert, Fountain Valley, Calif., and Dick Carson, Spokane, Wash., has resulted in rounding out this important committee both in numbers and geographical distribution. The committee had been shorthanded since the resignation of Ed Shipe last year and Pete Peters this year.

Others currently serving on the NEC are John Clemens, Dallas, Tex.; Earl Witt, St. Thomas, Pa.; Pete Sotich, Chicago, Ill.; Ron Morgan, Scotland, Pa.; and John Worth, AMA HQ.

The NEC, whose members are appointed by the AMA president, has primary responsibility for National Model Airplane Championships planning. An additional decision the group must make this year, in accordance with authority granted by the Executive Council, is the date and place for the 1973 Nats.

The associate committee member appointments (for Sakert and Carson) are a new idea, to give potential new members a chance to operate within the committee before a final appointment is made. Since NEC membership is for a long range period, compatibility of all members is important, as is the capability of devoting the required time and effort.

New Indoor Comm.

Erwin "Erv" Rodemsky, Danville, Calif., has accepted an appointment by AMA President John Clemens to chair the Indoor Team Selection Program Committee—which has the function of developing the details of how the U.S. 1974 Indoor World Championships Team will be picked. The committee will work within the guidelines detailed in the July 1972 AAM, beginning on page 105.

Rodemsky is a pilot for United Air Lines. He was recommended for the post by the National Free Flight Society; he has long been an active Indoor competitor.

AMA News Extra

1973 U.S. RADIO CONTROL TEAM

A six-round finals at Huntsville, Ala., September 23-24, resulted in the following U.S. team being selected for the 1973 World Championships for radio-controlled aerobatics.

1. Norm Page----Mt. Prospect, Ill.
2. Jim Martin---Bloomfield, N. J.
3. Jim Whitley--Decatur, Alabama

First team alternate is Ron Chidgey, Pensacola, Fla. Team manager is Tom Rankin, Columbia, Md., who was RC team selection administrator for 1970-1972. Thirty-two of the 33 eligible finalists competed. Norm Page led from the first round while Martin and Whitley had last round flight scores which edged out Chidgey and Steve Ellison of Salem, Oregon.

Place position, indicated below, was determined on the basis of totaling the best three flights of each competitor.

1. Norm Page**	22,685	17. Lew Penrod**	20,520
2. Jim Martin***	22,335	18. Steve Helms**	20,505
3. Jim Whitley*	22,065	19. Tony Bonetti**	20,445
4. Ron Chidgey*	21,965	20. William Richards***	19,770
5. Steve Ellison***	21,900	21. Arthur Azlin***	19,755
6. Jim Kirkland**	21,600	22. Jim Oddino***	19,720
7. Phil Kraft*	21,585	23. George Hill***	19,500
8. Dave Brown**	21,535	24. Denis Donohue***	19,295
9. Ralph Brooke**	21,500	25. Henry Walker***	19,220
10. Joe Bridi***	21,080	26. Wayne Abernethy***	19,005
11. Dean Koger***	20,975	27. George Albright***	18,935
12. Don Lowe**	20,880	28. Jim Grier***	18,915
13. Alan Dupler***	20,850	29. Jerry Worth***	18,825
14. Michael Mueller***	20,745	30. Ted White***	18,610
15. Ed Keck***	20,690	31. Don Downing***	16,880
16. Don Coleman**	20,635	32. Cal Scully***	16,780

*1971 team member. **Nats qualifier. ***Point program qualifier.

Steve Ellison, age 18, was among the leaders from the very beginning. He started with a high scoring first flight (equal to Page's 7,030) and continued improving from round to round. But in the end the old pros prevailed. Jim Martin had the highest scored flight of the fifth round, 7,735 points, topping Page's highest flight of 7,650 points. Martin then followed with the third highest score of the meet in the sixth round: 7,635 points. Meanwhile, Whitley came up with his best flight in the last round, 7,505 points, to just nose out Chidgey by only 100 points out of over 21,000.

The team finals meet, known as the RC Masters Tournament, was sponsored by donations from 12 industry firms: American Aircraft Modeler Magazine, E.K. Products, Inc., Flying Models Magazine, Kraft Systems, Inc., Model Airplane News Magazine, Model Rectifier Corp., Northfield Precision--Ross, Pro-Line Electronics, R/C Modeler Magazine, Top Flite Models, Inc., Sig Manufacturing Co., World Engines, Inc. Sponsorship by the industry covered transportation and lodging costs for judges and officials brought from various parts of the U.S.

The meet was part of many programs of the Academy of Model Aeronautics to select U.S. teams to aeromodeling world championships. At the Masters, AMA and RC industry officials joined efforts with an AMA chartered club, the Rocket City Radio Controllers of Huntsville, to host the event.



proposal based on Parry's suggestions, for circulation to the council and a final decision concerning the testing program.

Future U.S. World Championships

Worth recommended submitting a U.S. proposal at the December 1972 annual FAI meeting for possible hosting of a 1974 World Championships for Scale or RC Pylon, or combination of both. Discussion was generally in favor, on the basis that the December offer would not commit AMA and that further details would have to be approved by the council in mid-1973 before a final commitment would be made at the December 1973 FAI meeting. Witt moved, seconded by Boss, that such an offer be made; carried by vote of 13 for, one abstention (Frank).

Public Relations Proposition

A proposal from a Washington, D.C., firm, utilizing the services of a former Navy Public Affairs officer who had worked with AMA on previous Nats programs, was reviewed for possible contract in 1973. Discussion indicated that no decision should be made until after the end of 1972, when the effect of the new dues increase would be known. Frank moved, and Carson seconded, to table the subject until the Winter Council Meeting.

No vote was taken. The consensus of discussion was that between now and the winter meeting the president and the executive director should review AMA's PR needs and make recommendations on the subject to the council concerning next year and the future. Boss added that the recommendations should consider the expansion of Bob Lopshire's efforts.

New Business

FUTURE NATIONALS. Witt repeated his earlier proposal that elimination-type championships be held to reduce the size and effort of the event as compared with past Nats. No action taken since the Nats Executive Committee had already been given the responsibility to make decisions concerning the 1973 Nats.

SOARING ADVISORY COUNCIL. This was proposed by the East Coast Soaring Society, to provide for appointments by district vice-presidents of Soaring representatives to assist RC Contest Board members on any rules actions affecting Sailplanes. Discussion indicated general support for the proposal, although it was noted that Contest Board members have the final voting responsibility—the Soaring representatives would serve to help screen proposals and make recommendations for Contest Board member vote. It was also noted that there was precedent for this action—there had been a Scale Advisory Committee before the activity got its own Contest Board.

Josaitis made a motion to adopt the proposal; Morgan seconded, carried unanimously. Morgan then proposed January 1, 1973, as the effective date; adopted by consensus.

DISTINGUISHED SERVICE AWARDS. Chisolm proposed the League of Silent Flight for its special 1971 rules making effort; seconded by McNeill. Two others were approved, all unanimously; publicity will follow after awards are presented.

FELLOWSHIP. One nomination was made, seconded and approved unanimously. Publicity will follow after presentation.

SCHOLARSHIP PROGRAM STATUS. Worth reported that no awards would be made at the Nats this year, but that awards for 1972 were expected before the end of the year. He noted that the Scholarship Committee now had a new chairman, Bob Stalick, who was working on new criteria for award selection.

CONTEST COORDINATOR REPORT STATUS. This effort, by Boss, was in final stages, with the final draft delivered to HQ. Completion and distribution was expected to be about September 1.

Historical note: the effort by Boss was completed by the end of September, is now being reproduced and circulated to Contest Coordinators for guidance during 1973 and subsequent years.

CONTEST DIRECTOR HANDBOOK STATUS. Worth noted that several previously promised contributions from council members had not yet been received. He said that all the material received to date would be turned over to the project coordinator, Bud Tenny, after the Indoor World Championships, probably in September (Tenny was going to the meet as team manager).

CONTEST						
	1	2	3	4		
7	8	9				13
14	15		18	19	20	
			24	25	26	27
29	30	31				

Official Sanctioned Contests of the Academy of Model Aeronautics

NOV. 4-5—S. EL MONTE, CALIF. (A) S. Calif. RC Air Races. Site: S. El Monte. J. Garabidian CD, 909 N. 3rd St., Montebello, Calif. 90640. Sponsor: San Gabriel Valley RC Club.

NOV. 4-5—RALEIGH, N.C. (A) RCNC Anniversary RC Meet. Site: Raleigh. D. Pearce CD, 1005 Ainsworth Ct., Greensboro, N.C. 27410.

NOV. 4-5—MESQUITE, TEX. (AA) DRC Club Fall RC Ball. Site: Mesquite. L. Hyde CD, 607 Dublin, Richardson, Tex. 75080. Sponsor: Dallas RC Club.

NOV. 5—ABILENE, TEX. (AA) Key City Prop Twisters Fall FF (Cat. II) Meet. Site: Abilene. R. Mayes CD, 2826 S. 39th St., Abilene, Tex. 79605. Sponsor: Key City Prop-Twisters.

NOV. 11-12—TULSA, OKLA. (A) Tulsa Glue Dobbers Fall RC Soaring Meet. Site: Tulsa. D. Nutter CD, 2498 E. 49th St., Tulsa, Okla. 74105. Sponsor: Tulsa Glue Dobbers Club.

NOV. 12—MIAMI, FLA. (AA) Dade Parks & Recreation Dept. Indoor (Cat. I) Contest. Site: Youth Fair Exhibit Hall. R. Myers CD, 3935 SW 125th Ave., Miami, Fla. 33165. Sponsor: M.I.A.M.A. Club.

NOV. 12—SACRAMENTO, CALIF. (A) 12th Annual Stockton Old Timers Contest. Site: Weagell Field. R. Douglas CD 5303 Calderwood Ln., San Jose, Calif. 95118. Sponsor: Oakland Cloud Dusters.

NOV. 18-19—LOS ALAMITOS, CALIF. (AA) All Speed Annual CL Meet. Site: Los Alamitos N.A.S. B. Wisniewski, CD, 4261 Petaluma Ave., Lakewood, Calif. 90713. Sponsor: Speed Flying Anyone.

NOV. 19—ELSINORE, CALIF. (A) "Mini-FAI Champs" Site: Lake Elsinore. M. Keville

PRESIDENT'S AWARD. Clemens reported on a special award he had created and presented at the FAI Free Flight Team Finals last July. He indicated that other such awards would probably follow at other events, such as the RC Masters in September.

LIFE MEMBERSHIPS. McNeill proposed that the letter "L" be prefixed to special AMA numbers for Life members, starting with L-1 and subsequent to existing Life members. Council response indicated a consensus in favor but also a desire to table final action until the Winter Council Meeting. No further action taken. Note: there are currently five Life members this would affect, so the first new Life member would receive number L-6 under this proposal.

APPOINTMENT REVIEWS. Clemens noted that appointments might benefit from prior review and recommendation by the executive director and the president, to help assure that the best qualified people might be selected. No consensus was evident from brief discussion, so the subject was dropped without action.

No further business was offered, so the meeting adjourned at 1:15 am.

CD, 5407 Pimenta Ave., Lakewood, Calif. 90712. Sponsor: Thermal Thumbers.

NOV. 19—TAFT, CALIF. (A) SCAMPS Old Ruler & 30 sec. Antique Meet. Site: Taft. G. Wallock CD, 220 LeRoy Ave., Arcadia, Calif. 91006. Sponsor: SCAMPS.

NOV. 24-26—TUCSON, ARIZ. (AA) Winter RC Nationals. Site: Marana Air Park. R. Angus CD, 6640 N. Columbus, Tucson, Ariz. 85718. Sponsor: Tucson RC Club.

NOV. 26—FRESNO, CALIF. (A) Fresno Monthly FF Meet (Cat. I). Site: Near Kerman. F. Ginder, Jr., CD, 5740 E. Ashlan, Fresno, Calif. 93727. Sponsor: Fresno Gas Model Club.

NOV. 26—VAN NUYS, CALIF. Northrop's 6th Annual "Flying Wing" Contest. Site: Van Nuys Basin. C. Hatrak CD, 3825 W. 144th St., Hawthorne, Calif. 90250. Sponsor: Northrop Model Aircrafters.

NOV. 26—SHARPES, FLA. Spaceport RC'ers RC Scale Meet. Site: Sharpes. G. Jordan CD, P.O. Box 3331, Cocoa, Fla. 32922. Sponsor: Spaceport RC'ers, Inc.

DEC. 3—VAN NUYS, CALIF. N.A.R. Flightmasters 4th Annual "Jumbo Rubber Scale" Meet. Site: Van Nuys Basin. C. Hatrak CD, 3825 W. 144th St., Hawthorne, Calif. 90250. Sponsor: N.A.R. Flightmasters.

DEC. 10—MIAMI, FLA. (AA) Dade Parks & Recreation Dept. Indoor (Cat. I) Contest. Site: Youth Fair Exhibit Hall. R. Myers CD, 3935 SW 125th Ave., Miami, Fla. 33165. Sponsor: M.I.A.M.A. Club.

DEC. 10—ELSINORE, CALIF. (A) Thermal Thumbers Wakefield FF Annual Meet. Site: Lake Elsinore. M. Keville CD, 5407 Pimenta Ave., Lakewood, Calif. 90713. Sponsor: Thermal Thumbers.

DEC. 29-31—JACKSONVILLE, FLA. (AAA) 19th King Orange FF (Cat. II) & CL Internationals. Site: Imeson Airport. J. Wagner CD, 283 E. 8th St., Hialeah, Fla. 33010. Sponsor: Jacksonville Free Flight Team.

DEC. 31—FRESNO, CALIF. (A) Fresno Monthly FF (Cat. I) Meet. Site: Near Kerman. F. Ginder, Jr., CD, 5740 E. Ashlan Ave., Fresno, Calif. 93727. Sponsor: Fresno Gas Model Club.

AMA OFFICER DIRECTORY

The most recent complete directory was published in the August AAM, p. 103.

MONOKOTE GETS LETTERS... LOTS AND LOTS OF LETTERS!

I've never taken the opportunity to thank a manufacturer before, but I do want to express my opinion on your Super Monokote. I've just covered five new wings and stabs with it, and it is great!

Chuck Broadhurst
Sacramento, Calif.

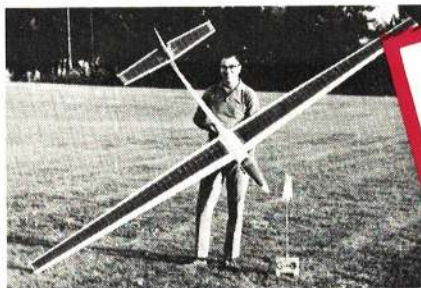

The ship came in 250 ft. straight down in a radio failure and there was only a small tear on the underside of one panel.

Harley
W...

In these days of advertising it's a real pain to get into a product and everything claim

I have not "silked" a Super Monokote because available. My Monokote job was regular silver on an Antic, since then have covered 14 models of my own. 3 Bikes, 1 Tripe & 4 Kwik Fli were included in this total.

Don Johnson
Denver, Colorado

I've been showing it to everyone I know demonstrating how hard it is to damage and the ease with which it can be repaired. Believe me it's all the ad says and more.

Winston Hockenberry
Waterbury Center, Vt.

I have found that Super Monokote works easier than any other covering that I have ever used. Super Monokote surprised me at how smoothly it covers curved areas like wing tips.

Brian McAvo
Greenock, Pa.

MONOKOTE IS THE GREATEST!! I've experimented with most of "them" and always go back to Monokote.

Dan Rhoads
Newington, Conn.

Being a little member...

NOW THERE ARE 16 SUPER MONOKOTE FINISHES

3 NEW COLORS

26" WIDE
 CLEAR PAINTABLE \$1.35 RUNNING FOOT
 CHROME 1.35 RUNNING FOOT
 PLUMB CRAZY 1.75 RUNNING FOOT
 (METALLIC PURPLE)

Oops!

MAKE THAT 18 FINISHES IN ALL!

OLIVE DRAB & DOVE GRAY FOR TRUE-TO-LIFE MILITARY MODELS

\$1.35 RUNNING FOOT

TRIM SHEETS
5" x 36"

CHROME 89¢
 CHECKER BOARDS 1/2" sq. \$1.19
 RED ON WHITE 1.19
 RED ON CLEAR 1.19
 BLACK ON WHITE 1.19
 BLACK ON CLEAR 1.19

5 NEW TRIMS

Gene Rubel
Torrance, Calif.

It's the prettiest finish I've ever had.



Dr. Walter Good
Bethesda, Md.

Even Naomi, my wife, loves Monokote because it is odorless, and also I have been able to stop getting paint all over my clothes. I am sold on this item and intend to trade in all of my paint brushes for a new "iron."

Donald Rothbaum
Silver Spring, Maryland

I'm a fairly new modeler and thought Monokote was too expensive until I saw your ads comparing Silk & Dope costs to Monokote. I tried Monokote . . . and you're right—Monokote's cheaper than Silk & Dope, and holds better too!

Marc Hoit
Michigan City, Ind.

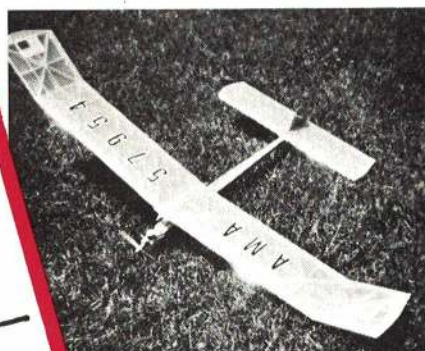

I repaired the damage and recovered with a fresh section of trans-Super Monokote. Only a eye would ever spot the. The good old days of and wait, then steam it again to make adjustments gone forever if Super is used.

Richard A. Lape
Dewitt, Mich.

THESE ARE JUST A FEW OF THE MANY, MANY LETTERS WE RECEIVE EACH MONTH ABOUT SUPER MONOKOTE. TAKE A TIP FROM OUR USERS—SUPER MONOKOTE WILL CUT YOUR COVERING TIME TO A FRACTION AND IT'S MORE ECONOMICAL THAN THE OLD SILK AND DOPE METHOD. IT'S BEEN PROVEN . . . MONOKOTING GETS YOU FLYING, FASTER!

*Pat. No. 3,388,651



TOP FLITE MODELS, INC.
2635 South Wabash Avenue
Chicago, Illinois 60616

CLASSIFIED ADS

Rates: 30¢ per word (including name and address). Minimum—14 words. Send remittance with copy and order to: AMERICAN AIRCRAFT MODELER, 733 Fifteenth St., N. W., Washington, D. C. 20005.

NEW YORK—BUFFALO

Factory authorized Orbit and Micro-Avionics sales-service center. New Orbit and Micro radio systems at very best prices. Complete stock of parts and accessories. Immediate service on all Orbit and 1970 Micro systems. Guaranteed re-conditioned previously owned Orbit systems always available.

ORBIT NORTHEAST

3833 Harlem Rd. 14215 Ph. (716) 836-6860

OHIO—CLEVELAND

We carry the most complete line in Ohio for your model airplane hobby. Also large HO train dept., Boats, R/C, motors, parts, supplies, dope, balsa, tools, books, magazines, etc.

NATIONAL HOBBY, INC.

5238 Ridge Road (216) 749-4750

MASSACHUSETTS—CAMBRIDGE

Model planes, motors, railroads, ships, radio control equipment and accessories—also slot racing supplies. Open 9:00 AM to 5:30 PM daily & Thurs. evenings.

CROSBY'S HOBBY CENTRE

1704 Massachusetts Ave. (617) 547-4389

NEW JERSEY—IRVINGTON

The oldest established hobby shop in New Jersey. Everything in trains, ships, planes and rocketry. Hours 10 to 7 daily, 10 to 1 on Sunday.

THE HOBBY SHOP

758 Springfield Avenue (201) 372-6211

PORTLAND—OREGON

Portland's Headquarters for Radio Control Equipment, all major brands, all at discount prices, "Shop American," "The Friendly Shop."

AMERICAN PET & MODEL AIRPLANE SUPPLY COMPANY

4308 S.E. King Rd. in the Disco Mart shopping center. Ph.: 654-8777 Zip: 97222

SOUTH CAROLINA—BEECH ISLAND

Near Augusta, Georgia. Headquarters for Radio Control Supplies—kits—motors and hard to get items. Building of kits or custom model. Open 9 a.m. till 11 p.m. plus Sundays till 1 p.m.

MILLER'S HOBBY SHOP

315 Laurie Drive (803) 822-0565

COLON, REPUBLIC OF PANAMA

The only hobby shop in the country. Model Planes, Motors (radio controlled), ships, H.O. and N. Gauge trains, complete stock of parts and accessories.

KELNIA S. A.

Front Street, Colon, P.O. Box 2086, Zone 3, Telephone, 47-7040. Warehouse in the Free Zone of Colon.

MICHIGAN—DETROIT (FERDALE)

Trains, planes, stamps, coins, R-ways. Over 50,000 items for hobbyists. Mich. largest antique train collection. Look for our 55' RR crossing sign. Arnold Rapido.

MODELS HOBBY CENTER

22524 Woodward Ave. (Zip 48220) LI-3-2242

GEORGIA—DECATUR

HO Railroads, Planes, Model Car Racing. Open 11 AM to 10 PM. Metro Atlanta's Friendly hobby shop.

HOBBY HOUSE

DECATUR SPEEDWAY

130 E. Ponce de Leon 378-2253

HONG-KONG—KOWLOON

The most complete stock of aeromodeling and hobby supplies in the Far East. Sole agents for Graupner, O.S. and Min-X and agents for Vernon, Frog, Solarbo and many others.

RADAR CO., LTD.

2 Observatory Road Kowloon, Hong Kong K-680-507

ALABAMA—BIRMINGHAM

If it's hobbies, we have it. Most complete line in Southeast. Model airplanes, motors, trains, slot cars, Radio Control equipment—cars, planes, boats and accessories.

SPIVEY DISCOUNT

1303 Tuscaloosa Ave. 205-785-9690

AVONDALE ESTATES, GEORGIA

Southeastern factory repair center for Micro Avionics and Orbit systems. Complete stock of parts. All work guaranteed. Parts in stock for Blue Max and most systems. Authorized factory service center for Testors planes and radios.

HOBBY DISTRIBUTORS

4 Avondale Road, P.O. Box 102, Avondale Estates, Georgia 30002

RHODE ISLAND—PAWTUCKET

Radio Control, Model Planes, Motors, Ships, Rocketry, Arts Crafts, Slot Racing, Parts and Accessories, H.O. & N Gauge Trains, Open 6:30 P.M. to 10:00 P.M. Daily & Saturdays 12:30-5:00 P.M.

R & M HOBBIES

81 Columbus Avenue (Zip 03860) (401)-728-4320

OHIO—JAMESTOWN

Radio Control Specialist. Have done professional building and consultation for research work. Retail stock consists of Radios, Engines, Mufflers, Kits (Arf. & Balsa), R.C. Helicopter Kits, & most support items for R.C. Discount prices. 15 years experience at your service. 6-10 Eve. 10-6 Sat.

MID-OHIO RADIO CONTROL

3949 North Lake Shore Drive 513-675-2613

VIRGINIA—ARLINGTON

Washington D.C. Area? Try us First! Model aircraft, R/C, U/C, F/F., R/C Cars, boats, engines, accessories, equipment, publications, tools, unimat lathes and parts. Hours: Mon, Thurs, Fri: 10-9, Tues and Sat: 10-6.

ARLINGTON HOBBY CRAFTERS

625 N. Glebe Rd., Arlington, Va. 22203 522-6442

SOUTH CAROLINA—NEAR BOWMAN

Located on Road 36 just off I-26. Complete U-Control Center on 12-acre flying field. Big Discounts! Open 4 to 8 weekdays and all day Saturdays. Plenty of help for beginners. Flying every Sunday afternoon.

ACTION HOBBIES MODEL AIRPORT

Route #1, Box 63AB Bowman, S.C. 29018

MEXICO—MEXICO CITY

The most complete stock of aeromodeling and Radio Control supplies in Mexican Republic. Factory authorized Kraft System, Pro Line System, Webra and H.P. Engines.

Sales and Service center, all best items and the best prices.

We accept Bancomatic & Bancomer Cards.

MATHELIN MODELISMO

Retorno 3 DeGral. Ignacio Zaragoza No. 47 Mexico 9, D.F. Tel: 5-71-75-07

WEST VIRGINIA—PARKERSBURG

Planes-R/C and Control Line. Engines and Accessories. All kinds of Goodies! Kraft Radios, Sig Products, Lionel Trains. Also HO and N gauge trains and accessories. HO slot track in store. HO slot cars and parts. Craft and Hobby supplies.

WILSON HOBBY SHOP

Park Shopping Center, Parkersburg, W.Va. 26101 1-304-428-0713

COLORADO—COLORADO SPRINGS

Complete line of U-Control, Free Flight and Engines. Headquarters for R/C. We feature Royal Classic, Lee Engines, Sig Products. Master Charge. Discount to AMA Members. "We Fly What We Sell"

CUSTOM HOBBIES

2408 E. Platte Ave., Colorado Springs, Colo. 80909. (303) 634-7400

QUALITY HOBBY SHOPS

Quality Hobby Shop spaces are sold on a six-month basis at \$7.00 per month, payable in advance. All insertions must be consecutive. No mention of mail-order business is permitted. Closing Date: 10th of third preceding month.

COLORADO #64 RUBBER BANDS, ¼ lb. post paid \$1.00. Red, blue, yellow, black, white, tan. MEISTER, 711 Main St., Keokuk, Iowa 52632.

CUSTOM BUILT Precision geared 12 volt unit. Fused and details very fast. Written guarantee. Send 10¢ for brochure. CALEM ENTERPRISES, Box 38, Goldens Bridge, N.Y. 10526.

SUPER BUCCANEER BY BERKELEY. 4 blueprinted sheets, exact full-scale reproductions of original plans. Shipped in mailing tube \$7.95 set ppd. The CALICO CAT, 121 North Center, Statesville, N.C. 28677.

BUILD A 2-STAGE RUBBER BAND MOTOR with this amazing device. First stage—high power. Second stage—low power. With plans \$1.50. AL CAIN PLANS, INC. 3022 Chapel Hill Rd., #37-A, Durham, N.C. 27707.

OKIE BIRD. ½-A Free Flight Contest Winner. Kit only \$6.00 postpaid. CLEMCRRAFT, P.O. Box 524, Sand Springs, Okla. 74063.

SCALE R/C PLANS.

GRUMMAN TBF-1C* 1¼" scale, wingspan 60¼"
GRUMMAN F6F-5 HELLCAT* 1¼" scale, wingspan 53¼"

RYAN FR-1 FIREBALL* 1½" scale, wingspan 60"
BOEING P4B-4 1¼" scale, wingspan 52½"
GLEE BEE R-1, 1932 PYLON RACER 2" scale, wingspan 50"

Full size scale plans, two sheets 36"x54" \$5.50 per set. *Scaled from measurements on actual aircraft. Send 20¢ for brochure. AER-O-SCALE, PO Box 3413, Granada Hills, Calif. 91344.

INDOOR KITS AND SUPPLIES. Microfilm solution, condenser paper, nichrome wire, indoor balsa, flying scale and peanut scale kits and plans. Send 25¢ for catalog. MICRO-X PRODUCTS, 5200 Seven Pines Drive, Lorain, Ohio 44053.

R/C EQUIPMENT SALE. Stamp for catalog: J-F ELECTRONICS, 314 South 13th Avenue, Yakima, Washington 98902.

ELECTRIC FLIGHT IS HERE—ALPHA POWER UNIT \$24.95 motor, prop, battery, recharger. FLIES R.C., F/F PLANES. MICROCONTROL \$12.95. MOTOR CONTROL WITH ANY RUDDER ONLY PROPORTIONAL SYSTEM. SOLID STATE F/F TIMER \$11.00. Send \$1.00 postage, handling. Everything completely assembled. FREE plane plans, information. Dealers welcomed. GALLER ELECTRONICS INDUSTRIES, Box 87, South Walpole, Massachusetts 02071.

CHRISTMAS SPECIALS: SuperTigres: G 15 FI \$20.75, G15/19 FI \$20.75, 23 RC \$19.95, G 21/35 \$20.75, 40 RC \$23.95, 51 RC \$30.75, G65 RV ABC \$44.75, Max 15 RC \$15.95. Most Tigre and Max engines in stock. Complete line of World Engines digital systems at super discount prices. Blue Max 6 channel assembled regular \$340.00, your cost \$249.95 postpaid and insured. DON'S SALES & SERVICE, P.O. Box 224, Fort Thomas, Kentucky 41075.

WANTED: 1, 2 channel radio sets, MATTHEW ORESKY, 28 Orton Dr., E. Northport, N.Y. 11731.

DIESELS FOR SALE: Reasonable prices—over 100. Send for list. EMILIO FINATO, 38022 Glendale Dr., Fremont, Calif. 94536.

WANTED: Cleveland Kits, plans, printwood, original boxes. JERRY ANTZAK, 7506 Sussex Drive, Plymouth, Michigan 48170.

BIG SAVINGS! Complete line of R/C and U/C accessories. Rev-up props 7/4 to 14/6. Cox S.T., O.S., Fox, K&B engines in stock. K&B Schn. 15 R/C \$24.95, O. S. 25 R/C \$19.95, Fox 36X \$12.95, Dubro Sea Bird \$42.95, Andrews H-Ray \$16.95, Goldberg Shoe-string \$8.95, Devoon 2½ oz. \$1.89. Just a sample. Many kits, engines and accessories in stock. Send for free price list. B&N HOBBY CENTER, 5200 Rye Drive, Dayton, Ohio 45424.

EK LOGITROL. Complete 4 channel system. Excellent condition. Recent factory tune up. \$195.00. BILLY SMITH, 1750 Sylvan Drive, Montgomery, Ala. 36106.

WORLD WAR II R/C SCALE 6¼" P-47D Plan \$5.95 or complete kit \$64.95 with detailed cockpit as used in my 2nd place 1970 Nats model. 62½" Douglas Skyraider plan \$5.95 with detailed cockpit as used in my first place 1972 Nats model. BUD NOSEN, Box 105A, Two Harbors, Minnesota 55616.

CURTISS HAWK P6E, Plans & Construction Manual, 2" Scale \$8.50 P.P.D. 1-½" Scale, \$6.50 P.P.D. CURTISS GOSHAWK F11C-2, Plans and Const. manual, 2" Scale only, \$8.50 P.P.D. BARRON'S ENTERPRISES, 1213 Holly Spring Lane, Grand Blanc, Michigan 48439.

WANTED: Ignition Engines: Torpedo 24 and 29, ARDEN 09 and 19, FOX 49 and 59, ATOM 09, OHLSSON Gold Seal, ORWICK 23 and 29, Pace-maker 59; Aero 35 Glo; Electronite coils. ROLF O. NORSTOG, 11285 W. Kentucky Drive, Lakewood, Colorado 80226.

DIRIGIBLE Bu'd and fly 12' long remote controlled airship. Plans and book \$5.25. LTA Products, 15-A William Street, Closter, New Jersey 07624.

HAND CUT KITS: Beautiful Velle Monocoupe, rubber powered \$7.95, plans \$2.25. The J5 Club, ¼A R/C or F/F Kit \$14.95, plans \$3.00. Stamped envelope brings photo sheets from Flyline Models, 10643, Ashby Place, Fairfax, Va. 22030.

SCALE R/C Plans—59¼" Bucker Jungmeister \$4.95, 57" Tiger Moth \$5.95, 63" Mosquito \$5.95, 69" Douglas Dauntless \$7.50, 56" Spitfire \$4.50, 60" Stuka \$5.95, 60½" Fairey Swordfish \$5.95, 60" Hurricane \$5.95, 72" Beaver \$5.95, 60" Avro Vulcan Delta \$6.95, 62" Zero \$5.95. Canopies, Fibreglass cowls, etc. Available as well as complete kits. Write for free list or send 25¢ for illustrated catalog. BUD NOSEN, Box 105A, Two Harbors, Minnesota 55616.

CUTTING TOOLS. Precision tools, mills, reamers, dial calipers, more. Catalog 25¢. RED, WHITE & BLUE Company, Box 654, Flagstaff, Arizona 86001

SERVICE

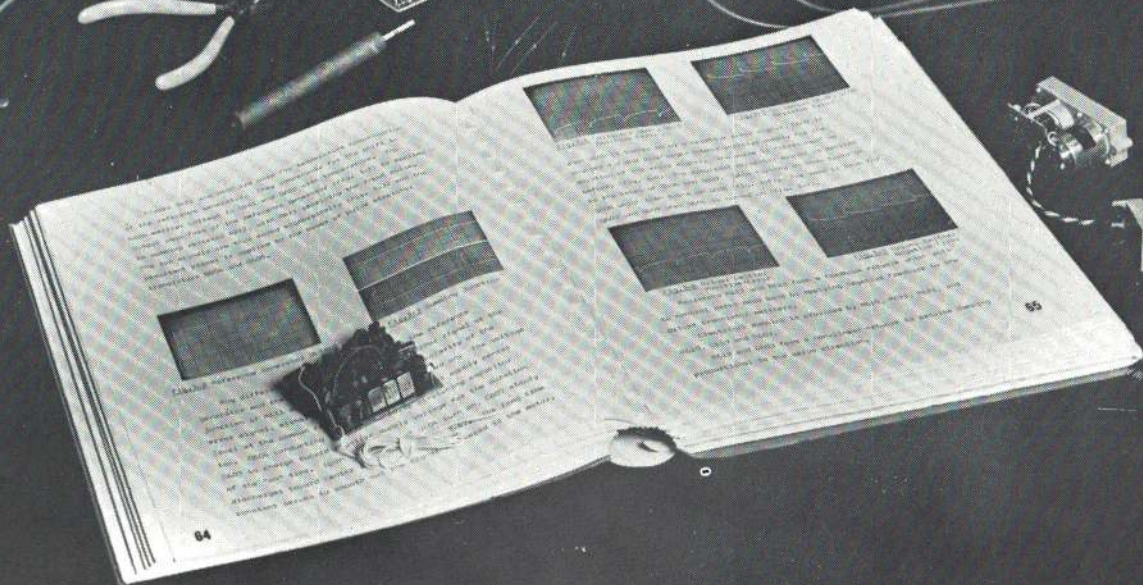
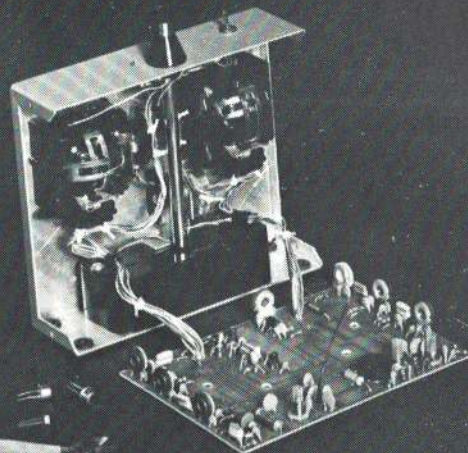
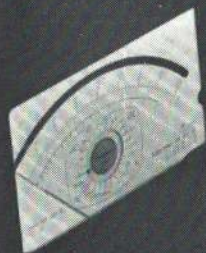

The comprehensive 180-page service manual pictured above covers all Kraft equipment manufactured since 1967. It is an invaluable tool for our worldwide network of authorized service stations. Surprisingly, other R/C manufacturers do not offer such a service manual, but . . . others do not emphasize service as we do.

WRITE FOR FREE CATALOG



450 WEST CALIFORNIA AVENUE, VISTA, CALIFORNIA 92083
World's Largest Manufacturers of Proportional R/C Equipment

● the turning point

MRC-KAVAN All New Electric Starter

- Only 1¾" in diameter.
- A high torque planetary gear system that greatly reduces overall size and lines up the starter hub and engine crankshaft with your hand for non-stalling effortless starts.
- No-slip tongue and groove, replaceable drive hub. One end for large spinners, the other for prop nuts and small spinners.
- No electrical on-off switch to wear out. The actuator button raises and lowers the motor brushes for go—no go.
- Long lasting gears in the high-speed drivetrain—where it counts.
- Built-in V-groove and included drive belt for starting boat engines. (Helicopters, too).
- Standard 12 Volt battery operation. For small motors, 6 Volts will do.

Ushering in a new era in power and versatility . . . the MRC-Kavan starter signals the end of hard-to-handle, ill-powered, toy-like mechanisms, and marks the turning point in starting engines.

Now for the first time, you can buy a starter designed from the hub up to start model engines . . . from the smallest to a flooded sixty without a whimper. Check these features and we think you will see why the new MRC-Kavan starter stands head and shoulders above anything that has been previously offered.

There's one other thing that we can assure you of . . . the new MRC-Kavan electric starter will set some kind of record for "times borrowed" at the flying field. Stop in at your hobby dealer and take a close look at one. We think you'll agree it's something that will turn you on.

