

JANUARY 1950 • 25 CENTS

# MODEL AIRPLANE NEWS





stalling 200 hp engines to replace the 125's used to date. Piper is also turning the engines around to the tractor position, which necessitates a slight relocation of the wing. Cagney Bill Piper has experimented with numerous lightplane designs, notably the *Skysedan* and the *Skycycle* (MODEL AIRPLANE NEWS, November, 1945, issue), but none of these seemed to fit his own mass-production market. With the shift definitely away from the two-seater and to the four and six-seat executive-type light transports, Piper may have his eye on the future.

NOW IT'S THE supersonic Lockheed XF-90 fighter and the word seems to be growing progressively commonplace. Lockheed test pilot "Tony" LeVier recently streaked across the Muroc desert at better than Mach one in level flight in the needle-nosed speedster. The swept-wing penetration fighter is powered by two Westinghouse J-34 turbojet engines with afterburners, a total of about 12,000-lb. of thrust. Air Force has definitely decided on the F-90 over the McDonnell XF-88 and Republic XF-91 swept-wing fighters and a small production order is expected shortly. Meanwhile, Air Force pilots have taken over the testing of the XF-91 in its Phase II flight test program.

THE LIGHTPLANE industry may soon have "a prototype bill" of its own if CAA Administrator Delos Rantzel's plans materialize. Veteran airplane designer Fred Weick, now director of personal plane research at Texas A & M College, has completed plans for a new-type aerial spraying airplane especially tailored for the job and Rantzel believes that the airplane has such economic importance that he has interested the U.S. Department of Agriculture in a joint program for its development. Rantzel's plan is to let construction of the airplane out on a competitive bid basis for a few prototypes. The CAA and Department of Agriculture would pay the manufacturer his costs for this small quantity. Mass-production of the airplane would be up to anybody interested, probably the

DEVELOPMENT of the first true jet transport by the British—the famed DeHavilland *Comet*, will shortly produce tangible reaction on this side of the Atlantic. Immediate reaction by Congressional and industry leaders was one of dark pessimism for the U.S. transport picture. This was followed a few weeks later by a series of "So what?" type of quotations by leading airline and aircraft manufacturing executives. Latest development, however, is the actual "go ahead" given by three different companies to their technical and experimental departments for a prototype airplane from designs completed more than a year ago. The industry has waited quietly while Congress debated the so-called "Prototype Bill," which would provide government money for the development of experimental transports useful both to the commercial airlines and to the military. The bill failed to get action last year, and this year, after desultory discussion, again failed to come up for action. The industry apparently has taken this as a firm, if not final, default of the idea and is, therefore, going ahead with its own money. Douglas, Lockheed, and Boeing have decided to take the plunge. Convair will await the outcome of tests of a jet-powered Convair *Liner* now being modified. Boeing has completed plans for a commercial version of its famed

XB-47 swept-wing jet bomber. The Boeing *Jettliner* will be powered by four turbojet engines suspended in twin pods at the wing-tips and huge external fuel tanks at the inboard position. Glenn L. Martin wants frantically to get into the race but its financial situation makes it touch-and-go at the moment. So, standby for the parade of U.S. jet transports—it will be starting soon.

IT IS now clear that the North American F86-A *Sabre* swept-wing jet fighter is a sonic speed airplane. The attainment of sonic speed in dives was reported more than a year ago. Recently Marine Lieut. Col. Marion E. Carl dove an F-86A to Mach number 1.05 over Wright Field, Dayton, Ohio. Slide rules are still clicking over the performance of the two F-86A's in the 1949 National Air Races. On one lap a speed of 635 mph was hung up but the slide rule artists say this was calculated on the basis of the 15-mile course and not on the actual 18 miles the airplane flew to cover the course! On this latter basis the swept-wing speedster was hitting supersonic speed in full view of about 50,000 spectators!

IT'S NOW THE Piper *Brigadier*, the designs of the twin-engine pusher light transport having been transferred by the Baumann company a few weeks ago. Piper is not talking about his plans for the airplane, other than the fact that he is in-

(Turn to page 54)

## CONVENIENT ORDER BLANK

### EVERYTHING

in this magazine  
can be ordered  
from AHC

★ ★ ★ ★ ★

#### WHAT OTHER HOBBY STORE GIVES YOU:

1. FREE one year subscriptions to *Model Airplane News*, *Air Trails* and *Flying Models* to our regular customers.
2. 14-Day Money Back guarantee on unused purchases.
3. Unused purchases exchangeable.
4. No postage or packing charges—we insure safe delivery.
5. 24 Hour service. New York, Chicago and San Francisco addresses to serve you faster. If it's advertised, we can supply it.
6. Most complete model stock in America—gas, rubber, solid, etc., etc.
7. Competent understanding of your modeling problems.
8. No "minimum" orders. Any order is welcome.
9. FREE Coil, condenser, etc., etc., with gas motors. 50 ITEMS WORTH OVER \$7.00 AT NO EXTRA COST.
10. FREE rubber wheels, knife, etc., etc., with every gas plane. 12 ITEMS WORTH \$3.50 AT NO EXTRA COST.
11. FREE membership in "Modelcrafters of America", the club that keeps you up to date on gas modeling and SAVES YOU MONEY ON YOUR PURCHASES.
12. FREE illustrated giant 2-color 64 page catalog with every order.

?????

AHC does!!

#### HOW TO ORDER

Send remittance in full (we prepay packing and insure) or send \$1 and we ship collect C. O. D. same day for balance. Address your orders to us at your nearest branch office.

### America's Hobby Center INC

Please RUSH me the followings

Name \_\_\_\_\_

Street Address \_\_\_\_\_

City \_\_\_\_\_

Dept. MC-10 156 West 22nd St.  
New York 11, New York

Dept. MC-10 55 E. Washington St.  
Chicago 2, Illinois

Dept. MC-10 Suite 230-742 Market St.  
San Francisco 27, California

Amount Enclosed \$ \_\_\_\_\_

Zone \_\_\_\_\_ State \_\_\_\_\_

Page	Quantity	Name & Description of Items	Cost Each	Total
				<b>Total</b>

24 HOUR SERVICE AT ALL TIMES

America's Hobby Center INC

A GENERATION OF FAIR DEALING GUARANTEES YOUR SATISFACTION

## Ray Acord's NEW

# "CHAMPION"

ANOTHER WINNING  
WEST COAST DESIGN

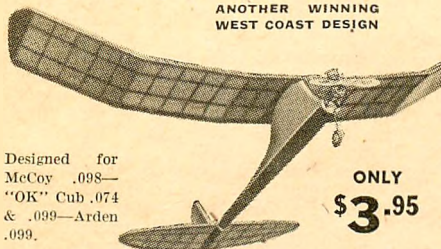

Designed for  
McCoy .098—  
"OK" Cub .074  
& .099—Arden  
.099.

ONLY  
\$3.95

The "Champion" is the result of years of contest building and flying. It has every top feature needed to give (1)—fastest building time (2)—accurate, sturdy construction (3)—long, consistent thermal flying. "I believe this new, simple fuselage construction to be the best and fastest I have yet seen."—Ray Acord.

### NEW "TINY" STEEL MOUNTS!

Can't get along without these for the McCoy .09 and "OK" Cub. Only 25¢ the pair. Save yourself dollars in time! Save years in temper! Ask for Med. (Class A&B) 35¢ pr. Ask for Lg. (Class C&D) 35¢ pr.

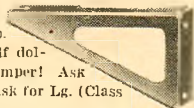

## ZEEK

### SWEEPING THE COUNTRY WINNING CONTESTS

The most complete pre-fab free flight kit ever offered. Extra quality throughout. Complete with Air-O Props, Air-O Steel Engine Mounts, die-cut ribs, shaped trailing edges, shaped fuselage sides, rudder, pylon.



ONLY  
\$4.95

Designed for Use with  
Ohlsson 19 or 23 Mc-  
Coy .19—Arden .19

## CONTESTOR

Rotary or  
Side Port

A rugged champ that can't be beat. Run ignition or glo plug. Proved performance. Proved dependability. A piston ring engine that'll still be running when others are junked, worn out. A \$28.50 original for

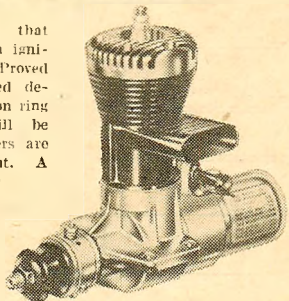

ONLY  
\$11.95

## AIR-O PROPS

Used by  
the Experts

NOW: a new, specially designed prop for the McCoy .098 and the "OK" Cub .074 & .099. (7 1/4" dia.) 35¢ each.



\*Holds more free flight records than all other makes combined. Used by the last three Nat'l champs: Frank Cummings, Bob Holland, Ray Acord.

Order Direct only if Dealer Out.

air-o  
Model Supply Company

741 NORTH PRAIRIE AVENUE  
HAWTHORNE CALIFORNIA

# REPORT FROM THE WEST

by Lew Mahieu

THE West Coast has been favored with some fine contests this past month and also has regained some of the speed records which were held by Easterners. So once again the West Coast holds the majority (jet excepted) of the speed records. We shall first tell you the outcome of the Western Open Contest and then the results of the Las Vegas U-Control Meet, followed by a few words about some personalities.

With only two weeks' notice, the contestants still showed up to make the Fourth Annual Western Open a big success. Frank Cummings, Contest Director, had only a month's notice on the Meet and here we want to add that Frank deserves a big pat-on-the-back for doing such a fine job running the Meet, and almost singlehanded at that! There were approximately 350 entries in the six events. The Los Angeles Junior Chamber of Commerce sponsored the Meet, with Mobilgas donating the fine trophies this year. Frank tells us that the plans are under way for the 5th Annual Western Open next year and that it is to be the biggest and best one yet. The Sweepstakes winner of this year's Meet was Don Donahue who won the same award last year. Don placed first in outdoor rubber and second in indoor rubber to total the most points. The contestants were glad to see a sponsor this year so that they would not have to absorb the cost of the Meet with an inflationary entry fee, as was the case at the 1948 Western Open. This year a contestant paid one dollar to enter both Indoor events, one dollar to enter both Free Flight events and one dollar to enter both U-Control events. (Yours truly recalls a hole in his pocketbook last year of \$7.50 for entry fee.)

Contestants drove for hundreds of miles to attend the Meet. A large group showed up from the Oakland and San Francisco areas. We also saw contestants and spectators from Arizona and Utah.

Saturday, October 1, 1949, the Indoor events were run off at the Santa Ana blimp hangar and the U-Control events were run off at Western and Rosecrans in Los Angeles. The results were as follows. *Indoor Rubber Open*—Bill Tharp 25:07; Don Donahue 23:26.4; Warren Williams 23:06.5; Sr.—Leon Morris 14:59.1; David Baker 14:59; Bill Poesh 4:33.4; Jr.—Gene Wallock 4:38.5; *Indoor Hand-Launch Glider Open*—Carl Rambo 1:06.8; Bob Moncrief 1:06.4; Bob Dagan 1:04.1; Sr.—Charles Hul-lam 1:00.6; Angelo Lo Castro :56.2; Jack Butler :55.2; Jr.—Robert Isaacson :46; Gene Wallock :37; Gary Heathold :28.5; *Novice*—Joel Petersen :35.1; Cliffore Clinton :13.3; Rod Clinton :07.5.

The speed was held at Rosecrans, with all classes combined and a handicap system on the "D's." The "A's" got 30 miles added to their speed. "B's" 20, "C's" 10, and the "D's" and jets just flew. The winners were: *U-Control Speed Open*—Lew Mahieu 158.46 (a "B" plus 20 miles); Charles Schuette 145.00 (a "B" plus 20 miles); L. W. Christensen 144.00 (Jet); Sr.—Richard Rigney 148.80 (a "B" plus 20 miles); Bill Wisniewski 126.32 (D); Jr.—Steve Jentges 133.31 (a "B" plus 20 miles); *U-Control Stunt Open*—Bob Palmer 417.5; Cliff Potts 392.5; Don Anderson 377.5; Sr.—Russ Snyder 377; Chuck Kim-brough 369.5; Carol Sliger 225.5; Jr.—Harold Selson 359; Barry Robertson 338; Dean Wint-ers 263.

The Free Flight events were run off Sunday, October 2, at Western and Rosecrans. Winners were: *Free Flight Gas Open*—Bob Hanford 25:33.6; Frank Newquist 20:42.5; Joe Foster 16:53.8; Sr.—Bob Brawner 22:20.7; Russ Snyder 13:48.4; Dale Garot 9:38; Jr.—John Bollinger 12:20.7; Bill Pitts 11:10.3; Frank Pollard 8:34.6; *Free Flight Rubber Open*—Don Donahue 22:36.8; Al Trainor 22:06.6; Del Harbold 19:44.4; Sr.—Bob Banner 16:10.3; Leon Arledge 15:14.4; Check Diller 14:31.7; Jr.—Robert Isaacson 9:21.3; R. Mahler 3:43.4; Howard Zalkin 2:58.6; *Novice*—Wade Allen 3:16.6.

Three new A.M.A. records were established at the Western Open. Bob Brawner with a total of 22:20.7 min. in the free flight

gas event, established a new Senior Class C record. In the speed events, a new mark of 138.41 in B Open was set, and on a record run, a time of 155.56 in D Open was set, both by the conductor of these columns.

An added attraction at the Western Open was the appearance of Northrop's YB-49, the eight-engined Jet wing. The flying wing was putting on a demonstration over Northrop Field, about a mile Northwest of Western and Rosecrans. The impressing thing about the B-49 was its high speed. The 172-foot wing spread ship appeared to have a speed greater than that of the accompanying F-80, which would drop way behind on shallow dives when buzzing the field.

We can still taste that delicious Bar-B-Que we had at the banquet of the Fourth Annual Western U-Control Contest held in Las Vegas, Nevada. The meet was sponsored by the Fred S. Pennington, Post No. 1753, Veterans of Foreign Wars, and conducted by the Nevada Aveyites. One thousand dollars in trophies were awarded, split among the top three winners in each event. Ralph Wilson was Contest Director with George Niebauer acting as his assistant. The Directors and Aveyites did an excellent job of running the two-day meet, October 15 and 16. Due to the large number of events, we shall list the first and second place winners only. The Team Racing was held October 15th at 7:30 P.M. Winners were: Five-Mile Race; Granger Williams; Bud Hartranft. Ten-Mile Race; (main event) Lawrence Williams; Jerry Gaston. Winners of the Speed events were: *Class D Expert*—1. Jim McElroy 150:27; 2. Lew Mahieu 142.85; *Open*—1. George McKay 149.00; 2. Bob Miller 139.53; Sr.—Gene Stiles 157.60; Charles Bauer 90.00; Jr.—Jim Reder 109.09; Steve Jentges 107.14; *Class C Expert*—Lew Mahieu 150.63; Jim McElroy 129.50; *Open*—George McKay 128.02; Joe Mueller 127.66; Sr.—Dick Rigney 125.87; Howard Brown 123.28; Jr.—Steve Jentges 109.09; *Class B Expert*—Charles Schuette 135.32; Lew Mahieu 126.76; *Open*—Herman Shiman 132.35; Jerry Strom 116.12; Sr.—Dick Rigney 133.33; Gene Stiles 130.43; Jr.—Dick Ferguson 115.38; Jack Siebenhaar 102.85; *Class A Expert*—Lew Mahieu 126.76; Bob Lauderdale 118.42; *Open*—Herman Shiman 120.00; George McKay 111.11; Sr.—Gene Stiles 118.42; Kevin Terry 100.00; Jr.—Steve Jentges 100.00. *Stunt Open*—Don Gulotta 415; Cliff Potts 377; Sr.—Russ Snyder 366; Doug Bell 340; Jr.—Harold Selson 372; John Selson 110; *Ladies Stunt*—Lee Galloway 56. *Team Stunt* winners were—Russ Snyder and Cliff Potts; Don Gulotta, Bob Palmer and Bill Lynn; *Scale Sr. and Open*—S. Estrada—Navion; A. W. Wright—Beechcraft; *Scale Jr.* Vaughn Brewer—Monocoupe. *Sweepstake Winner*—Lew Mahieu.

Some of us had a long drive to the Meet but not nearly as far as Gene Stiles, Herman Shiman, and Kevin Terry. Their jaunt was 600 miles from Alameda, Calif. There were also spectators and contestants from Salt Lake City, Utah, and Phoenix, Arizona. There were four AMA records broken at the meet, Class A Sr. record is now 118.42 by Gene Stiles; Class B Sr. 133.33 by Dick Rigney; Class A Open 126.76; and Class C Open 150.63 by Lew Mahieu.

From Northern California "Mom and Pop" Robbers send us the results of the Modesto U-Control Speed and Precision Meet held Sunday, October 9. *Class A Speed Expert*—Herman Shiman 120.80; Gene Stiles 119.20; *Advanced*—Erick E. Moline 104.04; Frank Hampton 101.58; *Beginner*—Jerry Pacheco 102.85; M. A. Severson 101.58; *Class B Speed Expert*—Herman Shiman 135.23; Mark Brown 127.66; *Advanced*—Dick Shelton 116.12; Kevin Terry 111.45; *Beginner*—Bob Goldstein 105.88; Jerry Pacheco 104.95; *Class C Speed Expert*—Erwin Huth 146.34; Gene Moni 121.62; *Beginner*—H. C. Albright 131.86; Bill Angwin 94.63; *Class D Speed Expert*—Erwin Huth 154.37; Gene Moni 145.74; *Advanced*—Guggemos and Spurgin 124.13; George Brown 97.56; Be-

(Turn to page 52)

# PLENTY OF PARTS

FOR



ON HAND AT  
ALL TIMES

Get genuine Super-Cyclone Engine parts from your local dealer. If he does not have them send us your order and your dealer's name and address.

**WRITE US NOW**

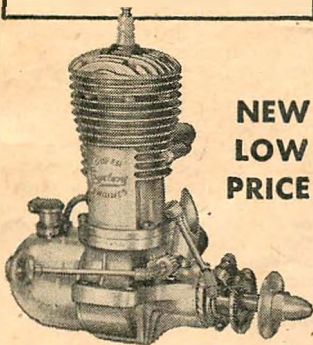

NEW  
LOW  
PRICE

NOW ONLY \$ **1295** AT YOUR DEALER

## DEALERS

Stock up now... with genuine Super-Cyclone parts and develop greater value in increased service volume.

**CONTACT  
YOUR LOCAL JOBBER**

**SUPER-CYCLONE, INC.**

GRAND CENTRAL AIR TERMINAL  
1310 AIRWAY  
GLENDALE 1, CALIFORNIA

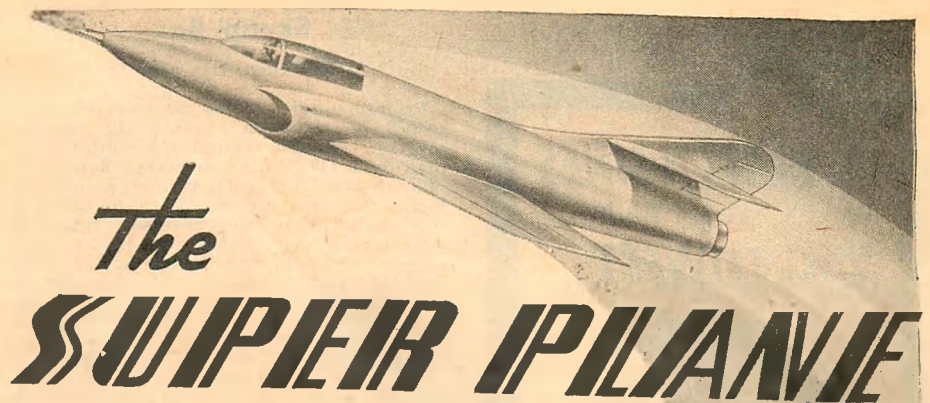

# The SUPER PLANE

OF TOMORROW WILL BE DESIGNED BY TODAY'S STUDENTS



— whether the problem is to design a large super-bomber or to design a small midget racing plane — whether it is to design the airplane body, its engine, or a small bracket within the airplane — All these design problems will be solved by men who have been trained in Aeronautical Engineering.

CAL-AERO TECHNICAL INSTITUTE SPECIALIZES IN

## AERONAUTICAL ENGINEERING

MAXIMUM TRAINING IN MINIMUM TIME

YOUR ONLY PREREQUISITE is the DESIRE to become an aeronautical engineer. All you have to do is seriously to want to be one—Cal-Aero will give you the kind of training that will enable you to do just that. For 21 years Cal-Aero has helped its students become trained and successful leaders. What it has done for its graduates, it can do for you. We have the experience—there is no substitute for it.

Some questions that must be on your mind:

- Exactly what is an Aeronautical Engineer?
- How can I get the education?
- What are my chances for employment after graduation?
- What are housing conditions?
- How long will it take me?
- What does it pay?

Cal-Aero also offers a successful course in **MASTER AVIATION MECHANICS** leading to airplane & engine license—CAA rating.

Cal-Aero Technical Institute has the highest technical approvals, both educational and industrial—with highest recognition by the Aircraft Industry for 21 years, for valuable service rendered.



Send coupon NOW for the answers to all your questions, or write us a letter. We will gladly assist you in any problems you may have.

APPROVED FOR  
VETERANS

BE WISE—PROTECT YOUR FUTURE  
TRAIN  
IN  
SUNNY  
SOUTHERN  
CALIFORNIA

**DON'T DELAY • MAIL TODAY**

CAL-AERO TECHNICAL INSTITUTE, Grand Central Air Terminal, Glendale 1, Calif. • Send full information and catalog, free and without obligation on courses checked below:

- CAREER COURSES
- AERONAUTICAL ENGINEERING
  - MASTER AVIATION MECHANICS
- HOME STUDY COURSES
- AERONAUTICAL DRAFTING
  - AIRCRAFT BLUEPRINT READING
  - STRESS ANALYSIS AND DESIGN

NAME \_\_\_\_\_ AGE \_\_\_\_\_

ADDRESS \_\_\_\_\_

CITY \_\_\_\_\_ ZONE \_\_\_\_\_ STATE \_\_\_\_\_

Check one:  Veteran  Non-Veteran

N-1



1. **the BEST ENGINES**  
ever built  
2. **at the LOWEST**  
**PRICE**  
at which good engines  
have ever been sold!

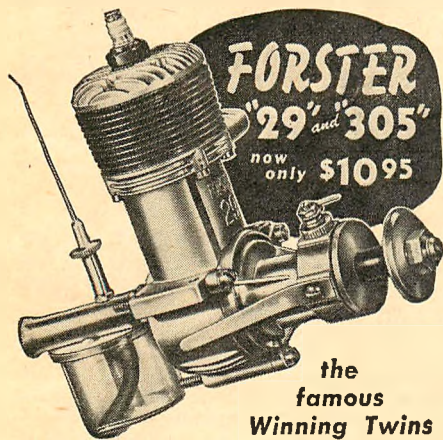

the famous  
**Winning Twins**

Consistent winners and record holders, featuring ball bearing crankshaft, modern design, high speed and high power output, glow plug or spark ignition, two-speed timer optional! FORSTER "29"—the cream of class B engines, FORSTER "305"—a class C companion! Switch engines to fly in both classes with some plane!

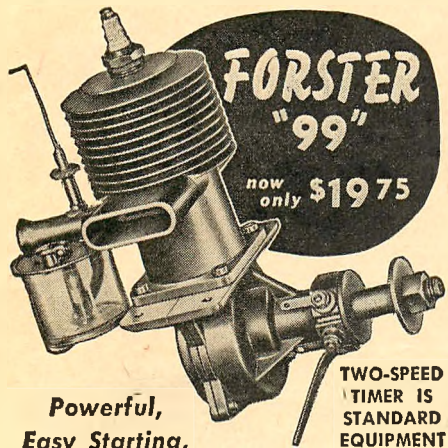

TWO-SPEED  
TIMER IS  
STANDARD  
EQUIPMENT!

**Powerful,  
Easy Starting,  
for Radio or U-Control, Stunt  
and Winning Precision Flying**  
**AT YOUR FAVORITE STORE**

See these outstanding FORSTER engines at your dealer. Note the unsurpassed workmanship, the quality evident in every detail! Buy and fly a "FORSTER" for easy starting, for dependable long service and the most fun and thrills you ever had.

Write for FREE Descriptive Literature

**FORSTER Brothers**  
P. O. BOX 375  
LANARK, ILLINOIS

## Scrap Box

(Continued from page 1)

Prototype flying of the gas-powered scale would be rated on starting (10 points), take-off (10 points), climb (10 points), normal flight (10 points), prototype flying (50 points), and landing (10 points). In normal flight, five laps are necessary to qualify; this qualification being necessary before a ship would be eligible for any of the awards. Considering all these factors, your best bet would be category D, under types, for "light, private, or executive type models." These are easiest to make, easiest to fly, and prototype performance is merely straight and level flying. The rule specifying a scale maximum of 1" will work against racing planes due to their original small spans, or at least will limit such ships to a very small size.

Rigidly defined events may be essential but at times this stylized flying can be a swift pain in the neck. With this agrees the Model Aircraft League of Saskatchewan, a veteran organization dating back to the early 30's in above-the-border flying. After regaining "unreformed" model types who had left for service during the war (free fighters to you fellows) the Canadian outfit was searching for ways and means to keep everybody happy at contest time. The solution certainly is novel. Here's T. H. Biggs, of Regina, to brief us.

"One of our biggest headaches was the lack of entries if we followed the formal pattern of available events," begins Biggs. "This prompted some deep research culminating in a couple of really good contests this past summer. Can't advocate these ideas for any large scale set-up but for the little clubs, it may work out as well as it did for us.

"In U-Control speed, for instance, a big kick came from flying pure competition and putting on a good show for spectators. In the normal break-down of events into Classes A, B, C, and D, we found, maybe, just three or four models turning up in each class, with by far the greatest number in D, with the resulting number of smash-ups occurring in that class, owing to the fact that the majority of boys couldn't handle the hot stuff. Now, despite lack of entries, every fellow seemed to have a B job. We decided the answer was a single big speed event with any power plant permitted. Some means had to be found then to find a common denominator so that the different sizes could compete on a fair basis."

The way the Canadians solved this one can be credited to an idea published in MODEL AIRPLANE NEWS some years ago. A 10 mph penalty was imposed on the hot D jobs, such as McCoy, Dooling, Hornet, Hassad, etc., with smaller "B-B" jobs, like the Arden .199, Ohlsson, McCoy 19, being excepted. Lines for the jobs of less than .24 displacement were 55' with 70' lines for all larger or more powerful airplanes. In the first trial it was found that the small engines held their own against the all-port-and-glow-plug monsters.

"Here's the way we look at it," says Biggs, warming to his sales spiel. "The average D job seems to be clocking about 130 or so. Take off 61 for the displacement and the 10-point penalty and you have a logged 59 mph. A Class C might reasonably expect to pick up 120 on the watches. Less 49 for displacement, and 10 for penalty, and you have 61 logged. A Class B McCoy could do 85 which, less 29, leaves 56. A Bantam might mark down 65, less 19 for 46. Even an Arden .099 would not be hopelessly out-classed if it clicked off 50 which, less 10, would give 40 for the records. Thus, 61, 59, 56, 46, and 40 are not too great a spread and it does a lot of good to see the boys matching up their Ohlsson 23's against the giggle-juice burners. For record purposes, we keep track of the actual speed and lines used."

In free flight, all models were lumped into two classes: over .24 cu. in. and under .24. This, reports Biggs, worked out fine with the closest contest being fought between a big Westerner with the mighty

Orwick 64 and a little Airfoiler with the good old Forster .29. In hand-launched glider, each contestant is allowed exactly nine throws. This eliminates the filling in of masses of attempts and the idea is claimed to have solved the headache of running what is one of the most popular events in those parts. When gas had a stranglehold, a few old-timers dragged out the hand-launch gliders for a novelty at a contest and since then every balsa butcher in the area enters stablefuls of these simple models. The old-timers now are sneaking in the Wakefield and Mulvihill types, hoping that interest in rubber will perk up accordingly. So far it looks like rubber will be as popular as the all-balsa toss-ems.

There's no end to the ideas from Regina-way. They even have an appearance event which any model may enter, free-flight, speed, or stunt. For starting the engine you get 10 points, another ten for take-off, 130 for speed (speed less displacement), duration (total time in seconds on a 20-second run, divided by 3), 60 points for stunts (10 for each consecutive loop or lap of inverted flight, etc.), and 70 for appearance (alignment, finish, detail, cowling, covering, original features and workmanship).

"It can be seen," states Biggs, "that a speed model could accumulate high points for speed but lose out on stunt and perhaps appearance. A stunt job might stack up the points flipping around on the end of the lines but score low on speed. Although he cannot gain points on speed or stunt, the free fighter may accumulate 190 points assigned to those items by taking his total flight time of one 20-second flight, in seconds, and divide by three, the result not to exceed 190. This may sound like a raw deal but remember that it is highly improbable for a speed job to get more than 100 points in speed and stunt. If the free-flight stayed up five minutes, or 300 secs., its points would work out to 100. To compare, a speed job would have to do 160 on a .60 engine." Thanks, T. H. Biggs.

When, in the October, 1949, "Scrap Box," we reported that the *Magic Valley Gas Bugs*, Twin Falls, Idaho, had set what they considered an endurance record, keeping aloft a model Ercoupe for 45 min. on a pint-sized fuel tank, we little realized the boys take this endurance angle so seriously. Eagle-eyed Stanley Ehlinger recalls that a McCoy 19-engined job by Radford Hull, using a pint can of *Power Mist* as a tank, had flown 461 laps. With a 1 1/4 pint tank the same ship did 587 laps in 1 hr. and 10 min.; this with the thermometer hovering little above the zero mark. For a suggested standard, why not try team racers flown for endurance but with a fuel load considerably smaller than pint-sized fuel containers, but more than the 1 oz. limit now in use. For that matter, any reasonable fuel limit will bring out some interesting efficiencies in design, operation, engine and prop selection.

Speak of the devil, here's still another endurance flight that shames both the *Magic Gas Bugs* and friend Hull with his measly ol' 1 1/4 pints of fuel. On August 16 and 17 last, Bernice Jaynes made two flights, one lasting for 1 hr. 33 min., and consisting of 900 laps, the other going for 1 hr. 37 1/2 min., with 910 laps. "I believe the second attempt," says Bernice, "needing you he-men, 'is at least a starting point for others wishing to try.'" While the *Magic Valley* men passed the handle back and forth, Bernice did it all by her lonesome, from take-off to landing. That is the only legit way to set such a record, says she. Now, men, we really are going to give you a bad time. How did you do it, Bernice?

"The ship is an original 56-inch span, *Spitfire-60* powered, carrying a 2-1/3 quart fuel tank. Fully loaded, the ship weighs about 8 lbs. It was flown on 70' lines, at an average speed of 46.6 mph, and the flight covered 75.8 miles. It was my original intention to use ignition with gas and oil as fuel; however, it was impossible to find a battery hook-up that was satisfactory and that would stand up for that length of time. It was necessary to switch to glow plug operation, and I feel that the high volume of fuel consumed during glow plug operation was responsible for my failure to set  
(Turn to page 34)

# "THE NEW KINGPIN"

by Scientific



**\$3.95**

INCLUDING RUBBER WHEELS

**ONLY SCIENTIFIC GIVES YOU ALL THIS**

*Completely Prefabricated*

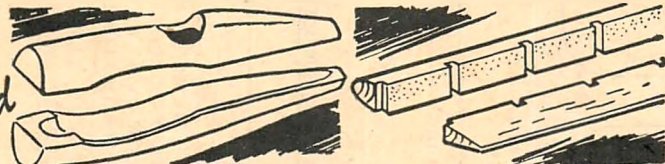

GENUINE CARVED Balsa FUSELAGE NOT BAND SAWN, MOLDED OR SHAPED

LEADING AND TRAILING EDGES SHAPED AND NOTCHED FOR RIBS



LANDING GEAR, READY FORMED SPRING STEEL

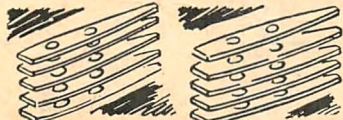

RIBS ACCURATELY DIE-CUT READY TO USE

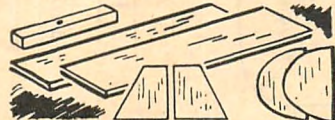

WOOD PARTS CUT AND DRILLED READY FOR FINISH SANDING

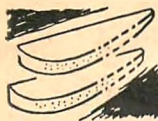

OUTLINE CUT Balsa WING TIPS



RUBBER WHEELS, HORN NUTS, BOLTS, ETC.



DIE-CUT BULKHEAD



DECALS, FORMED WIRE PUSH RODS



PLASTIC PILOT'S HEAD JUST PLACE IN COCKPIT

Only Scientific's modern up to date automatic machinery makes it possible to offer a sensational kit like the "KINGPIN" at the amazingly low price of \$3.95.

Compare the "KINGPIN" with others selling at \$4.95, \$5.95 and even \$7.50 and we dare say you'll find the "KINGPIN" the biggest bargain of all!

See your Scientific Dealer today!

Purchase the "KINGPIN"—Build it, Fly it, Stunt it,—put it through every possible test and if it doesn't Out Fly—Out Stunt—Out Perform every known model on the market we'll refund every cent you paid for it. The "KINGPIN" is fully guaranteed to give complete satisfaction.

## SPECIFICATIONS

Large wing area containing over 200 square inches with 8" chord and length of 28".

For all "A & B" engines of .099 to .29 displacement and some small class C engines. The "KINGPIN" may be flown Glo-Plug, Diesel or Ignition.

**SCIENTIFIC**  
MODEL AIRPLANE CO.  
218-220 N11 Market St.  
NEWARK, NEW JERSEY

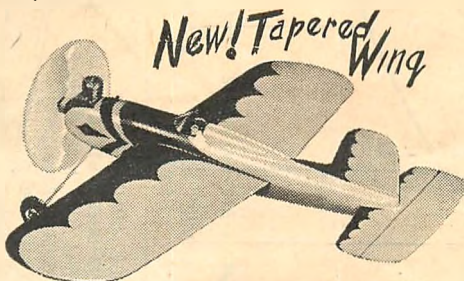

BUY FROM YOUR DEALER AND  
SAVE 15 CENTS MAILING CHARGE

**AMERICA'S FINEST  
100% Balsa KITS  
ONLY 35c EACH**

**NO DIE-CUT PARTS  
NO PLASTIC PARTS  
NO HARDWOOD PARTS  
NO CARDBOARD PARTS  
NO EXCESS WEIGHT  
GUARANTEED TO FLY**

THESE SCIENTIFIC SUPER - FLYERS ARE HONEST TO GOODNESS MODEL AIRPLANES, DESIGNED BY EXPERT FLYERS FOR LONG ENDURANCE FLIGHTS.



"WINDSOR" 35c  
25" Wing, rubber or small CO<sub>2</sub>



"BANTAM" 35c  
25" Wing, rubber or small CO<sub>2</sub>



"MAJOR" 35c  
25" Wing, rubber or small CO<sub>2</sub>



"ROYAL" 35c  
25" Wing, rubber or small CO<sub>2</sub>

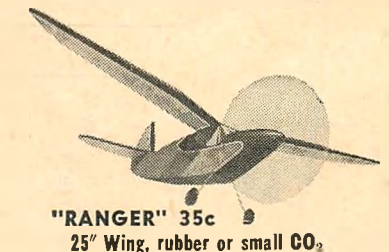

"RANGER" 35c  
25" Wing, rubber or small CO<sub>2</sub>

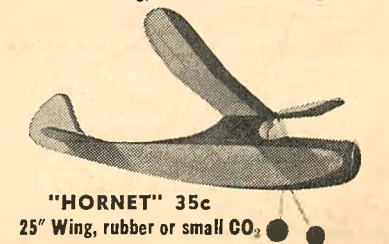

"HORNET" 35c  
25" Wing, rubber or small CO<sub>2</sub>

**ASK YOUR DEALER FOR THESE  
SCIENTIFIC SUPER-FLYERS**

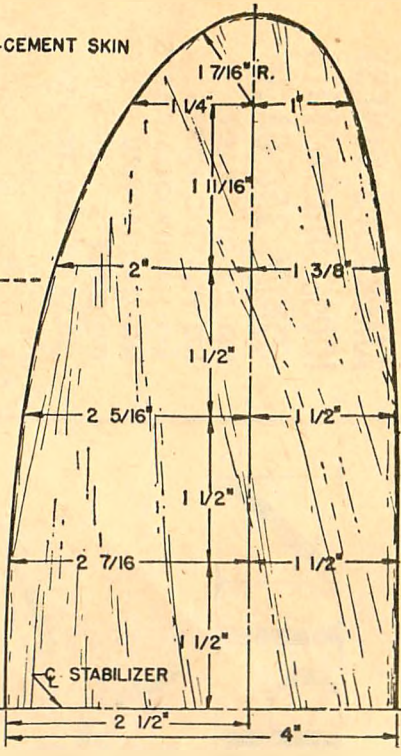
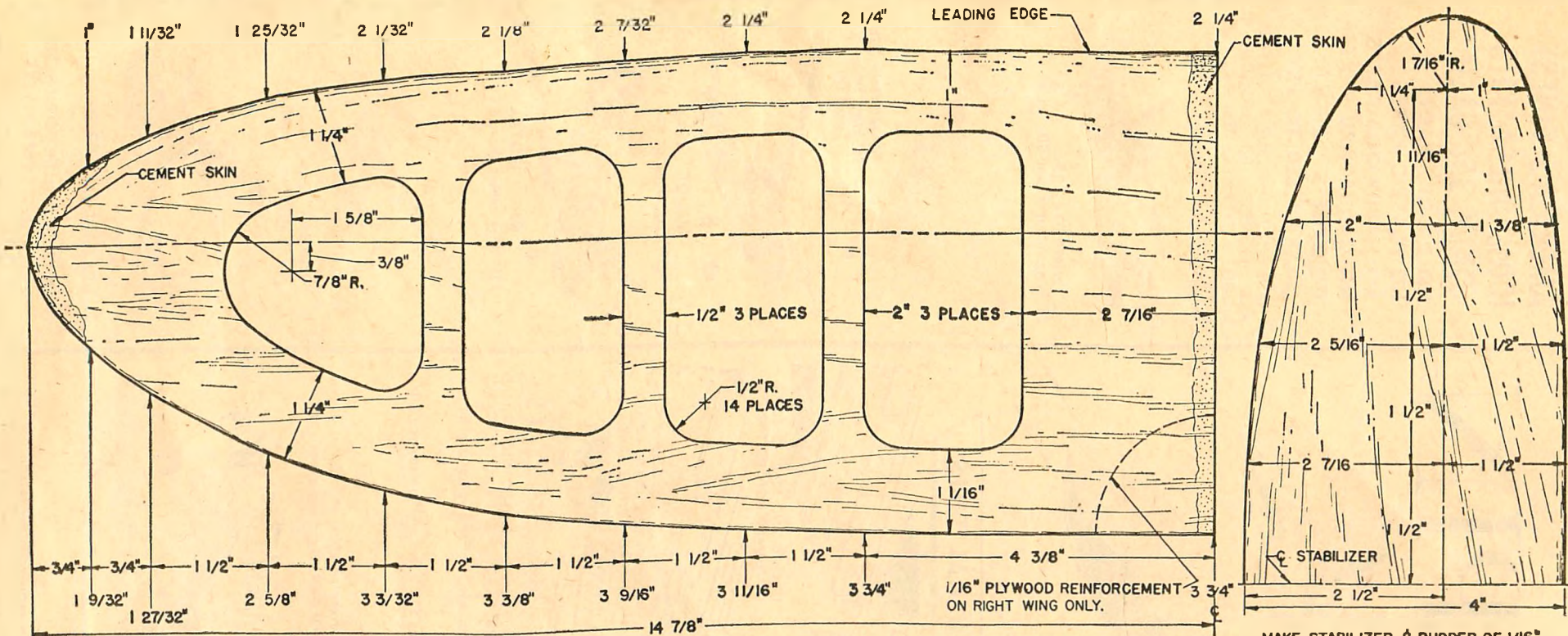

MAKE STABILIZER & RUDDER OF 1/16".

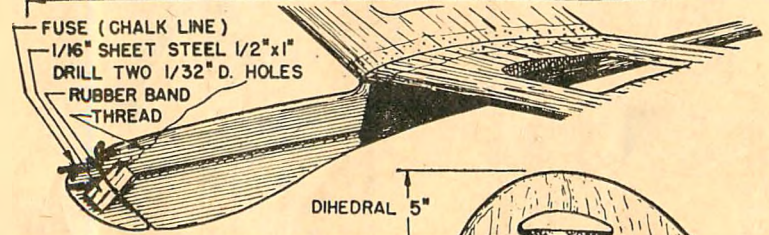

WING & TAIL SURFACES HALF SCALE

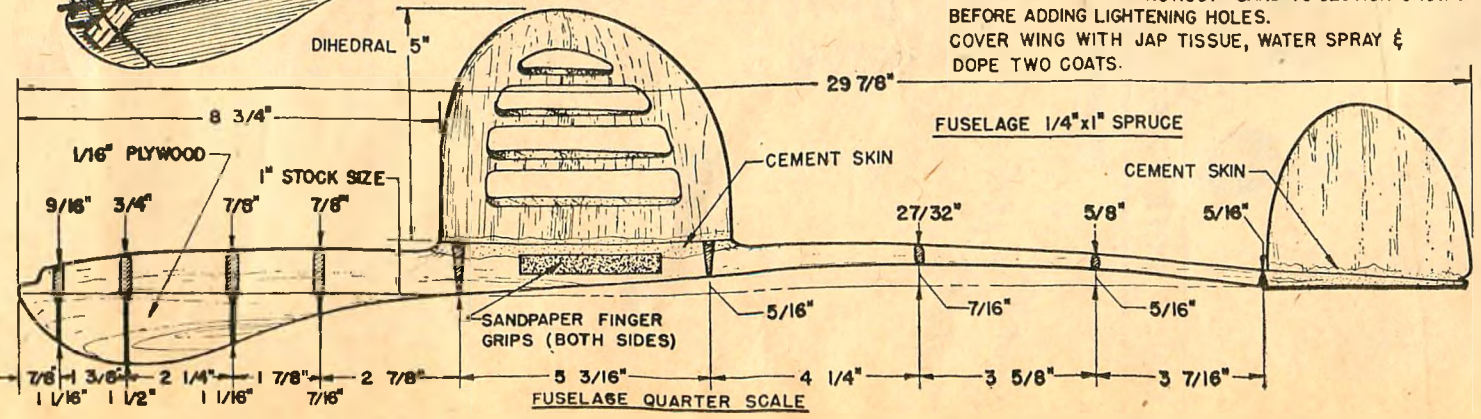
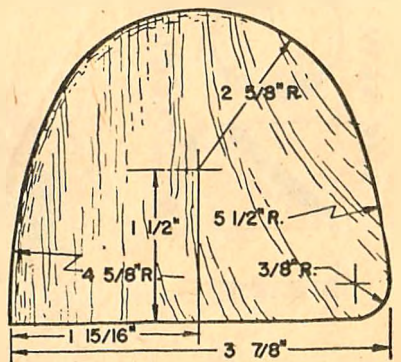
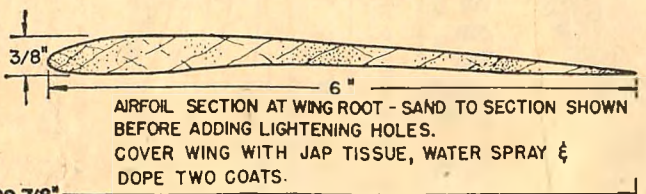

FUSELAGE 1/4"x1" SPRUCE

"THE MONSTER"  
 HOLDER OF ALL A.M.A. CLASS "D"  
 HAND LAUNCHED RECORDS  
 JUNIOR, SENIOR & OPEN  
 DESIGNED BY - RAY O. ACORD  
 DRAWN BY - BILL M. LANE



The Olathe win with a *Monster* boosted Ray to 1950 Nats Champ — many other Coast fliers have had great success with copies of this outstanding Class D design, including the *Flightmasters*, Club Champs

# the monster

by RAY ACORD

ABOUT two years ago I became very conscious of the fact that hand-launch gliders had progressed to a stage of perfection that made competition really tough. For the average model builder with an average throwing arm like myself, to try and compete with glider experts such as those found in the Oakland *Cloudusters*, including Degan, Slobad, and Bob Hanford of the Los Angeles area—well, we just didn't have a chance. Therefore, I decided if I wanted to fly against these fellows, I would have to try some altogether different approach.

The only thing I could see that wasn't near perfect with their models, was that they would fly out of sight too quickly, and sometimes spin in while in a violent thermal. My problem therefore, was to design a glider that would float well, and turn in consistent good times, considering my disadvantage of not being able to throw as well. Also the glider must stay in sight longer if it should catch a thermal. Last, but not least, the glider should not fly out of sight, therefore it must have a dethermalizer.

In order to make a glider that would conform to these requirements, it became obvious that it would have to be a large one. I then decided to check the AMA Records for Class D Hand-Launch, and that made up my mind for me. There was obviously room for experimental work and improvement in this Class. The finished result is a glider with a high undercambered wing, more than average dihedral, simple weight position change for dethermalizer action, plus a large keel on the nose to assist stability and help prevent spins.

The results are better than hoped for. Despite the size of the *Monster*, it can easily be thrown high enough to catch thermals. In fact, due to the size and light wing loading, together with a good airfoil section, it will pick up small risers that smaller gliders won't even respond to. This was amply demonstrated at the 1949 Nationals when at four different times, the *Monsters* flown by members of the *Flightmasters* Team turned in 3- to 4-min. flights, never getting up over 60' high, and usually landing within 200' of the launching point.

The best example as to the simplicity and ease of flying the *Monster*, is shown in the present Senior record held by Bill Wisniewski. Bill built a *Monster* which was his first hand-launch glider. Nevertheless, he established a new Senior record with his glider, the second time out. Jack Butler, Jr., set a new Junior record with a *Monster* the first time out with it. I have set a record, and twice raised it myself for Class D Hand-Launch with the same design. Others who have built and flown them, are sincerely pleased with their recovery and glide. Not only do they fly well, but I have had my glider in many thermals, and due to the dethermalizer have not yet lost it. That's about all if you haven't had your interest aroused yet, and want to build a *Monster*, I give up!

## CONSTRUCTION

**WING.** Select 2 pieces of medium lightweight balsa 3/8" x 6" x 15". Cut wing halves to the proper outline, then carve and sand in the undercamber. Care should be taken to make both wings exactly the same. Use undercamber throughout the entire span of the wing, clear out to and including the tips.

After both wing halves are shaped and sanded, make the cut out on each panel and remove.

**FUSELAGE.** Use a piece of stock 1" x 1/4" x 29 1/2". If available, use spruce. If spruce is not available, you may substitute bass or some other hard wood. We have had very poor results with balsa bodies. Cut and sandpaper your fuselage to shape. Refer to cross section shown on plans.

The method used in attaching the wing and stab to fuselage assures you of an 0°—0° setting.

The keel is made from a piece of 1/16" plywood glued into a long notch on the bottom of the fuselage. Do not glue keel into place until glider is all assembled.

**STAB AND RUDDER.** Use a piece of stock 1/16" x 4" x 14 1/2" and sand to shape as illustrated. We do not use a symmetrical section. The bottom of the stab is flat, with all camber and shape sanded into the top. The rudder is sanded to a symmetrical section.

Use a couple coats of sealer on the tail surfaces, and sand between each coat with very fine sandpaper.

**ASSEMBLY.** Here's another place the unique fuselage shape is good. Merely glue the stab into place. When dry, lay flat on a table top and cement the wing into position. Put some 5-3/4" blocks under each wing tip, and allow the joints to dry. The rudder may also be glued into place at this time.

Install the nose keel and also the reinforcement at trailing edge of wing which serves as a finger rest while launching.

When dry, add more cement to wing joints. After all these glued joints are dry, go back over the whole job and re-glue. Spread glue at all wing joints to form a skin at least 1/2" wide.

**FINISHING.** Apply one coat of sealer to wing, and sand with fine sandpaper. Cover wing *only*, with tissue. Apply two or three coats of thin dope.

**FLYING.** Adjust model for left glide circle of approximately 75' and no larger. Due to its size, you will find this model will safely handle a lot of rudder adjustment.

**DETHERMALIZER.** The dethermalizer was put on this glider because the model needs it. Don't fly without it, if there is the slightest chance of thermals being present, because you'll lose your glider.

A very good dethermalizer wick is the line used for wrapping fishing pole handles, or you can use chalk line. The

(Turn to page 53)



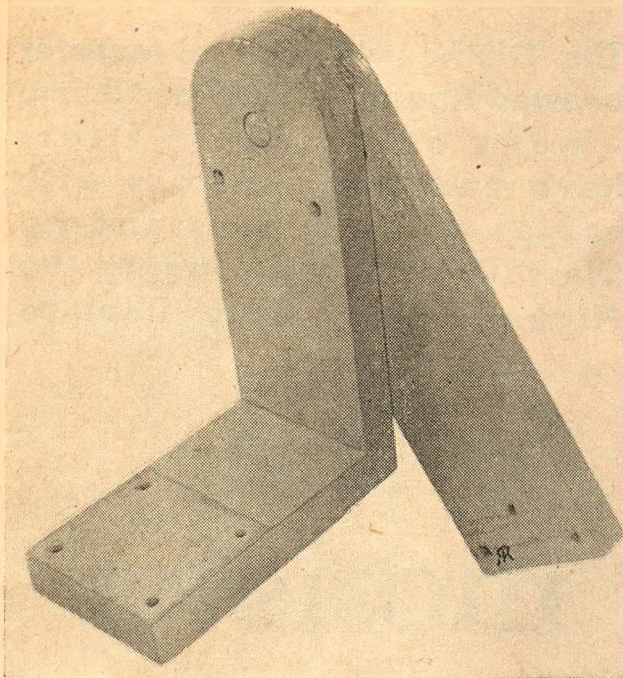

Upright, and L-shaped camera mount support

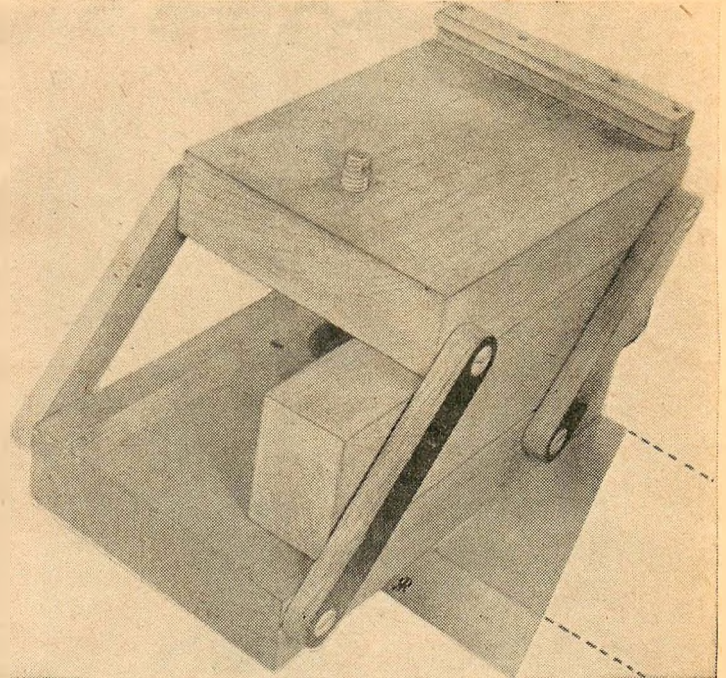

Linkage in "shooting" position with filler block in place

### PART THREE

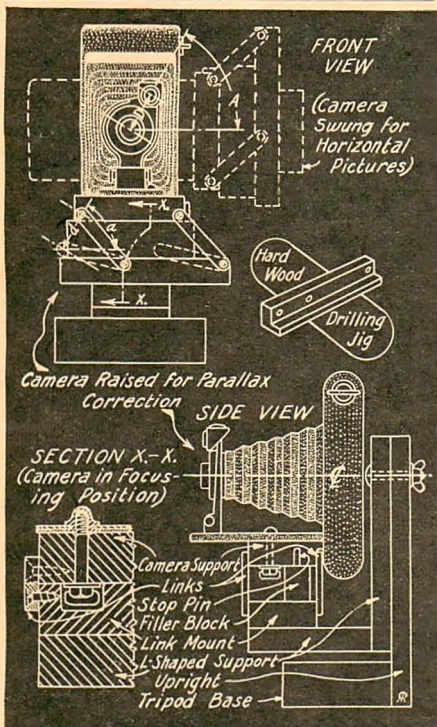

(Above) Parallax correcting mount  
(Below) Attaching auxiliary lenses to camera

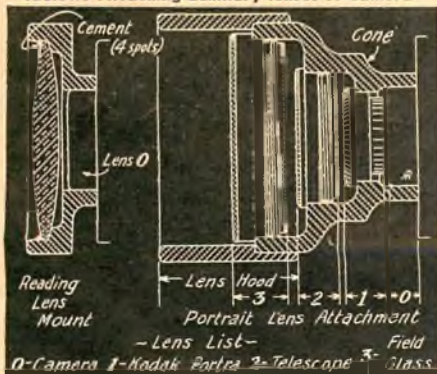

# model portraiture

by RAY RUSHER

**PORTRAIT LENS ATTACHMENT**—The usual setup is a series of three lenses having ratings of 3, 2, and 1 diopters. This provides for a full range of close-ups in which the distance from subject to lens is from 40" down to about 5½", if the last notch on the focusing scale is 3'. Between 10" and 5½" the lenses have to be combined, a 3 diopter lens and a 1 diopter lens having the same effect as a 4 diopter lens, 3 and 2 the same as a 5 diopter and 3, 2, and 1 the same as a 6 diopter.

Diopter can be translated into focal length by dividing 1 meter (39.3") by the number of diopters. This results in approximately the following equivalents:

Diopters	.....6	5	4	3	2	1
Focal Length (in.)	..6.5	7.9	9.8	13.1	19.7	39.3

A setup of three portrait lenses would cost about 8 or 9 dollars. Many war surplus lenses are now on the market\* costing from 10c to 30c each and will serve your purpose just as well. Meniscus, plano-convex or double convex lenses are suitable. By getting three lenses of about 13", 20", and 40" focal length and providing a supporting cone for them you are ready for portraits of models and even full size pictures of small gadgets about the size of the film you use.

While ordinary lenses are not corrected for color and introduce slight distortion of straight lines, especially in the shorter focal lengths and when combining lenses, by using a small stop, only the central portions of the lenses are used so the distortion isn't particularly objectionable.

\* Try Edmund Salvage Company, Post Office Box 100, Audubon, N. J., or American Lens Company, 5694-6 Northwest Highway, Chicago 30, Ill.

This also permits using chipped edge lenses which are readily procurable at small cost.

If you have a telescope or field glass, the front lens can be used as a supplemental lens for close-ups. They are usually achromats and thus don't introduce distortion due to color. The author has a telescope lens of 1-1/16" diameter having a focal length of 10-3/4", and a field glass lens of 1-3/4" diameter having a focal length of 8-3/4", in addition to a portrait attachment having a focal length of 52". These have worked out quite well for model portraits except for leaving a gap between 10-1/2" and 21-3/4" that can be pretty well filled by a 20" lens.

You may also have some miscellaneous lenses of unknown focal length that can be used. Old spectacle lenses and reading glasses are suitable. To check the focal length of a lens use it like a burning glass by focusing on a flat surface that will not catch fire. The distance from the surface to the center of the lens when the image of the sun on the surface is smallest and brightest is the focal length of the lens.

In general, when a supplemental lens is mounted in front of the camera lens with only about 1/16" air space between the two, the distance from the subject to the supplemental lens is the same as the focal length of the lens, when the camera is focused at infinity or the highest footage mark of the focusing scale. At that relationship the image is focused most sharply on the ground glass. Moving the lenses farther from the ground glass decreases the subject-to-lens distance so that greater enlargement is possible. The decrease of distance possible varies from about 45% for a 1 diopter lens to about 10% for a 6 diopter lens combination.

(Turn to page 48)

# Radio Control For All

R. C. enthusiasts have long wanted a "License-Free" band; it's now here and so is the equipment!

by VERNON C. MACNABB

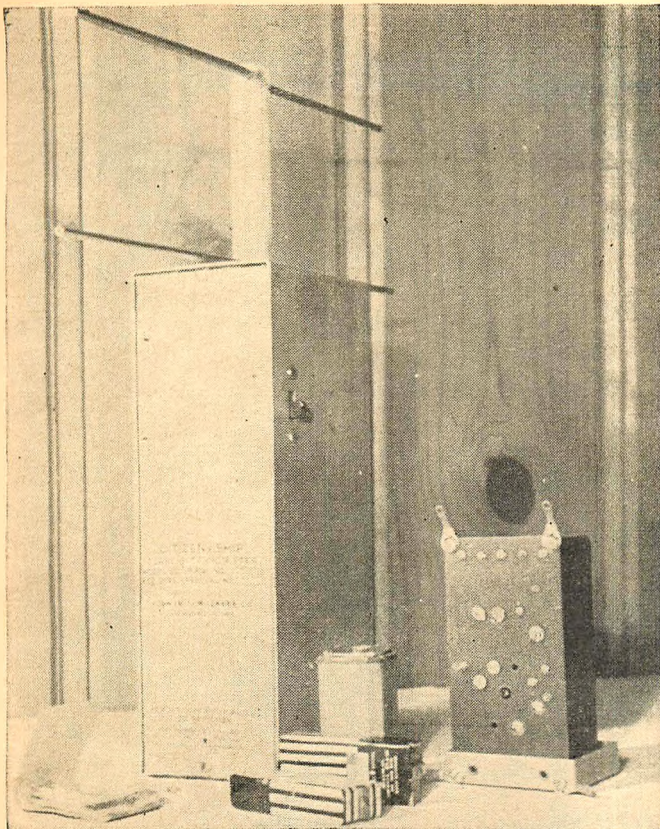

Transmitter is completely self-contained. Receiver with batteries at right

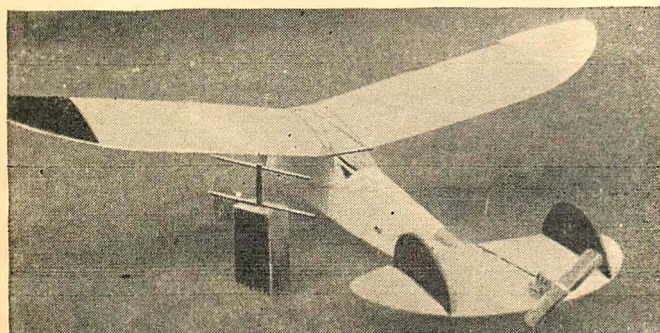

Test plane was controlled over the 465 mc. channel

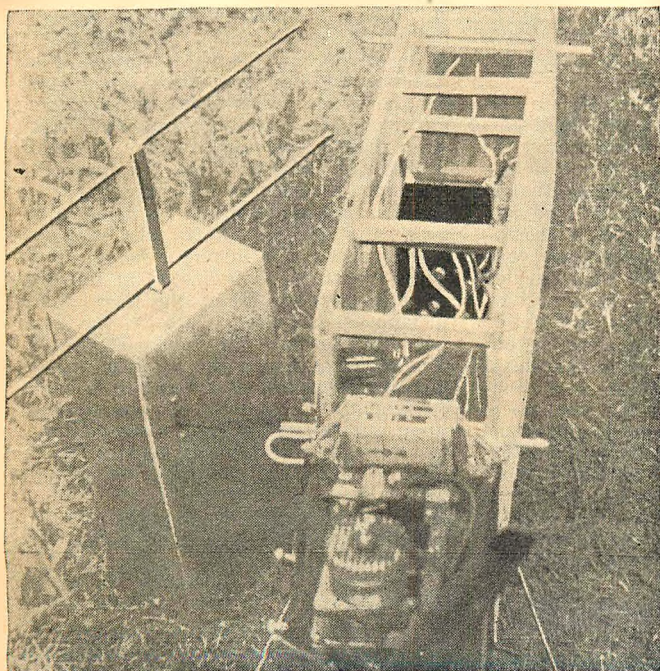

Receiver has built-in antenna, will fit in small cabins such as this

FOR well over a quarter of a century, it has been illegal by Federal edict to operate a radio transmitter without a license granted by a Federal Bureau, currently the FCC, or Federal Communications Commission. This law was modified in June, 1949, to allow the layman, Mr. John Q. Public, to obtain a license to operate a radio transmitter without the necessity of being examined to determine his technical knowledge of radio, or even of knowing one character of the International Morse Code. The Citizens Band, for plain citizens and model airplane builders and fliers, was opened June first. There are, of course, certain definite restrictions, because these transmissions must not interfere with already established and licensed services. They are excerpted as follows from FCC Rules and Regulations governing the Citizens Radio Band.

1. Any citizen of the United States eighteen years of age or older is eligible for a station license.
2. No more than one person may be licensed for the same apparatus.
3. Any person may operate a station with permission of the licensee. The licensee must be responsible for the station operation at all times.
4. Application for a station license using FCC approved equipment must be made on FCC Form 505. This is available from any FCC Field Engineering Office or from the Federal Communications Commission, Washington 25, D. C. Approved equipment will carry a name plate showing the FCC type approval number.
5. When using non-approved equipment, a construction permit application must be filed on FCC Form 505. After completion of construction, the station license application is made on FCC Form 403.
6. Licenses are issued for five years and may be renewed at the end of that time.
7. The serial number on the license will constitute the station call signal. Stations licensed for radio control are not required to broadcast their call signals.
8. The address of the licensee will be the official license location of the station, although the station may be operated anywhere within the United States.
9. Stations used for radio control must not radiate energy continuously.
10. 

Frequencies	Class of Station	Maximum Power
460-462 mc.	"A" (at fixed locations only)	50 watts
462-468 mc.	"A" and "B"	10 watts
468-470 mc.	"A"	50 watts
11. Frequency Tolerance:  
 Class "A"  $\pm 0.02\%$  of frequency to which transmitter is adjusted.  
 Class "B" All operation shall be confined to 465 mc.  $\pm 0.4\%$ .

Item 1 above may look at first reading like a definite limitation to our junior model builders, but item three (3) takes junior off the hook. His dad (and whose dad would not) may obtain the license and junior may use it.

Item 4. A list of Field Engineering Offices with their telephone numbers is as follows:

- District No. 1—Customhouse, Boston, Mass., Hubbard 2-6200.
- District No. 2—Federal Building, New York, N. Y., Watkins 4-1000.
- District No. 3—U. S. Customhouse, Philadelphia, Pa., Market 7-6000.

(Turn to page 36)

# design forum

by CHARLES H. GRANT

DESIGNING model airplanes has been reduced to a science by the majority of model fans in all respects except one and that is the propeller. When model builders come to the problem of putting the right propeller on the right airplane, fancy and not reason often dictates the solution. Apparently this problem involves so many vital and changing factors that it defies solution by the average builder; even aeronautical engineers do not always know what propeller to put on a particular model plane. To work out the answer precisely, requires long complicated mathematical processes and most fans are either not interested in working out these processes or are incapable of doing so. Consequently, an easy approximate method of determining the precise and correct design of propeller to use on any model is greatly needed.

On the other hand, some do not even suspect the importance of selecting the right propeller for a particular model. No doubt you have attended contests where models of mediocre design have placed among the winners. This has occurred so often many fans conclude that the design of a model is unimportant. They have attributed excellent results with models of poor design to thermals, or just plain luck. This may be true in some cases but the one factor most often responsible for such unexpected and apparently haphazard results is the propeller. Perhaps we should not say just the propeller, because in itself a propeller may be of excellent design yet give very poor results on a particular airplane. It is more accurate to say that poor flights result from the *wrong combination of propeller and airplane*. The propeller and the model are very much like a team of horses, for maximum efficiency they must pull together and cooperate in their efforts. The secret of having the propeller and airplane properly coordinated lies in having the correct relationship between the pitch speed of the propeller and the flying speed of the airplane. Let us examine the action of a propeller to determine why this is true.

A propeller blade is in effect an airfoil or wing, which is passing through the air in a horizontal spiral path. These blades "lift" just as a wing lifts but in their case the lift on the section is called *thrust* because the resultant force acts horizontally to pull the propeller parallel to its axis. Just as on an airplane wing this thrust or "lift" on the propeller blades varies with the speed of the blade and with the angle-of-attack. It is obvious that greater speed gives greater thrust and that greater rotational speed is obtained when the drag on the blades is minimum. So the problem resolves itself into establishing a situation where the propeller blades DURING FLIGHT pass through the air at an angle of attack which produces the greatest amount of thrust with the least amount of drag. This angle, as in the case of the wing, is the angle of the

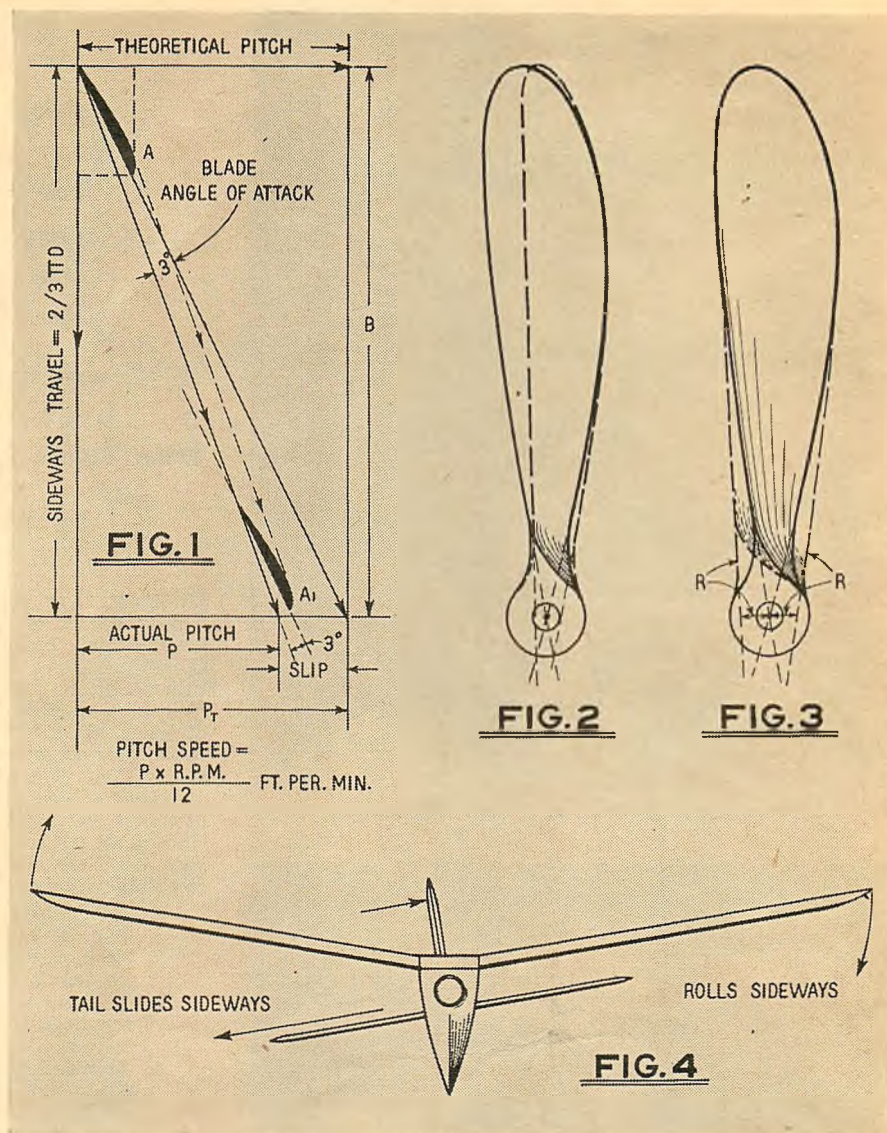

maximum lift-drag ratio. Though this angle varies with different airfoil sections, the average prop section gives maximum efficiency at approximately  $3^\circ$  angle-of-attack. The mystery has been to determine what pitch, diameter, and blade area should be used on a propeller for each particular airplane.

Usually every airplane requires a different propeller for maximum flight efficiency. The common conception that the efficiency of a propeller may be determined by measuring the thrust that it develops while mounted in a fixed and stationary position is completely worthless as far as accurate results are concerned, because a propeller may develop a large thrust while in a fixed position but comparatively little thrust in flight on a particular airplane. This depends entirely on whether the blades operate at the angle of maximum efficiency,  $3^\circ$  during flight. If the drag of the airplane in flight is excessive compared to the thrust of the propeller, the blades may be acting at  $6^\circ$ ,  $7^\circ$ , or  $8^\circ$ , in which case the drag on the blades is high compared to the thrust delivered because the lift-drag ratio is low at these angles. In such a case the high drag reduces rotational speed and thereby the thrust.

The first step in determining the correct propeller to use on a particular model, is to determine the *pitch speed for maximum efficiency*. Look at Fig. 1. This shows a cross section of a propeller blade

A, as it passes through the air during flight. It moves forward a distance  $P$  in every revolution and due to its rotation it moves sideways a distance  $B$  in every revolution, to position  $A_i$ . The forward motion  $P$ , is the actual pitch, while  $P_t$  is the theoretical pitch.  $B$  represents the distance traveled in a circle by a point on the blade two-thirds of the radius out from the hub. So the actual sideways distance traveled on one revolution is  $2/3 \pi D$ , where  $D$  is the propeller diameter. In order to have this propeller develop maximum thrust with minimum drag and engine effort, the propeller blades must pass through the air at  $3^\circ$  angle-of-attack as indicated in the diagram. So instead of moving forward the distance  $P$  in every revolution, the blade will move forward the shorter distance  $P$ . The speed at which the propeller moves forward along the flight path while operating at its most efficient angle, depends upon this actual pitch and its revolutions per minute. The product of the actual pitch  $P$ , and the number of revolutions per minute is called the *PITCH SPEED*. Obviously, this is dependent upon the speed at which the engine turns the propeller.

To have over-all efficiency the engine must operate at its most efficient speed. In the case of most modern engines this is approximately 10,000 revolutions per minute but this varies with different (Turn to page 44)

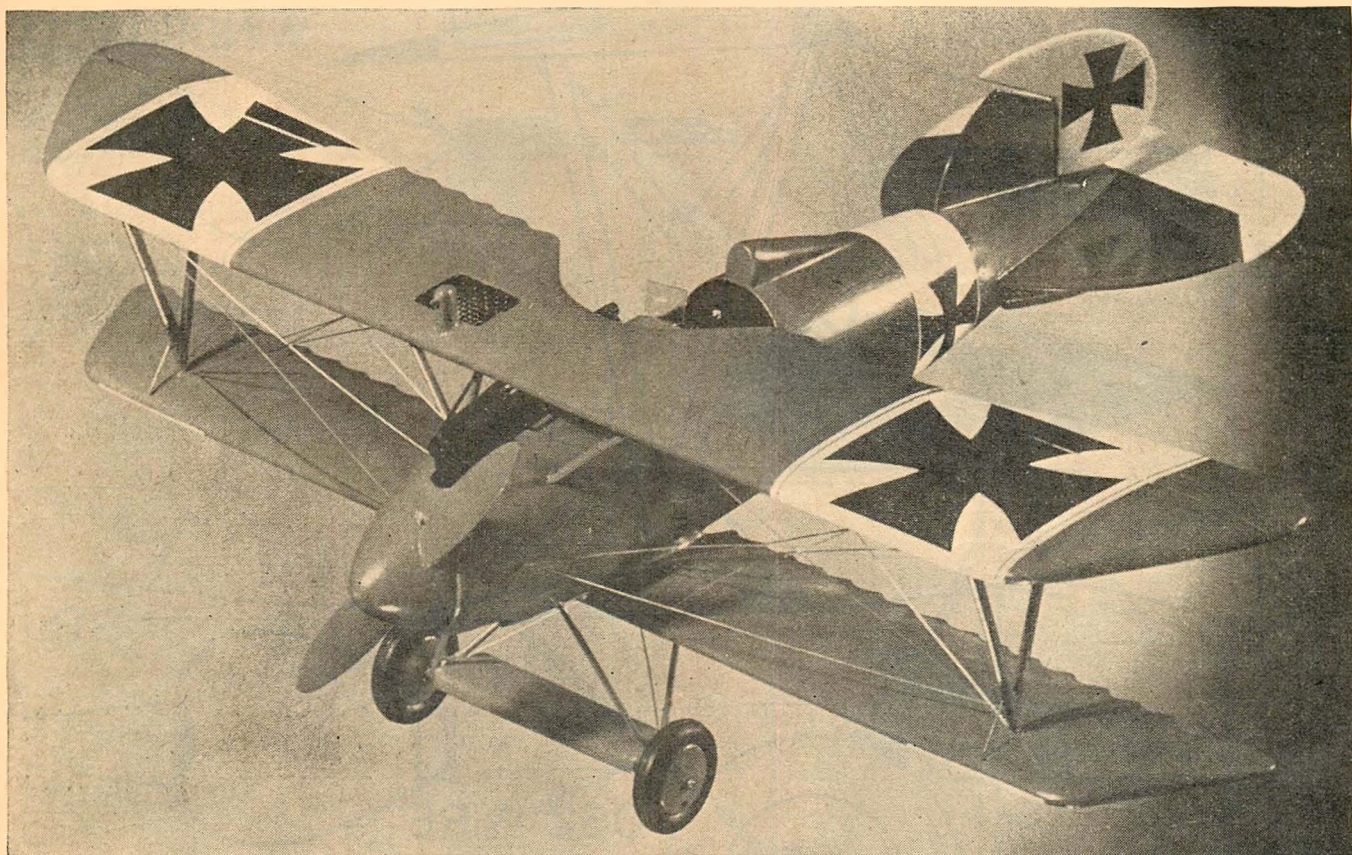

# albatros pole-liner

by FRANK EHLING

**Read here how to build and safely fly your own copy of the plane on this month's cover**

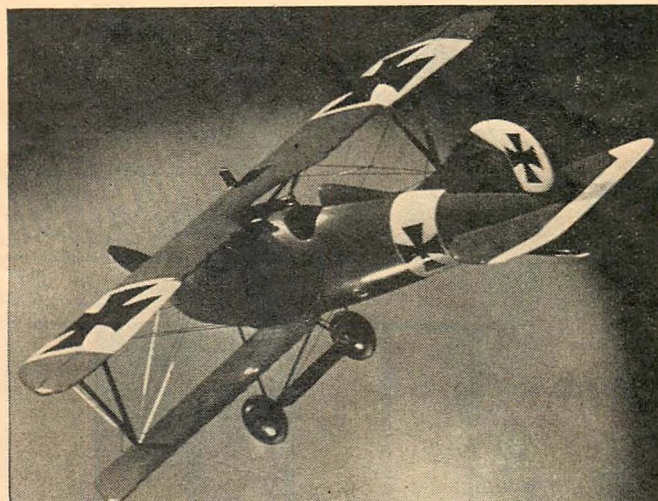

**S**CALE models have for some reason captured the heart of the model builders, and World War I models seem to hold the edge when it comes to building, for here the builder can really let himself go and turn out a realistic and colorful job.

The construction of our Albatros can be simple—there is no need to build up the fuselage as this would be a big task in itself. Just hollow out the fuselage enough to take the engine and tank. The wings are built up with no central spars, and the ribs are trimmed to shape after they are cemented in place.

The model can be flown U-Control, or on one line in the club room. Pole-line flying is probably the safest of all and is described later. The Albatros has great eye appeal, and the shine on your model will put a gleam in the judge's eye! The model builder can't use the excuse that he hasn't the required tools, for with a coping saw, razor blade, sandpaper, and a 3/8" sable brush, you can produce a fine model.

The original model, pictured here was built to carry an English *K Hawk* diesel engine which has a displacement of .012 cu. in. and weighs about 1 oz. The tiny American glow plug engines were not available then. When they came out, the plane was modified so that an Anderson *Spitfire* could be used, but any of the tiny diesel or glow engines can be fitted, or you could use an O. K. CO<sub>2</sub> power plant.

To start out, the fuselage can be carved first, and it is made from a soft balsa block. Shape the fuselage to cross section and

then hollow out to fit the engine; install a plywood firewall. Be sure that the area around the exhaust ports is open, as this will prevent fire.

Cut out the area for the landing gear to be installed a little larger than necessary, so each leg of the gear can be installed in a bead of plastic wood, as this is a fine way to hold it to the balsa fuselage. The spreader bar can be cut from balsa and cemented in place and be sure that it is *well* cemented. The cockpit is now cut out and fitted with any details that are desired.

If the builder wants a finished job, the dummy engine is a *must*. There are many ways to make this; however, the original was easy and all that is required is to mould the exhaust pipe out of plastic wood, carve the cylinders out of balsa (they can be capped with dress snaps for added realism) and the rest of the detail is made up with bent pins. Cement the engine parts together and paint black. Carve a slot in the fuselage to accept the scale engine, and after the fuselage is painted, the engine can then be slipped into place.

The wheels can be made true to scale if the sides are capped with balsa cones to form a cross section as shown on the plans. The guns can be made up with dowels or tubing. The tail assembly is cut out of 1/16" sheet balsa. It is not necessary to form a streamline shape, just be certain the edges are sanded

(Turn to page 50)

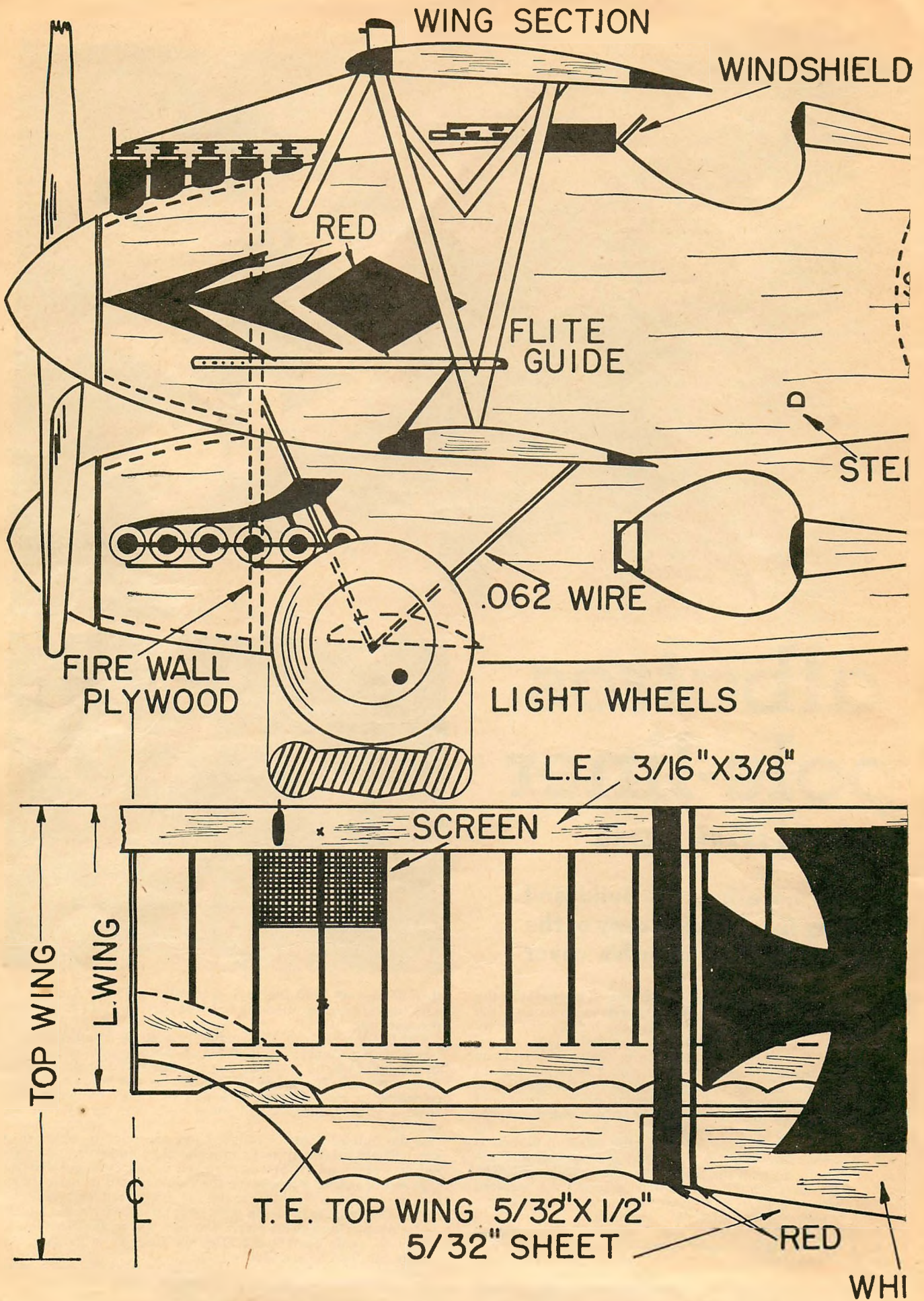

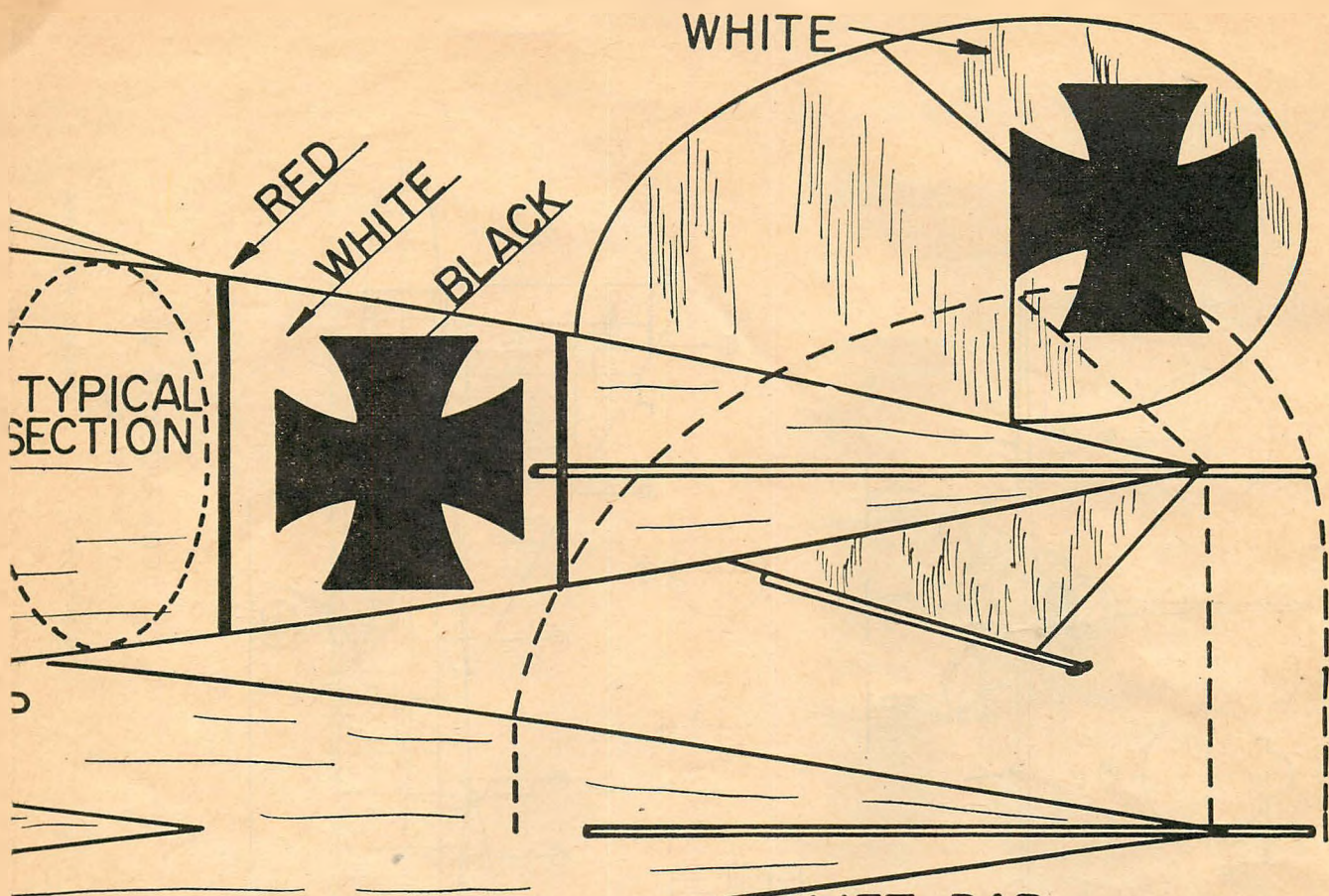

LIFT BAR

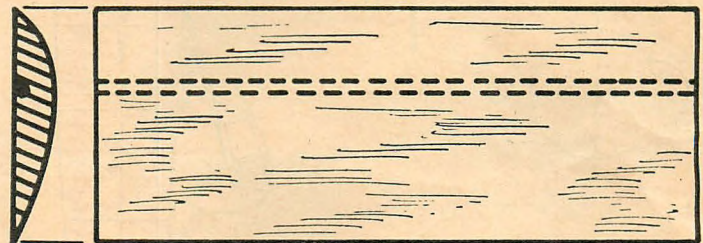

RIBS 1/16" SHEET

TIP 3/8" SHEET

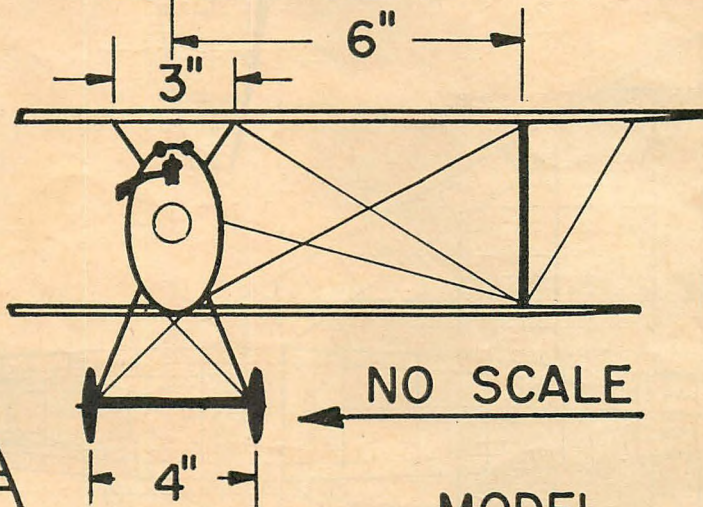
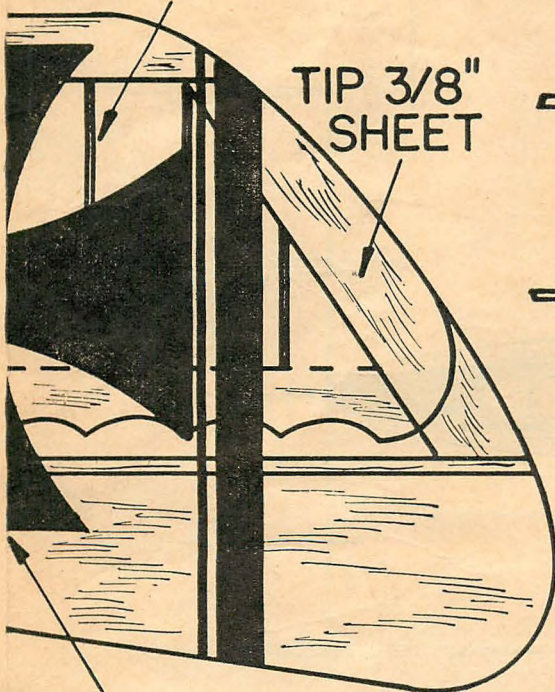

NO SCALE

MODEL  
LIGHT BLUE

TE  
BLACK

ALBATROS  
SPITFIRE POWERED  
SCALE - FULL SIZE

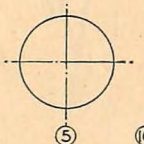
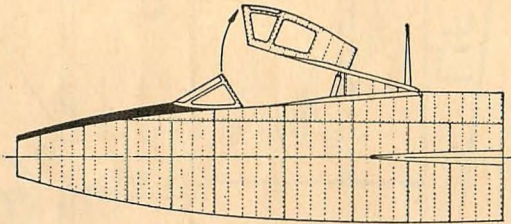
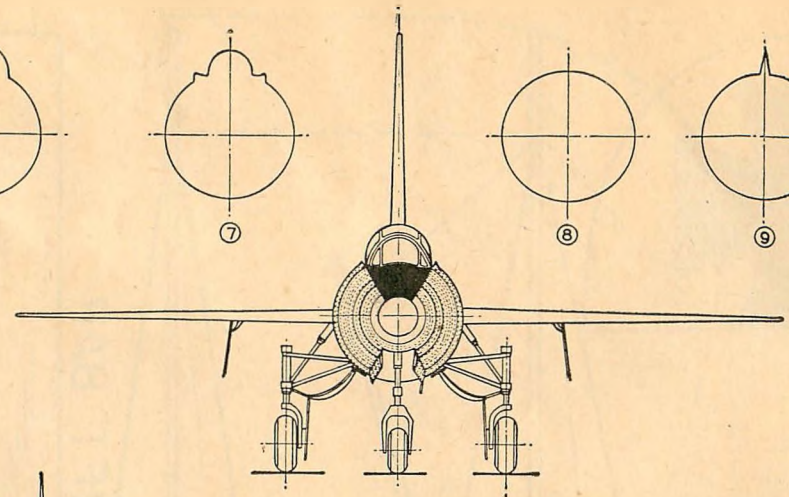
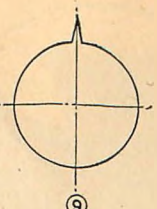
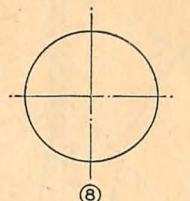
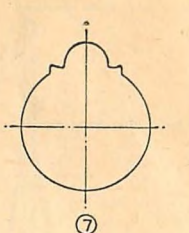
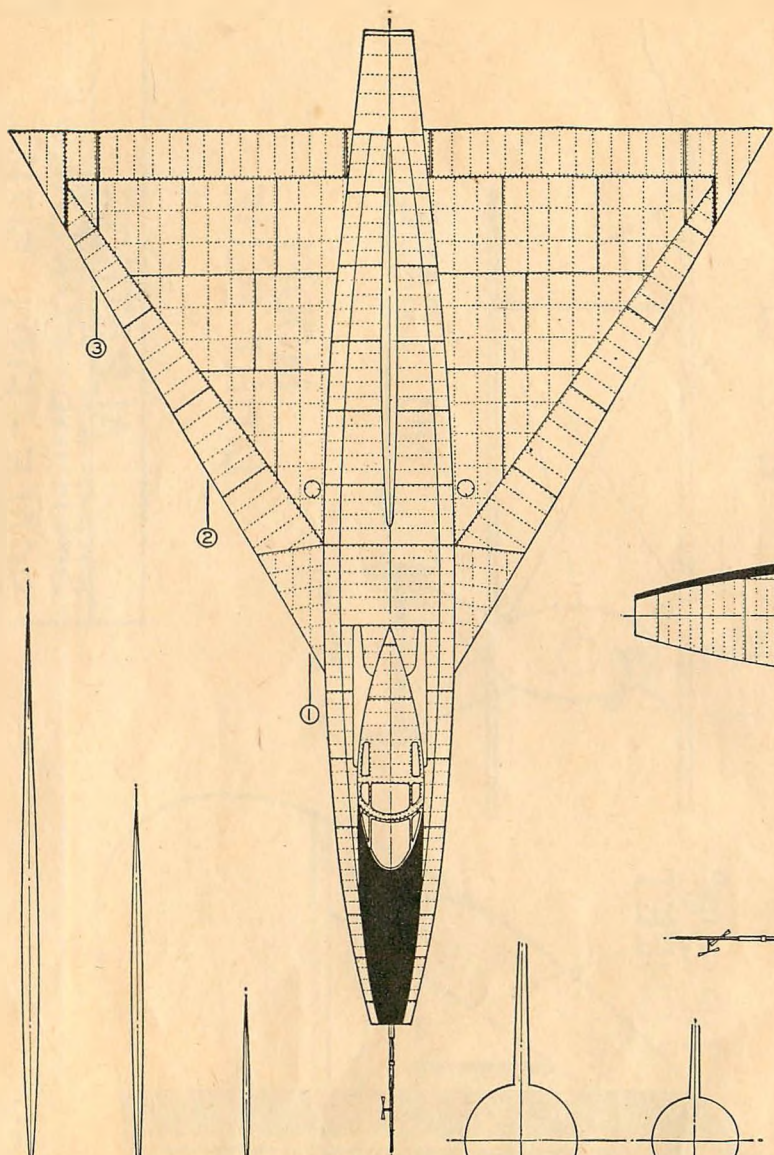

CANOPY DETAIL

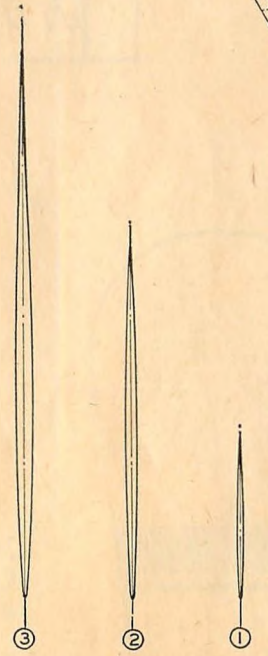
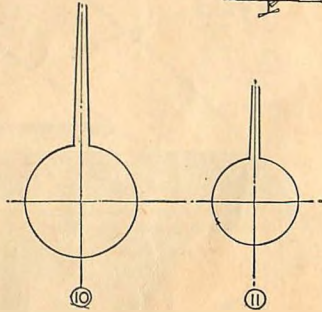
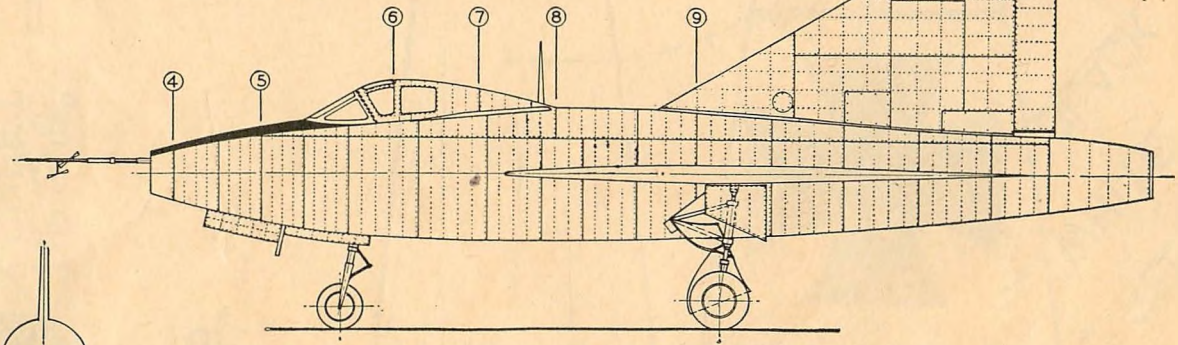

CONSOLIDATED VULTEE  
XF-92A

SCALE - 1/8" = 1'

LEONARD WIECZOREK



# Convair XF-92A

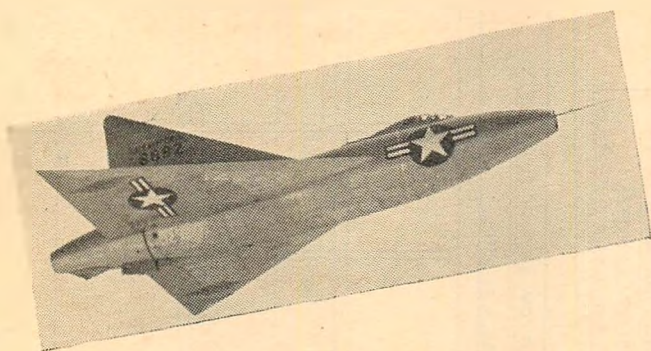

by ROBERT McLARREN

THE august National Advisory Committee for Aeronautics, probably the world's most profound scientific body, made a statement shortly after the end of World War II that seemingly belied its great technical stature in world research. A spokesman for the Committee said: "Airplanes of the future will probably look like the paper darts we used to make in the schoolroom." It was a little difficult for most of us, struggling always to keep abreast of the complex and sometimes utterly baffling hieroglyphics of aeronautical science, to understand such a prosaic pronouncement on what to us, at least, is the most complicated science in the world: aircraft design. But one look at the Convair XF-92A—and we know exactly what the NACA was trying to tell us four years ago!

Your "Plane of the Month" reporter, along with the thousands of other readers of MODEL AIRPLANE NEWS spent hundreds of hours idling sketching airplane designs not so many years ago. And like most other "dream airplane" designers, we have seen many of our designs finally emerge, at least comparable in arrangement in full-size airplanes, with a little glow of pride. No, we were never foolish enough to think anybody "stole" any of our designs because that's how we got most of them! We thought they were pretty bold and daring then but now we realize all we were doing was taking existing airplanes and making rakish improvements on their layouts. Because never, in all the hundreds of sketches, did we ever sketch anything that remotely resembled the Convair XF-92A! Such an airplane arrangement was too fantastic for us, fantastic because such a wing plan simply couldn't fly!

Yet fly, and fly fast and high, it does: this "copy" of a classroom dart! And the reason it does is one of the most interesting stories in aviation, not only of the present but most particularly for the future. Lift is produced by an airfoil through a distribution of pressures over its surfaces: a high pressure on the bottom and a low pressure on the top. This pressure distribution is determined only by the airflow directly across the leading edge. For example, when an airplane skids or yaws, the airflow strikes the wing at an angle. Therefore, this flow is divided into two components: one directly across the wing leading edge and one along the leading edge. Since the component of a force is always less than the force, the lift of the wing is reduced and it drops.

Engineers have made an important application of this princi-

ple in the high-speed flight realm. If we assume that the airflow is at precisely sonic speed, for example, then a component of this flow will be at subsonic speed. Therefore, if a wing could be made to strike this sonic airflow at a constant angle, the flow over the wing would be at subsonic speed, even though the wing was traveling forward at sonic speed! Thus, the concept of wing sweep was born. From this principle it is apparent that the North American F-86A Sabre swept-wing jet fighter can be flying at sonic speed yet the airflow over its wings in the direction across the leading edge is actually at subsonic speed!

The sharp drag rise as sonic speed is approached is created by a tiny shock wave that forms over the thickest part of the airfoil and this speed is called the "critical Mach number" of the wing and, therefore, of the airplane. But with the wing swept back at an angle, it is easy to see that this critical Mach number is not reached over the wing until some time after the airplane speed itself has well exceeded this value. For those familiar with trigonometry, the speed of the air flowing across the leading edge of a swept back wing is equal to the cosine of the angle sweep. (This angle is measured from the center line of the airplane; when measured from a line at right angles to the center line, then it is the cosine of 90° minus the angle of sweep.) Now the cosine of an angle is always equal to less than 1.00, which means in mathematical terms that the flow across the wing leading edge is always less than the free stream flow velocity.

It follows, then, that the more the sweep, the greater this difference. Actually, for 45° sweep the airplane can fly at Mach number 1.5 before a shock wave forms on the wing. And with 60° of wing sweep, a shock wave doesn't form over the wing until the airplane hits a speed of Mach number 2.0, or

(Turn to page 51)





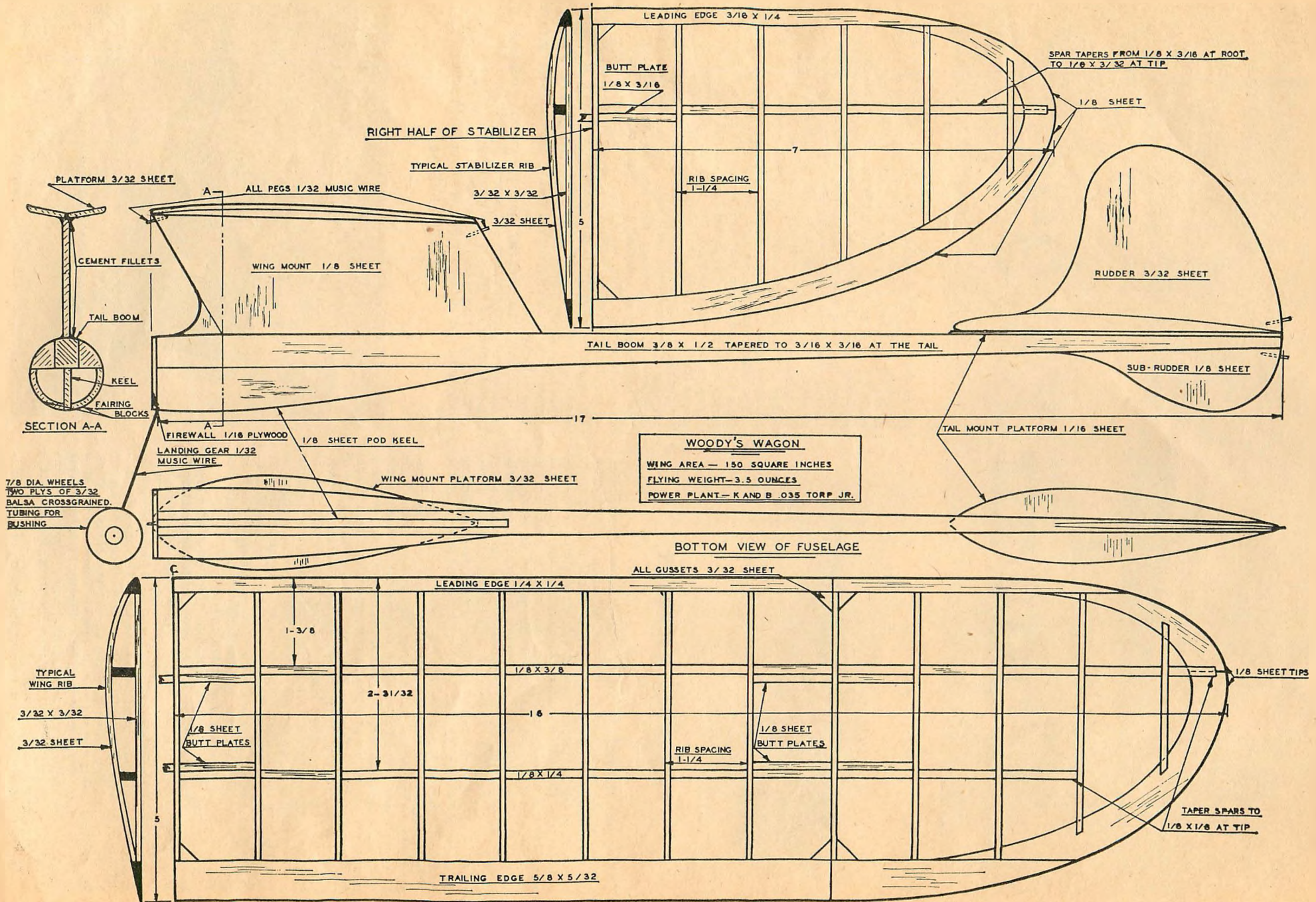

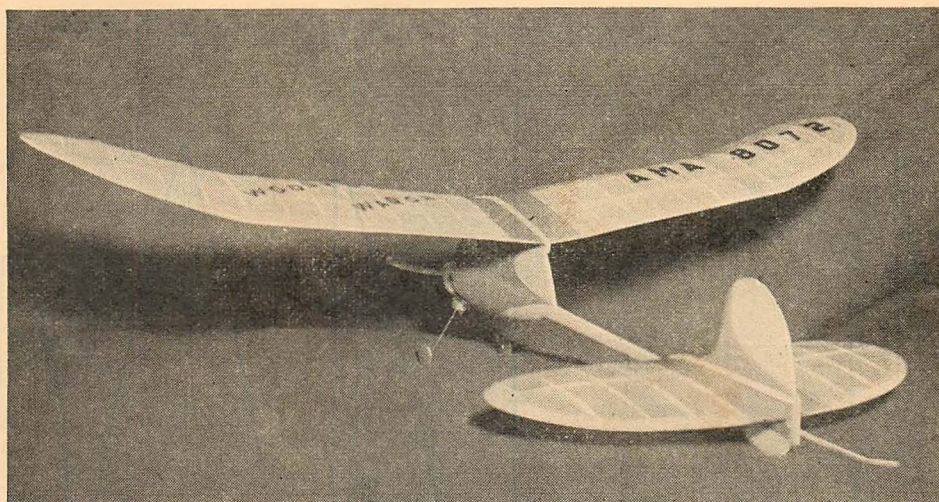

by W. S. BLANCHARD, JR.

# Woody's Wagon

THIS little ship has been designed for top contest performance using the new K & B *Torp-Jr.* .035 power plant. This engine in outward appearance is a scaled-up K & B *Infant*. However, due partly to a change in port design, the power has been increased tremendously. The *Torp-Jr.* will swing a 6" *Spitfire* prop close to 10,000 rpm using *Racing 25* or *Ohlsson AA* fuel. So, with a minimum required contest flying weight of only 3½ oz. under present AMA rules, climb is terrific. And with 150 square inches of wing area, the wing loading is less than 2½ oz. per hundred square inches, which makes for a real thermal-hunting glide.

*Woody's Wagon* is a redesigned version of an O.K. *Cub* powered ship with which the author won first place in the 1949 Middle Atlantic States Championships. Hence, by ballasting the ship up to 4.9 oz., an O.K. *Cub* may be used in this airplane for contest work. Or, at 4.5 oz., the Anderson *Baby Spitfire* may be used.

If you want a fine little contest ship, or a long-lasting sport model to fly on that under-sized baseball diamond, let's get to work. You'll find that this ship goes together in a hurry.

For the fuselage, select a medium-hard, straight-grained strip of 3/8" x 1/2" balsa for the tail boom. Note that the boom ends at the rear face of the firewall. Cement strips of 3/8" x 1/2" balsa to the sides of the boom to form the top of the fuselage pod. Then cement the medium hard 1/8" sheet balsa keel in place. Next, cement the 1/16" plywood firewall in place. Bend the landing gear as shown in the drawings, and attach to the rear face of the firewall, using two short lengths of 3/16" square hard balsa grooved to receive the landing gear as shown. Use plenty of cement. Next, cut the pylon from medium hard 1/8" sheet balsa, and cement in place. Cut the two halves of the wing-mount platform from 1/8" sheet balsa, and cement in place. Go over all these joints several times with cement, forming fillets around the platform and the base of the pylon, and around the rear of the firewall.

Now, lightly cement soft balsa blocks alongside the keel and carve to shape. Then cut them loose and hollow to about 1/8" wall thickness. After cementing the engine mounting nuts to the rear of the firewall with the bolts in place, cement the fairing blocks in place. Cement the tail mount platform and the sub-rudder in place, and sand the entire fuselage carefully.

Wing construction is very simple. First, make a rib template from hard balsa or any other available material. Cut out 26 ribs from medium 3/32" sheet balsa, using the template directly as a guide for your blade. The ribs should have a cross section 3/32" square at all stations.

Cut out the wing tips. Now pin down the leading edge, trailing edge and tips, directly on the plan. Cement 3/32" square strips in place at each rib station. Then cement the two wing spars in place, followed by the upper ribs. The upper ribs should touch both spars, and should be cemented well at all joints. When the wing is dry, remove from the drawing, and build the other side directly on it (bottom to bottom). When dry, cut both sides at the outboard dihedral break, and install the dihedral butt-plates. Assemble the wing with 1/4" dihedral at the first break, and 3/4" at the tips. Sand thoroughly.

The tail is built in a manner similar to the wing. Cut 12 ribs using the tail rib template. Trim the shorter ribs from both the leading and trailing edges. The rudder is cut from medium 3/32" sheet balsa and sanded to airfoil shape.

The entire framework should be very carefully sanded with fine sandpaper. This operation, more than any other, determines whether you turn out fine models or "klunkers."

Cover the wing and stab with light weight silkspan or its equivalent. Apply three coats of plasticised clear dope (plasticised dope is made by simply adding several drops of castor oil to each ounce (Turn to page 49)

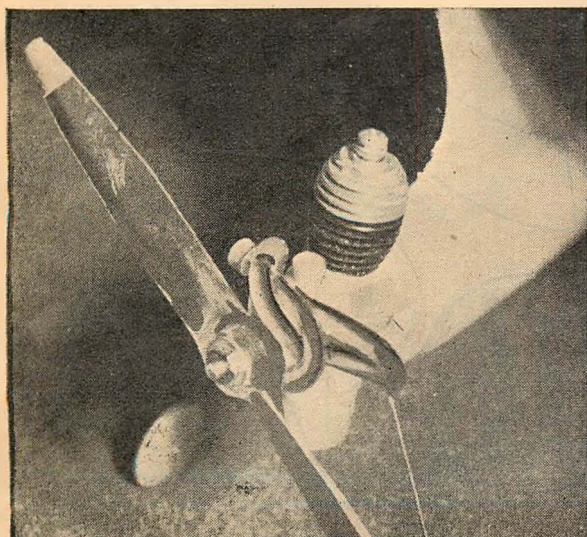
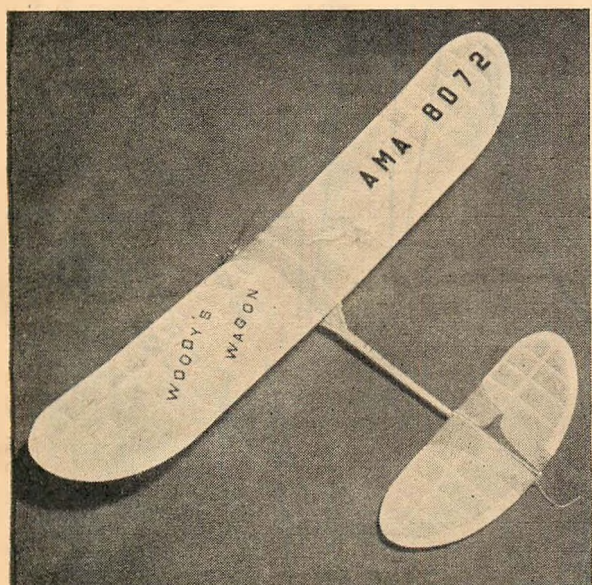

FULL SIZE PARTS FOR WOODY'S WAGON

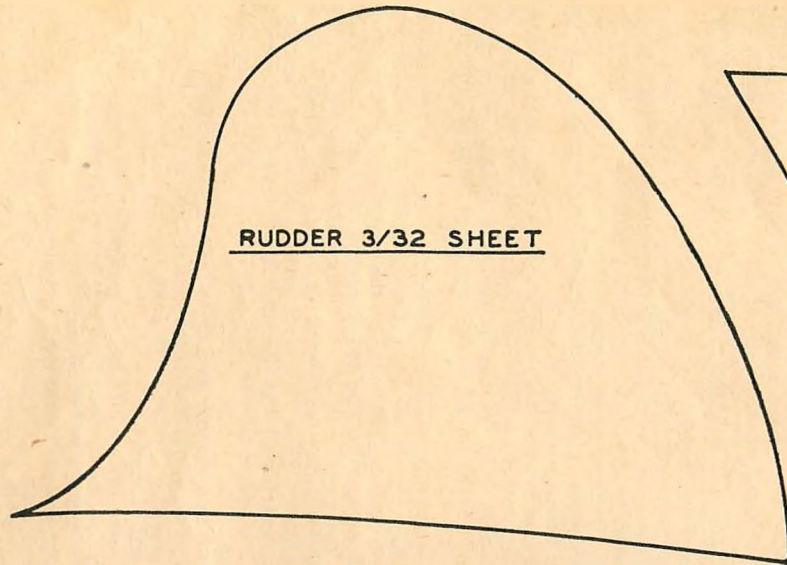

RUDDER 3/32 SHEET

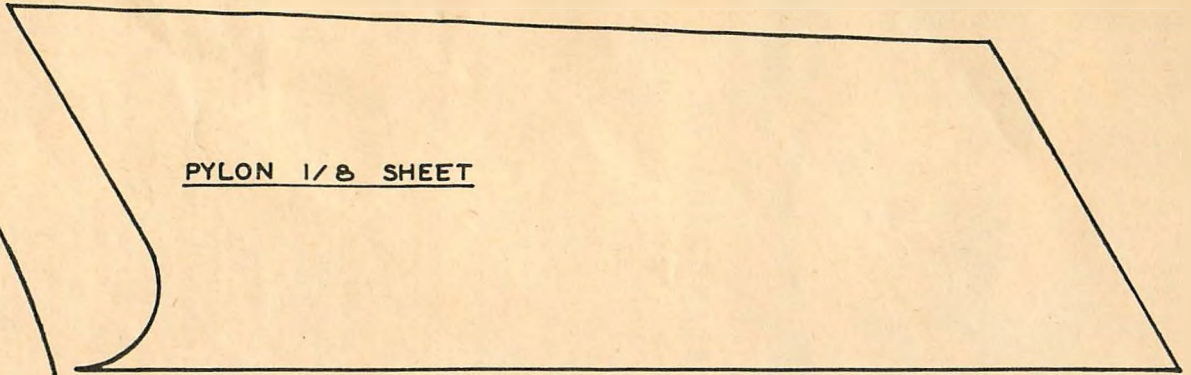

PYLON 1/8 SHEET

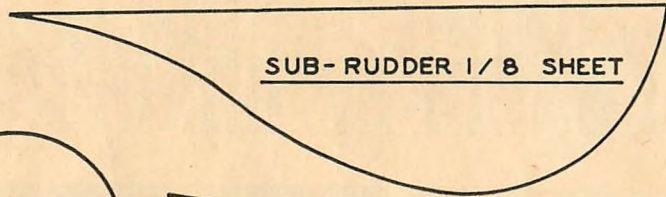

SUB-RUDDER 1/8 SHEET

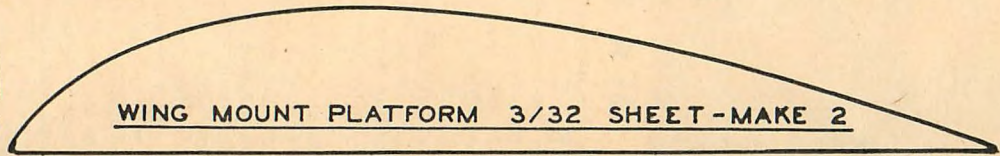

WING MOUNT PLATFORM 3/32 SHEET-MAKE 2

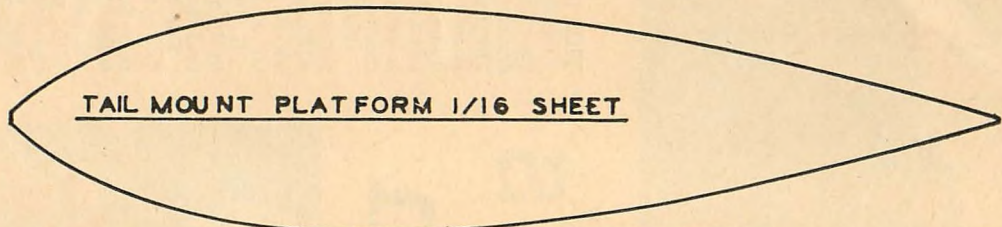

TAIL MOUNT PLATFORM 1/16 SHEET

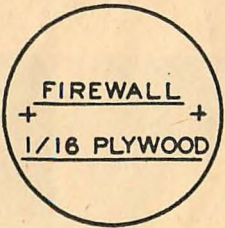

FIREWALL  
+  
1/16 PLYWOOD

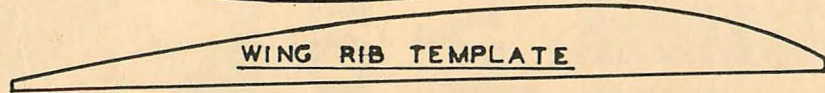

WING RIB TEMPLATE



STABILIZER RIB TEMPLATE

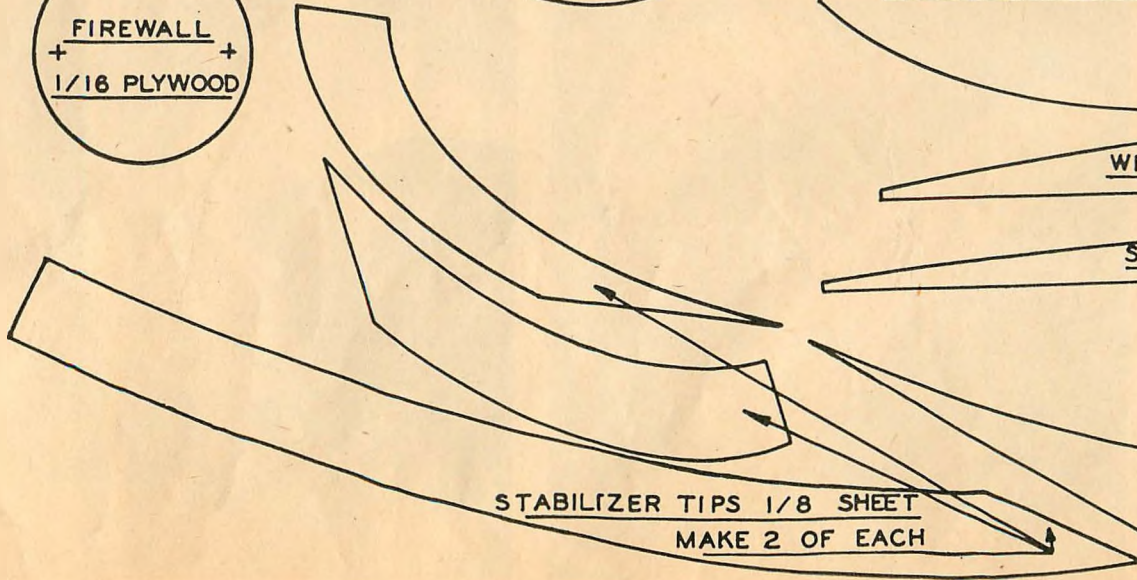

STABILIZER TIPS 1/8 SHEET  
MAKE 2 OF EACH

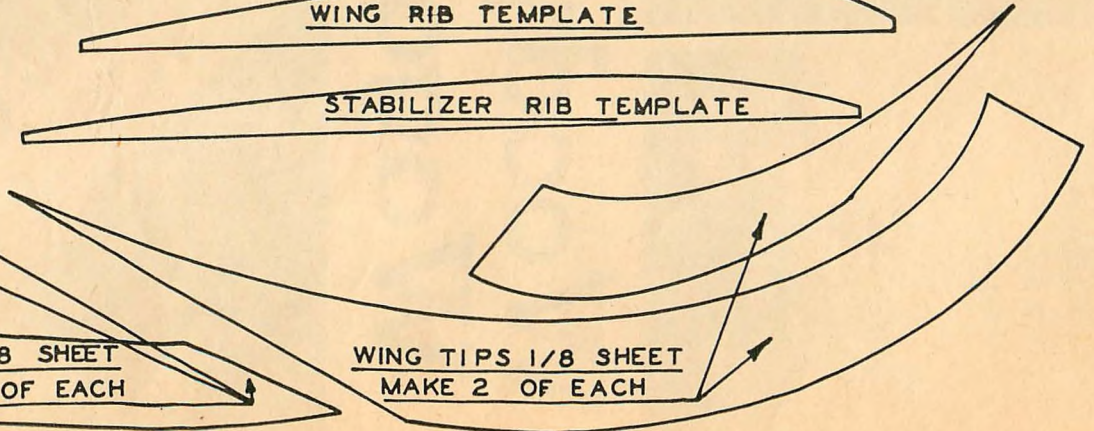

WING TIPS 1/8 SHEET  
MAKE 2 OF EACH

# WORLD WAR I

by ROBERT C. HARE

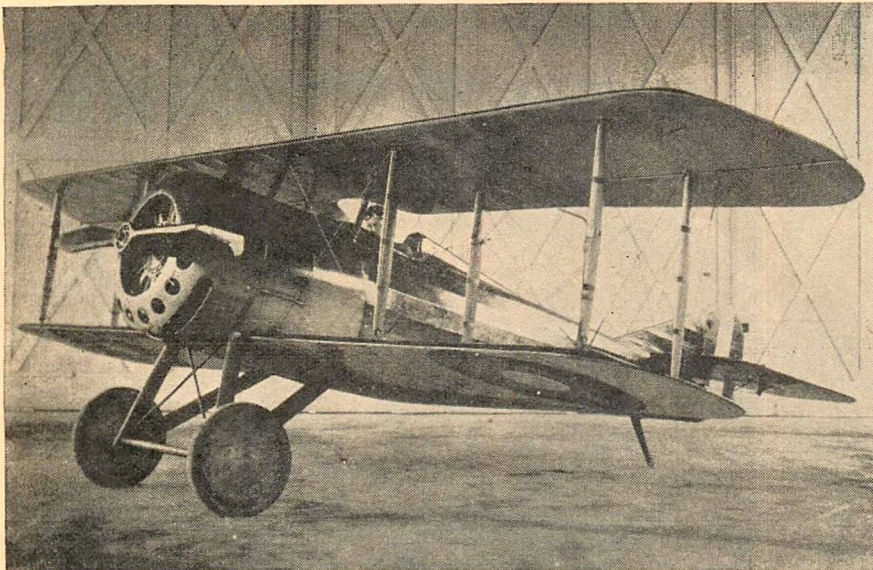

A big engine and careful streamlining gave the Orenco "B" outstanding performance

THE fact that America's aviation engineers of the 1914-1918 period contributed not one original airplane design to the Allied air armadas of World War I often clouds the additional fact that in the United States we still had some of the best brains in the world as far as aeronautical engineering was concerned.

Rapid advances in the art under highly competitive war conditions in Europe had created a situation whereby an Allied nation knew, usually within only a few days, what the very latest advances in German design happened to be. Captured, or shot-down, aircraft were excellent examples of the opponent's latest findings in the science of aeronautics, and any improvements on either side were quickly adapted.

In the United States, however, the situation was entirely different. Before our declaration of war on the Central Powers in 1917, no belligerent nation dared give us information that would permit us to keep abreast of European developments. In a sort of fog of ignorance, our engineers, perfectly capable of designing aircraft of the finest type, still could not do so because they lacked information regarding needs of the moment.

The situation eased but little, even after our entry into the conflict. True, certain Allied types were brought to this country for our engineers to examine, and from them they learned many detail lessons. But it was well towards the middle of 1918—too late, as it turned out, to do any good—before the very latest types were offered as examples of the latest in fighting aircraft.

A good example was the single Nieuport 17 which the French sent over here in mid-1917 and which was flown in exhibitions at Mineola, Long Island, New York, late that year. The Nieuport 17 was nearly a year obsolete at the time, and had been superseded in most French squadrons by 180 hp Spads, or the Nieuport 28.

In any event, our engineers thirsted for knowledge and

know-how. They drank in every rumor, every bit of information; put two and two together, and came up with approximately four.

Our World War I airplane this issue shows how close our American engineers came to at least equalling the best the European nations could produce. When one considers it was done without first-hand information, because of secrecy, it is all the more remarkable.

ORENCO. Orenco was the trade name of Ordnance Engineering Company, a company engaged in experimental and contract work for the U. S. Army. Chief aeronautical engineer for the firm was an American aviation pioneer, Walter H. Phipps, who was responsible for many early U. S. designs. Orenco formed its aviation department early in 1916, when the demand for training planes overseas caused the Allies to look to manufacturers in this country for a supply.

The first Orenco airplane was a side-by-side biplane trainer known as type "A." The plane was characteristic of the period, looked like a cross between a Jenny, an Aeromarine, and a Standard. Only a handful of the type "A" was manufactured, and most of them wound up in the scrap heap because the Jenny proved to be too much competition for foreign markets.

Walter Phipps, however, soon busied himself with designs for a little pursuit plane, which was known as type "B." The Orenco "B" was on the drawing boards in mid-1917, and the prototype flew early in 1918. It was admittedly inspired by the Spad 7 which was in production while the "B" was in design, and that similarity can be seen from the accompanying photos. Structurally and performance-wise, however, the similarity ended there, for the Orenco "B," with less power, could out-everything the Spad 7 (it did in actual tests in this country). This was one of our nation's few bids in the fighter—not advanced trainer—class that was thoroughly tested and ready for production during World War I.

ORENCO "B" DETAILS. The Orenco "B" was a typical unequal span biplane, with its wings braced by two sets of struts on each side, somewhat unusual for a plane so small. Its over-all length was 18' 10"; upper wing span was 26'; lower, 23'; and wing chords were respectively 4', and 3' 9". Wings were gapped at 44½", and were staggered 12"; incidence of the upper wing was 2°; lower, 1°, and there was no dihedral in either wing.

The upper wing was made in one piece with twenty-five ribs mounted on two box spars. Each lower wing panel had ten ribs, including the butt rib, and was attached directly to the fuselage.

Ailerons were fitted only in the upper wing. Interplane struts were of streamlined wood, wrapped with tape and attached between the wings by English type steel shoe and foot fittings.

The empennage was as simple and straightforward as the rest of the plane, consisting of fixed vertical and horizontal

(Turn to page 35)

Similarity to the French Spad is apparent in this side view





Gene Stiles holds ship which broke Straight Line Speed record

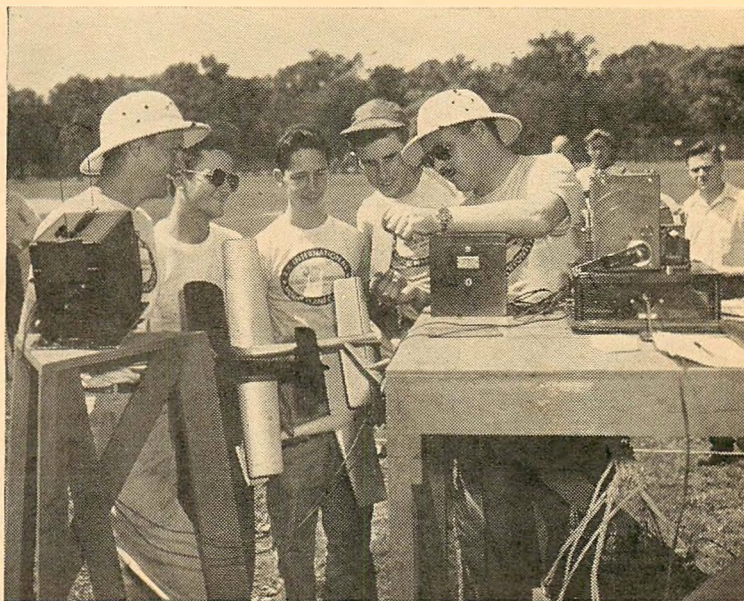

Contestants Hartlieb, Baker, Fitton, Hallum, with timer V. A. Luce, at Detroit

# World's records are tough!

By ED YULKE

**T**HERE'S a whale of a big difference between a National Record and a World's Record; by comparison, setting a National Record is a cinch. The paper work alone for confirming a World's Record is something that will startle most model builders. Photographs are needed of the course, and of the model, surveying must be done and certified, exact plotting of the courses is necessary, and last but not least is the electronic timing requirement.

Sound like a lot of work to go through for a record? It is, but to hold a World's Record, having beaten the best efforts of other modelers all over the world, is well worth the effort. Ask the five boys in this country who in the last six months have set new World's Records! Their chests are out a mile and they have a right to have a few popped vest buttons, for not only is the recording tougher than anything else in model flying, but the actual handling of the models through a record attempt is more difficult.

Perhaps you've set a National's Record in Controline Speed . . . you had a Contest Director of the AMA and two other fellows timing you. A paper is filed with Washington that states the type of plane, make of engine, a few other pertinent facts, and if someone hasn't beaten your speed during the few weeks it takes to get confirmation of your record, you have it. With a World's Record, it takes a book full of proof of compliance with the F.A.I. Rules, then you have to beat the previous record for controline speed by at least 10 mph!

This may all sound very discouraging, but keep in mind that with a National Record, we have only the model fliers here in this country competing for those honors—fellows who all fly pretty much under the same rules. With F.A.I. World's Records, flights made in all parts of the world, under all sorts of conditions, must be properly evaluated to make certain that everybody is flying under the same rules, the same conditions, and that these varied attempts can be considered competitive.

Until 1949, U.S. modelers have been entirely too complacent about World's Records and who held them. Until 1949, not one actual World's Record was held by the U.S. except when

we held the Wakefield Trophy. Now we hold five World's Records, Free Flight Speed in a straight line, Controline Speed in Classes I, II & III, and Jet Controline Speed.

The U.S. Navy and the Plymouth Motor Car Company sponsored experimental record trials at Alameda, Calif., in June, 1949, for Free Flight Speed models flown in a straight line. This sounds simple when you say it fast—but it isn't. All our free flight models have been designed and built for duration with corkscrew, or at least high-angle, climb under power. At Alameda though, the model had to keep a low altitude and every bit of torque had to be compensated for, since the model was required to fly a distance of 100 meters (328') between two markers 100' apart. This naturally required quite a different model was required to fly a distance of 100 splitting the sky at our contests or Record Trials. Hank Struck and Bill Effinger collaborated on the design of the ship that Eugene

Stiles used to set the new record; it was a tricycle-gear job powered by an Atwood *Triumph* engine. F.A.I. Rules call for maximum of only .61 cu. in. displacement, so most of our racing Class D engines were eliminated. Wide latitude is given insofar as areas and wing loadings are concerned, the maximum area for International Records of any type being 16.14 sq. ft. and the wing loading between 3.93 oz. per sq. ft. and 16.38 oz. per sq. ft.

The worst part of flying straight-line speed in free flight for the World's Record was the "return trip." The rules state that the course must be flown both ways and the second trip must be made within 30 min. of the first. This calls for a quick hand with a tube of glue, because flying at 80-odd mph a few feet off the ground with a ship that has a high wing loading doesn't lead to gentle landings. Many of Gene Stiles' flights were fine in one direction, then went off-course on the upwind leg. The record, still subject to official verification in the Paris, France, headquarters of F.A.I., is 81.587 mph, over 15 mph better than the 9-year-old Russian record.

When the F.A.I. recognized circular speed flight (or controline to you) early in '49, it was inevitable that the U.S. should be the first to set such records. Controline speed is one of the backbones of the model hobby here in America, yet there still were sufficient differences to make it a not-too-easy task to set up marks for the other countries to shoot at. First, the models must fly longer than our AMA rules call for in that every flight must be a full kilometer (approximately 5/8 mile). This means 14 laps for Class I (37' lines), 12 laps for Class II (43' lines) and 10 laps for Class III (49' lines). Then, too, for a World's Record attempt, the flier doesn't just drop his cap

**FLASH ITEM:** As we go to press, unofficial word has just reached us that a special category has been established by the F.A.I. for models with Jetex power. Watch for further details which will appear in *MODEL AIRPLANE NEWS* as soon as received.

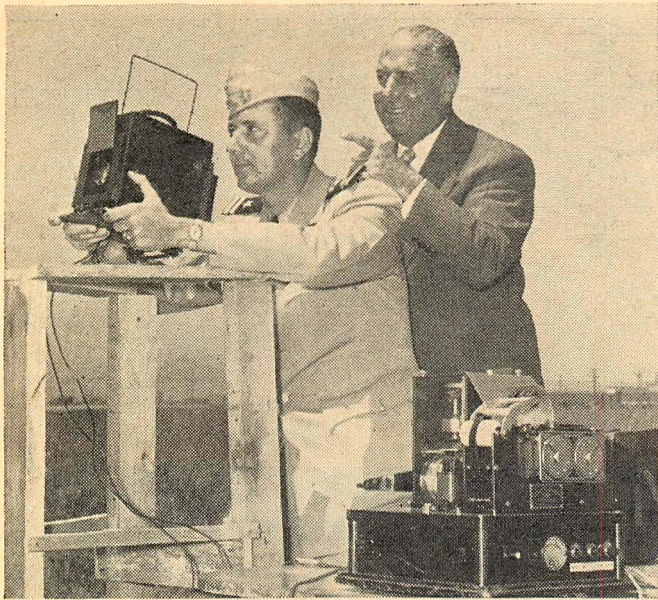

Lt. J. Burton, USN, and R. Somerville, of Plymouth, check timing equipment



Bob Rawe holds F.A.I. Class A Speed record, and Tom Baker won out in Jet

when he wants the timing to begin—he must state beforehand on which lap he wants the timers to start clocking him! One rather innocent-looking rule which can and has caused trouble in flying is that the model is required to fly above the flier's hand at all times. One dip during the timing and the flight is ruled out!

Class I posed a bit of a problem at the Third Plymouth International Meet in Detroit where the controline record attempts were held. The displacement for the engine used must not exceed .15 cubic inches. Bob Rawe, of Kenmore, N.Y., who set the new World's Record for Class I with a speed of 99.30 mph, solved that little problem by sleeving down a McCoy .19 engine. Bob Veasey, of Wilmington, Del., who set the Class II record at 128.28, and Bob Hartlieb, of Lebanon, Pa., with his Class III record of 142.16 mph, had an easier time of it . . . they used standard engines of .29 (5 cc.) and .61 (10 cc.) displacement. All the planes were conventional with the exception of larger gas tanks to take care of the longer runs required.

Since these records must be beaten by 10 kilometers per hour (6.2 mph), for new World's Records, it is not likely that they'll tumble for a while. Tom Baker of Kings Mountain, N.C., set a Jet Category Record of 144.83 mph that will be hotly competed for by England's *Juggernaut* jet engine, closest in competition ability to the *Dyna-Jet* that Tom used.

One of the most interesting F.A.I. rules that has been set up is one stating the model may be controlled and held by a handle as we are familiar with, or attached to a pylon. A few years back, various modelers all over the country were experimenting with various types of pylons from which the model would fly itself. Some used two lines, much like the control handle arrangement, but with the lines fastened to a pylon a short distance apart. This gave automatic stability to the model, since as it dropped down, the up line pulled the elevator up and brought the model back to a predetermined height. Not much has been heard of these developments lately and modelers are requested to write MODEL AIRPLANE NEWS of any experiments along this line. One idea we had heard of was to have just one line or wire, with electronic control for the elevator, thus reducing line drag by 50%. This last idea, either as a pylon or hand-held idea would cause a jump upwards in the speeds of all types of controline models if the "receiving device" in the plane was light enough to be practical. In the F.A.I. Rules, provision is made for a pylon in which the flier's hand must rest during timing. This was developed a few years ago by Tom Herbert, of White Plains, N. Y., and has become almost universal in use for speed timing throughout the modeling world.

While the U. S. holds the most popular records, there are many other categories that will prove of interest. The Federation Aeronautique Internationale has basically four categories for World's Records: I—for Land Type Planes; II—for Hydroplanes (float jobs); III—for Special Aircraft such as flying wings, tailless models, helicopters, etc.; and IV—for Gliders. They recognize three types of power, rubber, gas and jet. In rubber, there are four sub-categories: (a) for duration; (b) for distance in a straight line; (c) for altitude; and (d) for speed in a straight line. These same groups are recognized in Gas Free Flight and in what is called *Telecontrolled* flight where

(Turn to page 53)

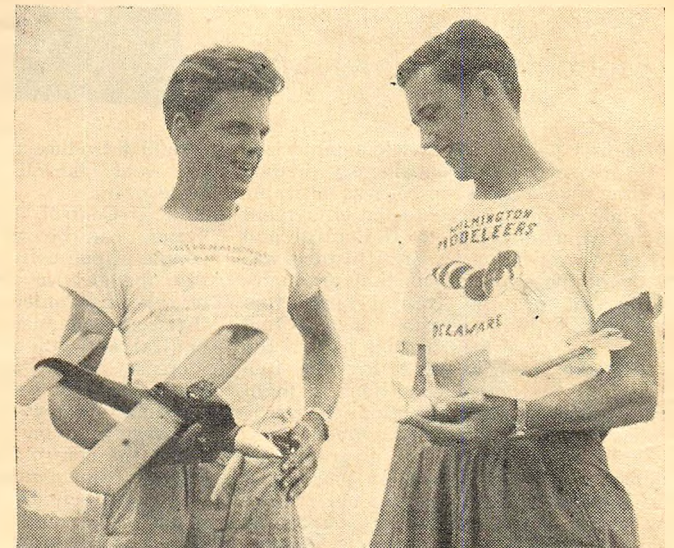

Bob Hartlieb, (left) Class D winner, with Bob Veasey, Class C top man



Lt. Burton (left), Plymouth's A. B. Dowd, and others watch Stiles warm up

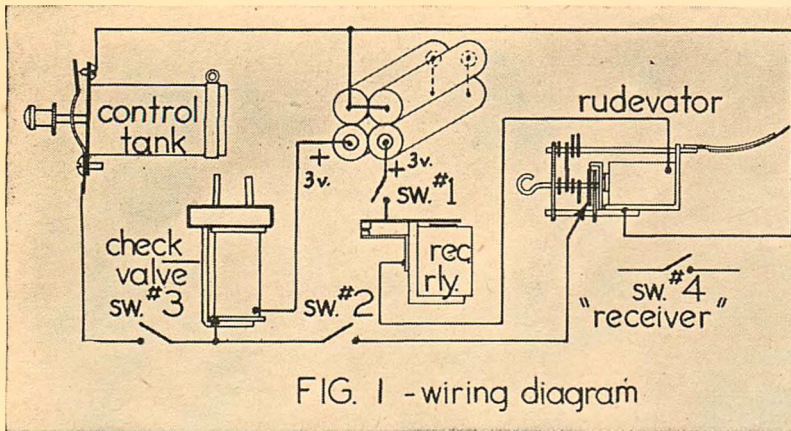

FIG. 1 - wiring diagram

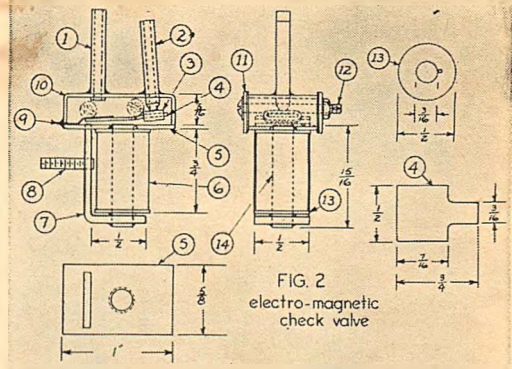

FIG. 2  
electro-magnetic  
check valve

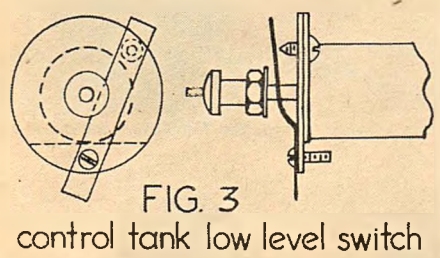

FIG. 3  
control tank low level switch

# power control

By H. H. OWBRIDGE

## PART TWO

THE first half of this article summarized the reasons why a satisfactory method of glow plug engine control was desirable and how it could increase the enjoyment to be gained from both U-Control and radio control flying. A brief history was given of the experiments that gradually led to the present "control tank" fuel system and the operation of this fuel system was described. In this half of the article the methods of fitting the fuel system to the actual conditions of flight will be discussed and directions for fabrication and operation will be given.

For review, study the diagrammatic sketch of the fuel system on page 23 of the December, 1949, issue. Fuel follows the arrows from the filler tube to the main tank, then through the electromagnetic check valve to the control tank and then to the engine needle valve. When battery current opens the check valve, fuel under pressure in the main tank moves the piston of the control tank. This motion opens the engine throttle valve and at the same time, by means of a light spring in the control tank, increases the flow of fuel to the engine so that a satisfactory mixture is maintained. The flow control clamp between the check valve and the control tank is used to regulate the rate at which the engine goes from idle to full power. The time it takes for the engine to go from full power back down to idle is regulated by means of the stroke of the control tank piston. As the control tank empties, the return spring closes the throttle valve. The hose clamp shut-off between the control tank and the needle valve is added so that it is not necessary to disturb the needle valve adjustment in order to shut off the fuel system.

The fuel system is exceptionally easy to handle and most of its components are designed from readily available parts. The other parts are easily fabricated with the exception of the check valve which might take a little more patience. A wide variety of adjustment is available to suit individual requirements. Although primarily developed for radio control, this fuel system lends itself well to U-Control and

should introduce the maneuver of "land, taxi and take-off" into the U-Control scale event.

In U-Control, the control tank fuel system can be operated two ways. A couple of pen cells can be made to energize the electric check valve by means of a spring contact on the bellcrank so that contact is made somewhere between neutral and full up elevator. Thus, to increase power, the control handle is hauled back or eased back depending on the flight speed at the time. Low power is achieved by flying level for a few seconds while the control tank piston moves in. Proper adjustment, of course, is all up to the individual and his particular airplane. A second and fancier method would be to rework one of the relays that were intended for two-speed control on the old spark ignition engine. These relays are of high resistance and suitable for use with high-voltage batteries through insulated controlines. The relay can be reworked into an electromagnetic check valve by following the plan of Fig. 2. This should prove easier than using the dimensions of Fig. 2 since it would eliminate the necessity of winding a 1,500-ohm coil. The insulated controline method, although more expensive, has the advantage of separating the power control from the flight control.

This fuel system is well adapted to a large fuel supply because cut-off is assured and if failure occurs, it fails safe. For instance, if batteries run down, the electric check valve cannot be opened so the engine runs out of fuel in 30 to 60 secs. or less depending on the control tank stroke adjustment. If a large size Austin flight timer is used for the main tank, experience shows this to be a 4- to 5-minute fuel supply for an Ohlsson 19 engine. All engines will differ a little so individual experiment is necessary. If 4 min. is not enough for U-Control, then two Austin timers may be connected in parallel. An even better main tank can be found in the several types of rubber bulbs available at drug stores or photographic shops. These will be discussed later. Let's analyze the fuel system from

the radio control viewpoint.

As mentioned before, the control tank fuel system has many features that are ideal for radio control flying. Engine cut-off is a natural as is safety cut-off in case of a runaway airplane. The available rpm range on glow plug is well beyond what was possible with the spark ignition engine. This is largely due to the inherent retarding of the point of ignition as the glow plug cools down at low speed. Low rpm sounds something like "ke-puckity puckity queep" and is quite amusing.

The fuel system blends in very well with a cyclic type of control such as the Rudevator, in which all controls must be passed through whether wanted or not. The inherent and adjustable time delay action of the control tank allows the power control position (we use neutral after down) to be passed through with negligible effect on engine speed. The amount of thought necessary to regulate power in flight is much less than might be expected. For the most part, one can forget about power control until it becomes a main issue in the flight pattern. It calls for a simple habit to be formed whereby the operator goes through the neutral after down position at a normal rate. This automatically transfers a quantity of fuel from the main tank to the control tank and keeps the engine floating within a narrow rpm range. It is not necessary to hear the engine. If the ship appears to be steadily losing altitude then it is obvious that the neutral after down position is not being dwelled on long enough in passing through. It is a simple matter to return to this position and boost the rpm a little. On the other hand, if the ship appears to continually gain altitude, neutral after down is being passed too slowly and the operator should get through it faster on the next few turns of the control handle.

What about when it is desired to hold minimum rpm for a long time while making a long descent? Since the control tank will be almost empty at minimum speed, must we worry about it running out and leaving us with a dead engine?

The answer is no, because a simple switch similar but lighter than the one that came on the Austin timer is installed on the control tank. Just before the tank runs dry this switch closes and pops the check valve open. The control tank gets a pip of fuel which moves the piston out a fraction of an inch and immediately opens the switch again. This process goes on automatically so that at minimum power we can forget about the engine. It will run at minimum power until the main tank runs dry.

But now we have no cut-off. After all the discussion about cut-off that has gone before, it seems a shame to inform the reader that there is no such thing if the minimum level switch is used on the control tank. But who cares. If that engine is going "ke-puckity puckity queep," that airplane is coming down! The same goes for runaway safety cut-off.

Here is another good question. Suppose we were to lose contact with the airplane while the Rudevator was in the neutral after down position. The check valve would be energized open and the engine would go to full power and stay there. This could only happen on one neutral out of four but it could happen. The solution to this problem requires no extra gadgets. We simply apply a little more than the required pressure to the main tank so that when the control tank is out against the stop with the check valve stuck open, full main tank pressure is being forced fed to the engine. This will give a blubbering rich mixture and the engine will either die or it will gulp the whole fuel supply so fast that the ship won't be able to run very far.

This extra pressure on the main tank serves another useful purpose. With the ship at a distance and the engine difficult

to hear, the operator could have the control tank filled to the stop and not realize it. At one time, another control tank switch was thought to be necessary to prevent this. Not so in practice. If the control tank is against the stop and you try to get more power by dwelling on neutral after down, the trail of blue smoke from the rich mixture will soon indicate the condition. However, this case has little reason to occur unless the operator is just plain throttle happy. As mentioned in the previous article, the fuel system can be juggled to suit.

Fig. 1 shows a typical wiring diagram. It too can be juggled. Switch No. 3 is thrown in just in case you might want to try a flight with the control tank minimum level switch inoperative and thus have complete cut-off available. Four pen cells are shown as a minimum battery supply. Notice that half of the pen cells go to the Rudevator and half to the power control. This is in case you get caught in the air with low batteries sometime. It's all right if the check valve can't be opened but we wouldn't want the Rudevator to quit. For U-Control of course, the wiring diagram is much simpler and since the engine can always be heard, even the control tank minimum level switch can be omitted if desired. Switches 1 to 4 of the diagram are best made from dress snaps as mentioned in a previous article (Oct. '49, MODEL AIRPLANE NEWS).

Fig. 2 shows how an electric check valve is made. Brief comments on parts and construction follow. Numbers refer to the circled part numbers of Fig. 2. (1.) Inlet tube—1/8" brass or copper soldered in cover as shown. (2.) Outlet tube—same as 1 except lower end is

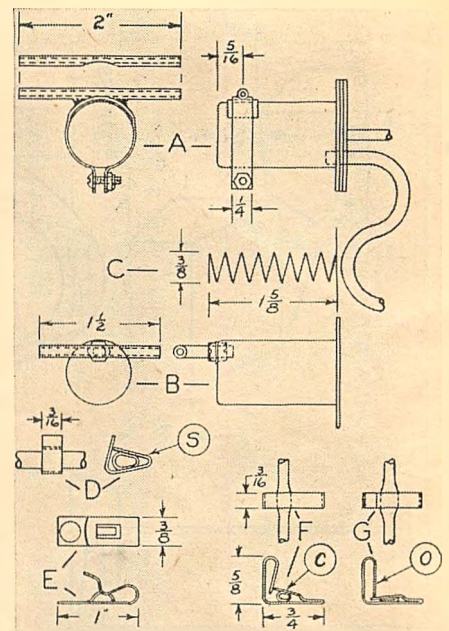

FIG. 4  
some all-important details

**Further details on constructing and operating a flexible fuel system for glow motors**

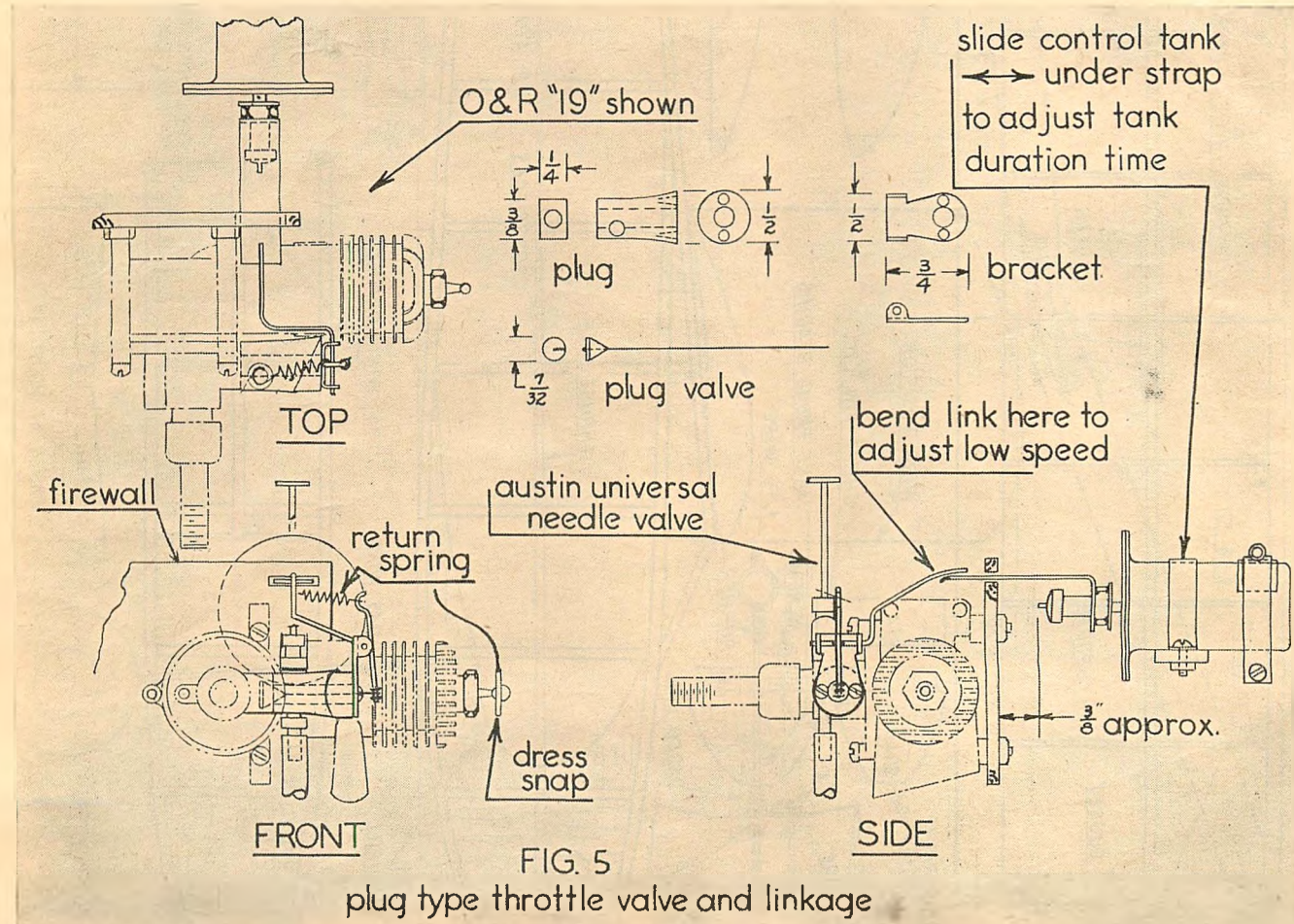
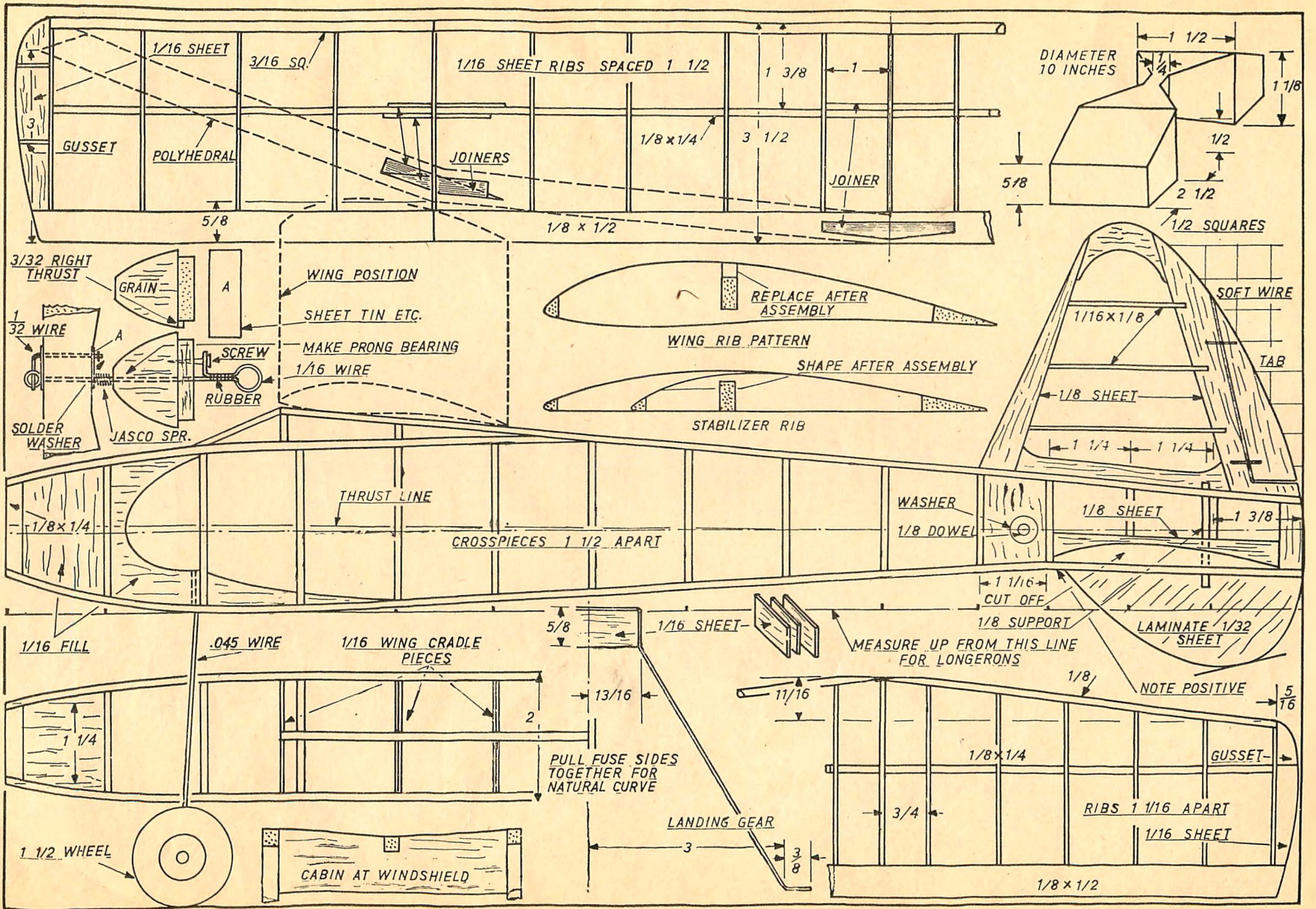
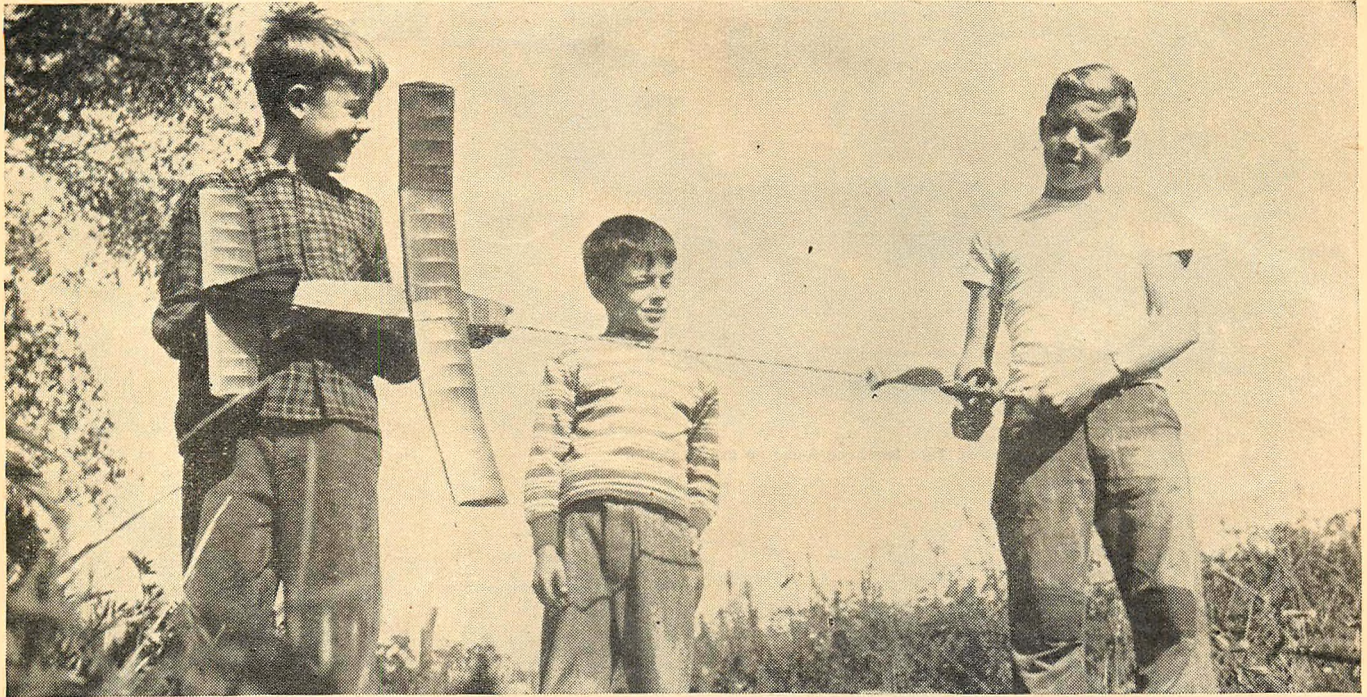

FIG. 5  
plug type throttle valve and linkage







# wakefield trainer

by BILL WINTER

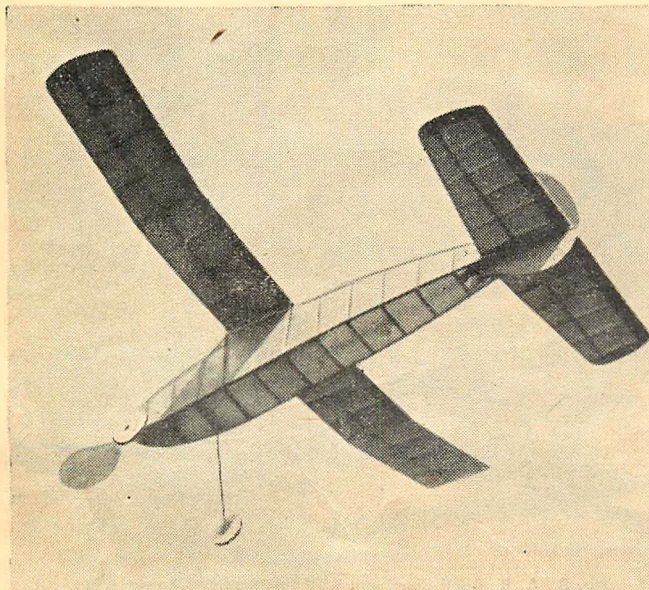
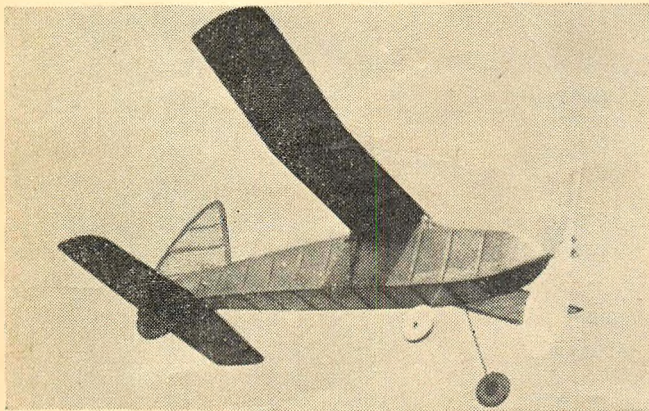

**W**HY is it that model aviation does not have the equivalent of the basic trainer? If you disregard the sport model, a rather occasional airplane built with no performance specifics in mind, there seems to be nothing but the beginner's model meant for kids who are about to make their first glue joint and, at the other end of the scale, the high performance contest types that only a limited few can handle capably—if at all.

The model basic trainer type is a much needed airplane. Its advantages are almost too many to list. Its main purpose is to permit mistakes without wash-outs or even damage, yet without stripping away the satisfaction of having a machine capable of controlled exciting performance, and not mere flying as with the beginner models. Essentially, this is not a beginner's model; yet any beginner, having made his first powered model, can make the basic trainer without difficulty. In making it, he will be introduced to many of the small points that mark a rubber contest job. And, while he can learn to fly it properly, to make adjustments to get it to fly better and better, flight after flight, without the proceedings being terminated by a spiral dive which we all make sooner or later, he will be able easily to think ahead of the airplane.

There is no reason either why any flier, expert or otherwise, should be ashamed (who is ashamed of piloting an AT-6!?) to take out a miniature Wakefield—for that is what it is. With 10-12 strands of 3/16" rubber it is a bundle of dynamite for its size and can be flown like any contest model in small areas.

Among its features are such good contest-type items as a separate stab and fin, the stab being a unit fixed in place. The fin is an integral part of the fuselage so that it cannot be accidentally moved or in any minute way vary the adjustments. This makes for consistent flying. Wing and tail incidences are built in, as is downthrust. The rubber attachment and tensioning are essential for anyone who really wants to learn how to fly the big duration types. The fuselage is sturdy, reinforced about the nose, again as any reliable ship must be if it is not to fold up from the banging about of test flying and windy weather landings. A folder was not used because the purpose was not to duplicate all Wakefield features, but to take the tyro up to the point of successfully flying the big models; moreover, a free-wheeler is a step in that direction for it permits reasonable glide. Structure throughout is on the heavy side, for the elimination of warps is absolutely essential to accurate adjusting. Undercamber is used since the covering is a bit more difficult than on a flat bottomed section and because undercamber almost always distinguishes the contest types.

(Turn to page 32)

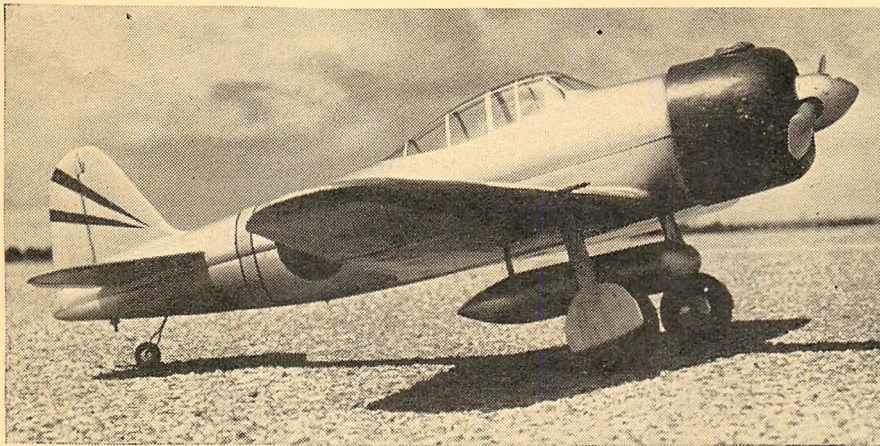

No. 1 Robert Haack's Jap Zero has been found an excellent flier

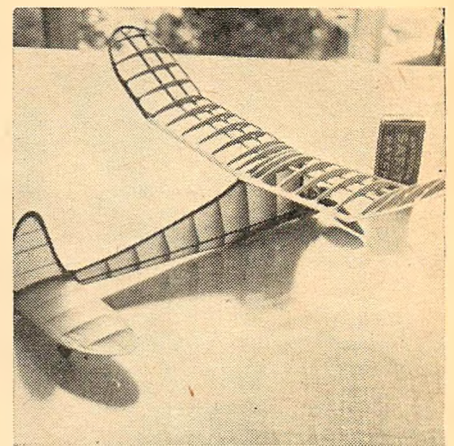

No. 2 Tiny CO2 free flyer by Charles Thure

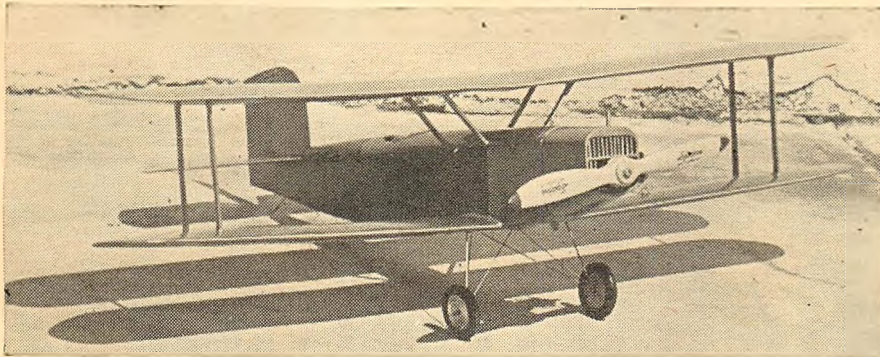

No. 3 Dusty Carter gets a big kick out of flying this scale Boeing Mailplane



No. 4 Julio Dumo launches his Wakefield

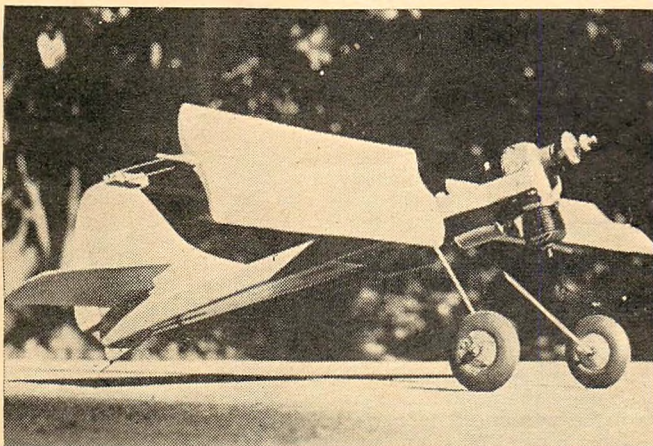

No. 5 Dave Jones is a rotor plane enthusiast. This one does very nicely

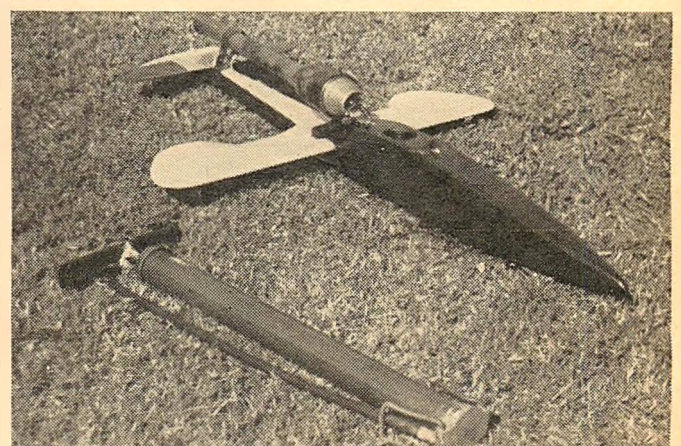

No. 6 This jet speedster is work of Cpl. Don Mattingly

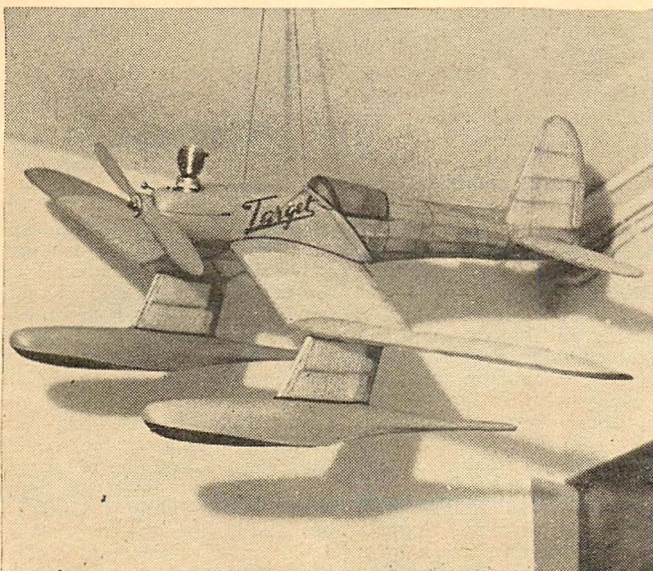

No. 7 Thaj Frolund hopes for a record with his float job

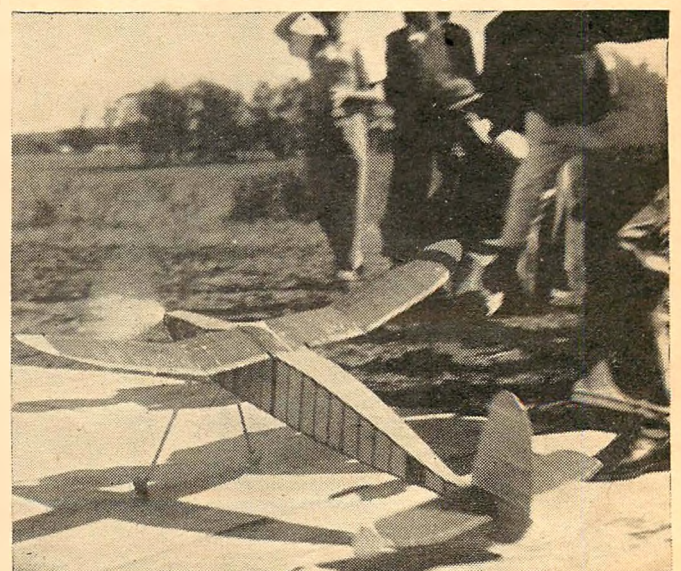

No. 8 A. B. Abell does well with this modified Korda Wakefield

# air ways

News of Model Airplane Experimenters All Over the World

**B**ACK IN the October, 1949, issue, in our write-up of the 1949 Nationals, we noted that among other misfortunes that had befallen famous personages at the Meet, Maurice Roddy, Aviation Editor of the CHICAGO DAILY TIMES AND SUN, was taken seriously ill and was rushed to a hospital in Chicago by plane. As we left Olathe, word came that Maurice was recovering nicely, and in fact, after several weeks at the hospital, he was well enough to return to his home.

We have since received the sad news that he suffered a relapse and died late in September.

Maurice was a real booster of model aviation; he conducted one of the first syndicated columns on model aviation to be printed in this country, and he aided in sponsorship of several Nationals Meets that we held in Chicago before the war. He was a strong and consistent supporter of model flying back in the days when model aviation was young and really in need of such support—furthermore, he continued this active support right up until the time he was stricken at Olathe. His fine work in our behalf will live on for many years.

**THOSE SIMPLE** escapements. The escapement used on radio control planes is a simple-looking item, but misadjustment can cause a lot of grief. Commercial escapements are usually in good shape when the flier gets them, but mounting in the plane, connecting rudder linkage, and that irrepressible urge to "touch up the adjustment a bit" often lead to trouble. Hints on escapement adjustment are given on page 12 of this issue, and owners of both commercial and homemade jobs are urged to study the principles involved and apply as necessary.

Utilizing the ideas included in the article mentioned, the author, Jack Luck, will follow up next month with all the dope necessary for production of an escapement which is light, simple, and reliable. This unit will be of the three-arm type, a design never seen in commercial jobs, but one that offers a lot of advantages.

**F. A. I. RECORDS.** If readers gain the impression from reading the article on pages 24 and 25 of this issue, that we are endeavoring to increase interest in F. A. I. Record making, they are absolutely right. Now that the ice has been broken and we hold some of these records, we can't just sit back complacently on our new laurels. Other countries will be spurred to action by our success in 1949.

It will be apparent that gaining an F. A. I. Record is quite different from going out on a Sunday afternoon with a few of the boys, to shoot at some of the AMA records. But right now is the time to start planning, building, and testing planes in the categories that interest you. It seems certain that the Officials and facilities necessary for F. A. I. Record attempts will be available at some of the large regional meets in 1950, as well as at the Plymouth Finals and at the 1950 Nationals. Don't wait for the announcements of these World's Record Trials therefore, but start NOW on the necessary preliminaries, and be all set to grab yourself a World's Record in the coming year.

**NOW THAT** copies of MODEL AIRPLANE NEWS, both new issues and back ones, are once more circulating all over the world and reaching areas where they have not been received in some cases since 1940, we have been asked to correct a case of mistaken credit. Back in 1940 or so, Mr. Hans Justus Meier, a well-known German aeromodeler, translated an article on propellers from the then-existing German model magazine MODELFLUG and sent it over here for the personal use of M. A. N.'s editor. The original article had been written by the noted German aerodynamicist, Dr. Alexander Lippisch.

Later on, through several misunderstandings, the translation was reproduced in the September, 1943, issue of MODEL AIRPLANE NEWS but was credited to Mr. Meier, who was simply the translator. Many back issues of M. A. N. are now reaching Germany, and to make certain that Dr. Lippisch or anyone else will not feel he falsely claimed credit for this article, Mr. Meier has asked that we set the matter straight.

The scale boys are represented first this month with a slick copy of the Jap Zero, built by Robert Haack (302 Peck Avenue, San Antonio, Texas). It is powered by a Bullet engine, and has a span of 40", weight 2 lbs. 4 oz. and a top speed of 55 mph.

(Turn to page 38)

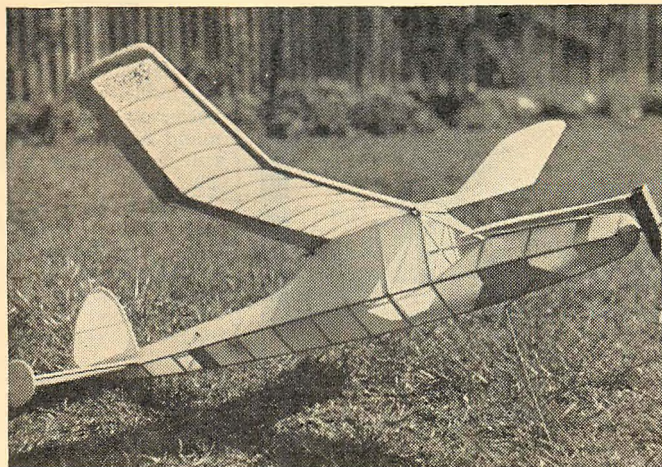

No. 9 Lightweight duration model built by K. G. Miller

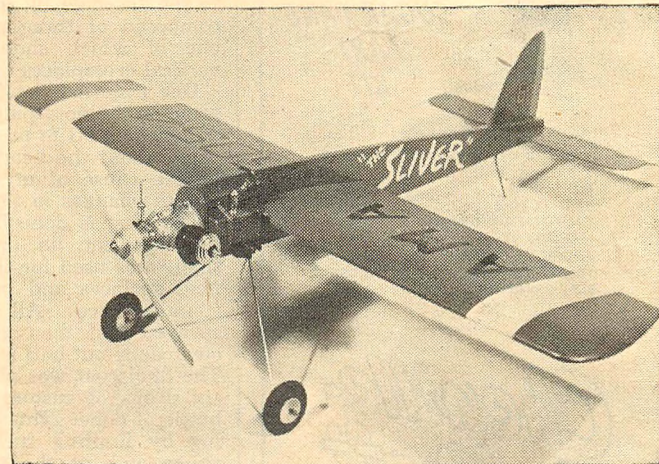

No. 10 Marty Lihl's stunt job weighs just 15 oz.

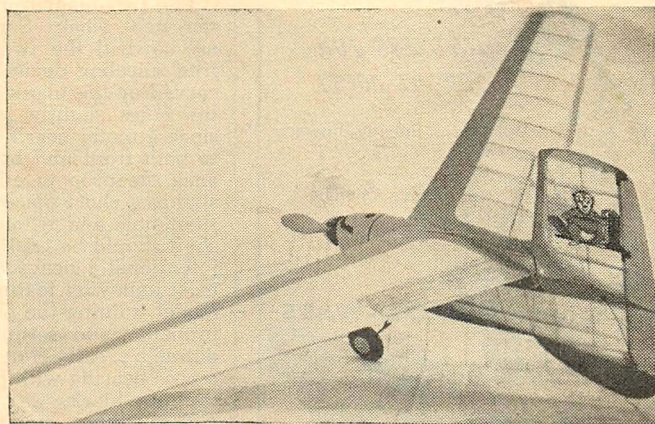

No. 11 Swept-forward tailless design is the work of Blaine Parkin

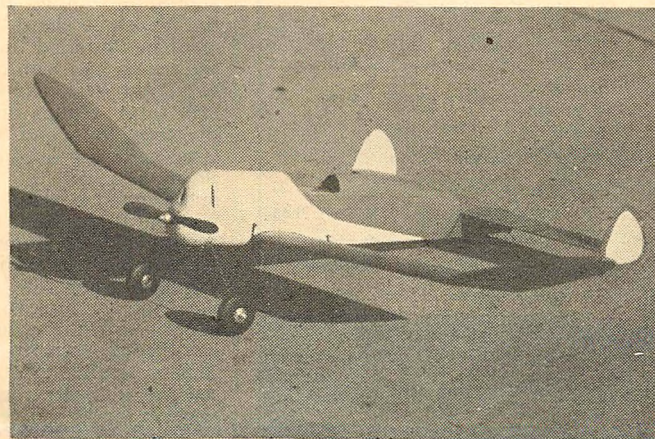

No. 12 Very successful low wing sport wing belongs to Eduard Breland

Dealers!



Johnny Clemens Says

TRY THESE

# CRAFTS

FOR PROFIT and FUN!

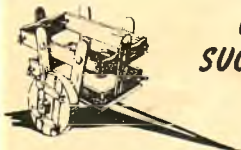

## CUBAN SUGAR CANE CART KIT

This Is the Cutest Thing We Have Ever Carried

WHITE PINE . . . . .	\$2.45
KNOTTY PINE . . . . .	2.45
CALIFORNIA REDWOOD . . . . .	3.45
MAHOGANY . . . . .	3.45
AROMATIC CEDAR . . . . .	3.45
YELLOW POPLAR . . . . .	3.45
BLACK WALNUT . . . . .	3.45

# Chenille-Kraft



LIMITLESS FUN FOR ALL AGES!

Make clever animals, flowers, toys, party favors . . . . .

Colorful, pliable Chenille-covered wire

\$1.00 per set

Write for Sample

# Froom HOLLOW-WARE COPPER



For Tooling, Etching, Fluting or Painting

	Coaster, 3 3/4" dia. . . . .	\$ .25
	Ash Tray-Coaster, 4 7/8" dia. . . . .	.35
	Bread and Butter Pl., 6 7/8" dia. . . . .	.65
	Candy Bowl, 8" dia. . . . .	1.30
	Fruit Bowl, 9 1/4" dia. . . . .	1.35
	Dinner Plate, 9 1/2" dia. . . . .	1.25
	Serving Plate, 11 3/4" dia. . . . .	1.55

Dealers . . . . . Regular Discounts  
If no dealer include 15c for postage.

JOHN E. CLEMENS  
2114 Greenville Ave.  
DALLAS 6, TEXAS

## Wakefield Trainer

(Continued from page 29)

Detailed building directions of the put-down-the-wax paper type hardly are necessary for anyone who already had made his first built-up model, so we'll run through the highlights of this basic trainer.

The fuselage is made of 1/8" square. Use medium, but not hard, wood (your full size Wakefield would use 1/8" to 5/32" square hard balsa with closely spaced crosspieces). The side frames are easily joined at the wing position, after which the rear end is pulled in with a natural curve and the crosspieces added. The nose may be held in with rubber bands while the 1/8" x 1/4" front pieces are installed. Note the sheet construction at the stabilizer position and, as filled in, at the nose and between the front crosspieces. The landing gear is attached to the fuselage by means of a sandwich composed of three plies of 1/16" sheet, one of which should fit between the vertical crosspieces of both fuselage sides.

One essential detail is the direction of grain on the nose plug. This grain should be fore and aft to prevent crushing of the wood about the bearing. This latter can be the cause of mysterious poor flights due to changes in thrust adjustments.

Covering is done before installation of the stabilizer, fin, or under-fin. Purple tissue was used for the fuselage and vertical surfaces and orange for the horizontal surfaces. All covering was water-sprayed and then given three coats of clear dope cut half and half with thinner. The final coat was plasticized with about six drops of castor oil to a two ounce bottle of dope. This will help stop warping by limiting further pulling of the paper and, at the same time, adds an attractive gloss to the finish.

The two-bladed propeller is cut from a ten-inch block. Some helpful pointers are to drill the two holes (one for the free wheeling device) before the block is carved or the blank even cut out. Make the holes slightly larger than the wire since a metal bearing plate will be glued to both front and back of the hub. Balance the prop to eliminate vibration by sliding a short piece of wire through the shaft hole and trimming as needed. The shaft should be 1/16" music wire. This is intentionally heavy. Bent shafts are the most annoying feature of any big rubber model, ruining the proper tracking of the propeller and setting up vibration that detracts greatly from performance. Make a nose bearing with points for insertion in the nose block.

The rubber motor is made up of at least ten strands of 3/16" rubber, and should be double the distance between the hooks, or about 28" long. This motor must be "braided." First, drive a nail in the bench and loop one end of the motor about the nail. Now separate the motor into three groups of strands—for example, four, four, and two; or, if you use 12 strands, into groups of four strands each. Stretching out the rubber about three feet beyond normal, wind each group 25 winder turns and begin to braid the groups. (Mama knows all about braiding—check her for technical details.) Have a helper work the braids in toward the nail, not jamming them together, yet not leaving everything loose. Slide a clothes pin through the free end of each group. This is something every man has to find out for himself; you'll need four hands and six fingers on each hand, but don't let it get you!

Finally, stretch each end of the braided

motor and, while stretched, wrap tightly with a rubber band. Rubber lube (try Jasco) may be put on now. If homemade lube must be used, mix green soap and glycerine (from the drug store) to a honeylike consistency. Cup some in your hand and soak the rubber in it well. Wind the motor outside the ship a few dozen times and let run down to throw off excess lube. (But not on the wall paper!) Wipe lightly if the motor threatens to drop or throw gook on the sides of the fuselage. Insert the rubber through the shaft hook then close and bind the hook with a strand of rubber. Check the tensioning by winding the motor a few dozen turns (of the winder) and allowing to run down. The spring on the shaft will move the prop forward as the rubber runs down until the right-angle piece of the shaft engages the screw. If this happens too soon and with many turns remaining (too much tension adds tremendously to fuselage loads in a crash), move the screw in a half turn and try again. Or vice versa. The idea is to stop the motor without the rubber falling onto the bottom of the ship or with bunches of rubber forming haphazardly to change your C.G. and dive or stall the glide. The nose block should remain snugly in place.

Your finished model will be in approximate trim if similar materials to those specified have been used. To balance, it is not recommended to move the wing back and forth. Instead, use pieces of sheet balsa beneath the leading or trailing edge of the wing as necessary. Place in front if the glide is too fast, or in back if the glide is slow and stall. The ship is designed to come out of its climb slightly fast. This is always a good beginning, since a sliver of wood or matchbook paper will correct the glide. After adjustments are found, glue in such packing.

Due to the line-up of fuselage with wing and tail—all desired incidences being built into the frame—the ship will need no downthrust. Downthrust refers to the actual thrust line relative to the wing. While the plan appears to show upthrust, the plane really has considerable built-in downthrust and any more will make it nose down into a dive when flying at high speed under power. Start flying with 1/16" sheet inserted behind the left side of the block to get right thrust and increase this to 3/32" if necessary to get tight power turns. The rudder trim tab is bent slightly right to begin flying.

To adjust, hand glide the ship over grass, if possible from some elevated object like a rock or chair. The proper glide will be fairly fast with the ship following a straight line at a shallow angle toward the ground, not flattening out for a pretty three-point landing. You want the ship to land forward on its wheels all the time and not three-point. A tiny bit of right turn in the glide—just enough to notice—is desirable. If the glide is too fast, slow it up with a piece of packing under leading edge of wing.

Assuming you have a 4-1 winder, use about 35-50 turns for the first flight. Have a helper hold the ship while you stretch out the rubber a few feet to wind. Don't throw the ship but launch dead ahead in level flight with a smooth gentle motion and with just enough force to avoid the ship hitting the ground. If the plane stalls or dives badly, you have something out of line, probably the thrust line and, if you can't spot the trouble, use upthrust to avoid the dive and down-

(Turn to page 34)

# INSIST ON *America's Finest Model Airplanes* GET ★ CLEVELAND ★ KITS FOR CHRISTMAS

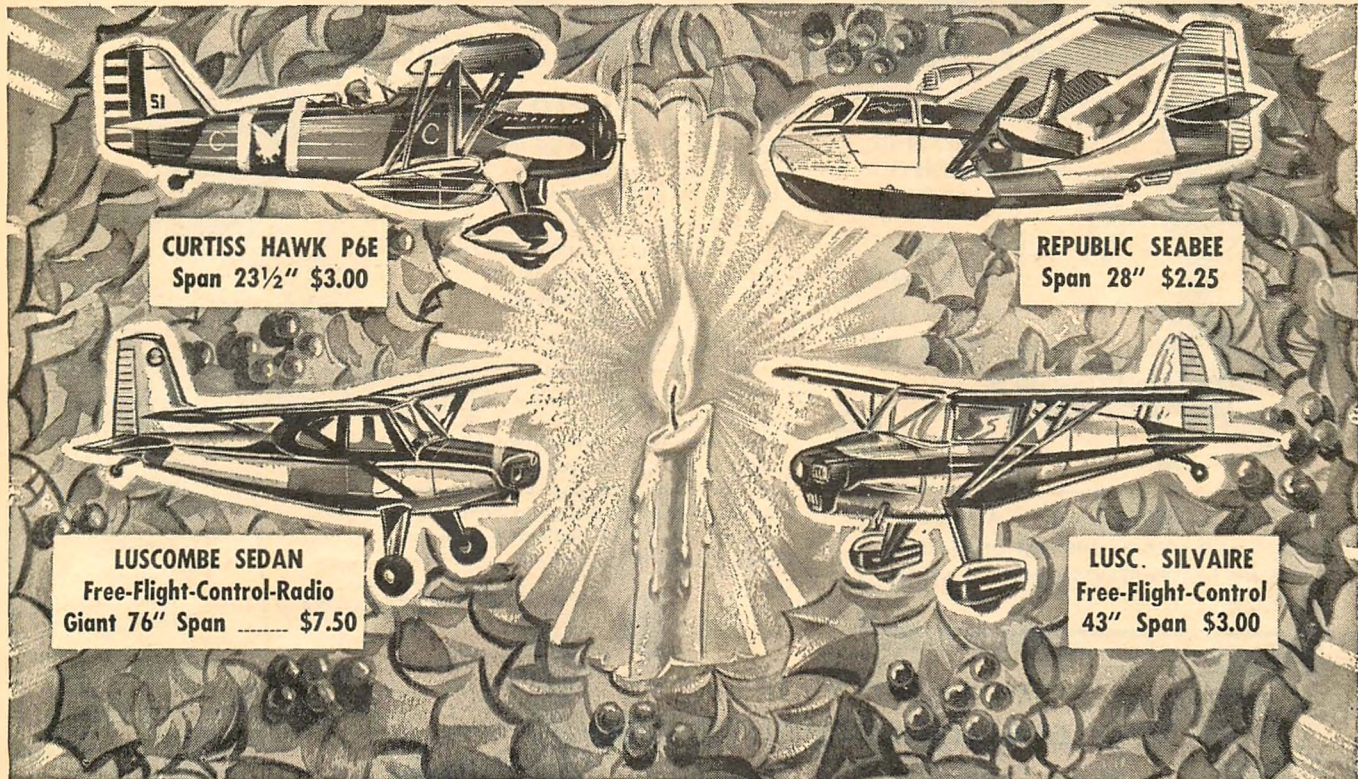

**CURTISS HAWK P6E**  
Span 23½" \$3.00

**REPUBLIC SEABEE**  
Span 28" \$2.25

**LUSCOMBE SEDAN**  
Free-Flight-Control-Radio  
Giant 76" Span ..... \$7.50

**LUSC. SILVAIRE**  
Free-Flight-Control  
43" Span \$3.00

## For Rubber And Miniature Glow Plug Or C-O-2 Motors

**50c** If ordering direct, get at least two to fill \$1 minimum order.

**20" span  
AERONCA SEDAN** ★

**18" span  
BRITISH WWI SE-5**

★ **20" span  
BEECHCRAFT BONANZA** ★

**16" MIDGET MUSTANG**  
**20" FOKKER D-7**  
**16" THUNDERJET**

**50c "E-Z"s ARE DIE-CUT, LIGHT, & TAKE MANY MOTORS**  
These simply built, lightweight models have all the flying ability of much larger models.

**F-38 LIGHTNING** ★

## THRILLERS WITH ½A MOTORS!

FOR: GAS --- C-O-2 RUBBER!

Big 3 Ft. Twin Jobs

EACH  
KIT  
\$2.00

**F-61  
BLACK WIDOW**

**CHOOSE THE BEST — CHOOSE CLEVELAND FOR EVERY TASTE**  
Cleveland-Designed flight-engineered, super-detailed kits come in all sizes and prices, for all uses. Space restricts full description of these fine models. You can't go wrong when you buy from the oldest "same management" model aircraft kit manufacturers in the world. Our 30 years of designing assures good flying results! Ask old-timers about C-D's! Send 5c or two 3c stamps for very latest illustrated catalog.

**CONDOR**  
6 ft. \$1.00

**LANCER 32" \$1.00**

**CONDOR**

**30" SPAN  
DOLLAR  
MODELS**

**FLEETSTER 32" \$1.25**

**F-61 BLACK WIDOW**  
49½" \$14.50

**Pick Your Next Miniature Glow Plug Kit From These Specially Selected Free Flight Designs. SWELL FLYERS!**  
They're real "floaters" with the K&B "Infant", and are really hot performers with "Cub" or "Spitfire"

**HOW TO ORDER:** See your local hobby dealer first. If he does not have these kits, do not accept substitutes but order direct. Include 25c for pack.-post. (35c West of Rockies, APO's and U. S. Possess.) Min. order \$1.00 plus postage. No C.O.D.'s accepted. Special Delivery in U.S.A. only, 25c extra. Foreign countries add 20% for special handling, etc., in addition to 25c pack.-post. charge. (Ohio residents: add 3% sales tax.)  
**SEND 5c OR (2) 3c STAMPS FOR ILLUSTRATED CATALOG**

**CLEVELAND MODEL & SUPPLY CO**  
★ **4516-A1 Lorain Avenue** ★  
★ **Cleveland 2, Ohio U. S. A.** ★

# GET IN THE LEAD WITH ATWOOD ENGINES!

## OFFICIAL WORLD'S RECORD HOLDER

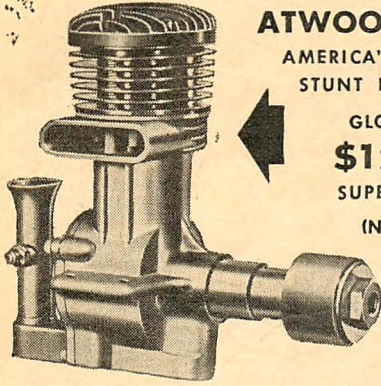

**ATWOOD "60's"**  
AMERICA'S LEADING  
STUNT ENGINES!

GLO DEVIL  
**\$12.50**  
SUPER CHAMP  
(Not Shown)  
**\$14.50**

THE NATIONAL POWER PLANT **ATWOOD**  
STOCKED AND SOLD BY THE BEST OF DEALERS.  
WHERE NO DEALER SERVES OUTLYING AREAS,  
ORDER DIRECT . . .

### A VERY GOOD YEAR!

Focus your glimmers on the records, folks.  
Look at 'em. It's Atwood power, top,  
bottom and upside-down.

Atwood engines helped take first, second,  
third and fifth places at the New York  
Mirror Meet. Stunt championship  
at Plymouth Internationals.  
Flying scale champion-  
ship at the Nationals.  
Hundreds of additional  
records throughout the  
country at this, that or the  
other meet. No matter how you filter the  
winning news, folks, you come up with  
Atwood power. Top dog—Blue Ribbon—  
Grade A—In at the finish—No matter how  
you rate 'em—it's Atwood here & there for  
proven performance—proven popularity.

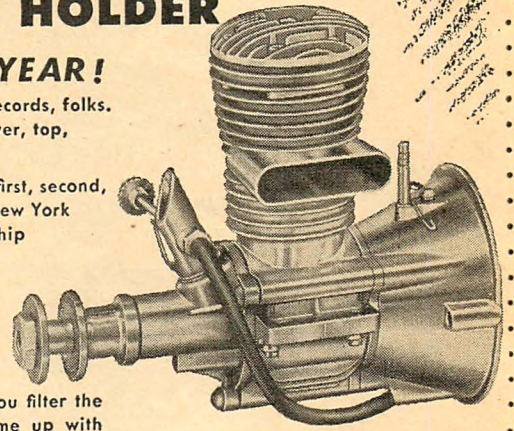

### Free-Flight!

(1950 Models)  
**ATWOOD 49-51 GLO**

Same as world's  
record holding engine.  
Furnished with sensa-  
tional, new "B & B  
MICRO TANK"

**Only \$14.95**

### U-CONTROL!

(1950 Models)

**ATWOOD 49-51 GLO**  
Same as world's record  
holding engine. Furnished  
less tank and glo plug.

**Only \$12.95**

... "YOUR MONEYS WORTH" ...  
**ATWOOD MANUFACTURING CO.**

4738 S. Durfee Road, Pico, California

thrust to avoid the stall. However, this is for drastic cases only. The first thing is to get the glide correct, for nothing will be right with the glide out of trim. See if the ship dives or stalls in the glide. Be sure stalls are not continued after a bad stall at the end of the power run.

Note whether the glide is a right turn as desired. Is it so tight a turn that a dive would result? Then open up the turn. If it is too straight, add a bit more trim tab, remembering that tightening a turn will tend to remove a slight stall and opening up the turn will tend to induce a stall. For example, a slightly stally glide that is straight should be corrected with rudder and not by taking out incidence in the wing.

Once the glide is okay, remove power stalling tendencies by downthrust, and vice versa. Get the proper turn with the

use of right-thrust and again remember that tightening a turn tends to make a ship dive, opening it up, to stall. When you have it right and fully wound, the ship should fly out about ten to 30' in a straight line beginning a flat climb, then starting to nose up steeply and bank around to the right. At about half a circle the ship should nose further up and slow down for a steady climb. If too tight a turn is being used, the model will continue on around from that half turn position striking the ground practically at your feet. If the model appears sluggish and yet has enough power, play a bit with the trim. Eventually, you will find the model flying cleanly and with a world of zip. As you improve, adjustments keep adding rubber turns. When using capacity winds, stretch the rubber out at least 5' from the nose.

### Scrap Box

(Continued from page 8)

the time originally anticipated. I had hoped for a minimum of 2 hrs. 20 min. After some modifications to the plane, I shall try again." To prove this isn't fiction, Bernice sends a picture of herself and the ship. Both are good looking, too. You know, the fuel manufacturers will love this. Bernice, you aren't married to one, are you?!

With which this rocky balsa butcher is going to take refuge in the peace and quiet of the tall-but-true story department. (Who was that bewhiskered gent with the lantern who just peered at us and shook his head?) Hmmm . . . True folder. Nope. Tall folder. Nope. Tongue-in-cheek folder . . . Must be a whopper . . . Two quarts of fuel . . . 1.121 laps inverted . . . Ah, here's one—and the blame is all yours, dear reader, for needing the old "Scrap Box." No holds barred!

"Until just before the war, I used to spend my summers on my uncle's farm about 20 miles northwest of Morristown, N.J.," begins Bill O. Passarelli, Jr., Brooklyn, N. Y. (Don't you love the quiet build-up?) One day I was out in the fields flying a hand-launched glider and on one launch, it hit a riser. Off I went, but lost sight of it over a neighboring farm.

"Late in August a farmer returned the model in good condition except for a couple of warps—nothing unusual about this. But then I asked him where he found it. The model, after landing in an oat field, had laid there until harvest. On harvesting, the model went through the binder and was lodged in the center of a tied bundle of oats. It wasn't until the farmer decided to feed some of the newly harvested oats to his team that he cut the string and discovered the model undamaged inside one of them." Yoicks!

Here you are, Bill, baled and undamaged: one subscription to MODEL AIRPLANE NEWS for the best tall-but-true story of the month.

THE NEW

# ROSS

## JET GLIDER

ALL EDGES  
ROUNDED

HIDDEN  
WEIGHT

DIHEDRAL-CAMBERED  
WING

**AMERICA'S  
FINEST**

10c

ROSS CHEMICAL & MFG. CO., 8459 MELVILLE STREET, DETROIT 17, MICHIGAN

## World War I

(Continued from page 23)

stabilizers, a one-piece divided elevator and a rounded rudder.

At rest, or in the air, the Orenco "B" gave an impression of stubbornness. This effect was produced by its extremely deep fuselage necessary to properly streamline the big engine in its nose.

And in this instance, "big engine" was no misnomer. The Orenco "B" was the most powerful American pursuit plane in the air during its heyday. Its power plant was a Gnome Monosoupape 9N, rated at 160 hp. The engine was enclosed by a typical rotary engine cowl. This roundness was preserved most of the length of the fuselage by liberal use of stringers and formers over a basic box structure of four longerons and numerous uprights and crosspieces.

**ORENCO "B" PERFORMANCE.** When the "B" was brought to the attention of U. S. military authorities late in 1917, it was strictly a private venture—it was produced as a speculation, without government order. By the time the "B" was in the air, the die had been cast insofar as procurement was concerned. The deal had been made whereby the United States would manufacture the DH-4, and trainers, and procure its pursuits from foreign governments. But the "B" was considered seriously in the conferences, because it was capable of better performance all-around, than anything the Allies were in a position to provide for us out of existing stocks!

Top speed of the "B" was 135 mph: 132 at 5,000', 126 at 10,000', and 118 at 15,000'. Time of climb to 5,000' was 3 min. 20 secs.: to 10,000, 7 min. and to 15,000', 15 min. 11 secs. In those days, that was going upstairs in a hurry!

The Orenco "B's" take-off and landing performance would have pleased any front-line commander whose squadron operated from a hastily made airport. On take-off, the "B" ran just 110' before it was airborne, and on landing, only 200' were required from the point of touch-down until the ship stopped rolling. The "B" carried 210 gallons of fuel, which gave it a 202-mile range at full speed.

Its ceiling was well over 20,000', and the prototype "B" was outfitted with oxygen equipment. In addition, the "B" had one of the earliest U. S. service-type radio installations on record—possibly the first in a pursuit plane in this country!

Another feature of the "B," which made it a terrific potential as a fighter, was its novel machine gun installation. This ship was designed, remember, before the U. S. had been guaranteed access to certain European aircraft innovations, such as the synchronization of machine gun fire through the propeller disc. Accordingly, the "B" was intended to carry four machine guns. Two guns were to have been mounted on the under sides of each wing, firing outside the propeller disc, and requiring no synchronization.

You might say the Orenco "B," a plane born of American ingenuity and with a minimum of technical help from nations "in the know," was a victim of circumstances. It certainly was, but it demonstrated the fact that American aeronautical engineers of that day had a great deal on the ball in spite of the fact their brainchildren were produced in experimental quantities only.

Although the Orenco "B" was dropped as a project, it lived through three more developments, models C, C2, and C3, all of which were trainers, each with an 80 hp Le Rhone for the power plant. Type "C" was merely an advanced trainer; it was identical to the "B" except for lighter construction in some features, and a reduction in stagger to 7" to make up for the difference in engine weight.

Type "C2" was a still lighter edition, with a simplified interplane strutting arrangement—one pair of struts on each side. Type "C3" was especially stressed as an acrobatic trainer, had a safety factor of 8 throughout (same as the "B"). The U. S. Army procured six of the "C" models in the summer of 1918.

# This is IT! THE FIRST REALLY MODERN FREE-FLIGHT WITH ALL THE ADVANCEMENTS OF THE LAST 10 YEARS

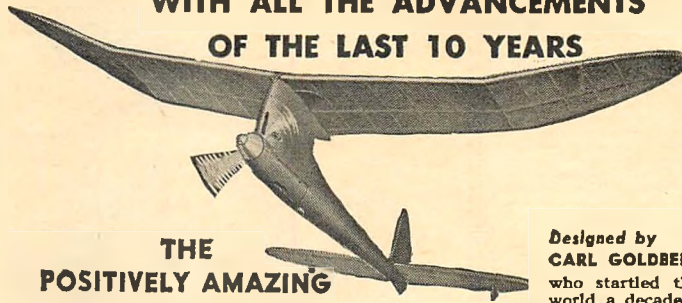

## THE POSITIVELY AMAZING CUMULUS You Asked For it, Free-Flyers, and You Control Liners, Too!

Designed by **CARL GOLDBERG**, who started the gas model world a decade ago with the famous Zipper.

Yes, the gas model world is again excited . . . the word's around . . . the CUMULUS is the ship that can really zip! It's truly modern design, all the way from its streamlined power-packed nose to its de-thermalizer tail that brings her down when you want her down!

The CUMULUS is really today's ship with every advancement which has been developed in the last ten years. Feature upon feature in wing design, fuselage design, and tail design.

The kit is "Precision Pre-finished" in the best American Hobby tradition . . . and includes our "Plans that Really Explain."

**SPECIFICATIONS:** Span 54", length 35". Weight less engine 16 oz. Wing area 3 sq. ft. For engines from .19 to .36. Complete less liquids, Kit G-6, only. **\$4.95**



## NEW RED RACER

FOR TINY ENGINES OR JET TUBES

One kit makes any one of 4 models. New thrills, speed and fun. Race in competition, in circles or straightaway, indoors or outdoors. All parts "Precision Pre-finished", complete less liquids, only. **\$1.00**

## THESE CONTROL-LINERS ARE TOPS IN THEIR FIELD



**GLO-BUG**  
WINGSPAN 27½", LENGTH 21¼"  
DESIGNED FOR .19 to .36 ENGINES  
"PRECISION PREFINISHED" NO-CARVING KIT  
A really hot stunt ship and the simplest to put together. Build it tonight . . . fly it tomorrow! The most fun you ever had building and the most fun you ever had flying!  
KIT G-4. **\$2.95**



**NEW NIFTY!**  
MAKES NIFTY LOOPS!  
WINGSPAN 23½", LENGTH 20"  
DESIGNED FOR .19 to .49 ENGINES  
"PRECISION PREFINISHED" NO-CARVING KIT  
What a kit! Assembles in a jiffy because everything in it is "precision finished." A Winner for contests and a honey for sport flying.  
KIT G-3. **\$4.95**

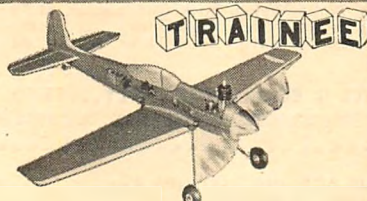

**TRAINEE**  
WINGSPAN 30", LENGTH 26"  
DESIGNED FOR .23 to .49 ENGINES  
"PRECISION PREFINISHED" NO-CARVING KIT  
Smartest looking profile job out today! Actually flies itself with elevator control disconnected! Practically leaps together! No connecting at all! Great for beginners.  
KIT G-2. **\$3.95**



**ZING!**  
WINGSPAN 23½", LENGTH 22"  
DESIGNED FOR .19 to .49 ENGINES  
"PRECISION PREFINISHED" NO-CARVING KIT  
A real speed job for contest and sport flying and a real speed job for building . . . a cinch to build and a circus to fly!  
KIT G-1. **\$4.95**

**American Hobby SPECIALTIES, INC.**  
2635-45 SO. WABASH AVE., CHICAGO 16, ILL.



# LEARN HOW..

TO BUILD FASTER TO BUILD BETTER

## FAMOUS HARBOROUGH SERIES OF AEROMODELING BOOKS

Here are the finest books of their type available today. The thoroughness with which each subject is approached, the complete investigation and the final presentation gives the reader a complete picture of the activity in question. You'll find that it is a lot easier to build winning models when you have these reference books in your aeromodeling library. A few cents spent here will more than repay you in better models.

SOLID SCALE MODEL AIRCRAFT	\$1.25
SIMPLE AERODYNAMICS	.75
Practical Design	.50
Petrol Engines for Model Aircraft	.75
McGilleuddy's Yearbook	.85
Design of Wakefield Models	.50
Design and const. of Flying Model Aircraft	2.00
Camouflage of '14 - '18 Aircraft	1.00
Airscrews for the Aeromodeler	.50
ABC of Model Aircraft Construction	1.25
Airfoil Sections	.50
Camouflage of Aircraft 1939 - 1942	2.00
Indoor Flying Models	1.25
Model Aircraft Petrol Engines	.75
Model Diesels	2.25
Model Gliders	1.25
Nomographs	.50

### MODEL AIRCRAFT PLAN BOOK

20 plans — 20 famous designers — 50,000 words. There are free flight gas models, control lines, all kinds of rubber jobs, gliders and indoor models. All plans are 1/4 full size. Data on diesel engines, radio control, indoor models. Complete instructions for building and flying every model. \$1.00



Now! Complete

**HOBBY LIBRARY CATALOG**  
only 10c



**MODEL CRAFT HOBBIES**

DEPT. MA-1-50  
314 Fifth Avenue, N.Y. 1, N.Y.  
at 32nd St. Open 9:30-6:30 (Thur. 'til 9)  
DEALERS INQUIRIES INVITED

# JETEX 50



ONLY \$1.95

Outfit includes Fuel, Wicks, Mounting Clip — accessories and full instructions. The smallest of the JETEX motors, this is the ideal unit to start in power modeling. It is simple, safe, and cheap to run. Very inexpensive. Easily fitted to models of all kinds, and will fly a plane 12" to 20" span. Specifications: Thrust 1/2 oz., Overall Length 1 1/2", Duration 15 secs., Dia. 1 1/16", Wt., 2 oz., Wt. of Pellet 2 oz.

JETEX OUTFIT advantages — nothing to wear, simple to operate, easy to install, nothing to break, instant starting, clean in use.

### NEW LOW PRICES



No. 100 will fly 18" to 30" model plane. Specifications—Thrust 1 oz., Duration 20 secs., Wt. .6 oz., Length 2 1/4", O. D. 1", Fuel Wt. .3 oz. Complete outfit \$4.50



No. 200 similar to above, larger, twice as powerful, takes 1 or 2 charges at one time, power for 1/2 min. Specifications—Thrust 2 oz., Duration 20 to 30 secs., Wt. 1.1 oz., Length 2 3/8", O. D. 1-5/32", Fuel Wt. .35 oz. Complete outfit \$5.95



No. 350 for serious modeller, for competition. Takes 1, 2 or 3 charges, 12 to 36 secs. duration, 4 oz. thrust, Wt. 2 1/2 oz., Length 3 3/8", O. D. 1 1/8", Fuel Wt. .4 oz. Complete outfit \$8.95



Fuel-Refills—10 charges with spare starter, igniterwicks. For Nos. 50—65e, 100—75e, 200—95e, 350—\$1.00.

## Radio Control for All

(Continued from page 13)

- District No. 4—Old Town Bank Building, Baltimore, Md., Plaza 2662.
- District No. 5—New Post Office Building, Norfolk, Va., Norfolk 24963.
- District No. 6—Federal Annex, Atlanta, Ga., Walnut 3396. Sub-office, Post Office Building, Savannah, Ga., Savannah 7602.
- District No. 7—Federal Building, Miami, Fla., Miami 9-5431. Sub-office, Post Office Building, Tampa, Fla., Tampa M-1773.
- District No. 8—Audubon Building, New Orleans, La., Canal 1739. Sub-office, U.S. Courthouse & Customhouse, Mobile, Ala., Mobile 2-3341.
- District No. 9—U.S. Appraisers Building, Houston, Texas, Woodcrest 61906. Sub-office, Post Office Building, Beaumont, Texas, Beaumont 4010.
- District No. 10—U.S. Terminal Annex Building, Dallas, Texas, Central 5943.
- District No. 11—Post Office & Courthouse Building, Los Angeles, Cal., Madison 7411. Sub-office, U.S. Customhouse, San Diego, Cal., Franklin 9-4101.
- District No. 12—Customhouse, San Francisco, Cal., Yukon 6-4141.
- District No. 13—Central Building, Portland, Oregon, Beacon 0931.
- District No. 14—Federal Office Building, Seattle, Wash., Seneca 3100.
- District No. 15—Customhouse, Denver, Colo., Keystone 4151.
- District No. 16—Uptown Post Office & Federal Courts Building, St. Paul, Minn., Cedar 8033.
- District No. 17—U.S. Courthouse, Kansas City, Mo., Victor 3755.
- District No. 18—U.S. Courthouse, Chicago, Ill., Harrison 4700.
- District No. 19—New Federal Building, Detroit, Mich., Cherry 9330.
- District No. 20—U.S. Post Office, Buffalo, N.Y., Washington 1744.
- District No. 21—Stangenwald Building, Honolulu, Hawaii, Honolulu 56879.
- District No. 22—Federal Building, San Juan, Puerto Rico, San Juan 2-4562.
- District No. 23—Shattuck Building, Juneau, Alaska, Juneau 721. Sub-office, U.S. Post Office & Courthouse, Anchorage, Alaska, Main 535.

Regarding the statement about approved equipment, the law states that the transmitter used on the Citizens Band must be approved by the FCC. If a manufacturer intends to put such a unit on the market, he has to submit a sample to FCC, and this sample must pass the rigid engineering tests needed to conform to specifications outlined in Item 10. The rules also state that FCC will not go to the trouble of approving a transmitter unless at least one hundred (100) are to be built. This rules out homemade equipment. After such approval has been granted and FCC is convinced that this manufacturer can reproduce other units to these exacting requirements, they may then be offered for sale to any citizen of the United States and a license to operate this transmitter may be obtained by simply filling out Form 505 (no examination needed).

Item 5 briefly outlines the steps necessary to build and operate your own equipment. As will be seen later in describing the equipment, illustrated in Fig. 1, the

# Amazing XMAS Offer of These 7 OUTSTANDING MODEL AIRPLANE BOOKS!

Every modeler needs an "Air Age Library" book—it is one of the most valuable tools in the workshop. Thousands sold all over the world. . . . Give him an "Air Age Library" book for Christmas!

### For BEGINNER and ADVANCED Modelers

- 1—"MODEL AIRPLANE DESIGN" \$3.75  
Complete instructions on Model Flying & Basic Trainer for Aviation, by C. H. Grant, 528 pgs., 205 Diagrams & Plans. Beautifully bound in cloth & gold stamped, 4th ptz.
- 2—"MODEL MOTOR MANUAL" \$3  
Gives complete coverage of every phase of model motor operation; also helpful tables, drawings, photos of gas, jet & diesels.
- 3—"AIR AGE GAS MODELS" \$2  
Collection of 21 gas powered model planes designed by America's champion modelers. Plans & instructions. Also hints for beginner & expert gas model builder.
- 4—"FLYING SCALE MODELS" \$1.50  
Complete detailed plans & step-by-step instructions for building 16 flying scale military planes designed by Stahl, Struck & Weiss. Also "Plane Tips."
- 5—"SCALE MODELS BY WYLAM—BOOK 1" \$1.50  
William Wylam is recognized as world's foremost model draftsman. His first volume includes Masterplans of 21 famous U. S. & Foreign planes; also 3 engines.
- 6—"SCALE MODELS BY WYLAM—BOOK 2" \$1.50  
Masterplans of Avro Lancaster, Bell Alcomet, B-17G, B-29, B-24H, PB-5A, A-26, C-25, P-40, Fokker G-1, P-6B, Lycoming engine, A-22, B-26D, Mitsubishi QB-01, P-51B, A-17A, P-61, P-47D, S.E.-5, SB2U-1, Air Bombs, & Wright Bros. Original Flier.
- 7—"SCALE MODELS BY WYLAM—BOOK 3" \$2  
Masterplans of: Albatross D-1 to D-6, P-63A, C-97, Bristol FB, DeH. 4, A-26, C-25, Hispano engines, Lewis machine guns, XP-67, Piper PA-8, SE-5 colors & squadron markings, Siemens engine, Siemens-Schukert D-4, Spad 7, 11A-2, & 13 C.I., XP-54, & Vickers machine guns.

• FREE Postage to any Address in the World.

## 3 Xmas Combinations

- A** No. 1 Model Airplane Design.....\$3.75  
No. 2 Model Motor Manual..... 3.00

Value \$6.75

**BOTH BOOKS FOR ONLY...\$5.00**

- B** No. 3 Air Age Gas Models.....\$2.00  
No. 4 Flying Scale Models..... 1.50

Value \$3.50

**BOTH BOOKS FOR ONLY...\$2.00**

- C** No. 5 Wylam Book One.....\$1.50  
No. 6 Wylam Book Two..... 1.50  
No. 7 Wylam Book Three..... 2.00

Value \$5.00

**ALL 3 BOOKS FOR ONLY...\$3.50**

AIR AGE, INC., 551 Fifth Ave., New York 17, N. Y.

I enclose \$..... for which please send immediately the following books from your AIR AGE LIBRARY:

(Note: Put circle around Combination letter, or Book numbers)

Combination Offer	A	B	C
Books Nos.	1 2 3 4	5 6 7	

Name .....

Address .....

City..... Dist. No..... State.....

# THREE FLASHY BEAUTIES YOU CAN MAKE

## IN ABSOLUTE SCALE ✓ ✓



**DOUGLAS C-124 GLOBEMASTER**  
**\$2.00** Heavy-duty, all purpose transport. Perfect reproduction of this aerial giant of the USAF.

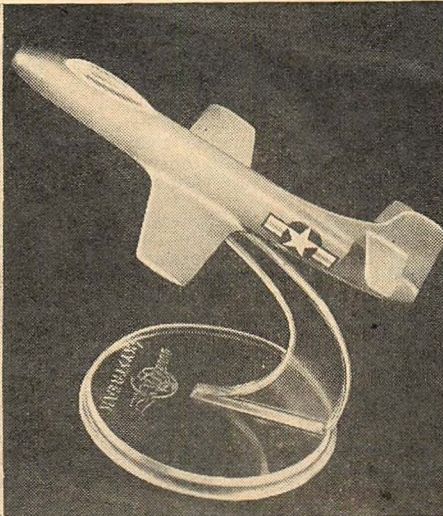

**DOUGLAS D-558 SKYSTREAK**  
**\$1.00** This is the radically advanced airplane that captured two world's speed records in 5 days.



**DOUGLAS D-558-2 SKYROCKET**  
**\$1.50** Revolutionary research craft designed and developed for U.S. Navy at Douglas' El Segundo Plant.

YOU ARE LOOKING AT THE RESULTS OF AN EXCEPTIONALLY HEAVY INVESTMENT IN DIES ALONE! Just to give you precise models of some of the most exciting aircraft in the world today. With a few minutes of simple assembly work, you have a finished model, built to Douglas specifications—perfect as to detail and

color. These all-plastic beauties turn into proud displays of workmanship—collector's pieces. Kits furnished complete with all components and accurate insignia. Fully illustrated instructions and actual performance spec sheets on the real-life aircraft are supplied.

✓ ✓ By the makers of the "Klover Klub Line"

EVERY NEIGHBORHOOD DEALER SHOULD STOCK THIS FASCINATING SERIES OF PERFECT SCALE REPRODUCTIONS.

**ALLYN SALES CO.**  
 6425 McKinley Avenue Los Angeles 1, Calif.

technical difficulties to be encountered will be outside the abilities of most model builders. Anyone so qualified could probably easily obtain a "Ham" license and operate their control systems on the 6-meter band as has been done for the last decade or more.

Items 6, 7, and 8 are entirely self-explanatory and need no further comment.

Item 9 states one of the definite limitations on the use of the Citizens Band transmitter that had to be taken into consideration in the design of the equipment, which will again be discussed later in the description of the transmitter and receiver. It is interesting to note, however, that the FCC in writing the law concerning equipment for the Citizens Band, had the interest of the Radio Control of Model Aircraft very much in mind, as it is mentioned several times in the rules and regulations, and is therefore one of the uses for which the Citizens Band is intended.

Item 10 lists the strict requirements of frequency stabilities and limitations of power to be used which may be passed over by the model builder who is not technically informed in the radio art. To those who are, it is evident that they are very rigid and explains the reason why FCC approval must be obtained on all equipment used, so that it does not get off frequency and cause interference with other existing services.

Added to the above, the frequency of 465 mc. is above the frequency at which conventional tubes will operate. It was necessary to go to a subminiature tube (6K4) without a base and the single tube is soldered in place. The necessity of soldering the tube in place solved one problem of conforming to FCC regulation—changing a tube would throw the unit off frequency.

Fig. 1 shows a representative transmitter completely assembled. The batteries are self contained and the complete unit weighs four (4) pounds. When controlling a plane in flight, it is held in the hands and the antenna, shown on top of the transmitter box, is pointed in the general direction

of the plane. The top rod is the antenna and the one near the box, the reflector (A system widely used in television antennas). These rods are half wave antennae for 465 mc., approximately a foot long. Compare this with the eight (8) foot dipole that has to be erected on the 6-meter band.

The receiver shown on the right is also a single tube job and between it and the transmitter in Fig. 2 are the batteries needed to operate it in the plane; one A-battery equivalent to four pen cells which will last better than an hour, and two 30-volt hearing aid B-batteries which will give over five hundred (500) hours of useful life.

The receiver weighs five (5) ounces and the batteries together another five (5) ounces, giving a total weight of ten (10) ounces. Even small ships with .099 engines will lift this.

The transmitter sends out a single frequency, unmodulated signal when the operating button is depressed. The receiver converts this high frequency radio signal into a change of plate current sufficient to operate a sensitive relay. The no signal receiver plate current is approximately 0.2 ma., and this rises to between 1.0 and 1.2 ma. when signal is sent to it from the transmitter.

The system using an unmodulated carrier was selected for several reasons, (1) because it has been used for ten or fifteen years and has been well proven as to reliability, (2) it is the simplest system using only one tube, (3) because Item 9 in the Rules and Regulations states "stations used for radio control must not radiate energy continuously." If a modulation system were used, it would be desirable to leave the carrier on all the time, but this is prohibited by law.

The antenna is built into the receiver. It is a square aluminum band shown in Fig. 1 at the bottom of the receiver. Since it is tuned at the time the receiver is adjusted for frequency it eliminates the necessity of supplying an antenna in the model and

## E-Z-JUST HOT-ROCK

The Plastic Control Handle Designed for

### S-P-E-E-D

**85¢**



Finger-tip adjustment, (no screws, bolts or tools needed!) sure-lock, — and easily felt and seen "up" position. Save many seconds in speed flying. Hot fuel resistant plastic. 330 lb. pull-test-cable leaders hold the world's hottest models.

### E-Z-JUST REGULAR PLASTIC CONTROL HANDLE

All the features of the Hot Rock in a larger handle. Tailored to your hand grip..... **85¢**

### E-Z-JUST TEST AND BREAK-IN STAND

Locks up any engine in a few seconds, and keeps it from pulling



out while "revving up". Hardwood frame, adjustable frame, adjustable clamps and locking pins..... **\$1.25**

At Leading Dealers Everywhere  
**MANUFACTURED BY PHIL-LEYS BUFFALO, N. Y.**



## For Quality & Service

### BALSA WOOD Best Quality—36" lengths

STRIPS			SHEETS		
1/16 sq.	1/2	3/16x5/8	6c	1/64x2	8c
1/16x1/8	1c	1/4 sq.	3 1/2c	1/32x2	8c
1/16x3/16	1 1/2	1/4x3/8	4c	1/20x2	8c
1/16x1/4	2c	1/4x5/8	7c	1/16x2	8c
1/16x3/8	2 1/2	1/4x3/4	8c	3/32x2	10c
1/16x1/2	3c	5/16 sq.	5c	1/8x2	10c
3/32 sq.	1c	3/8 sq.	6c	5/32x2	12c
3/32x3/16	2c	3/8x1/2	6c	3/16x2	14c
3/32x1/4	2 1/2	1/2 sq.	9c	1/4x2	16c
3/32x3/8	3c	3/4 sq.	15c	5/16x2	18c
3/32x1/2	3 1/2			3/8x2	20c
1/8 sq. 3 for 5c		<b>PLANKS</b>	\$ .55	1/2x2	22c
1/8x1/4	2 1/2	1x3	1.10	1/32x3	13c
1/8x3/8	3c	1 1/2	1.80	1/16x3	13c
1/8x1/2	4c	2x2	2.25	3/32x3	16c
5/32 sq.	1 1/2	2x6	1.80	1/8x3	16c
3/16 sq.	2c	3x3	1.50	3/16x3	22c
3/16x1/4	3c	3x6	3.00	1/4x3	25c
3/16x3/8	3 1/2	4x4	3.50	3/8x3	31c
3/16x1/2	5c	4x6	4.25	1/2x3	34c

### Beveled balsa trailing edges, 36" lengths

3/32x3/8	3c	5/32x5/8	5c	7/32x3/8	7c
1/8x1/2	4c	3/16x3/4	6c	1/4x1	8c

### Propeller Blocks

8x7/8x1-3/16	6c	1-3/4	24c	18x1-3/4x2	32c
10x1x1-1/2	10c	9x1-1/2x2	15c	Glider Wing	
12x1x1-1/2	12c	10x2x2-1/4	25c	Section	
14x1-3/16	18c	16x1-1/2x2	26c	3x3/16x20	18c

Comet tube cement	10c & 25c
Testor A or B cement	10c & 25c
Clear Dope	1 oz. 10c, 2 oz. 20c, 8 oz. 50c
Thinner	1 oz. 10c, 2 oz. 20c, 8 oz. 50c
Colored Dope	1 oz. 10c, 2 oz. 20c, 8 oz. 65c
Red, Orange, Yellow, Green, Lt. Blue, Metallic Red, Metallic Blue, Black, White, Silver, Olive, Drab	
Music wire	3 ft. .020 & .030, 3c; .035 & .040, 4c;
Silkspan, White	.00, 5c sheet; GM, 10c; 3 for 25c
Jap Tissue, Red, Yellow, Blue	2 for 15c
GM Tissue, White, Red, Yellow, Blue	10c; 3 for 25c
T-56 rubber, per ft.	
1/32, 1/16, 3/32, 1/8, 1/4, 3/16, 1/2c; 1/4, 2c	
Aluminum tubing, per ft.	
1/16, 3/32, 1/8, 1/4, 3/16, 1/2c; 1/4, 18c	
Brass tubing, per ft.	
1/16, 1/8, 3/32, 1/4, 1/2, 3/16, 1/8, 3/16, 1/4, 24c	
Plywood sheets	
1/16x12, 1/16, 3/32, 1/8, 3/16, 1/4, 30c	
Cellulose acetate sheets .005, .010, .020, .030	
Testor curved balsa propellers	
1 1/2", 1 3/4" & 1 7/8" dia.	50c ea.
Jasco rubber tube	1 oz. 15c
Jasco Microfilm Solution	1 oz. 17c
Prop hook	small 5c; med. 5c; large 5c
Large face bushings	3/8", 7/8", eyelet 1/10x3/16, 5c
Propeller hinges	20c set
Tensioner springs	5c
Ball bearing washer .040" I.D.; 1/16" I.D.	10c
Prop washers 1/8" OD; 1/4" OD	24 for 25c

Free postage in U.S.A. Foreign orders add 15%

### FOUR STAR MODEL BUILDERS SUPPLY

116 State Street Schenectady 5, N.Y.

## Man's Gift of the Year!

# 'FORTY-NINER'

Complete set of X-acto Hobby Knives and Tools in portable wooden chest \$25.

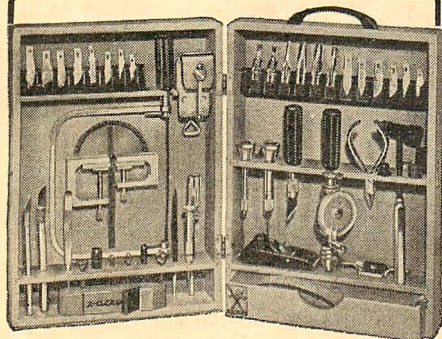

Every knife, tool and blade in the famous X-acto line... 49 in all! Precision made, easy to handle, joy of amateur and expert hobbycrafters in every field. Other "big buys" in X-acto chests are: No. 82 X-acto Knife Chest (for beginners) \$3.50. No. 86 X-acto Hobby Chest (modelbuilders' delight) \$10. No. 87 X-acto Tool Chest (desk drawer workshop) \$15.

# X-acto

## KNIVES & TOOLS



\*Reg. U. S. Pat. Off.

X-acto Crescent Products Co., Inc.  
440 Fourth Ave., New York 16, N.Y.

in turn avoids the need for any critical antenna adjustment.

The purpose of this article is to inform those model builders who would like to fly R.C. models, but who have been deterred by law by the necessity of obtaining an amateur license, what sort of equipment will be made available to them for legal operation on the Citizens Band. The brief description given above of progress to date on this equipment proves that it can be done with no sacrifice of weight or distance of control and it seems that it will be simpler to use and operate than present 6-meter equipment. The only limitation is that the average man cannot legally build it himself.

For those model builders who have never considered R.C. due to the license requirement, but might be interested as a result of this article, it is suggested that they look back through their back issues of MODEL AIRPLANE NEWS and read some of the excellent articles that have been written on control systems. It will be found that all radio control starts with a transmitter, and a receiver which is capable of closing a pair of contacts on a relay contained in the airplane. The closing of these contacts are then made to operate auxiliary apparatus in conjunction with an additional source of power, such as a small battery. The best known is a simple escapement that controls the rudder.

In Fig. 2 we see the assembled plane with the transmitter beside it. The plane has a six-foot wing spread and the control system is a *Rudevator* mounted on the stabilizer.

Fig. 3 shows the receiver and its associated wiring mounted in the fuselage of a plane, with the transmitter standing beside it.

(Editor's Note—The Citizens Band equipment illustrated and described in this article has already been checked by the FCC and slight changes suggested by the Commission are now underway. Watch the columns of this magazine for notice of final FCC approval on all equipment suitable for radio control operation on the Citizens Band.)

## Air Ways

(Continued from page 31)

Bob says the ship has a fast, flat glide and lands like a feather. The ship is unusual in that the fuselage is constructed of formed plexiglass, while the wings are the usual planked construction. Bob is very much interested in scale models of ships in the period from 1925 to 1938 and would like to hear from any individuals who have good plans or prints of such airplanes which he may copy and work up into models.

Our second illustration shows a tiny CO2 powered free flier built by Charles Thure (64 Rowena Road, Newton Centre, Massachusetts). This is a miniature *Powerhouse* scaled down from larger CO2 plans to fit the *Campus A-100* engine and is exactly half the size of the plane designed for use with O. K. CO2 power. Construction is mostly of 1/32" sheet. The size reduction brought the span down to 16 1/2", with an area of 37 1/2 sq. in.

An old-timer appears in picture No. 3. Our veteran modelers will recall the Boeing Mailplane, and this control-line version was built by Dusty Carter (9533 San Miguel, South Gate, California). Dusty sent a long letter together with his photo and it appears that he is defending the scale model builders. Personally, we don't think they need any defending, since the trend even among the contest control-line fliers is to more realism, as we can judge from the great interest in team flying, semi-scale racers, and scale control-line contests. To get back to the picture, the plans were drawn from an old issue of M. A. N. and the ship, which was designated Douglas M-2, came out to a scale of 1/2" to the 1". It is built entirely of 1/32" sheet. Wings have no spars and the model is finished with two coats of sanding sealer and three coats of colored dope. It weighs 6 oz. complete and ready to fly and is powered with an O. K. *Cub* engine and a *Spitfire* propeller. Performance is very good—the ship has an amazingly

short take-off run and with a terrific rate of climb.

Julio G. Dumo (Goodyear Tire and Rubber Company of the Philippines, Ltd., Fifteenth and Atlanta Streets, Port Area, Manila, Philippine Islands) is shown in picture No. 4 about to launch his original Wakefield design, which has a single blade folding propeller. The wing has a sheeted leading edge, and although the ship had only been entered in one contest when the photograph was taken, it proved to be a very satisfactory flier.

It is apparent that David W. Jones (300 Palos Road, Glencoe, Illinois) who sent us No. 5 goes in for unusual experimental models. This particular job, which is what is generally termed the "flutterwing" type, proved to be a very fine flier but has some rather unusual flight characteristics as compared with the more usual type of control-line. The ship was actually made by a friend who never flew it, and when Mr. Jones obtained it from his friend and made a few slight alterations, he felt that it was worth while to give it extensive flight tryouts. Equipped with a *Bantam* engine and 10-6 prop, the ship took off with great ease but just chugged along at about 20 mph. It was found necessary to hold the horizontal stabilizer at about a *minus* 10° angle in order to keep the model from climbing too steeply. He has found other rotor plane types somewhat similar in flight characteristics. The large diameter prop was used in this case as it seemed wise to cover as much of the rotor with slipstream as possible.

A jet speedster from the Canal Zone appears in No. 6. This was built by Cpl. Don Mattingly (319 Fighter Sq., France Field, Canal Zone). At France Field he was engaged in a great deal of model jet flying. At the time this picture was made, the speed job had been flown at about 119 mph. The large nose on the plane carries a big can used as a fuel tank; as Don says, "It requires lots of filling."

The unusual flying float plant in photo No. 7 was built by Thaj Frolund (Ahlgade 21, Holback, Denmark). He designed this ship with the idea of going after the float plane record. The model has a 42" span and is made throughout of Abachi wood, since balsa is rather scarce in his country. Power is supplied by a very smooth running Danish *Mikro-Diesel* engine.

Photograph 8 depicts a Wakefield model in the act of take-off. The ship was built and flown by A. B. Abell (62 Zanti Street, Maryborough, Queensland, Australia) and was entered in the Queensland Annuals last summer. Mr. Abell was crowded out of first place by the small matter of 6-2/5 secs. Readers will realize that this is a modified Korda Wakefield design, the main modification being to build the fuselage to more than an airfoil section than was the original. The plane is powered by 28 strands of 1/8" flat, black English rubber.

K. G. Miller (Eight Hust View Road, South Croydon, Surrey, England) sent us our ninth snapshot, showing a lightweight duration model designed by R. Parham and built by Mr. Miller. The original ship of this type was a winner at the British National Contests in 1947.

A hot stunt job appears in picture 10. "The Sliver," which was so named because of the fuselage construction, was built by Marty Lihl (25 66th Street, West New York, New Jersey) who feels that it is an ideal stunt job. Span is 30" and the stunter is powered with an *Arden .19* glow plug engine. The landing gear is removable and the whole ship, including landing gear, weighs 15 oz.

Another lover of unusual designs is Blaine R. Parker (2050 Emperor Avenue, Apartment 54, Temple City, California) who dreamed up the tricky job appearing in No. 11. Although it is not too obvious, this tailless ship has a swept-forward wing and it is, of course, a free flight job. Wingspan is 40" and power an *Arden .099*. The general proportions for the ship were taken from an article on swept forward models which appeared in a past issue of M. A. N.

Our last photograph shows a neat sport model which although it is a low winger, (Turn to page 40)

# Everybody's Choice

FOR THEMSELVES...OR AS A GIFT



## Torp Jr.

LOADED WITH DYNAMITE  
THE STANDOUT OF THE INFANT TYPE CLASS

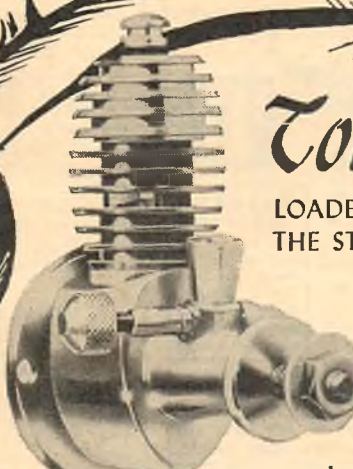

**\$550** COMPLETE WITH GLO PLUG AND FUEL TANK

Here's the most versatile engine on the market today. Adaptable to all types of flying and modeling, this baby will give you more fun than any other engine... and what's more, if you're a contest enthusiast, watch the prizes start rolling in with the Torp Jr. Put it through its

paces, see the power, the climb, the speed...and remember, the Torp Jr. has the horsepower output equal to larger size engines in the Infant type class.

Your dealer has the Torp Jr. in stock now...and in time for Christmas too...See him today.

## Infant WORLD FAMOUS .020 MORE IN DEMAND THAN EVER

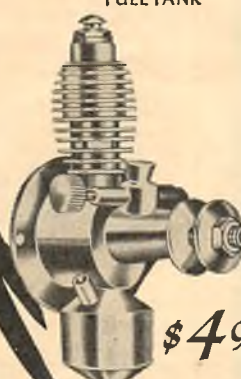

**\$495**

COMPLETE WITH GLO PLUG AND FUEL TANK

Modelers all over the world have made the Infant, world's smallest production made glo ignition engine, a must in their model engine collection. This masterpiece of engineering and design has answered the call for a small engine. You should have one. Fully guaranteed by K & B, recognized as the symbol of quality in the model engine field.

To all of our many modeler friends all over the world, may we extend a very Merry Christmas and a Happy New Year and also say thanks for your patronage the past year.

Lud **K & B** Rodney  
Johnny Rodbeck

**K & B MFG. CO.**  
6901 S. Eastern Ave.  
Bell Gardens, Calif.

All jobber or dealer inquiries from outside continental United States or Hawaii, please contact Bob Irving, Exporter, 3365 Barham Blvd., Hollywood 28, California

## NEW SENSATIONAL OFFER

1. NEW PHANTOM ERA KIT
2. NEW OHLSSON '23' OR '19'
3. NEW ACCESSORIES KIT  
\$25 Value for only \$12

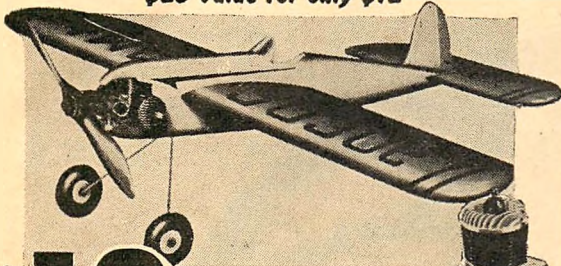

**\$12**  
P.P.

CHOICE OF  
OHLSSON '23'-'19'  
McCOY '19'  
BANTAM '19'

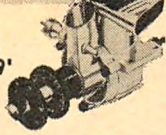

**OUT OF BOX—INTO AIR**  
Completely prefabricated profile stunt model with the famous "Hollow-Structured" Wander Wing. CONTENTS • Assembly sheets • rubber wheels • land gear • hardware • metal fittings • motor mounts •

**NOT A KIT . . . BUT A READY-TO-RUN MOTOR**  
Combination offer includes the newest and finest deluxe O & R '23' engine that has just been Rollerized . . . Rollerized . . . Rollerized . . . for your 1950 varied model flying.

**DELUXE • PHANTOM ERA KIT \$14**  
**OUTFIT Choice OER 29 or McCOY 29**

**COMBO CONTAINS OVER 100 ITEMS** • Phantom Era • motor • metal stunt tank • bellcrank • horn • hinges • cement • fuel • book on engine repairs • nuts • bolts • washers • brush • solder • pliers • battery leads • push rod wire • gas funnel • plastic gas line • propeller • swivels • Glo-Plug • gasket • screw driver • control handle • 100' control wire • motor test block • formed land gear • all metal knife • rubber wheels • leather tool case • sandpaper • plans for automatic takeoff helper • steel scale • speed indicator • 25 insignias • masking tape • instructions on control flying • motor test chart • club membership • gas line • catalog, etc., etc.

## CLOSE OUT! LIMITED QUANTITY GLO-MITE



**5.95**  
P.P.

**A READY-TO-RUN MOTOR**  
GUARANTEED. Formerly sold for \$14.50. Supply limited. NOTE: We stock all parts for the "MITE". Write for parts list.

**SPECIFICATIONS**  
CLASS A • WT. 2.7 oz. • OPP DISP. 9,000 RPM • .5 INS BORE & STROKE

## STILL AVAILABLE! NEW ERA COMBO



**\$12**  
P.P.

Includes New Era and complete accessories kit listed in Phantom Era offer and choice

**DELUXE • NEW ERA**  
**OUTFIT ACCESSORIES KIT**

choice of  
O & R '29' \$15  
McCOY '29'

We stock every item advertised in News. Just send us your order with remittance in full . . . or \$1 and we'll ship C.O.D. for balance.

**MERCURY MODEL AIRPLANE CO.**

920-N1 UTICA AVE.  
BROOKLYN 3, N. Y.

SEND 3c FOR CATALOG  
and FREE "Motor Mints"

## THE BEST ENGINE YOU CAN BUY

**DYNA-JET**  
PAT. PENDING

**The SUPER ENGINE**

**SPEED!** 179.03 mph official AMA World Record! Guaranteed to develop over 4 1/4 lb. Static Thrust, the equivalent of more than 2 Hp. exerted at 125 mph with 70% propeller efficiency! **COMPACT!** Maximum diameter is only 2 1/2", overall length 2 1/2", and weighs only 16 ounces! **SPORT!** The easiest starting and most reliable engine ever built. No propellers to break. No ignition system to burden your model . . . no fuel to mix . . . runs best on plain gasoline without oil! **GUARANTEED!** 1. To start easily with hand tire pump. 2. To equal or exceed advertised power. 3. Against defective material or workmanship. **\$35.00:** At your dealers. If he can't supply, order direct. Immediate delivery! **MODEL AIRPLANE KITS!** For Dyna-Jet, by leading mfgs., at your dealers. Not sold by Aeromarine Co.

**AEROMARINE COMPANY**  
Dayton Municipal Apt., Vandalia, Ohio

## THE DYNA-JET

**RED HEAD**

**FAMOUS JET  
MINIATURE  
GASOLINE ENGINE**

**POPULARITY PROVED!**  
THE HIT OF THE  
1948 CONTESTS

The more people SEE Dyna-Jet in action the more people BUY Dyna-Jet. Two years on the market and today more popular than ever. The center of attraction wherever it is used!

**OFFICIALLY ACCEPTED!**  
**AMA RECORD  
179.03 M.P.H.**

Officially accepted by AMA for all contests and as holder of the world speed record. Accepted by Airplane Kit builders. Owner acceptance . . . Just ask the man who owns one!

**WORLD'S MOST ECONOMICAL!**  
WILL NOT WEAR OUT

No propellers to break . . . no bearings or pistons to wear out! Constant high re-sale value! Savings can more than make up the difference in cost between Dyna-Jet and cheaper engines in only one season's flying! Your most economical buy!

it is a very nice flier. The builder, Eduard Breland (Station WAML, Laurel, Mississippi) writes that it is the first low wing free flight model to be constructed in Laurel and has caused a great deal of interest among other modelers. The ship is fairly fast in the glide but is extremely rugged and makes very realistic take-offs and landings.

## NEWS OF MODELERS

**PEN-PAL SEEKERS:** W. Powell, 228 Scraftoft Lane, Leicester, England, is 17 and is mainly interested in free flight power and control line flying. He would like to correspond with a pen pal about his own age. . . Charles W. Peach, 12 Beckenham Grove, Shortlands, Kent, England, enjoys radio control flying best and also would like to write to a model enthusiast . . . L. G. van Lien, Mathenesserdijk 19b, Rotterdam (w.), Holland, is eager to talk about model flying with someone about his own age, 17.

**SPECIAL REQUESTS:** G. D. G. Weale, One Cowgate Road, Greenford, Middlesex, England, wants to swap current editions of MODEL AIRPLANE NEWS for current editions of the British magazine AEROMODELLER. Furthermore, anyone who could send any spare copies of M. A. N. (from March, 1940, to December, 1949), would make his Christmas complete . . . Rene Charette, 213 Besserer Street, Ottawa, Ontario, Canada, has a collection of 1,000 sketches of aircraft designs and inventions, most of which, he is certain are patentable. Mr. Charette wants to dispose of this collection and wonders if M. A. N. readers would be interested in having them—FREE, of course!

## CLUB NEWS

### California

A new U-Control club—**Hell Divers**—has been organized in Fresno. Don Frietas, 4035 Mono, Fresno, is seeing that the club doesn't get off on the wrong foot until the election of officers takes place. We understand that this new outfit has been putting on quite a show at the Hornet Hobby Park. At the club's last meeting, they decided to apply for membership in the *Western Associated Modelers*.

Following are the results of the *Fresno Gas Model Airplane Club's* monthly Free Flight Meet. Class A—Jim Scheidt 3:16.6; Class B—John and Anna Cassela 14:58.2; Class C—Fred Mosier 9:59.2; Class D—Al Weymouth 10:00; *Jrs.*—Gerald Oldershaw 13:46.4; Class A—T. Diel 621 pts.; Class B—M. Martin 690; Class C—J. Tiftick 605; Class D—F. Ginder 726; and *Jrs.*—F. Morgan 590.

Newly elected officers of the *Northrop Institute Model Mechanics Club* are Don Newberger, president; George Fleming, vice president; and Irving Wong, secretary-treasurer.

### Maine

The *Propsnappers Club* recently held elections. Earl Barker is president; Don MacFarland, vice president; Fay Venner, secretary; Malcolm Kennedy, treasurer; and Francis Maguire, corresponding secretary.

### New Hampshire

A very active group is the recently formed *Bristol Bats*, of Bristol, N.H. A regular flying session is held every Sunday in Nathan Morrison's large field (he not only gave them permission to fly but he even keeps the grass mowed!). So far the club has not entered any competition, but recently put on an air show in conjunction with Community Center Days, attended by several hundred persons. Stunts included three-plane flights, speed flights, pattern flying, and novelty flying, parachute dropping, streamer chopping, and wheel rolling. Considering that in several cases the planes being flown were first attempts by the builders and that most of them had less than three months' experience, the boys feel they are doing fairly well—and we think so too! AMA membership is to be applied for after the first of the year, and this spring the club hopes to enter active competition. One hundred per cent member

activity has been attained by the requirement that prospective memberships be applied for after the applicant has built his own plane. (A good way to get workers.) This eliminates anybody who doesn't mean business as there is plenty of help available. The club president is Robert Higgins, secretary, Rodney Mooney, and club advisor is Roy L. Clough, Jr. Interested parties in the Bristol vicinity are urged to get in touch with the club.

#### New York

The third Long Island Invitational Championships sponsored by the *Screamin' Demons* was an outstanding success. Over 200 contestants from a radius of 125 miles were in attendance. The winners are: *Class A*—E. Frankenfeld 810 secs.; *Class 1/2A-CO2*—A. Schumacher 473 secs.; *Class B*—Joe Eder 688 secs.; *Class C-D*—W. Grant 858 secs.; *Rubber*—Irv Wolk 907 secs.; *Towline*—Tom Devile 764 secs.; *Hand-Launch Glider*—Jerry Stoloff 142 secs.; *PAA-Load*—Class A Sr.—Jerry Stoloff; and *Class B Sr.*—Walt Herr. Thanks to Fred J. Otten, corresponding secretary, for the results. Fred also calls our attention to the new Club address: 14 Frazer Street, Hempstead, N. Y.

#### Ohio

The *Rubber City Aeronauts* had so much business to attend to at their last meeting at the YMCA (25 members attended) that Nick Hauprich, Arrangements Committee Chairman, postponed showing the 1,000' of film from the National Air Races until the December meeting.

#### Oregon

Even though it is a little late for the results of the Free Flight Meet held August 28, 1949, by the *Medford Prop Nuts*, they requested them in print anyway. *Class A Jr.-Sr.*—D. Liechty (3-flight total in secs.) 758.0; *Class B Jr.-Sr.*—J. Bowman 1131.9; *Class C Jr.-Sr.*—J. Feuz 823.7; *Class D Jr.-Sr.*—J. Feuz 189.9; *Class A Open*—B. Kern 1284.0; *Class B Open*—R. Edwards 286.5; *Class C Open*—E. Otto 1238.0; *Class D Open*—R. Edwards 530.1; *Class 1/2A Open*—L. Crowell 1287.0; *Class 1/2A Jr.-Sr.*—D. Simonson 681.2; *Rubber Cabin Class CD*—C. Otto 340.7; *Rubber Stick Class CD*—F. Young; *First Official Flight*—D. Simonson; *First Official Flight of 10 min.*—L. Crowell; *First with 3 Official Flights*—R. White; *Best Finished Model Flight*—M. Roberson; *High Points for Entire Meet*—R. Edwards 295.

We received the results of the *Portland Fire Balls U-Control Contest* held September 25, 1949. *Class A Speed Sr.*—Mel Doernbush 99 mph; *Jr.*—Ray Arrigotti 78; *Class B Speed Sr.*—Gerald Thomas 110; *Jr.*—Wayne Jensen 97; *Class C Speed Sr.*—Dick Morris 114; *Jr.*—Jack Hudspeth 111; *Class D Speed Sr.*—Gerald Thomas 136; *Jr.*—Jack Hudspeth 117; *Stunt Sr.*—Don Roberts 407 pts.; *Jr.*—Don Nelson 429; *Scale Sr.*—R. D. Smith 108 pts.; *Jr.*—Ray Arrigotti 95; *U-Control Flight Plan Sr.*—Don Roberts 187 pts.; *Jr.*—Wayne Jensen 181. Raymond Arrigotti, member of the publicity committee, writes, "An interesting event of the Meet was the first U-Control Flight Plan event of the West Coast, a competition devised by Jim Walker. To qualify, the contestant may fly either a sport or stunt plane. He files a flight plan, specifying number of laps to be flown and number of seconds model will remain in the air. One hundred points are gained for flying exact number of laps, one hundred points for flying exact time, and twenty-five points for perfect spot landing. Points are deducted for missing the predicted laps, time, and spot. The flying time of the model may be controlled only by the amount of gas. Since stunts and high speeds afford no advantage, the Novice stands an equal chance against the Expert."

#### West Virginia

Here are the results of the Free Flight Contest sponsored by the *Kanawha Valley Model Builders, Inc.*, on September 25, 1949, near Charleston. *CO2*—R. H. Frasher, Jr. 170.5 secs.; *Class 1/2A Gas*—Bob Daley 768 secs.; *Towline Sr.*—Walter Blake 405 secs.; *Jr.*—Don Mairs 376 secs.; *Rubber Sr.*—R. H. Frasher, Jr. 750 secs.; *Gas Sr.*—Bob Mock 127 secs.

# SWEEPING THE FIELD!!

ANOTHER GREAT

## FUEL OF THE CHAMPIONS

FROM THE WORLD'S FIRST, LARGEST, BEST EQUIPPED RACING FUEL LABORATORIES

### INFANT THIMBLE GLOW

For Contest Performance With Arden, Cub, Infant, McCoy and Spitfire Engines

Now you can get stable, smooth, trouble-free operation every time with .02 to .29 displacement engines where close piston and cylinder clearance may develop seizure problems.

To give you this perfect performance, Infant Thimble Glow contains these 16 physical components, blended to exacting proportions: 2 nitrates, 2 alcohols, 6 chemicals, 3 inhibiting solvents, 2 ingredients for counteracting throat irritation from exhaust fumes, Power Mist de-gummed castor oil. Special penetrating and cooling

Get the facts that eliminate guesswork in fuel selection. Ask your dealer or write direct for free copies of "Fuel Facts" and "Humidity Guide."

DEALERS: ... NOW GET OVERNIGHT DELIVERY FROM 42 STRATEGICALLY-LOCATED DISTRIBUTION POINTS

FRANCISCO LABORATORIES

3787 GRIFFITH VIEW DRIVE LOS ANGELES 26, CALIFORNIA

#### READY-BUILT SOLID SCALE MODELS

Precision constructed models in authentic color schemes and finished in top-grade lacquers. These models are completely built in every detail and include controls in outline form, scale propellers and wheels. NC numbers, airline markings and insignias are also included where required.

Constructed from excellent hard balsa stock, these ready-built models have smooth contours and fillets. A minimum of four (4) coats of filler and primer are applied before the final finished lacquers are given.

These custom-built models are tops for personal or business gifts, and they can't be beat for collector's items.

23" Douglas DC-3 or Super DC-3	\$ 50.00
24" Douglas DC-4 or DC-6	60.00
35" Boeing Stratocruiser	125.00
16" Boeing Stratocruiser	50.00
13" Lockheed P-38 "Lightning"	30.00
18" Lockheed Constellation	40.00
18" Northrop P-61 "Black Widow"	50.00
17" North American B-25	40.00
16" Grumman "Mallard"	35.00
16" Grumman F6F "Hellcat"	30.00
13" Grumman F7F-2 "Tigercat"	30.00

CHRISTIE BATLAS & CO.

P. O. Box 2053-MN Pittsburgh 30, Pa.

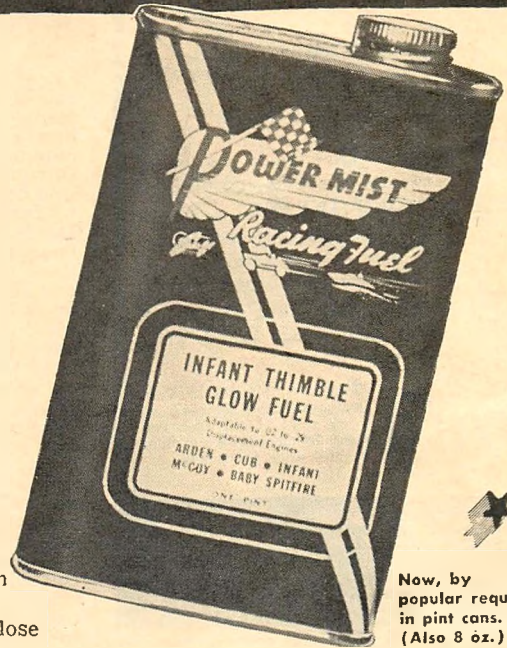

Now, by popular request, in pint cans. (Also 8 oz.)

agents give long operation endurance.

Like other Francisco fuels, Infant Thimble Glow actually develops greater power through aging, when stored in a cool place in air tight containers.

Your dealer now has Infant Thimble Glow in the new, popular pint size cans. Get some today for perfect performance with your pee wee engines.

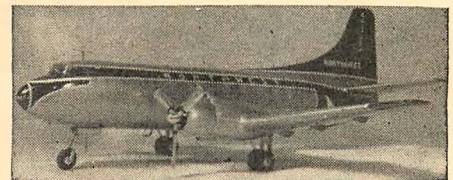

28" Martin 2-0-2 Transport finished model as shown above with red, white and blue Northwest Airline markings..... \$75.00  
 15" Fokker D-7, Fokker D-8 or Fokker Triplane..... \$30.00  
 14" Spad or Nieuport 17 or Nieuport 28..... 30.00  
 24" 1918 Handley-Page Bomber or German Gotha Bomber..... 75.00  
 18" Breguet or D.H. 4 or L.V.G. 2-seater..... 40.00  
 15" Curtiss P-6E or P11C-2 or P-26A..... 30.00  
 14" Pfalz D-3 or Pfalz D-12..... 30.00  
 14" Sopwith Camel or Albatross D-3..... 30.00  
 12" 1940 Vultee Attack-Bomber..... 30.00  
 (On all orders please specify color scheme and markings desired.)

Allow at least 15 days for shipment on special jobs. All orders sent insured, shipping charges collect. No C.O.D. orders. Remit by check or money order. Any type model made on request—send 3c stamp for reply. Minimum orders acceptable \$30.00.

Meet the GLOW PLUG that...

LICKED  
20,000  
TESTS



COSTS ONLY  
**49c**

It took 20,000 block tests to come up with this amazing new "O.K." Glow Plug. And 20,000 tests can't be wrong! The new "O.K." Glow Plug is tops — BETTER 3 WAYS!

On all new O.K. Cubs.

- 1 **MOREGUTS** — stands up under continuous operating conditions.
- 2 **BETTER SPEED RANGE** — high grade glow element makes engine start fast — accelerate easily — operate over wide range of speeds.
- 3 **LONGER LIFE** — has endurance found only in high priced, platinum glow plugs.



\*Two types. SHORT for Cub, Bantam and other engines using 1/4-32 short. LONG for Hot Head, Mohawk Chief and other engines using 1/4-32 long.

HERKIMER TOOL & MODEL WORKS, INC.  
1403 Harter St., Herkimer, N. Y.

Canada: Herkimer "O.K." Engine Co., 311 Hermant Bldg., Toronto. Export: 120 Wall St., New York 3. All cables: Concordia, N. Y.

## REMEMBER RUDEVATOR

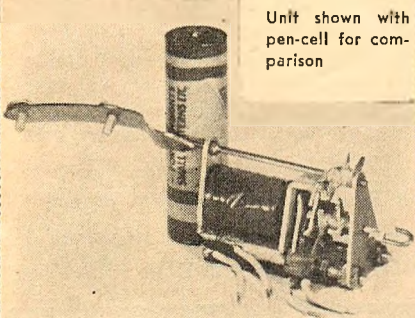

Unit shown with pen-cell for comparison

When you finally get tired of flying that radio job with rudder alone, Rudevator offers greater possibilities because it gives—

**RUDDER & ELEVATOR WITH SIMPLICITY, RELIABILITY, LONG LIFE AND PLENTY OF ADJUSTMENT.**

Remember also—  
**POWER CONTROL**

With the control tank fuel system described in this issue. This is our latest development that combines with Rudevator to bring complete power control to the glow plug engine, with the addition of only one electric check valve which we shall furnish on order.

Remember THIS TOO!—

Our development program is finished. Our contributions to the art are Rudevator and glow plug Power Control. We feel satisfied that no other combination of parts will give as much control for so little weight and complexity, for many years to come. From now on it is up to radio reliability and flight practice!

RUDEVATOR ..... \$12.50  
CHECK VALVE.....\$ 5.00

Money Order, C. O. D. accepted, or write for information

## RUDEVATOR

BOX 536

RESEDA, CALIF.

## Power Control

(Continued from page 27)

beveled and polished to give a seat of minimum area and the tube is slanted to align with the valve. (3.) Check valve. This is a very short piece of fuel line hose and is stretched tightly over part four. (4.) Armature—.020" to .040" sheet iron or steel. Bend as shown so that part three allows the armature to come close but not touch the core of the magnet. Watch the 3/16" dimension of part four. It is a guess and depends on the size fuel line used so as to give a tight fit. (5.) Valve chamber bottom—1/32" to 1/16" brass. File slot and hole as shown in detail to fit coil core and pole piece. A good fit is not necessary since solder will fill the cracks upon assembly. (6.) Coil—wind almost full with No. 30 enameled copper wire. Scrambled turns are all right since the resistance will come out close enough anyway. The coil can be wound in many ways but the technique described here and shown in Fig. 2 assumes that a minimum of tools are available. Here's how. Obtain a two- or three-inch length of 3/16" iron or steel rod for part fourteen. It might be found in a large bolt or wood screw. Don't let anyone talk you into buying a fancy piece of special magnet iron because there just isn't enough to be gained in this case. File out two washers (part thirteen) from .040" or .062" micarta or fibre. Drill a small hole as shown near the center hole in one of them. The center hole should fit close to the iron rod. Push these two washers on the iron. Now solder a fine copper wire a little more than the thickness of part five from one end and another wire about 3/4" away from it. These wires will serve to hold the washers on the rod when the coil is wound. Spread the washers on the rod and glue a thin layer of paper on the rod between washers. Set a hand drill in a vise, chuck the iron rod in the hand drill and wind the coil. Start by threading the coil wire through the small hole that was drilled in one of the washers. This lead is now out of the way and is later soldered to the iron pole piece for ground. A good cover for the coil that is not effected by glow plug fuels has not yet been found so just take a hitch in the last turn to hold it down—fuel will not effect the enamel on the wire. Saw off the iron rod about 1/8" from the coil. (7.) Pole piece—.040" to .062" sheet iron or steel. (8.) Mount bolt—No. 3-48 or No. 4-40 machine screw tapped or jam fitted and well soldered into part seven. Use the screw head while fitting and then saw the head off. (9.) Armature leaf spring—.005" spring brass or bronze—1/2" wide. (10.) Valve chamber cover—1/32" brass 5/8" wide. (11.) Valve chamber side plates—1/32" brass. (12.) Thru bolts—No. 3-48.

Start assembly by soldering coil six in the hole of part seven. Mount and solder part five and then file the coil core and pole piece almost flush with part five. Solder part nine to part four and then solder to part five. Top off with parts one, two, and ten. Test valve by sucking on tube two before closing chamber with end plates eleven, nuts, bolts, washers, and gaskets. Valve should travel about 1/16" and the armature should not touch the pole. The valve should just operate at 1-1/2 volts so as to be safe on three volts. File or sand edges of chamber flat before sealing closed. (It is hoped that this valve may be made available commercially or we may consider furnishing it on request.)

Fig. 3 shows how the control tank low level limit switch can be mounted. Switch arm is .005" spring brass and a fibre washer is added to the piston rod for insulation. Point the contact screw for good contact thru any castor oil that may be present and make the spring action as light as possible.

Fig. 4A shows one method of mounting the inlet and outlet tube on the control tank and Fig. 4B shows an alternate method. Take your choice. Either the Austin Timerette or the Baby Timer can be used. The larger one of course gives more push for a given fuel pressure. In Fig. 4A, the tube is soldered to a strap of 1/32" brass and mounted over a small hole in the tank with a 1/32" rubber gasket. The tank should be mounted in the airplane with the

brass tube on top, not at the bottom as shown in Fig. 1.

If a large Austin timer is used for the main tank, the same holds true and the rework is identical to figures 4A or 4B. The rubber hose at the other end of the tank can be added along with a gasket under the tank end cover to provide a drain overboard in case the slight fuel seepage past the leather piston becomes objectionable. In the main tank, the original spring is used but in the control tank a new spring is made about as shown in Fig. 4C. Ten to fifteen turns of .020" music wire are wound close and then pulled to the size shown.

Fig. 4D shows the simple flow control clamp that goes on the hose between the check valve and the control tank. Squeeze with pliers at S to reduce the rate of flow and hence the rate at which the engine accelerates.

Fig. 4E shows the approximate size of Fashstock clip to buy for use as a shut-off valve on the fuel system filler hose. A little bending with pliers may be required to get it working right.

Fig. 4F shows how the engine shut-off clamp is made that goes on the hose between the control tank and the engine. 1/32" brass is used as usual but all dimensions can be varied to suit. Fig. 4F shows the valve open; squeeze at C to close. Fig. 4G shows the valve closed; squeeze at O to open. This little gadget is a great help in the ground handling of the engine.

Fig. 5 shows throttle details for an O & R engine. This plug type valve eliminates the necessity of drilling holes in the engine and it requires the least accuracy of workmanship to get a satisfactory fit. The principle of this valve can be applied to almost any engine by changing the details to suit. Of the three views, some parts are omitted for clarity. The dress snap on the glow plug is just an incidental idea thrown in for the record. The wire is run to a booster battery plug and simply saves a few more of the clumsy motions necessary when starting the engine. The throttle linkage shown is about as simple as can be made. Spring brass wire (.0040") is used, and in the side view an adjustable cam action is obtained by bending the wire.

The plug must fit well in the intake of the engine to be sufficiently airtight because any air leakage will make it impossible to get a really low rpm. This plug can be made by pushing a wood dowel into the main bearing of the engine and filling the intake with melted solder, but a preferred method is to carefully shape a rubber or neoprene plug that gives a cork fit in the intake. The needle valve serves to hold it in. Get an Austin Universal needle valve, as the Ohlsson valve has no seat and doesn't shut off well. Look for plug material in the rubber eraser line or tear a hunk off a truck tire while the driver isn't looking. The rubber must be soft enough to seal well but hard enough to mount the throttle valve bracket which is made of 1/32" brass. Saw the plug off about 3/16" below the center of the needle valve hole. Don't try to drill the final sized holes in the rubber but start small and finish with a rat tail file; 1/8" to 3/16" is plenty of diameter for the air intake hole. The plug valve is made from 1/4" brass rod. Hold the rod in a hand drill and put the hand drill in a vise. Drill a small hole in the rod and then taper with a file while turning the hand drill. Saw off the finished plug and solder in a length of .010 music wire. Getting a nice swivel connection between this wire and the valve rocker arm is a small but fussy job, so take your time. Use your head on the rest of the details; this article is getting too long!

A very satisfactory main fuel tank comes already made in the form of a rubber bulb. Ask a druggist for an infant size rectal syringe. Don't be surprised if he gives you a queer look. Just explain that it's for a radio controlled airplane; this will probably cause him to close the store and go home early. In fact, rub it in by buying two syringes. One is used for the main tank and the other is used as a filler bulb. The one for the tank is lashed down to a plywood floor or bulkhead with enough rubber bands to give the required pressure.

(Turn to page 44)

# NEW!

**.099 CUB**  
in the A Class  
"OK" in Every Way

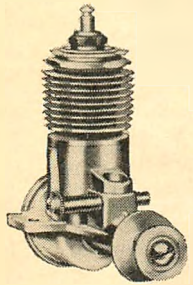

only  
**5.95**

Incl. famous  
"OK" Glow Plug

You'll go for this rugged, high output engine in every way. Easy to start—chock full of power—with the best power weight ratio (1 7/8 oz.). Lug mounting, interchangeable with Cub .049 and .074.

Develop up to 15,000 RPM!

**.049-074 CUB**

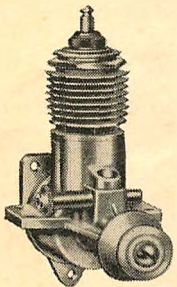

only  
**5.95**

Incl. famous  
"OK" Glow Plug

Take your choice of power application. For indoor flying, free flight and sports flying—the .049 Cub is tops. For free flight, sports flying, stunting and speed flying—you can't do better than the .074 Cub. Low wind resistance thanks to small frontal area. No installation limitations, either—use either radial or lug mounting.

Unique patented port design provides radial fuel injection—higher turbulence—more effective scavenging—to give you higher power on weight ratio basis.



## The *Only* Complete MINIATURE ENGINE LINE

An Engine for Every Class  
A Model for Every Purse

# NEW!

The Improved 1950 Models are Here! Now at your dealer's—the new advanced Hot Head, Super 29 and Super 60. Re-designed with ebonized cylinders and gold anodized cylinder heads. Smoother performance! Higher output!

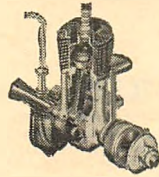

### Class A "O.K." BANTAM

—an improved 1950 model of the record smashing engine, designed by Ben Shereshaw, noted model engine designer. Wt. 3 1/4 oz. RPM 2,500 to 11,600. Complete with spark plug and tank for only

**\$11.95**

### Class A "O.K." BANTAM

—**GLow PLUG MODEL.** Features all the championship performance and construction details that won world-wide fame for its brother spark plug model. Complete with plug, less tank.....

**\$9.95**

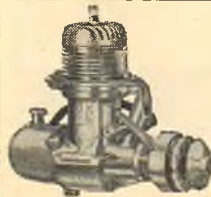

### Class B "O.K." SUPER 29

—with high-compression head, rotary valve and ram induction. Complete with spark plug and tank, an outstanding bargain at only.....

**\$11.95**

### Class B "O.K." HOT HEAD

—extra rugged for the extra stresses of pre-ignition firing. Will exceed spark ignition speed when "O.K." Hot Head Fuel is used. Wt. 7 oz. Complete with plug, less tank, only

**\$9.95**



### Class D "O.K." SUPER 60

—aluminum crankcase for lightness. Large size ball-bearing and new domed cylinder head for smooth performance. With 3-position timer located at rear for easy access. Complete with spark plug and tank.....

**\$11.95**

### Class D "O.K." SUPER 60—

—**GLow PLUG MODEL.** With steel cylinder, hardened crankshaft and hardened and lapped piston for long wear. Complete with plug, less tank. You can't beat this value at only...**\$9.95**



### "O.K." TWIN

—an experimental engine for large models and radio-controlled ships. Wt. with tank 23 ozs. RPM 1,000-6,000. Complete, less coil.....

**\$49.00**

### "OK" COILS



—fast spark, low battery drain. Models for A to D Class engines. Complete with lead**\$1.50**

Famous Twin Coil with leads and matched condenser—for all makes of two cylinder engines—now at new, amazingly low price. Only....**\$3.50**



### "O.K." CO 2

—the basic trainer in the compressed gas class. No gasoline, battery, timer, coil or spark needed. Wt. bare 3/4 oz. RPM 3,000-7,000. Complete, ready to run.....

**\$4.95**

### New "OK" GLOW PLUG

It took 20,000 block tests to come up with this sensational glow plug. And it proved itself better three ways—more guts—better speed range—longer life. Two types—short or long—each only.....**49c**



Engines and complete parts service at your dealer's. See him today, or write for catalog to:

# HERKIMER

## TOOL and MODEL WORKS, Inc.

201 Harter St., Herkimer, N. Y.

CANADA: Herkimer "O.K." Engine Co., 511 Hermant Bldg., Toronto  
EXPORT: 120 Wall St., New York 5, N.Y. (All cables: Concordia, N.Y.)



# Everybody is talking!

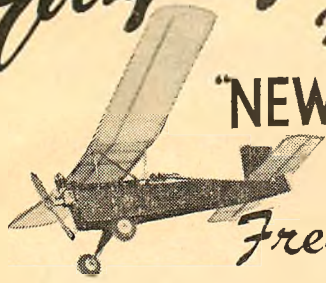

It's the  
**"NEW DEAL"**  
in  
Free Flight  
**"SKIPPY"**

A super flying free flight model with provisions for FREE FLIGHT STUNT!

— FEATURES —

- ★ All Parts Pre-Cut
- ★ Excellent Flying
- ★ Simple Construction
- ★ Scale Appearance

THE KIT IS A MODELER'S DREAM COME TRUE! ALL BALSA PARTS ARE PRE-CUT, INCLUDING FUSELAGE SIDES, WING RIBS, FORMERS, WING AND STABILIZER TIPS, AND OTHERS... FORMED WIRE PARTS, RUBBER WHEELS, "SKY-SAIL" COVERING AND MANY OTHER FEATURES TO BE FOUND IN P.B.C. KITS. CONSTRUCTION IS SIMPLE AND RUGGED, PROVIDING THE MODELER WITH A PLANE CAPABLE OF MANY, MANY BEAUTIFUL FLIGHTS OF LONG DURATION — PLUS — STUNT FLYING!!!

A kit for "baby" motors \$1.95

AT YOUR HOBBY SHOP

**P. & C. Model Mfg. Co.**  
Campbell, Ohio



### GREMLIN

20" WINGSPAN — FOR O.K. CUB, BABY SPITFIRE AND OTHER SMALL BORE MOTORS. ALL PARTS ARE PRE-CUT. SOLID BALSA WING IS READY TO USE — A PERFECT AIRFOIL ELIMINATES UNNECESSARY AND BOTHERSOME SANDING. CAN BE ASSEMBLED EASILY AND QUICKLY BY THE BEGINNER. \$1.00

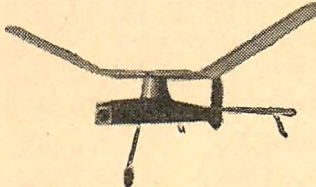

### COOKIE

24" HIGH PERFORMANCE RUBBER POWERED MODEL THAT WILL THRILL THE NOVICE AND THE EXPERT WITH ITS SENSATIONAL FLYING ABILITY. KIT CONTAINS SEMI-FINISHED CONTEST PROP, PLENTY OF CONTEST RUBBER, READY CUT FUSELAGE SIDES PLUS PRINTED SHEETS, TISSUE, WIRE, ETC. CONSTRUCTION IS VERY SIMPLE. 75c

DEALERS: CONTACT YOUR LOCAL JOBBER  
DISTRIBUTORS: WRITE US NOW

## WATCH FOR ANNOUNCEMENT OF THE REVOLUTIONARY CITIZEN-SHIP RADIO CONTROL

TRANSMITTER AND RECEIVER  
OPERATES ON THE CITIZENS BAND

465 MEGACYCLES

NO "HAM" LICENSE REQUIRED

INQUIRIES INVITED

**VERNON C. MACNABB Co.**

NATIONAL DISTRIBUTORS

915 WESTFIELD BLVD.

INDIANAPOLIS 20, INDIANA

# here is a NEW World War I

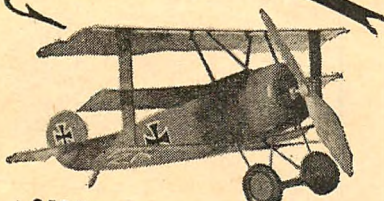

GERMAN  
**FOKKER DR-1** \$1.00 AT YOUR DEALER  
TRIPLANE

SPAN 11 1/2"  
AT YOUR DEALER

**WESTERN DEALERS NOTE:**  
For Quick Service Order Direct From  
**DOUGLAS MODEL DISTRIBUTORS**  
193 EAST SECOND SOUTH SALT LAKE CITY, UTAH

### 1/2 INCH SCALE FLYING MODELS

DESIGNED FOR CAMPUS CO2  
OR RUBBER POWER

*Featuring—*

RUGGED—ALL BALSA CONSTRUCTION  
EASY TO FOLLOW INSTRUCTIONS. FULL SIZE PLANS  
COMPLETE PRINTED SHEET BALSA PARTS  
TEST PROVEN DESIGN FULL COLOR DECALS  
A FLYING MODEL WITH THAT SOLID SCALE LOOK

OTHERS AVAILABLE IN THIS SERIES

BRITISH SES-A	SPAN 13 5/16"	\$1.00
BRITISH CAMEL	SPAN 14"	\$1.00

ASK YOUR DEALER FIRST

If Ordered Direct Please Add 10c Postage

**CARTER CRAFT MODELS**  
16 MONTICELLO ARCADE NORFOLK 10, VIRGINIA

Place a piece of square balsa on top of the tank to keep the rubber bands from sliding off. Push a piece of hose line over the spout of the tank and lead this to a tee that is made from two pieces of 1/8" copper or brass tubing. Mount the tank with the spout up so that all air will escape by the time the engine is started and running well.

The syringe that is used as a filler is much better than a pump can because all air can be removed from it with a gentle squeeze before the fuel is transferred into the main tank. Here's how to fill the filler bulb rapidly from the fuel can. Solder a short length of brass tube into a hole drilled into the fuel can cap. Don't run it to the bottom of the fuel can but stop it short inside the can cap. Put a short hose on the brass tube or on the filler bulb spout. Now, pressurize the fuel can by squeezing the volume of the filler bulb into it. Then turn the fuel can upside down and rest it on the edge of something. The pressure in the fuel can will fill the bulb in a hurry. Before filling the main tank, squeeze the filler bulb until solid fuel runs out. Connect the filler bulb back to the fuel can and let it hang there for storage.

Just a few hints now on how to operate the control tank fuel system. The details are somewhat different from the usual pressureless fuel system. With the main tank full, operate the check valve. Things won't work right at first. For one thing, the fuel system is full of air which must be displaced. Open the shut-off and the needle valve and let the main tank prime the whole system until the control tank is full of fuel and not just air. If the control tank piston is dried out, it may need some pushing and pulling to get it to take hold and seal. Now to start the engine. Close the shut-off, plug in the starter battery and flip the prop over to make sure the engine is dry. When dry, open the shut-off and go on flipping while making the usual needle valve adjustments. When the engine starts, close the check valve switch (if radio control, the Rudevator should be on neutral after down) so that the control tank will fill. Adjust the needle valve for full speed. Now let the control tank run down. If the engine starts to fail, push lightly on the control tank piston rod to determine whether the engine is failing because of too rich or to lean a mixture. If too lean, the control tank spring is not strong enough. Take it out and stretch the spring a little. If too rich, the opposite is true. Clip a turn off the spring. This may be cumbersome work but once the spring is within range it is there to stay. Some adjustment can be had by turning the needle valve fuel hole down if the engine goes rich, or up if lean. Now proceed to clean up all the other details. Time the control tank from full power to idle (or cut-off) and adjust the stroke to suit. Also time it from idle to full power, and adjust the flow control clamp to suit. In fact, you can count on running a whole pint or more of fuel through the engine before things are all ironed out to satisfaction. Some details haven't been mentioned for lack of space but these are minor and will soon become obvious. When finished, you will have the cleverest darn fuel system that was ever invented. (We say this just in case nobody else will.)

### Design Forum

(Continued from page 14)

engines to some extent. From a practical standpoint if you consider that your engine turns at 10,000 rpm you will get very efficient results. So the pitch speed then becomes 10,000 times the actual pitch P.

The difference between the actual pitch P and the theoretical pitch  $P_T$  is called the PROPELLER SLIP. This must be known in most cases in order to determine the actual pitch speed, because when you purchase a propeller, the theoretical pitch is usually marked on the propeller, and not the actual pitch. The actual pitch P is found by subtracting the slip, Fig. 1, from the theoretical pitch  $P_T$ . For practical results a propeller may be considered to have a slip of .16" for every inch of diameter, for maximum operating efficiency. In other words a 10" propeller will have a slip of 1.6". To determine the actual pitch this slip must be subtracted

from the theoretical pitch, indicated on the propeller when you purchase it. For instance, if you purchase a 10" propeller with an 8" pitch its actual pitch at maximum efficiency will be approximately 8 minus 1.6 or 6.4". Now you can determine the most efficient pitch speed of your propeller as follows: multiply 6.4 by 10,000 and divide it by 12 to obtain the pitch speed in feet per minute. As a simple formula, it is: Pitch speed,

$$V_p = \frac{(P_T - .16D) \text{ rpm}}{12} = \frac{6.4 \times 10,000}{12} = 5,333$$

So the pitch speed is 5,333 feet per minute. This is between 60 and 61 mph and under these conditions is the most efficient operating speed for your propeller. If your plane flies more slowly than your operating speed, your propeller blades will be slipping at a greater angle than 3° so that drag will be greater and thrust will be less. The most difficult problem in designing models is adjusting the speed of your airplane to the most efficient propeller pitch speed.

Now let us consider the other end of the stick, the airplane flight speed. Naturally, for contest work it is desirable to have the propeller operating at maximum efficiency during climb. This means that the flight speed during climb must be equal to the actual propeller pitch speed. Then, in the particular case just given, the speed while climbing must be 61 mph for best results. If your plane is not capable of this climbing flight speed but flies at only 50 or 40 mph, then the propeller slip will be excessive during climb and the propeller will be operating inefficiently. In choosing the correct propeller therefore, first determine the actual flight speed of your plane during climb. This does not mean climbing speed which is the vertical distance traveled per minute, but the speed at which the plane passes through the air while climbing. To calculate the precise climbing flight speed for any particular airplane is complicated and involved. Aeronautical engineers may do this but it is our purpose here to give a simple yet fairly accurate method of determining this speed. Instead of determining practical results from theory, we have reversed this process and worked out a theoretical formula from actual flight practise which will give you approximate results for any airplane. For flight speed

$$\text{during climb, } V_p = 83,300 \left( \frac{\sqrt{Cu}}{A} \right)$$

in feet per minute. In the formula Cu = the cu. in. piston displacement of the engine; A = wing area in sq. inches.

Now let us take an actual case and work it through. If you have a .2 cu. in. engine and 288 sq. inches of wing area, then the calculations are as follows:

$$V_p = 83,300 \left( \frac{\sqrt{.2}}{\sqrt{288}} \right) = 83,300 \left( \frac{.585}{16.95} \right) = 83,300 (.03475) = 2,875$$

So, we see that the flying speed while climbing is 2,875 feet per minute, or 32.6 mph. We know now that for an efficient propeller the pitch speed must be the same, i.e., 2,875 feet per minute. To obtain this

pitch speed for any given engine revolution per minute we must select a propeller with the correct theoretical pitch. A simple formula which shows the relation of the factors of flight speed, required theoretical propeller pitch, diameter and engine revolutions per minute is as follows:

$$\text{Required, } P_T = \left( \frac{12 V_p}{\text{rpm}} \right) + (.16D).$$

In the formula  $P_T$  = the theoretical propeller pitch in inches. This is the pitch indicated on the propeller when you purchase it. D = the diameter in inches; rpm = the revolutions of the engine per minute at maximum efficiency;  $V_p$  = flight speed during climb which in turn must equal pitch speed. Now we insert numerical values in this formula as follows: 2,875 is the flight or pitch speed, 10" for diameter and 10,000 revolutions per minute for rpm, and the formula works out this way—

$$P_T = \left[ \frac{12(2,875)}{10,000} \right] + .16(10) = \left( \frac{34,500}{10,000} \right) + 1.6 = 3.45 + 1.6 = 5.05 \text{ inches}$$

So, we see the theoretical pitch should be 5.05". If the engine turns 9,000 revolutions per minute the pitch should be 10/9 of this or 5.62". The theoretical pitch may be found by combining the flight speed and pitch formulas as follows:

$$P_T = \frac{1,000,000}{\text{rpm}} \left( \frac{\sqrt{Cu}}{A} \right) + (.16D).$$

This will give you the required theoretical pitch for any model without the necessity of first determining the flight speed; the latter is included in the formula. This will serve as a starter for determining the most efficient propeller for any plane. Possibly, this will not give you the exact result but by means of a little experimenting with propellers of slightly greater or lesser pitch than that specified by the formula, you can determine the most efficient propeller-airplane combination.

This may help Mr. Gottlieb, of S. Masselin Avenue, Los Angeles, Calif., who says, "I have heard five different people say that five different propellers were the best for a particular airplane and others were no good." With this formula the best propeller can be determined within very close limits. We will be interested in hearing from readers of the results of their application of this formula.

There are other factors in propeller design which have a bearing on results, one which is overlooked by most fans and propeller manufacturers is the required blade area. Most manufactured propeller blades have only about two thirds the area required for most efficient operation. Fig. 2 shows a common propeller blade indicated by the dotted line, the more efficient size is indicated by the heavy line.

Another factor is the propeller shape. Many standard propellers have tips that are fairly well pointed. This is a mistake. It has been found over many years of practise, since 1910 in fact, that rounded tips give superior results. Fig. 2 also shows the more efficient tip outline.

# BABY "Spitfire"

Equipped with Spitfire Glow Plug

## COMPLETE POWER UNIT

precision made dependable easy-starting already to install.

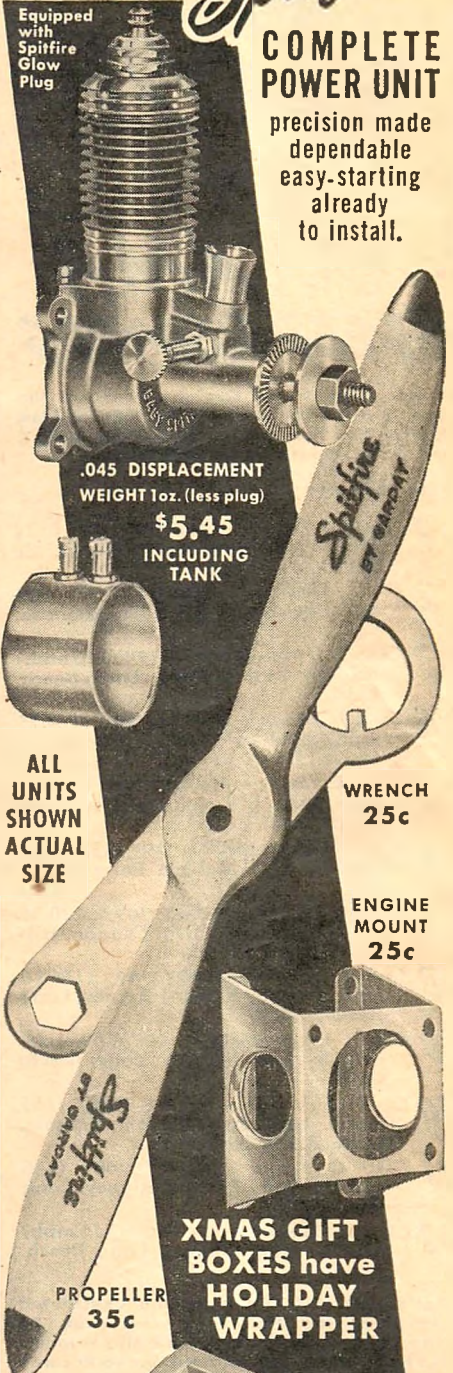

.045 DISPLACEMENT  
WEIGHT 1oz. (less plug)

\$5.45  
INCLUDING TANK

ALL UNITS SHOWN ACTUAL SIZE

WRENCH 25c

ENGINE MOUNT 25c

PROPELLER 35c

XMAS GIFT BOXES have HOLIDAY WRAPPER

NEW BOX LOOK FOR IT

Only

\$5.95

...for Complete Combination

REGULAR ANDERSON QUALITY

MEL ANDERSON Manufacturing Co.

1819 THIRD AVE., LOS ANGELES 6, CALIF.

## ADVANCED MODEL BUILDERS

Only the BEST can be FIRST

The Anderson Spitfire dominates all other model engines in the U-Control and Free Flight Classification, holding all Class D National Free Flight records as certified by the AMA Contest Board.

IF IT'S POWER YOU WANT The Anderson

"Spitfire" IS YOUR BEST BUY

STILL \$24.95

WRITE FOR FREE FOLDER

AT DEALERS EVERYWHERE

.645 Displacement



## "Spitfire" GLOW PLUG

SHOWN DOUBLE SIZE



WITH THE NEW "Spitfire" COMBINATION CONNECTOR

It combines Positive and Negative in a single clip

PLUG only . . . 49c

CONNECTOR . 15c

ANOTHER SPITFIRE

ACHIEVEMENT!!

Fits any engine with standard 3/32" thread

PURE PLATINUM FILAMENT

Brighter Glow



# MCCOY

## Official AMA SPEED RECORDS

To keep the record straight, here are the facts! McCOY Engines hold ALL Official AMA Control Line Speed Records in Class A, B, C and D, in Junior, Senior and Open.

Here they are:

- 1 Class A Junior - McCOY "19" (124 mph) held by Warren Tomme, Little Rock, Ark.
- 2 Class A Senior - McCOY "19" (118 mph) held by Gene Stiles, Alameda, Calif.
- 3 Class A Open - McCOY "19" (126 mph) held by Lew Mahieu, Long Beach, Calif.
- 4 Class B Junior - McCOY "29" (127.75 mph) held by William Mitchener, Peoria, Ill.
- 5 Class B Senior - McCOY "29" (132.26 mph) held by Richard Rigney, Long Beach, Calif.
- 6 Class B Open - McCOY "29" (138 mph) held by Lew Mahieu, Long Beach, Calif.
- 7 Class C Junior - McCOY "49" (120.56 mph) held by William Cannon, Hillton Village, Va.
- 8 Class C Senior - McCOY "49" (136.36 mph) held by Richard Rigney, Long Beach, Calif.
- 9 Class C Open - McCOY "49" (150 mph) held by Lew Mahieu, Long Beach, Calif.
- 10 Class D Junior - McCOY "60" (165 mph) held by Warren Tomme, Little Rock, Ark.
- 11 Class D Senior - McCOY "60" (156 mph) held by Richard Rigney, Long Beach, Calif.
- 12 Class D Open - McCOY "60" (156 mph) held by Lew Mahieu, Long Beach, Calif.

That's why McCOY's were the undisputed winner at the National's, and took 16 "first" places at the New York Mirror meet, and hold MORE Official AMA Speed Records than ALL OTHER MAKES COMBINED.

It takes power to win - McCOY Engines supply MORE POWER than any other engine available today!

Be a Winner - with a REAL McCOY!



## DURO-MATIC PRODUCTS COMPANY

HOLLYWOOD 38, CALIFORNIA

Fig. 3 shows another fault, many propellers have comparatively small angles near the hub. That is, the leading and trailing edges of the blade do not run directly to the center of the hub but are off-set as at R (dotted line). The more efficient blade is shown in heavy lines where the leading and trailing edges have very little if any off-set at the hub.

These facts are not theory, they have been determined from long practise. An incident that occurred at the 1934 National Contest at Akron, Ohio, indicates the wisdom of having very little hub off-set. Joe Kovel was flying his record breaking KG gas model and in attempting to improve propeller efficiency with what he thought was a new and better idea, he carved a propeller with smaller blade angle at the hub as shown by the dotted line, Fig. 3. On his first official flight, to his chagrin, the plane rolled very slowly along the ground when released and finally stopped without taking off. Apparently there was very little, if any, thrust. Upon careful examination of the propeller it was suggested that he change the shape of his propeller by carving away the edges near the hub and increase the blade angle as shown by the heavy line Fig. 3. This was done and another flight attempted. The plane got underway quickly and took off without any trouble with this changed propeller. Actually, what was taking place was that the blade near the hub was passing through the air at a negative angle of attack when the plane was moving forward so that a forward thrust was generated. The blade near the tip of course generated a thrust backward. However, this forward thrust subtracted from the backward thrust left only a small percentage of the backward thrust that was effective for flight; approximately only 50% of the normal forward pull. When the propeller was changed the full normal thrust was developed.

Mr. Gottlieb also has some other questions as follows: "Is downthrust a means of lowering the C.L.A. so planes won't spiral dive or spin when the rate of climb gets too steep?" Yes, downthrust is a means of lowering the C.L.A. because by incorporating downthrust the tail of the airplane is dropped relative to the thrust line and consequently the C.L.A. is lowered also. This lower C.L.A. gives greater stability under a greater variety of flight conditions. It also prevents stalling by pulling the nose downward when the plane is nosed up sharply.

Another question is: "When designing a Class D plane what would be the best wing loading, large wing with large drag, or smaller wing with smaller drag?" We presume here that Mr. Gottlieb means "best for climb." We would choose in this case the large wing rather than the smaller one because this larger wing will give a greater ANGLE of climb. The airplane will fly more slowly with a large wing but the angle and also the rate of climb will be greater. The smaller wing will give greater flying speed but the angle of climb will be less. Of course, the wing can be made so large and the flight reduced in speed to such an extent that the rate of climb might be less. However, even in this case though the rate of climb is less the length of the glide will be very much more, and will thus more than compensate for any reduction in the climb.

Here is another question—"When I adjust the horizontal tail and wing in different horizontal planes, the model rolls out nicely. WHY?" Fig. 4 indicates this condition. A slanting stabilizer, as shown, operates only slightly against the torque tendency of a propeller during normal flight, to hold the tail so it will not swing to the left of the airplane (to the right in diagram) because the stabilizer angle-of-attack is small. When the speed diminishes at the steep point of the climb and when the plane approaches the stalling point, the slanted horizontal stabilizer has a greater tendency to swing to the right against the torque effect (to the left in the diagram) because the stabilizer has a large angle of attack and lifts more at this point of the flight. Consequently, the tail slides to the right, the airplane noses to the left and into a left bank. In other words, it rolls out of the stall.

## METEOR ENGINE

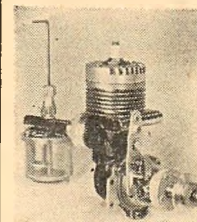

"All Steel"  
Construction  
.23 Displacement  
AUTOMATIC  
VALVE  
INTAKE

Spark Ignition with Plastic gas tank \$15.00  
Glow plug ignition 12.95

Front Plate Motor Mount

Order from

**R. J. HETHERINGTON**

4434 Eagle Rock Blvd.  
Los Angeles 41, Calif.

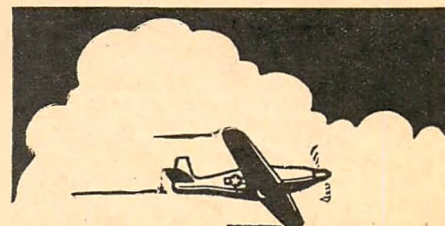

## PITTSBURGH'S WHOLESALE DISTRIBUTOR...

✓ All leading lines

- MODEL AIRPLANES
- MODEL BOATS
- MODEL SUPPLIES
- FULL LINE OF MOTORS

Dealer's Price List Available  
Upon Request

WHOLESALE ONLY

## J. SPOKANE & CO., Inc.

1106 Fifth Avenue, Pittsburgh 19, Penna.

### PHOTO CREDITS

Page		
15	All	Raymond Studios
17	All	Consolidated Vulfee
		Aircraft Corporation
21	All	Gene Patty
23	All	R. C. Hare

## World's First Military Airplane

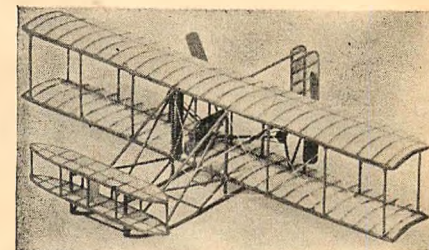

### 1909 U. S. ARMY WRIGHT BIPLANE

This famous, historic model will make an interesting addition to your collection. Prefabricated parts, complete plans & instructions makes assembling easy in 3 to 4 hours. Kit contains plastic fuselage frames, props, 4-cyl. motor, gas tank, struts, etc.

Wing, elevator and rudder frames are ready for covering. 3/16" scale, 8" span.

Packed in attractive display box. Price \$1.00. If not available at your dealers, order direct. Send cash or money order and we will ship immediately postpaid. No C.O.D.'s.

**HILLCREST MFG. CO.**  
1675 CORDOVA ST., LOS ANGELES 7, CAL.

# WAKE CRESCENT YOUR MODEL DEALER IN '50

## ★ CRESCENT RECOMMENDS ★

Ignition Engines		Accessories	
*O&R 29	513.95	U-Reely Control	8.50
*O&R 60	11.95	U-Reely Remote	12.50
*O&R 60 Pak	11.95	*Plastic Control Handle	1.75
*O&R 19 & 23 Deluxe	11.95	*Wood Reel 6" dia.	.50
*O&R 19 & 23 RV	10.95	*Wrench Handle	.50
*McCoy 60	27.50	*2-2 1/2" Stranded wire	2.75
*McCoy 49	25.00	*2-60" Stranded wire	2.95
*McCoy 29	19.50	*2-70" Stranded wire	3.25
*McCoy 19	10.95	*2-3" Leads Ins.	.40
*Super Cyclone 60	12.95	Spark Plugs (all sizes)	.50
*Dooling 61	35.00	"K&B Infant"	.30
*Spittfire 64	29.95	"Baby Spittfire"	.30
*Fox 58	29.95	"Ok Cub"	.50
*Mighty Midget	14.75	1/4 x 32	1.50
*Super Champ 62	14.50	3/8 x 24	1.50
*Triumph 51	15.95	3/8 x 24 Racing	.85
*K&B Torpedo 29	18.50	*Infant Glow Plug	.49
*K&B Torpedo 24	16.50	*Spittfire Glow Plug	.49
Arden .099	9.75	Arden Glow Plug	.85
Arden .199	10.75	Champion Glow Plug	2.75
<b>Glow Plug Engines</b>		*Firecracker Coil	1.95
*O&R 29	12.95	*Competitor Coil	3.00
*O&R 23 Pak	13.95	Aero Ft. Wt. Coil	2.35
*O&R 23 Deluxe	10.95	Aero Quality Coil	3.00
*O&R 19 Deluxe	10.95	Aero Condenser	.30
*O&R 19 & 23 RV	9.95	Metal Condenser	.50
*O&R 23 RV Pak	8.95	*Booster Plug & Socket	.50
*K&B Glo Torp 32	14.95	Toggle Switch	.50
*K&B Glo Torp 29	14.95	Slide Switch	.25
*K&B "Infant" 02	4.95	Negative Tubing	1.20
*K&B Torp Jr. .035	5.50	3/32" O.D.	.20
*Glo Devil 52	12.50	3/16" O.D.	.20
*Triumph 49	12.95	1/4" O.D.	.20
*Triumph 51	12.95	Ignition Wire	.03
*Sportsman Sr. 36	14.95	Silkspan 00	.05
*Sportsman Jr. 36	14.95	Silkspan 01	.10
*Sportsman 29	11.95	Wet Strength Tissue-Red	.10
Arden .099	8.75	Yellow, Blue	.10
Arden .199	9.75	Japan Tissue (White)	.05
*McCoy '9'	7.95	Elmic Timer (Diesel or Ign.)	2.50
*McCoy 19	9.95	D-E Fuel Shut-off	1.00
*McCoy 19 Race Car	10.95	*Austin Timer	1.50
(with pinion gear)	9.95	*Baby Timer	1.00
*Thimble Drome 099	9.95	*Flex Needle Valve	1.00
*Thimble Drome 15	9.95	Universal Needle Valve	.40
*Thimble Drome 199	10.95	Aero Quality Coil	.40
*Baby Spittfire 045	5.45	*Lucite 4-pencil B. Box	.75
O.K. Cub 049	5.95	*Strap Hinges (8)	.12
O.K. .074	5.95	*Bell Crank (Lg. Sm.)	.25
<b>Air Engines</b>		*O&R 60 Metal Fuel Tank	1.75
Campus A-100 w/tank	5.95	*O&R 2 & 19 Fuel Tank	2.00
Campus Bee w/tank	4.95	*Master Stunt Tank (Med.)	1.25
O.K. CO2	4.95	*Maeco Tanks:	1.00
<b>Jetex Engines</b>		Super 1x2x2 1/2"	.75
Jetex 200	8.50	Std. 1x2x2"	.75
Jetex 100	4.95	Sol. 3/4x1 1/4x2"	.75
<b>Control Line Kits</b>		Utility 3/4x1 1/4x2"	.65
*The Chief (C)	5.95	*Baker Wedge Tank	1.25
*Joker (C)	5.45	(Lg. Med. Small)	.35
*Casalaira (C)	8.75	*Baker Tiny Tank (K.D.)	.35
*Madman, Sr. (C)	10.00	*Mart-Lee Mufflers:	1.95
Super-Duper Zlich (C)	4.95	Class A (4")	2.95
Stuntwagon (C)	7.50	Class A & B (5")	2.95
Key (B-C)	4.95	Class C & D (9")	2.95
J. Fireball (B-C)	4.95	Class B-C-D (5 1/2")	2.95
Howard Pete (B-C)	5.95	*I-Blade Prop (B & C)	.35
Monopuce (B-C)	4.95	*"Infant" Power Prop	.35
Mr. Mullinan (B-C)	4.95	*Snap-or-Pack	6.00
Flv. Station Wagon (B-C)	5.50	*O&R 23 Rotary Valve	5.00
Sky Box Trainer (B-C)	4.25	*O&R 6 oz. Flywheel	1.25
Super Sky-Box (B-C)	4.95	*O&R 23 Flywheel	1.50
*Jiggers (B)	3.45	*4-way plug wrench	.50
Lil Duper Zlich (B)	3.95	*Glue Gun	.75
*The "Squaw" (A-B-C)	4.95	*Turbo Fuel Pump	.69
*Brave (B)	3.95	*Hap-The Pilot	.95
*Jester (B)	3.95	*Vest (Wingman) Airwheel	.50
*Curtiss P1A (B)	3.95	2 1/4" \$2.50, 3 1/2" \$3.00, 4 1/2" \$3.50.	
*Warrior (B)	3.95	Semi-pneumatic - 2" 85c, 2 1/2" \$1.00, 3" \$1.50.	
*British SE-5 (B)	4.95	Streamline-1 7/8, 45c, 2 3/4, 60c.	
*Madman, Jr. (B)	4.95	Flying Wheel 1 1/4, 7c, 20c, 1 1/2, 25c, 1 1/2, 25c, 1 1/4, 30c, 1 1/2, 30c, 1 1/2, 35c.	
*Speedwagon 30 (B)	4.95	1/2" English Rubber @ 2 1/2c ft.	
Stuntwagon 30 (B)	4.95	<b>Tools</b>	
Nifty (B)	4.95	Moto-Sander & Polisher	14.85
Zing (B)	4.95	Dremel Moto-Tool #2	23.50
Trance (B)	3.95	Dremel Moto-Tool #1	23.50
Tc 2 Trainer (B)	2.95	Dremel Moto-Saw	5.85
Lockheed Bird (B)	4.95	X-acto Chest #86	10.00
New Era (B)	3.95	*X-acto Chest #77	10.00
Phantom-Era (A-B-C)	2.95	Hobby Hand Drill	1.25
Stuntmaster (A-B-C)	4.95	*Ungar Soldering Kit	2.25
Comet Piper Cub (A-B-C)	2.95	<b>Gas-Powered Boat Kits</b>	
Minnow (A-B)	4.95	Colonial	5.50
Cessna 145 (A)	4.95	Vinyard Sedan Cruiser	5.50
Piper Cub (A-B)	4.95	Harco Cruiser 25"	5.50
Aerona Sedan (A-B)	4.95	Chris Craft 26"	5.50
Beechcraft (A-B)	5.95	Chris Craft Express	5.50
Piper Vagabond (A-B)	3.95	Chris Craft Rambler 27"	5.50
Dynamic (A-B)	3.50	Owens Flagship 26"	5.50
Kingpin (A-B)	4.95	Madman Elec. Drive Unit	4.00
Glo-Bug (A-B)	2.95	Buckeye Speedboat	4.95
Maverick (A-B)	1.00	Eico Cruiser	4.95
Jenners (A-B)	3.95	Eico Drive Unit	4.00
*Invader (A)	5.95	<b>Misc. Boat Kits</b>	
*Fokker-Trip (A)	3.50	Marion Sprague 12"	3.95
Speedwagon 20 (A)	3.95	City of New York 12"	3.95
Super Fury (A)	2.50	City of New York 14"	3.95
Winnie Mae (A)	2.95	Schooner Bluebonnet 22"	3.75
Whirlwind Jr. (A)	2.95	Sov. of Seas 23"	3.75
Super Sultion (A)	2.25	City of New York 12"	3.75
Sweet Pea (A)	2.50	Tug Boat 14 1/2"	3.75
Howard (A)	2.95	Clemont	3.75
Buster (A)	2.50	Clayover Peonon 24"	3.75
Baby Sky Box (A)	3.50	Coast Guard Campbell 22"	4.50
Freshman (A)	2.48	Rev. Cutter Hamilton 22"	4.50
<b>"AA" Control Line Kits</b>		*Eico Tanker 20 1/2"	4.50
Wing Ding	2.00	Constitution 22"	6.00
Puddle Jumper	1.00	US5 Kearsarge 32"	9.00
Infant Wagon	1.75	Flying Cloud	9.00
Baby Era	1.98	Marion Sprague 29"	9.00
Baby TC-2	1.98	Sarcophagus	9.00
Baby TC-3	1.98	Viking	9.00
*Papoose	2.95	PT-10	6.00
<b>Free Flight Kits</b>		Clipper Clock	6.50
Luscombe Sedan (C-D)	7.50	Eico Crusierette 27"	12.00
Playboy Sr. (C)	6.00	O-reen Eliz. w. elec. motor	4.95
Zomer (C)	3.95	Reuhl Racing Yacht	8.95
Cumulus (A-B-C)	4.95	<b>Racers</b>	
Playboy Jr. (B)	3.25	*O&R Racer (Less Engine)	5.95
Zipper (B)	3.95	*McCoy Midget	16.95
Powerhouse (A-B)	4.95	(Complete w/engine)	
Super Brigadier (A-B)	3.95	*Thimble Drome w/engine:	21.50
*Zeek (A-B)	4.95	Lightning Bug 199	25.00
*Miss Tiny (A-B)	3.68	Deluxe Chrome Plated	19.95
Zapper (A)	2.50	Champion 15	23.50
Powerhouse (A)	3.95	Deluxe Chrome Plated	19.95
<b>"AA" Free Flight Kits</b>		*Doodle Bug 099	23.50
*Civvy Boy 24	1.35	*Deluxe Chrome Plated	23.50
*Civvy Boy 31	1.65	PT-D Jr. (w/engine)	14.25
*Small Fry	1.25	*Champion Tether Model	3.95
*Bombino	1.25	*T.D. Geared Drive Unit	3.95
Profile Powerhouse	1.00	*Adapter for Drive 23 1/2"	1.00
Powerhouse "33"	1.50	*Challenger, Jr.	3.95
Cleve. Minnow	1.50		
The Shadow	1.50		

Do your before and after Christmas shopping at Crescent. Send now for Crescent's new catalog (free with order; otherwise 10c) so you'll have it to peruse when that Christmas cash comes in! As modelers all over the world know, we specialize in new and hard-to-get California merchandise. We also carry the best of the offerings from all Eastern manufacturers. Every item guaranteed—fully prepaid if cash with order. You'll find it pays in many ways to do business with the country's fastest growing mail order house! Get started with Crescent in '50 and get real shopping satisfaction!

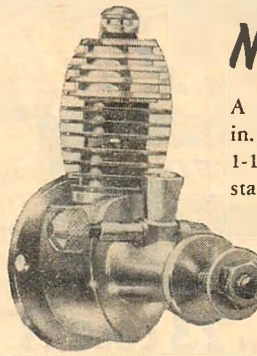

## NEWEST K & B Engine

A little powerhouse. Larger than Infant size. .035 cu. in. displacement. For ALL types of flying. Weighs only 1-1/16 oz. R.P.M. up to 15,000 with a 5" prop. Easy starting. K & B proven performance!

**TORP JR. \$5.50**

For other K & B engines, see columns at left

## Beautiful WARRIOR KITS

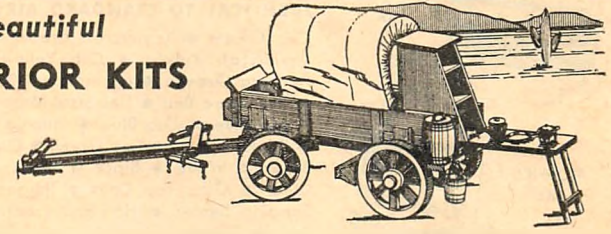

## Death Valley Rancho CHUCK WAGON

### CONSTRUCTION KIT

SHELF MODELERS: Here are the real semi-finished, detailed and complete kits you have been looking for. Wonderful gift box for Xmas giving, with each part in a separate compartment. **\$3.95**

### Santa Fe Trail COVERED WAGON

Companion to beautiful super-detailed CHUCK WAGON. A real fine covered wagon with all accessories, fully assembled wheels, fully formed brake parts, etc. **\$3.95**

## Crescent Christmas Suggestions

For the Gas Model Enthusiast:		For the Boat Modeler:	
<b>Glow Plug Engines:</b>		Reuhl Racing Yacht	\$8.95
K & B Torp Jr. .035	\$ 5.50	Dumas "Colonial"	5.50
OK Cub .074	5.95	Marion Sprague 12"	3.95
Baby Spittfire Xmas pkg.	5.95	City of New York 12"	3.95
McCoy "9"	7.95	Flying Cloud 12"	3.95
O & R 19 DeLuxe	10.95		
<b>Control Line Kits:</b>		<b>For the Race Car Enthusiast:</b>	
The "Squaw"	\$ 4.95	O & R Race car (less motor)	\$ 5.95
The "Chief"	5.95	T.D. Jr (w/engine)	12.95
Jiggers	3.45	McCoy Midget	16.95
Madman Sr.	10.00		
Dumas Elec. Drive Unit	6.95		
Madman Jr.	6.95		
Freshman	2.48		
<b>Misc. Kits</b>		<b>Misc. Kits</b>	
1903 Rambler	2.95	*Rolling Pin Planter	.69
1908 Model T Ford	2.95	Conestoga Wagon	2.85
1910 Model T Ford	2.50	*Brougham	1.95
1911 Maxwell	2.50	*Horseless Carriage	1.50
Oldsmobile	1.95	*Surrey w/fringe on top	1.75
Stanley Steamer	2.95	*Victoria w/calash top	2.35
Amoskag Steamer	6.50	*Chuck Wagon	3.95
Clipper Clock	2.00	*49'er Burro	2.50
*Shadow Box	1.00	*Covered Wagon	3.95
*Cigarette Cart	.39	*Stage Coach	3.95
		*Mexican Ox Cart	2.25
		*Sportsman Convertible	1.00
		*V8 Hot Rod	.85
		*Jeepster	1.00
		*Deluxe Midget Racer	1.50
		*Wishing Well	1.95
		*Constellation (plastic)	1.00
		*Hawk F-84 (plastic)	1.00
		*F-80C Shoot. Star (plastic)	1.00
		*Skyrocket (Plastic)	1.50
		*Means California Merchandise	

### HOW TO ORDER PREPAID—NOW!

Send remittance in full—we will pay postage, insurance, handling. Minimum order \$1.00. California residents please include 3% Sales Tax. C.O.D.—Send just \$1, we will ship collect same day. SERVICE MEN! "Special Handling"—No charge—on prepaid A.P.O. and F.P.O. orders, 15c postage on all orders under \$2.00 in U.S.A.

# Crescent

## MODEL SHOP

5620 West Pico Blvd., Los Angeles 35, Calif.



NOW... use the DOPES  
used on  
REAL AIRCRAFT!

**SPEED-O-LAQ**

**FLIGHT TESTED**  
**AIRCRAFT FINISHES**

THIS  
FAMOUS LABEL  
CAN BE SEEN  
AT LOCAL  
AIRPORTS  
EVERYWHERE!



60¢  
8-OUNCE  
JAR

35¢  
4-OUNCE  
JAR



10¢  
BOTTLE

AVAILABLE IN **23 COLORS**

IDENTICAL TO STANDARD AIRCRAFT COLORS

Cub Cream • Taylorcraft Cream • Aeronca Yellow •  
Taylorcraft Yellow • Cub Yellow • Army Yellow •  
Aeronca Orange • International Orange • Insignia Red  
• Tennessee Red • Universal Maroon • Cessna Gray •  
Waco Blue • Cub Blue • Insignia Blue • Metallic Blue  
• Stinson Green • Cub Green • Olive Drab • Chocolate  
Brown • White • Black • Silver • **OTHER FINISHES:**  
Clear • Gloss Top Coat • Thinner • Banana Liquid •  
Sanding Sealer • Hot Fuel Proofer Clear • Hot Fuel  
Proofer Thinner

Pioneers in aircraft finishes for more than a decade

**SPEED-O-LAQ PRODUCTS CO., INC.** 2386 Wycliff Avenue  
St. Paul 4, Minnesota

**COMPLETE ANALYSES OF 12 WARPLANES**

EACH booklet presents the complete "story" of a world-famous warplane including:  
• Detailed analysis of structure, mechanisms, systems, equipment, armament and performance.  
• Large, carefully scaled 3-view drawing with valuable cross sections.  
• Chronological history of successive models.  
• Complete photographic history of the many modifications in design.  
Single copies, 25c each; all 6 in Group I for \$1.25; all 6 in Group II for \$1.00; ALL 12 IN BOTH GROUPS \$2.00!  
AIR AGE, INC., 551 FIFTH AVENUE, NEW YORK 17, NEW YORK

- GROUP I—FIGHTERS**  
No. 1—Lightning P-38  
No. 2—Thunderbolt P-47  
No. 3—Hellcat F6F  
No. 4—Warhawk P-40  
No. 5—Corsair F4U  
No. 6—Mustang P-51  
**GROUP II—ARMY BOMBERS**  
No. 18—Mitchell B-25  
No. 28—Liberator B-24  
No. 38—B-15 and B-19  
No. 48—Flying Fortress B-17  
No. 58—Wrauder B-26  
No. 68—Superfortress B-29

**The Ideal Gift for the Hobbyist and Collector!**

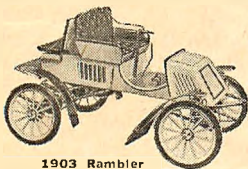

1903 Rambler  
6 1/2" long. \$2.50

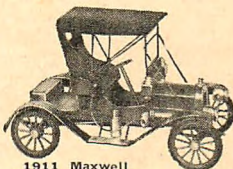

1911 Maxwell  
7 1/2" long. \$2.50

**Hudson Miniatures'  
"OLD TIMER"  
Auto Kits**

Featuring the latest addition to our line The 1903 Rambler, fore-runner of the Nash Auto

Authentic in detail and colorful in appearance, a Hudson Miniatures' "Old Timer" Auto Kit will delight the hobbyist, collector or auto enthusiast in your family. These 3/4" scale models of famous early autos make a handsome decoration for offices, club rooms and dens. "Old Timer" autos are easy to assemble... no cutting or tedious fitting required. Prefabricated kits are complete with instructions. All parts are of cast plastic and die-cut wood and special process board that is cut to length. Order now for Christmas. No C.O.D.'s. Please include 25c for postage and packing.

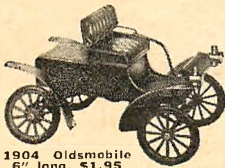

1904 Oldsmobile  
6" long. \$1.95

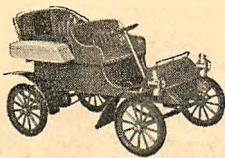

1903 Model "A" Ford  
6 1/2" long. \$2.50

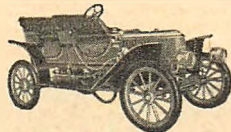

1909 Stanley Steamer  
8" long. \$2.95



1910 Model "T" Ford  
8" long. \$2.50



1909 Model "T" Ford  
8" long. \$2.95

**SCRANTON HOBBY CENTER**

315 Adams Ave., Dept. 6, Scranton 10, Pa.

**Model Portraiture**

(Continued from page 12)

The diameter of a supplemental lens is immaterial so long as it is greater than that of the front lens of the camera. A portrait attachment, a field glass lens in its rim and a telescope lens in its rim are shown supported in a turned wooden cone in one of the drawings. A mahogany or maple cone is suitable. The cone holds the lens' rims frictionally. Care should be used in turning the inner diameters of the cone as they are somewhat critical to produce the desired friction fits. The fit should be slightly loose so that a coat of flat black paint can be applied to the inside of the cone. Any diameter too large can be reduced by building up the surface before painting with narrow strips of gummed paper tape until the desired fit is had.

The author's three supplemental lenses are capable of producing 6 lens combinations in addition to the camera lens. A chart for such use is given herewith. This will serve to show how you can make a chart by using the ground glass focusing method described, to cover whatever lenses you may have on hand.

**TABLE 1. LENS CHART**

Subject to Supplemental Lens Distance in Inches

Focusing Scale Notch (feet)	Lens Combination by Lens Numbers					
	0 (Camera Lens Only)	1 (Portrait Attachment)	2 (Telescope Lens)	3 (Field Lens)	3+1	3+2
15	35	21-3/4	8-7/10	7-9/16	7	5
33	38	23	8-1/10	7-11/16	7-1/32	4-3/4
33-3"	42	24-5/8	8-3/4	7-25/32	7-1/16	4-7/8
4	47	25-1/2	8-7/8	7-7/8	7-1/8	5-1/8
6	58	28	9-3/16	8-1/16	7-5/16	5-1/16
6-6"	58-9"	31	9-7/10	8-1/4	7-1/16	5-1/32
8	7-8"	34-1/2	9-11/16	8-7/16	7-9/16	5-3/8
10	9-6"		9-7/8			5-7/16
15	14-4"		10-1/8			5-1/2
25			10-5/16			5-17/32
100			10-1/2			5-9/16

The cone can be finished outside as desired. Oil and shellac applied while rotating the piece in the lathe produces an excellent professional appearance. After completion, clean the inside thoroughly, and clean the lenses also, as they are probably finger marked as a result of handling when fitting them to the cone. While rimmed lenses are illustrated, unrimmed lenses can of course be used and cemented at 3 or 4 points.

**CAMERA MOUNT WITH CORRECTION FOR PARALLAX** and with **VERTICAL AND HORIZONTAL SWING**—The camera mount consists of a camera support, connected by parallel links with a link mount, on an L-shaped support and an upright from the tripod base. The L-shaped support is pivoted to the upright for swinging the camera from the normal position (for taking horizontal pictures when desired). This arrangement permits focusing through the view finder with it and the camera always in the vertical position.

The view finder on the 1-A Kodak is pivoted for vertical or horizontal snap shots and has a cross-shaped outline for viewing either vertical or horizontal subjects. By leaving it permanently in the vertical position and providing for swing of the camera from vertical to horizontal, only one setting of the parallax correction linkage is necessary and the mechanism is thus simplified. The pivot must be located exactly on the axis of the lens, which is the same as the center of the film exposure opening at the back of the camera.

"Parallax" is the error in focusing introduced by reason of the view finder being off-center in relation to the lens' axis. The lens "looks" at the subject from one position in space while you look through the view finder at the same subject, but the finder is located at another position. The error is slightly noticeable in pictures of subjects 6' to 8' from the camera but usually is unnoticed when the subject is farther away. When portrait attachments are used for close-ups, the error is much greater. When three supplemental lenses are used to get 6 diopter results, the error is so great that the center of the subject when centered in the view finder would be near the corner of the photograph when finished

unless proper parallax correction is made.

The simplest mechanical contrivance for parallax correction is a mounting that permits the camera to be accurately shifted after focusing so that the axis of the lens then falls on the same axis that originally extended through the view finder. At the same time, the shifting camera axis must remain accurately parallel to the original axis. Four parallel links are excellent for this purpose. Their length is immaterial, 2" or 2-1/2" being suitable, but the distance and angle of shifting are very important. The drawing shows that this distance (d) should be the same as the distance D between the center points of the lens and the view finder, and the angle (a) should be the same as the angle A between these two center points to get the necessary results.

In making up the L-shaped support, link mount, camera support and parallel links, extreme accuracy as to the spacing of the holes cannot be stressed too much. Inaccuracies result in binding action when shifting the camera and are very likely to throw the camera out of line during shifting.

The eight wood screws for the link pivots should be of the flat head type, tightened just enough to take up all play without binding. The camera is focused in the lowered position and then raised for taking the picture. A filler block serves to hold it in the raised position. If a horizontal picture is desired, merely swing the L-shaped support to the dotted position. The different positions possible with this system was shown by means of double exposures in the lower pictures on page 18 in Part One of this series (November, 1949, issue).

(To be continued)

## Woody's Wagon

(Continued from page 21)

of dope, and mixing thoroughly).

Apply three coats of wood filler to the fuselage and rudder, sanding between coats. Cement the rudder on the stab.

Trim the model with the color of your choice, and apply a coat of good fuel proofer (Kerr's and Comet's fuelproofer are both very satisfactory).

Test flying is very simple. Incorporate a little right thrust by placing a thin washer between the engine mounting plate and the firewall on the left side.

Fuel shut off consists simply of a seven-inch length of plastic fuel line installed as shown in the close-up of the engine. You will find that the engine will run approximately 25 secs. after the fuel line is pulled off the tank. Hence, you will have about 5 secs. in which to make final needle valve adjustments before launching. Experiment with your engine to determine the exact length of fuel line to use; you can select lengths for 10-, 15- and 20-second motor run, if you wish.

The dethermalizer is the pop-up-tail type. The tail is held on by rubber bands strapped around the fuselage and under the peg in the rudder proper. The trailing edge is held down by a short rubber band strapped tightly between this peg and the peg in the sub-rudder. The dethermalizer is actuated by a fuse inserted between the strands of the latter rubber band. The fuse is made by soaking heavy string (about 3/32" diameter) in a saturated solution of saltpetre for 30 min. and allowing to dry thoroughly. This type fuse will burn at the rate of two min. per inch of length. Use a two-inch length of thread to stop the tail at about a 20° angle.

The model should balance approximately at the rear wing spar. Make small corrections with modeling clay.

# Get and Give these Wonderful MONOGRAM KITS for a Merry Christmas



Choose Monogram Models for yourself or for gifts to others for a real Merry Christmas. Easiest of all to build — more fun — more satisfaction — models you will treasure and keep.

### SPEEDEE-BUILT FLYING MODELS

With plastic props and cowls and all finished parts. For rubber or small engine power.

- 1 — Aeronca Sedan
- 2 — Boeing Kaydet PT-17
- 3 — Midget Mustang
- 4 — Monocoupe
- 5 — Piper Cub
- 6 — Ercoupe

Each Kit, 75 Cents

### JET RACERS

Bodies fully carved. Power with jet tube.

- 7 — Mono-Jet, 85c
- 8 — Terra-Jet, \$1.00
- 9 — Midjet, 85c
- 10 — Hot Shot, 60c
- Aqua-Jet, Hydroplane (not illus.), 60c

### SHIPS

Famous historical models are back again. 16 inch fully shaped hulls.

- 11 — Carrier USS Shangri-La
- 12 — Battleship USS Missouri
- 13 — Destroyer USS Hobby

Each Kit, \$1.00

You can get Monogram Models at good dealers everywhere. See them today. Enjoy the fun of building, flying and racing these outstanding models.

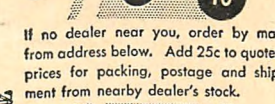

### CONTEST MODELS

Rubber powered flyers for class "C". Use also with CO-2 engines.

- 14 — Prowler, stick model, national record winner, 28 inch.
- 15 — Pirate, cabin model, 31 inch.

Each Kit, \$1.25

### CONTROL FLYERS

Exact scale control line models for engines .19 to .49 cu. in. disp. All finished parts. 35 in. wing span.

- 16 — Aeronca Sedan
- 17 — Piper Cub Special

Each Kit, \$4.95

Monogram MODELS, INC.

225 N. RACINE AVE. CHICAGO, 7.

# It's TRIM-endous

Each booklet contains detailed instructions on cover as illustrated below.

**THIS NEW  
EASY METHOD  
OF TRIMMING**

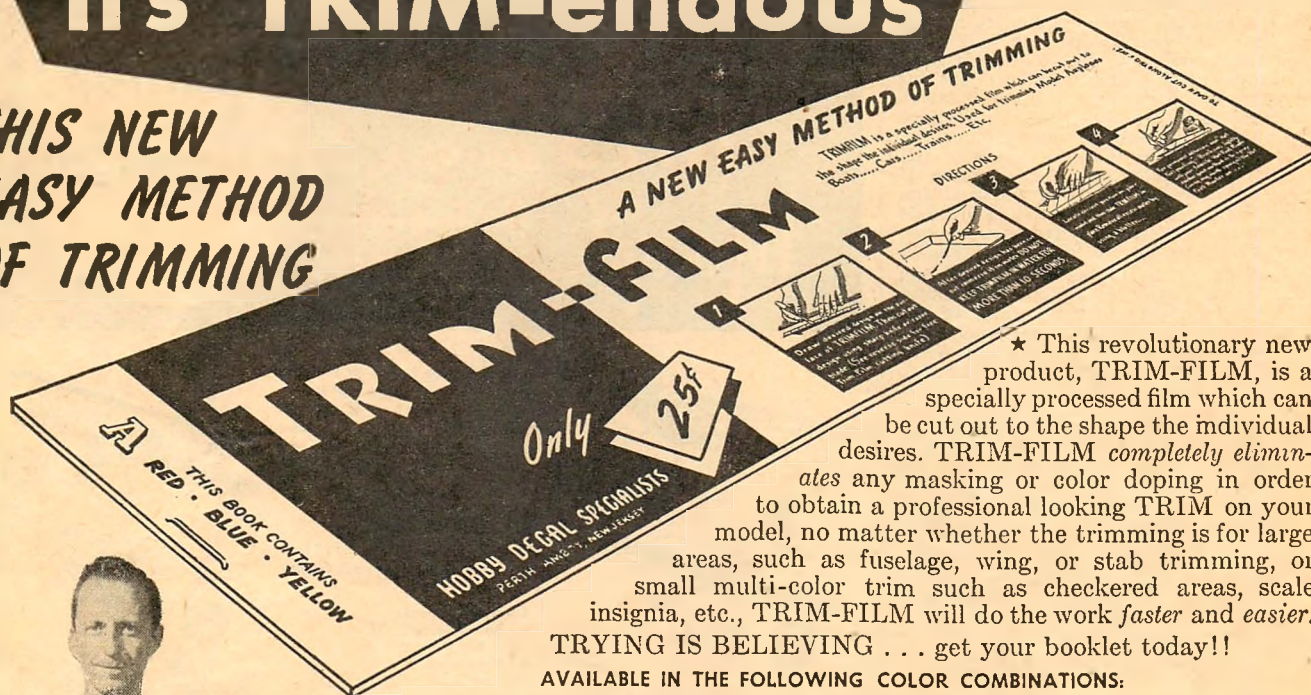

Top-Notch model builder and designer FRANK EHLING says: "TRIM-FILM HAS ACTUALLY CUT MY TRIMMING TIME IN HALF!"

★ This revolutionary new product, TRIM-FILM, is a specially processed film which can be cut out to the shape the individual desires. TRIM-FILM completely eliminates any masking or color doping in order to obtain a professional looking TRIM on your model, no matter whether the trimming is for large areas, such as fuselage, wing, or stab trimming, or small multi-color trim such as checkered areas, scale insignia, etc., TRIM-FILM will do the work faster and easier. TRYING IS BELIEVING . . . get your booklet today!!

AVAILABLE IN THE FOLLOWING COLOR COMBINATIONS:

(A) RED - YELLOW - BLUE (B) ALUMINUM - GREEN - ORANGE (C) WHITE - GOLD - BLACK

ASK YOUR DEALER TODAY

## HOBBY DECAL SPECIALISTS

PERTH AMBOY · NEW JERSEY

Offset the rudder about 1/8" for a left turn, and glide test. The glide should be very flat and moderately slow. Add small shims under the leading or trailing edge of the stab if adjustment is required. Make the first powered flight with the engine running slightly rich. The model should climb in a large right-hand circle. As power is increased, the climb will become steeper and steeper. The optimum climb for this ship seems to be about 60° up. And with the engine wide open, the ship will look mighty small at the end of a 20-second engine run. Incidentally, the ship takes off unassisted after about a two-foot run.

### BABY PHOENIX



Designed by Frank Ehling

- High performance contest model.
- Cub or Spitfire engine power class.
- Jasco balsa wood.
- Die cut ribs, shaped leading and trailing edges.
- Pop up tail dethermalizer.
- Includes gas container that needs no timer.

\$ 1.75 by mail \$ 2.00

JUNIOR AERONAUTICAL SUPPLIES CO.

203 East 15th Street New York 3, New York

### Albatros Pole-Liner

(Continued from page 15)

round. The fuselage is slotted to accept these tail surfaces and they are then cemented in position.

The wings are now cemented together—that is about all there is to it! Just lay out the leading edge along with the tips and trailing edge and then cement in the rib pieces of 1/16" sheet that are later sanded to the airfoil section shown on the plan. When the wings are completed, they can be covered with silkspan. The lower wing can now be cemented in place, as this will not be in the way when the painting is going on.

The entire model should be given a few coats of clear dope, sanding in between to give a smooth finish. The finish color is light blue with white bands, red trim, and black crosses. (See cover of this issue for details of coloring.) After painting the entire model its final blue color, the finish details of white, red and black are best added by means of one of the solid color decal materials, such as Trim-Film. This will assure a neat job without smears, and will eliminate masking troubles.

The wing wires can now be installed, and if they are cut a little longer than necessary for exact fit, they can be fitted without cement in holes punched in the balsa, and can be removed at any time without disturbing the paint job. The windshield can now be cut and cemented in place.

The model must be fuel-proofed if it is to stand any use and still look well. And that is all that is needed to get the model in the air. However, that will be only the beginning if the model is to continue to look well; after flying, wash it off and when you fly again, the model will look as though it had just left your shop.

Although all control surfaces on the original were made movable, this is not really necessary. In fact, no movable surfaces at all are needed, as we recommend that a model of this type be flown as a

"pole-liner." The idea here is just to tether your ship to a pole, with the single wire or cord short enough so that the model cannot quite touch the ground when hanging straight down. It must, of course, be hand-launched, and after the motor cuts, it will drop down in decreasing circles, until the flier can grab it, or it can be allowed to settle safely against the base of the pole.

The single flying line is led through the support labeled "Flite guide" on the plan side view. The end of the line can be fastened to one of the screws that holds the motor in place. With the line in this position, it has generally been found unnecessary to use either rudder or motor offset. One last point—be sure the pole end of the line is able to swivel freely—it is a horrible sight to see your pride and joy winding inward on a stuck line, circling faster and faster and faster, until . . . !!!

### MODELS

- AIRPLANES
- TRAINS
- BOATS
- SUPPLIES

Wholesale  
Distributors  
for 41 years

24-HOUR  
SERVICE



ATLANTA  
GEORGIA

**Walthour  
and Hood  
company**

SOLID COVERAGE over the SOLID SOUTH

# PRECISION DEEZIL \$2<sup>95</sup>

World's Biggest Buy at the World's Lowest Price

YOU CAN'T BEAT THIS PRICE.

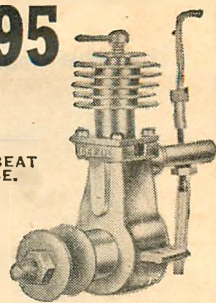

## Check These Superior Features

✓ DEEZIL is compact, rugged, streamlined. Starts quickly. Easy to install. Will run for years.

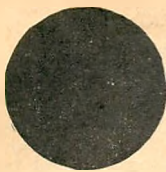

OUR 219TH ADVERTISEMENT

✓ DEEZIL is an ultra precision engine, as carefully machine-tooled as GIANT Army engines. Cylinder is honed to .0001 inch, and hand-fitted to its individual pistons.



OUR 219TH ADVERTISEMENT

✓ DEEZIL is the perfect power plant for planes, boats, and race cars. (Runs at 7500 R.P.M. Produces 1/7 HP)

✓ DEEZIL is light enough for the tiniest jobs (weighs only 5 oz.) POWERFUL ENOUGH to pull a six foot free flihter straight up.

✓ DEEZIL is easy to assemble. No ignition headaches. Step-by-step instruction sheet is included with each kit.

## How To Order By Mail

It's easy. Send \$2.95 plus 25c postage by cash, check or money order.

*We Ship Immediately*

## GOTHAM HOBBY CO., 107 East 126th St., New York 35, N. Y.

### Convair XF-92A

(Continued from page 19)

twice the speed of sound. Therefore, don't let talk of supersonic speed with swept wings fool you: while the airplane may be flying at nearly twice the speed of sound, for all the wing pressure distribution knows, you are only knocking along at a mild subsonic speed!

But if you lay out an airplane with 60° of sweep in its wings, you'll see that the wing tips project pretty sharply back leaving very little open space between the wing trailing edge and the fuselage. So—we simply fill in this space with wing area by connecting the two tips with a straight line. The result: a "delta-wing" airplane (named after the Greek letter Δ—Delta). Obviously, this "radical" new wing planform is simply a logical development of wing sweep, but it has other important advantages. For example, a steeply-swept wing is a very difficult structural problem. As the airload is applied, instead of the tips twisting up slightly as in the straight-wing, the motion of the wing is to change its angle of incidence progressively along the span, resulting in an "unloading" of the lift. Simultaneously, a terrific load is placed in the wing root, particularly at the rear spar connection with the fuselage. With the delta-wing, however, a sturdy, straight spar can be run directly across the wing from tip-to-tip with the result that no twisting action is produced.

Another important advantage of the delta-wing is its peculiar aerodynamic qualities. In the conventional straight-wing, the center-of-pressure moves forward as the angle-of-attack is increased, thereby producing an increasingly unstable situation. Not so with the delta-wing, whose center-of-pressure remains fixed regardless of its angle-of-attack. This means, simply, that the delta-wing is inherently stable longitudinally. But, like all things aerodynamic, this advantage is accompanied by severe disadvantages. One of these is an extremely low lifting ability for the delta-

wing. Because of this, it must operate at a very high angle-of-attack in order to produce the same amount of lift as an equivalent straight-wing airplane. Also, it is unstable laterally since its tips come out to a point and therefore provide little or no lateral damping.

There are a number of other strange aerodynamic characteristics of the delta-wing which are not yet completely understood. Its behavior at the stall (which is up around 40° or more!) is unpredictable; it undergoes odd changes in spanwise lift distribution at various speeds, and data on the use of controls along the trailing edge of a delta-wing are confusing. Thus, this tangled theory does not provide the sure, clear signposts for design that does straight-wing theory and suggests an extensive program of flight tests before wide use of such a wing planform is made. And thus the Convair XF-92A.

The basic idea of a delta-wing airplane originated with Dr. Alexander Lippisch, German scientist and glider expert. Lippisch was interested during the war in the ramjet engine; and after developing such an engine, he decided to design an airplane in which to test it at supersonic speed. Lippisch designed a delta-wing airplane which was built by Darmstadt and was ready for flight tests when Allied soldiers suddenly moved in on the proceedings with unappreciated gusto. However, both Dr. Lippisch and his airplane were brought to the United States shortly after V-E Day. The airplane went to Wright Field, property of the Air Force, and Dr. Lippisch went to the Philadelphia Navy Yard, property of the U.S. Navy.

Consolidated Vultee Aircraft Corporation was awarded a contract for an XF-92 supersonic delta-wing fighter powered by a small turbojet engine (for take-off and cruise) and a bank of liquid-fuel rockets for high speed interception work. This contract was awarded in the fall of 1945 and work progressed on the radical new design at the San Diego plant while wind tunnel tests

### JUELINE 4-IN-1 BLADE HOLDER

- Single Edge Knife • Double Edge Knife • Chisel • Screw-driver • Light Aluminum Case
- Retractable Blades • Two Double-End Blades Furnished
- Pocket Clip • Adjustable
- Easy to Operate • Price \$1.00
- Postpaid • No C.O.D. please
- Dealer and Jobber inquiries Invited.



LAR/LIN Products  
2338 15TH AVENUE,  
ROCKFORD, ILL.

### Spectacular NEW Speed-Champ

## HELL-RAZOR

Class 'D' Senior Record-Holder  
ALLOY-  
MAGNESIUM BOTTOM

159.23 MILES PER HOUR

### COMPLETE KIT \$6<sup>95</sup>

Redi-Cast, magnesium alloy bottom; Carved Pine Fuselage Top, Shaped Pine Wing; Shaped Balsa Fairing Block, Fuel-Tank Material; Flightex Hinges, Hardware, Plans

REDI-CAST Mag. Alloy Shell only \$2.95 (plus 35c delivery charges)

HELL-RAZOR is the speedsters dream. 18" span, 17 1/4" fuselage, weight 31 oz. Innumerable tests prove HELL-RAZOR to be a longer lasting, safer and easier to fly model. Model featured in this issue. Other classes available soon. Order now for early delivery.

MANY OTHERS—LIST FREE

**Consolidated**  
3087 THIRD AVENUE, NEW YORK 56, N. Y.



**DOOLING** has something . . .  
of interest to anyone who builds models!

It's the **BRAND NEW "DOOLING 29"**

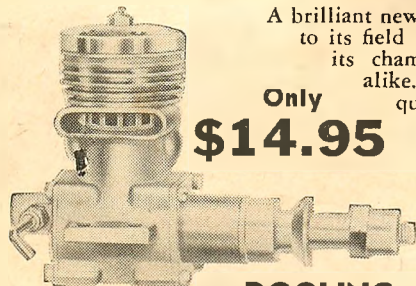

A brilliant new engine that bears the same relationship to its field that the famous "Dooling '61" holds in its championship class. They look alike—act alike. Sisters under the skin. The utmost quality at reasonable cost.

Only  
**\$14.95**

Specifications on The "Dooling 29"

Bore .800  
Stroke .614  
Bare weight 6 1/2 oz.  
Aluminum piston, with rings  
Crankshaft mounted with two ball bearings  
Molybdenum iron cylinder liners  
H.P.—3/4" at 17,500 r.p.m.

Regulation Discounts  
to Dealers and Jobbers

**DOOLING BROTHERS**

5452 West Adams Boulevard • Los Angeles 16, California

**SMITH COILS**



"First because they Last"

Competitor **\$1.95**

Firecracker **\$2.75**

**SMITH COILS** 105 Pasadena Avenue  
South Pasadena, Calif.



**M.E.W.  
601  
JET  
ENGINE!**

You'll have lots of fun with this world famous miniature jet engine. Perfect for cars, boats and planes. Only 6" long, M.E.W. 601 can be assembled in 10 minutes. Easy starting . . . runs on gasoline. If dealer cannot supply send \$3.00. Construction plans *only*, \$1.00. Test Stand for running indoors, \$3.00.

**MINNESOTA ENGINE WORKS**  
387 UNIVERSITY AVE., ST. PAUL 3, MINN.

Added to this they installed a Solar after-burner, which neatly doubles the power output of the engine for short bursts of speed. They spared no pains in building a strong, finished structure. Thus, many observers are convinced that the Convair XF-92A is in every respect a full-fledged combat airplane and a far cry from the "flying mockup" tag hung on it during its construction. Actually, they say, the airplane is fully capable of supersonic speed.

There are two factors, each equally important, which should make this so. Firstly, bearing in mind the fact, stated earlier, that the 60° angle of sweep of the XF-92A leading edge permits the airplane to fly at well past the sonic barrier before the critical Mach number of the wing is closely approached, it would appear that the plane has the aerodynamic qualifications for the job. With more than 10,000 lbs. of thrust available it most assuredly has the power.

But of equal, or perhaps greater, importance is the fact that the Air Force recently revealed that none other than Capt. Charles E. Yeager had been assigned as test pilot for the Air Force phase of the flight tests. Yeager is world-renowned as the first human being to travel faster than the speed of sound, which he accomplished August 14, 1947, in the Bell X-1 supersonic research airplane. For this historic feat he received the 1947 Collier Trophy and numerous other special awards (but not including a promotion!). Certainly with "Chuck" Yeager at the controls, the XF-92A is going to do all of which it is capable.

And if this delta-wing fighter is capable of supersonic speed then it's a foregone conclusion that Yeager will attain that performance, which certainly isn't too bad for an airplane that the greatest aeronautical scientists in the world tell us is nothing in the world but one of our classroom paper darts!

**Report from the West**

(Continued from page 6)

ginner—H. C. Albright 134.32; Les Douglass 96.51; *Class A Precision Expert*—John Lenderman 371 pts.; Bud Ross 350 pts.; *Advanced*—Kenneth Walker 35 pts.; *Beginner*—Frank Griffen 128 pts.; Wilson Alexander 118 pts.; *Class B Precision Expert*—John Lenderman 390 pts.; Bud Ross 384 pts.; *Advanced*—Norman Wilson 379 pts.; Kenny Adams 329 pts.; *Beginner*—Al Ennor 262 pts.; E. J. Alexander 261 pts.; *Class C Precision Expert*—Bob Palmer 427 pts.; Dick Shelton 392 pts.; *Advanced*—Lee McKown 357 pts.; Truman Humphries 321 pts.; *Beginner*—Al Funkner 286 pts.; John Morton 239 pts.; *Class D Precision Expert*—M. C. Kyle 883 pts.; W. C. Rice 286 pts.; *Advanced*—Carol Sligar 359 pts.; Gail Echstein 349 pts.; *Beginner*—John Morton 338 pts.; E. Underwood 324 pts. Dick Tretheway, of Vallejo, won the *Jet Event* with 138.03 mph, and Ilse Favre, of Hayward, topped the *Ladies Event* with 99 pts. Roy Mayes took *Flying Scale* with his *Buster* model, while M. D. Avery won the *Exhibition Scale Event* with his *F7F Tiger Cat*. Contest Director Ralph Bamicigno, with the help of his *Modesto Flying Circus* modelers and the *Modesto Exchange Club*, are to be congratulated for another fine Meet.

Seen at Western and Rosecrans several times recently was James Martin, of Los Angeles, and his "Flying Airfoil Section." This unique aircraft is very stable and really does beautiful rolls in the climb. It's powered with a *Madevell 14* and is full of gadgets to operate the engine, flaps, and spoilers. It has a definite flight pattern and at the top of the climb the engine throttles down to a four-cycle and the flaps and spoilers go into action and the aircraft descends. The instant it touches the ground a trip cuts the engine and the flight is over. It takes Martin about three minutes to cock all the levers and prepare his job for another flight.

Troy Burris, past president of the *Lake-wood Model Club*, of Long Beach, is back from Germany. Troy told us he flew 166 missions on the *Airlift*. After his leave and visit to Long Beach, Capt. Burris will go to

**— ROCKETRY —**



THE  
A-1  
BOOK  
ON  
ROCKET  
AND  
JET  
PLANES  
2nd  
EDITION

ROCKETS & JETS

By Constantin P. Lent

Industrial Designer, Former Vice-President of The American Rocket Society. Present National Director, National Rocket & Jet Society.

Be informed. Read this semi-technical book on Rocket and Jet planes. It is easy to understand, simple and concise. Indispensable to designers and inventors. 250 pages, 150 illustrations. List of 200 British and U.S.A. patents. List of Rocket Societies.

**COSTS ONLY \$5.00 P.P.**

**TO ORDER WRITE  
ROCKETRY  
350 Greenwich St.,  
New York, N. Y.  
(Dealers Protected)**

and theoretical research went forward at the NACA Ames Aeronautical Laboratory, Moffett Field, Calif. When some of the peculiar aerodynamic results began to come through from these studies, the Air Force and Convair agreed that they had a bear by the tail and, instead of rushing the airplane through to completion, it was decided to slow down while more information was obtained. Convair suggested a flying mock-up of the airplane to serve as a special research plane in order to obtain some actual piloted flight reports on the handling characteristics of the delta-wing. The Air Force agreed and Convair set to work to build the Model 7002.

Basically, the Model 7002 was the XF-92 in general arrangement but, instead of the radical and untested rocket power plant, it was decided to install the tried-and-trusted Allison J-33 turbojet engine in a full-size fuselage. The odd-shaped plane was completed in the spring of 1948 and made its first, short test hop June 9, 1948. However, this hop was only 10-15' off the ground and test pilot Sam Shannon suggested several changes. These changes delayed the first full-fledged test flight until Sept. 18, 1948, when the new plane was taken aloft to 11,000' and stayed up for 18 min.

It was at this time that a series of strange events took place. First, the Air Force canceled the XF-92 contract altogether, this being the rocket-powered, fuselage-less basic design but agreed, simultaneously, to accept the flying mockup. This, they decided, was actually an airplane and not just a test vehicle, so they designated the Model 7002 the Air Force XF-92A, since it was literally only a modification of the XF-92.

While designed only to provide a flying version on which suitable handling qualities information could be obtained, Convair engineers, nevertheless, did a substantial design job on the airplane. The Allison J-33 engine is the latest model with a power-output of 5,200-lb. of thrust, the most powerful turbojet engine available at the time.

# LOOK! SCIENTIFIC'S NEW "BUCKEYE JUNIOR" SPEEDBOAT FOR ALL SMALL BORE ENGINES

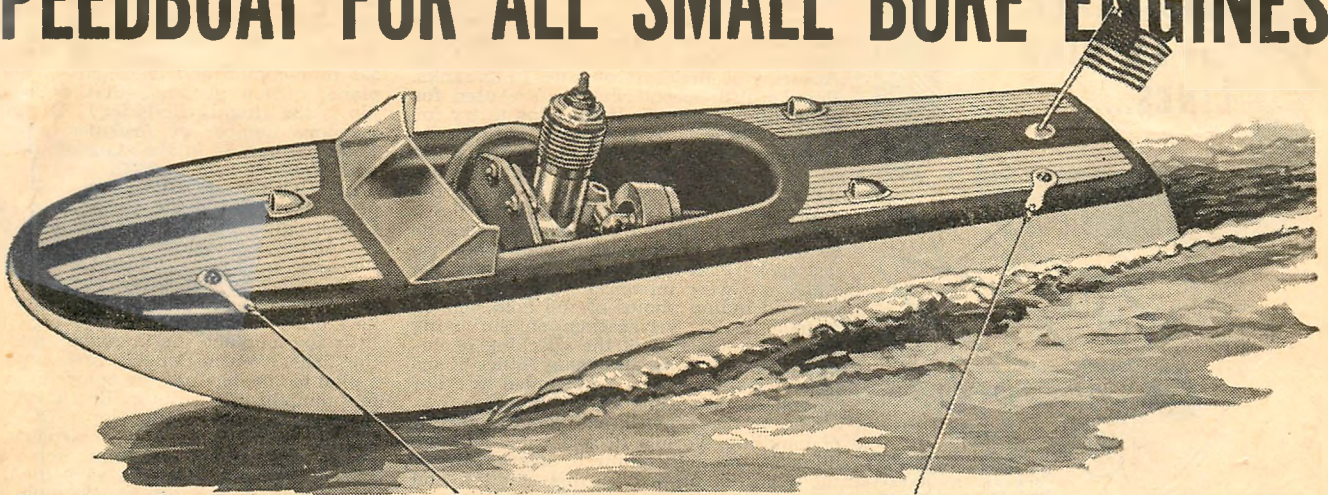

**LOOK**  
COMPLETELY PREFABRICATED



FOR ALL SMALL BORE ENGINES OF .020 TO .099 DISPLACEMENT CO<sub>2</sub> ENGINES OR ELECTRIC MOTORS

GET THE THRILL OF YOUR LIFE WHEN YOU SEE THE BUCKEYE JR. RACE ALONG IN THE WATER.

**\$3.95**

• BUY FROM YOUR DEALER AND SAVE 15c MAIL CHARGE •  
**SCIENTIFIC MODEL AIRPLANE CO.**  
113 M-1 MONROE ST., NEWARK, N. J.

**100% COMPLETE KIT**



**PLUS** GAS TANK MATERIAL, BOLTS, SCREWS, NUTS, WASHERS AND BRIDLE CLIPS, PROPELLER, SHAFT AND HOUSING, RUBBER UNIVERSAL, DIE-CUT PLYWOOD FIRE-WALL, DECALS, FLAG AND INSTRUCTIONS.

Keesler Field, Miss., to study radar. Following nine months' study there, he plans to start his model activity again by building an all-metal C-54 powered by four Class B engines! Flying Scale has always been Troy's pet. At contests in which he flew in the past, he won first practically all the time with either his *Torpedo*-powered P-38, or his DC-3 powered by two *Bullets*; both were equipped with retractable landing gear. Troy plans to feature engine control, retractable gear and workable flaps on his C-54.

Have you seen Bill Sweet lately? Bill, former sales manager with K & B Manufacturing Company, hasn't been seen on the "mike" at contests around Southern California for a long time. We talked with Bill in his new home in South Gate, Calif., and he told us he was doing quite well as a wholesale grocery salesman and likes it fine.

This about winds things up for now—see you next month.

## The Monster

(Continued from page 11)

dethermalizer operates by simply changing the position of the C.G. Fasten the 1/2" x 3/4" steel weight to the end of a piece of thread approximately 29" long. Attach the other end of the thread to the ail end of the fuselage. Hold the weight to the glider nose with a small rubber band, and pass the chalk line wick under this band. After the wick is lighted, it will burn slowly up to the rubber band and the heat will then cause the rubber band to break, letting the weight fall off the nose of the glider and swing back to the tail. This will put the glider in a violent stall to bring it down out of any thermal.

Use a cord about 1/8" diameter for the wick. It must be white. Colored cord

seems either to go out, or will not burn at all. It is not necessary to use any chemical on a good chalk line. It will burn approximately 5 min. for each 3/4" of wick.

This glider was designed for contest flying—I hope you have as much pleasure and fun flying it as we have had.

## World's Records Are Tough!

(Continued from page 25)

radio, sound or other remote control not using wires directly connected to the plane, may be used. So far, only speed is recognized in circular (controle) flight, although there has been some talk lately of endurance records for controle flying.

Basically, this could be summarized that World's records are recognized by the F.A.I. for Duration, Distance in a straight line, Altitude, Speed in straight flight and Speed in a circular course. The 3.93 to 16.38 oz. per sq. ft. wing loading applies to all models except controle jobs where the maximum has been raised to 65.52 oz. per sq. ft. Areas on all models are the projected planform areas of both wing and tail, added together. Cross section requirements for the fuselage are two-fold: for gas models (and jets) it's the total area of wing and stab divided by 80; for gliders it is the total area divided by 100. In the case of Special Aircraft (copters, etc. in Class III) there are no cross section or wing loading requirements. All models except gliders (Class IV) are required to rise from the ground or water under their own power, from a standing start.

Before you go off to the workshop to build the ship that's going to set the new World's Speed Record, we'd suggest getting in touch with AMA. Up to the present time, the only F.A.I. record trials to be held have been sponsored by the Plymouth Motor Car Company and the U.S. Navy for one very basic reason. That simple little catch is the requirement that special elec-

## AUSTIN-CRAFT

Make A-C supplies your "partners for performance". Build easier, fly better!

### TEAMMATES FOR BABY ENGINES

Sensational new flying miniatures of Paul Gilliam's free flight champion City Boy 74.

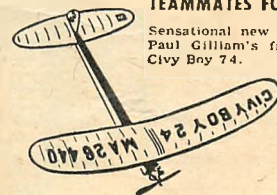

City Boy 24.  
For Infant engine.  
\$1.35

City Boy 31.  
For Baby  
Spinner, etc.  
\$1.65

### FUEL SAVER

Thousands in use! Handy A-C Fuel Can. Refuels without dirt or waste. Leakproof. Fits in tool box. .75c



### MORE GLAMOUR

Dress up your ship with a tear-drop design dural A-C Spinner Nut. 1/4" or 5/16" thread. Specify size. .25c

TO ORDER NOW! If A-C "partner" accessories are not available locally, use this Order Form. On order under \$1, add 10c postage. Enclose Money Order, Stamps, or Check. Please PRINT name, address. No. C.O.D.'s. Tear here.

### AUSTIN-CRAFT CO.

431 South Victory Blvd., Burbank, Calif.

City Boy 24 \$1.35

City Boy 31 \$1.65

A-C Spinner Nut 25c

1/4" or 5/16" thread.

A-C Pump Can 75c

A-C "Old West" Shelf Models:

Stagecoach \$1.50

Buckboard \$1.00

Covered Wagon \$1.50

NAME.....

ADDRESS.....

CITY & ZONE.....STATE.....

**MOD-KRAFF has  
the LEADING  
LINES.....**



Write for Prices and  
Discounts on Your Let-  
terhead. No Retail  
Mail Orders Accepted.

**mod Kraff Co**

840 Union St., New Orleans 12, La.

**Dyna-Model has Three New Kits!**

FOCKE WULF 190 • CORSAIR F4U • WARHAWK P40



P-40 WARHAWK—22 Finished parts	\$2.75
F-4U CORSAIR—16 Finished parts	\$2.75
FW-190 FOCKE WULF—22 Finished parts	\$2.75
P-51 MUSTANG—23 Finished parts	\$2.75
F-6F HELLCAT—23 Finished parts	\$2.75
F-8F BEARCAT—15 Finished parts	\$2.75
P-47 THUNDERBOLT—43 Finished parts	\$2.95
P-38 LIGHTNING—48 Finished parts	\$3.50

Ask your dealer for "Dyna-Mo". If he cannot supply you write us direct enclosing check or money order plus 25c for packing and postage—no C. O. D's.

**DYNA-MODEL PRODUCTS COMPANY**  
76 SOUTH STREET, OYSTER BAY, NEW YORK

HOLCOMB • HOLCOMB • HOLCOMB

**HOLCOMB HAS 'EM!**

MOTORS • KITS • SUPPLIES  
BALSA • DOPES • ACCESSORIES

We carry in stock a complete line of the nationally advertised brands. You name it, we have it—or can get it!

MR. DEALER: Write today  
for Price List!

MAIL ORDER SERVICE: If no Dealer to serve you, write us what you want. Give your nearest dealer name if possible. Prompt service! At this location 12 years.

Write, phone, or stop in today

**Holcomb  
Gas Model Supply Co., Inc.**

Alma, Kansas

HOLCOMB • HOLCOMB • HOLCOMB

tronic timing devices be used for speed. The AMA has one such device, but to have it set up at a record trials cost a considerable amount. You must be prepared to have your model photographed, the course surveyed for accuracy, your engine dismantled by the U.S. Bureau of Standards to have its displacement checked.

For endurance the requirements are simple and well within the range of the average club having a Contest Director of the Academy of Model Aeronautics in its ranks. Regular fifth-second watches are used for all endurance events. If you plan to try for World's Records, it is best to write to the Academy well in advance of the trials, not so much to let them know what you are doing, but to allow them time to declare the approximate date of the trials to the F.A.I. and to inform you fully of the requirements for having the record confirmed. When we last spoke to Russ Nichols, Director of the AMA, we were informed that regular reports including photos of the field, model, statements of verification of surveying courses, statements of the checking of engine displacements and many other items of information had to be included in order to obtain recognition of the record.

Due to the expense and the complexity of handling World's Record trials and the filing of the data required, sponsorship of the trials is needed in this country and quite badly. It is too early to be able to even guess at the contests that will have such trials as part of their events except for the Plymouth International Meet to be held in Detroit late in August, 1950. Here, the Meet is restricted to those who have won local Meets except for the Record Trials under F.A.I. rules, where anyone wishing to come to the Meet may fly. Discussions are underway as you read this, for sponsorship of Trials throughout the country, so watch the columns of MODEL AIRPLANE NEWS for the latest, up-to-the-minute dope.

## Flash

(Continued from page 5)

same manufacturer. But at least one major producer is definitely not interested in the proposition, for William T. Piper is now well along on development of his own agricultural spray airplane! With Luscombe now out of business, that leaves Cessna and Aeronca as the likely contenders and the latter company has expressed the most interest.

THE AIR FORCE has changed its mind again. These columns have faithfully chronicled for you the Air Force decision right after the war to dispense with primary trainers and to start students right off in basic trainers such as the new North American T-28. Then, USAF suddenly decided that primary trainers would be necessary and held a rigorous flight competition at Wright Field between the Temco Trainer, the Beech Mentor 45 and the Navy Fairchild XNQ-1. The latter won a contract for 100 at a cost of \$8,000,000 a year ago, and the Hagerstown, Md., plant of the company began making sub-assemblies for the job. Now, the Air Force has again changed its mind and canceled the Fairchild contract! To top it all off they want to hold another competition which is where we came in. Personally, we think that "Bevo" Howard's amazing demonstration of the Beech 45 Mentor at the 1949 National Air Races has a lot to do with the contract cancellation and it wouldn't surprise us a bit to see the contract go for this neat little trainer. But why didn't the USAF choose it a year ago, instead of costing the taxpayers more than \$1 million in wasted preparations by Fairchild?

UNITED HELICOPTER, Inc., the official name of young Stanley Hiller's helicopter company, has been quietly producing helicopters at the rate of three-a-week at its Palo Alto, Calif., plant until No. 100 is now taking shape! Hiller now claims to be the largest producer of commercial helicopters in the entire world! (And we thought he was still flying his experimental model around the country!) Hiller has already started booking orders for his second hun-

drud aircraft through twelve dealers around the country.

IT'S ALWAYS a little shattering to receive the annual CAA registration of licensed aircraft, for as air-minded as most of us think the U.S. is, we are never quite prepared for the actual truth. CAA says that as of July 1, 1949, there were 91,286 airplanes licensed in the United States! These are broken down into 86,212 single-engine; 4,521 twin-engine; 20 tri-motors; 532 four-engine and one eight-engine airplane. (Stop guessing—that eight-engine job is the Hughes Hercules!) Of this tremendous number of airplanes, a total of 10,452 of them is in the state of California with Texas second at 7,027.

ALTHOUGH FOUR years behind the post-war twin-engine transport parade, Douglas gives signs it may catch up quickly. Douglas produced the DC-9 design at the same time as the Martin 2-0-2 and the Convair Liner (all three very similar in arrangement) but delayed production while he studied the market. He waited just a little too long and the Convair Liner swept the field. When Douglas first announced a plan to "modernize" the beloved old DC-3 few thought him serious. But when Douglas put the super-sleek "Super DC-3" into the air as virtually a new airplane, eyes began popping and accounting departments started figuring. Douglas says the rakish new plane will cruise at 250 mph, carry a 7000 lb. payload, and accommodate 30-37 passengers. Douglas, together with Donald, Jr., recently completed a nationwide selling tour and Capital Airlines broke the ice by ordering an initial group of three with a plan for an eventual twenty. Douglas points out that there are now more than 400 DC-3 transports in service in the U. S. alone, all potential sales for the Super DC-3. Under new rules laid down by the Civil Aeronautics Administration and the International Civil Aviation Organization, existing DC-3's will have to be retired from service by the end of 1952 since they do not meet the more rigorous performance requirements, but the Super DC-3 meets them with room to spare.

IF IT WERE required that we award a prize to the truly most unusual jet aircraft produced in the U.S., we would have no hesitation naming the new Martin XB-51 attack-bomber. The location of two of its engines in short-strutted pods on either side of the fuselage nose, mounting of the stabilizer atop the fin and the use of anhedral (negative dihedral to you!) in its swept wing all combine to give it an appearance something less than conventional. But most unusual feature of the new bomber, despite all this, is the use of variable-incidence control in its wing, an idea that has been tried dozens of times in the past 40 years without success. The idea is to change the angle-of-attack of the wing without changing the attitude of the fuselage or the thrust line of the engines. Martin and Air Force engineers decided to try out this idea for a variety of reasons, one of which was the use of the bicycle landing gear in the XB-51. Since this gear works best when both front and rear wheels are in equal contact, it is desirable that the airplane take-off and land in a horizontal attitude. With the variable-incidence wing, this is accomplished quite easily by increasing the incidence for take-off and slowly decreasing it for high-speed flight. The huge bomber has a crew of only two: a pilot in a clear-view bubble canopy atop the nose and a combination navigator-radio-operator buried somewhere down inside the fuselage behind him.

THE HISTORY of aviation is crowded with pessimists who cried: "This is as big as airplanes should ever get." while pointing to a Navy NC-4 flying boat, a Douglas DC-4 transport or a B-29 bomber. But it's beginning to look like airplane size is beginning, at least, to closely approach its maximum economical size. After less than a year of operation the Navy has grounded the two Lockheed XR60-1 Constitution transports because they are "too expensive to operate." Great Britain states flatly that its new Bristol Brabazon transport, flown for the first time a few weeks ago, will never see airline service but will be used only for "research" work.