

AIRPLANE ENGINES: GLIDING AND SOARING: AIR NAVIGATION

★

# Model Airplane News

15c

Complete Plans for  
Flying Model of  
Rotor Plane  
Bowlus —  
Sailplane  
Model

APRIL, 1931

AND JUNIOR MECHANICS

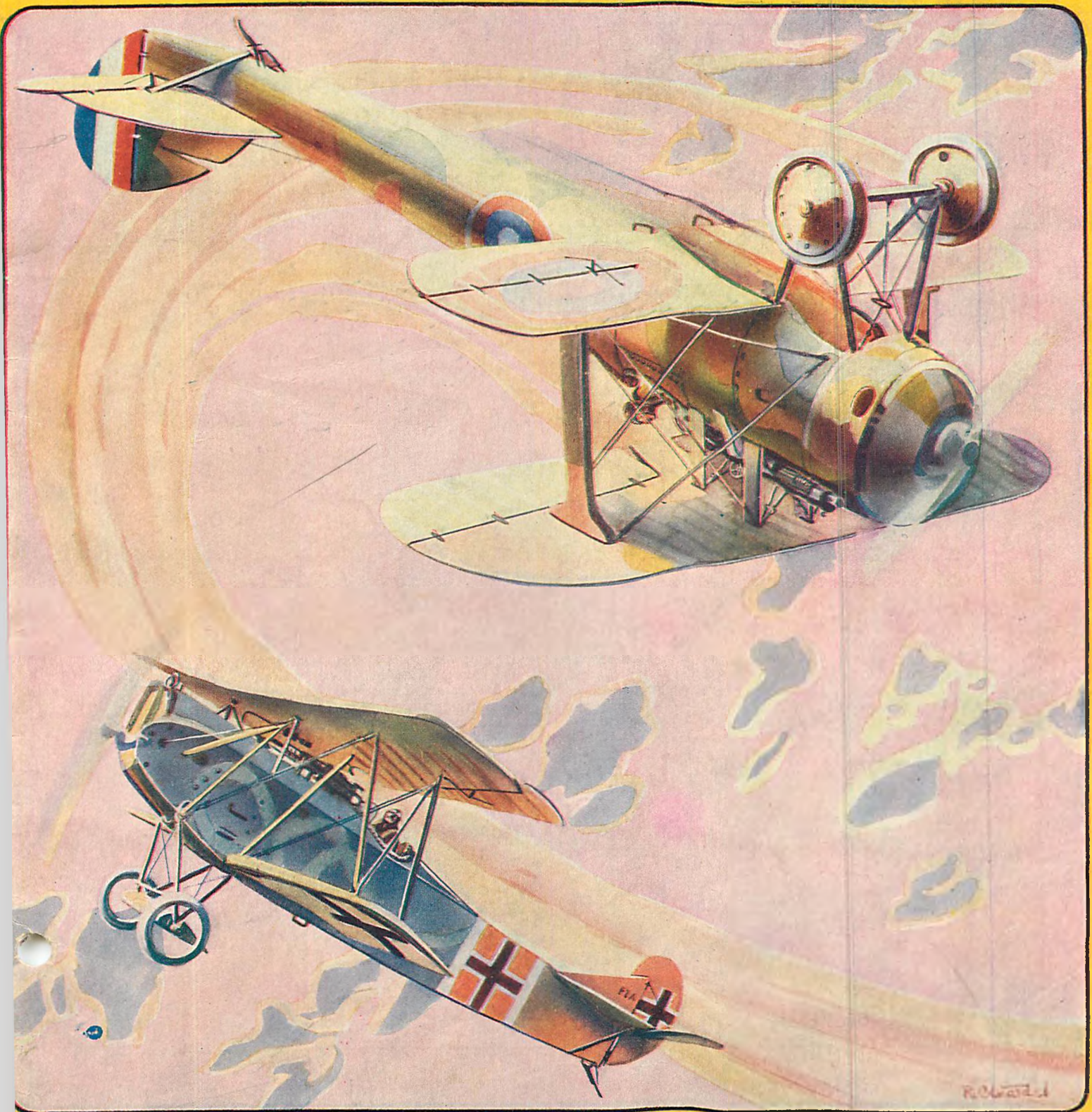

Sopwith "Dolphin" in a Scrap with a Fokker D-7 (World War)

Reid



YOU CAN DEPEND UPON IDEAL FOR A SQUARE DEAL!

# The New IDEAL "Columbia"

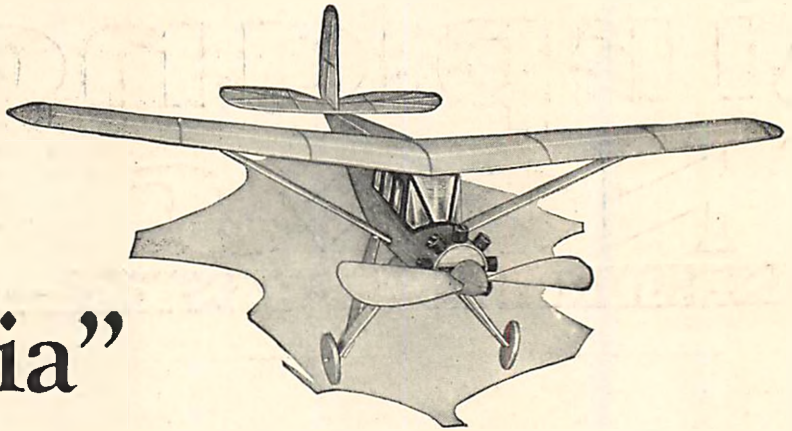

26 in. Model of the Famous Trans-Atlantic Airplane

Here's a Model that will give you all kinds of sport. A real reproduction of a famous Airplane, complete in every respect and ready to construct, for only One Dollar! Large size: 26 in. wing span; made entirely of balsawood; weighs only 1½ oz. complete. It's one of IDEAL'S remarkable feather-weight Models. Fuselage parts stamped to shape; built-up, double-surface wings with stamped wing-tips; special, low-pitch, high speed propeller; spinner ready to shape and parts to make a seven cylinder dummy radial motor. Everything complete (except glue) in a fine Construction Set, including full size Plans and all instructions, at your dealer's or sent prepaid upon receipt of price.

Construction  
Outfit

\$ 1.00

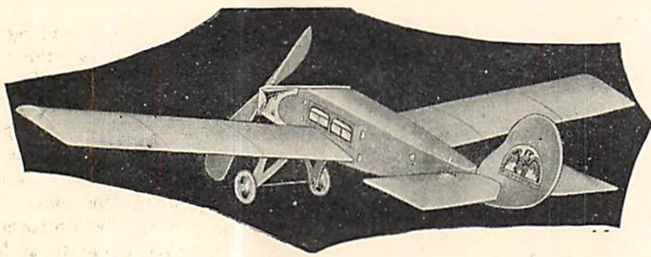

## The IDEAL American Eagle

Wing Span: 26 in. Weight: 3¼ oz.

A distinctive, low-wing type Model, fast flying and more substantially made than most Models. In fact, this American Eagle will be in the air when more delicate Models have been junked. Fuselage and tail assembly are balsawood, fuselage constructed with aluminum bulkheads; wings built-up with formed, high-lift ribs; indestructible landing gear and fibre propeller; special pitch. Set contains everything required, including coloring materials for an attractive finish. Complete Construction Set.....\$2.50

## Have You Seen all the New IDEAL Models?

Send 5 cents for our big, 48-page Catalog of Models, Parts, Fittings and Supplies, including our latest developments in Featherweight Flying Models.

IDEAL AEROPLANE & SUPPLY CO., INC.,  
*The Most Reliable Name in Model Airplanes for 20 Years*

20-24 WEST 19th STREET, NEW YORK CITY

Send Canadian Mail Orders to—CANADIAN MODEL AIRCRAFT, 344 Victoria Avenue, Montreal  
(Canadian Prices are 30% Higher to Cover Customs Duty)

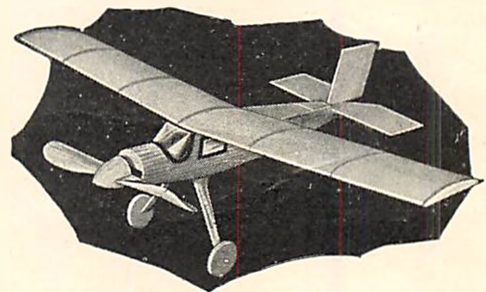

Another New One!

## The IDEAL "EAGLET"

The most remarkable little ship you ever saw! A complete, 20 in. wing span Model; full cabin fuselage type; and made entirely of balsawood (not cardboard) for only 50 cents. And it's guaranteed to fly. Construction Outfit contains all parts and materials required, including many ready-to-use metal and wire fittings. Propeller of formed balsawood, 7½ in. size; ready-cut balsa ribs, and fuselage sides; propeller shaft, propeller hanger, wing clips, landing gear axles and other parts also included. Everything ready to use; you can build several "EAGLETS" in a single day. Get yours now and have some real sport!

Construction  
Outfit . . . 50c

*At your dealer, or sent prepaid upon receipt of price.*



(Continued from page 36)

ers not less than 8 inches in diameter and 7 feet long and marked with alternate bands of white and red, 20 inches in width. The object to which the balloon or airship is moored on the ground shall have the same kind of streamers, which must be in the same position as the lights specified herein. Sec. 78. SIGNALS

(A) *Distress*—The following signals, separately or together, shall, where practicable, be used in case of distress:

(1) The international signal, S O S, by radio.

(2) The international-code flag signal of distress, NC.

(3) A square flag having either above or below it a ball, or anything resembling a ball.

(B) *Signal when compelled to land*—When an aircraft is forced to land at night at a lighted airport it shall signal its forced landing by making a series of short flashes with its navigation lights if practicable to do so.

(C) *Fog signals*—In fog, mist, or heavy weather an aircraft on the water in navigation lanes, when its engines are not running, shall signal its presence by a sound device emitting a signal for about five seconds in two-minute intervals.

Sec. 79. DEVIATION FROM AIR TRAFFIC RULES.

The air traffic rules may be deviated from when special circumstances render a departure necessary to avoid immediate danger or when such departure is required because of stress of weather conditions or other unavoidable cause.

The regulations governing the marking of licensed and unlicensed aircraft are published herewith for the guidance of aircraft owners and for the general information of the public, although they do not form part of the Air Traffic Rules.

MARKING OF LICENSED AND UNLICENSED AIRCRAFT

Sec. 37. MARKING OF AIRCRAFT, LAW OF

"The Secretary of Commerce shall by regulation . . . establish air traffic rules for the . . . identification of aircraft . . ." (Sec. 3 (e).)

Sec. 38. IDENTIFICATION MARKS FOR GOVERNMENT AND SPECIAL CLASSES OF AIRCRAFT.

(A) For aircraft belonging to the Government of the United States identification marks or symbols will be assigned in accordance with arrangements to be made with the affected departments.

(B) Licensed airplanes engaged in racing or experimental work, or specially licensed for other purposes, will be assigned special identification numbers or symbols.

Sec. 39. IDENTIFICATION MARKS FOR LICENSED AIRCRAFT.

A licensed aircraft shall bear an identification mark consisting of the license number of the aircraft preceded by—

The Roman capital letter S (meaning State) for aircraft used solely for governmental purposes and belonging to States, Territories, possessions or political subdivisions thereof, and

Aircraft not licensed, but eligible and for which application for license has been filed with the Secretary of Commerce, will be

## Aviation Advisory Board

assigned only a temporary number pending the issuance of license.

The letter N must precede the license symbol and numerals on licensed aircraft engaged in foreign air commerce and, at the option of the owner, may precede it on other licensed aircraft. *The identification mark will be assigned to licensed aircraft when the aircraft license is issued, and a separate application is not required.*

Sec. 40. IDENTIFICATION MARKS FOR UNLICENSED AIRCRAFT.

(A) Unlicensed aircraft must display, when in flight, an identification mark assigned by the Secretary of Commerce. The mark will be assigned upon the application of the aircraft owner and must be permanently affixed to the aircraft. It will consist of a number only. The nationality mark shall not be made a part of it, nor shall any other letter, design, symbol, or description be added thereto.

(B) On the date of sale or transfer of title of unlicensed identified aircraft the

**Don't Be Misled!**

There is only one MODEL AIRPLANE NEWS!

Reports and rumors to the effect that this magazine has merged with another publication are entirely without foundation.

MODEL AIRPLANE NEWS has not merged, nor has it the intention to merge with any other magazine.

Don't be misled by titles in which the words "Airplane News" appear. Ask for *MODEL* Airplane News—using the word "Model" to distinguish it. THE EDITOR.

vendor shall report in writing to the Secretary of Commerce, advising the date and place of sale or transfer, and the name and residence of the vendee, and on said date shall return to the Secretary of Commerce the metal plate furnished by the Secretary of Commerce and the identification-mark assignment issued for such aircraft.

(C) Upon such sale the identification mark may be reassigned to the vendee, provided he files an original application for identification mark, in duplicate, with the Secretary of Commerce, requesting such reassignment and attaches to the application the bill of sale or a certified copy thereof.

(D) The vendee may operate such aircraft under the identification mark already assigned for a period of 20 days from the date of sale.

(E) Between the date of sale and date of posting in the mails or delivery in person to an authorized representative of the Secretary of Commerce of the new application the aircraft is considered unidentified, and its operation will constitute a violation of these regulations.

Sec. 41. PLACES AND DIMENSIONS OF MARKS.

Identification marks shall be located as follows:

(A) *On airplanes*—On the lower surface of the lower left wing and the upper surface of the upper right wing, the top of the letters or figures to be toward the leading edge, the height to be at least four-fifths of the mean chord; provided, however, that in the event four-fifths of the mean chord is more than 30 inches, the height of the letters and figures need not be more but shall not be less than 30 inches. If the lower left plane is less than one-half the span of the upper left plane, the letters or figures thus described shall be on the under surface of the upper left plane, as far to the left as is possible. In the case of a monoplane the mark shall be displayed on the lower surface of the left wing and the upper surface of the right wing in the manner thus described. The marks shall also appear on both sides of the rudder, of size as large as the surface will permit, leaving a margin of at least 2 inches.

(B) *On airships*—On both sides near the maximum cross section and on the lower under surface of the nose, the height to be equal to at least one-twelfth of the circumference at the maximum transverse cross section of the airship, but it need not exceed 8 feet.

(C) *On balloons*—Twice, near the maximum horizontal circumference, as far as possible from one another, the height to be equal to at least one-twelfth of the circumference of the balloon, but it need not exceed 8 feet.

(D) The width of the letters and figures of all marks shall be at least two-thirds of the height, and the width of the stroke shall be at least one-sixth of the height. The letters and figures shall be painted in plain black type on a white background or in any color or any background, but there must be a strong contrast between the two. The letters and numbers must be uniform in shape and size. A space equal to at least one-half of the width of a letter shall be left between each figure or letter.

## Capt. Frank Hawks

(Continued from page 28)

Outstanding among these were flights from Detroit to New York, a distance of 640 miles, in 2 hours, 41 minutes, giving him an unofficial record for speed and distance; Philadelphia to New York, a distance of 90 miles in 20 minutes, averaging four-and-a-half miles a minute.

Apart from these speed operations, Hawks is distinguished as the first transcontinental glider pilot. Towed by an airplane, piloted by J. D. (Duke) Jernigin, another Texaco flier, Hawks maneuvered his glider from San Diego to New York in the spring of 1930, explaining that the long trip with its landings in a score of cities was a deliberately spectacular effort to rivet attention on gliding, a logical first step for the training of airmen.

Hawks is now aeronautical advisor for The Texas Company, under which his spectacular career was fostered, and holds a captain's commission in the air corps reserves.

After each of his flights, Hawks faces a stock question from newspapermen:

"What's next?"

And his stock answer is:

"I'd rather not say. Give me a chance to do it."

We'll see, however, we'll see.



# Model Airplane News

AND JUNIOR MECHANICS

Vol. IV No. 4

Published by Harold Hersey  
Edited by Capt. H. J. Loftus-Price

## In Our Next Issue

## CONTENTS

APRIL, 1931

|   |    |
|---|----|
| Airplane Enginess—What They Are, and Why<br>By Lieut. (jg) H. B. Miller | 4  |
| <i>Concluding the Discourse on Motive Power</i>                         |    |
| Special Course in Air Navigation<br>By Capt. L. S. Potter               | 7  |
| <i>Continuing this Absorbing Series</i>                                 |    |
| How to Build a Rotor Flying Model<br>By Prof. T. N. de Bobrovsky        | 9  |
| <i>A Revolutionary Type of Plane</i>                                    |    |
| Gliding and Soaring By Percival and Mat White                           | 16 |
| <i>More on this Thrilling Sport</i>                                     |    |
| The American Sky Cadets   | 19 |
| How to Build the Bowlus Sailplane<br>By Jesse Davidson                  | 21 |
| <i>A Great Soarer Scaled Down</i>                                       |    |
| The Mystery of the Silver Dart By Ray Creena                            | 25 |
| <i>All's Well that Ends—as Well as This</i>                             |    |
| America's Human Bullet  | 27 |
| <i>Capt. Frank Hawks and his Amazing Career</i>                         |    |
| All Aboard, Model Trainmen!<br>By Theodore Orchards                     | 29 |
| <i>A Trip to Miniature Railwayland</i>                                  |    |
| A Course in Airplane Designing By Ken Sinclair                          | 32 |
| <i>All About Propellers</i>   |    |
| Aviation Advisory Board   | 33 |
| <i>Air Traffic Regulation</i>   |    |
| "Tail Spinning" with a Pioneer  | 35 |

Those who are planning careers in the flying service of the government will be thrilled with an article appearing in the May issue of *Model Airplane News*. It is a one-day log of a flying sailor and was written by your favorite author, Lieut. H. B. Miller. He is engine instructor at the U. S. Naval Training Station at Pensacola, Florida, and ought to know!

◆◆◆◆◆

Speaking of careers—the life of the man who pilots a plane and at the same time writes signs in the skies must be an interesting one. You will read all about it and the men who are foremost in this exciting business in the article, "Sky Writing," in the same issue.

◆◆◆◆◆

As for models—Prof. T. N. de Bobrovsky has prepared two marvelous models for you. One is a convertible Mono-Biplane and as for the other, he won't even tell us! All he says is that it is a great surprise and when he says that, it's bound to be a peach. Watch for it!

The same issue will have more of the good old reliables—*Gliding and Soaring*, *Course in Air Navigation*, and *Designing Course*.

◆◆◆◆◆

### COMING!

A home wind-tunnel device is being prepared for the model maker who insists on exact workmanship. . . . Once again Capt. Leslie Potter, world famous aerial navigator, who has held your interest with his navigation course comes through with a series on aerial radio, in which he will teach you all there is to know on the subject. . . . Lieut. H. B. Miller is also rushing into the breach with a whole course in airplane engineering. . . . More about these later!

Don't forget—*Model Airplane News*, the wonder magazine of the air! On all newsstands March 23 and only 15c a copy!

Published Monthly by GOOD STORY MAGAZINE COMPANY, INC., Myrick Bldg., Springfield, Mass.  
Editorial and General Offices, 25 West 43rd Street, New York City

Harold Hersey, President Pauline Sandberg, Treasurer Frank Moran, Secretary  
J. W. LeBaron, Advertising Manager, Graybar Building, 420 Lexington Ave., New York, N. Y.

Entered as second-class matter June 5, 1929, at the Post Office at Dunellen, N. J., under the Act of March 3, 1879.  
Application for transfer to Springfield, Mass., pending.

Additional Entry at New York, N. Y.

Copyright, 1931, by GOOD STORY MAGAZINE COMPANY, INC.

Price 15c a copy in U. S. and in Canada. Subscription price \$1.50 a year in the United States and its possessions; also Canada, Cuba, Mexico and Panama.

All other countries \$2.00 per year.

Chicago Advertising Office: 333 North Michigan Ave., C. H. Shattuck, Manager.

London Agents: Atlas Publishing & Distributing Co., Ltd., 18 Bride Lane, London, E. C.

Contributors are especially advised to be sure to retain copies of their contributions, otherwise they are taking unnecessary risk. Every possible effort will be made in our organization to return unavailable manuscripts, photographs and drawings, (if accompanied by postage), but we will not be responsible for any loss of such matter contributed.



A SENSATIONAL ANNOUNCEMENT by America's Leading Model Aircraft Designers



COL. RICKENBACKER.  
AMERICA'S ACE OF ACES

COLONEL  
E. V. "Eddie"  
Rickenbacker's  
**SPAD**  
(1918)

Now you can build a 3/4" scale flying model of Colonel Edward V. Rickenbacker's famous war-time Spad, reputedly *the most efficient war plane the Allies had*, and used in the greatest numbers, mostly by U. S. and France when the war ended. This Cleveland-Designed model with a span of 19 3/4" and length of 15 1/4" is colored just like its prototype used by Capt. "Eddie" Rickenbacker during the World War. It has yellow wings and tail surfaces, and a green fuselage. Wing circles, stars for the wheels and the Hat-in-the-Ring insignia are supplied in every kit. This history-making model is one of the latest of the remarkable Cleveland-Designed, easy-to-build kits—famed for their long distance flights. Complete kit includes everything necessary. Order Kit CB-2, only \$4.00 postfree. And remember, every Cleveland-Designed Kit contains full size, super-detailed drawings.

**FOKKER D-7 BIPLANE**

(German, 1918)

This daring German plane was quite generally acknowledged by pilots as being the most efficient fighting plane in the air at the time the Armistice was signed in 1918. Span of the realistic Cleveland-Designed model is 22"; length, 16 3/4". As dark green was a characteristic color of the Fokker D-7, we have given our model dark green wings and tail surfaces, and orange fuselage and struts. Maltese crosses and everything needed are included in the kit. Order Kit CB-3, only \$4.00 postfree.

**NIEUPOORT SCOUT**

(French, 1917)



This remarkable little machine was loved by all airmen as the most efficient fighting plane of its time. Flown by practically all famous French pilots and by many of the English and American birdmen. The Cleveland-Designed

model has a span of 20-1/4" and length of 13", brilliantly colored yellow wings and tail, and black fuselage and struts. In every way the model is a real beauty! This kit, like all Cleveland-Designed kits, is complete—nothing else needed. Order Kit CB-4, only \$1.00 postfree.

**ALBATROSS C-3**

(German, 1917)



This famous German "Spad," as it was nicknamed, was one of the most beautiful little streamliner jobs and the "hell-diver" of its time. The Cleveland-Designed model is colored with orange for the wings, and the fuselage and

tail and struts are colored light blue. It has a span of 22", and a length of 18-3/4". Kit comes complete with everything needed. Order Kit CB-5, only \$1.00 postfree.

**BOEING FIGHTER**

(U. S., 1931)



Every aircraft engineer will want to build one of these sensational present-day fighting planes to stand alongside the famous fighters of 1917-1918. You will see the change in aircraft design practice. This Cleveland-Designed

model has a 22-1/4" span, and 11-1/2" length. Brilliant yellow and olive drab coloring. Flies beautifully and will fly well over 400 feet when properly constructed. Kit comes complete with everything. Order Kit CB-1, only \$4.00 postfree.

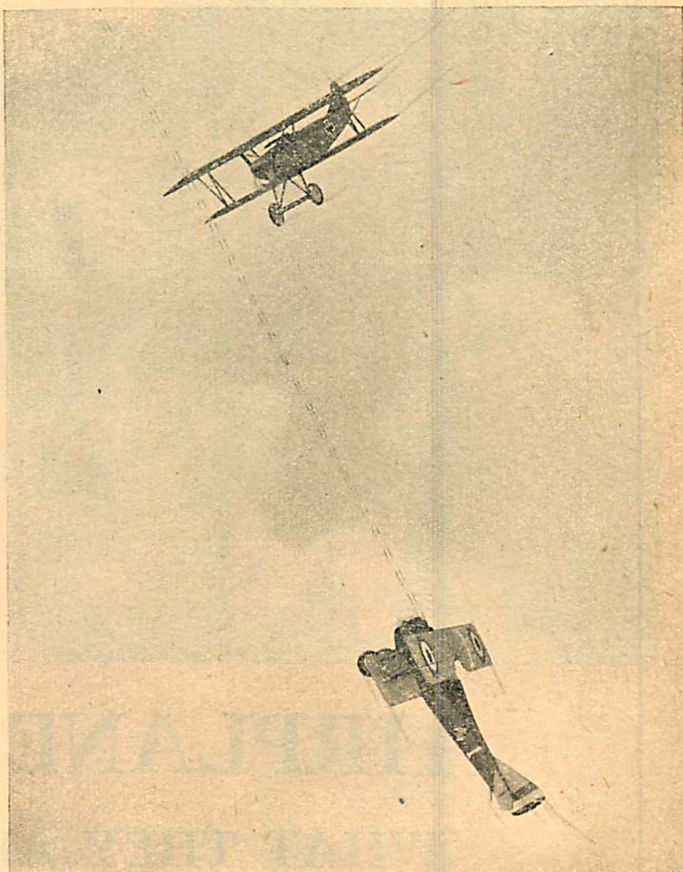

"I was in exactly the right position to meet his coming and at the proper moment I pulled my machine straight up on her tail, trained my sights along the line of his dive and began firing. My bullets cut a straight streak of fire up and down his path. . . . He fell away and dropped, but did not burst into flames."

(From Col. Rickenbacker's "Fighting the Flying Circus," Published by Fred'k A. Stokes Co., \$2.00 per copy.)

NOTE: The above picture was posed by the Cleveland-Designed models of Col. Rickenbacker's Spad and the German Fokker D-7.

**All These War Models**

the result of many months research work, are designed as closely to scale as it is possible to get them because of the meager reports available on these machines. All models fly beautifully, and in our test flights during the winter have flown no less than 200 feet.

**Send for Notebook-Catalog NOW**

which lists 17 other models in colors and their description. Large variety of supplies. As yet the catalog does not list these four World War machines, but inserts for them will be mailed later to all catalog purchasers. Be sure to send 25c for your Notebook-Catalog. (NO FREE COPIES.) Ask your dealer for Cleveland-Designed models, and tell him you want to join the new N.A.M.E. Suggestion: *Keep this page for your catalog!*

Cleveland Model & Supply Co., Cleveland, Ohio.

**Free!** COL. RICKENBACKER'S Famous Book given free with an order for any three of these War Planes at one time. Offer granted only direct—not through our dealers. Expires midnight April 30, 1931.

CLEVELAND MODEL AND SUPPLY CO.

1866N West 57th St., Cleveland, O.

( ) Rush free copy of "Fighting the Flying Circus" (regularly \$2), and Kits CB-....., CB-....., CB-....., for which is enclosed \$12 (check, M.O.)

( ) Rush Kit CB-..... for which I enclose \$1.00 (check, M.O.)

( ) Rush Notebook-Catalog for which I enclose 25c.

NAME..... Age.....

ADDRESS..... CITY..... STATE.....

No boy who has ever built a Cleveland designed model can fail to see its great superiority in every way. Expertly designed, easy to build, *more for the money.*



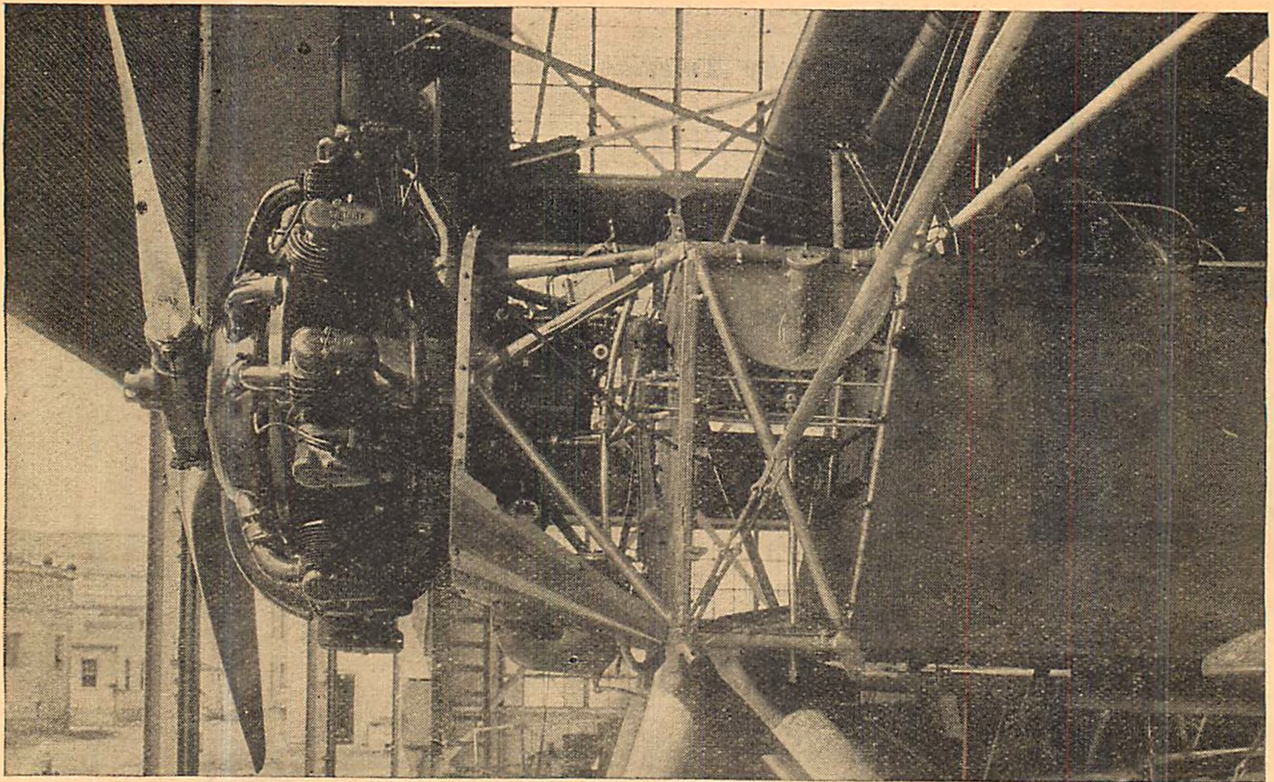

# AIRPLANE ENGINES

## WHAT THEY ARE—AND WHY!

**T**HE cooling system is divided in two separate types. The first of these is:

*Water Cooled Engines:* The first engines used in airplanes were of this type. We have seen how they carried aviation along during the critical period of the World War. It seems impossible when we recall that the Wrights made the first flight in a plane weighing 750 pounds with a twelve horsepower engine, and further, that the propeller delivered only about two-thirds of the power. Their engine weighed a little more than fourteen pounds per horsepower.

*Types:* The Wrights' first engine had horizontal cylinders. Next came the successful vertical engine. As more cylinders were added, they were arranged in banks. Two banks were termed a Vee engine. Three banks were attained in time and were called a W engine. Lieutenant Al Williams hooked two Packard engines together on the same crankshaft and evolved an X engine of 1,200 horsepower. Until the last Schneider Cup Races it remained the most powerful airplane engine ever built.

The advantages of the

By  
**LT. (jg) H. B. MILLER**  
(PART 2)

post-war water cooled engines can be summed up as follows:

1. More power for weight
2. Greater reliability
3. Less frontal area and resulting

resistance

4. Regulation of heat by means of shutters, etc.
5. Greater visibility

These advantages have been swept away one by one by the air-cooled engine and only two remain—that of visibility and head resistance. It is not impossible that these factors will eventually be successfully countered by the air-cooled engine.

*Weight:* As aviation progressed, the weight of the water-cooled engine went down rapidly; so quickly, indeed, that when the air-cooled engine first made its appearance it could not stand the comparison successfully. Practically all the early post-war developing thus took place on the water-cooled engines and it soon became a comparatively refined product.

The water-cooled engine was secure in its position as the best type of power plant available. The production of

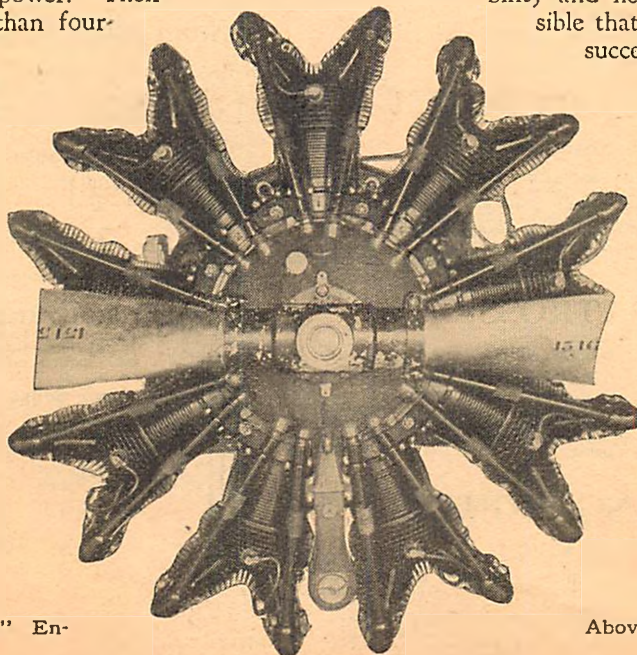

Right—A Pratt-Whitney "Wasp" Engine, 450 h.p.

Above—How accessories are faired into the fuselage



the wartime Liberty engine clinched its case. The weight per horsepower of this engine was 2.5 pounds, a remarkable performance for that time.

**Reliability:** Army statistics gathered some years after the war showed that from sixty to seventy per cent of all forced landings were being caused by cooling difficulties. A number of things were involved, such as radiators, plumbing, water pumps, water jackets, or lack of water. At that, with all the forced landings caused by water-cooled engines, they were able to claim more reliability than the then-prevalent air-cooled engine.

The water-cooled system did maintain a more constant temperature. For instance, in a steep dive of 10,000 feet or so, an engine will cool off considerably and may fail to operate properly when the plane is leveled off. Shutters were provided for the radiators so that the engine could be kept warm. Even in a glide for a landing a warm engine is desirable. The shutter system provided this means of reliability.

Water-cooled engines frequently are not able to operate under conditions of severe heat. For instance, the atmosphere above the vicinity of San Diego is at times extremely hot. This is called a "heat inversion." At times it is impossible to climb a water-cooled fighter up through this warm stratum. No air-cooled job has ever had the slightest difficulty in pulling up through this hot belt.

Again, when operating in hot weather at a high altitude where the density of the air allows the water to boil easily, it is possible to lose a great deal of radiator water by evaporation. This may result in a further lack of cooling and consequently disastrous results.

The speed obtainable from a plane mounting a water-cooled engine generally is greater than the same plane with an air-cooled engine. This is because of the small frontal area of the water-cooled job. It is long and well streamlined into the fuselage. The head resistance is comparatively little. This naturally gives more speed.

In addition to the natural small

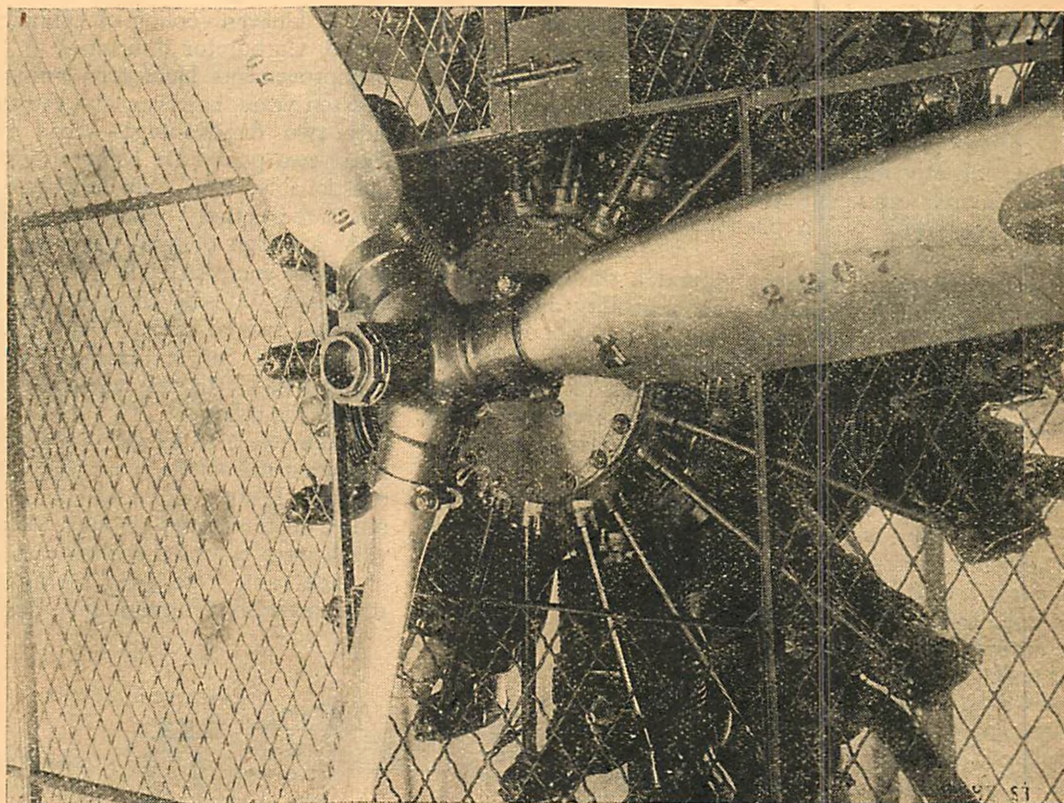

**Lieut. Miller is Instructor in the Engine Section of the Ground School at the Naval Air Station, Pensacola, Fla. Formerly he was Engineering Officer of VF Squadron Two-B Battle Fleet. What better authority could you wish to instruct you on such technical matters as airplane engines?**

head resistance, wing radiators are used on racing planes for cooling the engines. These radiators are small corrugations extending from the leading to the trailing edge of the wing. The water is drawn through these small tubes where it is cooled by the air stream. This eliminates the familiar bulky radiator. It cuts down still further the head resistance and

gives even greater speed, but, the wing radiators are too fragile to be used on average commercial planes.

Visibility is an inherent quality possessed by the water-cooled engine. So far the air-cooled job has

had to take a back seat in this important factor. The water-cooled power plant is long and narrow while the air-cooled engine is short and wide. This is particularly noticeable in

airplane carrier landings where the pilot tries to see between the cylinders—and can not. Visibility is equally important to the commercial pilot who must see where he is landing on a field probably already overcrowded.

The propeller is attached to the hub which is a projection of the engine crankshaft. Since the propeller must clear the ground or the pontoon, the engine is raised. This places it in a position that partially obstructs the pilot's vision. In order to increase visibility still further in some installations, the engine has been inverted. That is, turned upside down and so installed in the plane.

This system operates satisfactorily and gives excellent visibility.

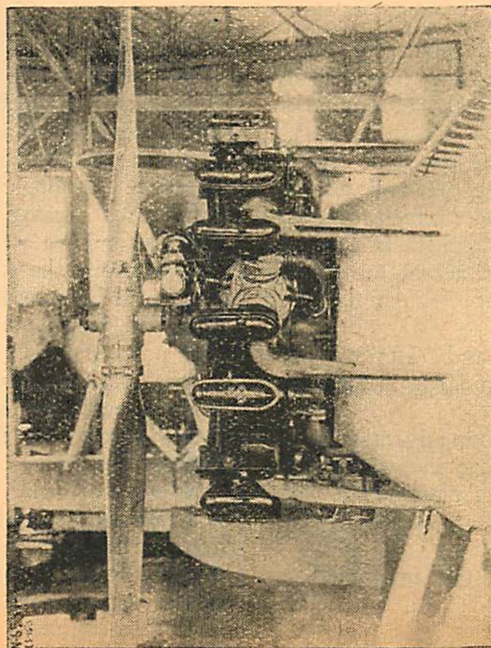

Right—Showing the resistance offered by an air-cooled engine

Above—An engine test stand, showing how test is conducted



True, more oil gets into the cylinders and fouls the spark plugs more easily. The oil is drained out of the crank case by sumps placed between the banks of cylinders.

**Air-Cooled Engines:** One of the first air-cooled aviation engines produced was the two-cylinder Detroit Aero engine. Shortly afterwards, in 1909, the French Gnome rotary engine was manufactured at a weight of 3.9 per horsepower. This was a phenomenal power-weight ratio for the time.

The rotary engine revolves around a stationary crankshaft. The Gnome possessed fair reliability and it gave fair service on the Western Front but it labored under various difficulties. Gasoline vapor was led to the cylinders through the crank case. This close contact of gasoline and lubricating oil broke down the lubricating properties of the oil. Thus, it was difficult to properly lubricate this type of engine.

Stresses set up by the revolving of the cylinders were enormous. Constant inspection was necessary. Ignition was difficult because the entrance of lubricating oil into the cylinders fouled the spark plugs. In addition, the revolving engines set up a terrific centrifugal force which gave an airplane peculiar unstable characteristics. The rotary engine was displaced during the War and is not used any more.

The radial air-cooled engine is the familiar stationary type which is now so popular. It began life as a two-cylinder job, as we have seen. Charles Lawrance developed a three-cylinder Lawrance engine as early as 1916. Shortly after the War he constructed a nine-cylinder job. At this time the

Navy was seeking a light-weight power plant for use on battleship and carrier-planes. Both of these types demanded a slow landing speed. This new make of engine interested the Bureau of Aeronautics.

With their aid Lawrance developed the nine-cylinder model further. It was designated the J-1 and was the forerunner of the present Wright J series which is now so universally used. Thanks to sufficient contracts from the Army and Navy Departments and to actual tests under service conditions, the J-1 engine went through its growing pains successfully.

The Pratt and Whitney "Wasp" and "Hornet" have since come to be acknowledged as standards in large displacement design and construction.

The air-cooled engine possessed but one advantage in the beginning. That was a slight advantage in weight. The disadvantages, however, were many. Among them were:

1. Greater head resistance
2. Poor visibility
3. Oil in bottom cylinders resulting in fouled spark plugs
4. Cooling off during dives

5. Uneven cooling of cylinders

6. Carburetor difficulties

Improvements have been brought about rapidly in the past ten years, however, and the air-cooled engine possesses only two disadvantages—head resistance and visibility. These two points are being attacked by designers and unquestionably, it is only a matter of time until they are eliminated entirely. The two problems are inseparable.

As a matter of fact, the advantages of this type of engine have increased. It has stepped in and taken several advantages by staggering its six cylinders, thus reducing the total frontal area. The Cirrus four cylinder vertical in line is a further example of air-cooling which gives added speed. In this case, the cylinders are placed one behind the other.

In an effort to eliminate the forced landings caused by plumbing difficulties, the Army Air Service attempted to cool the Liberty engine by air. Suitable baffles were installed to direct the air currents around the cylinders, on which were mounted cooling fins. The first four cylinders of each bank were satisfactorily cooled, but the last two rows invariably burned up. The task was at last given up as impracticable.

The air-cooled job has swept ahead on the score of reliability, also. This is due primarily to the elimination of the water system which offered a constant threat of forced landings. Recent trans-oceanic flights have proved conclusively the reliability of this type of engine. Endurance records have gone even higher. Had water-cooled engines been used on these flights, many more contacts with the re-

fueling plane would have been necessary to take on water.

It is questionable whether a radiator would have withstood such a long period of vibration. The water pump would have been an added mechanism to worry about. Water jackets are apt to crystallize and crack from constant vibration. Rubber hose connections deteriorate and rot away, thus causing leaks. Even the best radiators break down after hard service.

In wartime the radiator and water jackets need only to be pierced by a bullet to place the ship out of commission. Thus, the water-cooled engine is inherently weak for military purposes.

In a crash the hot water jackets add a menace to an already potent fire hazard. With gasoline all about and fumes permeating throughout the hot engine, a fire is a distinct possibility.

When operating in freezing temperatures, the radiator is a nuisance, indeed. It must be drained after operations are over for the day and must be filled with hot water before flying can begin. Flights in both the Arctic and Antarctic regions have been carried on for the most part with air-cooled engines.

(Continued on page 44.)

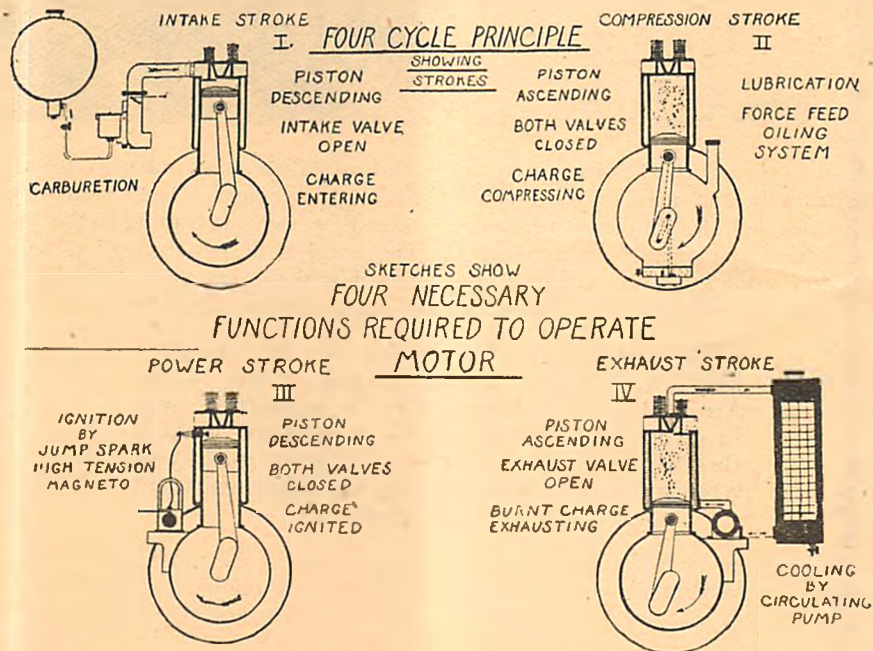



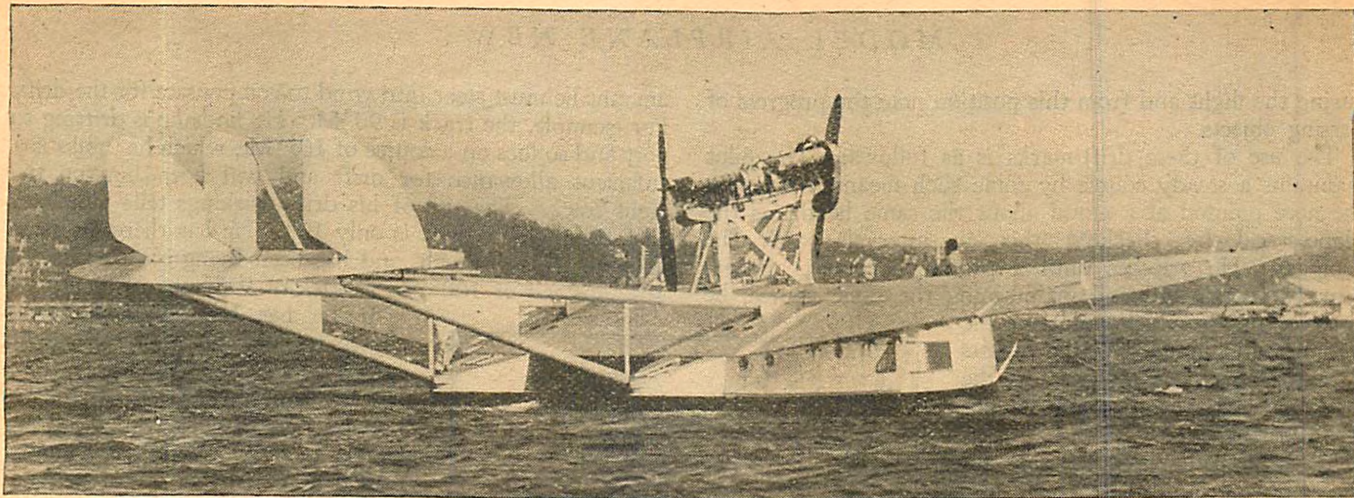

A Savoia-Marchetti S-55

## Special Course in **AIR NAVIGATION**

By  
**CAPT. L. S. POTTER**

*I*N this series of articles, the author has endeavored to set out as clearly as possible, and in as simple words as possible, the art of navigation in the air.

Your interest in these will depend on your interest in flying, and whether you will consider yourself a pilot when you have learned to take a plane off the ground and bring it down again without breaking anything.

To those who do, these articles will be valueless, but to those who aspire to be more than fair weather pilots, to be able to fly from place to place without sole recourse to roads and railways, to be able to fly above the clouds with safety if they are too low to admit of safe flying beneath them, an intelligent interest in these articles will be of incalculable value.

If some of the points seem too elementary, do not pass them by, there is a reason for their inclusion; if some points do not seem clear, be patient, you will generally find some information further on that will clear them up as you proceed. Answer the questions at the end of each article and wait for their solutions in the next issue, and should you find any points requiring further explanation, send a letter with a stamped addressed envelope to the editor setting out your problems and a reply will be sent you explaining the points raised.

THE EDITOR.

**W**E HAVE been dealing with various methods of finding windspeed and direction. Most of these were concerned with the direct ascertaining of these facts, but as you will know by now, the knowledge of the angle of drift or of the track is tantamount to the knowledge of the actual windspeed—the one can be easily gleaned from the other.

The finding of drift angles has hitherto been dealt with through the me-

dium of the drift indicator, and the value of this instrument in air navigation is again emphasized. Its absence, however, does not spell complete inability on the part of the pilot to ascertain his drift angle. Other methods exist, which though perhaps not so accurate, must of necessity be used in certain cases.

For the pilot who has to remain at the controls, for instance, while doing his navigating, the use of a drift indicator is difficult. It is hard to maintain a constant course and airspeed while gazing steadfastly down an eyepiece.

As a single seater pilot I have found the type of drift indicator secured underneath the fuselage the most satisfactory. A glass plate in the floor immediately in front of the pilot's seat allows him to view objects beneath which are passing along the drift wire without materially altering his position. The drift wire is secured immediately below the glass plate, and the instrument is operated by a handle let in through the floor just in front of the seat.

*Method 4.* In the absence of a drift indicator the use of drift lines painted on the wing proves a useful substitute, though these could obviously not be used with the type of plane where the pilot sits in front or below the main wing.

Lines are painted on the wings at different converging and diverging angles. On the port wing, for example, might be painted five or six drift lines diverging at angles of 5° to 25° or 30° from the leading to trailing edges, and on the starboard wings might be painted similar lines. In this way, both port and starboard drifts are accounted for.

An important point to remember is that when the lines are painted their extremities must be so placed that they are at their angles of 5°, 10°, 15°, etc., from the position normally occupied by the pilot's head. In this way he is enabled to sit naturally

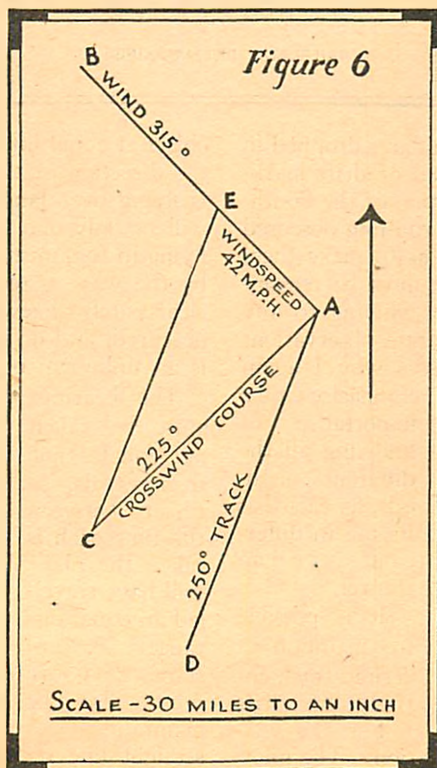



during the flight and from this position note the progress of passing objects.

The use of these drift-marks is as follows: The pilot maintains a steady course by some such means as keeping the nose pointed at a cloud about the same height as the plane, and by checking this at intervals with the compass. He watches until a prominent object appears directly ahead, and still maintaining the same course, he observes under which point on the leading or trailing edges the objects appear to pass. Reference to the markings will then give him his angle of drift.

With a little practice the approximate groundspeed can also be judged by the period that elapses while the object is being obscured by the wing. This period of time will obviously bear a different ratio to the groundspeed at different heights. The conditions to be observed in order to gain reasonably accurate results by this method are:

1. That the plane is maintained on a constant course.
2. That the pilot keeps his head in the correct position.
3. That the mean of several readings is taken.

In addition to drift lines being painted on the main wings, they may also be used with advantage on the tail-plane. See Figure 1.

These, of course, are of less value to a pilot than an observer; but for the latter, a more unobstructed view is obtainable. An experiment was made whereby a pilot might use drift markings on the tail plane by means of a mirror but this was not a success.

A similar operation is followed as has just been outlined. The plane is kept on a constant course and when the object is well astern, observation is made of the drift by noticing under which particular mark on the tail the object appears to pass. Over the sea flares may be dropped and tail bearings taken on these.

It is interesting to note, however, that this method (of taking tail bearings on flares dropped in the sea, but with a bearing compass instead of drift markings), was found of little use in the navigation of the Southern Cross on its Pacific flight. Heavy seas running obscured vision of the flares for such long periods as to make them almost valueless, and in this connection it must be remembered, too, that with a plane pitching or yawing to any extent, it would be impossible to get accurate observations of drift even with an instrument. This is why I again emphasize the

importance of knowing all the different methods, as each has its use in different circumstances.

It is possible to maintain a desired track entirely by drift observation. The pilot, knowing the bearing to his destination, decides on the

amount he must steer into wind to compensate for the drift. For example, the track is  $90^{\circ}$ M. He finds he is drifting to port and so flies on a course of  $105^{\circ}$ M., which he thinks is a sufficient allowance for drift and will keep him on the right track. The use of his drift markings tells him later that his angle of drift is only  $10^{\circ}$ . He has therefore been allowing  $5^{\circ}$  too much, and has been flying on a course of  $105^{\circ}$  instead of  $100^{\circ}$ , or a track of  $95^{\circ}$  instead of  $90^{\circ}$ .

If he has been following this course for half an hour, he should now fly on  $95^{\circ}$ — $5^{\circ}$  too little—for a half an hour to compensate for his previous error. Then the correct course of  $100^{\circ}$  could be resumed provided no further change in the drift has been observed in the interim. This, however, is a haphazard

method and would not be used in flights of any distance or importance. One degree error in your compass course will take you a mile off your correct track for every sixty miles you fly. There is no place for guessing in scientific navigation.

**Determining the Track.** The methods of obtaining fixes or pin-points and connecting them by lines drawn on a map which give you your track and groundspeed, have already been explained. In Figure II a pilot flies directly over a prominent object and subsequently maintains steadily the same course. When the object is well astern the navigator will take a bearing on it with a bearing plate or bearing compass, and this bearing will be the reciprocal of the track being made good.

In Figure II, he finds that object A has a bearing of  $257^{\circ}$  from the plane. The track he has been making good while steering a course of  $117^{\circ}$  is  $77^{\circ}$ , the reciprocal of  $257^{\circ}$  ( $257^{\circ}-180^{\circ}$ ). This example has been emphasized, you are hardly likely to meet with a  $40^{\circ}$  angle of drift.

**Method 5.** This is a method which normally should not be used. It is a system of taking bearings on a single

object at equal intervals of time, and ascertaining therefrom the direction of the track. It may happen that when one is flying over land or sea in conditions such as fog, there will be only one unrecognized object visible. Often when flying in fog, mist or sandstorm, neither of which condition, by the way, is recommended for aviation, there will be a clear patch somewhere, although everything else around is obscured, and on some object in this clear patch, even if it is an unknown object, bearings may be taken.

The bearings must be taken at equal time intervals, so that between the time each is taken the plane will have travelled an equal distance. A constant course must also be maintained. A straight line representing north may (Continued on page 39)

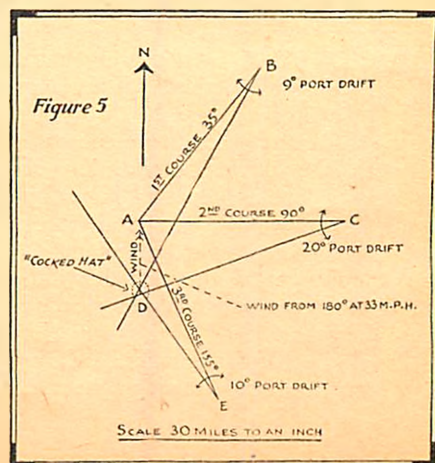
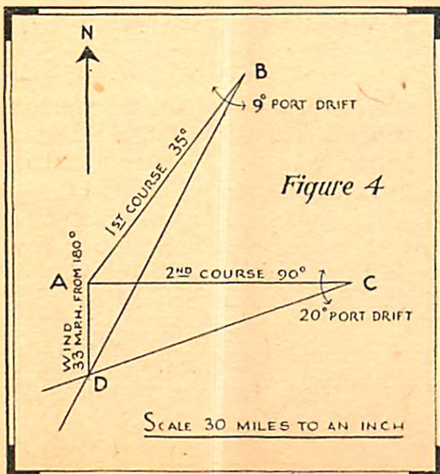
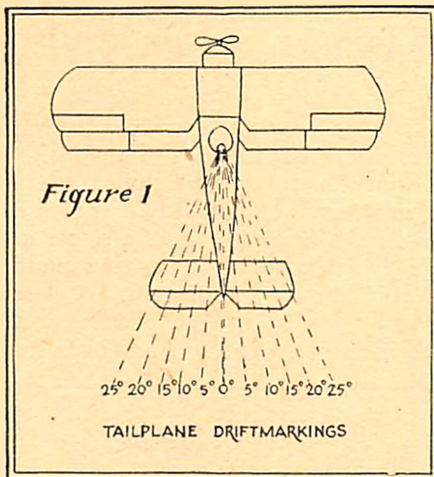
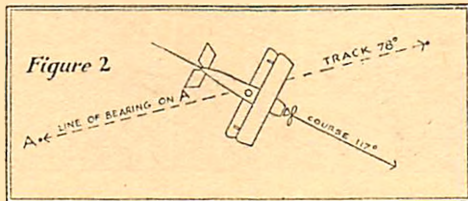



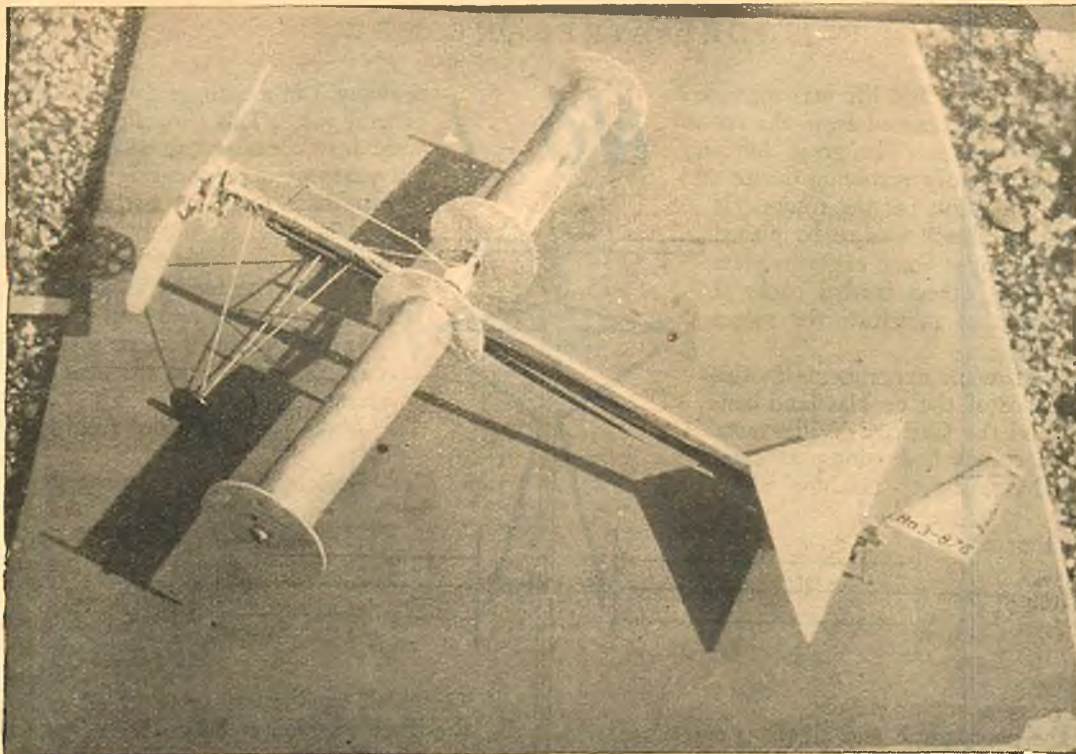

## How to Build a Rotor Flying Model

**C**ONTINUING the policy of providing something novel and timely for the model airplane enthusiasts, Model Airplane News presents the latest in revolutionary ideas concerning airplanes. It is nothing less than plans for a flying model of the Rotor plane, which created quite a furore during secret tests at Mamaroneck, L. I. Naturally, the model presented herewith is slightly modified for purposes of making it fly.

The designer and builder of the model is known to you all as the designer of the Curtiss-Bleeker helicopter and the helicoplane (autogyro), both of which, as you know, were eminently successful models. He is Prof. T. N. de Bobrovsky, one of the outstanding aerodynamic experts in the country.

Let's see what Prof. de Bobrovsky has to say about the model and its construction.

Examine the photograph carefully, he says, and you will note that in effect it resembles an ordinary stick model except that the wings are cylindrical in shape. These are the rotors. First let's get a clear idea of what a rotor is. The rotor is a cylinder, or cone, of varying length. The side plates, shown on the model, do not form a part of the rotor. They are added merely to create efficiency. They correspond to the vertical end plates which were attached to the Burnelli monoplane which was entered in the Guggenheim Safety Plane tests.

Readers acquainted with Ken

Sinclair's famous "Course in Airplane Designing" will have learnt from that that a cylinder moved forward with its axis perpendicular to the line of motion develops extraordinary drag.

It always has been emphasized in building models (and, naturally, in real planes) not to use round struts but to streamline them in order to reduce drag.

### Presenting this REVOLUTIONARY Airplane in MINIATURE

A German physicist, Henrick Gustav Magnus, in 1853 discovered that if a cylinder as described above revolves about its axis while moving forward, it produces an entirely different effect from a cylinder not revolving. In the front of the cylinder the air pressure increases and on the other side the vacuum becomes larger.

Seventy years after the death of Magnus, another German engineer, Dr. Anton Flettner, employed the Magnus theory to a ship with much success. By means of small motors he started vertical cylinders revolving and then left the rest to the wind. The Flettner ships, which might be classified as sailing vessels, achieved good results; one of them crossing the Atlantic in 1926 with a cargo of stone. This was followed by research work and experiments in the British National Physics Laboratory, the German Gottingen Institute, and other seats of aerodynamic investigation.

I first started experimenting with rotor type models in 1925

By  
**Prof. T. N. de Bobrovsky**



and discovered from tests that lift was increased and better results were obtained from the rotors than from ordinary wings. The great difficulty was to design a satisfactory revolving device and to find the proper location for the rotors. It was obvious that the rotor was to be placed somewhere in the wing. Some experimenters placed it at the edge, others further back. I think I was the first to substitute the rotors entirely for the wing.

Among the worthwhile experiments in this connection are those of the de Haviland concern of Britain and the Gerhard Wilke tests. Both of these machines had wings, as compared with the Mamaroneck machine which has only rotors.

Now for the model. It is easy to build and from it you will obtain a clear idea of the Magnus principles and also learn more about propellers.

First study the photograph and all plans carefully to become acquainted with the general idea of the model. Then make the stick from hard balsa, as shown in Fig. 2. Use the dimensions on the plans. Ambroid to its front and secure with thread the hanger (2) which has a hole  $1/16"$  in diameter for the axle. This is unusually strong for such a model but it is needed since the axle is under the stress of new and hitherto untried forces

Make a cutout on the stick  $7/8"$  from the front, as shown in drawing. This is the spot to which you must ambroid the wing-supporting device (5). To the end of the stick fasten the combined hook-tailskid (3). After this make the rudder holder (4) of soft balsa and ambroid it to the stick, as shown in drawing.

Bore a hole  $1/16"$  in diameter, as shown in drawing, and saw from  $3/32"$  thick cedar plywood piece 5. From  $1/40"$  cedar plywood cut two of pieces 6 and 7 and ambroid them together, as shown in drawing. When finished ambroid this device to the stick following closely drawing 2.

Now from bamboo (round), make two of piece 8, which are the bracings for the new wing-carrying device. The landing gear is made entirely of bamboo. Make two of pieces 9 and 10 and one of piece 11, and assemble them to make the landing gear, as shown in Fig. 1. Two celluloid wheels ( $1\frac{3}{8}"$ ) are used to complete the landing gear.

Next make the propeller. We will need an 8" diameter propeller for this model and I have marked the dimensions in

# No. 1

drawing 3 in a manner to make it serviceable for general use. This propeller and its proportions were first conceived in 1920 and resulted from ten years of experimenting with model airplane propellers. It is not designed for light models but is highly recommended when it is hard to decide what kind of propeller to use when the model is heavy. It is suitable both for tractors and pushers.

In the present instance we are dealing with a special model and the bent wood propellers are not suitable.

Make your propeller from hard or medium balsa.

Before fastening the propeller to the model, make a pulley from  $7/16"$  diameter harder round wood, following the sketches of pieces 13 and 12.

Make two pieces of 12 which can be cut from  $1/40"$  cedar. Ambroid the three together to form the pulley, which in turn is ambroid to the rear of the propeller, as shown in drawing.

Put a washer between the pulley and the hanger M (2), though if obtainable a ball bearing is more suitable and should weigh .035 of an ounce. The rubber power consists of six or eight flat rubber bands,  $3/16"$  thick.

Next make the elevator, following closely the details in drawing 4, particularly as regards the wood pieces B and C, which are  $3/32"$  thick. When the elevator is completed cover it with Jap tissue and attach it to the stick. Keep in mind that the length of piece B is always equal to the diameter of the propeller.

The rudder is also shown in drawing 4 full-size. One advantage of this rudder is that it does not cause the model to dive or side-slip when in a turn.

Piece E is  $1/16"$  thick round wood. The rest of the rudder is balsa. Cover both sides and fix it at point

4 in such manner that it is moveable. The model is now ready with the exception of the rotors, and in its present state without the rubber should weigh .528 of an ounce.

Our next job is the construction of the rotors. From a piece of good balsa ( $1/32"$ ) cut two of piece

16 as shown in drawing 5. See that the grain of the balsa runs in the direction indicated in the drawing. Next get a tube or rod  $1\frac{3}{8}"$  in diameter and prepare for use two pieces of adhesive tape 8"

(Continued on page 15)

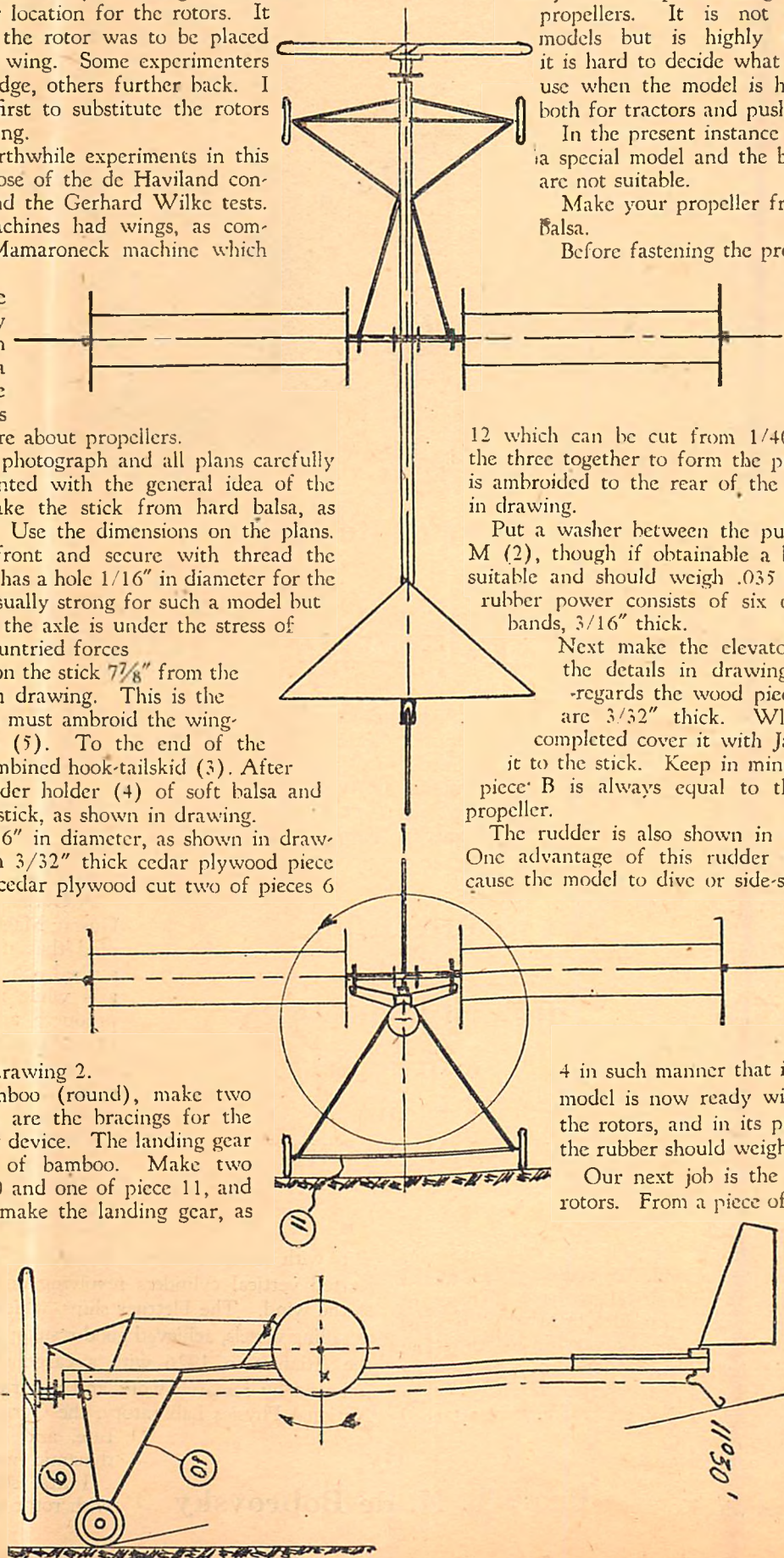



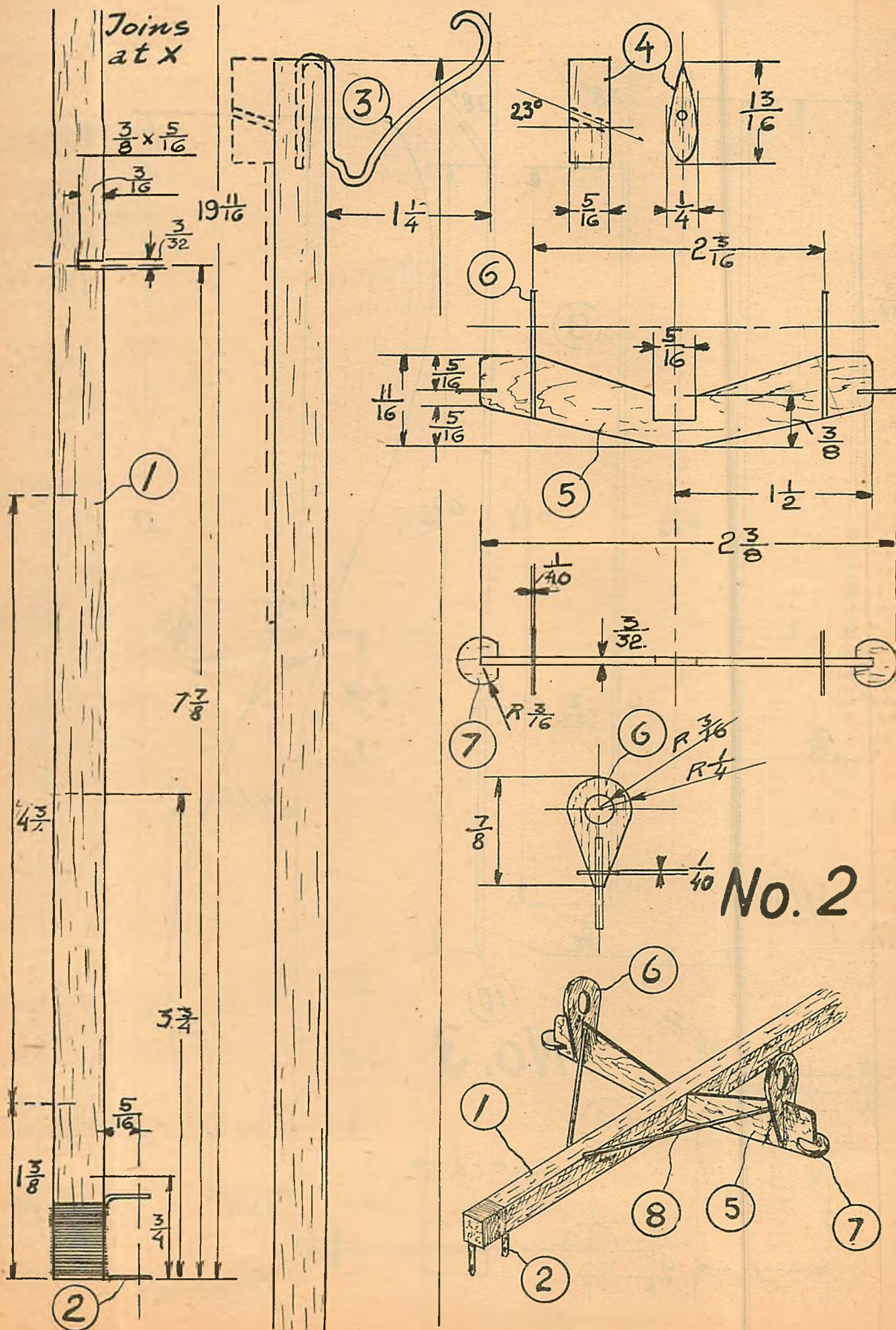



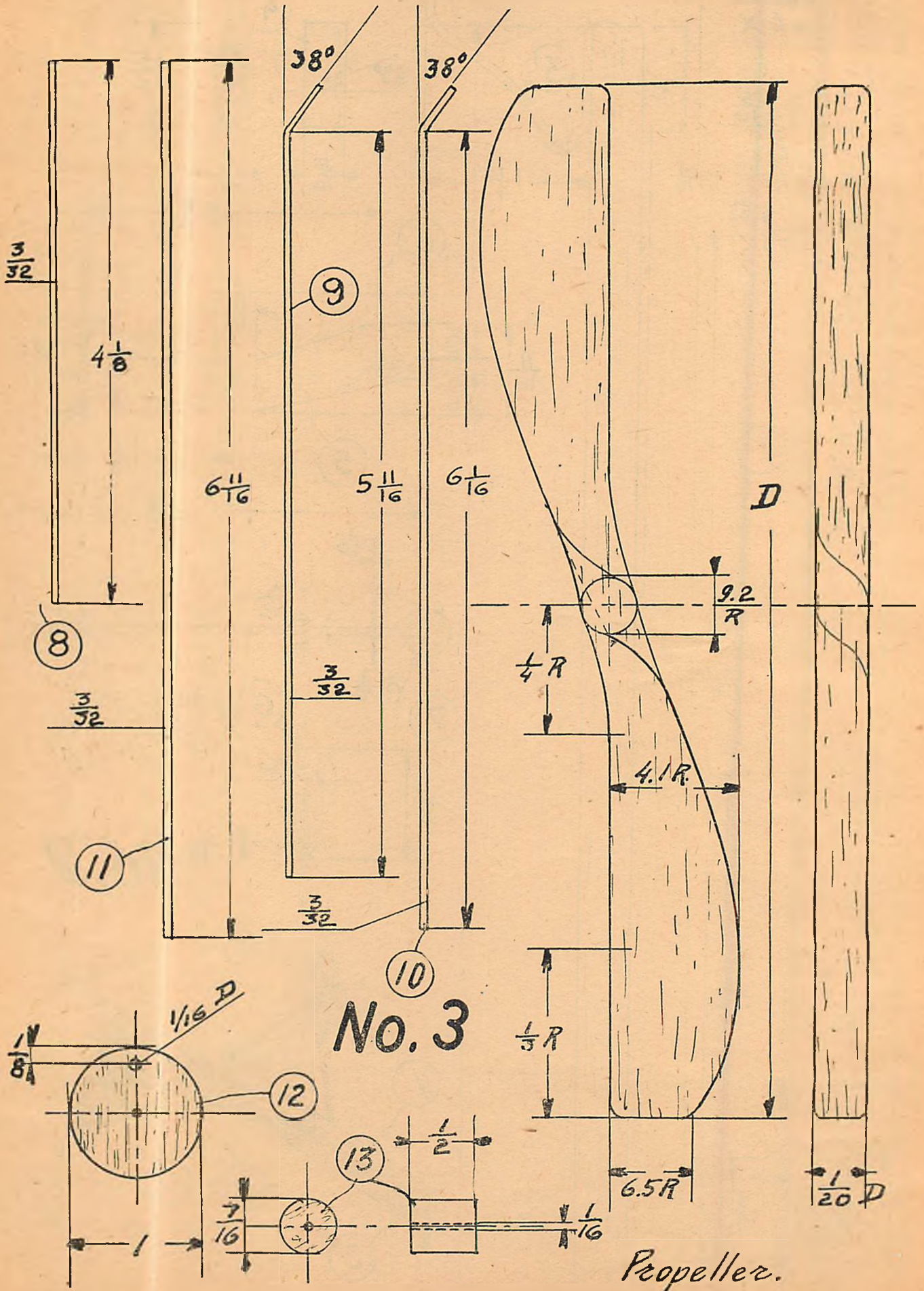



No. 4

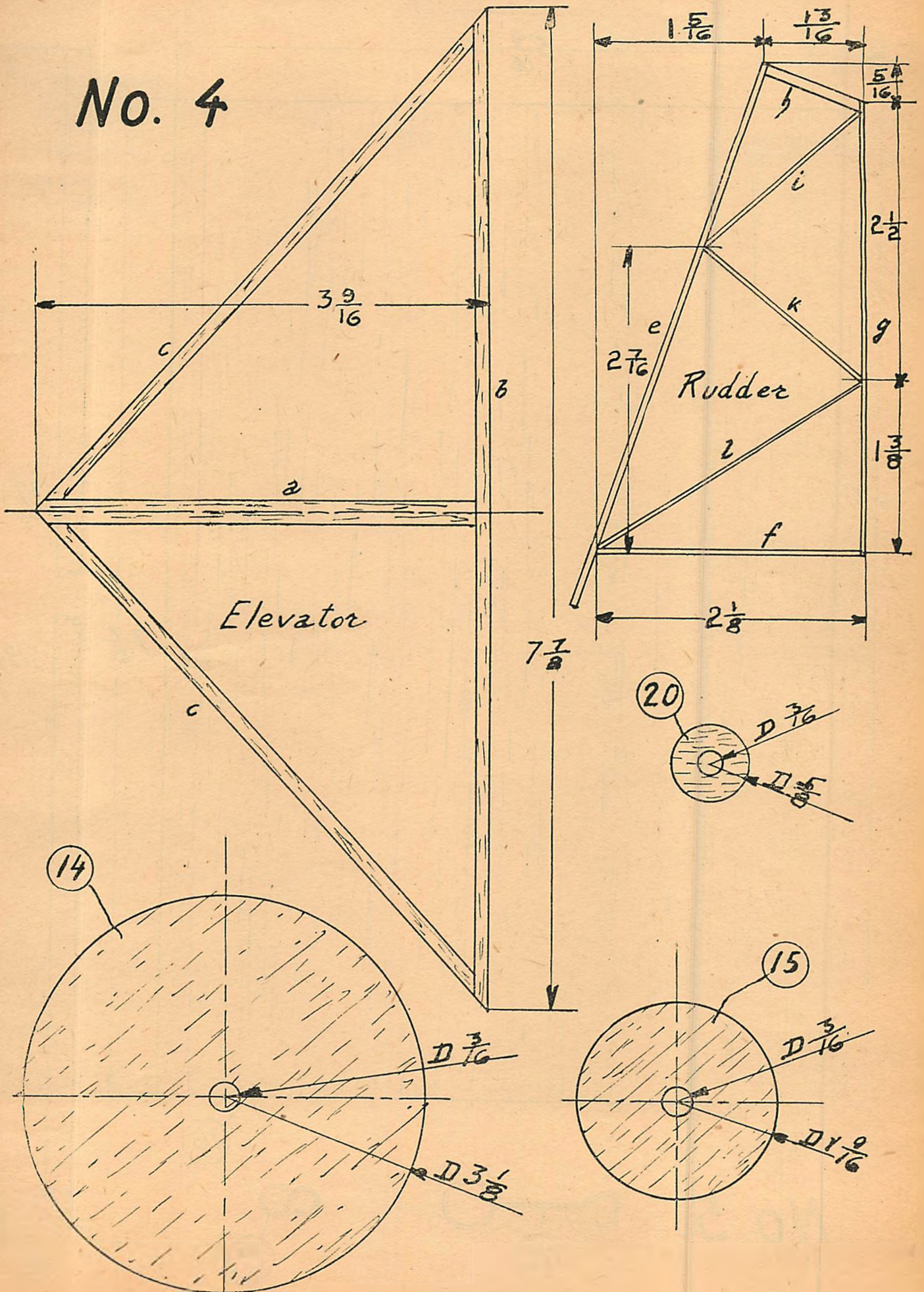



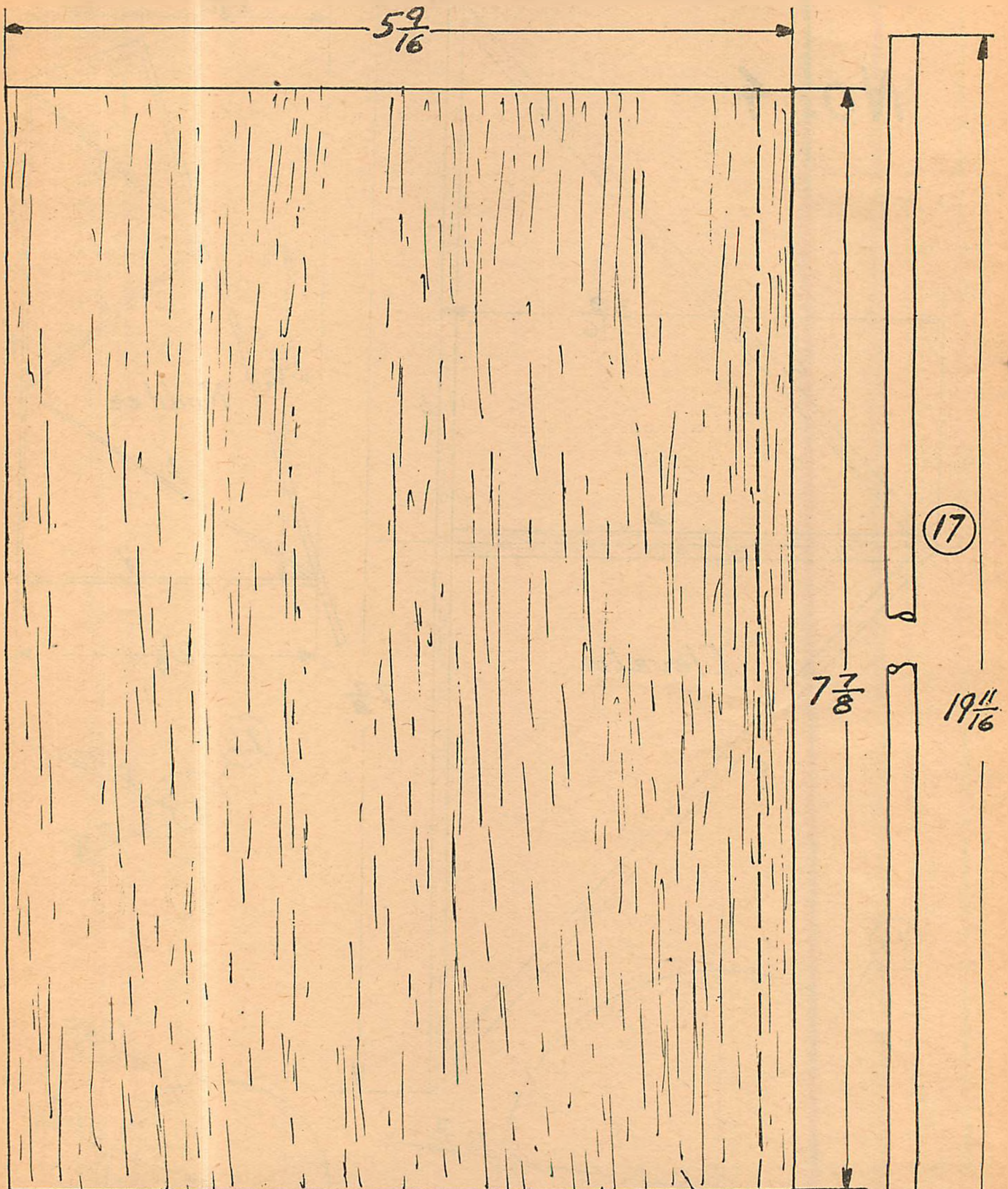

No. 5

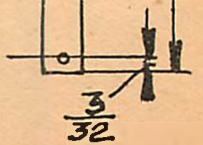
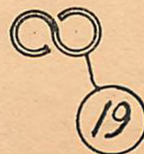
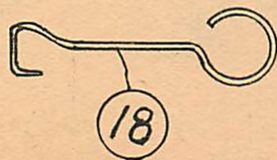



# The Rotor Model

(Continued from page 10)

around the tube or rod as shown in drawing 6. Ambroid the two touching ends of the balsa and secure it with the adhesive tape. The dry dope hardens and the balsa then takes on the shape of the tube. Remove it from the tube and the rotor is ready. Make two of these.

Next make the rod shown in drawing 5. It is  $19 \cdot 11/16$ " long and  $3/16$ " in diameter. Then from balsa make two each of pieces 14, 15 and 20. These are shown in drawing 4. Pieces 14 and 20 are made of  $1/16$ " and piece 15 of  $1/4$ " balsa.

Now comes the assembly of the rotors. First put piece 17 through the hole of piece 6. Then pull on the two round plates (20) and arrange piece 17 so that the hole of 6 is exactly in the middle. Next ambroid the two 20 pieces on the rod, as shown in drawing.

Fix pieces 14 and 15 as shown in drawing. Piece 15 fits in the edge of the rotors and prevents deformation. The outer ends of the rotors are to be handled the same way, using pieces 14 and 15. Fix hook 18, shown in drawing 5, in the hole made in piece 17. This is used for winding up the rope which operates the rotors.

Only the fittings are now left. They are all shown full-size in drawing 6 and should be constructed from the drawing and fixed in the places marked in the drawing.

Now to operating the rotors. The rope, or thread, to be exact, is fastened at one end to the pulley behind the propeller and at the other to the axle of the rotor. The thread winds off the axle if the propeller is in action. Ambroid a strong thread to the rotor axle (made of piece 17 and two of piece 20).

After drying wind on to the axle three to six yards of the thread and while winding it, the rotor should be turned opposite to the regular direction, which is indicated by an arrow on drawing 1. Tests can now be made. Be sure that the rotors turn easily. A little oil on the axle, wheels, etc., will help in this respect.

Wind up the rubber motor. Now hang hook 19, which is attached to the end of the thread, in the hole of the pulley (13-14). Let the propeller turn. The thread now should wind off the rotor pulley and on to the propeller pulley. This, of course, causes the rotors to revolve and the model to take off at great speed.

While in flight, of course, the propeller continually will lose power but the rotors, moved by inertia power, will bring the model down in a slow glide.

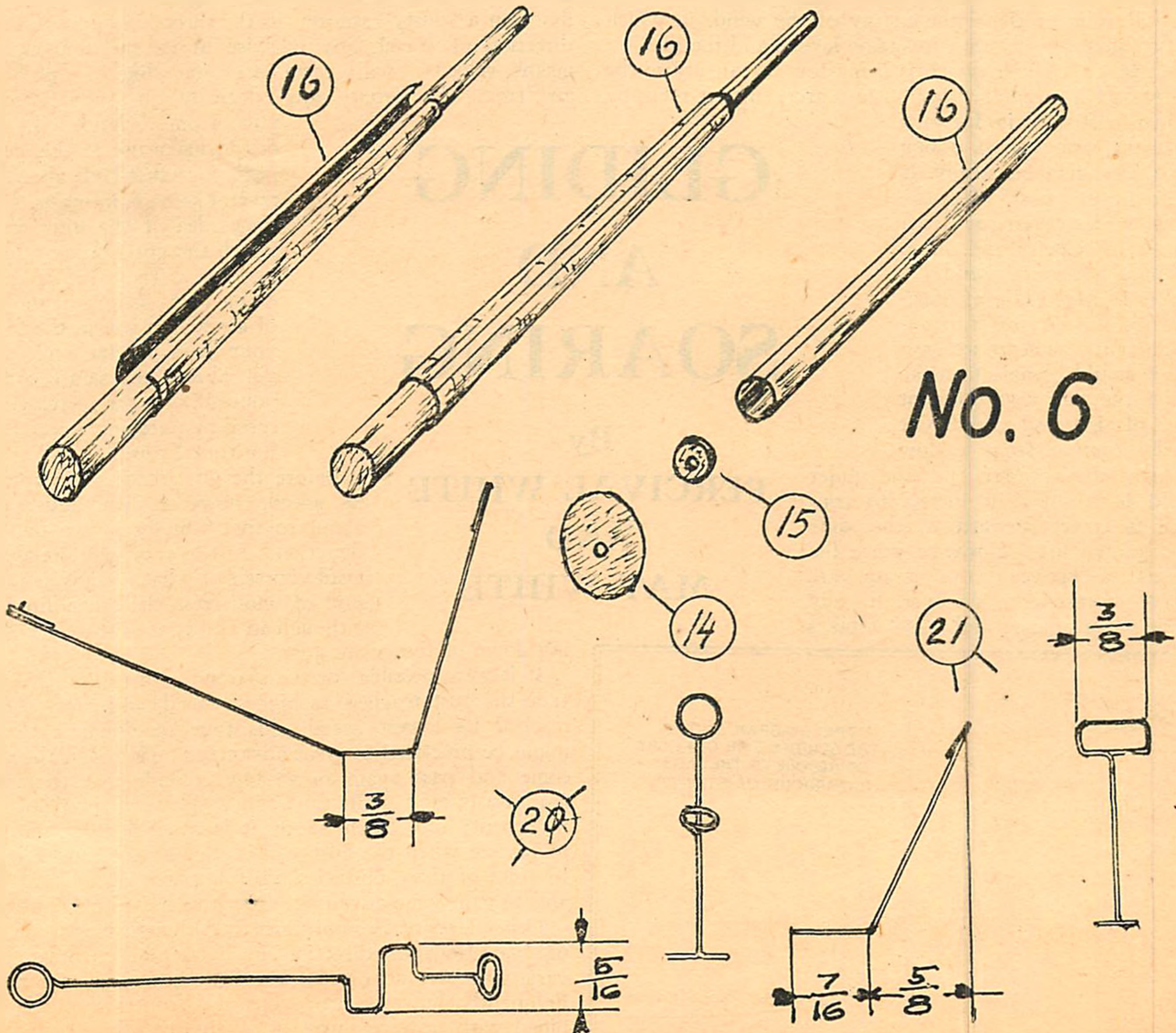



**W**HEN you have had considerable experience in static soaring, you are prepared to attempt some advanced and experimental maneuvers. Dynamic soaring is a science about which little is yet known, but which has possibilities of being developed so that the motorless plane will be as efficient as the soaring bird.

What is *Dynamic Soaring*? Dynamic soaring is done through gaining potential energy in the form of excess speed from variations in horizontal currents of air. (Static soaring, it will be remembered, depends on upward currents.)

Mr. William H. Bowlus defines the difference between static and dynamic soaring in this way: "Static sail flying is limited to the landscape, that is, dependent on it; whereas dynamic sail flying is based on the utilization of the inner energy of the wind, in which are turbulent air currents, inversion layers, and the like."

A kite, or a glider which is being towed, can utilize the energy of a horizontal wind; but a soarer, since it relies on its own inertia for its forward movement, cannot do so, as long as the wind remains steady. It has been found possible for the soarer to derive energy from changes in velocity and direction of a horizontal wind.

*How to Make Use of Variations in Velocity of Horizontal Currents.* Theoretically, a soarer should be able to make use of the fact that different strata of air travel at different speeds: coming from a slow stratum into a faster one, the glider would have sufficient inertia to continue to travel forward, at the same time gaining lift. However, since the boundaries between the strata are almost impossible to discover, by any means yet available, and since it takes



A German glider meet at Wasserkuppe

time to manoeuver, the glider, it has so far proved impractical to make use of the varying velocities of layers of air.

It is, however, possible to soar by means of the variations of velocity in any single stratum. When you are flying in a "gusty" stratum in the direction opposite to its direction of travel, any increase in its speed above the mean velocity will seem to you like a puff of air from the front; any decrease in speed like a puff from behind. In order to make use of this gustiness, you must glide ahead for several seconds in order to get some idea of the intervals at which the gusts occur. Then, as long as the wind is freshening (i. e., as long as the puff of air strikes you in the face), your own inertia will carry you ahead, and you can avail yourself of your increased air speed by pursuing a practically horizontal course.

Before the gust reaches the apex of its speed, however, you must turn about so that you fly in the opposite direction. In this way, you are able to avail yourself of what is equivalent to a puff of wind from the other direction, although in reality it is merely a slow-

ing down of the entire gust.

If it were possible for the soarer to turn instantly every time the gust reached its highest speed, and every time it reached its lowest speed, this type of dynamic soaring might be practiced to great advantage. However, the gusts come and pass again in so few seconds that the glider must waste most of its time and its forward speed in turning about; and, furthermore, it is impossible for the pilot to foresee when the gust will reach its maximum velocity. In spite of these obstacles, skilful soarer pilots have been able to gain some advantage from this means of flight.

*Other Uses of Frontal Gusts.* Although it is possible to use variations of direction in horizontal currents, these variations are, at present, of little practical importance. Frequently, however, variations of a frontal wind are combined with upward currents of air; and this combination may be very useful to the adept pilot. For instance, if you

# GLIDING AND SOARING

By  
**PERCIVAL WHITE  
AND  
MAT WHITE**

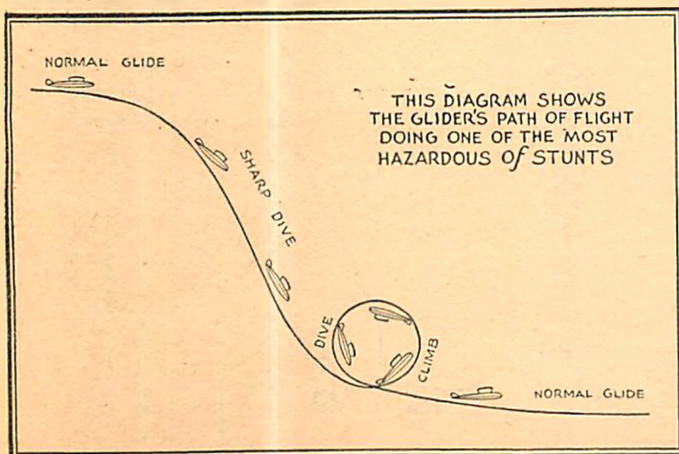



are flying in a horizontal current and in line with the direction of its movement, and if you then encounter an upward current which has no horizontal velocity, you can pull your stick back to get the full value of the rising air, while keeping flying speed because of your great momentum.

Although little progress has yet been made in dynamic soaring, every soarer pilot should learn as much as he can about it, in order to have a foundation for his own experiments.

*Maneuvers and Acrobatics.* While the acrobatics possible to the powered ship, due to its great speed, strong construction and controllability, are rarely practical for the glider pilot and usually impossible, there are certain maneuvers which the glider pilot often uses and which he may safely practice. They are not dangerous, as long as one performs them at a sufficient altitude to ensure recovery from them. A soarer, however, is very delicate, with little to spare in the way of a safety factor if put to undue strain and actually it will be the "stunt" flyer who attempts "stunts" in one.

## A MANUAL OF MOTORLESS FLIGHT

All acrobatics, of course, have an experimental value. They require a high degree of maneuverability on the part of the ship and a knowledge of the ship's reaction to them is important to the designer. It is possible that greater perfection of design will make the soarer pilot more efficient in the performance of stunts and may provide, in some degree, that agility which is necessary for successful dynamic soaring.

The type of maneuvering you can do in a glider is interesting and instructive and its practice will accustom you to recovering from all sorts of unusual positions, so that you will always be prepared for any emergency into which sudden wind changes might throw you.

*Intentional Stalls.* If you are a skilled pilot, at a good altitude, and in a ship of high performance, the practice of a few intentionally induced stalls is profitable and not dangerous. By practicing stalls, you will become accustomed to the feel of the controls when they have "gone out" (i. e., become useless through the loss of flying speed), and to the method of recovery.

The best way to stall the glider is to pull the stick back while you are in straight flight. The nose will rise for a moment, but eventually instead of climbing, the ship will "squash" downward through the air. The pilot's weight will tend to force the nose down again. In order to recover control, push the stick way forward; the resultant dive will allow the ship to regain flying speed. The illustration shows the movement of the glider during a stall.

*Sideslips.* A sideslip is the same thing which you were warned against in making turns, occasioned by insufficient rudder in proportion to the

amount of bank. As a means of losing altitude for a spot landing, however, it is very useful. In order to slip the glider, bank the ship, into the wind if possible. At the same time, apply opposite rudder. Before a sideslip, it is necessary to dive in order to gain speed; and the stick must be held forward during the slip,

Lindbergh in a  
Bowlus sail-  
plane

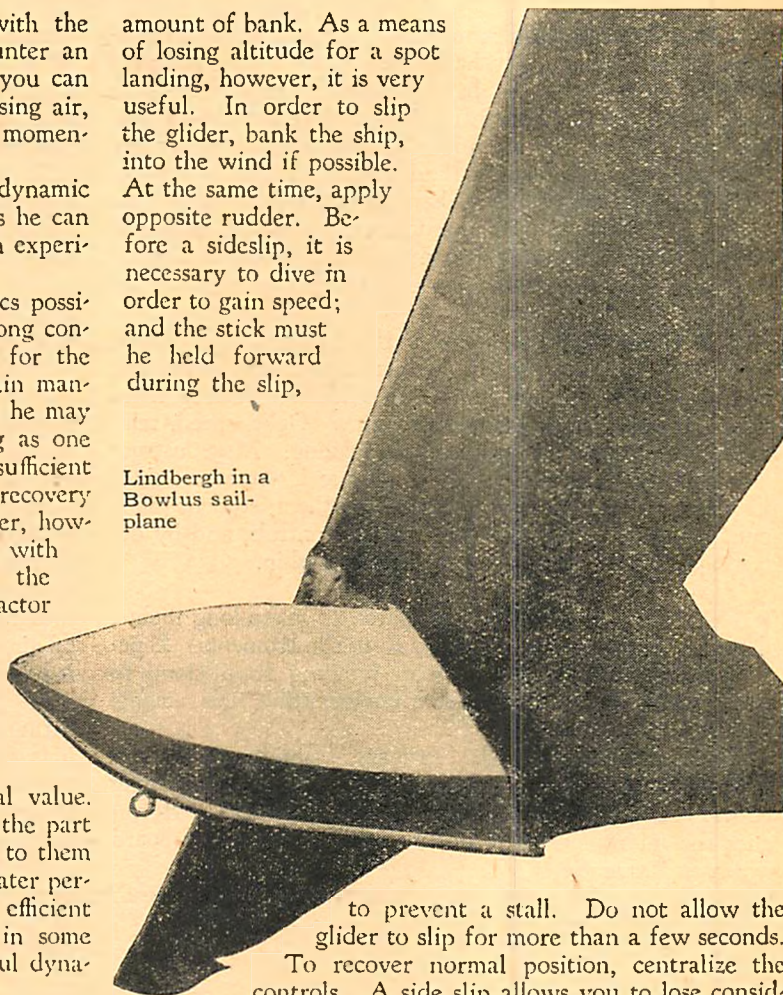

to prevent a stall. Do not allow the glider to slip for more than a few seconds. To recover normal position, centralize the controls. A side slip allows you to lose considerable altitude without traveling much distance over the ground.

*Spin-Loops.* Such maneuvers as these pass the border of plain flying and become stunts. In only a few cases are they attempted by the glider pilot. The spin may be the result of a prolonged stall or it may be caused more quickly by a skid. Successful loops have been executed in gliders, but they are extremely difficult since they require great speed, and an altitude of at least 3,000 feet; and there is little to be gained from them.

It is extremely unlikely that a glider will ever be banked steeply enough to necessitate the use of reverse control. If a bank approaching ninety degrees should ever be made, however, you should remember that the functions of the rudder and the elevators become reversed, in relation to the horizon.

*Conclusion.* Dynamic soaring is difficult. It presents an infinite field for experimentation and research. You should begin to experiment with it as soon as you are able, whenever you have the opportunity. Comparatively simple maneuvers such as those described may also be undertaken as soon as you are able to reach sufficient heights. Stunts or acrobatics, however, are best left to the man of great experience in the air.

### DURATION AND LONG DISTANCE FLIGHTS

The object of a duration flight is to remain as long as possible in the air, usually quite near the take off. The aim

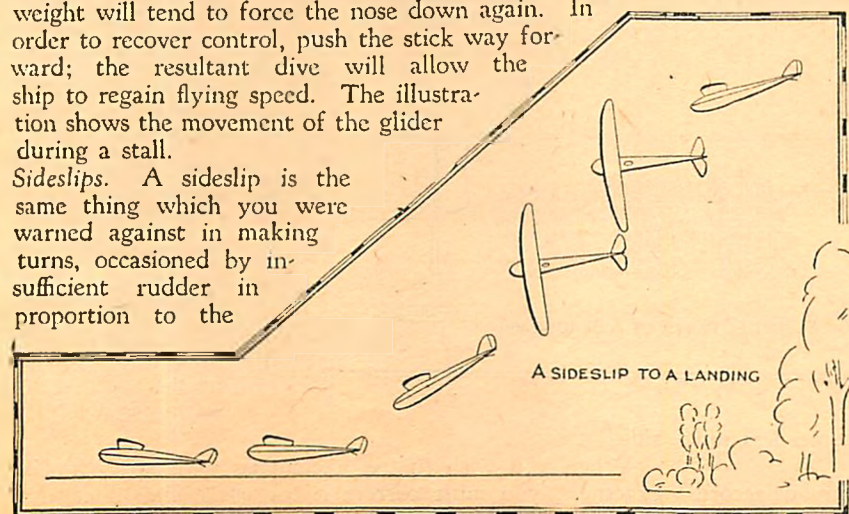

This is the tenth instalment of this absorbing series on Gliders and Gliding



of a long distance flight is to fly as great a distance as possible. Many long flights have been made within the past decade. Many of these have established new records in their fields. Most of them have contributed to the scientific knowledge of the air and all of them have materially increased the experience of the individual pilot.

Before you attempt to make a long distance flight, you should know how to read instruments; you should be familiar with the surrounding region; and you should be able to recognize the weather conditions suitable for such an attempt.

*The Value of Instruments to the Soarer Pilot.* There are a number of different aeronautical instruments, but many of them are not in use on gliders. Usually those which a glider needs are those to show height, speed, relation to the horizontal and compass reading. Most instructors think that beginners should not use instruments, since they are apt to grow too dependent on them; student pilots must learn to fly by the "feel" of the controls, and by detecting currents of air which strike the ship.

**E**XPERT pilots, who are prepared to make long flights, are, however, often obliged to use instruments. Especially in night flying or in jumping from cloud to cloud, when the horizon is often imperceptible, instruments are often indispensable.

*The Instrument Board.* Primary training gliders are seldom equipped with instruments. Secondary training gliders occasionally have them. On ships of high performance the instruments are fastened to an instrument board which is attached to the fuselage immediately in front of the pilot. The figures and letters on the instruments should be so large and clear that they may be read quickly by the pilot.

*Stability or Flight Instruments.*

The instruments used on soarers may be divided in two classes: stability or flight instruments, and instruments for navigation. The most widely used instruments of the former class are:

1. **Altimeter.** An altimeter is an instrument which shows at what altitude the ship is flying. It may be so set

as to register the height above sea level but usually is set to register zero at the valley level over which you are to fly, in contra-distinction to that of a motored plane which is set at the level of take off.

The indicator on the dial is commonly moved by an aneroid barometer. This barometer expands with increasing height as the air grows thinner, and contracts as the height becomes less and the air denser.

2. **Barograph.** The barograph gives a continuous record of the altitude registered by the altimeter, so that, at the

end of the flight, the pilot has a complete record of the heights which he has gained and lost. On test or prize flights this record will be sealed by the judges at the beginning and opened by them at the end of the flight. The illustration explains the way in which a barograph works.

3. **Bank Indicators.** There are several types of bank indicators. They do not show at what angle the ship is banked, but whether it is correctly banked, whether is skidding or slipping.

**O**NE form of this instrument consists of a small piece of glass tubing in a horizontal position, containing a bubble of air, or a tiny metal ball. As long as the ship is flying level or is banked properly for the speed and degree of its turn, the ball or bubble remains in the centre of the tube; but when slipping or skidding occurs, the ball or bubble rolls to one side.

Another indicator which gliders alone use is a small weather vane or wind sock attached to the fuselage right in front of the pilot (see illustration). This is really a yaw meter and registers one's deviation from a path directly into the wind as well as the presence of those side gusts of air, occasioned by skidding or slipping, which the pilot may not feel distinctly against his face.

4. **Air Speed Indicator.** No instrument for easily measuring ground speed has yet been invented; furthermore, it is air speed in which the glider pilot is particularly interested. An air speed indicator measures the pressure of the relative wind, and records this pressure on a dial graduated according to miles per hour. The pilot can tell from

this instrument how much kinetic energy in the form of excess speed he has stored up; i. e., how far the soarer is from the stalling point.

*Instruments for Navigational Purposes.* These instruments are important for long-distance flights.

The only navigational instrument ordinarily used in the glider is the compass. Although there is more than one type of compass, the usual magnetic or mariner's compass is the one best suited to the glider.

1. **Compass.** A magnetic compass consists of a freely

suspended magnet, usually mounted on a card, which points toward the magnetic north. A magnetic compass is made temporarily ineffective by a bank of about twenty degrees. Therefore, before reading the compass, the pilot should maintain straight flight after a turn, until the needle ceases to swing from side to

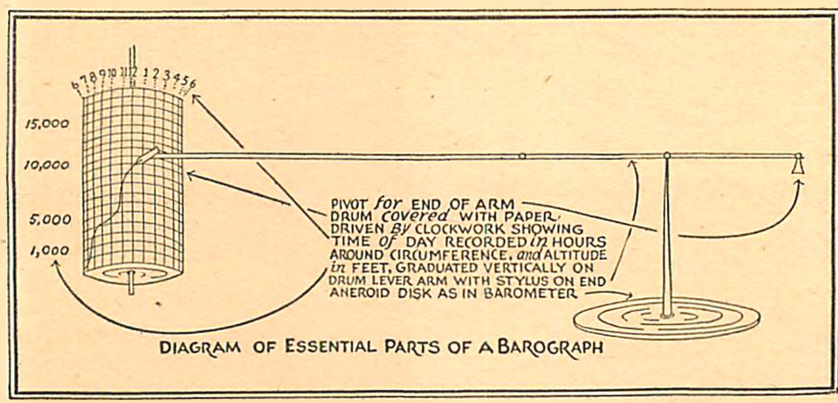
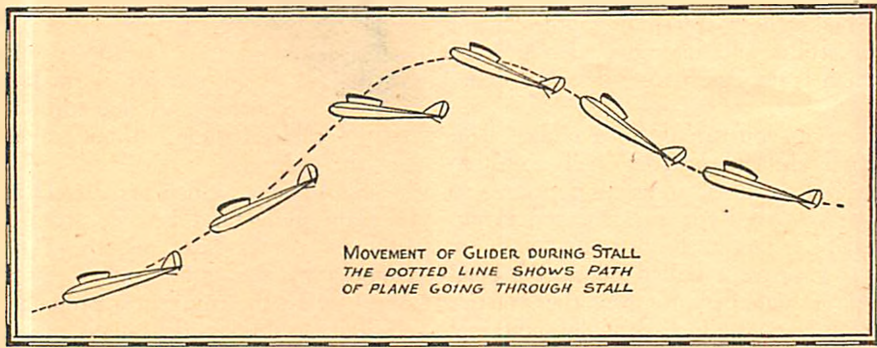

side. When you wish to use a compass with any degree of exactness, you must correct it for variation. This variation is due to a difference  
(Continued on page 41.)





Is Young America interested in making things with its hands? Some indication of the answer may be found in above picture, which shows the association of American news boys presenting a miniature Napoleonic coach to President Hoover, in a ceremony at the White House during the boys' recent convention there.

Hundreds of these boys are not only contributing to their own support by selling papers, but also find time to work on coach models in their leisure hours, in the hope of earning university scholarships or other substantial awards offered by the Fisher Body Craftsman's Guild.

More than 125,000 boys of high school age are now at work on these coaches.

## The American Sky Cadets

**J**OSEPH SHEEHAN, JR., twelve years old, who "sat on a soap box and two cushions" and flew a Byrd biplane over Garden City, Long Island, for half-an-hour in January last, was guest of honor at a reception given in the Boys' Shop at Stern Brothers, New York, recently. American Sky Cadets exhibited their model planes at the reception.

It was hard to make a "fuss" over Joseph because he didn't think he had done anything worth "fussing" about, even though he is just about the youngest aviator on record to have accomplished a solo flight.

Joseph is willing to talk about airplanes, but he hasn't much to say about himself. You have to ask his father, Joseph Sheehan, Sr., who is cashier of a bank in Suffern, New York, to find out how this bright looking boy, now in the sixth grade in the Suffern public school, first became interested in aviation.

Joseph started to "make things go" way back in his nursery. At six he wanted to be a truck driver. And because he was lucky enough to live on a farm with plenty of tractors, rollers and mowing machines, he had a chance to see machinery in motion when he was still a boy.

When Joseph was eight years old he gave his family a shock and a surprise. One morning, when his

mother was looking out of the window of her home she saw the car of one of the workmen on the farm back into the road, reverse and start to move forward. There didn't seem to be anyone driving it, until she discovered the top of young Joseph's head, just above the steering wheel. Before she could rush downstairs, he had driven the automobile half way down the road!

"Joseph couldn't get a license because he was only half as old as the law requires," said his father, "but he just kept on driving these past four years, and now he does it better than I can."

Soon Joseph learned to drive tractors and steam rollers, and at last, one day last summer, he visited Kakiat Field near his home, looked over the planes, talked to some of the instructors, and determined to become an aviator!

It was Okey Bevins an instructor from Hasbrouck Heights, N. J., who really taught him how to handle the controls. And on January 18th, after flying to Roose-

velt field with Bevins and his father, Joseph took a Byrd biplane in the air alone for half an hour, and brought it down for a perfect landing. When he climbed out of the plane he didn't even guess that he was news!

Stern Brothers, the big department store on 42nd Street, thinking that a lot of boys interested in avia-

### Why Capt. Hawks Flies

*"If any of the cross-country speed records which I have made offer incentive to others to excel, I shall always feel my efforts have not been in vain, but will bring real results. There is no object in flying from city to city for the mere purpose of establishing a record unless the fact that it can be done is recognized as an advancement to aviation.*

*A record of itself is worthless unless it can be pointed out as a definite marker to which all other commercial aviation enterprises can aim at as a goal for logical daily operation."*

(See page 27)



tion would like to meet young Sheehan, invited him to their Boys' Shop for a reception on the Saturday following his solo flight.

Captain Loftus-Price arranged for the American Sky Cadets to exhibit some of their best models at Stern's on the same occasion, and there was great interest in their fine reproduction of famous planes.

The model makers who exhibited were: Joe Battaglia with a Vought "Corsair" Navy Scaplane, Boeing "P-L" Sports plane, the Battaglia Fighter (original design), Travelaire "Mystery S" low-wing monoplane, Boeing "P-12" Sports, and model of the "Spirit of St. Louis;" Jesse Davidson with the Keystone-Leoning Amphibian, a tapered-wing Waco racer; Morris Silberberg with the DH. sports plane; Joe Friedland with an Aeronca sports plane; Joe Rothstein with a Ford-Stout tri-motor monoplane; and Melvin Wofsy with his Westland "Wizard," a R.A.F. single-seater fighter.

Another feature of the afternoon was an exhibit of more than a hundred pictures from "The World in the Air," the new book published by Putnam's, which tells the whole thrilling story of aviation from the first balloon flights to the air conquest of the Atlantic Ocean.

The American Sky Cadets later gave a demonstration of actual model making at the work bench at Stern's, during another reception at which "Casey" Jones, Lieut. Harry Connors, Capt. Errol Boyd, Capt. Loftus-Price and other noted airmen were guest speakers.

**BAMBERGER AERO CLUB**

**T**HE Bamberger Aero Club organized last year has been growing steadily until it now numbers more than 600 members.

As this club is a striking example of success in the formation and running of a model airplane club an outline of its work might be of interest to other clubs and perhaps help some which have not proved as successful as the originators wished.

For any club, whether of boys or of adults, to succeed it must hold the interest of its members. This means that the officers of the club must be continually on the lookout for new ideas and each member should have an incentive to keep him on his toes. Whether the club is a group of six boys meeting in the woodshed or a group of six hundred boys meeting in a large store it depends entirely on the officers of the club whether it will be a success or not.

Aviators and local business men are only too ready to help if you can prove you are in earnest in your interest in aviation and are not only looking for fun.

There are eight stages through which the member works. In the Bamberger Aero Club, these are graded according to models constructed, proficiency time for each model,



Joseph Sheehan, Jr.

The grades are as follows:

| Model                 | Rank                      | Proficiency Time | Honor Certificate Time |
|-----------------------|---------------------------|------------------|------------------------|
| R. O. G. ....         | Student Flyer.....        | 15 sec.          | 45 sec.                |
| Senior R. O. G.....   | Unlicensed Pilot.....     | 25 sec.          | 75 sec.                |
| Tractor .....         | Private Pilot.....        | 60 sec.          | 180 sec.               |
| Commercial .....      | Limited Commercial.....   | 15 sec.          | 45 sec.                |
| Outdoor Fusilage..... | Transport "A".....        | 20 sec.          | 60 sec.                |
| Twin Pusher .....     | Transport "B".....        | 60 sec.          | 180 sec.               |
| Scale Model.....      | Transport "C".....        |                  |                        |
| Racing Pilot .....    | Win place in contest..... |                  |                        |

The club members are at present experimenting on Autogyros and outstanding work has already been done in this line by Philip Zecchitilla, John Cadley and Herman Becker. The next model will be a dirigible.

From time to time outstanding figures in aviation address the boys at their meetings. Among those who have already done so are Capt. Frank Hawkes, the late Frank Goldsborough, Robert Buck, of Elizabeth, Count von Luckner, R. Branberry and Mr. Graham Curry. The last named also exhibited his model of a Lockheed Sirius which required 100 hours to build and is perfect to 1/20th of an inch.

Other prominent aviators are to speak in the near future and the members can look forward to an interesting and profitable session.

The new club room is double the size of the old one and fitted up with work benches for the use of the members. Aviation pictures adorn the walls while tables hold interesting exhibits. The club is-

sues a weekly bulletin to its members advising them of meetings, promotions and coming events. Three contests were held last year with further contests scheduled for 1931. Representatives of the club will be sent this year to make a strong bid for the first prize at the Detroit Contest.

Among the members figure such champions in the model airplane world as Alexander Dallas, Thomas Boland, Welcome Bender, Jr., Henry C. Runkel, Theodore Bellack, Alan Urdang and Nick Tremarco.

The officers of the club are: (Continued on page 37)

**America's Youngest Pilot,  
Joseph Sheehan, Jr.,  
Holds Court After  
His Great Feat**



# How To Build

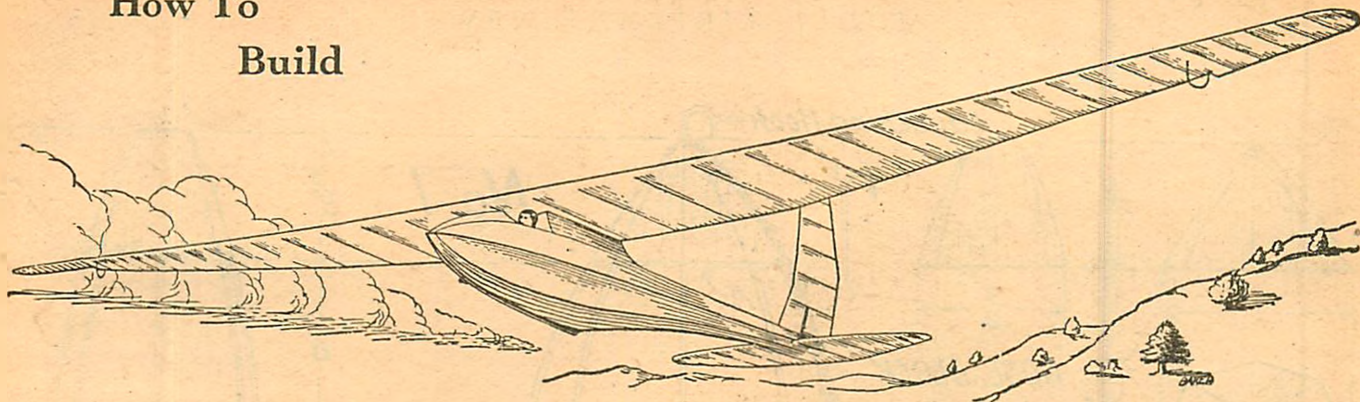

## The BOWLUS SAILPLANE

by  
Jesse Davidson

**T**HE famous Bowlus sailplane, which was designed and built by W. Hawley Bowlus of San Diego, California, (designer also of the well-known "Spirit of St. Louis") can be classed as one of the world's most successful sailplanes.

Two important records have been established in Bowlus craft: one being the American duration record made by Mr. Bowlus, himself, of 9 hours, 5 minutes and 32-2/5 seconds, and the world's record formerly held by Lieut. Dinort of Germany, which was surpassed by Jack Barstow, who remained in the air for 15 hours, 12 minutes—27 minutes longer than the previous record.

The scale drawing plans given here are exactly reproduced from the manufacturers' plans of the glider. A model made by the author was launched from all sorts of localities and found to inherit the same excellent gliding and soaring qualities of the big ship.

It is well to point out at this time that the success of this model will be due to its strength, rigidness and lightness.

### FUSELAGE

The fuselage requires care and patience in its construction. The bulkheads A to H are cut from 1/32" thick balsa wood. Cut out small notches to accommodate bamboo stringers, which are the longerons for the fuselage. Ambroid cement is used for gluing. After completing the fuselage, make the wing mount, as shown in drawing, from the piece of balsa, 1/2" x 3/4" x 2 1/2", and the nose piece from balsa 1 1/2" square.

The nose piece is glued and held firmly to bulkhead. Then the tail skid is affixed and glued as shown in plane. The nose hook is made of a heavy piece of wire No. 9 and glued in position.

### TAIL SURFACES

The tail surfaces of the Bowlus sailplane are so distinctive that there is no difficulty in distinguishing them



~ METHOD OF LAUNCHING ~

from any other type of sailplane. These surfaces are made of bamboo and balsa. For the spar in the rudder, use one strip of 1/32" bamboo. Balsa 1/32" thick is used for the ribs. These are streamlined, as illustrated in drawing. Bamboo spliced to 1/32" is used to outline both rudder and elevator. The elevator ribs are also made of balsa 1/32" thick. Now lay these aside.

### WINGS

The long, narrow wings of a sailplane give it exceptional stability. The ribs of the wings are different sizes and are cut from 1/32" balsa. A slot is cut out in each rib to fit the leading edge spar of 1/16" x 3/8" hard balsa. The center spar is made of 1/32" sq. bamboo and is glued into notches below each rib.

Be sure that the ribs are in perfect alignment. After cementing ribs in position, use 1/32" split bamboo for the trailing edge and for rounding out the wing tips. A right and a left wing are needed and make sure that both are of the same weight.

Next fit in the 1/8" dia. dowels and 1/8" dia. aluminum tubing for attaching and detaching purposes. Note that these are set opposite each other (see drawing). Sand down the dowels slightly to fit the aluminum tubing.

### CENTER SECTION

This is where the right and left wings are to be attached. The leading edge, center spar, and trailing edge are of the same material as used in the wings. Now fix in the dowels and tubes and set aside to dry.

### COVERING

The wings, body, tail and center sections are covered with fine Japanese Hakone tissue. First cover up the fuselage. It is advisable to cut up your paper in strips to avoid wrinkling. Ba-

(Continued on page 38)



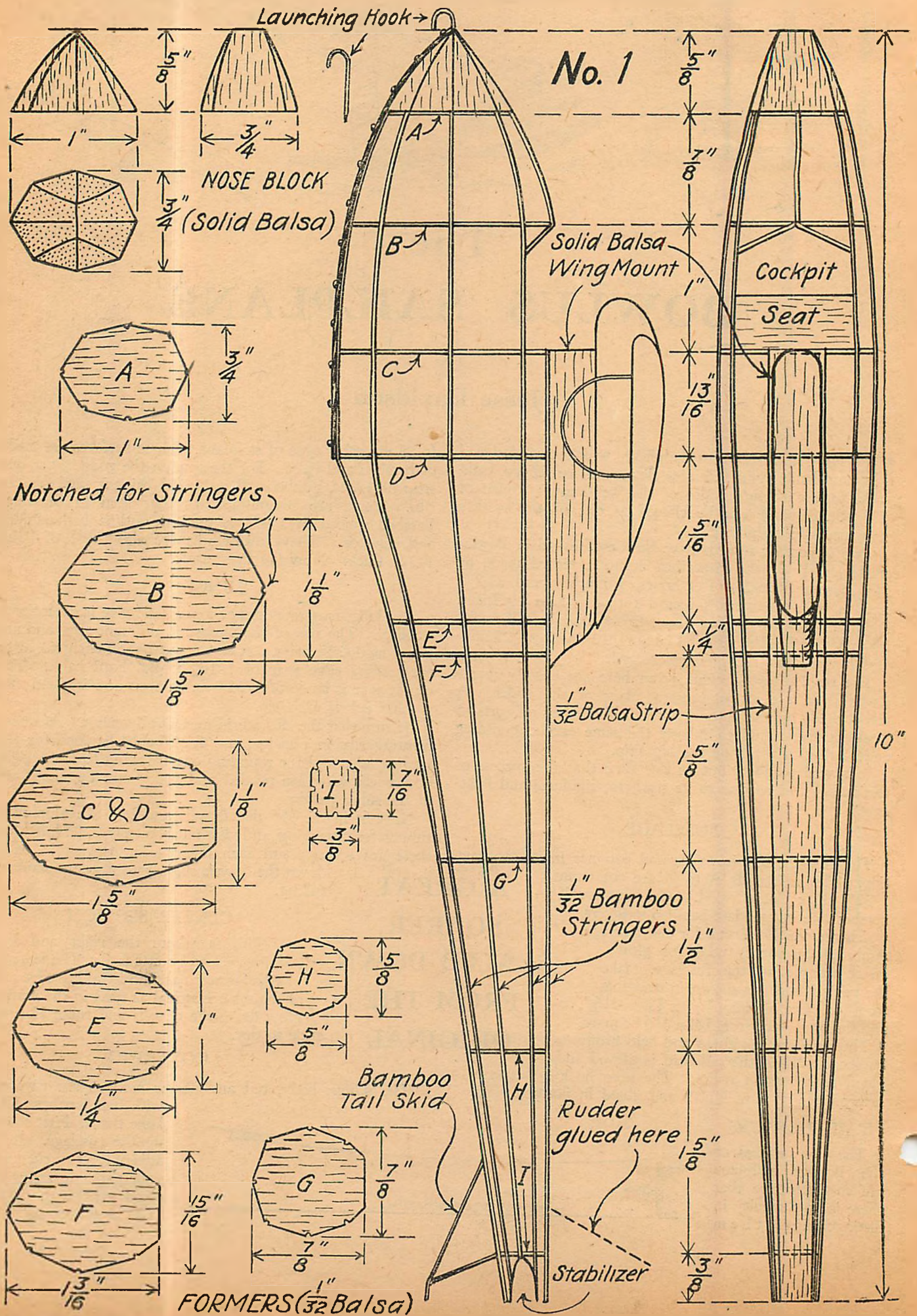



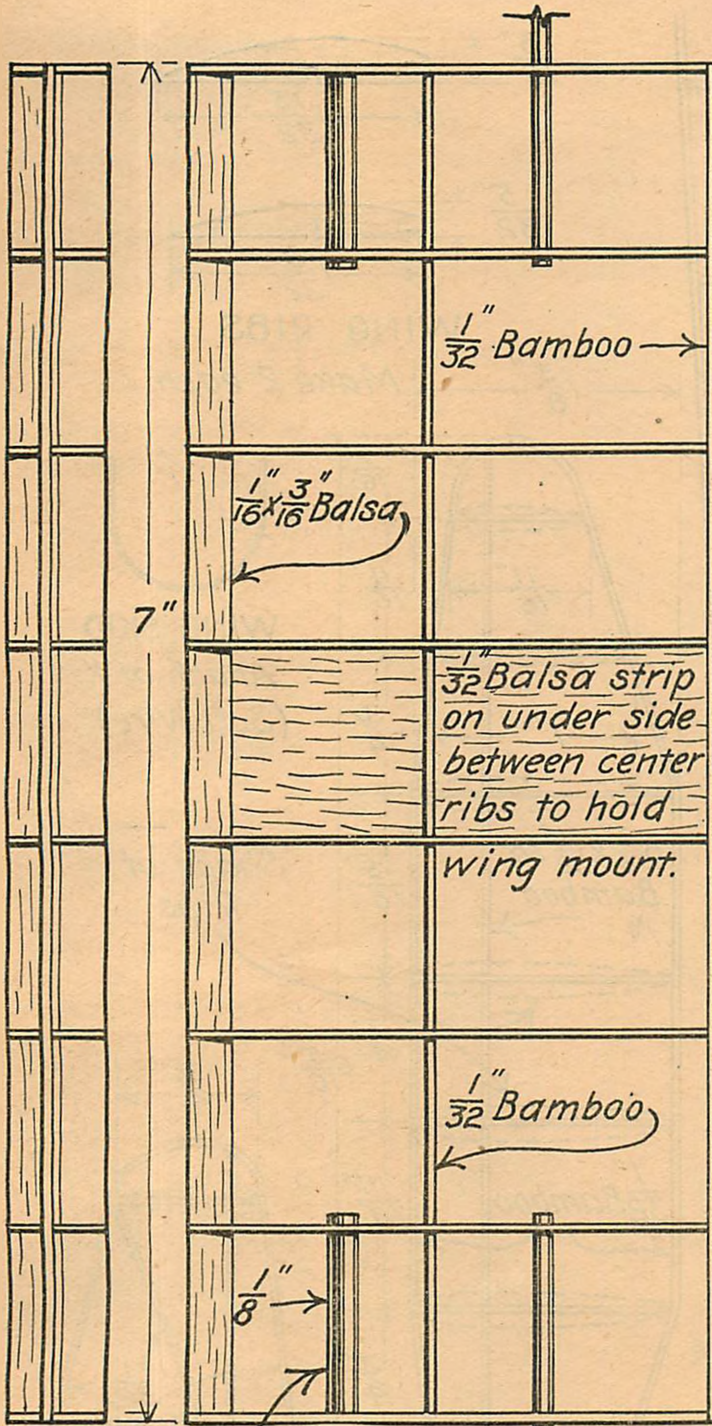

Aluminum Tube  
 CENTER SECTION  
 No. 2  
 Dowel sanded to fit tube

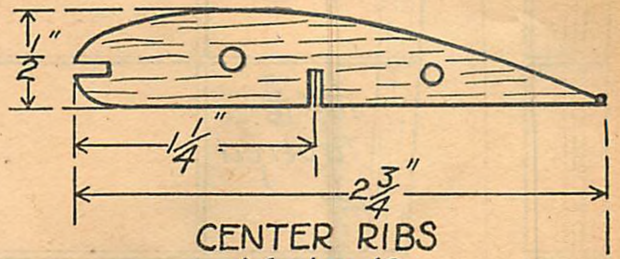
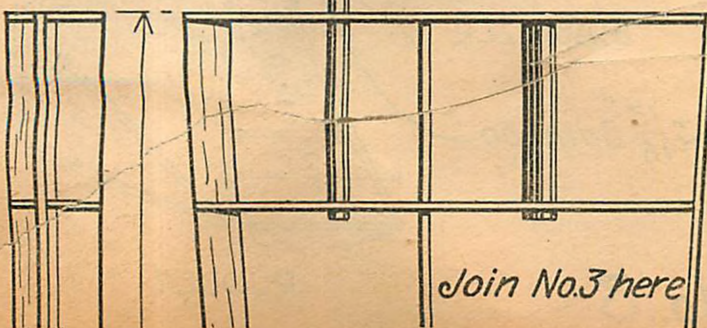

CENTER RIBS  
 Make 10 of 1/32 Balsa

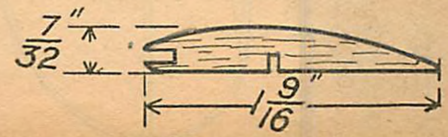
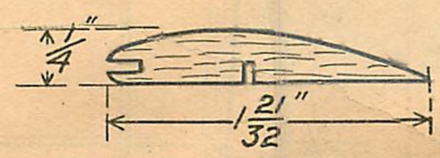
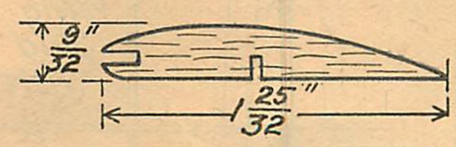
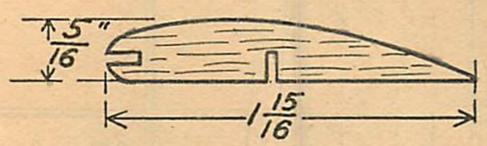
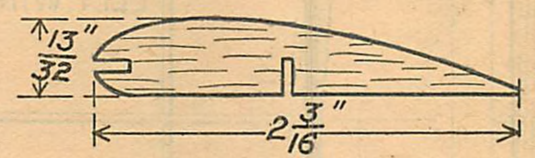
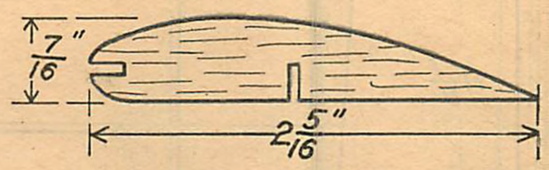
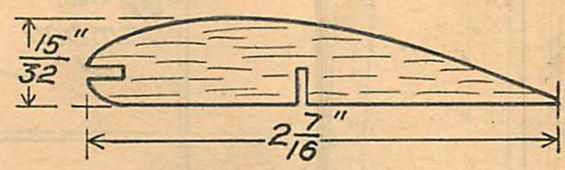
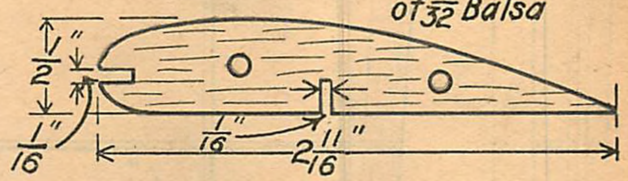



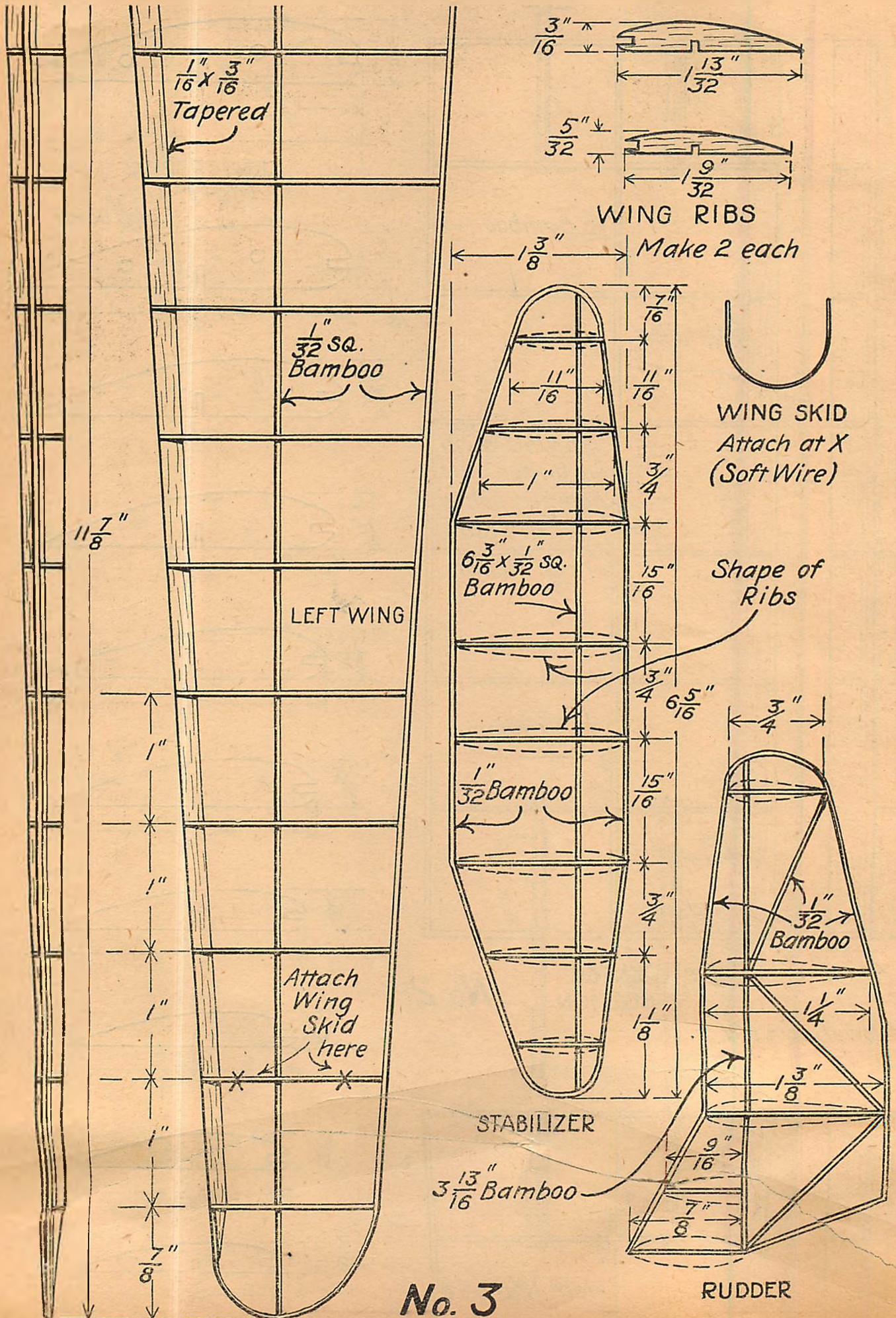

No. 3



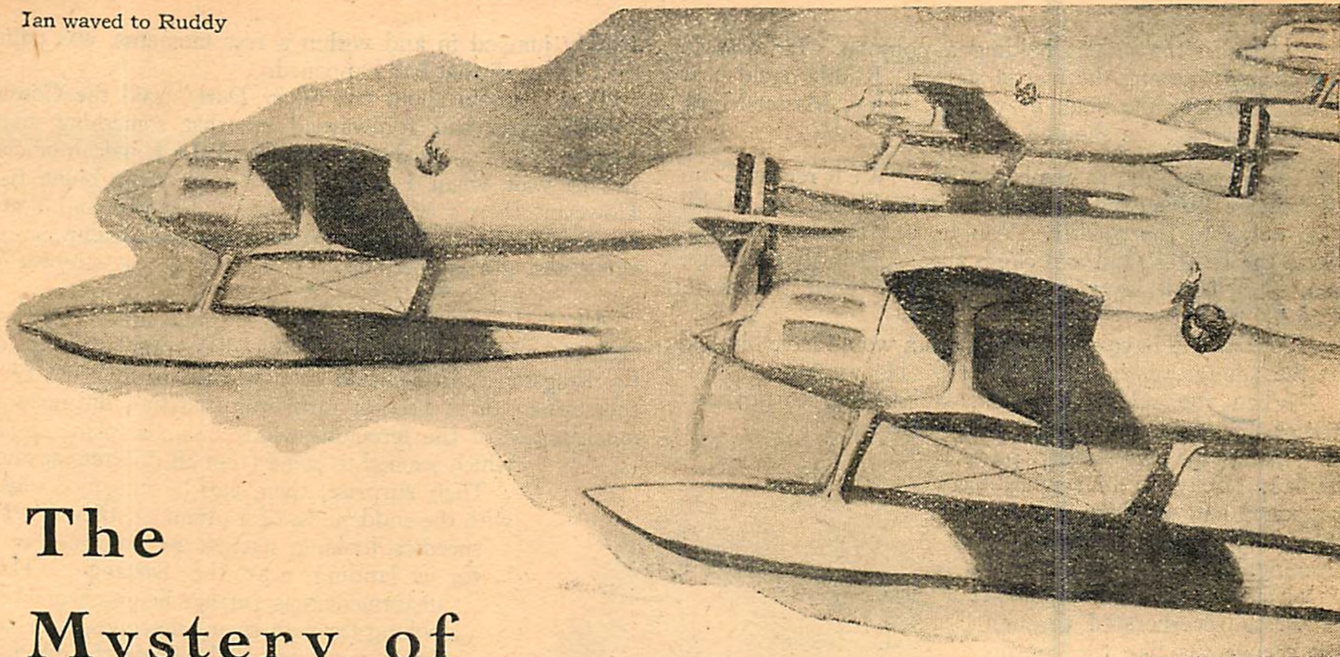

## The Mystery of

# THE SILVER DART

By RAY GREENA

**L**IEUT. IAN POTTER, nineteen, and an outstanding flyer in the U. S. Army Air Corps, accidentally intercepts a wireless message in code virtually out of the air, while he is a guest at the home of Commander Stevens. He believes it concerns the Silver Dart, a new mystery fighting plane secretly developed by the government, which has recently been stolen. Its loss has startled the inner circle of official Washington, though it gives no indication to the outer world of the outrage, and it was only through a chance bit of gossip that Ian had heard of it.

He is advised by his friend, Captain Yubanks, to consult Rear-Admiral Beecham of the Secret Service about the message. There it is decoded in part. It is about the Silver Dart. The Admiral concocts a scheme whereby Ian is ostensibly to be discharged from the Air Service in disgrace, but is really left free to undertake a private flight to the West Indies, which place was mentioned in the message. Once there he is to try to solve the mystery. Ian takes off for the tropics with his friend, Ruddy Arnold, in a borrowed Fokker.

Meantime, a secret wireless receiving set is unearthed by the Secret Service in the home of Commander Stevens, and he is sent away on a special mission so that they can work freely on the mystery. They order three of the Navy's fastest cruisers and aircraft carrier, Saratoga, to Jamaica, and the Commander at the Naval Base there is notified to meet the Fokker coming down. He flies out to sea in a plane and meets it, giving Ian two revolvers, ammunition and bombs, and they proceed to Jamaica.

There Ian and Ruddy fly over Kingston, and then suddenly dive into Hunts Bay—their goal—as if in a spin. The inhabitants think it is the end of the two men. However, they were merely putting everyone off the scent. They fly on and locate the submarine mentioned in the wireless message. After a

terrific struggle through the mangrove swamp, they go aboard the submarine and capture the man on watch. However they are taken aback when they find the Silver Dart on the deck of the submarine but apparently immovable.

**I**AN was stunned for a moment. The guard must have sensed the situation, for he was grinning—no, leering, would be a better word—at them. Slyly he looked at Ian saying:

"Me go, me tell!" Ian calmly walked back to the conning tower, picked up the cutlass and dug the point into the small of the man's back.

"You don't go and you're going to tell. Get me? If you don't, out comes an inch of flesh. And that'll happen until you do tell. Now out with it!" He put action into his words by digging harder with the cutlass. The man winced.

Two or three more digs, and he spoke, explaining in halting fashion how the small brass wheels in the conning tower controlled the flow of water into the trough, allowing sufficient flow to float the plane with full load, and at the same time, lowering the stern plates to allow the plane to take off direct from the trough.

Ian and Ruddy, needless to say, were astounded! Here was a foreign government experimenting with a new type of submarine seaplane carrier of which nothing, so far as they knew, had even been dreamed about in America! Gosh, what a story to tell Admiral Beecham!

However, this wasn't the time to speculate. Without further ado, Ruddy shouted to Ian to climb into the plane, while he dashed into the conning tower and turned the brass wheel. Immediately the stern plates slowly began to drop and as they did so, the sea water began to fill the trough. Soon the Silver Dart was afloat.

Ruddy came back and stood

ALL'S WELL THAT  
ENDS—AS WELL  
AS THIS



knee-deep in the water, holding a pontoon. Ian was in the cockpit working the inertia starter. Ruddy could hear the whirrrrr of the small fly-wheel. "Hey, Master-Mind, how about me?" he shouted.

**I**AN signalled him to climb aboard. "We'll repeat Commander Strangway's mid-ocean trick," said Ian. "I'll taxi down to the Fokker. You lie out on the wing-tip. Grab the Fokker's tail and climb aboard, then fly to Kingston. I'll beetle over to the *Saratoga* with this bird. Got it?"

If looks could have said anything, Ian would have blushed at the admiration in Ruddy's eyes. He went on.

"When you get to Kingston, say nothing to anybody except the American Consul. He's sure to be among the welcoming party. Explain briefly to him what has happened and tell him that I'll be along later in a Douglas or a Loening."

Ian started the engine, the noise of which reverberated through the mangroves like the continuous peal of thunder. Without even waiting for it to warm up, he gave her the gun and the *Silver Dart* soon was splashing out of the mangrove "hangar" and towards the Fokker. Twice Ian missed the tail and had to circle back, before Ruddy at last caught hold. Then, with a wave of the hand, Ian pointed the *Silver Dart* out to sea and with a roar like a sixteen-inch cannon, and throwing up the spray, the trim little seaplane was off and soon out of sight.

Ruddy, meanwhile, had climbed down on to the pontoon and released the Fokker, allowing the tide to carry the plane out and away from the mangroves. Soon he had started the engine and had taken off for Kingston. The Fokker rose from the water without any trouble at all, owing to the fuel being nearly used up and, of course, less weight than when the flight down was started.

He landed opposite the Municipal Pier and taxied in. There was the usual cheering, hand-clapping and shouting, and all steamers in the harbor were blowing their sirens incessantly. However, most of the earlier crowd, disheartened by what they thought to be a tragic end to the flight, had left.

All the officials had returned to their residences and only a few of their representatives were on hand. A boat was sent out to tow the Fokker, and those ashore were bewildered when only one man stepped from the plane.

"Where's the American Consul?" asked Ruddy. "I want him—quick."

He was told that the Consul had returned to the Consulate, but that there was a car waiting to take him there.

Ruddy jumped in and within a few moments, was telling the Consul all that had happened.

"Yes, I know about the *Silver Dart*," said the Consul. "Washington had forewarned me that something might happen. It was for that reason I told the Jamaican officials not to wait when I saw you go down over *Hunt Bay*. However, there's a banquet arranged for you and Potter this evening at the Officer's Mess at Up Park Camp, so run along and get washed up. You need a rest, anyway."

\* \* \* \* \*

All look-out men on the *Saratoga* and the three cruisers, which were in their "parallelogram" position off the Kingston coastline, had been warned to look out for a submarine. So it was not surprising that they did not take much notice of the ferocious whine of an airplane engine which seemed to come from all quarters at once.

Their surprise, then, can be imagined when, with the suddenness of a plummet, they saw the speediest-looking, nattiest seaplane diving in for a landing near the *Saratoga*. Their amazement was further heightened when, looking through their telescopes, they saw that a man was tied astride the fuselage behind the pilot.

Fortunately, there was only a gentle swell running, so that Ian did not have much difficulty alighting. It was no sinecure, though, with the weight of the guard keeping the seaplane tail-heavy.

He taxied in under one of the *Saratoga's* booms, where eager hands helped him to moor the plane. Soon he and the guard—who, incidentally, had fainted and still was "out" when put aboard the *Saratoga*—were hoisted up.

Ian was taken immediately to the captain's cabin, where clearly, though concisely, he related all that

had happened.

"Well done, my boy," said the captain. "As pretty a piece of work as ever Washington has pulled off. Now, how about this submarine?" he added.

"Didn't stop to pick up any details, sir," answered Ian. "Don't even know to what government she belongs. I do know, though, that she's a beauty, and I'd love to know how they berth the planes aboard. I happened to notice while flying the *Silver Dart* here, that they have altered her somewhat.

"The wings have been cut at the center-section and made to fold back. So I presume that they must have some sort of a hatchway with an hydraulic platform which lifts or lowers the plane into the submarine. Then the hatchway is closed and made watertight for submerging. That's pure conjecture, sir."

The captain nodded. "Seems pretty reasonable guessing, though," he commented. "Well," he went on, "I suppose you're pretty tired and dirty. Let's see if we can find you some clothing and a bath. While you're changing, I'll give orders for a Loening to be made ready to take you in to Kingston."

Ian thanked him and soon (Continued on page 43)

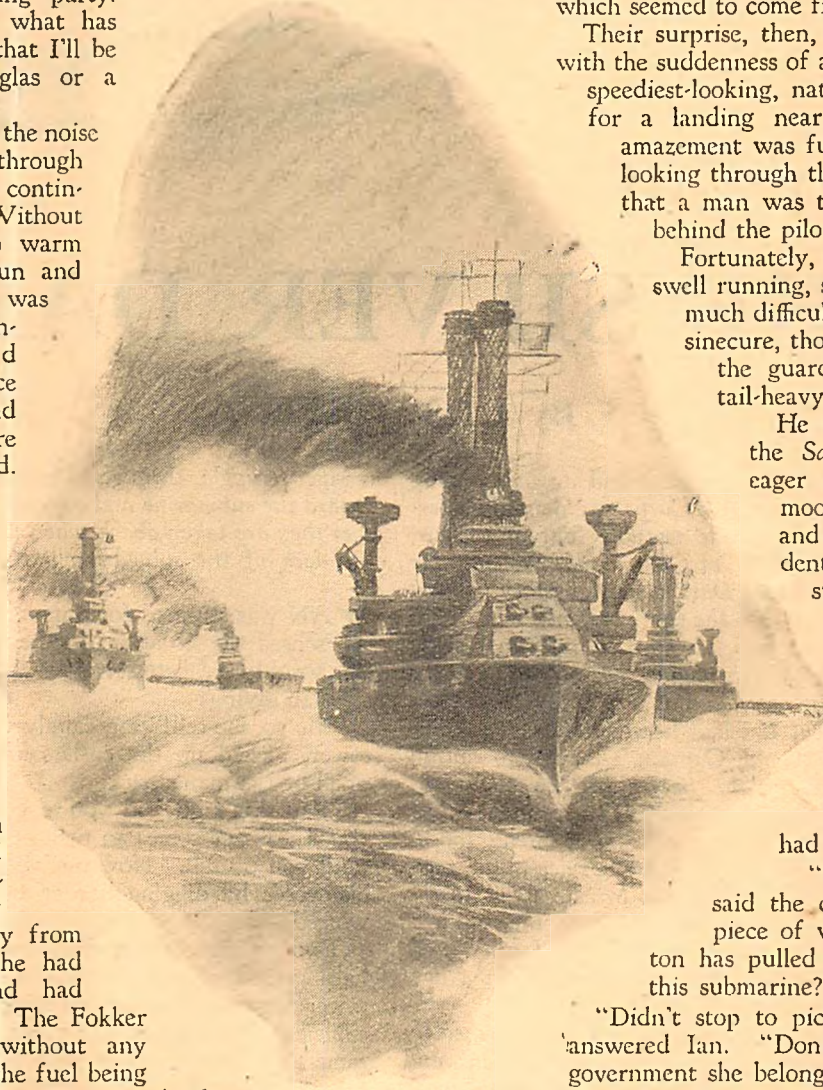

They plowed their way through



# The Story of America's Human Bullet

**T**HIS is a story not frequently told about Frank Monroe Hawks, but it is significant to any narrative about the man and his accomplishments:

Back in 1926, months before Lindbergh, Chamberlin and Byrd lined their planes up at the transatlantic air derby barrier at historic Roosevelt Field, Hawks had a notion himself to fly over the Atlantic to Paris.

At the time Hawks was a joint operator of an airport at Houston, but "pickings" were poor, and Hawks was comparatively unknown. But he had met James Rockwell, Jr., financier.

Hawks told Rockwell his idea. He wanted a tri-motored plane, a couple of ham sandwiches, and a map showing the route to Le Bourget, Paris.

"I can make it," he said, "and I'd like to land during the Legion convention. Who would be willing to back me?"

Knowing his man, Rockwell believed he could do it. He told Hawks to see Will Hogg, real estate operator; Jesse Jones, publicist and capitalist, and Will Carter, real estate operator and banker. Hawks saw Jones, and explained his plans. The decision, while not definite was encouraging, and Hawks came away grinning and

was following up his other leads when Lindbergh on an overnight's notice roared down the runway at Roosevelt Field and less than 35 hours later landed in Paris.

Hawks was unperturbed, and began developing another idea—speed. He had thought of the transatlantic flight as a grand adventure only for the first one to make it, and when Lindbergh succeeded Hawks took to fast airplanes and unprecedented cross-country travel. But more anon.

At 8 a.m., on Sunday, March 28, 1897, in Marshalltown, Iowa, Frank Monroe Hawks first saw the light of day—and that at a time when the claim of the Wright brothers that men might eventually fly like birds was but a nebulous theory. Aviation and Hawks, however, developed mutually, in a way of speaking. Came the famous flight at Kitty Hawk and all the grand subsequent developments. Meantime, Frank Hawks grew—through the

## A Free "Flip" Started Capt. Frank Hawks on His Amazing Career

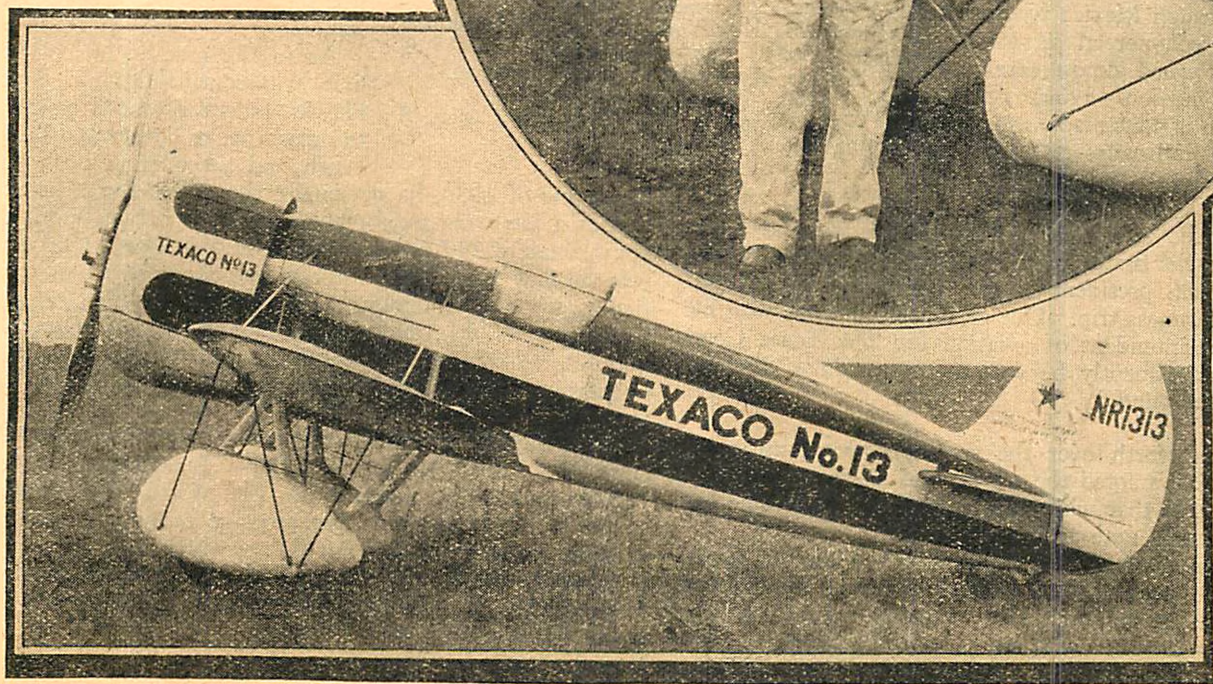



grade schools in Marshalltown and Minneapolis—through a little career as a character player with a Minneapolis stock company—through high school at Long Beach, California.

At Long Beach something significant happened. A barnstorming aviator named Christopherson was hopping passengers over Long Beach. Twenty-five dollars a hop. It might well have been a million so far as young Hawks was concerned, since he felt a million was as reachable as twenty-five. Even at that time Hawks was developing the imagination that years later envisioned some of the most sensational flights of his time.

Posing as a reporter for a local paper, Hawks approached Christopherson offering free publicity in "his newspaper" in return for a free ride. The bargain was sealed, and Hawks obtained his first hop. The seed was planted. Hawks wanted to learn to fly. He confessed his lie to Christopherson, and after being forgiven, became the ground crew for the ship.

After that Hawks entered the University of California, but in his sophomore year of an arts course at the school, the United States entered the World War. What came next is rather obvious: Hawks appeared on the records of Love Field in Dallas as a student of aerial science. He was commissioned within a few months and subsequently became an instructor—at the expense of being sent "across" for combat duty. It was hard to swallow then, but it was a compliment to ability.

Out of the army with the rank of captain, Hawks barnstormed over the country, took a fling at the air mail game, and finally purchased a plane and set off adventuring through Mexico where he set up a commercial service. Here he performed almost every conceivable mission—flying oil payrolls when bandits made it too hot for the railroads—stunting with air circuses—and carrying passengers.

This nomadic adventuring through Mexico and again back through the States went on until 1927, when Hawks took Burt Hull, president of the Texas Pipe Line Company, on a business trip. Out of this job Hawks won his berth as superintendent of aviation for The Texas Company, and subsequently he rode to fame, almost literally "sitting on the wind."

**B**ACK and forth over the transcontinental air trails Hawks has piloted the fastest and slowest aircraft of his time, so that while still in his early thirties he has won international note as an aviator.

Two fast monoplanes, one high wing and another squat, and a glider were the aerial perches on which Hawks first won national recognition. Fast airplanes, he said, propagated the primary value of aviation—speed; gliders and gliding, he explained, contained all the fundamentals of flights and accordingly provided a perfect medium for stimulating

interest in flying as a profession or as a sport.

In the spectacular era of aviation following the Lindbergh flight to Paris when the oceans and the transcontinental trails were attracting adventurous airmen, Hawks and Oscar Grubb, a mechanic, of Los Angeles, roared non-stop in the Lockheed "Texaco 5" from Los Angeles to New York in 18 hours, 21 minutes, 59 seconds. This trip, made in February of 1929, was the fastest cross-country flight on record, and although the time was subsequently beaten, it established Hawks among the great flyers of the country.

## FLIGHT RECORDS

Established by

### CAPTAIN FRANK M. HAWKS

Non-stop New York to Los Angeles, 2,500 miles, 19 hours, 10 minutes. June 27, 1929.

Non-stop Los Angeles to New York, 17 hours, 36 minutes, June 28, 1929.

Round trip New York to Los Angeles to New York, 5,000 miles 36 hours, 46 minutes flying time, 42 hours, 48 minutes elapsed time.

First transcontinental glider flight, San Diego to New York, 2,800 miles. Tow plane Texaco 7, J. D. (Duke) Jernigin, Jr., pilot. Glider Texaco Eaglet, Captain Frank M. Hawks, pilot. March 30, April 6, 1930.

New York to Los Angeles, via Columbus, St. Louis, Wichita, Albuquerque, Kingman, Ariz., 2,500 miles, 14 hours, 30 minutes, 43 seconds, August 6, 1930.

Los Angeles to New York via Albuquerque, Wichita, Indianapolis, 12 hours, 25 minutes, 3 seconds. August 13, 1930.

New York to Detroit 640 miles, 3 hours, 5 minutes. Sept. 9, 1930.

Detroit to New York, 2 hours, 41 minutes, Sept. 30, 1930, world record for speed and distance.

Boston to New York, 193 miles, 53 minutes, October 7, 1930.

New York to Philadelphia, 90 miles, 24 minutes, October 8, 1930.

Philadelphia to New York, 20 minutes, October 8, 1930.

New York to Havana, 1,400 miles, 9 hours, 21 minutes, November 7, 1930.

Havana to New York, 8 hours, 44 minutes. November 9, 1930.

New York to Nashville, 800 miles, 5 hours, 15 minutes, Dec. 3, 1930.

Memphis to Atlanta, 455 miles (wide route), 2 hours, 20 minutes. December 6, 1930.

Washington to New York, 220 miles, 58 minutes. December 9, 1930. (Broke own record.)

New York to Washington, 1 hour, 5 minutes, December 15, 1930. (Broke own record.)

Fort Worth, Texas to New York, 1,400 miles, 8 hours, 30 minutes. January 25, 1931.

After this transcontinental record was taken from him, Hawks remained comparatively out of the aviation spotlight until June 27, 1929. On that date, flying alone and in the same high wing monoplane in which he established his first record, he traveled non-stop over the 2,700 miles from New York to Los Angeles in 19 hours, 10 minutes, and on the following day he returned non-stop in 17 hours, 36 minutes. He had gone from coast to coast in 36 hours, 44 minutes, which gave him the cross-country laurels east and west, and also the round trip record.

These records continued to stand even after Colonel Roscoe Turner of Los Angeles, traveling westward, and Lindbergh, traveling eastward, bettered the times for them through the advantage of making a gas and oil stop midway at Wichita, Kansas and so flying with a fuel load comparatively far lighter than those carried by Hawks. *The non-stop Hawks' records continue today to be recognized by the National Aeronautic Association, the governing body for aviation in America, but the popular belief was that Hawks had lost his laurels.*

As in the case of loss of his first transcontinental record, Hawks, however wasted no time to redeem what Turner and Lindbergh had taken from him. In

the spring of 1930, he personally supervised the construction of a low-wing monoplane capable of a high speed of approximately 250 miles an hour, and in August of that year he flew from New York to Los Angeles, making refueling stops at Columbus, Ohio, St. Louis, Wichita, Albuquerque, N. M., and Kingman, Ariz., in 14 hours, 30 minutes, 43 seconds. A week later he returned via Albuquerque, Wichita, and Indianapolis in 12 hours, 25 minutes, 3 seconds.

These flights, especially the return trip, identified his craft, the Travel-Air mystery ship "Texaco 13," as the fastest commercial airplane in the world, and Hawks as the speediest airman. No airplane or no pilot except those in the International Air Races, which took place over a naturally short race course, had ever traveled as fast. Subsequently Hawks flew his winged torpedo between scores of American and Canadian cities, establishing informal records between many of his take-off and landing points.

(Continued on page 1)



# ALL ABOARD, MODEL TRAINMEN!



Edwin P. Alexander and his Penn-Eastern System (Westchester Photo)

**F**IFTEEN years ago Edwin P. Alexander became interested in what he considers the grandest hobby of them all, the making and operation of model trains.

Today at twenty-five he is still an enthusiast, and when I learned that in his home at New Rochelle he has what is one of the most complete model rail systems and manufacturing plants in the world, I thought that you might like to take a run up there with me and look things over. So that all of you can be let in on the trip, we'll make it through the pages of Model Airplane News.

Come with me to the big house at 30 Avon Road. It has to be a big house, and you'll learn the reason when you see the basement and the attic; both specially designed last year when the house was built.

Alexander meets us at the door. He is a tallish young man, in sweater and knickers, with a pleasant grin. "Come on downstairs and we'll look at the works first," he says.

Here is a big basement, with plenty of light streaming down from windows at either end. Two assistants are busily preparing parts for model cars, and assembling the various bits of brass, copper, wood, aluminum, and steel which make up a model.

All along one wall runs a long workbench for assembly. Here is a lathe for turning out the engine parts, by far the most difficult and complicated part of the work. Here are stack on stack of templates, wooden car-roofs, strips of cardboard for the sides, with windows already punched. Along another wall are thousands of boxes, each containing its special wheel, truck, or coupling. Here is a wide workbench, heaped with blue-prints and locomotive plans. The charm of this type of model-making is that everything is absolutely to the scale of one-quarter inch to the foot; and actual plans of cars and engines, secured by courtesy of the Pennsylvania and other big roads in this country and abroad, are used in making up the models.

However, all this raw material, interesting as it is, doesn't tell the story to most of us who are novices at the model train hobby. Alexander then leads the way over to a fourth corner, behind the stairs. Here are his early models, some made when he was just beginning. Here also are old-fashioned models, English trains, and a complete station made of tin. Here also is a complete collection of foreign ship models, some of them in miniature so fine that it would seem to be a job for a watchmaker to put them together, rather than a model-maker. But all this is kept only that Alexander can show his progress in the work, and observe what they are doing on the other side. England, for instance, is still very enthusiastic over model-trains, and nearly every town has its model-makers club of boys and men.

Coming toward the stairs again we have to climb around the ten-foot model of a tunnel entrance, complete with tracks, trains, and scenic effects, which Alexander is making for an exhibition. We pause a moment to look over one of the assembly sets, ready to go out to a boy somewhere, maybe on the other side of the world. It happens to be for a tank car, which is one of the cheapest and easiest assembly sets, and which adds a realistic effect to any model freight train; a necessary part of the system.

You might like to look over the parts with me, and find out just what a boy starts with in making one of these accurate scale models. There is, first of all, a blue print. That is the big thing about model-train making—you work just as a car factory would work, scientifically and accurately.

Then there are eight inches of tubing, a set of truck parts, a pair of saddle castings, a dome, a pair of ends, and eight handrails. There is nothing in the original tank car which is not provided for in the model set. Here is a brake cylinder with screws; there a 24" handrail, bent and in one piece. Here are two running boards, and ladder parts. Then

Take a Trip  
to  
Miniature Railwayland  
With  
**THEODORE ORCHARDS**



there are thirty-six brass pins for binding securely, one brake wheel, two upper running boards, wire, safety-valves, and a pair of automatic style couplers, with tubing.

A flat car is even simpler to make, using only eight or nine separate parts. Any boy can assemble one of these in an afternoon. For this model, you need only the blue print, a pair of sides, a floor, a set of truck parts, two end pieces, two brake wheels and rods, and the usual trimmings of washers, couplers, handrails, and steps.

Alexander tells us why there is such a complete stock of parts in the "O" gauge, which is by far the most popular style among railroad-minded boys and men. The reason is because "O" gauge is to the scale of  $\frac{1}{4}$ " to the foot, the largest size practical to make, since it requires a three foot minimum radius for curves. A larger gauge is useful only out of doors, where space is not a problem, and then of course the drawback is that one cannot work at it in the winter, or at night, and of course weather is hard on tracks and trains.

The "OO" gauge is a novelty in the extreme miniature size, but its smallness does not lend itself to working in perfect scale, and fewer parts and engines are available for it. The reverse would apply to the large gauges, more than an inch between rails, for here detail becomes everything, and only those who care more for making rolling stock than for running a train system go in for these sizes. All in all, "O" gauge is by far the best for the average boy to start on. Alexander's own beautiful system is built in "O" gauge . . . but you'll hear more about that later.

On the way upstairs we pass Alexander's office and library, truly a wonderful place for any boy or man who gets a kick out of railroading and trains. The books all deal with the various problems of trains and railroad systems. There are histories of railroading; hundreds of volumes on construction and design; on famous engines and their exploits; and on some of the big men, the unsung heroes, of the business.

Here are photographs of practically every railroad system and every train that ever existed, from the first puffy little stem-boxes that pulled carriages on a track to the crack flyers of today.

In the office are heaps of letters from model-makers and fans all over the world; from Australia, New Zealand, Africa, China, Peru, and Alaska. Somewhere in between his other activities Edwin Alexander answers this host of queries . . . don't ask me how. He'd probably answer you if you wrote to him, provided your interest in his great hobby is sincere and serious. But don't say I told you.

However, we can't linger long in an office when the railroad yards are waiting for us, up in the wide attic. So come on, let's get up there and look it over.

Above, Miniature Wrecking Crane in Operation

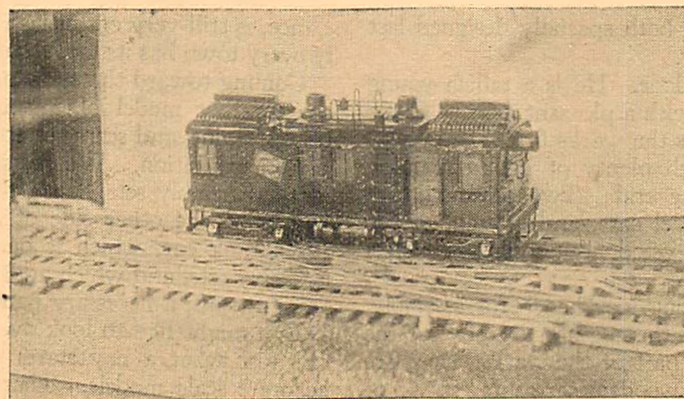
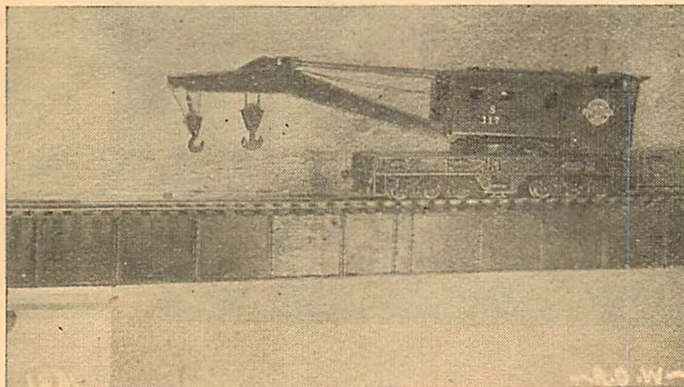

"It never will be finished, any more than a real system is finished. There will always be some new improvement to install, some new signals or a new development in rolling stock, roadbed, or switches and terminals. What you see here represents only a few months' work, and you must understand that this is still railroad construction, and not yet actual operation of the model line. That will come next fall, with good luck. It will take that long to complete the mountain division, and get the terminal in shape. Let us show you something. . . ."

"Something" is right! As he speaks, Alexander leads us into the attic room. We come up almost in the center, and around us in a great oval which approximates twenty by forty feet lies the "Pen-Eastern" right of way, main line double tracks laid, switches complete, and signals working.

We come first to the yards, near which the round-house is already partially constructed, with a turn-table in place. Here is the signal tower, and here, therefore, is the controlling unit; the brains of the system.

Alexander presses a button and sets a couple of tiny levers in an open-top tower. Then his fin-

gers touch a locomotive, and we watch as she picks up speed, dragging a dozen passenger cars down off the side-track, under the tower, and onto the main line.

At the touch of the power lever current goes full on, and the wheels fly and pistons plunge as the train swings past the round-house and yards, around the curve, and roars down the main line. There is a clickety-click of the rails and a familiar roar as the train takes the curve at the far end of the room, in front of the large windows, and then comes swinging around toward us again.

We can't help leaning over, as Alexander does, with our eyes a few inches from the track, to watch the approaching model. Then, strangely enough, it is no longer a model. It is a roaring Pacific-type locomotive, crashing along at sixty miles to make schedule. We forget for a moment that a touch of our fingers would derail it, and duck back in time to save ourselves. Alexander laughs. "Everybody feels

that way," he comments. "That's why I like model trains."

This time, however, Alexander sends out two trains from the yards, and then four. The room resounded with the click of the rails, and we began to fear a wreck. "Impossible," says Alexander. "Look over there."

A light flashes red-green on the signal tower, and the locomotive slows up and stops. "Automatic safety device," says Alexander. "The line isn't clear. This is the same complicated system of remote control and signals used by the big lines during the last few years." He touches a lever in the tower, and the train gets under way, pulls out of the yards, and speeds merrily on its way. The others pull into the Model Milwaukee Electric yards, and are side-tracked.

Locomotive in Action (below)

"Watch that passenger train,"

"It's not finished," Alexander warns us as we come up the stair.



we are told. "I've sent it up on the mountain division. The track is complete only part of the way."

This mountain division is built at a higher level than the main line, with a sharp grade. Eventually it will be done in scenic effects, with tunnels, mountains, horse-shoe curves, and even a suspension bridge!

The engine puffs sturdily as it hits the grade, which is exactly the per cent of grade possible in actual practice, and finally manages it without the help of an auxiliary engine, as is often used in the Rockies. It races along, level with our eyes, until we hold our breath for fear it will plunge off the gap where the suspension construction has been begun. But no, the current is cut off and the train stops.

This engine, like most of those made by Alexander and his associates, is of the steam type, and looks exactly like a steam locomotive. However, it uses electricity for power in a concealed motor, for while steam-driven locomotives are entirely possible and work, yet they are not, naturally, as easily managed, and the real effects cannot be achieved with them.

The train is reversed. It is switched from one line to another, cut under a side-track for coaling and for water, and eventually runs back into the yards. Then Alexander gives us an example of switching, using a smaller sturdier engine for this hauling, and breaks up the train. The Pullmans go on one track, the coaches on another, dining-car here, private car there.

Then he sends the locomotive around the main line again, giving her full speed. On the far curve, under the window, the bouncing engine seems to run wild and leaves the rails plunging on her side.

"She always does that on the curve," we are told. "That is what would happen to an engine in actual practice which ran wild with no hand at the throttle on a curve. Here is why I did it, however."

From a sidetrack which we have not noticed before there moves a worktrain, consisting of a freight engine, coal tender, two freight cars. What's this? Instead of a caboose, there rides behind a perfect wrecking crane, so complete that we rub our eyes to see if perhaps we haven't grown big, instead of the railroad small.

A little switching, during which the automatic couplers grab faithfully, and the wrecker is being pushed by the freight engine around the main line, until at last it pulls up to where the wrecked locomotive lies, its wheels still spinning slowly. With the very slightest assistance from the wrecking crew, which happen to

A Realistic View of Mr. Alexander's System (above)

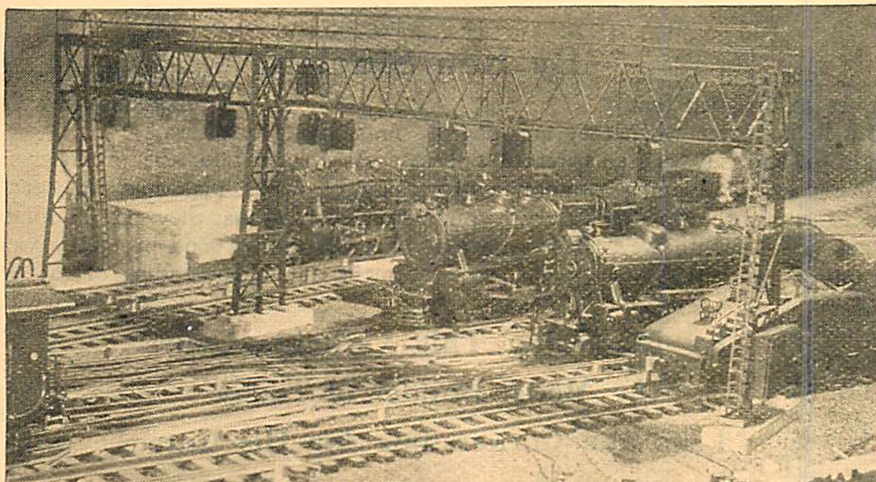

catch the wrecked engine.

The pressure of a finger at the rear of the wrecker, and good old number 906 comes up out of the ditch, and finally is set down on the rails again. The crash has been a slight one, for she moves along to the yards under her own power.

So much for the system in its

present state. There are plans of stations to be added, complete shops, more signal towers, coaling stations, and a terminal station and bridge. Perhaps the main terminal station will be landscaped, all in scale, to fit in with a tank for a model steamship, and a landing field for tiny scale model planes. Of course, since everything in the Alexander system is  $\frac{1}{4}$ " to the foot, the planes will be much smaller than those in common use among model builders today.

Alexander is not interested in his own system only, or in the business which has grown out of his model-making. He tells us at some length about the great model system up in Greenwich, Connecticut, which is the only one he knows that is larger than his own. It is set in a large building, and represents an investment of about thirty-five thousand dollars. The builder, Minton Cronkhite, is another of the great army of model fiends. Incidentally, Alexander has built many of the cars which spin over the Cronkhite system.

Vincent Astor, at his country place at Rhinebeck, New York, has a system out of doors a mile-and-a-half long. This, however, is to the large scale of three-and-a-quarter inches to the foot, and will bear the weight of a man.

All over the world there are located similar fans with similar systems, most of them far less elaborate and costly, of course; but each one of them providing thrills and, incidentally, a valuable mechanical education for both boys and men. Indeed, many of the greatest model-

train fans are railroad men themselves!

Edwin Alexander knows his subject and he loves his work with models. A few weeks ago a newspaper reporter asked him why he took up model-trains in the beginning.

"My father is a designer," said Alexander, "and that started me, at the age of ten, on making models. Not toys, but real scale models that work. For fifteen years I've been in it. Railway models not only resemble the actual rolling stock, the actual items of a railway system, but they may be operated just as successfully from a mechanical and scientific standpoint.

"You can take photographs, even moving pictures of a model train in operation, and if the background is natural it will be almost impossible to distinguish (Continued on page 42)

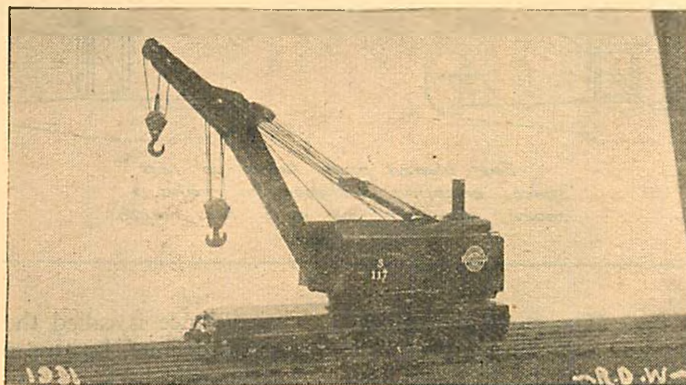

Another View Showing How a Wrecking Crane Works (below)



# A Course in Airplane Designing

By Ken Sinclair

**T**HE airplane is sustained by its wings, which are so designed that they produce a lifting force when they are moved through the air. There can be lift, therefore, only when the ship is moving and we employ a motor, acting through a propeller, to supply the force necessary to pull or push the ship along. This month we shall learn what we can about the propeller.

Essentially, a propeller is nothing more than a pair of wings, set at the proper angles, and attached to an axis so that they may revolve. Their action is precisely the same as that of the usual wings; that is, they produce a "lifting" force by moving through the air at a suitable angle of attack. The motor

moves them through the air, and they provide the force by pushing back against the air, much as a swimmer pushes back against the water when he goes forward, and exactly as the propeller of a boat pushes against the water.

There is nothing complicated in the basic idea of the propeller, or "airscrew." The first successful model airplane that I built had a propeller that consisted of a block of wood, which was the hub, and two rounded pieces of cardboard which were glued into slots in the hub, being set at an angle.

The propeller proved quite satisfactory, for that time, until

one day I flew the ship in a fog. The moist air softened the glue and one of the blades was soon thrown off by the centrifugal force. Then the ship proceeded to shake itself to pieces due to the unbalanced prop.

From that simple and relatively inefficient propeller it is seemingly a long story to the carefully made props of today; and yet those of today are merely refinements on the original principle. We model builders, you know, must

fairly thrive on refinement of design. The distance and duration records of our ships are due in a very large measure to refined and efficient design. In other

By Mastering This Valuable Course,  
the Model Builder of Today  
Lays the Cornerstone for His Career  
as the Aeronautical Engineer  
and Designer of Tomorrow

words, they are due to careful planning for minimum weight and drag, and maximum flying qualities.

As I have said, the propeller is nothing more than a pair of wings, placed at the correct angles and attached to a shaft so that they may be rotated. However, we can't expect to build good propellers working blindly and without a full understanding of the principles involved. We

have to know the how and why of a thing before we can do that thing well. Let's see what we can learn about the how and the why of propellers.

The underlying idea of the whole thing is that of the screw. Dropping airplanes for the moment, we take up the simple wood-screw, the

kind that we used to make that cabinet or that table the other day. Take a good look at a wood-screw. See how it works? The thread is a spiral arrangement and it cuts

into the wood, pushing back against it as the screw is turned, thereby pushing itself forward. That is the basic principle, centuries old, that is applied in the airplane propeller.

The screw moves forward by pushing back on the wood. That is true whether the person turning it is applying any pressure on the screwdriver or not. Furthermore, the screw moves a certain definite distance with every full turn it makes.

This distance is called the pitch. The pitch of a wood-screw is definite, because the wood is a solid medium and does not slip back.

The same is not true, however, of the airplane propeller or of the boat propeller. In the latter cases, the medium in which the screw operates is fluid and moves backward as the screw pushes it. The amount that it moves backward is called the slip, and may easily be seen in everyday

practice as the slipstream from an airplane propeller or the propeller wake of a boat.

If possible, watch a boat some-  
(Continued on  
page 47).

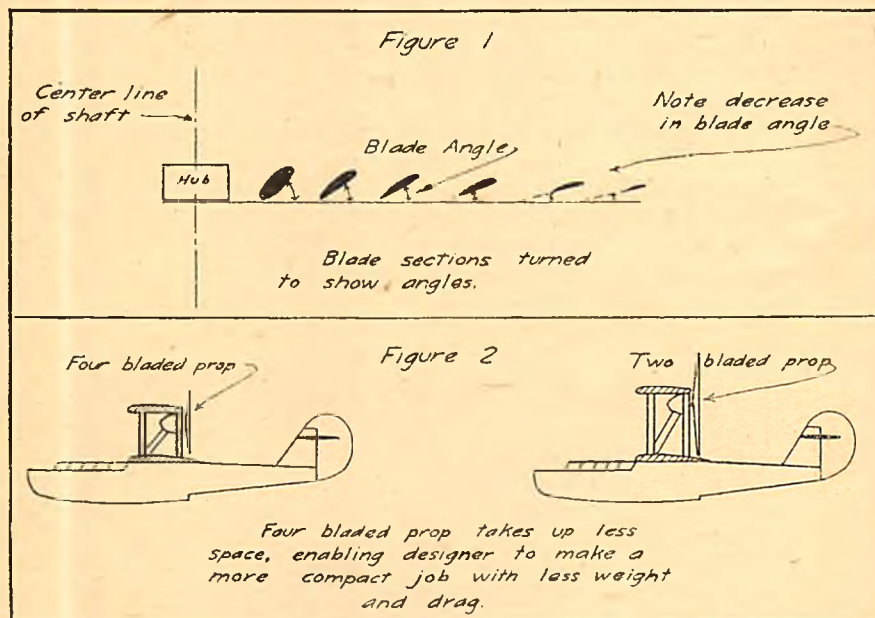

**I**N presenting this course, MODEL AIRPLANE NEWS wishes to stress the fact that model building is more than a mere sport. If the builder of model airplanes learns the fundamental principles underlying airplane flight and design, he prepares himself for a future career in the most profitable phase of aviation.

The policy of MODEL AIRPLANE NEWS is not to encourage or teach its readers to become pilots, but rather to become aeronautical engineers, designers, salesmen, manufacturers, or equip themselves for any other positions which require the training of the specialist or executive. Study this course from month to month, master it in every detail and you will gain a fundamental knowledge of the how and why of airplane design which will be second to none.

THE EDITOR.





# AVIATION

Conducted by

**O**UR readers seem to feel as we do that the subject of how the government regulates aircraft in flight is a fascinating one—so in response to the demand we are publishing in detail all you want to know about air traffic rules.

The Air Traffic Rules form chapter 7 of the Air Commerce Regulations of the Department of Commerce. All civil and commercial aircraft, licensed or unlicensed, must conform to these rules at all times, whether flown privately or engaged in interstate or intrastate commerce.

## SEC. 70. LAW.

"The Secretary of Commerce shall by regulation establish air traffic rules for the navigation, protection, and identification of aircraft, including rules as to safe altitudes of flight and rules for the prevention of collisions between vessels and aircraft." (Air commerce act of 1926, sec. 3 (c).)

## SEC. 71. UNLAWFUL ACTS.

"It shall be unlawful . . . to navigate any aircraft otherwise than in conformity with the air traffic rules." (Sec. 11 (a) (5).)

## SEC. 72. PENALTY.

"Any person who violates any provision of subdivision (a) of this section . . . shall be subject to a civil penalty of \$500. (Sec. 11 (b).)

## SEC. 73. APPLICATION OF THE LAW.

"In order to protect and prevent undue burdens upon interstate and foreign air commerce the air traffic rules are to apply whether the aircraft is engaged in commerce or noncommercial, or in foreign, interstate, or intrastate navigation in the United States, and whether or not the aircraft is registered or is navigating in a civil airway."

(Statement of managers accompanying conference report, air commerce act of 1926.)

## SEC. 74. FLYING RULES.

(A) *Right-side traffic*—Aircraft flying in established civil airways, when it is safe and practicable, shall keep to the right side of such airways.

# BOARD



# ADVISORY

Capt. H. J. LOFTUS-PRICE

(B) *Giving-way order*—Craft shall give way to each other in the following order:

1. Airplanes
2. Airships
3. Balloons, fixed or free

An airship not under control is classed as a free balloon. Aircraft required to give way shall keep a safe distance, having regard to the circumstances of the case. Three hundred feet will be considered a minimum safe distance.

(C) *Giving-way duties*—If the circumstances permit, the craft which is required to give way shall avoid crossing ahead of the other. The other craft may maintain its course and speed, but no engine-driven craft may pursue its course if it would come within 300 feet of another craft, 300 feet being the minimum distance within which aircraft, other than military aircraft of the United States engaged in military maneuvers and commercial aircraft engaged in local industrial operations, may come within proximity of each other in flight.

(D) *Crossing*—When two engine-driven aircraft are on crossing courses the aircraft which has the other on its right side shall keep out of the way.

(E) *Approaching*—When two engine-driven aircraft are approaching head-on, or approximately so, and there is risk of collision, each shall alter its course to the right, so that each may pass on the left side of the other. This rule does not apply to cases where aircraft will, if each keeps on its respective course, pass more than 300 feet from each other.

(F) *Overtaking*—(1) *Definition*—An overtaking aircraft is one approaching another directly from behind or within 70° of that position, and no subsequent alteration of the bearing between the two shall make the overtaking aircraft a crossing aircraft within the meaning of these rules or relieve it of the duty of keeping clear of the overtaken craft

until it is finally past and clear.

(2) *Presumption*—In case of doubt as to whether it is forward or abaft such position it should assume that it is an overtaking aircraft and keep out of the way.

(Continued on page 36)

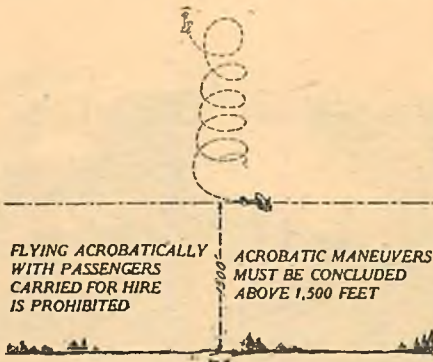

NO ACROBATICS IN THIS PROHIBITED SPACE



FIG. 11

NO ACROBATICS IN THIS PROHIBITED SPACE

NO FLYING LESS THAN 1000 FEET

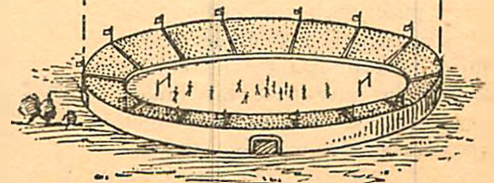

FIG. 9



# Wartime Models Return to Favor

WITH the current interest in building models of famous wartime airplanes, it is good news to find that firms supplying kits for such models have their authenticity at heart. What could be more disappointing, for instance, than finding 1930 markings on a 1914 model plane? And what could be more exciting than to know that one can actually find the real thing in kits for these old ships?

Admirers of Capt. Edward V. Rickenbacker, America's Ace of Aces, who has twenty-six official victories to his credit, will be glad to learn that plans and kits are obtainable of his famous Spad; of the Fokker D-7 (appearing on this month's cover), and of the Nieuport Scout and the Albatross C-3. The Albatross D5A, pictured on our March cover, was a later type; distinguishable by the tail skid from the C-3, which used a small triangular fin as a skid. Among the more important firms constructing these kits and plans is the Cleveland Model & Supply Co., whose experts are showing the way in accuracy of detail and general finish.

The model of Rickenbacker's Spad is colored just like its famous prototype—yellow wings and tail and light green fuselage. The famous "Hat-in-the-Ring" insignia is on the side of the fuselage with the numeral "1" which indicated that Rickenbacker was the leader of the 94th "Hat-in-the-Ring" Squadron. As you know, the symbolic meaning of the insignia was that this squadron, too, had thrown its hat into the fighting ring.

Thrills aplenty are found in Rickenbacker's Book, "Fighting the Flying Circus," and one incident is worthy of recounting. Shortly after Rickenbacker changed from the little Nieuport, in which he flew at first, to the Spad, he encountered eight Fokkers of the enemy. Immediately three Fokker D-7's swooped down on one of the two French photographing machines which his squadron of eight were protecting. One Fokker was so intent on getting the pilot of the photographing machine that the escort of Spads was ignored. Rickenbacker knew that he must act quickly. He was in exact position to meet the D-7 and, at the right moment, he pulled his machine straight up on her tail, trained his sights along the line of his dive, and began firing. Here was a new trick!

As the Fokker came diving down, the bullets from Rickenbacker's plane cut a straight streak of fire up and down its path, and as it came into line, it was ripped from stem to stern. Controlling his Spad to keep pace with the enemy, the American ace got at least one hundred rounds into the Fokker before he saw that his bullets were missing. Riddled with shot, the Fokker dropped but did not

burst into flames.

Generally acknowledged as one of the superior fighting planes of that time, the coloring of the famous Fokker D-7 added a note of beauty to its war-riding capabilities. Its dark green wings and tail, orange fuselage and struts, were often a striking sight over the lines.

The Nieuport with yellow wings and tail, and black fuselage and struts, was flown by many famous pilots of the Allies. It was termed by them "plane-

and-a-half," rather than sesquiplane, the technical term used to denote a machine with a bottom wing half the size of the top wing.

Quite efficient in its time and the most beautifully streamlined job during the World War was the German Albatros C-3, with its orange wings and light blue fuselage and tail. It carried out features of streamlining far beyond the dreams of most designers of that day.

Agreeing with all model airplane enthusiasts that the colorful period of the World War deserves authentic reproduction for all time, the Cleveland Model & Supply Co., among others, has put its best engineering skill into designing these war planes, and they have succeeded greatly.

Excellent flights were obtained, many flying more than 200 feet in preliminary midwinter tests, which is known to be a poor time to test scale models

Despite the great progress in airplanes of today there is much of aerodynamics to be learned from the planes of yesterday—and what better method is there of following the evolution of aircraft than by building and flying models of such famous planes?

Examine an old model and then compare the construction and general attributes of it with a

present day model. See what little actual difference there is in the general design.

You will notice, of course, that today's airplanes are streamlined better than the older types, and also have better, larger and more powerful engines.

In building the older models you will be able to gauge the progress made in the wonderful industry of aviation since its enormous spurt of the war years, to the present careful and deliberate and virtually inexhaustible research in the same field to ensure above all safety in flight.

All credit for today's progress must go to those pioneers of days gone by who risked life and limb to prove theories which today are scientifically calculated before even the plane itself is built.

It is no wonder then, that the spirit of adventure which ruled the actions and hopes of the pioneers still lives in the desire of present day model airplane enthusiasts to learn all about and build famous models of other days.

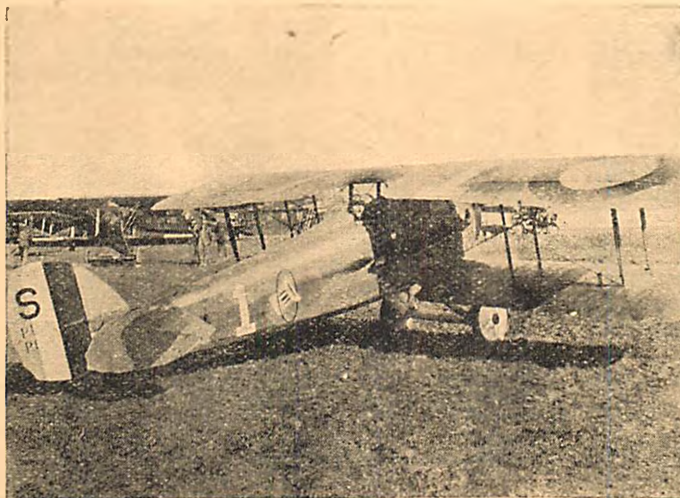

Capt. E. V. Rickenbacker in his famous Spad

## Youth of Today Delves Into Aircraft of Yesterday



# "Tale Spinning" With a Pioneer

## An Outline of the Model Airplane Building Career of Mr. I. Sturiali

**M**ODEL airplane engineers and experts of the present day will be interested in the reminiscences of a model builder who was active in the sport more than twenty years ago. In 1910 miniature airplane enthusiasts probably numbered fewer than two hundred in the entire world. Today the number is more likely a million.

What were the favorite models of those early days? What has become of the pioneers who built them?

One of the first model builders in the United States was an Italian—Mr. I. Sturiali. The story of this man, one of the founders of the model building movement in America, is truly remarkable.

Born more than fifty years ago in the little Italian city of Catonia, Mr. Sturiali says that he decided almost before he could walk, to devote his life to invention and mechanics. As he grew older this ambition became more and more firmly planted in mind, and at last he persuaded his parents to send him to the Scientific Institute in a neighboring city.

Although one of the youngest pupils ever admitted to the academy, Mr. Sturiali finished the entire courses on mechanics, physics, and chemistry in three years and received a diploma as a Naval Engineer soon after his twentieth birthday.

Almost immediately after his graduation Mr. Sturiali entered the Italian Navy—it was here his interest in aviation first began. Remaining in the navy for four years, he came to the United States in 1904. Here, anxious to learn still more about mechanical science, he entered the scientific classes of the Hebrew Technical Institute.

Soon opportunities to use his experience and knowledge appeared. Work in the Sperry Gyroscope Company's factory brought him to the attention of officers in the United States Navy, and he was engaged by them for mechanical work in the Brooklyn Navy Yard. There Mr. Sturiali again added to his steadily growing interest and information regarding the almost unknown science of aeronautics.

Some years later, in 1910, Mr. Sturiali's first real entry in the aviation field occurred. While foreman of a machinery factory in New York City he became acquainted with two young Italians who are now famous figures in American aviation, Johnny Carisi, constructor of the transatlantic airplane Columbia, and Vincent Burnelli, inventor

of the huge Burnelli Monoplane. The three young inventors, soon learning of their mutual interest in aviation, began to build models of "popular" planes.

A miniature reproduction of the "Bleriot," first heavier-than-air craft to cross the English Channel, was their first attempt, followed by replicas of the "Farman," a famous French plane, and the now forgotten "Antoinette."

Mr. Sturiali tells an interesting anecdote of his first original model. In 1912 the use of ailerons (movable flaps on the backs of a ship's wings) to control the vertical flights of airplanes had not been thought of, and wings were fixed to the fuselage in a permanent position, or "angle of incidence." Of course, such an arrangement was a great handicap to flight and Mr. Sturiali, in his next model set about improving this.

The experimental model was made entirely of reed, and had a wing spread of eight feet. Its unusual size was not, however, the really important feature. Mr. Sturiali, by means of a bearing, and a worn gear had attached his wings to the fuselage on a pivot, so that they might be placed at any flying angle desired. For the take-off the wing could assume a sharp upward angle, for horizontal flight the wings could be made level, and for the landing a downward tilt was possible.

By now the three young men had become the best customers of the only model supply shop in the entire country and were anxious to graduate to real airplanes. Mr. Sturiali's invention, although never commercialized, inspired the enthusiasts to make an actual airplane. With the permission of their employers, Sturiali, Carisi, and

Burnelli set up a shop in the factory where they worked. Months of steady labor, from six o'clock till midnight were rewarded at last by the completion of their ship.

Two problems confronted them. First, how to get the plane to a flying field?

Obviously it was too large to take through the streets in a truck. Reluctantly they decided to dismount the ship and reassemble it at the field. After this delay, the impatient pioneers found another and even greater difficulty confronting them: Not one of the three knew how to fly!

Pilots in those early days were hard to find. At last one was found. Next a long wait for favorable weather conditions. Rain

(Continued on page 40).

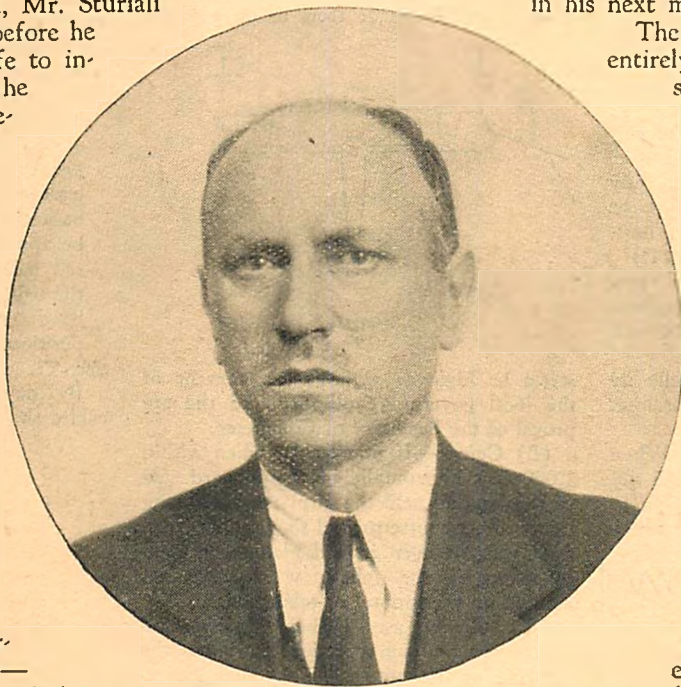

Mr. I. Sturiali



(Continued from page 33)

taking aircraft shall keep out of the way of the overtaken aircraft by altering its own course to the right, and not in the vertical plane.

(G) *Height over congested and other areas*—Exclusive of taking off from or landing on an established landing field, airport, or on property designated for that purpose by the owner, and except as otherwise permitted by section 79, aircraft shall not be flown—

(1) Over the congested parts of cities, towns, or settlements, except at a height sufficient to permit of a reasonably safe emergency landing, which in no case shall be less than 1,000 feet.

(2) Elsewhere at height less than 500 feet, except where indispensable to an industrial flying corporation.

(H) *Height over assembly of persons*—No flight under 1,000 feet in height shall be made over any open-air assembly of persons except with the consent of the Secretary of Commerce. Such consent will be granted only for limited operations.

(I) *Acrobatic flying*—(1) Acrobatic flying means intentional maneuvers not necessary to air navigation.

(2) No person shall acrobatically fly an aircraft—

(a) Over a congested area of any city, town or settlement. (Fig. 8.)

(b) Over any open-air assembly of persons or below 2,000 feet in height over any established civil airway, or at any height over any established airport or landing field, or within 1,000 feet horizontally thereof. (Figs. 9, 10 and 11.)

(c) Any acrobatic maneuvers performed over any other place shall be concluded at a height greater than 1,500 feet. (Fig. 12.)

(d) No person shall acrobatically fly an airplane carrying passengers for hire. (Fig. 12.)

(e) Dropping objects or things—When an aircraft is in flight the pilot shall not drop or release, or permit any person to drop or release, any object or thing which

**NO ACROBATICS IN  
THIS  
PROHIBITED  
SPACE**



FIG. 8

## Aviation Advisory Board

may endanger life or injure property, except when necessary to the personal safety of the pilot, passengers, or crew.

(J) *Seaplanes on Water*—Seaplanes on the water shall maneuver according to the laws and regulations of the United States governing the navigation of water craft, except as otherwise provided herein.

(K) *Transporting Explosives*—The transporting of any explosives other than that necessary for signaling or fuel for such aircraft while in flight or materials for industrial and agricultural spraying (dusting) is prohibited, except upon special authority obtained from the Secretary of Commerce.

### Sec. 75. TAKE-OFF AND LANDING RULES.

(A) *Method*—Take-offs and landings shall be made upwind when practicable. The take-off shall not be commenced until there is no risk of collision with landing aircraft and until preceding aircraft are clear of the field. Aircraft when taking off or landing shall observe the traffic lanes indicated by the field rules or signals. No take-off or landing shall be made from or on a public

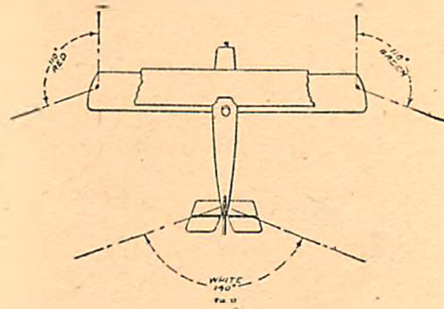

street or highway without the consent of the local governing authority and the approval of the Secretary of Commerce.

(B) *Course*—If practicable, when within 1,000 feet horizontally of the leeward side of the landing field the airplane shall maintain a direct course toward the landing zone.

(C) *Right over ground planes*—A landing plane has the right of way over planes moving on the ground or taking off.

(D) *Giving way*—When landing and maneuvering in preparation to land, the airplane at the greater height shall be responsible for avoiding the airplane at the lower height and shall, as regards landing, observe the rules governing overtaking aircraft.

(E) *Distress landings*—An aircraft in distress shall be given free way in attempting to land.

### Sec. 76. LIGHTS.

(A) *Angular limits*—The angular limits laid down in these rules will be determined as when the aircraft is in normal flying position.

(B) *Airplane lights*—Between one-half hour after sunset and one-half hour before sunrise airplanes in flight must show the following lights:

(1) On the right side a green light and on the left side a red light, each showing unbroken light between two vertical planes whose dihedral angle is 110° when measured to the left and right, respectively, from dead ahead. These lights shall be visible at least 2 miles.

(2) At the rear and as far aft as possible a white light shining rearward, visible in a dihedral angle of 140° bisected by a vertical plane through the line of flight and visible at least 3 miles.

(C) *Airship lights*—Between one-half hour after sunset and one-half hour before sunrise airships shall carry and display the same lights that are prescribed for airplanes, excepting the side lights shall be doubled horizontally in a fore-and-aft position, and the rear light shall be doubled vertically. Lights in a pair shall be at least 7 feet apart.

(D) *Balloon lights*—A free balloon, between one-half hour after sunset and one-half hour before sunrise, shall display one white light not less than 20 feet below the car, visible for at least 2 miles. A fixed balloon, or airship, shall carry three lights—red, white and red—in a vertical line, one over the other, visible at least 2 miles. The top red light shall be not less than 20 feet below the car, and the lights shall be not less than 7 nor more than 10 feet apart.

(E) *Lights when stationary*—(1) between one-half hour after sunset and one-half hour before sunrise all aircraft which are on the surface of water and not under control, or which are moored or anchored in navigation lanes, shall show a white light visible for at least 2 miles in all directions.

(2) Balloon and airship mooring cables between one-half hour after sunset and one-half hour before sunrise shall show groups of 3 red lights at intervals of at least every 100 feet, measured from the basket, the first light in the first group to be approximately 20 feet from the lower red balloon light. The object to which the balloon is moored on the ground shall have a similar group of lights to mark its position.

### Sec. 77. DAY MARKS OF MASTS, Etc.

By day, balloon and airship mooring cables shall be marked with tubular stream-

(Continued on page 1)

FIG. 8



2000'



CIVIL AIRWAY

FIG. 10



(Continued from page 20)

president, Philip Zecchitilla; Secretary, Alfred Huber.

The first meeting of the 1931 season took place in January with a large attendance. At this meeting a reception committee was formed, the duties of which will be to make new members feel at home and to look to the comfort of the visitors. The ordinary business of the meeting having been concluded an interesting talk was given by Capt. W. W. White, U. S. Army Reserve, chief test pilot for the Standard Oil Company of New Jersey.

He related the experiences that he and Lieut. McMullen had on their record breaking flight from Newark Airport to Buenos Aires, capital of the Argentine Republic.

Capt. White related how having obtained leave from the Army he set about preparations for his flight. The plane selected was a Lockheed and as the company insisted on a two-way radio being carried, he and his co-pilot had to brush up their knowledge in this branch. Preparations were carefully made, the route was mapped out. At that time landing fields were few and far between and the route finally selected left them with jumps of more than 1,000 miles.

The first hop was from Newark to Miami, which was covered in about eight hours, which constituted a record at that time, but which has since been beaten.

The next jump was to Panama about 1,200 miles over water, and then on to Honduras. Capt. White related how flying along the coast a dug-out canoe was sighted, the first sign of life they had seen in several hundreds of miles. Also, how

## American Sky Cadets

out in the ocean there are two "lumps of rock" called Swan Island, which they hoped to sight. On this island the United Fruit Company maintains a radio station during part of the year, but at that time it was uninhabited.

Sighting the island to their right they flew towards it congratulating themselves on being pretty clever navigators to hit so near a spot merely a speck in the ocean. However, on approaching nearer, their island turned out to be only a shadow of a cloud, which rather damped their feeling of elation. A little later they picked up the island and knew they were on their right course.

Part of their course lay over dense jungle with no open spaces to land on in case of emergency. Flying along later, in perfect weather, under a cloudless sky they suddenly saw ahead of them a dense bank of clouds. They had received previous warning that they would most likely meet with rain as in that part of the world, perhaps the wettest part in the world, it rains on an average of one inch per day.

Flying two or three feet above the sea and following the line of white which showed the coast line they carried on and suddenly came out of the darkness into brilliant sunshine, and then over desert country, arriving at Santiago on the evening of the fourth day out of Newark.

Their next obstacle was to be the Andes,

rising up over 20,000 feet. There was fog on the field but they received word from the station on top of the mountain that it was clear up there. The flying field authorities gave them their bearings and with Capt. White at the controls, they took off. A quick climb was essential, so the pilot gave her the gun. He told us of his co-pilot's worry, not knowing from his position and owing to the fog whether the ship was rising, falling or in a spin. Up, up through the fog they went shot out into a clear sky, hurdled the peaks and down the other side over Mendoza, San Luis and on over the Argentine Campus.

Arriving over Buenos Aires they found that although they had taken great pains to map out their course and make careful preparations for their take-off and subsequent flight they had not given a moment's thought to their destination. Buenos Aires they had thought of, if they had thought of it at all, as just a town.

In addition to this, though they knew the name of the landing field they had no idea where it was. However, they sighted one and flew over it, but found it was not the one they wanted. Circling round again they decided, as Capt. White put it, to look for the usual landmarks for a flying field—"open ground with a cemetery on one side and high tension wires on the other!" Circling around they spotted just such a place and sure enough it was the field where they were to land. A great reception awaited them and they had the satisfaction of knowing they had established a record for the flight from Florida for each stage of the flight from Miami to Buenos Aires which record still stands.

## AT LAST!

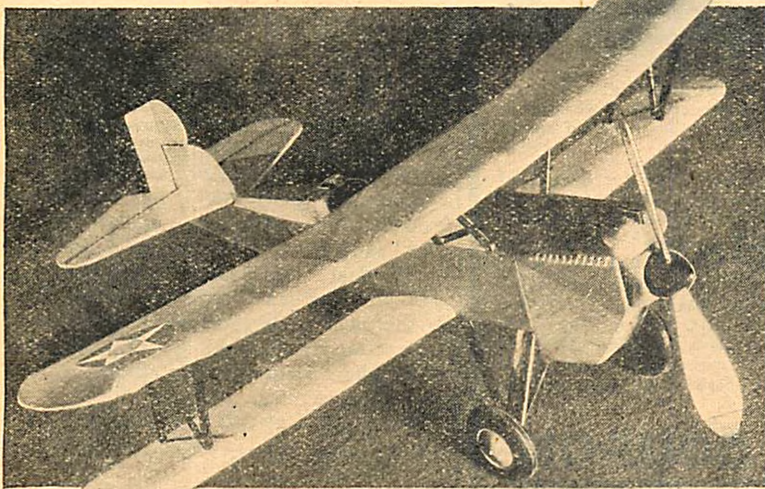

### FLYING GLORY

Most famous contest winner in the country. Wing span 27". Flying Glory models have flown 1500 ft. and are guaranteed for consistent flights of at least 300 feet. Kit contains everything, with many parts ready made. Prop ready carved. No cabin monoplane model like it anywhere for flying, durability and fine appearance. Kit \$3.75 postpaid.

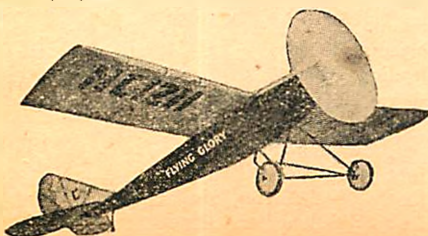

## A Guaranteed Flying Scale Model ONLY

**MODEL ENGINEERS!** We guarantee the Curtiss Falcon shown at left to be the finest Flying Scale Model Ever Produced from a commercial kit! Designed by I. Sturiali. The very plane you see illustrated was built by a 13 year old boy from one of our regular sets without assistance. You can easily do as good a job by following the simple full size diagram and instructions in the kit.

We guarantee that the correctly finished plane must fly 200-100 ft. or Your Money Back.

Capt. H. J. Loftus-Price, Editor of Model Airplane News, has personally flown and inspected the same Curtiss Falcon model shown here and certifies that it has his full approval and recommendation as to flying performance and accurate scale reproduction of the real plane.

Model has 17 in. wingspread, 3/4 ounce weight. Ribs, nose block, metal parts, radiator, slides, etc., are all either partly or entirely finished. Full size plans, celluloid wheels, extra dope, etc., included. You will be flying this model in 90 minutes after you receive your kit!

Get your Curtiss Falcon today for only \$1.95 postpaid. Immediate shipment.

**\$1.95**

### OPEN CONTEST!

We offer a beautiful silver cup with winners name engraved, for the best Flying Scale Model of a Curtiss Falcon. To enter contest model must have wingspread of not less than 17 inches and not more than 18 inches. No other rules. Any 17 or 18 inch model of the Falcon may enter. Nothing to buy, send in your own finished Falcon model, if you wish, or make one from the materials you already have on hand. Winner chosen for accuracy of scaling combined with flying performance.

Send or bring your model to Crescent Aircraft Supply Co., 1805 Benson Ave., Brooklyn, N. Y., by May 14th, closing date of contest. Decisions on winners given May 16th at Gimbel's Department Store. Models may be sent by mail and will be returned by May 23rd if return postage is sent.

Cup now on display, 5th floor Gimbel Bros. Start on your model today and win the cup with Your Name on it.

### CABINAIRE, JR. Kit \$1.00 P. P.

21" wingspan, 3/8 oz. cabin model. Indoor or outdoor flyer. Two minute endurance. Prop finished. Cellophane windows, adjustable wings, R.O.G. or hand launched. All balsa kit, with assembled landing gear and spars, wing edges, etc.,

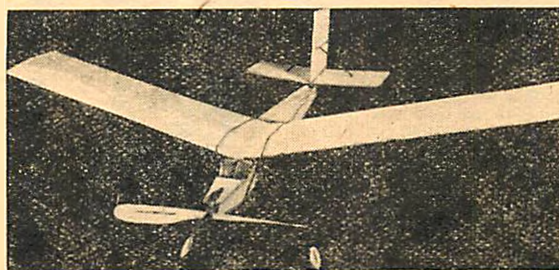

cut to size. Must fly or Money Back. Building time 1/2 hour. Kit \$1.00 or sent ready to fly for \$2.50. This company specializes in flying cabin models and accurate scale models that fly. Prompt, careful shipment on all orders. Watch for our future announcements of flying scale models of Curtiss planes.

## Crescent Model Aircraft

1805 BENSON AVE.  
BROOKLYN, N. Y.



# The Bowlus Sailplane

(Continued from page 21)

nana oil should be used for pasting. Then cover the wings, the tail, etc. Give one coat of banana oil to each covered surface and put away to dry.

Some of you builders may want to paint your ship. Silver powder mixed with banana oil can be used as a dope and paint at the same time. One light coat is sufficient.

The wing mount is now glued to the exact center of the center section. Meanwhile glue stabilizer and rudder in position, then attach the wings to the center section, making sure that the wings are perfectly balanced.

## GLIDING AND LAUNCHING

To glide the model, attach the wings to the fuselage by means of a rubber band. This is slipped around the fuselage. Place the wing where you think it balances best. Now draw the band over the top of the center section and under the fuselage. Try gliding the model indoors first. It should easily sail the whole length of the room.

Now take your sailplane outside. Choose a hilly or mountainous terrain (real mountainous land is not necessary) as these localities are better for gliders, due to the changing air currents and winds. By shifting the wings you will find the best gliding angle. Then give it its final flight, launching into the wind. When you are sure you have found the best position of your wing for gliding, you may discard the rubber band and glue the wing mount directly on the top of the fuselage.

Another method of launching can be duplicated by following the sketch shown here. Strong cotton with a fair sized loop tied at one end and slipped on to the nose hook will make it possible to launch the model like the real sailplanes. The length of the cotton can be either 150 or 200 feet.

Place the glider on a patch of level ground. Now walk out until the "shock cord" is straight. Then face and run into the wind and the model will begin to rise. If it tends to bank to the left, run a little to the right to level it out. If it should bank to the right, do the opposite. As soon as the glider gains sufficient altitude to suit you, cease running.

The glider will then slip from the loop and the sport begins. The sky's the limit!

## NECESSARY MATERIALS

- 1 piece, 1/32" x 2" x 18", balsa, fuselage formers
- 4 strips, bamboo, fuselage, etc.
- 3 pieces, 1/32" x 2" x 18", balsa, tail and wing ribs
- 1 block, 1 1/2" x 1 1/2", balsa, nose piece
- 1 piece, 3/4" x 1/2" x 2 1/2", balsa, wing mount
- 3 pieces, 1/16" x 3/8" x 12", hard balsa, leading edge
- 2 sheets, Japanese tissue
- 1/2 oz. can, ambroid
- 1/2 oz. can, banana oil
- 1 foot, wire No. 9
- 1 foot, 1/8" diameter, aluminum tubing
- 1 foot, 1/8" diameter, dowels

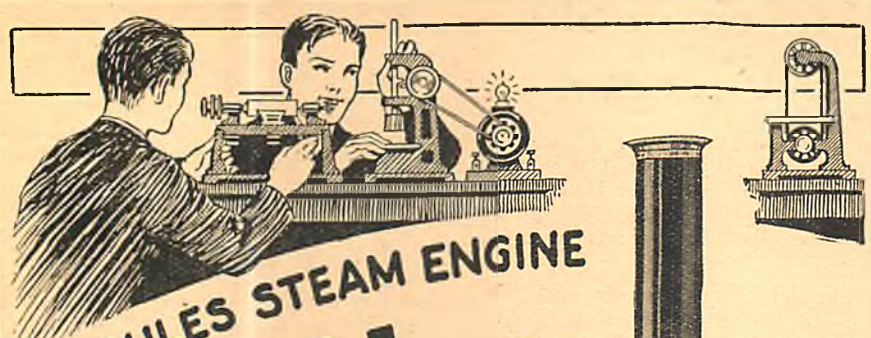

# HERCULES STEAM ENGINE GIVEN

## Very Special Offer

Here's a wonderful offer. "Little Hercules" special steam engine. Made by "Weeden," world's leading maker. This engine is of fine quality and highly finished in bright colors. Has heavy fly-wheel, smooth-running pistons and heavy cylinder. Strong boiler and fittings. Large fire box. Pulley wheel that will run mechanical toys like Erector, Meccano, etc. Runs on alcohol or canned heat. A big, POWERFUL, high-quality, steam engine. Just what you've been waiting for—and you can have it FREE! Read special offer.



## SENSATIONAL STORIES

The *Open Road for Boys* is a 50-page boys' magazine just crammed brimful of thrills. The kind of blood-stirring stories you've been looking for. Tales of high adventure on land and sea. Air stories that take your breath away, of war pilots in deathly combat above the clouds, of mail pilot heroes. Sport stories, school stories, tales of distant jungle lands, etc. No other magazine has stories like these. Best joke page published. World-wide correspondence club, friends in foreign lands, stamps, boy mechanic, tells you how to make all the things you want, OPEN ROAD PIONEER CLUB; best dope on hunting, fishing, camping. Contests galore with prizes for all. Extra money. One whale of a magazine say 200,000 readers. Red blooded stories for red blooded boys. Read special offer.

**Special Offer** Regular subscription price to *Open Road for Boys* is \$1 a year, (half of others). To make new friends we will send you the magazine for a whole year, twelve fat issues for \$1—and send you this wonderful steam engine FREE. This is a great offer. Act quickly.

## Ask Dad Now

Don't wait. Get your steam engine and have your fun right now. Ask Dad. He'll tell you Weeden means top quality and he'll tell you what a grand offer this is. Send coupon today. Back comes your steam engine and your first thrilling issue of the *Open Road for Boys Magazine*. You'll be greatly pleased with both steam engine and magazine. Satisfaction guaranteed or money back.

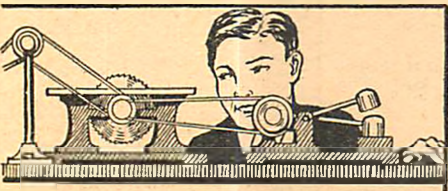

## USE COUPON

Canadian Postage 25c extra. Foreign 50c extra.

Open Road for Boys Magazine—Dept.  
130 Newbury Street, Boston, Mass.

Friends: Here's my dollar (\$1). You bet I want to grab this offer! Rush my steam engine to me and put me down for a year for the *Open Road for Boys Magazine*.

Name .....

Street .....

Town or City..... State.....





(Continued from page 8)

be drawn and the bearings plotted in reference to this. Having taken as many bearings as the time permits—at least four should be taken if possible—an equal number of convenient distances should be marked off on the edge of your ruler or protractor. This should be placed on the bearings plotted so that the points marked coincide with points on the bearings drawn.

Sometimes these equally spaced marks cannot be made to coincide exactly with all the bearings, and the position where most points coincide should be selected. In Figure III, for example, six bearings have been taken at equal time intervals on an object A. Assuming three-quarters of an inch is chosen as a suitable interval at which to space the points on the bearings plotted, the line BCDEFG will result and will indicate the direction of your track.

You will notice that all these points are not equally spaced, but that the majority are. Had half an inch been chosen as the interval, the line HIJKLM would have resulted, and as can be seen from the diagram, this line is parallel to the first. From this it will be seen that there can be only one direction for the ruler to lie if the distances are equally spaced.

Do not confuse this line with a position line. This line will only indicate the direction of your track, not the position of it, and of course its bearing will be measured with reference to the same line from which you plotted the bearings.

To ascertain groundspeed it is only necessary to obtain two pin-points on a map or a chart—the method by which they are

### Course in Air Navigation

obtained is immaterial—and note the time taken to travel this distance. The ground-speed is then readily calculated. There is also the method by which, with the aid of a stop watch, you observe the time taken for an object to pass between two beads in the drift wire. With the aid of tables in which reference is made to airspeed and height, the groundspeed is easily calculated.

#### LAST MONTH'S ANSWERS

1. Without the accurate knowledge of windspeed and direction, or drift, from which the first two can be calculated, no exact course can be plotted. The knowledge of windspeed and direction is one of the most essential features of air navigation.

2. See Figure IV. From point A draw a line, 90 miles to scale at an angle of 35°, to point B, and from this point draw another line at an angle of 9° to a suitable length. This represents your drift on this course but remember the port side, for the purpose of this method, is regarded as you look back towards the place of departure. From point A draw another line, 90 miles to scale and at an angle of 90°, to point C. This gives your second course, and from here draw a fourth line at an angle of 20°. Name the intersection of these two drift lines as point D and connect this with point A. Line AE now gives you the windspeed and direction, in this case from 180° at 33 miles per hour.

3. See Figure V. Repeat figure IV and from point A draw a line representing your third course, 90 miles to scale at an angle

of 155°, to point E. From here draw a line at an angle of 10°. The three drift lines converge as shown to form a small "cocked hat" at point D. A line drawn from the centre of this to point A indicates your windspeed and direction and proves the results of your first two courses.

4. (a) With the drift indicator set at zero, fly on a course until objects on the ground are seen to be passing along the drift wire, taking care that this course is upwind and not downwind. A glance at the compass will give you the direction from which the wind is blowing. This will be a compass bearing.

(b) Windspeed 31 miles per hour.

5. See Figure VI. Draw line AB any distance at 315° to represent wind direction. Next draw line AC 90 miles to scale at an angle of 225° representing your course crosswind, and then draw further line AD any length at an angle of 250° and this will be the direction of your track. (Course 225°+25° port drift.) From C draw a line parallel to AD until it intersects the line AB at point E. The distance AE measured to scale shows a windspeed of 42 miles an hour which agrees with the figure given in the table.

#### THIS MONTH'S QUESTIONS

1. Describe briefly how you would use drift markings on your main wing in finding your angle of drift. What are the essential points to observe in the use of this method?

2. How would you obtain a tailbearing over sea and land?

3. Explain briefly method 5 and the circumstances under which you would use this method.

### STINSON JUNIOR

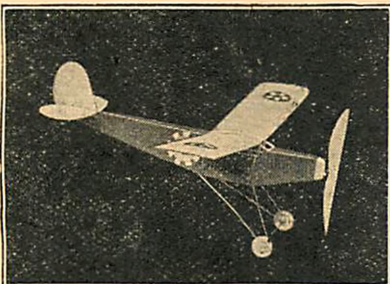

Kit set contains all necessary parts, ribs cut to size, blue print and wheels. Flies 1½ minutes, easy to build from blue print. Price for complete Kit \$1.50, Post-paid.

#### CELLULOID MOTORS

9 cylinder dummy whirlwind motors like cut, 3 inches in diameter and very light.

Price ..... 65c  
Postage 5c Extra



#### "THE ENTERPRISE"

6 full size sheets of blue prints to build the WORLD'S FASTEST sail boat ..... \$1.50

5c Send 5c for an illustrated booklet containing all models shown above and other latest model airplanes, and model airplane supplies. Don't fail to send for it.

### BLUE PRINTS

FULL SIZE AND SCALE  
FOR FLYING MODELS  
24" WINGSPAN

|                           |             |
|---------------------------|-------------|
| Curtis Hawk B.G.          | .....\$0.40 |
| Curtis Hawk P.3.A.        | ..... .40   |
| Sea Hawk P.7.C.1.         | ..... .40   |
| S.E.5.A. Scout (1917)     | ..... .40   |
| Vought Corsair            | ..... .40   |
| Travel Air "Mystery Ship" | ..... .40   |
| Lockheed "Sirius"         | ..... .25   |
| German B.F.W.             | ..... .25   |

#### FOR ALL WOOD DORNIER "DO-X"

|   |             |
|---|-------------|
| 7 full size sheets of blue prints to build above "DO-X" | .....\$1.50 |
| All wood model, exact scale                             | ..... .25   |
| Sikorsky (10 place)                                     | ..... .40   |
| Ford Tri-Motor  | ..... .40   |
| Stinson Detroiter                                       | ..... .40   |

#### SPECIAL SCALE PRINTS

(All 10" to 15" Wingspan).....

|   |             |
|---|-------------|
| Two plans on one blue print.                    |             |
| Curtiss Hawk P.3.A. and Travel Air Mystery Ship | .....\$0.25 |
| Curtiss Hawk P.6. and Boeing Pursuit            | ..... .25   |
| Boeing Model 80.A. and Curtis Contor.           | ..... .25   |
| Sikorsky S.38. and Boeing Model 201.            | ..... .25   |
| Fokker D.7. and S.E.5.A.                        | ..... .25   |
| Supermarine Napier and Mercury Racer            | ..... .25   |
| Wallace Touro Plane and Inland Sport Plane      | ..... .25   |
| Keystone Bomber and Hall Aluminum Patrol        | ..... .25   |

#### EXTRA SPECIAL SCALE PRINTS

Three plans on one blue print.

|  |             |
|--|-------------|
| "Aveo Trainer," Bristol "Bulldog" Fighter and Cerva Autogiro | .....\$0.25 |
|--|-------------|

#### FLYING MODELS

18" Wingspan

|              |             |
|--------------|-------------|
| Stinson, Jr. | .....\$0.25 |
| Fokker D-7   | ..... .25   |
| S.E.5.A.     | ..... .25   |

### DORNIER DO-X

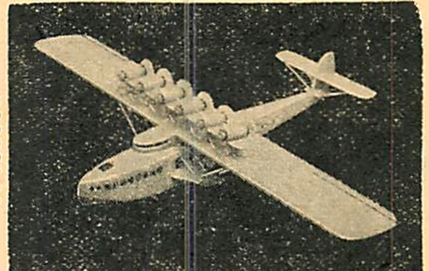

Kit set to build the above DO-X contains all the wood parts cut to size and shape, but not finished, also 7 sheets of layout blue prints, Wingspan 18". An ideal model for display. If you are not an experienced model builder or can not read a blue print don't buy this kit. Photograph of actual model constructed by purchaser (unsolicited). Price for kit \$3.25 post-paid.

### GAMECOCK R.O.G.

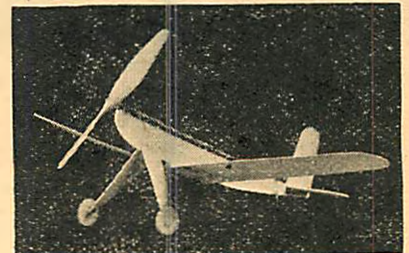

ALL BALSA

Kit set contains everything cut out to size, all balsa. Easy to construct and fly. Has repeatedly gained altitudes of over 100 feet, with dead stick landings. PRICE FOR KIT, \$0.75, postpaid.

## Hawk Model Aeroplanes

4944 IRVING PARK BLVD.

DEPT. K3

CHICAGO, ILLINOIS, U. S. A.



# Get a Glidex Without Cost

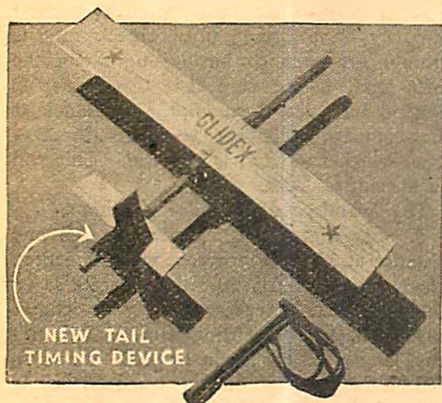

## GLIDES 4 CITY BLOCKS!

What a glider! Goes over 100 feet high and sails gracefully for 4 city blocks. The new tail timing device does the trick. Controls it like a real pilot. Durable—shock proof wing mount. Cambered Balsa wing and rudder for least air resistance. Complete with slings and two lengths of rubber for only 35 cents. Send coin—no stamps.

## Get Your Glidex FREE

Send six Glidex models to your friends and get yours free for yourself. That's easy. Send \$2.10 for six and we will include one extra for you. Or send 35c in coin for one.

## BADGER TOY CO.

Dept. M4, 3045 Walnut Street  
Milwaukee, Wisconsin

# Look Boys!

Home-made model aeroplanes made to order and guaranteed to fly or money back. Each model will be tried before you get it, ready to fly. Write to BROWNIE & EDDIE MODEL AEROPLANE SHOP at 66 Haven St., Buffalo, N. Y., for details. Model aeroplanes made any size or make. We also make any parts of aeroplanes, wings, fusilages, pontoons, tailpieces, etc. Get in touch with us and get some real prize winning planes. You won't regret it.

## AVIATION FREE Information

Send us your name and address for full information regarding the Aviation and Airplane business. Find out about the many great opportunities now open and how we prepare you at home, during spare time, to qualify. Our new book "Opportunities in the Airplane Industry" also sent free if you answer at once.

**AMERICAN SCHOOL OF AVIATION**  
Dept. 3154 3601 Michigan Ave., CHICAGO



## A Primary Glider

2 in. Airwheel—33 in. Wingspread

A glider that will thrill even the most experienced model builder. Adjustable controls, demountable wings, rudder and elevator. Gliding angle 13 to 1.

Experience the thrills of car towing, catapulting, loops and long flat glides.

- 2 in. Airwheel Clark Y wing sections, semi-constructed kit, easy to build .....\$1.50
- Improved new model Deluxe Golden Arrow..... 4.95
- Golden Arrow plans and instructions..... .60
- 14 in. Racing Pontoons, weight 1/3 oz.....1.25
- 36 in. Bowlius Soarer, semi-constructed kit..... .75
- 24 in. Bowlius Soarer, semi-constructed kit..... .50
- Box assorted prop. blocks, wire, rubber, bamboo... .50
- Complete 36 in. tapered wing with plans..... .50
- Catalog of new advanced models and kits..... .05

All the above are postpaid in U.S.A.  
**OLIVER P. DUNSTAN**

53 VINEWOOD AVE. PONTIAC, MICH.

# "Tale Spinning" With a Pioneer

(Continued from page 35)

fell for what seemed months to the three men. When a day finally came clear, and windless, their pilot was nowhere to be found. Frantically, the inventors searched for a substitute, and found one.

Hesitatingly they decided to entrust their plane to the new man and watched the result of their months of labor roll away from them across the flying field. Suddenly they saw the ship jerk into the air, climb steeply for a second or two, then stall, and crash tail first into the ground. The pilot, who was not a pilot, jumped from the wreck. Mr. Sturiali rushed toward the tangled mass. There was a roaring explosion, and the plane turned into a huge bonfire.

From that day on all Mr. Sturiali's efforts in aviation have gone into perfecting flying models and encouraging the ambition of American boys for aeronautics. With each year his skill and inventive ability seem to grow.

Model builders of a year or two ago will remember one of his inventions in the field of miniature flying ships. That model, the famous monoplane, "Flying Glory," used many new principles in the science of model construction. In particular, its triangular fuselage created a great deal of discussion and comment. Many regarded the unusual shape of the plane's body as a mere novelty, but experts saw in it a real advance in airship design.

One of the men who realized the great value of Mr. Sturiali's improvement was John Carisi. Not long ago, Mr. Sturiali received a letter from his old friend, saying that a two seater sport plane with the same triangular fuselage soon would be placed on the market. So Mr. Sturiali is, perhaps, the first model builder to reverse the usual process and have his model copied in a real plane.

Mr. Sturiali is now president of the Crescent Model Aircraft Co., in Brooklyn, N. Y. In the spring and summer months he may often be seen surrounded by large crowds, demonstrating his flying models in the various parks of the city. This fifty year old model designer and flyer will have absolutely nothing to do with a model that does not fly. Mr. Sturiali also expresses a strong dislike for "stick" models, for the reason that they have only a small educational value.

Although designing and selling model airplanes is now Mr. Sturiali's business, his enthusiasm for the hobby of flying and building miniature planes is as intense as ever.

"I am anxious," this pioneer once said, in answer to a question, "to see every boy in the United States interested in aviation. There is no more thrilling, educational and worthwhile hobby than building model airplanes."

Mr. Sturiali, a man of action, is characteristically doing his best to bring about this wish, in Brooklyn at least. The Crescent Model Club, membership free, meets every Thursday afternoon in the quarters supplied and fitted up by Mr. Sturiali. There any boy or man who wishes to come, may have the advice and encouragement of this great model expert.

# AIRSEAL Balsa

Model Builders attain the greatest success by using The Best Grade of Material. Air Seal Balsa is known as the highest grade of Balsa by the Model Airplane Builders. The Winners of National Contests are using Air Seal Balsa—Air Seal Balsa is sold in all sections of the country. If you do not use Air Seal Balsa try a sample order, we have a few standard sizes for immediate shipment.

Write for Free Booklet on Model Construction

Prices Including Postage on Sample Sizes

|                                |                |
|--------------------------------|----------------|
| 2" thick, 6" wide, 36" long    | at \$1.15 each |
| 3" thick, 5" wide, 40" long    | at 1.15 each   |
| 1/8" thick, 6" wide, 36" long  | at .55 each    |
| 1/16" thick, 6" wide, 36" long | at .50 each    |
| 1" thick, 4" wide, 36" long    | at .50 each    |
| 3" thick, 3" wide, 36" long    | at .85 each    |

Prices quoted on quantities of various Grades on request.

## THE FLEISCHMANN TRANSPORTATION CO.

Balsa Wood Division  
595 MADISON AVENUE  
NEW YORK, N. Y.

327 So. La Salle St., Chicago, Illinois. 245 - 11th St., San Francisco, Cal.

### METAL FITTINGS

|                   |          |
|-------------------|----------|
| 24 Asst. Washers  | ONLY 10c |
| 2 Thrust Bearings |          |

The finest made. Used by Champion flyers. Prepaid

|  |          |
|--|----------|
| 2 coils Music Wire (5 ft. ea.) choice of .010, .014, .018, .026 or .030. | ONLY 25c |
| 2 oz. tube SCIENTIFIC model airplane cement. Transparent.                | Prepaid  |

SCIENTIFIC TOYS  
LAKEWOOD, R. I., U. S. A.

4 Cylinder Air Motor Ready to Run \$7.50  
4-6-8 Cylinder Compressed air motors, also tanks seamless, 6-foot Lockheed-Sirus Motor model, New Curtis Hawks 24" hollow balsa fuselage and 28" Lockheed Sirius, rubber driven. Catalogue 10 cents.

**MINIATURE AIRCRAFT CORP.**  
83 Low Terrace New Brighton, N. Y.

## Look Fellows—Something New

12 1/2" FLYING SCALE MODEL of the famous Curtis Army Hawk and Navy Command Helldiver. ABSOLUTELY TRUE SCALE. No bamboo used. All balsa construction. Weight 1/2 oz. Will fly at an average height of 20 feet at a speed of 25 m. p.h. and banks like the real plane. BE THE FIRST!—BE DIFFERENT! Send 25c. for complete LIFE size blueprint.

Standard Model Airplane & Supply Co.  
3227 White Plains Road, New York City

## Coste's Sesquiplane

We have a flying model of this wonderful plane that is a dandy 25" silk covered wing, pants covered wheels, finished propeller, indestructible landing gear and our special hollow balsa fuselage that will outlast a dozen paper covered models.

Complete kit, all parts made to correct size, postpaid, \$4.00. Hollow Balsa fuselages for the following models, average weight less than 1/2 oz.

|                      |        |
|----------------------|--------|
| Curtis Hawk, 14"     | \$1.65 |
| Curtis Sea-Hawk, 14" | 1.65   |
| Boeing Pursuit, 15"  | 1.75   |
| Lockheed Sirius, 15" | 1.75   |
| Lockheed Vega, 15"   | 1.75   |

We can make up any special fuselage from your own plans at 15c per inch up to 18" long.

Pants covered wheels 1 1/2" 60c per pair.  
8 inch spinner propeller 65c, 10" 75c.  
Hill-Top transparent cement in tubes, 15c and 25c. Send 10c for mounted tail-skid wheel and catalog. Stamps accepted under \$1.00, all prices postpaid.

HILL-TOP MODEL AIRCRAFT CO.  
2553 Ring Place Cincinnati, O.



## Gliding and Soaring

(Continued from page 18)

between the magnetic, or true, pole of the earth, and the geographic pole which has been arbitrarily located by scientists. Charts may be obtained explaining how to correct for variation in different parts of the world.

**Suitable Clothing for Long Flights.** In making preparations for a long flight, you should have the proper clothing. Although it may be warm and sunny when you take off, weather conditions often change with surprising celerity. Cabin gliders (i.e., gliders with enclosed cockpits) have been built but they are very uncommon. Ordinarily, the pilot is exposed to the air as the wings on most gliders offer only slight protection from possible rain.

Waterproof coveralls, of light weight for summer, and of warmer material for winter wear, are an excellent form of clothing. In cold weather, you should have lined boots or overshoes; mittens are the best covering for the hands, and they are not too great a handicap in maneuvering the ship.

A helmet and goggles, such as are usually worn by motored plane pilots, are sometimes used by soarer pilots when they start out on long flights. If you are accustomed, however, to recognizing wind currents by blasts of air against your face, you may find such head covering an impediment.

**Other Provisions for Long Flights.** You should have all possible accessories for your comfort, as well as the proper clothing. The constant alertness, watching for air currents, and the strain of maneuvering the ship for hours at a time, are very wearisome. Some pilots have been obliged to land, while the soaring conditions were still good, on account of fatigue. Therefore, cockpits should be made as comfortable as possible (although they may be conducive to sleep unless they force the pilot to sit fairly erect).

Moreover, you should take some food. Dinort, a German flyer, says that the most satisfying lunch, and one which does not weigh too much, consists of two sandwiches, two cakes of chocolate, and a bottle of lemonade. In cloud flying, flying over mountainous terrain, or in airplane towing, a parachute is advisable as an additional safety factor.

**Preliminary Study of Map.** Before setting out on a long flight, you should become thoroughly acquainted with a map of the surrounding region. The map should be as large and as detailed as possible without being unwieldy. You indicate on it all places where upward currents are known to exist. With this information you can plan beforehand what course to follow and what means may be used, under various weather conditions, to move from one upward air region to the next. It is advisable to know what sections of the terrain are impossible as landing places in order that you may avoid them.

Familiarity with the map of the entire surrounding region, as well as with those routes which you hope to be able to follow, is advisable. It is quite possible that you may discover useful air currents in unexpected places, or that you may be forced out of your intended course.

You should keep this map with you during your flight. By comparing it with land-

marks on the terrain beneath, you will be constantly informed of your whereabouts.

**Preliminary Study of Weather Conditions.** When everything is in readiness, you may be obliged to wait until weather conditions are propitious for a long flight. What these weather conditions must be depends a good deal on your knowledge of the various methods of soaring and your ability in handling the glider. However, in general, there must be a good wind and no danger of precipitation in the form of snow or ice which might cling to the ship. Sunshine usually produces an abundance of thermal upward currents which may be of use. On the other hand, storms supply plenteous and sometimes violent energy which some pilots have been able to transform, without harm to themselves or to their ships, into soaring energy. However, unless you are very experienced and have a strongly built ship, you will do well not to brave such furious conditions of the elements.

**The Ground Force.** One way to aid your flight is to maintain a force of assistants on the ground. There is a great number of duties which may be delegated to it.

The members of the ground force may be stationed at intervals along the intended course of the ship. A good part of the time they may be able to call to the pilot from the ground; but, if the soarer is flying high, they will be obliged to use some method of signalling. Probably the commonest method of signalling is by semaphore. (See illustration.) Light radio sets have been used in America.

In night gliding, a ground force is particularly necessary.

**How to Make a Duration Flight.** Once you have started on a flight which you hope to prolong for hours, you will be able to maneuver the ship in the same way as during short hops, because you customarily remain in the air approximately above the same place. Nevertheless, you will probably use more than ordinary precision in order to obviate the possibility of mishap.

Duration flights are usually made by making figure eights along a ridge. This is a comparatively simple process, since it is so repetitious. However, because of the very repetition, you must remain constantly on your guard. By heading in one direction a little too long, you may pass the zone where the upward currents are most powerful, thus losing a good deal of altitude. Moreover, the wind is apt to change quite suddenly, and you must watch both its direction and velocity.

**How to Make a Long Distance Flight.** Long distance flights are more difficult than duration flights because the conditions are constantly varying. This calls for great alertness. The more familiar you are with the air, and the more kinds of wind currents you are able to make use of, the more successful you will be at long distance gliding. Long distance flights ordinarily are made by going as far as possible without any loss of altitude, and then, if feasible, by returning over the same ground.

**Night Gliding.** Comparatively little attempt has been made to glide at night. This is probably due more to the compara-

# U.S. ARMY HAWK



\$ **1.00**

POSTAGE  
PREPAID

FOR COMPLETE KIT



**COMPLETE KIT**—Includes Full-size plans; Detailed Building Instructions; Ambroid Cement; Banana Oil; Featherweight Celluloid Wheels; Japanese Hakone Covering; Plenty of Grade "A" Balsa Wood and Supplies—AND RED, WHITE AND BLUE MILITARY INSIGNIAS (Stars, Stripes, U. S. Army, etc.) Also Pictures of the Model. Everything snugly packed in box and mailed in very strong shipping carton. All for the price of only—

## One Dollar!!

ASK YOUR DEALER OR DEPARTMENT STORE FOR THIS KIT—OR Send your remittance (cash—check—or Money Order) to:—



(No postage stamps or foreign coin accepted.)

### A. A. C. MODEL AIRCRAFTERS

4719 Third Ave., New York City



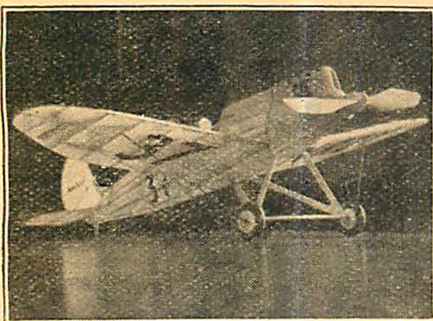

**SPEED DEMON!**

This speedy, long-flying racing model is a clean-cut replica of the famous Howard Low-Wing Single Seater Racer. Model is approximately one-eleventh the size of the actual machine. Flights of close to 90 seconds have been made with it. Kit is very complete and new method makes construction simple. All materials to dimension and actual size blueprint and instructions, postpaid.. **\$1.50**

**22.5 Min. Twin-Pusher**

An entirely revolutionary idea has made this model capable of flights which has made it world-famous. A soaring model! Complete kit with three **\$2.95** large blueprints sent postpaid .....

**Learn to Design Original Models**

The Model Flyer's Guide tells you how the other fellow gets such marvelous flights out of models looking no different than yours. The "low down" on this model business made simple for **35c** you—put out at a special price of only..

**Send 5c Coin for Catalog No. MM**

Ask for our new catalog No. MM, 5c coin. Shows world famous models and highest grade materials at way low down prices.

**Pioneer Model Airplane Supply Co.**  
CHAMPAIGN, ILLINOIS

**Aerocraft Models**

**12" MYSTERY SHIP—50c.**

This is a beautiful red and black tissue covered scale model with removable wings and adjustable diedral. (24" model to order—\$1.90.)

The Kit contains dimensioned scale drawings, instructions, semi-finished prop., stamped ribs and formers, and all necessary material.

**12" FLYING STICK—25c.**

This plane is very simple to construct and is guaranteed to fly.

**"AEROCRAFT"**

Galva Illinois

**We Will Print**

**50** Beautiful Cards with your name and address, for **50c**

Card case given free!

**SHOLMAN PRINTING COMPANY**

108-45 Corona Avenue Corona, N. Y.

**3-CYL. RADIAL Air Motors and Tanks Won All Air Model Prizes Chicago National Air Races August, 1930**

**THE HOOSIER WHIRLWIND COMPRESSED AIR MOTOR**

WT ONLY 3/8-OZ  
3-IN. DIAMETER  
3/8-IN. BORE  
3/8-IN. STROKE  
STRONG AND POWERFUL

Counter balanced steel crankshaft. Unique. Fits 4 1/2" to 8 ft. models. Finished parts, easy to assemble, \$1.95 postpaid. Completely assembled and tested \$1.75 postpaid.

Compressed Air Tank—Greatest scintill high pressure, 1" diameter, 30" long, 57 postpaid; 24" long, 16.10 postpaid.

Motor and 24-in. Tank Combination—Wt. complete only 8 1/4 oz! Send this ad. \$10.10 postpaid.

Complete Kit for 5 ft. Compressed Air Model with blueprint less tank and motor \$4.00 postpaid. Have an air model for your next National Model Airplane contest. Order today! Be sure and enclose only money orders or drafts.

Rubber 1/32" x 1/8" Ext.—full fresh skins special price only 72c. postpaid (1/32" x 1/16" 70c. postpaid).

Best Rubber Lubricant Known—Doubles winds. Used on all latest record models. Big 2 oz. can only 30c. postpaid.

Send 10c. at Once for a New Illustrated List Just Off the Press showing all the latest and best materials as used by recent National contest winners of trips to Europe, etc., with surprising low prices on the best materials. Schools, clubs, dealers write for terms.

"Model Airplane Experts of Today are the Aviation Experts of Tomorrow."

**PERU MODEL AIRPLANE SHOP**  
Dept. J, Peru, Indiana

tive calmness of the night air than to the darkness.

Some notable night flights have been made, however, such as those made by Bowlus, and by a German named Dinort, who made a duration flight of fourteen hours and forty-five minutes. The row of peaks, above which Dinort was gliding, was well lighted by a ground force. Twin lights were placed at either extremity of the range and single lights marked the intermediate summits.

The guards who were stationed to watch the lights and to make meteorological reports through megaphones to Dinort, worked in shifts of three hours each. They found that oil lanterns gave a more diffused, and therefore a more satisfactory, light than flashlights. However, the lamps would not give a constant light because of the high wind, so that flashlights had to be used to supplement them whenever the ship approached the ground. The guards experimented with large mirrors to reflect the lights, but this was unsuccessful because the swirling sand soon destroyed the mirrors.

Dinort reported that the darkness made him lose the feel of the controls; he had difficulty in maintaining his course since he had no instruments. For this reason, night

glides should not be made without instruments. The visibility is especially poor at twilight and at dawn. At those times, also, the wind is apt to die down.

Better lighting devices than those used by Dinort's guards are available in most places. A row of automobile headlights will illuminate a wide expanse of fairly level ground. Beacons, like those used in airports, shoot streaks of bright light through the air. Gliders might, without great increase of weight, be equipped with small wing-tip lights. In landing, the pilot might drop a small flare, supported by a parachute, to light the ground.

**Conclusion.** Duration and long distance flights are an extremely important phase of gliding. Most people have a strong competitive spirit and are incited by the possibility of making new records. (In America no records are official unless made in the presence of judges approved by the National Aeronautical Association.) Moreover, since a pilot who is attempting to make a long flight will resort to almost any means in order to remain in the air, he is apt to discover new methods of soaring. A great many of the advances in soaring have been made during record flights.

**All Aboard, Model Trainmen!**

(Continued from page 31)

that it is a model instead of a real train. Look at this picture of the signal tower and notice how real the locomotives look underneath it, as they wait for a 'go ahead, all clear' signal. A photograph is the real test of a model.

"I believe in model-trains," Alexander goes on seriously. "I hope to see more and more boys and men get the bug in this country, just as they have in England and many other countries on a large scale today. Suppose that the hobby is a little more expensive than some others?"

"A lot of boys have answered that prob-

cept by Alexander himself) and some in planning the roadbed, the bridges, tunnels, and scenic effects. When the system is in operation there will be plenty for everyone in the club to do in the problems of railroading, in giving train orders, making up trains, keeping schedule, and otherwise in acting out the part of every unit in the personnel of railroading. It's the grandest fun in the world!"

Well, boys, if we are to keep on schedule, as all model trainmen must, we'd better be climbing up into the cab. The "bolt-splitters" have our engine readied and trim-

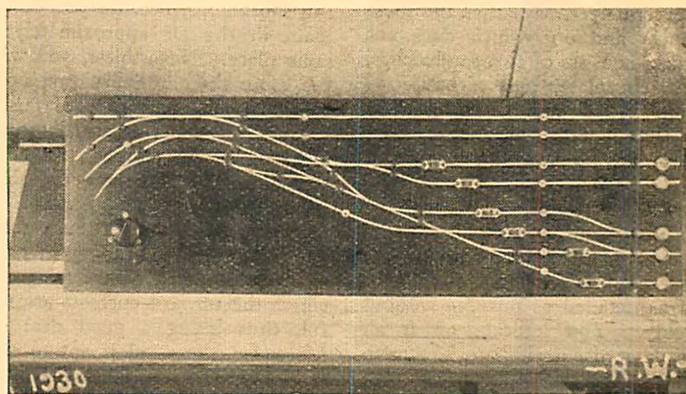

SIGNAL CONTROL BOARD

lem by forming a club in their own city, and thus by pooling their resources they can afford to buy the locomotives, which are, of course, the costliest part of the rolling stock. Model railroad operation is the sort of fun that increases as there are more to share it. Some of the model-fans can specialize in locomotives, some in rolling stock, some in switches, some in the safety control systems, some in electric wiring, some in signal engineering, which is a model field as yet practically untouched (ex-

med, with her boilers full of steam and her tender full of coal. There is a roar in the fire-box, and the smell of steam and wet coal is in our nostrils. Give two yanks on the whistlecord, you trainmen, and shove on the throttle. There's our "all-clear" board shining through the night, yellow and green.

Abo-o-o-a-a-ard! Wave your gloves to Edwin P. Alexander, who has given us a great afternoon. Come on, you "hoggers," here's the crossing. One blast of the whistle . . . and you thunder through onto the main line!



# Mystery of the Silver Dart

(Continued from page 26)

was revelling in a hot bath and, later, the comfortable feel of clean clothes. Within an hour he was on his way to Kingston where, during his absence, the news of his and Ruddy's arrival had been made known in "extra" editions of the local paper.

Once again crowds were lining the waterfront when the Loening alighted. The amphibian had been sighted as it crossed the Palisades and from that time until Ian stepped ashore, there had been a continuous round of cheering.

There is no need to go into details of the reception or banquet. These things are the same the world over. Speech followed speech, and congratulations poured in. Few, however, knew what really had happened. The majority, of course, were puzzled. They sensed that something was in the wind but could not fathom it.

During the banquet Ian was handed a telegram (it was one of hundreds, of course) but it made him happier than all the others put together. There were only five words, but they made his heart glow and brought a lump to his throat. The words were:

"GOOD LAD—MOTHER—GENII—BEECHAM"

After dinner, Ian, the captain of the *Saratoga*, the American Consul and a few other officials were sitting on the "Crow's Nest"—a verandah-piazza sort of place which jutted out from the officer's mess into the mess gardens—sipping coffee. Ruddy was in the billiard room taking a drubbing from Lieutenant L. E. Ottley, the British West India Regiment, who was camp champion. Ian was talking.

"The human body must be a funny institution," he was saying. "Here am I. During the past thirty-six hours or so I suppose I've been through as nerve-racking an experience as one could possibly imagine. Yet it all seems like a dream to me and I'm sure my companion must feel the same way. In fact, I'm waiting for someone to pinch me and wake me up. . . ."

The captain intervened: "All right, my lad, we'll do that for you sometime next week. You and Arnold are returning to the *Saratoga* tonight—the Fokker is or should be on board by now—and we're returning post haste to Washington."

The captain knew what he was talking about. Two hours later Ian and Ruddy were snuggling in comfortable beds aboard the *Saratoga* and soon were asleep. The sun rose twice in the east before it interested them in the slightest. Even then, they merely opened their eyes because they were hungry.

\* \* \*

The end is nearing—but stay with our heroes a bit longer.

For three days they sunned themselves on the quarter-deck of the *Saratoga* as that monster aircraft carrier plowed its way through the blue Caribbean and into the Atlantic to Washington, flanked on each side by a destroyer. The captain proved a friend, indeed. He kept them posted on all news received by wireless.

## THIRD ANNIVERSARY SALE

In three short years COUNTRY CLUB has flown to the front rank. There's a reason for our remarkable growth and if you haven't yet discovered it, compare these DELIVERED prices. There are no packing or postage charges to add if you live in the U. S. A. We deliver the goods to your hangar and the quality is guaranteed.

### CELLULOID SPECIALTIES

Nine cylinder double impression dummy motors drilled for 1/8" shaft 35c. Single impression 25c. 3" black celluloid cowlings 25c. Black celluloid pants to fit our 1 7/8" or 1 3/4" wheels 17c each. Light weight sheet celluloid 50 sq. in. 8c.

### CELLULOID WHEELS

We stock a complete line of black celluloid wheels in all sizes. The 1 3/8" and the 1 7/8" wheels are furnished with a small eyelet bearing. Check these prices—3/4" 4c each—1" 4c each—1 3/8" 6c each—1 7/8" 9c each—3" 15c each.

### ALUMINUM WHEELS

Aluminum wheels with balloon tires. 1-1/2" 10c each. 1-3/4" 11c each. 2" 12c each.

### COVERING MATERIALS

Large sheets of 21"x31" Japanese Mino silk or White Hakone 4c each or 40c per dozen. Smaller sheets of Superfine or Red Hakone furnished for the same price. 20"x30" sheets of Wood Venger paper 15c each. Imported white china silk \$1.50 per yard.

### AMBIROID CEMENT

Genuine Ambroid either colored or colorless. One oz. 13c, two oz. 20c, four oz. 38c.

### BAMBOO

Straight grained selected bamboo averaging 1/16"x1/4" furnished in either 12" or 15" lengths for 1c per strip. 12" lengths 8c per dozen, 15" lengths 9c per dozen. Shredded bamboo averaging 1/32"x1/16"x1/2" 7c per doz.

### CLEAR AND COLORED DOPES

Clear nitrate dope—our special mix. One oz. 8c, two oz. 14c, four oz. 26c. Colored pigmented dopes any color you wish, one oz. 12c, two oz. 20c, four oz. 36c. Reduced prices on two and four oz. cans do not apply on one oz. assorted color orders.

### MUSIC WIRE

All of our music wire has been tinned to prevent rusting. Six sizes to select from at these bargain prices. .016, .022, .026—three feet per cent; .033, .039, .045—two feet per cent.

Our new 1931 catalog is just completed. It contains hundreds of bargains similar to the above, our complete price list of Balsa Wood, and a brief description of the Flying Fool. Send five one cent stamps for it, or better still send us a 50c trial order and the catalog will be included free.

## COUNTRY CLUB AERO SUPPLY CO.

MAIL ORDER DEPT. 5821 HOLMES STREET

Kansas City Retail Shops, 1103 East 59th Street and 221 West 47th Street.

"Where your dollar has more cents."

KANSAS CITY, MO.

# AERONAUTICAL ENGINEERING

## DEGREE IN 2 YEARS



Write for catalog

Save time and money by taking the Tri-State College course in Aeronautical Engineering, 108 weeks. Bachelor of Science Degree. Graduates in Mechanical Engineering can complete course in two terms (24 weeks). Thorough training in all fundamental engineering subjects. Non-essentials eliminated. Courses designed to save student time and money. Flying school facilities available at nearby airports. Enter September, January, March and June. College now in 47th year. Courses are offered in Civil, Electrical, Mechanical and Chemical Engineering. Also Business Administration and Accounting. Living costs and tuition low. Those who lack high school may make up work. Graduates successful. 841 College Ave., Angola, Ind.

# TRI-STATE COLLEGE

## Look—Fellows—Look!

### Model Aviator Featherweight Motor

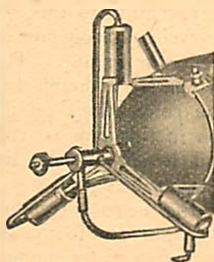

New rock bottom prices—All parts bent, formed, drilled and timed. Knock-down kit, only. 3 large plans scale models, 7 samples and airplane catalog.. 25c  
1 plan, "Vega" and catalog .....10c

### MODEL AVIATOR PRODUCTS

9-W-Illinois Street, Chicago

## Model Aeroplanes

Realistic and instructive all Wood Construction Kits—easy to assemble following our full size blue prints and directions. Each Kit contains all necessary parts cut to size—ready to be finished and assembled for the following models:

CURTISS HAWK 15"  
SIKORSKY AMPHIBIAN 15"  
STINSON JUNIOR 15"  
CURTISS CONDOR 20"

PRICE \$2.50 EACH—PREPAID

Prices for other models and for completely finished planes—making beautiful ornaments for the home or novelty gifts—upon request.

Address all orders to:

AERO-CRAFT, DEPARTMENT B  
3311 Chrysler Bldg., New York, N. Y.



GET THESE FREE  
IF YOU JOIN THE

Na-bor-hood Aviators Club  
Get Your Membership Card and Pin  
— NOW —

R. O. G. 35c

Grease Monkey Pin, Membership Card, Ready Made Propeller, Ready Made Wire Fittings, Cement, Paper, lots of Extra Material.

Bellanca Seaplane or Navy Vought Corsair } \$1.75 ea.

Full Size Plans—Colors, Everything Necessary to make Pilots Pin } FREE with Membership Card } either model

MODEL AIRPLANE SHOP, 657 N. Bouvier St., Philadelphia, Pa.

RUSH—Included find \$..... (no stamps), for which send me item as checked.  R.O.G. Kit, 35c Pin and Membership FREE;  Bellanca Seaplane \$1.75, Pilot Pin and Membership FREE;  Navy Vought Corsair \$1.75, Pilot Pin and Membership FREE. Dept.—M.A.N.





# LOWEST PRICES

## Finest Quality

### New Policy

The SOUTHERN MODEL AIRPLANE SUPPLY CO. makes the following astounding announcement: "We offer our usual fine high grade balsa wood in a new length, 36", at rock bottom prices. This new length eliminates waste both at the factory and with the modeler, and is sufficiently long to make any standard model."  
 In order to get the benefit of these prices we require an order to be not less than 50c. 10c packing charge must be included with all orders except those for kits. Buy now for your new season.  
 Twelve hour service on all orders. Full stock on hand.

| BALSA SPARS.                               |            |
|--|------------|
| Size                                       | Price each |
| 1/16 x 1/16 x 36"                          | 1c         |
| 1/16 x 1/8 x 36"                           | 1c         |
| 1/8 x 1/8 x 36"                            | 1 1/2c     |
| 1/8 x 3/16 x 36"                           | 2c         |
| 1/8 x 1/4 x 36"                            | 2c         |
| 3/16 x 1/4 x 36"                           | 2c         |
| 1/4 x 1/4 x 36"                            | 2c         |
| Special Twin Pusher Motor Sticks 40" long. | 2 for 5c.  |

| SHEET BALSA    |            |
|----------------|------------|
| Size           | Price each |
| 1/32 x 2 x 36" | 6c         |
| 1/20 x 2 x 36" | 7c         |
| 1/16 x 2 x 36" | 7c         |
| 1/8 x 2 x 36"  | 8c         |

| PLANK BALSA |            |
|-------------|------------|
| Size        | Price each |
| 1 x 3 x 36" | 10c        |
| 1 x 6 x 36" | 70c        |
| 2 x 3 x 36" | 1.00       |
| 2 x 6 x 36" | 1.25       |

Full stock of new A.M.E.L.A. Kits: Baby R.O.G. (3 in 1) 50c; Soaring Glider 25c; Indoor Fuselage 75c; World's Record Tractor \$1.25.

**SOUTHERN MODEL AIRPLANE SUPPLY CO.**  
 P. O. BOX 140  
 Atlanta, Georgia

## WANTED

Model Air Plane Builders

We offer to Boys and Men everywhere who like to build model airplanes an exceptional opportunity to cash in on their experience. For particulars write

**National Model Aircraft & Supply Co.**  
 29 North Ave., Dept. 11, New Rochelle, N. Y.

## BUILD THE BALSA WOOD HULL 25" MODEL YACHT

|                               |        |
|-------------------------------|--------|
| Instruction Pamphlet          | \$ .25 |
| Balsa Wood Block 4x8x25" long | 2.25   |
| Semi Shaped                   | 2.50   |
| With Mahogany Deck Plate      | 3.25   |
| Complete Kit                  | 12.00  |
| Model Yacht Ready to Sail     | 18.00  |

Remit by Check, Express or U. S. Money Order.  
 Model Boats of Balsa and Hardwood.  
 Prices of other Supplies and Models on request.

**MODEL CRAFT STUDIO**  
 Seaford, N. Y.

## CUT RATE BALSA PRICES

### QUALITY SELECTED

**Selected Sheet Balsa**

|                       |                        |
|-----------------------|------------------------|
| 6 sheets 1/32"x4"x21" | \$.40 or 8c each sheet |
| 6 sheets 1/20"x4"x21" | .45 or 9c each sheet   |
| 6 sheets 1/16"x4"x21" | .50 or 10c each sheet  |
| 6 sheets 1/8"x4"x21"  | .65 or 12c each sheet  |

**Supreme Quality Polished Balsa Strips**

|                           |                           |
|---------------------------|---------------------------|
| 50 strips 1/16"x1/16"x21" | \$.20 or 10 strips for 5c |
| 50 strips 1/16"x1/8"x21"  | .25 or 8 strips for 5c    |
| 50 strips 1/16"x3/16"x21" | .30 or 6 strips for 5c    |
| 50 strips 1/16"x1/4"x21"  | .35 or 6 strips for 5c    |
| 50 strips 1/8"x1/8"x21"   | .30 or 6 strips for 5c    |
| 50 strips 1/8"x3/16"x21"  | .35 or 6 strips for 5c    |
| 50 strips 1/8"x1/4"x21"   | .40 or 4 strips for 5c    |
| 50 strips 1/8"x5/16"x21"  | .45 or 4 strips for 5c    |
| 24 strips 3/16"x3/16"x21" | .20 or 5 strips for 5c    |
| 24 strips 3/16"x1/4"x21"  | .25 or 4 strips for 5c    |
| 24 strips 3/16"x5/16"x21" | .30 or 3 strips for 5c    |
| 24 strips 3/16"x3/8"x21"  | .35 or 3 strips for 5c    |
| 24 strips 1/4"x1/4"x21"   | .25 or 4 strips for 5c    |
| 24 strips 1/4"x3/8"x21"   | .35 or 3 strips for 5c    |
| 24 strips 1/4"x1/2"x21"   | .45 or 2 strips for 5c    |

Ten (10c) cents postage and packing charge must be included in all orders. Only postal money orders accepted. Send cash at your own risk. No orders under 50c accepted. Not responsible for loss in mail. Add 5c for insurance if desired. Your orders promptly filled.

**Long Beach Balsa Syndicate**  
 Dept. A, 548 W. 6th Street, Long Beach, Calif.

That officer was now walking towards them, holding in his hand a piece of paper. "Good morning, sir," said the two companions, Ian adding:

"I understand that three destroyers accompanied the *Saratoga* to Jamaica—?"

The captain smiled. "Funny you should ask that," he said. "Read this; it might interest you. It's from the other destroyer." Ian took the paper from him and Ruddy bent over to read it with him. On the paper was a message as follows:

"Regret to report prow of 241 badly damaged in collision with derelict stop no assistance needed heading for Pensacola."

Ian and Ruddy looked puzzled. "I'm sorry to know that," they said in unison.

The captain looked at them and laughed heartily. "Why, you poor innocent babes. See that word 'derelict'? That word means *Submarine W9*. See now? Our friend tried to get away. I left 241 purposely to watch for that. The American Government couldn't exactly steal a submarine belonging to a foreign power, but it certainly is no fault of ours if one of our destroyers comes in collision with—perhaps I should say 'rams'—that submarine in the dark. Is it?"

Ian and Ruddy joined in the laughter. They, too, saw through it all now. Of course, destroyer 241, and no one else for that matter, would report such a collision, or ramming, as being with anything else but a *derelict*.

There is little or nothing more to be said.

The *Saratoga* reached Washington safely. Admiral Beecham, true to his word, had released to the newspapers the news of Ian's feat. Such news, of course, had produced a furore all over the country. Ruddy, too, shared in the fame and glory that followed.

Ian's reinstatement in the Air Corps—the reason for his being asked to leave had been explained, of course—was followed by the notification that he had been promoted to Squadron-Leader of the first squadron of *Silver Darts* built for the U. S. Navy, with special privilege to carry as his personal insignia on his plane a shield bearing a grey submarine, its back broken in the middle, prow and stern out of the water, with a silver dart piercing it at the break.

Who can describe Ian's pride and emotion when, as leader of the first squadron of *Silver Darts*, he sat in the cockpit and looked back over the tail and saw his brood following him? They were flying in a tight "V" formation in a demonstration flight over Washington. Only a few feet separated each machine. In Number 2 machine to Ian's right rear sat Ruddy, who had been granted a commission in the Navy Air Service.

Ian's throat tightened and he gulped. Then, ashamed of his own emotion and though knowing full well that he could not be heard above the roar of the engines, he essayed a grin and shouted back to Ruddy:

"Hey, Mournful, can't I ever lose you?"

Ruddy waved back and for once in his life, really grinned.

THE END

## Airplane Engines

(Continued from page 6)

The most popular air-cooled engines of today are of the radial type with an odd number of cylinders, though any number may be used. Every other cylinder fires in consecutive order. In this way, two revolutions of the engine are required for all cylinders to fire.

The Caminez is an exception to this. It goes through all four cycles during one revolution of the propeller or engine. This is because the pistons operate a double lobed cam instead of the conventional crank. The inherent vibration in this type of construction is great and its production has been stopped for the time being.

We have seen that the air-cooled engine has the advantage of weight due to the absence of the radiator, cooling water, pumps, water jackets and the long crankshaft. Let us convert this light weight to practical terms. For the same payload it, first of all, gives a shorter take-off run, due to its greater rate of climb.

This means that the plane can operate out of fields that exclude the water-cooled engine ship. The landing run is also made shorter due to this lighter weight. The plane can come in safely for a landing at a much slower speed. Here again, the water-cooled ship is excluded.

The ceiling of the plane is greatly increased by the decrease in weight. This may mean that only the plane equipped with the air-cooled engine can operate over a parti-

cularly mountainous route. An aerial transport route exists between Callao and the headwaters of the Amazon. During this three hour trip an 18,000 foot altitude is reached in crossing the Andes. The Keystone Pronto equipped with the J-5 made this route possible. Incidentally, this route required three weeks to traverse before the air route was established.

The decrease in weight gives a lighter wing loading; that is, the number of pounds for each square foot of wing area. This quality gives greater maneuverability and in some degree, is a safety factor for military ships when pulling out of a dive. Or, if it is not desired to take advantage of the added maneuvering qualities of the plane with its lighter power plant, a greater payload bringing greater profit to the operator may be carried.

An incident will serve to illustrate the practical advantages of the lighter air-cooled engine. Pine Valley is a summer resort nestled in the inland mountains of Southern California. The valley is not large, but sufficiently so that it has a nine-hole golf course. Although lying at an altitude of about 4,500 feet, it is surrounded by mountains. A fair landing field is made by one of the fairways. The best approach, unfortunately, is generally down wind.

Due to the excessive number of crack-ups experienced by water-cooled planes in this field, they are barred from even attempting



to land. The heavy wing loading makes a fast approach necessary in the rare atmosphere of this altitude. The fast approach does not allow the plane to stop rolling quickly enough to stay on the field. Air-cooled jobs have no difficulty in getting in and out of the field.

When operating from high altitude fields, water-cooled types frequently find it necessary to wait until dusk or early morning to fly. The density of the air increases at night as the heat of the sun is dissipated. The denser air enables the heavier plane to obtain sufficient lift to fly. Furthermore, at high altitudes the cooling water is apt to boil away very quickly. Thus, a water-cooled engine may get too hot for satisfactory operation.

In an effort to increase visibility the air-cooled engine is assuming several forms. The plan is to reduce the large frontal area which also causes so much air resistance. Curtiss has met the problem by offering the stagger cylindered Challenger and the double banked hexagonal Chieftain engines. The Cirrus vertical air-cooled engine is a British attempt to give visibility. This problem is linked closely with that of speed. Unfortunately, the new N.A.C.A. cowling decreases visibility considerably, even though it does increase the plane speed. This does not matter on the wing engines of multi-engined ships.

Accessibility must be provided for in the design of an engine. The water-cooled engine is difficult of upkeep. Even if provisions have been made for removing separate cylinders, as in the Liberty, it is a great deal of trouble. Most of the cylinders of water-cooled engines are cast in blocks. This makes upkeep difficult and overhaul expensive.

On the other hand, the air-cooled engine can be opened up while still on the engine mount. Cylinders can be replaced and piston rings changed. The front plate can be removed and the engine thoroughly inspected.

A slight disadvantage of the air-cooled type is the possibility of uneven cooling of the cylinders. We have seen that heat control by means of shutters is now efficient enough to permit the long dives necessary for military work. However, take the case of slipping to a landing from an altitude, say, of 1,000 feet. The side of the cylinders on the underside of the ship will cool first. This uneven cooling is very apt to warp or distort the exhaust valves. This, of course, will necessitate their grinding more often. An approach to a field with power on will eliminate this difficulty.

Let us see what the future is apt to produce. We have seen that steam has been used and discarded. It weighs too much and possesses too great a fire hazard. Other vapors have been tried instead of steam. Mercury is one of these. Success, however, has only been slight. Electricity has been suggested with power being delivered by means of radio waves. We must wait to know the practicability of this scheme.

The proponents of the water-cooled engine have attempted to combat the air-cooled power plant by reducing the plumbing weight of the engine. In doing this they have produced a liquid commercially known as Prestone. This is a special compound that is very efficient in the transfer of heat. Its boiling temperature is 387 degrees Fahrenheit. In using this liquid only about

## NATIONAL MIDGET

### FLYING SCALE MODEL AIRPLANES

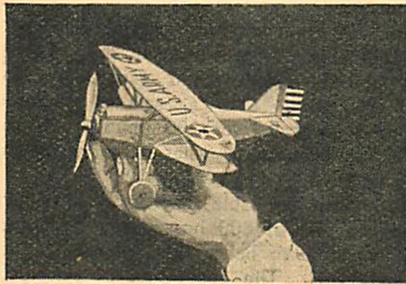

**MIDGET—ARMY—HAWK**  
Complete Construction Set, Postpaid \$1.10  
**MIDGET—HEATH—PARASOL**  
Complete Construction Set, Postpaid \$1.10  
**MIDGET—S-E-5.**  
Complete Construction Set, Postpaid \$1.10

**CATALOGUE**  
Describing Model Airplane Supplies of best quality at reasonable prices. Construction sets to build 2 ft. flying scale models, such as Hawks, Corsairs, Lockheed Sirius, Travel Air Mystery ship and many others. Send 5c and get one by return mail.

**NATIONAL MIDGET MODELS ARE SOMETHING NEW REASONABLE IN PRICE EASY TO BUILD GOOD FLYERS IN—AND OUTDOORS VERY LIGHT IN WEIGHT, THEREFORE SELDOM DAMAGED.**  
They Attract Attention Wherever Shown. Hundreds of Flights Are Possible.

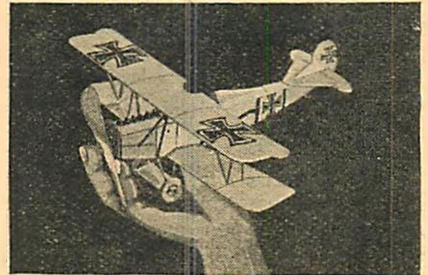

**MIDGET—FOKKER D-7**  
Complete Construction Set, Postpaid \$1.10

**ORDER TODAY**  
No C.O.D. accepted

**NATIONAL MODEL AIRCRAFT & SUPPLY CO.**  
29 North Ave.—New Rochelle, N. Y.  
DEPT. A-7.

#### AGENTS WANTED

We want one dealer or agent in every town to handle National Model Airplane Sets and supplies. Because of their proven quality, a National model dealer with sets and parts to supply immediate wants can make big money. Write for full details.

Name.....  
Address.....

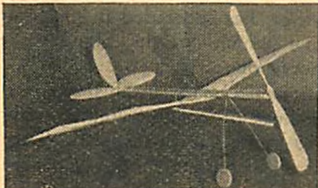

**BOYS:**  
Dandy new 3 foot "H. O.G." model. Designed from "Baby R.O.G." Easy to build, all balsa construction. Will fly indoors or outdoors.

Has a 15" prop. 30" motor stick (assembled) and 1 7/8" celluloid wheels. Kit includes 20 ft. rubber, tissue, wire and wood parts, and blueprint with instructions. \$2.00. Value for \$1.75 plus 10c postage. (Insurance 5c extra.)  
Gilders, all balsa, 20c ea. (6 for \$1.00) add 5c postage.  
Kit and Gilder ordered together \$2.00 postpaid.  
**MURRAY-MODEL SHOP**  
167 Hart Street, New Britain, Conn.



Better Models Than Has Been, models as low as \$1.50 each. To Cost Lead Soldiers, Indiana, Hunters, Wild and Farm Animals. Wonderful "True To Life Models." Easy and inexpensive to make. 1 furnish all necessary material—including enamel. Send 5c for illustrated Catalogue.

D. SCHIERCKE, GHENT, NEW YORK

## GIVEN

The **BABY PURSUIT PLANE**, a speedy little balloon buster of the latest design, will be given absolutely **FREE** to every purchaser of a **VERVILLE SCALE MODEL KIT** which sells for \$1.00 postpaid. This scale model kit contains the highest grade balsa wood, pure Para rubber, rust proof wire, Jap tissue, transparent glue, complete plans and directions. The flying qualities of this excellent model can not be beaten. Send \$1.00 and get these models at once. Don't wait, it may be too late. There's only a limited number left.

Here's Another Bargain—The **2 In 1 Kit** and the **Outdoor R.O.G. Tractor Kit**, Both for 95c.

The famous **2 In 1 Kit** and the excellent flying **Outdoor R.O.G. Tractor Kit** are now offered at a new combination price of 95c. The **2 In 1 Kit** builds the r.o.g. biplane and monoplane for indoor or outdoor flying, while the **Outdoor Tractor Kit** builds a new and better outdoor, rise off ground tractor.

Remember, the best materials build the best models and bring the best flights. All Ames-Harrell Kits are guaranteed to contain the highest grade materials, yet they are the lowest priced kits today. It pays to buy now. Send your money today. **AMES-HARRELL MODEL AERONAUTICAL COMPANY, 1319 Graydon Av., Norfolk, Va.**

#### MODEL AIRPLANE KIT GIVEN



SEAGULL BULLET

A midget in size but a giant in performance. An easily constructed twin-pusher that has made flights of over 3 min. Complete kit. With stamped ribs, all wire parts formed and full construction and flying directions. \$.85 p. p.

#### BOYS!!!

**BUILD A SEAGULL CHAMPION MODEL and enjoy your Easter Vacation.** Get the new Seagull Champion Helicopter Construction Kit. Complete Kit with all wire parts formed and full construction and flying directions, \$.35 p. p.

**Easter Specials**  
Balsa—1/8 x 2 x 36..... .07  
1/16 x 2 x 36..... .07  
1/32 x 2 x 36..... .07  
Colored or Colorless Ambroid, 1 oz..... .12  
2 oz..... .20c  
Banana Oil..... 2 oz. .13  
Superfine Tissue, .04 ea..... .7 for .25  
Music Wire .011, .020, .028, .034, 5 ft. .02  
Rubber 1/4 flat, .015 sq..... .5 ft. .02  
Aluminum Beauty Double Winder. \$1.20  
10c packing and postage charges must accompany all orders. No stamps accepted. Price list free. Dealers, clubs, schools, write for special price list.

**SEA GULL MODEL AERO CO.**

153 Beach 128th St.  
BELLE HARBOR, ROCKAWAY BEACH  
L. I., N. Y.

#### SEA GULL CLOUD BREAKER

A single pusher that circles gracefully and climbs to great heights. Flights of 2 min. and over easily obtained. Complete kit with stamped ribs, all wire parts formed and full construction and flying directions. \$.65 p. p.  
Special price, both kits....\$1.30





**AVAILABLE for the**  
**First Time**

After years of extensive experimenting and research work—Reliance Engineers, now present their first of a series of correctly designed Flying Model Aircraft in the form of . . .

**The FOKKER D-7**  
 (FLYING MODEL) 27" Wing Span



See this Plane featured in the Motion Picture, **HELL'S ANGELS.**

Scientifically and correctly designed for flying. A model that will respond to its movable controls, enabling you to break many present records. Learn some things about model aircraft you never know before. Easy to construct, due to Reliance simplified method of construction. Plus 60 per cent. more finished parts than usually furnished. All woodwork of Balsa construction, cut to size and length. Finished tall surfaces. Parts die cut where possible, such as ribs, etc., and many other features you will see when you get your kit, which will make you a Reliance booster in the future. **DO NOT** be misled by the low price. Modern production machinery alone allows such value for your money.

The FOKKER D-7 Construction Kit Complete with all materials, colored dopes. Full size **\$4.95**  
 Blue Prints with instructions . . .

DEALERS write at once for liberal proposition.  
**RELANCE MODEL AIRCRAFT CO.**  
 1304-18 N. Howard Street, Philadelphia, Pa.

**LOOK!**



A perfect model of the historic **WRIGHT BIPLANE.** Something very different and attractive. Makes perfect flights of 300 ft. or more. Can be used as a glider if desired. Will fly in strong or soft winds. Entire kit with all wood cut to exact size, all parts ready for assembling, no other work needed. Wing spread 21 in. Entire kit (knocked down) \$2.25 (assembled) \$3.75  
**Brentnall & Johnston** 3502 Cliff Rd. (cash)  
 Birmingham, Ala.

**HERE'S THE DOPE!!**

|                                  |                             |
|----------------------------------|-----------------------------|
| Clear Dope, 2 oz. . . . .12      | 1/8"x1 7/8"x36". . . . .25  |
| Clear Dope, 1 oz. . . . .20      | 10 strips. . . . .25        |
| Clear Dope, 1 pt. . . . .50      | 1/8"x1 3/4"x36". . . . .25  |
| Quick Dry Glue, 2 oz. . . .20    | 8 strips. . . . .25         |
| Wire, Nos. 5, 6, 2 ft. . . . .01 | Rubber, 1/20 sq. 3/32       |
| 1-32"x2"x36". 3 sheets . . .28   | flat, 1/8 flat, 2 ft. . .01 |
| 1-16"x2"x36". 3 sheets . . .35   |                             |

Add 10c to orders under \$1 for packing and shipping. Send 2c stamp for price list.

**VESPA MODEL AIRPLANE SUPPLY CO.**  
 3307 Virginia Dept. A Kansas City, Mo.

**ADVERTISERS IN  
 MODEL AIRPLANE NEWS  
 ARE  
 TRUSTWORTHY**

**MODEL AIRPLANE MATERIAL**

Big bundle of sample stock containing various sizes of balsa and other wood, flat and square rubber strands, music wire, Japanese tissue, reeds, round wood, bamboo and our low prices on model airplane supplies. Balsa stock is 18" long. Sent postpaid for 25c., five bundles for \$1.00.

If you wish our price list only send 2c stamp. Here is a sample of our prices on balsa 1/2" x 1/8" x 36" at 1c per piece.

**AERO SHOP**  
 3050 Hurlbut Ave. Detroit, Mich.



We have had the first and still have the only complete scale model railroad catalogue in this country. Be sure and get a copy, 35c with credit slip good on your first order.

**AMERICAN MODEL RAILWAY CO.**  
 30 Avon Road New Rochelle, N. Y.

one-fourth as much as water is necessary for the normal-powered engine. This requires a radiator of proportionally smaller dimensions. Less head resistance is offered and more speed is consequently gained. In addition, the higher boiling point permits higher engine speeds which mean more power per pound. The weight gained by less cooling liquid and a smaller radiator amounts to well over 100 pounds. It remains to be seen to what extent Prestone will be used.

It appears probable that heavy duty airplane engines of 800 horsepower and over will continue to be of the water or liquid cooled type. The generation of so much power creates a great deal of excess heat which must be carried away. An air-cooled engine would need to be of impossible dimensions to provide for suitable cooling. In addition, when huge planes become veritable flying wings, their engines will be placed inside the wing foils. The shape and cooling system of the water-cooled engine appears to fit this demand better than the air-cooled engine as we now know it.

The Diesel engine is looming up on the horizon as a healthy competitor of the gasoline engine. Many attempts have been made to apply the Diesel to the airplane, but the recent Packard engine is the first successful attempt. The weight of the heavy-oil engine has always been a drawback. Packard, however, has succeeded in producing an engine which weighs about 2.5 pounds per horsepower.

No ignition is necessary in this type of engine. The heat of compression is sufficiently high to ignite the fuel vapor. This process continues indefinitely until the supply of fuel is exhausted or discontinued.

Heavy fuel oil is used. This is cheap and the supply unlimited. In order to vaporize the heavy oil the fuel is shot into the cylinder under heavy air pressure. Each cylinder is in effect an entirely separate engine. If for some reason it should fail to operate, it will not affect the remaining cylinders. Spark plug troubles are automatically removed. Difficulty with radio sets in planes will be eliminated because of the absence of the waves generated by the spark plugs and magnetos.

Economy of operation is assured because of the cheapness of the fuel. Further, the fuel consumption is twenty percent lower than that of the gasoline engine. This appeals to the transport operator who must figure his expenses down to cents. A plane equipped with this engine was recently

flown from Detroit to Florida. The flight was made in a little over ten hours and the fuel for the trip cost only eight dollars and fifty cents. The same trip with a gasoline engine would have cost not under thirty dollars. Enlarge these figures many times to the mileage of a transportation company and one realizes the economy which results from the Diesel type of engine.

The problem of starting the Diesel offered some difficulty at first. Its high compression offers considerable resistance to the starting agency. At last it was decided that the conventional type of inertia starter was the best solution to be found. As an aid to starting in extremely cold weather, a glow plug is provided in the number one cylinder. This is merely a plug of dissimilar metal which screws through the cylinder head. It projects inside the explosion chamber. The outside of the plug is heated by a blow torch. The heat works on through the plug until the inside point is incandescent. Then, as the engine is turned over, the incoming fuel is ignited by the glow plug. The resulting heat of compression is sufficient to keep the engine turning over. The fuel pump appears to be most susceptible to weakness in this type of engine.

The Pratt and Whitney Company recently modified one of their Wasp engines so that it can burn anything from gasoline to furnace fuel oil. The carburetor system was removed. In its place was substituted a small fuel pump for each cylinder. This new principle still uses the spark plugs for igniting the charge of fuel. The new Wasp gains power per weight on the Diesel, but it will still have radio difficulties due to the retention of the ignition system.

In the future more power for weight will be obtained by increasing the engine revolutions. Generally speaking, efficiency is gained by increasing the engine speeds. On the other hand, propeller efficiency is best at a speed of about 1,200 revolutions per minute. To combine these two opposites a reduction gear is necessary. Though power is gained, weight is added, and this installation will probably be used only on heavy duty airplanes. A second solution for this is in a variable pitch propeller which the pilot can operate from the cockpit. This device appeared and has been more or less successful on its initial tests. As yet, it has not been placed on the market. Some type of turbine engine may yet appear to sweep all the present known engines out of aviation.

**DON'T BE MISLED!**

There is only one MODEL AIRPLANE NEWS!  
 Reports and rumors to the effect that this magazine has merged with another publication are entirely without foundation.  
 MODEL AIRPLANE NEWS has not merged, nor has it the intention to merge with any other magazine.  
 Don't be misled by titles in which the words "Airplane News" appear. Ask for MODEL Airplane News—using the word "Model" to distinguish it.

THE EDITOR.



# Course in Airplane Designing

(Continued from page 32)

time as it starts. When the propeller first begins to revolve one can see the water being pushed away behind it. Then the boat begins to move forward, always pushing back on the water. That is the secret of movement. There can be no motion when there is nothing to push against.

We have seen that the airplane propeller moves the plane through the air by pushing back on the air, and have compared the propeller to a screw. Why, then, is not a propeller shaped like a screw, or, in other words, why does it not look like a huge spiral of metal or wood with a shaft through the middle? Simply because the air is a fluid medium.

If it were solid, like wood, the propeller would be like a screw, with lots of surface with which to get a grip. However, the air is not solid—and that is where we find the difference between the propeller and the wood screw that we used to explain the basic principle of the thing.

Since the air is fluid, and comparatively light, we must move a great amount of it per minute in order to obtain a strong thrust force. To do this it would obviously be useless to make a propeller in the shape of a screw, as has actually been done by a few designers of "freak" machines who knew nothing of aerodynamics, since this type of screw is intended for getting a grip on a solid medium.

Instead we make a propeller of large diameter, so that it will move a lot of air, and turn it at a fairly high rate of speed. So far, then, we have a propeller that is but a segment of a spiral screw; one that has narrow blades, nearly flat.

Now we come to the refinements. We have learned, from our study of air flow in the earlier articles of this course, that a wing will produce a great deal more lift if it is curved instead of flat. We apply this to our propeller, since a propeller is nothing more than two wings attached to a shaft, and we find that the blades, when given the cross-section of a wing curve, produce much more thrust than if they were left flat.

The term *thrust* is used here to distinguish it from the lift of the wings, but in reality the thrust force is exactly the same as the lift, with the exception that it acts along the horizontal axis of the ship.

You have, no doubt, noticed that the blade angle of a propeller changes constantly from the hub to the tip. As shown in Figure 1, the *blade angle* is the angle between the chord line of the blade and a plane at right angles to the propeller shaft. However, why does the angle change, being very much larger at the hub than it is at the tip? To explain that we have to imagine a propeller in flight. The propeller is rotating and moving forward at the same time, but the tips of the blades are cutting through the air at a much higher speed than are the portions nearer the hub.

This can be illustrated by taking the case of a runner on a circular track making, say, three trips around per minute. If we increase the diameter of the circle it is evi-

dent that he will have to cover the ground faster to keep up the number of trips per minute. Conversely, if we cut down the size of the circle until it is very small, he will be able to make the three trips per minute at an easy walk.

The same thing applies to the propeller. When the prop is turning over some 1,800 revolutions per minute (R.P.M.) we find that the tip is travelling at a very great speed, while the portion near the hub is moving at a much slower rate. When I speak of speed in this sense, I mean speed of rotation, or speed around the circle, and have no reference to the forward motion of the ship. The differences in speed of the various parts of the propeller blade may be figured out very easily by finding the circumferences of the various circles in which the portions travel. It will be seen that the difference in speed of the tip and the part near the hub is surprisingly great. Keep that in mind.

Now we imagine our propeller moving forward through the air as it rotates. Does it not stand to reason that the tip, which is travelling very rapidly in its circle, will be operating at a higher angle of attack, providing the blade is of constant pitch angle from hub to tip, than the hub portion is? A little thought will show that to be true; and since it is true, we would have the hub portion operating at a small angle of attack and the tip working near the stalling angle.

The remedy, then, is to make the pitch angle constantly decrease as we go toward the tip, having it relatively large near the hub, where the rotational velocity is small; and small at the tip, where the rotational velocity is very large. Thus we have our blade operating, as nearly as possible, at a constant angle of attack throughout its entire length.

An important point to remember is that the propeller, when the ship is in flight, is not operating at its pitch angle. The ship is moving forward rapidly, and this naturally decreases the angle at which the propeller blade does its work.

It would be a good idea for readers to go to an airport and take a good look at some propellers. Wooden ones are the best for this study. Notice how the blade angle decreases constantly from hub to tip, and notice how the blades are shaped. However, when examining a prop in this way, never turn it. Someone may have the switch on, and it's a whole lot better to be careful than to have an arm broken.

We have spoken of the great difference in the speeds of the various parts of the propeller blade. The speed of the tip portion, or *tip speed*, as it is called, is the governing factor in racing propeller design. We can build motors that will turn propellers up to very high speeds, but when we do that we find that the props, for aerodynamic reasons, become inefficient, and also the material from which they are made can stand only so much strain. So, for most uses, high-speed motors are geared down so that their propellers may operate at more efficient speeds.

## Boys! Here's the Plane THE "FLEETWING"

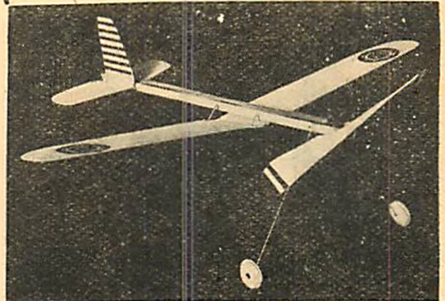

A real flying, all Balsa Monoplane—No kit but a Model Plane ready to fly. R.O.G. type with 14 inch wing span just as shown in the picture.

Sturdy enough to stand the bumps yet light enough to have all the flying qualities—1/5 ounce.

Built by an outstanding Model Engineer of over ten years experience in Model building and flying.

The "Fleetwing" is decorated in a beautiful red with black insignias—a marvel in the air. See the astonishingly low price in the coupon.

### YOU CAN BUILD YOUR OWN



from the "Fleetwing" kit. Every piece necessary for assembling—nothing to cut—all balsa parts made to size but not decorated—all spring steel wire parts correctly formed ready for use—perfectly cut propeller already pierced—highest grade celluloid wheels.

A full set of drawings and easy to understand instructions in every kit at a price you can't afford to turn down.

Any boy with or without experience can fly the "Fleetwing" or build one from these ready formed parts.

Be the first in your neighborhood to fly this little wonder. Fill in the coupon and mail it today.

The Canton Miniature Aircraft Corporation,  
1600 Fourth St., S. E., Canton, Ohio.  
Gentlemen,—

Please send me by return mail the items checked below for which money order is enclosed.

( ) The "Fleetwing" Monoplane ..... \$ .55

( ) The "Fleetwing" Kit ..... .50

( ) Catalogue of Models and Supplies—No Charge.

City..... State.....

Street Address.....

Name.....

## BARGAINS!

- 1/32x2", 24" long ..... .04c
- 1/16x2", 24" long ..... .05c
- 1/8x2", 24" long ..... .06c
- 1/32x3/32", 24" long ..... 3 for .02c
- 1/16x1/16", 24" long ..... 3 for .02c
- 1/8x1/8", 24" long ..... .01c

Orders under \$1.00 add 10c for postage.

Send 2c stamp for price list.

DALLAIRE MODEL AIRCRAFT CO.

10140 Grosvenor Ave., Detroit, Michigan.

## BIG-BANG CELEBRATORS

SEND FOR FOLDER

The Conestoga Corporation  
Manufactured and Patented  
Bethlehem, Pa., U.S.A.

with a real FLASH and BANG

THE CONESTOGA CORP.  
BETHLEHEM, PA., U.S.A.



# Smashing Records!

IT'S A HABIT! U. S. MODELS  
Walk Away With All Prizes.  
This 20" Curtiss Robin  
Proves It—Fly? Well  
Boy! Build One.



NEW! U. S. Lockheed Sirius, Boeing P12B—Both Flying Wonders. Send 10c for large 56 page catalog. Describes 26 models—1000 parts.

**FREE! OUR NEW 12 PAGE FOLDER**  
**U-S-MODEL AIRCRAFT CORP.**  
397 BRIDGE ST., BROOKLYN, N.Y.

## "BARGAIN PRICES"

On Model Airplane Supplies, compare these prices with others and order your supplies direct. We pay postage in U. S.  
Pure Para Rubber, fresh stock, 2 feet for..... .01  
Full Skins, 225 feet ..... .95  
Piano Wire No. 12-16-20, 2 feet for..... .01  
1/2 Brass Washers, 1 doz. 4c, 2 doz. .... .07  
Hakone Tissue, 21x31, 3 sheets..... .10  
3/16 Aluminum Tubing, per foot..... .05  
2" Star in Circle, 2 for..... .08  
Thrust Bearing, light and strong, 3 for..... .08  
New 1931 Catalog ..... .05  
Send Money Order, Draft, or Check.  
Stamps up to 25c. No. C.O.D.  
"COMING" The New "Red Bird Line of Models."  
**RED BIRD MODEL AIRPLANE & SUPPLIES**  
1615 Maple St., Omaha, Nebr.

## NEW SCIENTIFIC WONDER



**10c** 3 for 25c **BIG FUN**  
**BOYS** You apparently see thru Clothes, Wood, stone, any object. See Bones in Flesh. FREE Pkg. radio picture films, takes pictures without camera. "You'll like 'em." 1 pkg. with each 25c order. Marvel Mfg. Co., Dept. 93, New Haven, Conn.

## FLYING CLUB PINS . . . 35¢



**FREE CATALOG**  
Design Shown silver plate 35 cents each, \$3.50 doz. Gold plate or sterling silver 50 cents each, \$5.00 doz. Made with any 6 letters or less; 2 colors enamel.

**BASTIAN BROS. CO. 969 Bastian Bldg., Rochester, N. Y.**

Get Ready For Spring and Summer Contests Now

## WHY ADVERTISED MODELS ARE BEST

No one knows exactly how many model airplane companies are in business today—perhaps five hundred. Of this number about fifty of the older and larger firms advertise their products. These fifty companies have large amounts of money invested in the model airplane business. And their profits on this investment depend on Your Satisfaction and Continued Support. These fifty large advertising firms are, therefore, most anxious to please you. You will find their models best.

### HERE YOU ARE, BOYS!

The plan of any plane you want for 10c. Travel-air Mystery Ship S.E. 5 British War Pursuit Lockheed Vega Express Fokker Amphibian, Sky Soarer, Sky Flyer, Sky Balder, Sky Pursuit, Sky Speedster, A 11 American Rocket Plane, as described in Popular Aviation. One plan and circulars for 10c.

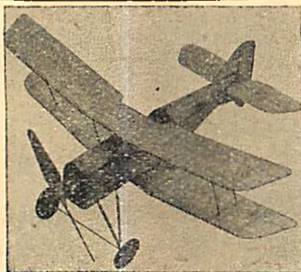

Eleven plans and circulars for \$1 bill. Knockdown 3-cyl. motor, \$1.75. Finished 3-cyl. motor, \$3.25. Air tanks to match. Insured by Air Commerce Reserve.

**AVIATION MINIATURE ENGINES**  
28 NORTH CLINTON ST., CHICAGO, ILL.

On racing ships, of course, we have a different problem. In this case the propeller has to turn up to a high R.P.M., for the reason that the ship is actually going through the air so fast that the prop blades have a hard time keeping up! On racing jobs, such as those used in the Schneider Cup races, it has been found best to use a propeller of fairly high pitch angle, so that it will be able to preserve a fair angle of attack at speeds of three hundred miles an hour and upward.

I have been speaking of pitch at various times in this article, and it is time that we learn something of this very important matter. Pitch, as I have said in reference to the screw, is the distance that the screw moves forward in one complete revolution. However, when we apply this to the airplane we find a slipstream behind the propeller, which shows that the air is being pushed away behind the blades, thereby making it impossible for the prop to move as far in the air as it would if it were cutting through a solid medium. For airplane propellers, then, we have two pitches, *theoretical* and *actual*.

We will deal first with *theoretical* pitch. This is the distance that the propeller would move forward if there were no slip; that is, if the air did not give way and allow itself to be pushed back. The theoretical pitch may be determined rather easily by geometry. For the model builder's purpose there is a formula that gives the theoretical pitch, using only the dimensions of the blank from which the prop is made. It is:

$$D \times 3.14 \times T$$

W

$$= \text{theoretical pitch}$$

In the above formula, D stands for the diameter of the prop (the length of the blank), 3.14 is the familiar constant dealing with the relation between the diameter of a circle and its circumference, T is the thickness of the blank, and W is the width of the blank. To determine the theoretical pitch of a propeller, then, we multiply the diameter by 3.14, multiply the result by the thickness of the blank, and divide the answer by the width of the blank.

As an example, we will find the pitch of a 12 inch prop, cut from a blank an inch wide and half an inch thick. We can set up the problem by substituting the values in the formula.

We have:

$$12 \times 3.14 \times 0.5$$

1

Working this out, we get the pitch, about 18.8. The answer is in inches, since all our values were in inches, and therefore we know that, theoretically, the prop would move forward about eighteen inches for every revolution.

However, we know that it does not. The slip comes into consideration, if we wish to determine the actual pitch. This cannot be done precisely, since no two props are exactly alike in efficiency, but for the average prop we can take the efficiency as eighty per cent.

This means that it will move about eighty per cent of the theoretical pitch per revolu-

tion, assuming of course that the prop is turning up to a sufficient speed for it to get a grip on the air. The other twenty per cent is expended in pushing back the air, creating the slipstream. Taking the prop above, we find the actual pitch to be 18.8 x 80%, which is about fifteen inches. This last is approximately the actual pitch.

Using the actual pitch we can determine the speed of our ship with reasonable accuracy, provided we know the R.P.M., of the motor. It is of course dependent on the efficiency of the ship, since it is a lot easier for a propeller to move a streamlined, well-designed ship than it is for it to tug a bus that looks more like a barn door than an airplane—another argument for careful design and efficiency, especially in model airplanes.

In model work we have several problems that are distinctly our own. Using rubber motors, for example, we want the motor to run as long as possible, providing sufficient thrust at the same time. A low pitch propeller, however, tends to turn over rapidly, perhaps even to "race," and the motor is soon unwound. This brought about the "slow prop" model airplane.

The idea of the slow prop is to conserve the power of the motor as long as possible, and to do this the propeller turns over slowly, moving the ship through the air at a low rate of speed, thus increasing the duration. We use a propeller of fairly high pitch and large diameter, which operates at a high angle of attack at all times and holds back the motor. These have been found very satisfactory.

Many times one hears the question, "Why do they use propellers with three or four blades?" As we have seen, the object of the propeller is to move a great deal of air to produce thrust. It has been found that a two-bladed propeller, having a large diameter, is the most efficient for this purpose. However, there are times when a two-bladed propeller, when used on a very powerful motor, has to be made so long that it takes up a lot of space. This is especially true of flying boats, as shown in Figure 2. In this case economy of weight and drag is obtained by using a three or four-bladed prop, which will make use of the full power of the motor without having such a large diameter. That is the why of three and four-bladed propellers.

Sometimes it is argued that multi-bladed props are actually more efficient than the usual kind, but this has been pretty well disproved. Some builders of freak machines take the thing further, using props that look more like electric fans than anything else, having literally dozens of blades. These have been excellent when used in fans, where they produce as much slipstream as possible with very little thrust, but that is exactly the opposite of the goal in airplane design.

There is, however, a great field for research in the field of propeller design. Our present propellers are not as efficient as they might be, and moreover they are noisy. The man who discovers a new principle, and a sound one, which will make our propellers more efficient and quiet, will find himself in an enviable position.



# Why Pay More When You Can Get the "Best" of Quality and the "Lowest" of Prices By Buying Direct From Madison Model Airplanes, Inc.

You'll say, "How can they do it at these lower prices?"—You'll be amazed! astonished! when you make comparisons. The extra fine quality of the merchandise we sell you will be an added inspiration to you to build an extra ship—and our lower prices will let you do it. Don't wonder or guess why we are able to "sell for less"—the answer is a simple one: Madison Model Airplanes' popularity is growing so rapidly that "mass production" is the sole reason for our lower prices. Boys all over the country who are building the "better models" now-a-days are doing it with Madison Model Airplanes' Better Materials at Lower Prices!

## A FEW EXAMPLES OF OUR LOWER PRICES

|   |               |
|---|---------------|
| <b>BALSA WOOD</b>                                   |               |
| Our Balsa is the lightest and best balsa to be had. |               |
| <b>36" STRIPS</b>                                   |               |
| 1/16 x 1/16 .....                                   | .01           |
| 1/8 x 1/8 .....                                     | .01½          |
| 1/8 x 3/16 .....                                    | .02           |
| <b>SHEET BALSA</b>                                  |               |
| 1/32 x 2 x 36 .....                                 | .06           |
| 1/16 x 2 x 36 .....                                 | .07           |
| 1/8 x 2 x 36 .....                                  | .08           |
| <b>BALSA PROPELLER BLOCKS</b>                       |               |
| 1/2 x 3/4 x 6 .....                                 | .02           |
| 5/8 x 1 x 7 .....                                   | .2 for .05    |
| 5/8 x 1 x 8 .....                                   | .03           |
| <b>CLEAR DOPE</b>                                   |               |
| 2 oz. can .....                                     | .14           |
| <b>COLORED DOPE</b>                                 |               |
| 2 oz. can .....                                     | .17           |
| <b>ACETONE</b>                                      |               |
| 4 oz. can .....                                     | .25           |
| <b>AMBROID</b>                                      |               |
| 2 oz. can .....                                     | .20           |
| <b>COLORLESS CEMENT</b>                             |               |
| 2 oz. can .....                                     | .20           |
| <b>MADISON "ACE" RUBBER</b>                         |               |
| .045 square .....                                   | 3 ft. for .01 |
| 1/8 flat .....                                      | 5 ft. for .02 |
| 3/16 flat .....                                     | 3 ft. for .02 |
| <b>THRUST BEARINGS</b>                              |               |
| .035 hole. Each .....                               | .03           |
| Small size, .025 hole. Each .....                   | .03           |
| <b>WASHERS</b>                                      |               |
| 1/8 O. D. per doz .....                             | .02           |
| 1/4 O. D. per doz .....                             | .02           |
| <b>MUSIC WIRE</b>                                   |               |
| Sizes .014, .020, .028, .034, .....                 |               |
| 5 ft. packages .....                                | .02           |

## FREE PLANS

FOR  
HIGH-PERFORMANCE R.O.G.  
SENIOR R.O.G.  
11-MINUTE INDOOR TRACTOR

If you write and ask for Our Complete List of Lower Prices.

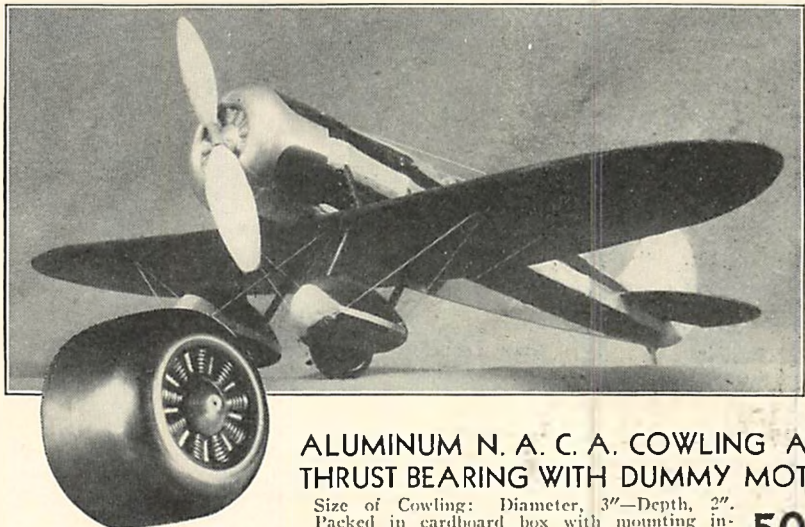

ALUMINUM N. A. C. A. COWLING AND THRUST BEARING WITH DUMMY MOTOR

Size of Cowling: Diameter, 3"—Depth, 2". Packed in cardboard box with mounting instructions. If ordered separately, add 5 cents for packing and postage. **50c**

## Special OFFER

Buy any TWO kits on this page and receive without additional cost the beautiful N. A. C. A. Cowling above.

## TRAVEL AIR "MYSTERY SHIP"

(Pictured Above)

Build a model of the famous record-breaking Travel Air Mystery Ship and treat yourself to a thrill that comes but once in a lifetime. We sincerely believe that this kit is the finest in the entire model making field, and when you see it, we are sure that you will agree with us. Nowhere else can you get the superb value offered in this kit. It contains an aluminum N. A. C. A. cowling pictured above, full size plans and specifications, celluloid wheels, easy-to-form wheel pants, 2-oz. can red model dope, extra large tube colorless cement, extra light covering tissue, and many other features. Order yours NOW! The price is only

24 Inch Flying Model

**\$2.50**

## RECORD BREAKING OUTDOOR MODELS

### Outdoor Cabin Tractor

One of the snappiest flying models in its class! Proper engineering and all balsa construction does it. This plane has a double surfaced, high lift wing—30 inch span, all balsa triangular fuselage, extra strong landing gear to withstand the shocks of outdoor flying, and a large, wide bladed prop to keep it up for long duration flights. Kit contains plans, instructions, and all materials needed to complete this wonderful model. Price...

**\$1.50**

### Twin Pusher

A twin pusher that has actually flown over 12 minutes not once—but several times!! This plane contains many features that cannot be found elsewhere. It has a 40 inch "A" frame that is a marvel for lightness and strength, 36 inch, high cambered, tapered wing, two 12 inch, high pitch props, powered by 68 feet of ¾ flat rubber. The kit contains more than enough materials for the construction of this record breaker. Price.....

**\$1.50**

## THREE-IN-ONE KIT

Here are those flying stick models you've been wanting to build for a long time. No matter how many of these you've built already, you're sure to get a kick out of these light, high-performance models. This kit contains plans and instructions and all materials necessary to build a HIGH-PERFORMANCE R. O. G., a SENIOR R. O. G., and a new 11-MINUTE INDOOR TRACTOR. The price for these three models is LESS than some companies are asking for the last plane alone. Three-in-One Kit .....

**\$1.00**

Highest Quality—Fastest Service—Lowest Prices

MADISON MODEL AIRPLANES, Inc., 138 Livingston St., Brooklyn, N. Y.



# ALL Balsa—AMERICA'S MOST EASILY! CONSTRUCTED MODELS!

A new, all-balsa construction makes these Midland models superior to anything you have ever seen. Lighter—about two-thirds the weight of an ordinary model of the same size. Stronger—practically crash-proof. Better-looking and more realistic—smooth, sheet-balsa surfaces instead of wrinkled tissue sagging between ribs and long crons. Easier to build, because so much simpler. A job you can do in a couple of hours instead of a week. And you can do it. We've eliminated the question of skill.

Midland's all-balsa construction makes use of sheet balsa 1/32 of an inch thick for the wings and the sides of the fuselage. Balsa—almost

as light as the paper it replaces, and infinitely stronger! The only paper is that used to cover the top and bottom of the fuselage and the tail.

No fragile, tedious built-up framework. Nothing to draw. Nothing to measure off. No nails to drive, no holes to drill. A ready-made, die-stamped aluminum propeller to save you the work of carving one and to prevent the failures due to poorly-made propellers. Struts of spruce and bamboo. Celluloid wheels, light and good looking. A shock-absorbing landing gear. Colorless, quick-drying model cement—the fastest-drying known. Rubber 10% more powerful. Landing wheels well forward to protect the pro-

PELLER. Wings at a high angle of incidence for fast climb and minimum center of pressure travel. Tips "washed out" to reduce losses. Scores of other aerodynamic refinements seldom found in models.

You will find these models much easier to build, and, after you have built them, much more satisfactory to fly. Fewer trial adjustments longer steadier flights.

THE MIDLAND MODEL WORKS

Box W,

Chillicothe, Ohio

## TAPER-WING COMBAT MONOPLANE— An Unusual Value

An exceptionally graceful model of a center-wing combat monoplane, and the best distance flyer of the Midland group. Does 200 feet consistently. Can be hand launched or will rise off ground. Very easily built, and will stand hard use. Wing span 20 inches. Weight 8/10 ounce.

Complete set, with all material and full building and flying directions, postpaid in the United States and Canada ..... **\$2.00**

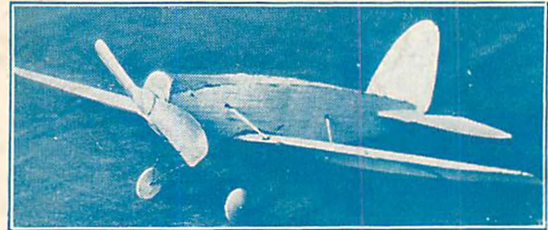
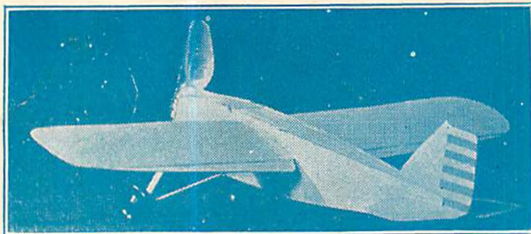

## MIDLAND BABY BULLET

Wing span 15 inches. Weight 3/8 ounce. Flight range 140 feet or more.

A simple, easily-constructed r. o. g. model of a one-place low-wing sport plane. The propeller is only one-fourth as long as the wings, and much closer to true scale than in ordinary models. Propeller blades deeply curved for slow revolution and unusual duration.

Complete set, with all material and full building and flying directions, postpaid in the United States and Canada, only..... **\$1.00**

Midland Army Biplane in Flight



Unretouched photograph

## 1 OUT of 10

Probably not one model airplane in ten ever gives its purchaser a satisfactory flight. Some failures are due to careless construction. Some are due to careless design—a carelessness sometimes so great that the model can not be made to fly under any conditions. But the majority of failures are due to the tremendous difficulty encountered in building many models.

The average model would be entirely satisfactory if it could be constructed with less skill, but it may be a sad disappointment to the ordinary model builder, who often finds that he has wasted both his money and his time on a set which only an expert can put together.

A simple and easy construction is the key-note of Midland design. We do not pretend that Midland models are exact scale reproductions, for such models are hard to build, unsatisfactory to fly. We do not claim that these models will break records, for record-breaking models are too delicate to build, too fragile to last. All that we say is that these models are pleasingly realistic, that they will fly well time after time, and that the average boy can build them. Why risk disappointment by purchasing a model advertised with extravagant claims of exact scale design and almost unbelievable flying ability? Buy a Midland model and get what you expect, and what you are entitled to have.

You are doubly safe in ordering Midland sets because nothing but actual, unretouched photographs are used to advertise them. Remember that any photograph of a Midland model shows it as you will get it—not merely as you would like to have it.

## REALISTIC ARMY BIPLANE

This fast biplane fighter is a tremendously impressive model. Its trim fuselage and tapered, close-set wings give an impression of speed, and in the air it looks so much like a real ship that flight photographs of the model are usually mistaken for pictures of a full-sized airplane.

The wing spread is 20 inches, the weight exactly 1 ounce. The flight distance is close to 200 feet. Because of its greater wing area, the Army Biplane gains a great deal of altitude. The average limit is about 50 feet, but we have photographed it when almost three times that high!

The top wing is in advance of the lower one, and at a larger angle of incidence. This results in the center of pressure of both wings being shifted forward when the model dives, back when it climbs. This is the exact opposite of the usual movement and gives the model unequalled stability. By far the best rough-weather flyer we have seen.

Harder to build than the monoplanes, but still much easier than any conventional built-up model. Complete set, with all material and full building and flying directions, postpaid in the United States and Canada. **\$2.50**

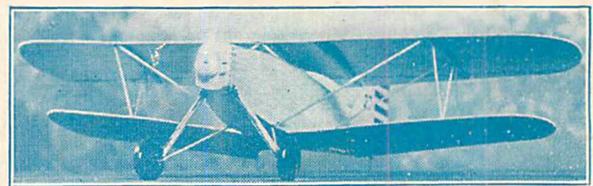

## ORDER NOW—USE THIS COUPON

The MIDLAND MODEL WORKS, Box W, CHILLICOTHE, OHIO

Gentlemen:

Enclosed find \$..... for which send me your construction set for ( ) BABY BULLET ( ) COMBAT MONOPLANE ( ) ARMY BIPLANE. I understand that these sets will be sent postpaid in the United States and Canada, and that you guarantee any properly constructed model to fly as stated.

Name .....

Street .....

City..... State.....