

MODEL AIRPLANE NEWS

APRIL 1948

25 CENTS

GRUMMAN PANTHER



IN THIS BIG ISSUE! • Chockful of PLANS for: Unusual Tailless Rubber Model..Free Flight Gas .. Class C Towline • ALSO—Latest Radio Control & License Data .. Helpful Hints on Glow Plug.. How to Check Engine Horsepower.. Wylam Masterplans.. C. H. Grant ..Bill Winter's Scrap Box.. W.W.I .. Club News.. West Coast Tips.. Big Plane News.. Etc.

Digital Edition Magazines.

This issue magazine after the initial original scanning, has been digitally processing for better results and lower capacity Pdf file from me.

The plans and the articles that exist within, you can find published at full dimensions to build a model at the following websites.

All Plans and Articles can be found here:

Hlsat Blog Free Plans and Articles.

<http://www.rcgroups.com/forums/member.php?u=107085>

AeroFred Gallery Free Plans.

<http://aerofred.com/index.php>

Hip Pocket Aeronautics Gallery Free Plans.

http://www.hippocketaeronautics.com/hpa_plans/index.php

Diligence Work by Hlsat.





Enters the Free-Flight

and U-Control Field with 2 Great Flying Model Kits

\$7⁵⁰

FG-1

(FREE-FLIGHT GAS MODEL KIT No. 1)
CLASS A OR B

SPECIFICATIONS

Overall Length..... 32"
Wing Span..... 50"
Projected Wing Area..... 353 sq. in.

A superbly-engineered kit with 36 pages of illustrated instructions that provide a new approach to legible, easy-to-follow plans.

\$4⁰⁰

PC-1

(PRECISION CONTROL-LINE MODEL KIT No. 1)

LICENSED UNDER JIM WALKER U-CONTROL,
UNITED STATES PATENT No. 2,292,416

SPECIFICATIONS

For Engines .23 to .36 cubic inches displacement
Wing Span..... 36"
Overall Length..... 30"

Top Maneuverability with Class B Engines

MATCH-MATES FOR

TOP PERFORMANCE

"O. K." HOT-HEAD
ENGINE

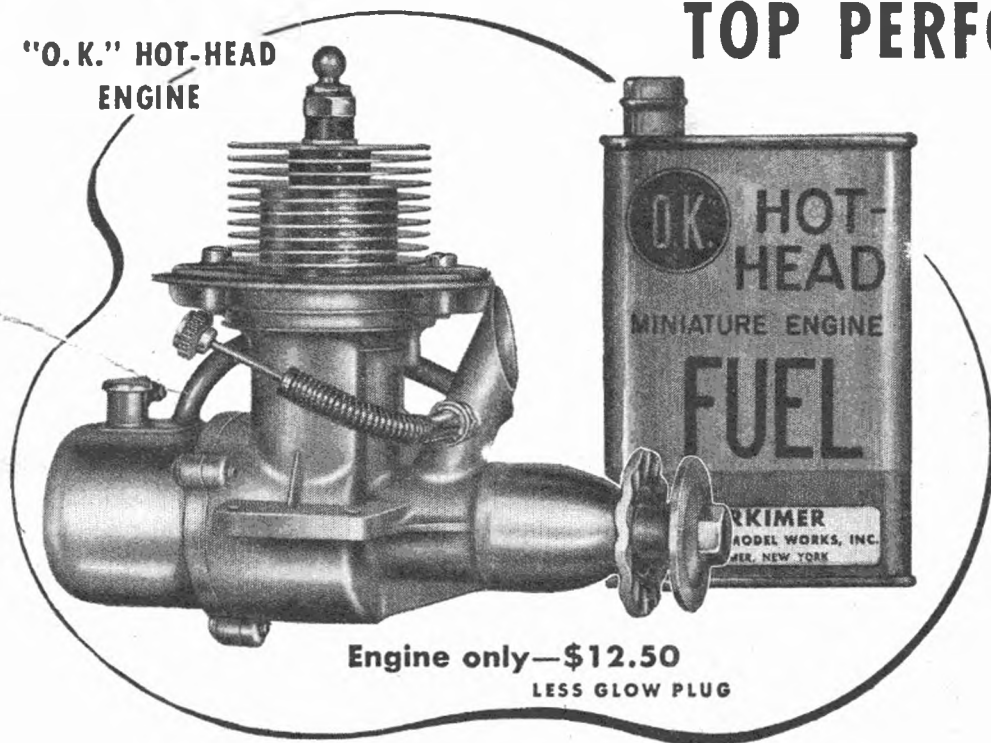

Engine only—\$12.50
LESS GLOW PLUG

The PERFECT
COMBINATION
for FAST STARTS
and
HIGHEST
SPEEDS

What a team they make !

The sensational, new "O. K." Hot-Head engine has already set new performance standards for Glow Plug operation. Now, even greater records are in the making with the introduction of "O. K." Hot-Head Miniature Engine Fuel, expressly formulated to bring out the best in the new Hot-Head engine.

Developed in the "O. K." laboratories, the new fuel is the result of more than two hundred individual performance tests. The finished formula was found to produce *substantially* more power than any other fuel intended for Glow Plug operation. So, if you want the best in performance — insist on these great power partners.

Not a conversion model but a completely new design, the "O. K." Hot-Head engine is built to take the unusual stresses peculiar to Glow Plug operation. It features an extra heavy crankshaft .406" in diameter, a drop forged, heat-treated connecting rod and a bronze main bearing, 1 $\frac{5}{8}$ " long.

Don't take a chance of ruining your present conventional ignition type engine by conversion as the average engine of this type will not perform satisfactorily nor is it built strong enough for Glow Plug.

The "O. K." Hot-Head is so simple to operate that all you have to do is connect a 1 $\frac{1}{2}$ volt battery to the Glow Plug until the engine starts. The battery is then disconnected immediately and the engine will continue to run on pre-ignition firing.

The Glow Plug itself can be purchased at your favorite hobby shop for 85c.

ENGINE SPECIFICATIONS

DISPLACEMENT — .299, B CLASS BORE — .760
R. P. M. — (WITH HOT-HEAD FUEL ONLY) TO 11,000
STROKE — .660 WEIGHT — 7 OUNCES

HERKIMER Tool and Model Works, Inc., Herkimer, N.Y.
CANADA: Herkimer "OK" Engine Co., 511 Hermant Bldg., Toronto
EXPORT: 120 Wall St., New York 5 (All Cables) Concordia, N. Y.

MODEL AIRPLANE NEWS

JAY P. CLEVELAND
Publisher

Serving Aviation 19 Years

APRIL 1948

VOL. XXXVIII No. 4

CONTENTS

Cover Design by Joe Kotula

FREE FLIGHT RUBBER

Williwaw 9

FREE FLIGHT GAS

Skipper..... 16

GLIDER

A Class C Towliner 25

WYLAM MASTERPLAN

Clerget Rotary Engine 22

PLANE ON THE COVER

Grumman Panther 15

SCIENCE

Checking Horsepower 12

The Ancient Glow-Plug 19

Design Forum 24

Meet the Rudevator 28

Inertia Starter 32

Tester for Model Sparkplugs 33

WORLD WAR I

Breguet Biplane 23

3 VIEWS

Grumman Panther 14

French Farman Biplane 1914 36

German Halberstadt CL-2 of 1917 38

NEWS

Flash 2

The Scrap Box 8

Modeling in Flying Schools 20

Airways 30

West Coast Tips 34

Latest on Radio Control Licenses 36

News of Modelers 43

Club News 44

HOWARD G. McENTEE Editor

JOSEPH M. MANN Managing Editor

WILLIAM A. WYLAM Associate Editor

WITTICH HOLLOWAY Art Director

JAY P. CLEVELAND Adv. Manager

A. M. HOFFMAN Asst. Adv. Manager

Advertising Representative, WEST COAST: Justin Hannon,
5429 Crenshaw Blvd., Los Angeles 43, Calif.

Published monthly by Air Age, Inc., Mount Morris, Illinois. Editorial and Advertising offices: 551 Fifth Ave., New York 17. Jay P. Cleveland, President and Treasurer; A. M. Hoffman, Sec'y. Entered as second class matter Dec. 6, 1934 at the post office at Mount Morris, Ill., under the act of March 3, 1879. Additional entry at New York, N. Y. Price 25c per copy. Subscriptions \$2.50 per year in the United States and possessions; also Canada, Cuba, Mexico, Panama and South America. All other countries \$3.00.

Copyright 1948 by Air Age, Inc.



COMPLETION OF studies by the President's Air Policy Commission promises a genuine "shot in the arm" for U.S. aviation. The Commission was made up of private citizens, presumably without special knowledge or interests in aviation, to insure an unbiased study and a citizen's view of the situation. Their findings, generally, are that the U.S. taxpayer must begin paying considerably more for aviation, and most of this money must go into military aviation to provide this nation with a vastly improved defense. First of all, the Air Forces and Naval Aviation must buy more airplanes each year, at least 30 million pounds of airframe this year and 40 million next year. (Present rate is about 20 million pounds a year.) This increased production will accomplish two things: (1) it will give the Air Force its 70-group program (only 55 are presently activated, many of them only skeleton forces) and the Navy its program for existing carrier air groups; and (2) it will provide the aircraft industry with the essential minimum level of production necessary as a base for a rapid expansion in the event of an emergency.

THE COMMISSION'S strongest recommendation is for legislation permitting the obligation of funds for a minimum of five years (instead of the present annual appropriation of funds for each fiscal year) which would permit planning of long range projects. It would also facilitate long range basic research projects and the development

of complex weapons now only in the design stage.

REMAINING TO BE heard from however is the Congressional Air Policy Board, made up of Congressmen and Senators, who have it within their power to appropriate and legislate their findings into law. Their report is expected to confirm many of the findings of the President's group but to go further in the way of requirements for strengthening the nation's defenses.

FOLLOWING UP these recommendations is Pres. Truman's 1949 Budget which asks for: a 35% increase over last year in Air Force funds, 42% increase for Naval Aviation, 30% increase for CAA, 10% increase for NACA, and a five-fold increase for airways communication equipment by the Army Signal Corps. Of the total armed services budget, 54% is for aviation, the remainder for combined ground and sea forces of the nation.

NEW ORDERS have rolled into the industry from the military so quietly as to be almost a secret. Chief of these are additional quantities of existing procurement types including: Boeing B-50, Douglas AD-1 Skyraider, Grumman F8F-1 Bearcat, Lockheed P2V Neptune, Vought F4U-5 Corsair, Martin PBM-5A, Piasecki, Bell and Sikorsky helicopters. New orders include 225 North American P-86 swept-wing fighters, 10 Douglas DC-6 and 20 Republic F-12 Rainbow photographic planes.

(Continued on page 62)

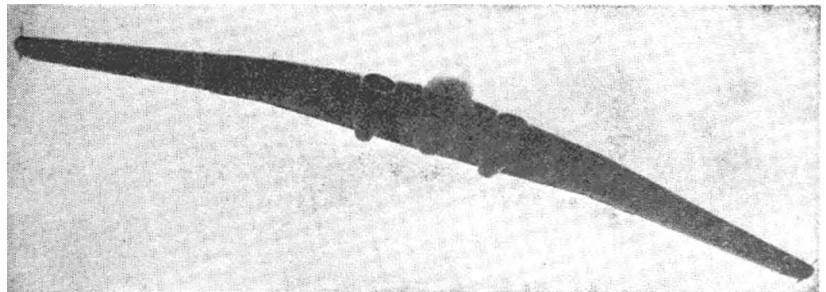

(Above) New British jet flying wing, the Armstrong-Whitworth AW52, as it made its first public appearance near Rugby, England. (Below) A real flying freight car—this Convair XC-99 military transport and cargo ship can carry 400 fully equipped troops or 100,000 lbs. of cargo

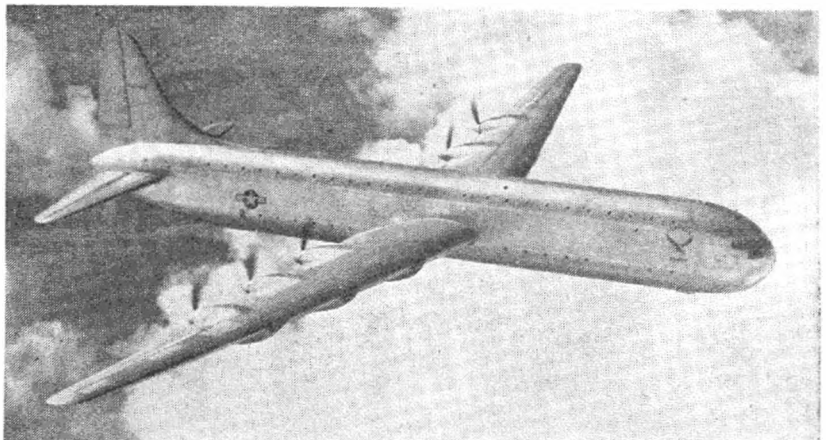

Control-Line Flyers!

Make Your Ship "TALK"

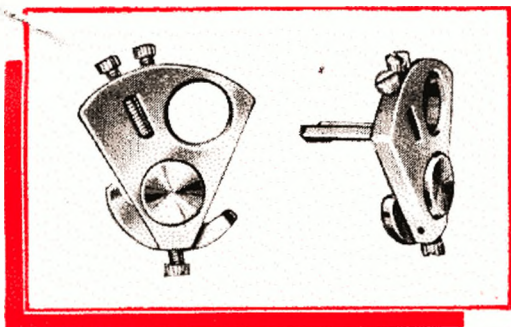

Here's What Red Wing
Engine Speed Control
Can Do . . .

FOR THE BEGINNER

Helps you learn to fly sooner by making possible several landings and take-offs per flight instead of the usual one.

Lets you break in your new engine while flying by changing occasionally to slow speed, which cools the engine.

Makes test hops possible — land for adjustment whenever necessary.

Permits landing at will. Safeguards your ship from crackups due to dizziness.

FOR THE EXPERT

Permits you to fly two ships at once without catastrophe.

Helps get those extra points at contests by such maneuvers as:

Smooth, tail-high landings

Pick up gliders, mail, etc.

Unassisted take-offs

Power-on landings

Spot landings

Power stalls

Lets you study your ship at slow-speed flying. Allows stopping engine of racing ship after clocking — eliminates unnecessary wear and risk.

Red Wing Engine Speed Control is a Complete Unit ready to install. No Accessories to Buy

DEALERS: Demand is growing — Order from your jobber now!

ATLANTIC AIRCRAFT INC.

213 Washington St., West Warwick, Rhode Island

RED WING

REQUIRES

- ★ No Battery
- ★ No Relay
- ★ No Third String
- ★ No Double Points

\$ 1.95

Price Only

Patent Pending
Patent will be protected to fullest extent of law



Now you can afford the finest!

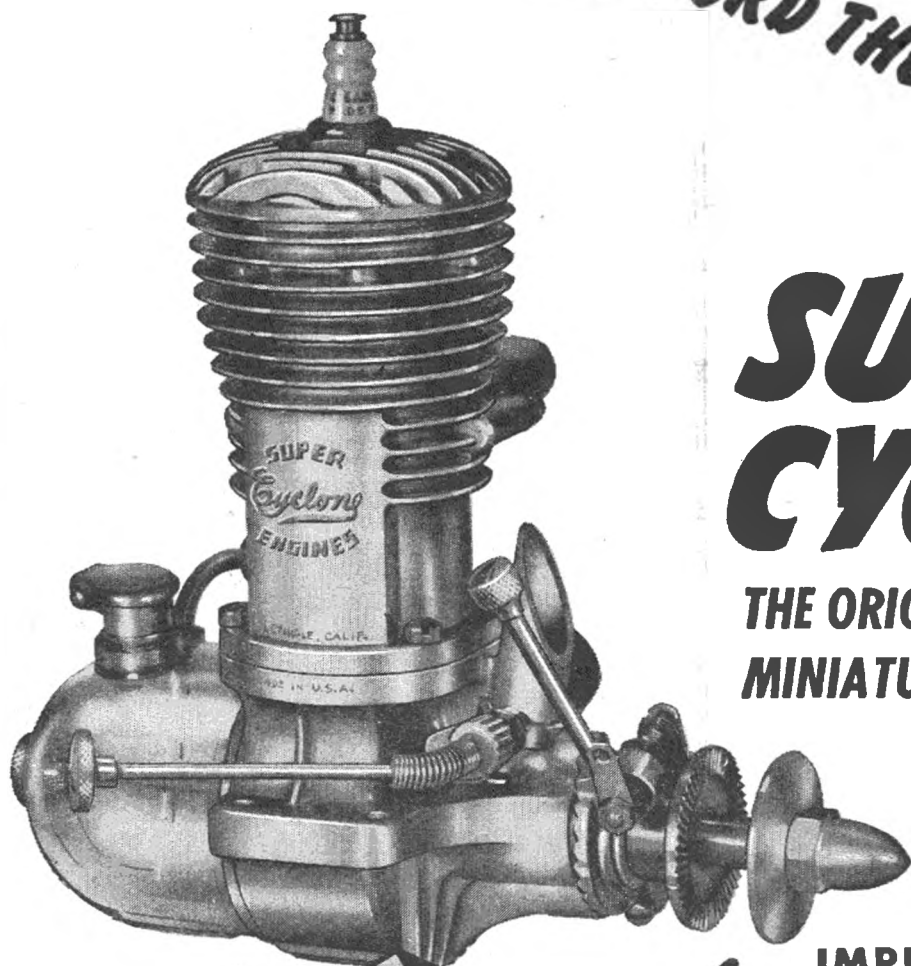

SUPER-CYCLONE

**THE ORIGINAL ROTARY VALVE
MINIATURE AIRCRAFT ENGINE**

**NOW
ONLY
18.95**
AT YOUR FAVORITE DEALERS

IMPROVED over 14 years of continuous production. Proven an outstanding engine for contest or pleasure flying. Thousands of thrill-packed hours built into each "Cyclone".

ONE PRICE for this superior miniature engine. Your rotary valve "Cyke" is complete when you buy it. No extras to purchase to bring this engine up to maximum power. Buy "Cyclone" and be sure.

Manufactured by

SUPER-CYCLONE, INC.

GRAND CENTRAL AIR TERMINAL

1117 AIRWAY • GLENDALE 1, CALIF.

SUPER-CYCLONE — BIGGEST NAME IN LITTLE ENGINES



Keep Ahead....

TRAIN FOR AN

AVIATION CAREER

IN SUNNY SOUTHERN CALIFORNIA

AERONAUTICAL ENGINEERING MASTER AVIATION MECHANICS

(NO FLYING INVOLVED)

**NEW STUDENTS MAY ENTER IMMEDIATELY—BOARD AND ROOM NOW AVAILABLE
MAXIMUM TRAINING IN MINIMUM TIME**

Using modern training equipment, including jets, the courses are intensive, highly concentrated, complete and C. A. A. approved, with all non-essentials eliminated. Leadership training is stressed... Upon graduation you will be an *aviation expert and fully qualified to hold a remunerative and responsible position in the aircraft industry, forge ahead steadily and add more dollars to your pay check...* Established in 1929 "Cal-Aero" is one of the oldest, largest and most distinguished aeronautical schools in the world. It is located on its own famous airport... Grand Central Air Terminal, in the Los Angeles-Hollywood Metropolitan area, in Glendale—the heart of Southern California's giant

aircraft industry, "Cal-Aero" has over 7,000 successful civilian graduates in addition to more than 26,000 pilots and 7,500 aviation mechanics trained for U.S. Army and Navy Air Forces.

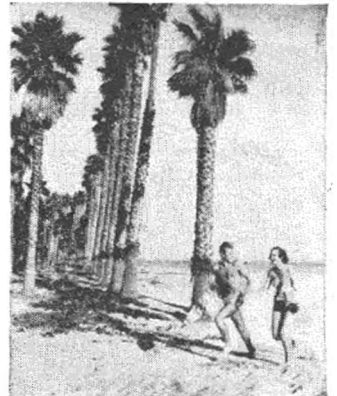

**WE HAVE THE EXPERIENCE—
THERE IS NO SUBSTITUTE FOR IT**
Cal-Aero has solved the housing problem! Board, room and transportation is now available right here on Grand Central Air Terminal.
APPROVED FOR VETERANS
TRAIN IN
SUNNY SOUTHERN CALIFORNIA



MAIL TODAY—DON'T DELAY

BE WISE...PROTECT YOUR FUTURE

EST. 1929

CAL - AERO
TECHNICAL INSTITUTE



GRAND CENTRAL AIR TERMINAL
GLENDALÉ 1, (Los Angeles County) CALIFORNIA

CAL-AERO TECHNICAL INSTITUTE N-4
GRAND CENTRAL AIR TERMINAL, GLENDALÉ 1, CALIFORNIA

Send full information and catalog, free and without obligation, on courses checked below:

CAREER COURSES

AERONAUTICAL ENGINEERING

MASTER AVIATION MECHANICS

HOME STUDY COURSES

HOME STUDY—AERONAUTICAL DRAFTING

HOME STUDY—AIRCRAFT BLUEPRINT READING

HOME STUDY—STRESS ANALYSIS AND DESIGN

Name _____

Address _____

City _____ Zone _____

State _____ Birth date _____

Check one: Veteran Non-Veteran

ESTABLISHED 1931
SAN FRANCISCO CHICAGO NEW YORK

A generation of mail order business guarantees our service and your satisfaction. Our business depends on pleasing you. Your mail order business should be sent to us because:

LARGEST HOBBY MAIL ORDER FIRM IN AMERICA 1948

FREE—FREE with GAS MOTORS:

Coil, Condenser, Wrench, Hi-Tension & Ignition Wire, Coil No. 1 or 2, Propeller, Presto Starter, 50 Page Engine Manual, Complete Instructions, Plug Gauge Set, Battery Box, Switch, Etc., 16 Items Worth \$6.00 See Item No. 8.

with PLANES:
Sponge wheels, Pro model knife, 150 pg. Construction manual

- 14-Day Money Back guarantee on unused purchases.
- Unused purchases exchangeable.
- No postage or packing charges—we insure safe delivery.
- 24 hour service—no waiting. New York, Chicago and San Francisco addresses to serve you faster.
- Most complete gas model stock in America.
- Competent understanding of your modeling problems.
- No "minimum" orders. Any order is welcome.
- FREE Coil, condenser, 3-way wrench, hi-tension and ignition wire, coil holder, correct propeller, Presto Starter, 50 page Engine Manual, Complete Instructions, plug gauge set, battery box, switch, mounting bolts, wiring lugs, log book, #70 oil, 24 page catalog. Membership in the Modelcrafters of America with most gas motors listed. \$6.00 extra value at no extra cost.
- FREE sponge wheels, "Pro" model knife and 150 page book on Gas Model Plane Construction with every plane. \$2.00 extra value at no extra cost.
- FREE membership in "Modelcrafters of America," the club that keeps you up to date on gas modeling and SAVES YOU MONEY ON YOUR PURCHASES.
- FREE illustrated 24 page catalog with every order.
- We don't carry everything—ONLY THE BEST. If it's advertised, we can supply it.



Our own four story building to serve you in N. Y. C. Drop in for a visit.

MOTOR ACCESSORIES

Battery Box (all sizes)	\$.46
Megaw Plastic (pen or med.)	.40
Aero Coil (Featherweight)	2.50
Aero Coil, Quality	3.00
Smith Competitor Coil	1.95
Arden Coil	2.50
Winston Coil	2.00
Wilco Coil	1.95
Regular Coil	1.50
Metal Condenser	.45
Paper Condenser	.20
Ignition Wire (6 feet)	.25
Glow Plug	.85
Spark Plugs (all sizes)	.50
Arden Booster Jack	1.25
Switch	.30
Vitamite Flight Battery	2.35
Vitamite Booster Batt.	5.00
Power-plus	
Flight Battery	2.75
Booster Battery	3.50
House Charger	4.45
Auto Charger	1.95
Arden Flight Timer	1.85
Austin Flight Timer	1.50
Comet Flight Timer	1.00
Hillcrest Flight Timer	1.25
Universal Needle Valve	.50
3-Way Plug Wrench	.15
Neoprene Tubing (per ft.)	.30
Spirit Starter	5.00
Alum. Engine Mounts .30 & .50	
Flo-Torque Props	
8" to 14" .35, 15"	.50
16" to 18"	.75
Hi-Ball 9" to 14"	.50
Hi-Pitch Props: 8", 10", 45c;	
12", 13", 60c; 14", 65c.	
Topping 3 Blade Plastic	
Props	1.50
Sponge Rubber Wheels 2",	
40c; 2 1/2", 50c; 3 1/2",	
60c.	
Teaser Balloon Wheels:	
2 1/2", 20c; 2 3/4", \$1.00;	
3", \$1.25; 3 1/2", \$1.50;	
4 1/2", \$1.75.	
Spray Gun	\$1.25
Modelers Plane	.75
Flywheels A or B	1.00
C	1.50
Univ. Running Stand	1.25
Wright Test Block \$4.95 and 9.50	
Jem Pump Can	.75
Presto Disc Starter	.25
Wood Stripper	.25
Austin Tank	.50
Froom Gas Tank	1.00
Mazco Tank	1.25

FREE FLIGHT CONTROL-LINE PLANES

(FREE: See Item 9 above) For "A" & "B" Motors

Coronet 46"	\$2.50
Buccaneer 48"	3.50
Bee 48"	1.95
Brooklyn Dodger 56"	3.95
Pacer B 53"	3.95
Tapper 41"	3.50
Roamer 45"	2.95
Zambie 44"	2.50
Rocketeer 40"	2.95
Playboy Jr. 55"	3.25
Buccaneer B Spl. 54"	3.95
Amer. Ace 54"	3.95
Banshee Std. 50"	2.00
Wanderer 54"	3.50
Bay Ridge Mike 49"	2.00
Zipper 54"	5.95
Runt 44"	2.50
Air Foller 44"	3.95
Zipper "A" 32"	1.95
Pixie "A" 42"	1.95
Musketeer 54"	3.50
Amer. Ace 36"	1.50
Stanzel Interceptor 51"	2.98
Skyrocket 36"	2.95
Ranger 46"	2.50
Comet Interceptor 42"	3.95
Musketeer 42"	2.50
Brigadier 58"	2.95
Yogi 42"	3.95
Jersey Javelin 48"	3.95
Larkey 50"	3.50
Mercury Jr. 50"	3.95
Gold News 50"	3.95
Powerhouse 56"	4.95
Powerhouse 41"	3.95
Silvaire 43"	3.00
Megaw Piper Cub 53"	4.50
Ensign 50"	4.50
Crusader 48"	7.50
Humdinger 52"	3.95

For "C" Motors

Piper Super Cruiser 84"	\$10.95
Pacer "C" 60"	4.95
Buccaneer Std. 66"	5.95
Buccaneer C Spl. 72"	6.95
Super Buccaneer 90"	9.95
Mercury 72"	5.50
Playboy Sr. 70"	6.00
Stinson Heliant 78"	17.50
Musketeer Std. 72"	4.95
Cavalier 60"	5.95
Wag 60"	4.95
Vagabond 74"	5.50
Custom Cavalier 108"	17.50
Saiplane 78"	8.95
Speargun Sr. 60"	3.95
Skybug 66"	6.95
Super Quaker 76"	7.00
Skybuggy Biplane 42"	5.95
Powerhouse 62"	5.95

No premiums on price-fixed items

Bantam Spl. 17" A-B	2.75
Shark G-3 30" B-C	4.95
Sharkadet 30" B-C	3.95
Wildfire 23" B-C	2.50
RoOKIE Trainer 36" B-C	3.95

U-CONTROL ACCESSORIES

100' Stranded Speed Wire	\$ 1.95
140' Stainless Steel Wire, 50c; 100', 40c.	
Perrycraft Swivel Tank	2.00
Jem Control handle-pistol grip	2.50
Wood "Gun" Control Handle & Reel	2.85
Metal Control Handles	1.25
Wood Control Reel 5 1/2" diam.	1.25
U-Reely Control	2.50
U-Reely Remote	12.50
Sullivan Accessory Kit	1.25
Snafu Accessory Kit	1.00
Thum-it Handle	1.95
Elev. Control-It	1.95

FLOAT KITS

Type 20	
40" to 50" span planes	\$1.00
Type 30	
up to 80" span planes	1.50
Type 40	
over 80" span planes	2.50

GAS BOOKS

Gas Modelers Guide	\$1.00
Gas Engine Handbook	1.00
Model Plane Constructor	1.00
Control-Liners	1.00
Model Airplane Design Building & Flying Model Airplanes	3.75
Model Gas Engines	2.50
Model Aircraft Handbook Gas Models & Engines	3.00
Model Motor Manual	3.00
Air Age, 21 Models	2.00

RACE CARS

McCoy Proto, Invader or Hot Rod	\$42.50
Dashing	45.00
Reult	24.95

Also Complete Line of Parts and Accessories.

GAS BOATS

Dolphin 21" A-B	\$ 6.50
Commando 20" A-B	5.95
Sea Bird 24" B-C	4.95
Markin 26" C	7.50
Reult 26" B-C	15.00
O-Gee 28" C	5.95
O-Gee Built-up hull	10.95
Hardware for Sea Bird	2.95
Hardware for O-Gee	4.95

Also Complete Line of Boat Accessories.

SPECIAL Complete Flying Outfit

- Fully guaranteed Class B Model Gas engine, ready to run.
- Skystreak model U-control plane kit (A. J. Walker patents. Precarved fuselage and wings. Easy to build and fly.)
- Wilco coil.
- Condenser.
- Hi-tension wire.
- Insulated ignition wire.
- U-control wire.
- Rubber wheels.
- Farmed landing gear.
- Correct propeller.
- Cement.
- Control handle.
- Ignition switch.
- Battery box.
- Spark Plug wrench.
- Champion Spark plug.
- Bell crank.
- Mounting bolts and nuts.
- Wiring lugs.
- Speed Indicator.
- Presto engine starter.
- Plug gauge set.
- Motor cover.
- 50 page book: Gas Engine Theory.
- 150 page Control-liner book.
- Insignia.
- Flight log.
- Complete engine instructions.
- Complete plans for building plane.
- "Pro" all-metal knife.
- No. 70 oil.
- Coil holder.
- Bubble canopy.
- Sandpaper.

35. Membership in Modelcrafters of America. 35 DIFFERENT ITEMS \$20.00 Retail Value for only \$10.00 Your choice of Genie or Juddo Engines \$12.50 Your Choice of Ohlson 19 or Thor Engines

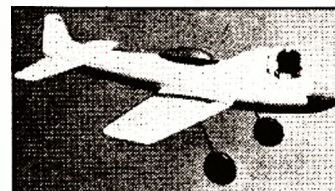

GAS MODELERS! FOUR BOOKS \$1.00 YOU MUST HAVE Each Postpaid

GAS MODELERS GUIDE..... 1.00
An encyclopedia for the gas model enthusiast. How to use your engine in planes, boats and cars. 32 cuts, pictures and diagrams. 15 chapters on: Free-flight planes, Control-line Planes, Cars, Model Boats, Radio Control, Winning Contests, Dictionary.

MODEL GAS ENGINE HANDBOOK..... 1.00
150 pages, 15 chapters, 83 pictures, cuts and diagrams. Theory and practice. Specifications. Blueprints of 2 engines. Directory of Model Engine Manufacturers. Dictionary.

GAS MODEL PLANE CONSTRUCTION..... 1.00
How to construct gas model planes, both free-flight and Control-line. Chapters on: Gas Model Structures, Tools, Basic Glue Joints, Fuselages, Wings, Tails, Accessories, Covering, Doping, Finishing and Repairs.

CONTROL LINERS—How to Build & Fly Them..... 1.00
History, theory and practice of building and flying control-line models. 160 pictures & Diagrams. Chapters on: Methods of Flying, Types of Models, Basic Design, Structural Design, Flight Controls, Engine Controls, Power Plant, Final Assembly.

2 MARVELOUS CATALOGS We have two fine, large catalogs for you. One is FREE, the other costs you 10c (stamp or coin). Hundreds of illustrations, thousands of items. Special articles on selecting your plane and engine, flying, trouble shooting, etc. Gas—Rubber—Solids—Planes—Cars—Accessories. SEND FOR YOURS TODAY!!

If it's Advertised we can supply it!

HOW TO ORDER Send remittance in full (we prepay package and insure) or send \$1 and we ship collect C.O.D. same day for balance. Address your order to us at your nearest branch.

Dept. MC-48 156 West 22 St., New York 11, New York
Dept. MC-48 55 E. Washington St. Chicago 2, Illinois
Dept. MC-48 Suite 230—742 Market St., San Francisco 2, California

AMERICA'S HOBBY CENTER, INC.

A GENERATION OF FAIR DEALING GUARANTEES YOUR SATISFACTION



America's Hobby Center is the country's LARGEST motor and gas model headquarters.



Read Free Offer on opposite page

ENGINES

• Arden .099	Cl. A	\$12.50
• Marvin	Cl. A	15.50
• Bantam	Cl. A	18.50
• Bullet	Cl. B	12.75
• Cannon 300	Cl. B	19.75
• DeLong 30	Cl. B	19.50
• Forster 29	Cl. B	14.85
• Forster .305	Cl. C	14.85
• Hurricane	Cl. B	19.75
• Melcraft	Cl. B	18.50
• Rogers 29	Cl. B	15.75
• Torpedo	Cl. B	18.50
• Super Cyclone Dual	Cl. C	23.00
• Super Cyclone	Cl. C	22.00
• Cannon 358	Cl. C	21.50
• Ohlsson 60	Cl. C	11.95
• OK Super 60	Cl. C	18.00
• Rocket	Cl. C	22.50
• Vivell 35	Cl. C	18.00
• Vivell Twin	Cl. C	45.00
• K & B Torpedo 29	Cl. B	18.50
• K & B 24	Cl. B	16.50
• Mohawk Chief	Cl. B	8.95
• Pacemaker	Cl. C	24.95
• OK Super 29	Cl. B	16.50
• OK Twin	Cl. C	49.00
• Super Champion	Cl. C	17.50
• Atom	Cl. A	15.50
• Arden .099BB	Cl. A	15.50
• Arden .199	Cl. A	18.50
• Vivell 49	Cl. C	20.00
• Contestor	Cl. C	18.50
• Ken	Cl. C	25.00
• McCoy 60	Cl. C	35.00
• Hornel 60	Cl. C	22.75
• Wessen	Cl. B	20.00
• Hurlleman	Cl. C	20.00
• Madewell	Cl. C	12.50
• G. H. Q.	Cl. C	9.95
• Judco Kit	Cl. B	6.95
• McCoy 49	Cl. C	25.00
• McCoy 29	Cl. B	19.50
• Air-O Mighty Midget	Cl. C	25.50
• O.K. Bantam	Cl. A	16.50
• Phantom P-30	Cl. B	13.95
• Pierce "J"	Cl. B	9.95
• Hassad Sky Devil	Cl. C	37.50
• OK 60 Race	Cl. C	23.00
• Forster 99	Cl. C	24.75
• Genie 29	Cl. B	6.95
• Rogers Ram	Cl. B	9.95
• New Thor	Cl. B	9.95
• New Thor Kit	Cl. B	6.95
• Ohlsson 19	Cl. A	9.95
• Ohlsson 23	Cl. B	9.95

DIESELS

• Aero Diesel	Cl. B	\$16.50
• Mavo Diesel	Cl. A	21.50
• Drone Diesel	Cl. B	21.60
• Mite Diesel	Cl. A	18.95
• C I E Diesel	Cl. A	16.50
• Deezil	Cl. A	12.95
• Deezil Ball Brg.	Cl. A	17.95
• K & B Glo-Torp	Cl. B	14.95
• O.K. Hot-Head	Cl. B	12.50

AIR ENGINES

• CO		\$ 4.95
------	--	---------

GLO PLUG ENGINES

• Mighty Midget GP	Cl. C	\$14.75
• Sportsman Jr.	Cl. C	14.95
• Sportsman Sr.	Cl. C	16.95

JET ENGINES

• Dyna-Jet		\$24.50
• Dyna-jet Redhead		35.00
• Minijet		35.00

These Engines Set the Standard for Quality and Price!!

the New... THOR "B"

\$9.95 KIT **\$6.95**

Fully machined, five minutes to assemble with a screwdriver

The Miracle Engine at a Miracle Price

Boy! Here is the engine you've always wanted. An engine that's been acclaimed the "easiest starting gas engine." It's the lightest weight class B engine — only 4 ounces complete, it's economical to run, long lasting and available at a reasonable price. Genie gives you everything! Compare the Genie 29 with any other Class B engine on the market at any price!

The Genie 29 has been developed by our staff — men with 15 and 20 years' experience — to give you a low-priced engine that incorporates the features of the highest priced engines available today plus additional features found in no other engine: No expense has been spared to make the Genie 29 an engine you can depend upon for fun in flying. High pressure Daehler-Jarvis die-casting; genuine silver contact points that eliminate pitting; Beryllium copper breaker point spring for smooth, constant operation; a transparent fuel tank and a gauge to estimate running time; chromium wearing surfaces; pressure lubrication of the piston and crankshaft; a Champion spark plug — all these features and many others make the Genie 29 the best buy at any price!

Genie 29

\$6.95

READY TO RUN NOT A KIT!

THE THOR GIVES YOU EVERYTHING YOU WANT IN YOUR ENGINE A REAL POWER PLANT!

- Ideal for free-flight and U-Control planes, bi-planes and midget cars.
- Complete fully illustrated instruction manual.
- Full 30 day guarantee against defective parts.
- Every part precision engineered to perfection.
- Lowest weight of all "B" engines without sacrifice of power.
- Streamlined for cooler operation and longer life.
- Automatic "dual" carburetor for quick "break-in."
- Easy to start, "a twist of the wrist." High compression ratio for instant starting. New PRESTO die starter eliminates prop "flipping."
- Steady and consistent running.
- New intake design for non-flooding and positive adjustment.
- "STEEL-IZED" piston, cylinder and bearing surfaces micro-precision fitted to .0001 .3636 and wear proof. Special oil grooves for longer life.
- Extra long crankshaft of polished-ground steel, scientifically balanced. 1" bearing surface with forced double lubrication for longer wear.
- Patented designed four-ported Beryllium "FLOATING" liner—never needs adjustment—can't slip in operation. Positive automatic spring action.
- Castings made of new "THOR" alloy. With more heat dissipation and wearing quality than any other engine.
- Uniflow piston.
- Integral all-metal tank.
- Invertible and runs in either direction.
- Replacement parts available and interchangeable.

POWER, DEPENDABILITY, LOW COST "EASY TO START"—"EASY TO RUN"

SPECIFICATIONS:
.29 cu. in. displ.
weight 4 1/4 ozs.
Class B.
AMA Rules

SPECIFICATIONS:
.29 cu. in. displ.
weight 4 ozs.
Class B.
AMA Rules

MORE THORS & GENIES HAVE BEEN SOLD IN 2 YEARS THAN ANY OTHER ENGINE!!

Precision engineered—Precision built

Buy with confidence at A.H.C. where Your interests come first!!

2 MARVELOUS CATALOGS

We have two fine, large catalogs for you. One is FREE, the other costs you 30¢ (stamp or coin). Hundreds of illustrations, thousands of items. Special articles on selecting your plane and engine, flying, trouble shooting, etc. Gays—Bunnies—Snails—Planes—Cars—Accessories. **SEND FOR YOURS TODAY!**

ENGINE CLASSES
NYC Modelers may attend our free Sat. Night Classes (8:30 A.M.)
FREE — Strobotac rotor readings of your favorite Engine.

HOW TO ORDER

Send remittance in full (we prepay package and insure) or send \$1 and we ship collect C.O.D. same day for balance. Address your order to us at your nearest branch.

Dept. MC-48 156 West 22nd St.
New York 11, New York

Dept. MC-48 55 E. Washington St.
Chicago 2, Illinois

Dept. MC-48 Suite 230—742 Market St.,
San Francisco 2, California

AMERICA'S HOBBY CENTER, INC.
A GENERATION OF FAIR DEALING GUARANTEES YOUR SATISFACTION

THERE'S A *long* AND *SHORT* TO THIS **NEW ARDEN *FIRST***

THE ARDEN GLOW PLUG—an engineering achievement that has clicked with modelers throughout the nation—is now available with both long and short threaded sections.

plus

a GLOW PLUG ADAPTER which permits their use with Class C engines having the larger conventional $\frac{3}{8}$ " diameter plug opening.

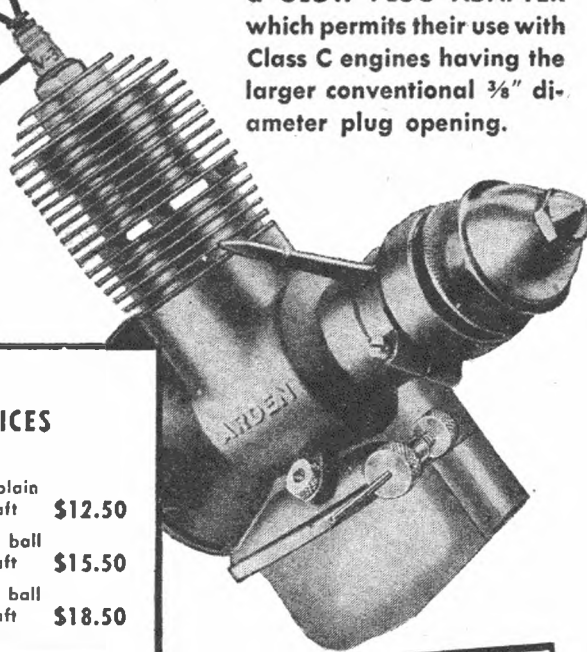
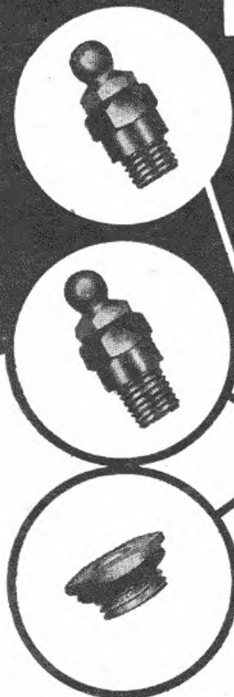

No increase in ARDEN ENGINE PRICES

Catalog No.

1-P-099	.099 engine with plain bearing crankshaft	\$12.50
1-B-099	.099 engine with ball bearing crankshaft	\$15.50
1-B-199	.199 engine with ball bearing crankshaft	\$18.50

ARDEN GLOW PLUG PRICES

For Arden and other engines with same diameter plug opening and same thickness of head—

No. E-8001 S (short), $\frac{1}{4}$ " x 32 T.P.I.
Length of threaded section $\frac{5}{32}$ " 85c ea.

For engines with same diameter plug opening but with thicker head than Arden—

No. 8020 L (long), $\frac{1}{4}$ " x 32 T.P.I.
Length of threaded section $\frac{7}{32}$ " 85c ea.

Glow Plug Adapter, for Class C engines with $\frac{3}{8}$ " x 24 T.P.I. plug opening, permitting use of long Arden Glow Plugs.

No. 8015, fabricated of aluminum with copper-asbestos gasket 25c ea.

Ask your supply dealer
or write us for information

MICRO-BILT INCORPORATED
DANBURY, CONNECTICUT



BY BILL WINTER

THIS BUSINESS of the timer turning his back on free flight hops of more than 10 min. under the new rules reminds us of the days when you could chase and time the model just as long as you could keep it in sight. Remember? At one of those Detroit Nationals, '36 we think it was, Benny "Sure-Shot" Shereshaw—who afterwards designed the *Bantam*—got off a corker of a flight. After a hot, dusty, safari, Benny, timer, and crew returned to the field with some quite remarkable flight time. Unfortunately the ship had been sitting by the judge's stand all the time; it had landed at the end of the field while the boys chased another model or a bird. Bill Berry of Philadelphia once watched those Brooklyn boys—and do we remember them—who could talk a man into timing the spots before his eyes, work out on a timer. So many of them still saw this model that the timer had no difficulty in seeing it too. Just then some kid walked up with the ship and said, "Hey, Joe, here's your model."

Maybe we should start a "Can You Top This?" contest. We'll try to talk the editor into wasting a free subscription on the best tall story teller of the month. In this screwball hobby of ours the best tall stories are the true ones. For instance, do you remember the time the papers carried the tale of the lost gassie that hit the mast of a ship 4 miles at sea? Mysterious, eh! That fellow had a good eye—or radar. Walt Schroder once flew some dawn patrol practice before a Sunday contest and his ship glided beautifully through an open bedroom window. Just as Walt huffed and puffed onto the scene, an irate gent reached out the window and crowned Walt with the pieces. Another day, at Creedmore, we saw two free fighters get so excited when their motor finally started that one of them hand-launched the big job, boosters and all. And it flew! Sorta . . . Say this could go on and on. So, if you want to get into the act, and win that grand prize of 12 issues of M. A. N. free for nothing, put your pet story on paper, glue it to the top of an expensive kit (contents intact) or any good motor and mail it to the man whose name you see at the top of this column. We're serious—about the story, that is!

Speaking of the hard-to-believe, the only fellow who resented our crack (two issues ago) about the Boston builder who put down his indoor models long enough to set a mark of 144 mph was Phil Pauley of South Plainfield, somewhere in Jersey. Phil likes the column but says that the "wild rumor" about the Bostonian wasn't fair. "Please give Kramer credit for the official record he made with his *Dooling*—with ignition!"

Digging through our file on records we find that a mark of 143.82 mph in Class VI Open had been made by William Viets, Springfield, Mass. The ship was of original design (name: *Snowflake*), *Dooling* 61. The fuselage was made of sugar pine, the wing built up with balsa sheet covering. Weight was 36 oz. Used Champion VR-2 sparkplug. Modelectric lightweight coil, four Burgess pencils, Aero Spark "racer" condenser. Fuel—gather 'round boys—was 2.5: 1 methanol-castor oil mixture, with no

(Turn to page 59)



WILLIWAW

This unusual configuration has advantages that few modelers appreciate until they try it

by BRUCE WENNERSTROM

THE WILLIWAW—so christened because it was built on Attu—is an experimental tailless model and is one of a series of similar designs built by the author during the past several years.

The model was designed to permit a maximum variety of setups to be used. Nose and tail plugs are interchangeable so that the ship may be flown as a tractor or pusher (or combination of both), while movable elevators permit easy trimming for changed C.G. position, incidence setting, etc. Swept forward wing designs have a number of advantages over the better known swept back type, especially for modelwork, most important of them being: control surfaces have greater moment arms than wings with an equal degree of sweepback; greater C.G. range (adjustments less critical); and the problem of tip stall is eliminated. Another big advantage is the fewer number of structural parts which permits the units used to be built much more ruggedly than conventional models.

The *Williwaw* is a stable model with an exceptionally flat glide, although the climb admittedly is nowhere near as spectacular as that of the purely contest type rubber job. The design is unusual, the construction strong and simple, and flight characteristics good.

FUSELAGE—The plans are half size and may easily be enlarged. The fuselage is constructed by means of the keel method. Simply pin the upper and lower keels down and build half the fuselage right on the plan. Note that the formers are not notched; instead the stringers are cemented to their perimeters. This permits a much smoother covering job, at the same time speeding construction. Also note that the grain is alternated at each station to give maximum strength. The wing mount is

1/16 x 1/4 balsa.

Cement the wing mount dowel securely in place. Before covering, sand the entire frame lightly to remove any flaws or roughness which might mar the smoothness of the covering job. Silkspan is the covering material. Use the heavy gas model grade for the fuselage in order to resist tears and punctures. Double cover the bottom. Cover as large an area as possible without getting wrinkles. Don't worry about pulling the tissue tight, just make sure it's wrinkle free; dope will tighten it. Five coats of clear dope are brushed on.

WING—The wing is built upside down. All ribs are 1/16" sheet balsa. If hardwood is used, cut lightening holes. Ribs and other sheet members should be cut out before starting construction. Pin the spar down and cement the ribs to it. When the cement is dry, glue the leading and trailing edges in place, the balsa tips last.

Cover the section from the leading edge back to the spar, and the center section with 1/32 sheet balsa. All ribs are cap stripped with 1/32 x 1/4 balsa. Sheeting the leading edge is best done by cementing the edge of the balsa sheet to the leading edge of the wing first, then when the cement has dried each rib and the spar is coated with cement and the sheet curved back and pinned in place until the structure has dried.

Study the details of the elevator construction carefully. Note that they are hinged in the same manner as the control surfaces on real planes, which considerably cuts drag and increases their effectiveness besides improving appearance.

Sand the entire structure lightly preparatory to covering it.

Wings are best covered by applying the Silkspan wet and
(Continued on page 41)

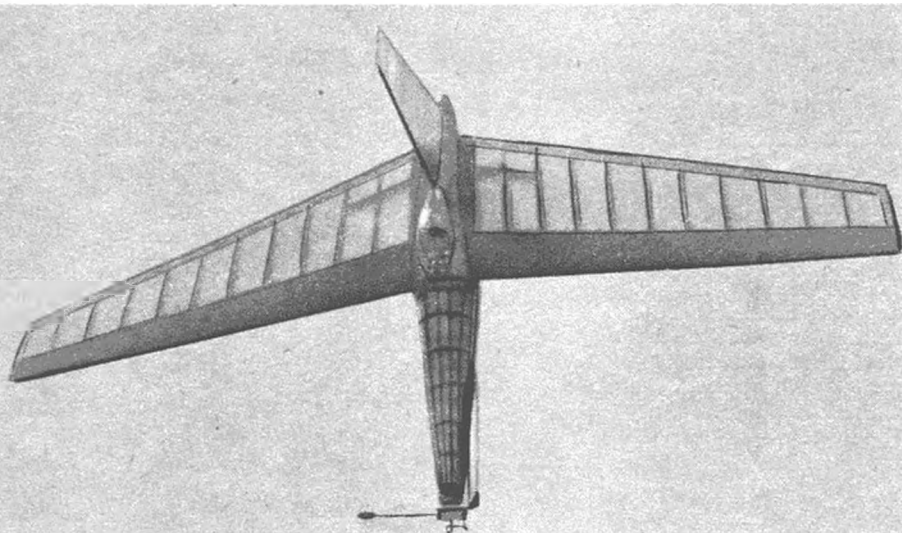

MODEL AIRPLANE NEWS • April, 1948

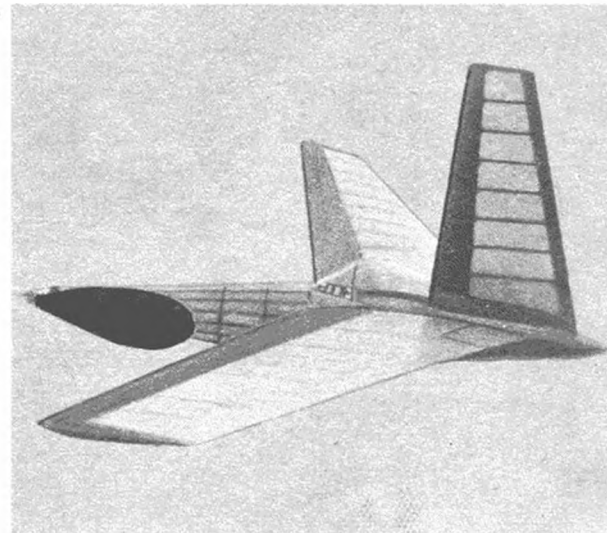

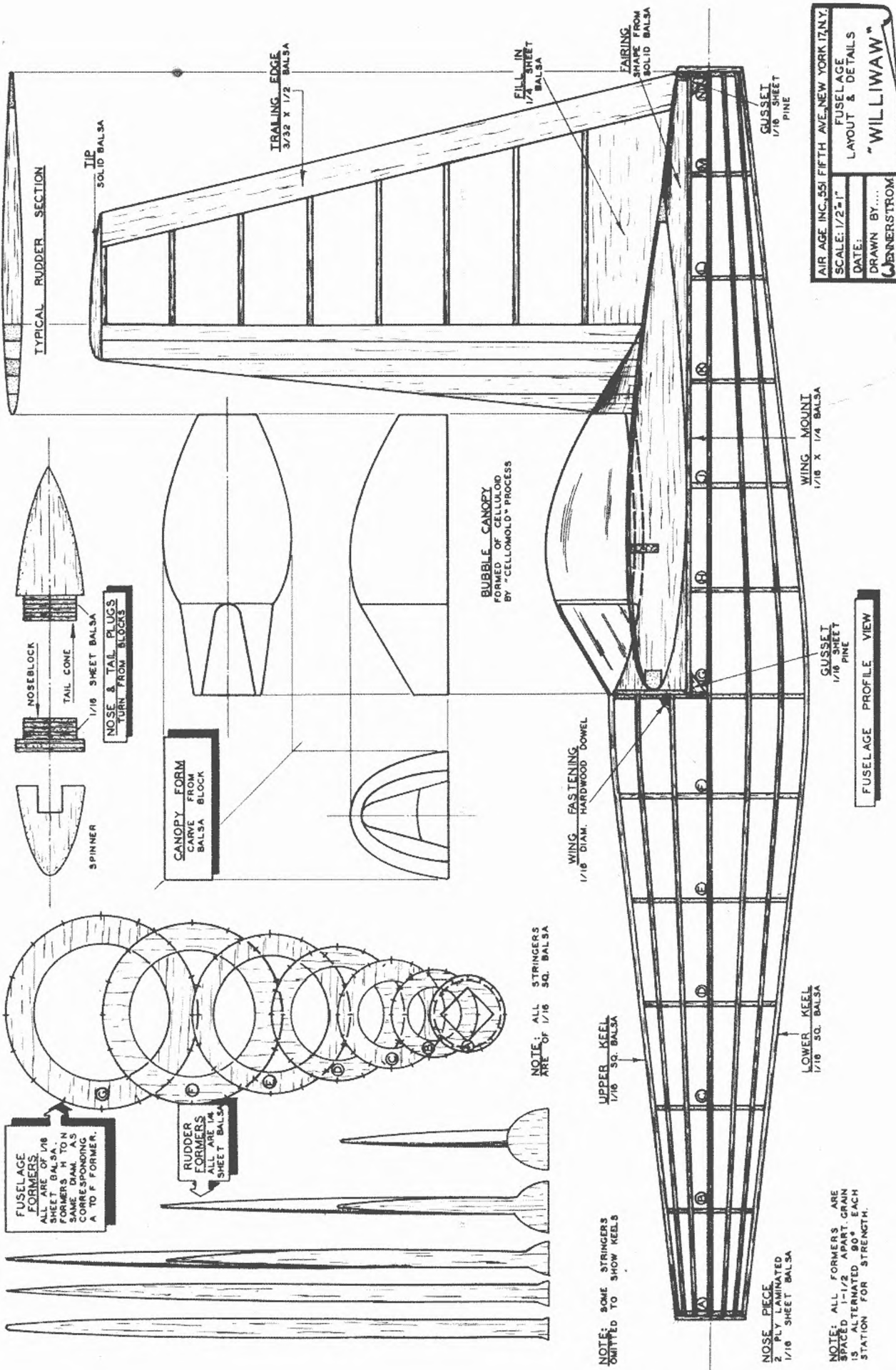

AIR AGE INC., 551 FIFTH AVE., NEW YORK 17, N.Y.	
SCALE: 1/2" = 1"	FUSELAGE LAYOUT & DETAILS
DATE:	DRAWN BY: JENNERSTROM
"WILLIWAH"	

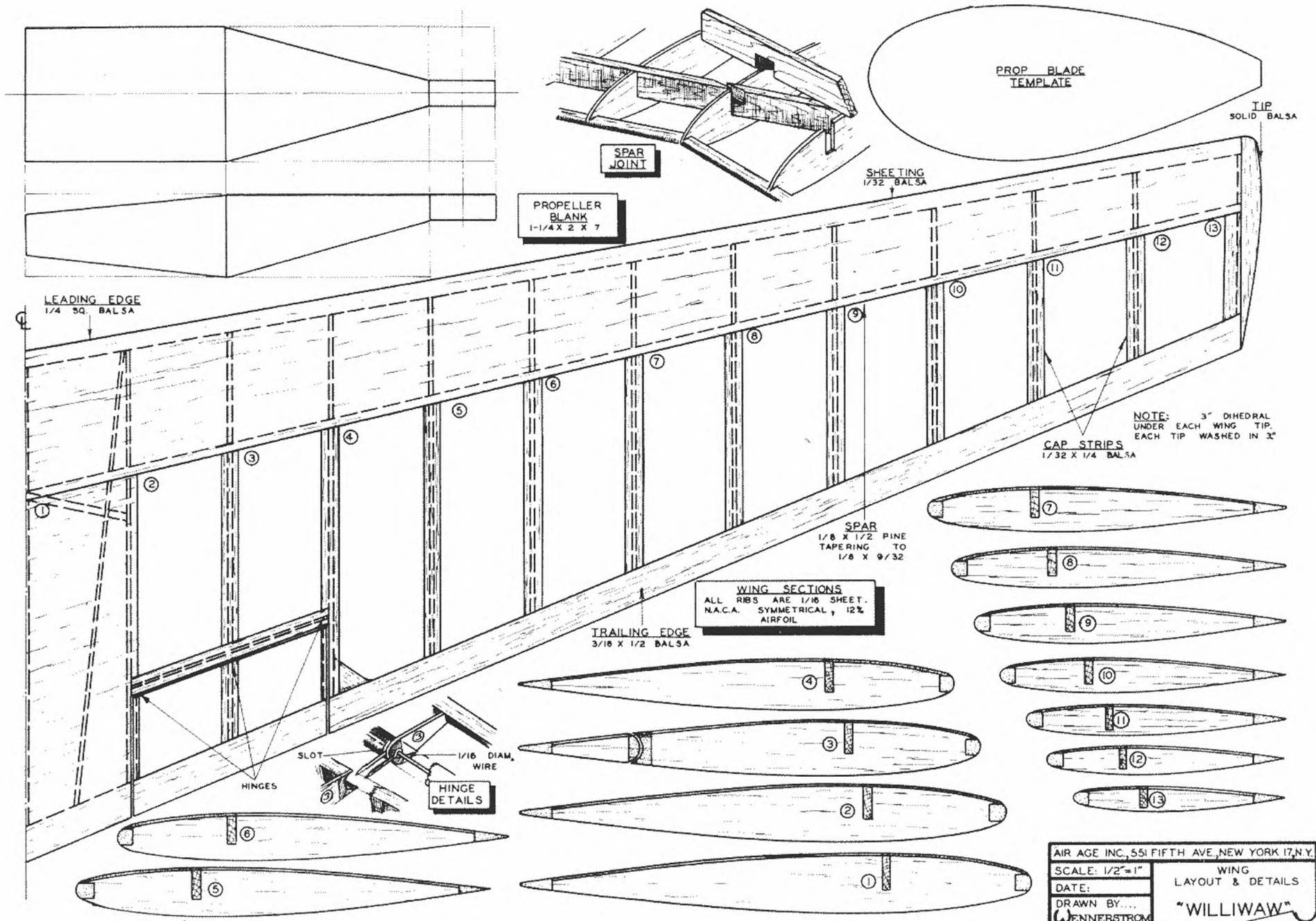

AIR AGE INC., 551 FIFTH AVE., NEW YORK 17, N.Y.
 SCALE: 1/2" = 1"
 DATE: _____
 DRAWN BY: WENNERSTROM
 WING LAYOUT & DETAILS
 "WILLIWAW"

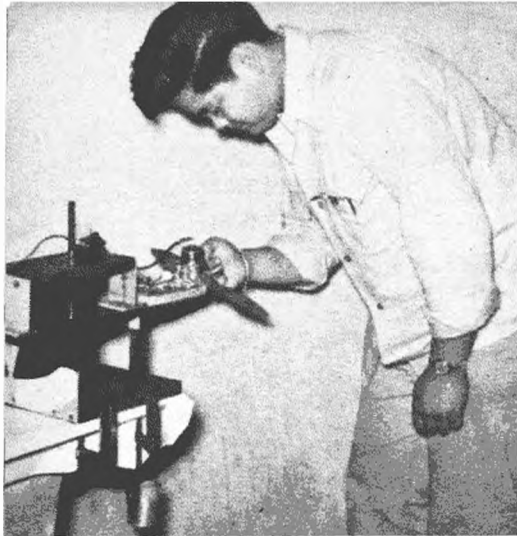

Ready to try a motor—lock pin in place

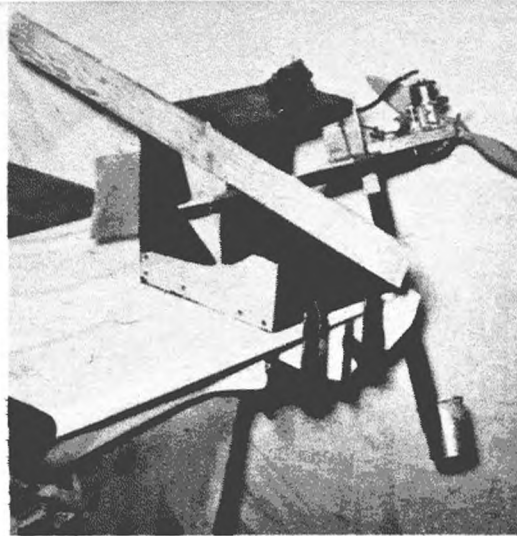

Calibration bar fastened to rear section

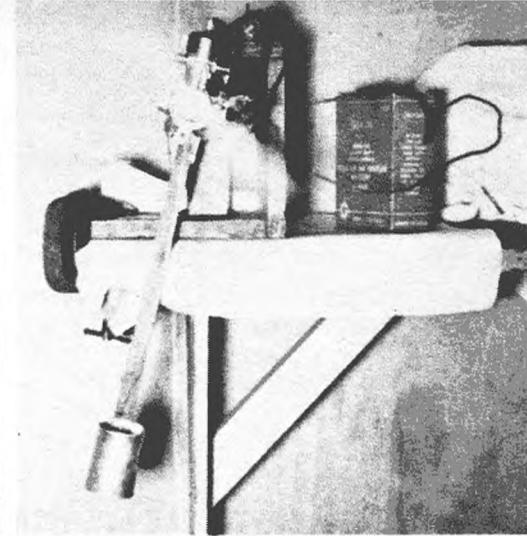

Motor running and ready for a test

Checking Horsepower

Build this torque stand and KNOW what power your engine produces
by FRED R. YOUNGREN

PRESENT day contest rules favor engines which develop the highest horsepower per cubic inch. A hot engine properly handled will naturally give a higher rate of climb and thus a better chance to win. Various ideas have already been used successfully to increase the power to displacement ratio.

Here's another way which has resulted in as much as a 50% increase in available horsepower. It is based on the fact that many model engines are not run at the speed at which they develop maximum horsepower. A *Super-Cyclone* which had been operated at 7200 rpm with an output of .4 hp before making the tests is now operated at 12,000 rpm with a power output of .6 hp (see Fig. 1). Similar results were had with other engines; some were found to respond to increased speed, other to slower speeds. Even engines of the same model had different power versus speed variations. This shows that no general conclusion may be reached, for each engine is unique. Only two devices are needed to run similar tests on your engines: a tachometer and a torque stand. The tachometer can be purchased for around \$2, and construction and operation of a torque stand is described below.

A four view drawing of the stand is shown in Fig. 2. The main frame is assembled from 3/4 in. lumber (we used plywood) and should be built rigidly to

resist vibration. If necessary, metal gussets can be nailed across the corners to increase rigidity. The torque scale is mounted on a piece of sheet metal formed as indicated in the drawing. Dope was found to be satisfactory for attaching the paper scale to the metal. The ignition coil is strapped to the frame with a rubberband and held between two small nails.

The next assembly to make is the swinging arm which consists of a wooden bearer with balance arm, pointer, and two tee sections attached to it. The two tee sections were obtained from an aircraft salvage yard; however a section of angle stock or even bent up 3/16 in. plate would serve just as well. The hardware is bolted to the swinging arm bearer and this whole unit is then screwed to the main frame. Be sure to make the attachment holes in the tee sections a little oversize, and allow enough clearance from the frame so that the arm can swing freely. Washers will further reduce the friction. A hole should be drilled through the top of the main frame, through the swinging arm bearer, and into the lock block to provide for insertion of the starting lock pin. This pin is used to block the swinging arm when starting an engine for a test run. The engines are bolted to wooden mounts which in turn are held to the swinging arm bearer by two bolts and wing nuts.

Now that the stand is built, it must be calibrated so the scale readings will be true readings. This is done by using the calibration bar (see Fig. 3). First, clamp the stand to a bench and check to see that the base rests level. Then with the starting lockpin removed, set the pointer to read zero. Mount your engine on the stand ready to run just as it would be during a test; then fasten the calibration

bar to the rear tee section as shown in Fig. 3 and check to see that bar and arm swing freely. Rotate the swinging arm until the pointer reads .5 and hold it in this position. Place a string-suspended 1/2 lb. weight on the bar so that the horizontal distance from the weight string to the axis of the swinging arm is exactly 12 in. with the pointer set at the .5 reading. Add lead shot to the balance can until the pointer holds this reading when released. By tapping the swinging arm it is possible to get more accurate settings. The can should now be sealed to prevent loss of the shot; wide scotch tape works nicely but be sure to remove a few shot to allow for the weight of the tape. The calibration bar may now be removed and the stand is ready to operate.

To find output or brake hp of an engine, two things need to be known: the torque and the engine speed. Therefore you will need some type of tachometer. We found that the vibrating wire Vibra-Tac was well suited to our needs; a Strobotac would be perfect, but even a revolution counter and watch will do. The best systems of course are those which absorb no power from the engine such as the Strobotac or Vibratac.

To make a run, block the swinging arm with the lock pin and start the engine. When engine is warmed up, advance the spark and adjust needle valve until engine is running steadily at top speed. Now remove the lock pin and take a reading of both torque and rpm at as close to the same time as possible. By referring to the graph of hp plotted in terms of torque and rpm you can determine the hp developed on this run. After making several runs with different sizes of props (thus vary-

(Turn to page 64)

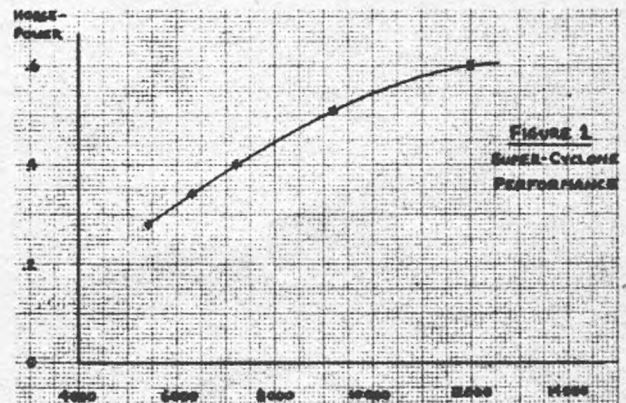
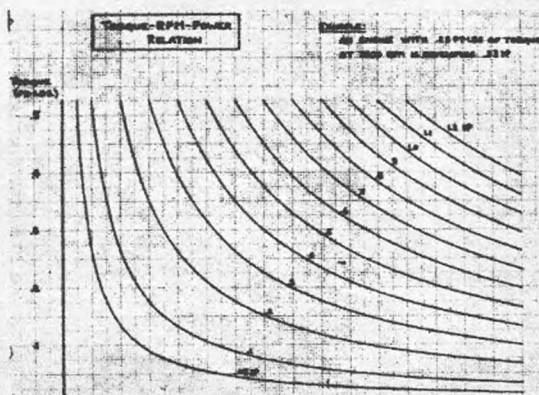

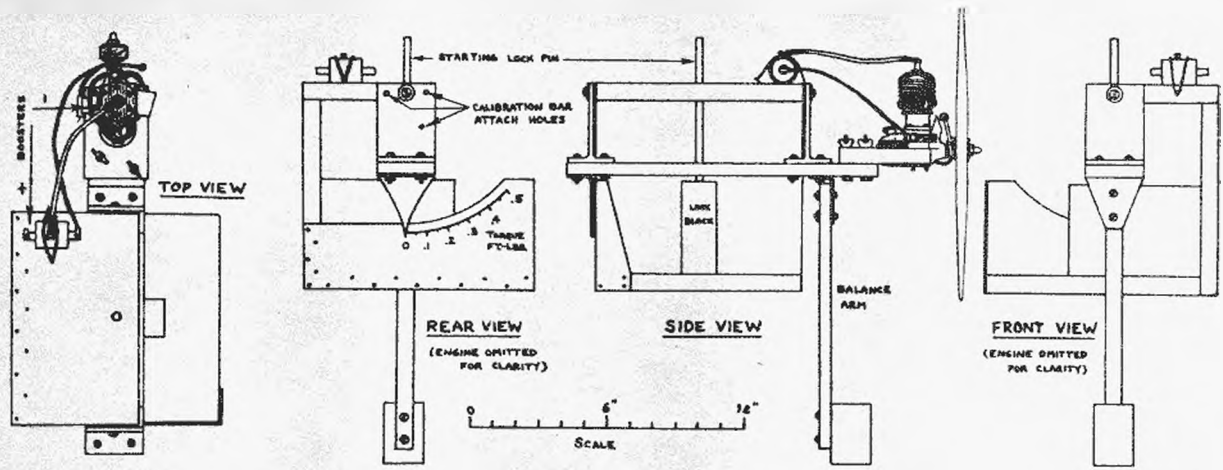
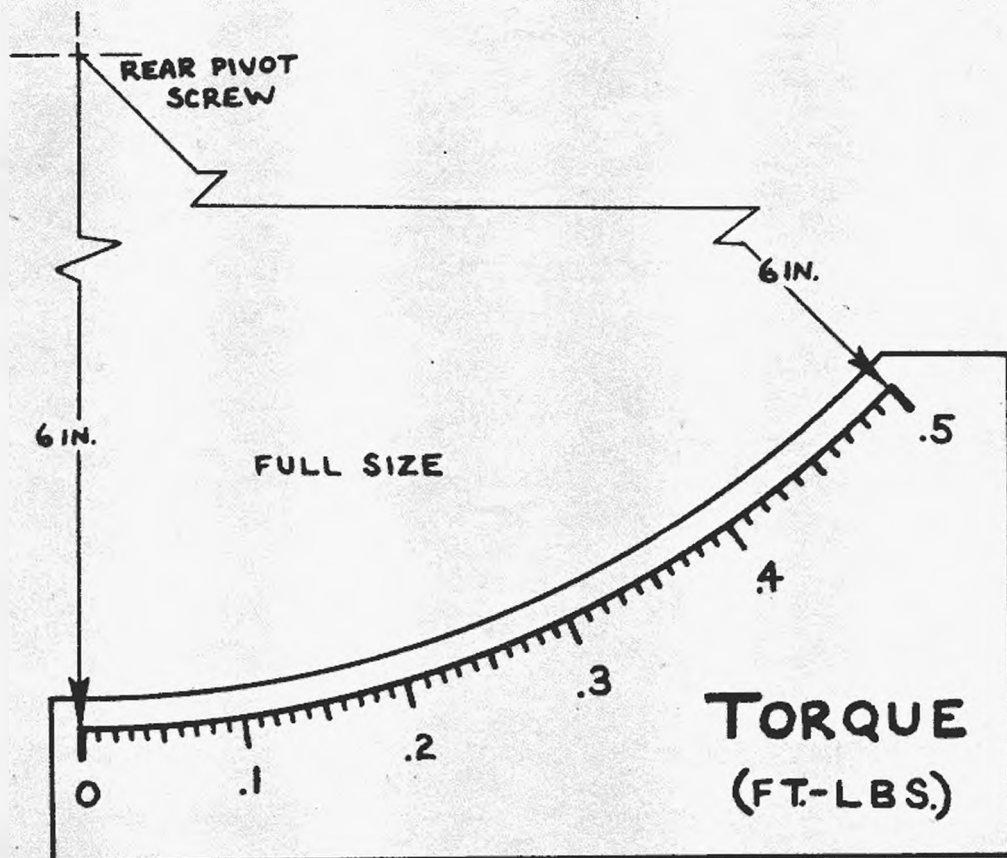
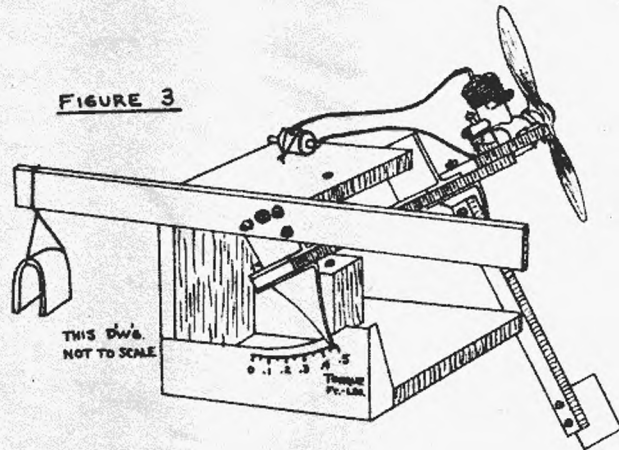
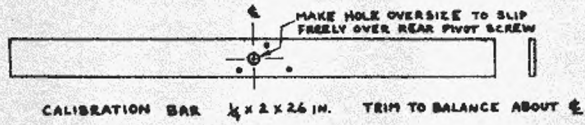
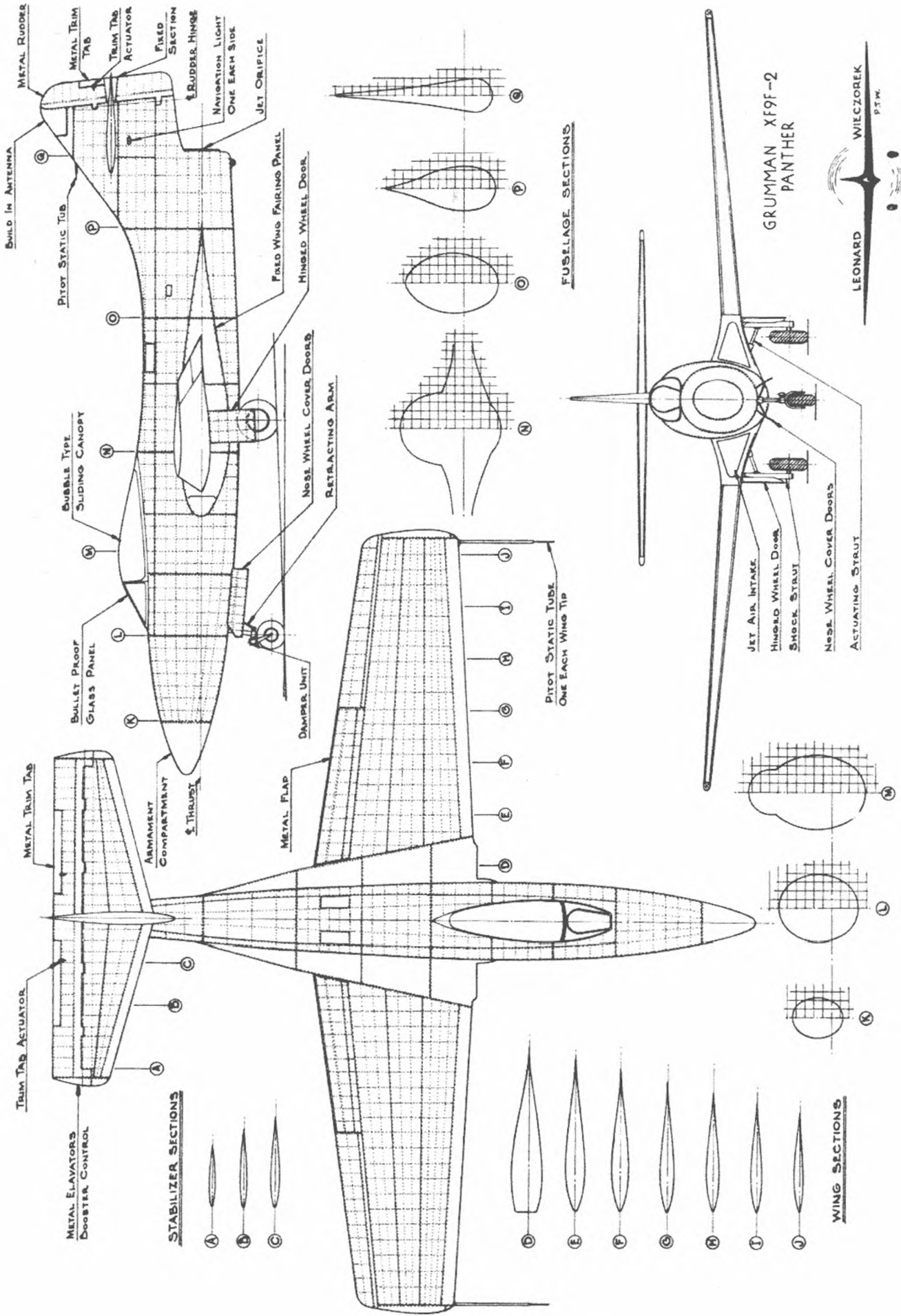

Fig. 2 Details of torque stand. It should be built to size shown for use with full size scale below





GRUMMAN XF9F-2
PANTHER



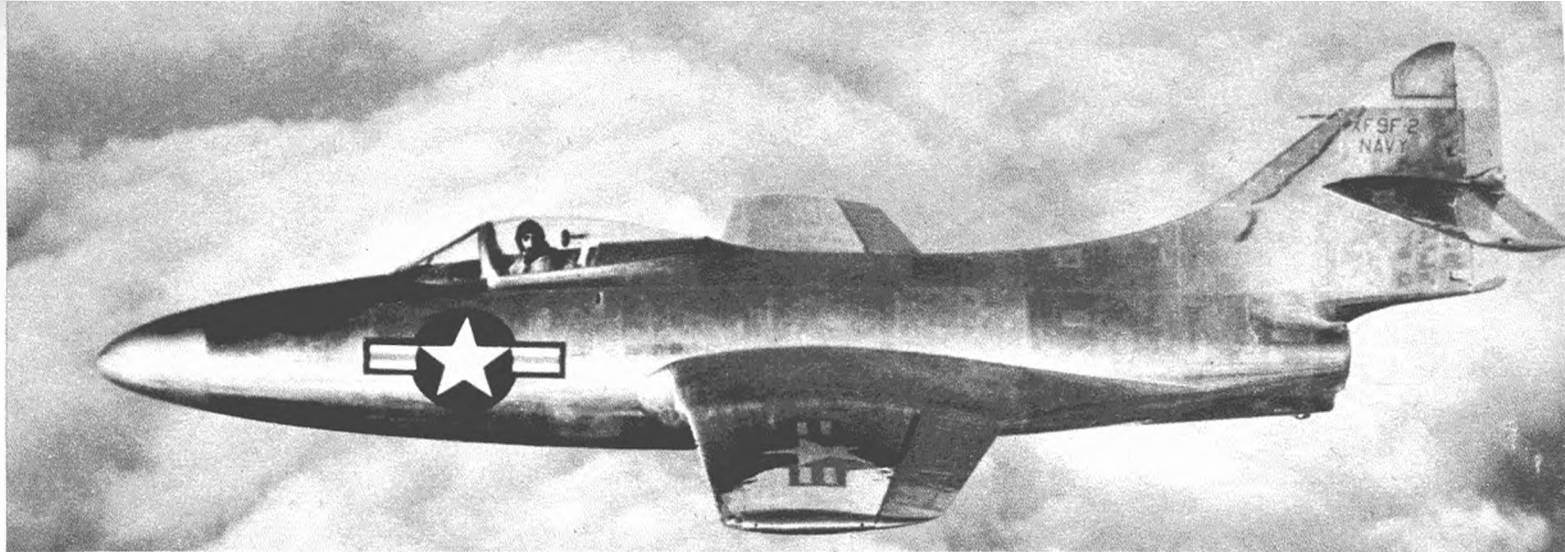

GRUMMAN PANTHER

PLANE ON THE COVER STORY

by ROBERT McLARREN

THE Panther—stubby, powerful jet fighter—is proof that Grumman is still “king of the carriers” in the single-seat fighter department. Not since 1932, when Grumman turned out its first fighter, has the Navy’s fighting branch been without a Grumman fighter model in production and aboard its aircraft carriers. And the new Panther will carry that unbroken tradition forward for another 3-5 years.

How has Grumman maintained this “corner” on the market? By (1) designing superior carrier fighter planes; (2) proving the ability to produce them rapidly and in the desired quantities; and (3) doing the job more economically than the competition.

Jet propulsion posed a challenge to Grumman engineers, after a decade of leadership in propeller-driven fighter design. With an unmatched war production record 1971 F4F Wildcat fighters; 12,272 F6F Hellcat fighters; 556 F7F Tigercat fighters; and more than 1200 F8F Bearcat fighters (the latter currently in production) the firm achieved honors and awards and a string of titles (“world’s largest output in a single month”, “largest production of a single type in a single plant”, etc.) all attesting to the productivity of the group. The only small question mark was: “Will Grumman clear the turbojet hurdle and continue its leadership?”

Months went by and still no word concerning a Grumman design project for a jet-propelled fighter. With F8F Bearcat fighters continuing to pour from the plant, the word grew that the firm was “sticking to” the propeller-driven fighter until it outgrew its usefulness (which will not be for several more years with Navy schedules calling for F8F production through 1949). Finally, early last December the mysterious Grumman jet-fighter was unveiled and engineers knew the reason for the long secret.

The firm was not content merely to produce another jet fighter (McDonnell, Vought and North American all had already gone out into the lead in the carrier jet fighter class). It wanted a superior jet fighter, not just faster or with longer range, but one that solved the Navy’s basic problems: (1) short takeoff—and fast waveoff; (2) mass productivity; and (3) economy of production.

The company assembled its top design team for the project. At the head of the list was of course Leroy Grumman himself, an able designer, a former Navy pilot and engineer and an astute guiding hand in the integration of the project into the overall problem of the company. Next in line was William T. Schwendler, vice-president of engineering, in administrative charge. For the initial design job there was Dick Hutton, assistant chief design engineer and Robert Hall, assistant chief experimental engineer. Hall is most widely known for his fabulous “Hall Racer” of the early ‘thirties with the “Buck Rogers” butterfly wing, neatly panted landing gear and sharp, sweeping tail. In immediate charge of the detail engineering of the project was Gordon Israel, project engineer. Israel shared National Air Race honors for the success of Ben O. Howard, whose “Pete”, “Mike”, “Ike” and “Mr. Mulligan” were products of Gordy Israel’s technical skill. On the Navy side was Marine Corps Major Ross Mickey, F9F project engineer in the Bureau of Aeronautics, and Lt. Comdr. W. J. Patterson, who handled the engine project.

This top-rung technical team first attacked the basic problem of the jet fighter for carrier use; slow acceleration. The power of a turbojet engine is a function of the airspeed of the plane in which it is mounted. For example, at low forward speed the jet fighter develops low power because it is a “momentum” machine rather than a “power” machine as is

(Turn to page 57)

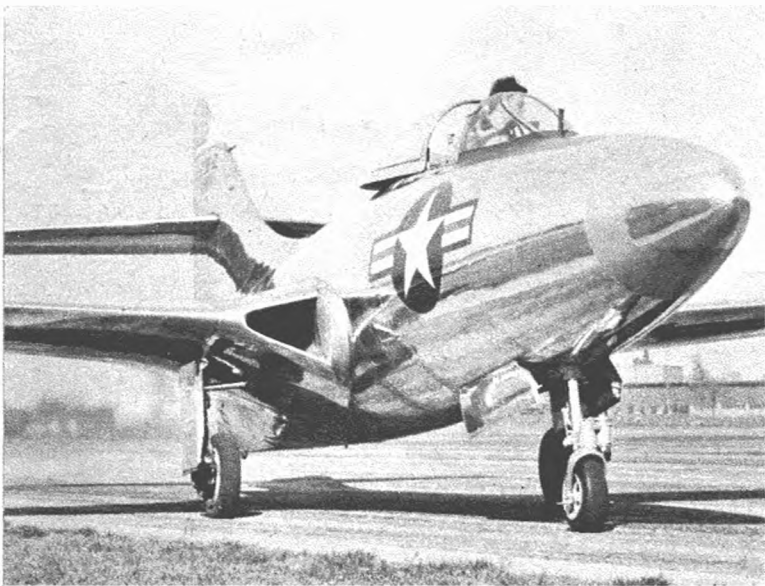
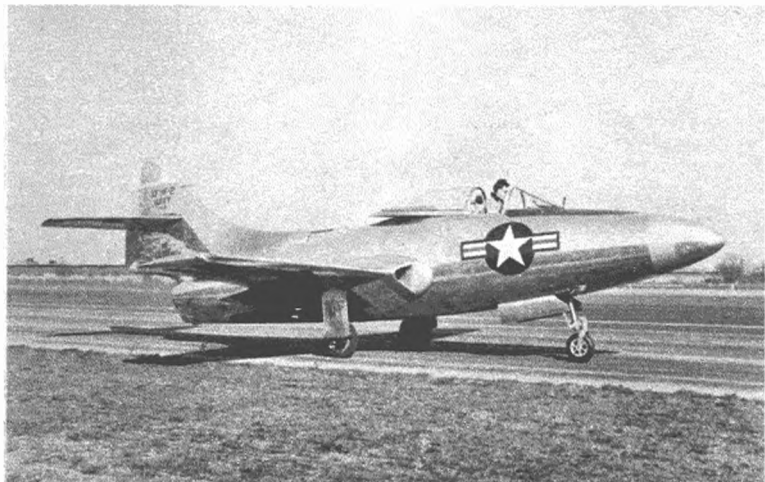

"SKIPPER"

CLASS "A" DIESEL MODEL

WING SPAN -- 30"
LENGTH -- 23-1/2"

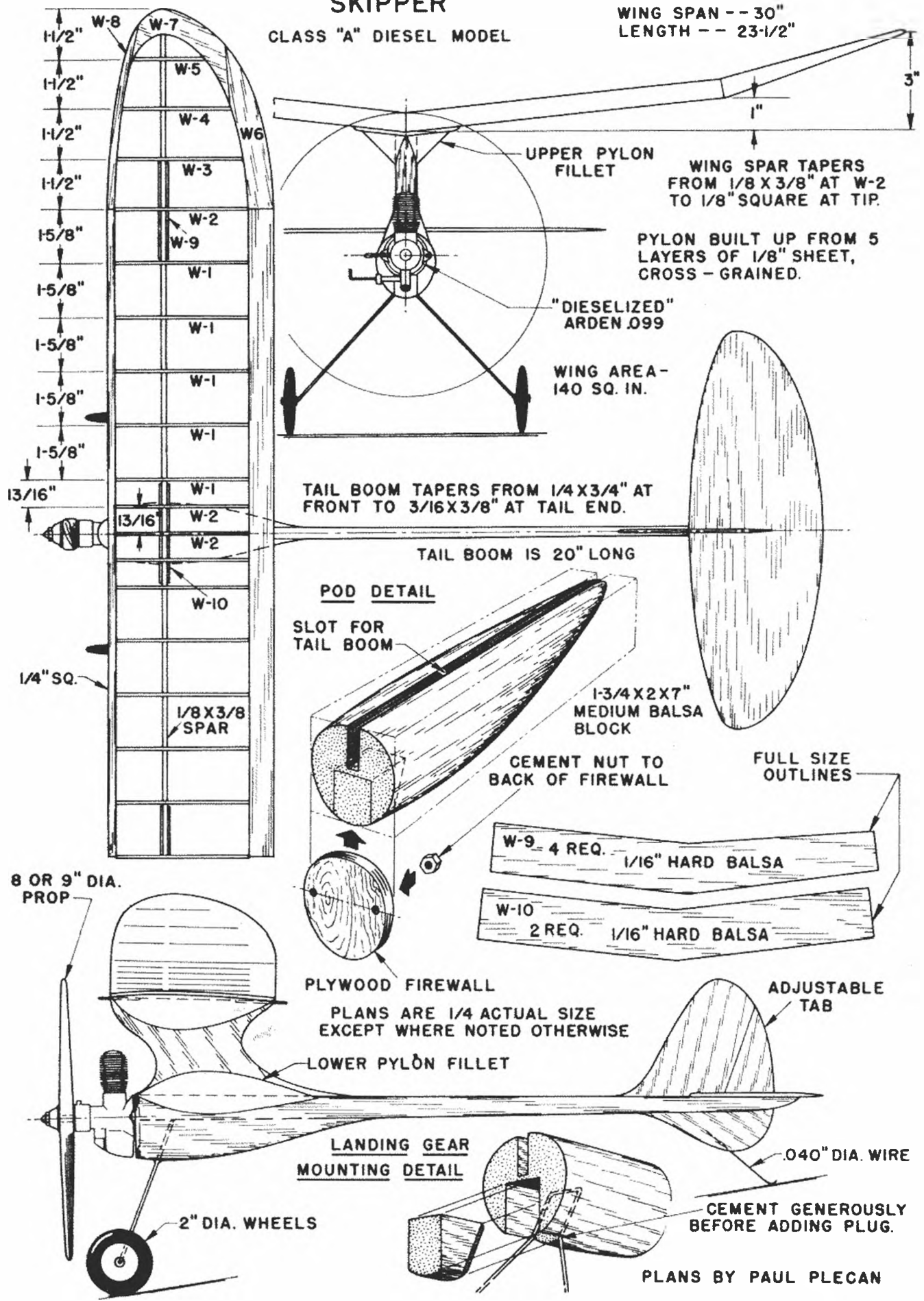

SKIPPER

by PAUL PLECAN

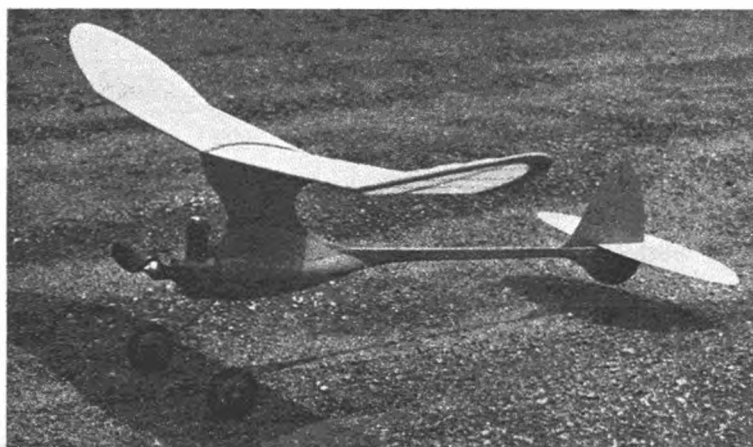
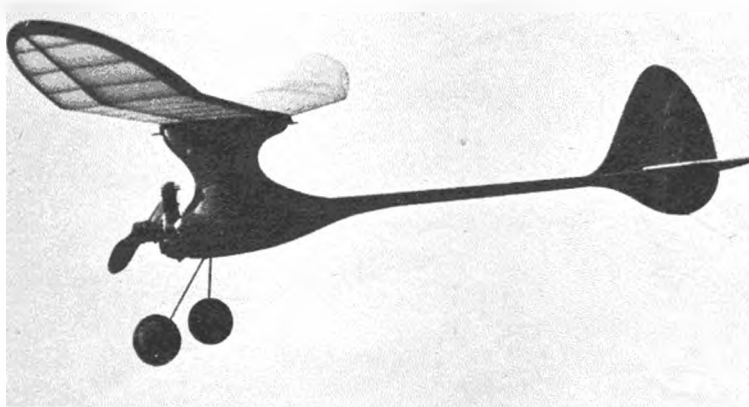
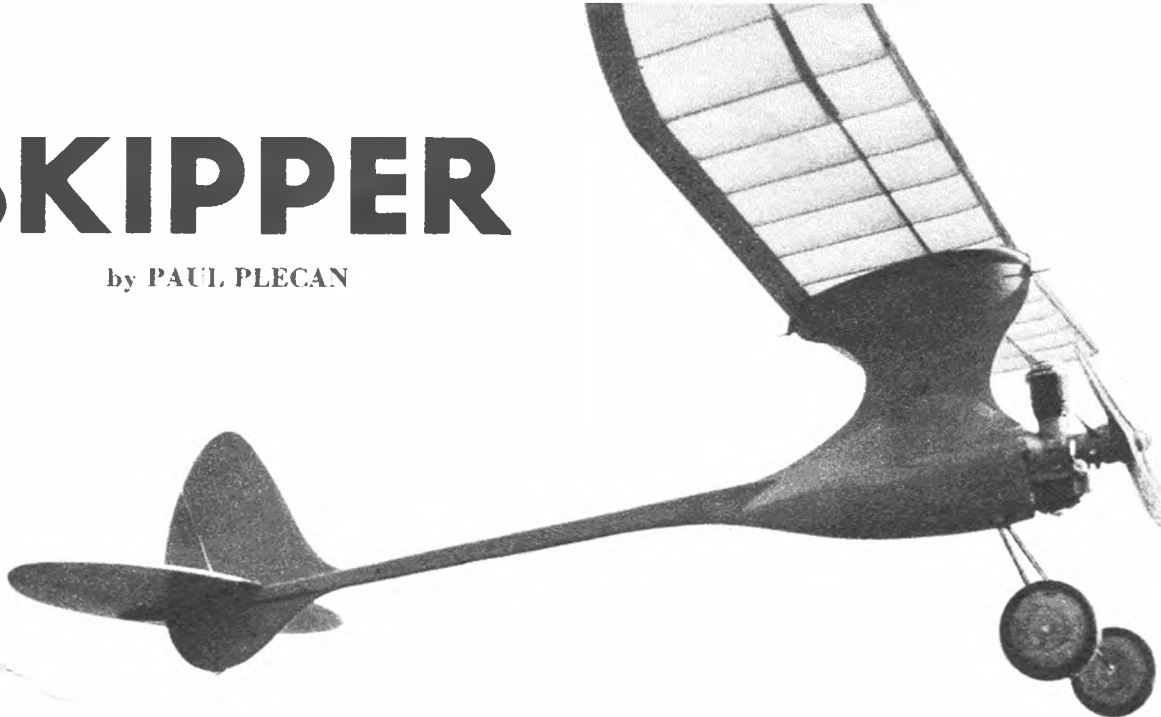

HERE'S a model that literally "flies off the workbench." About 12 hours of work is all that is needed to get *Skipper* airborne. Designed for any .099 engine, this 30" job will really go places due to its slick, simple design. Conforming with A.M.A. regulations, *Skipper* is a real threat in any contest if given half a chance. Tested with every conceivable type of adjustment, the plans show the happy medium arrived at after numerous flights with different sized wings and tail areas. The dieselized *Arden* engine used in the original model has behaved perfectly, considering the author's brief experience with ignition-less engines. With the dieselized *Arden*, or with a *Mite*, weight will have to be added to bring the model up to weight rule for contest work. More about that later. Interested in building *Skipper*? Well, grab a razor blade and . . .

Cut out the necessary ribs from medium 1/16" balsa sheet. This should be no trouble at all, considering the full sized outlines given on the plans. All four panels can be built simultaneously, then joined after the cement is dry through the addition of dihedral braces W-9 and W-10. While waiting for the cement to dry, get a piece of 1/4 x 3/4 hard balsa. Taper it to 3/16x3/8 at one end, round the corners off with sandpaper, and there you have the completed tail boom. The pod is simplicity itself, so we won't gab about it too much. If a battery, coil and condenser contraption is desired, you'll have to modify it to your needs, maybe enlarging it to hold all these old-fashioned items. The method of mounting the landing gear is optional. As shown on the plans, the struts are set at a rakish angle, but if you are in a hurry, simply cement the gear to the rear of the firewall or nose bulkhead.

Now you can tackle the pylon. Five outlines are needed—make it any way you want, but laminate the different layers crossgrained, obtaining a pylon 5/8" thick. (Never thought of *carving* it from solid 5/8" stock!). Oh well, once it has been sanded, cement it in place on the pod. The simple sheet balsa tail surfaces will take no time at all to make, but don't forget to make some provision for a trim tab on the rudder. Several coats of clear dope on the rudder, stabilizer, pod and boom, and you're ready to slap things together. Just be sure the pylon, landing gear and tail surfaces line up while cementing said parts together. A wing platform of 1/8" sheet goes on top of the pylon, set at the same dihedral angle as the wing center (use dihedral brace W-10 for this).

The bristol board fillets add quite a bit of strength and are aerodynamically clean. (I've been plugging these fillets for years 'n years but have never seen anyone else use 'em—honest fellas, they're simple!) Since these diesel engines spray oil all over the land-

(Turn to page 66)

FULL SIZE OUTLINES

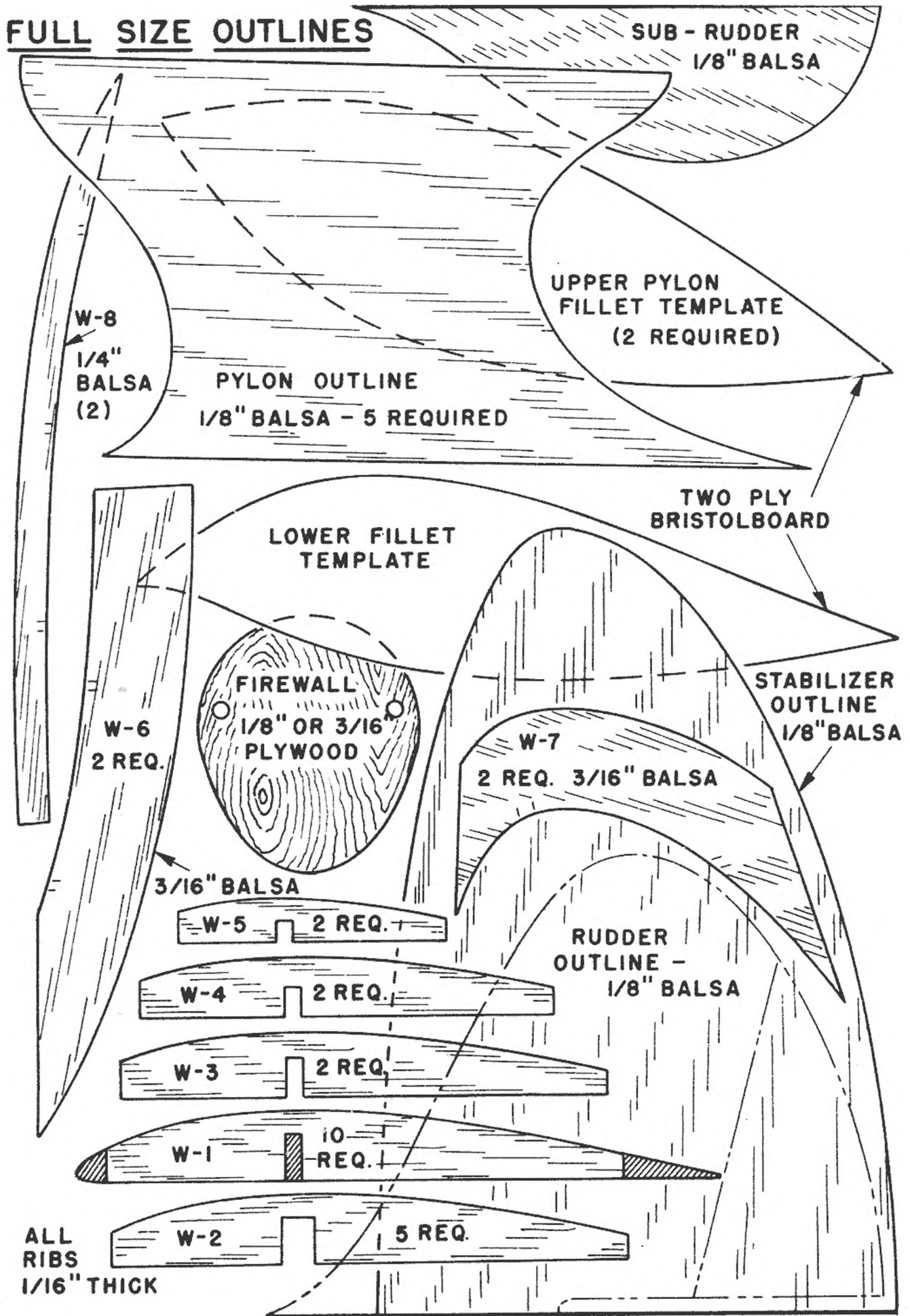

THE ANCIENT GLOW-PLUG

by NATHAN A. GORDON

The "glo" plug, as it is usually called nowadays, mystifies many users — study this story on how and why it works

THE HISTORY of the glo-plug and its variations is as old as the internal combustion engine. Around 1680, in Holland, the first internal combustion engine had its birth. It consisted of a cylinder with a movable top (piston); a charge of gun powder was placed inside the cylinder and ignited, or fired, by a flame held to a hole in the cylinder. The result, naturally, was an explosion which forced the top to move. Thus, simply, was the first recorded attempt at internal combustion engines made.

Further development involved piston, cylinder and a more practical combustible. The combustible was ignited by the flame of an outside burner which made connection through a hole or port; the opening made accessible at the proper moment by the piston's travel. Other methods of applying outside heat to aid ignition were found. Heat was applied via a hot bulb and hot plate which in turn transferred the heat inside the cylinder where it was used to ignite the fuel charge.

The first attempt at using compression ignition alone is generally credited to Rudolph Diesel. He tried such an engine with coal dust as a fuel. As an ignition aid for starting, an explosive powder was ignited and the results sent Mr. Diesel to the hospital seriously injured. He recovered, and in 1897 demonstrated a practical oil burning engine which today is called "Diesel" in his honor.

Most unique of the methods tried to facilitate ignition was the one used by a Minneapolis blacksmith. Way back in 1870 he arranged two hardwood blocks in such a manner that the friction created by rubbing them together developed sufficient heat to cause ignition.

From these beginnings the glo-plug evolved. The glo-plug is a metal holder for a fine coiled wire filament; this filament heats up and liberates the heat right where needed—inside the cylinder. To fully appreciate the significance of such a development, it may be of interest to know that glo-plugs are still in use in many large modern commercial engines. Their purpose is to aid ignition.

By use of the glo-plug, the engine becomes a form of compression ignition engine, but one distinctive feature of the spark ignition engine remains undisturbed. This is a pre-determined or fixed point of ignition. By its very design and operation the glo-plug is just that: a fixed ignition point.

The importance of this is understood when basic engineering facts pertaining to the internal combustion engine are known. While this article is limited, it is desirable to air some of these facts. In a diesel engine, the fuel and air do not mix and are not in contact with one another prior to meeting in the combustion chamber. Ignition is effected by the very high temperature developed with high compression ratios. In a spark ignition engine, however, fuel and air are mixed by means of a carburetor. The fuel is (theoretically) atomized and dispersed throughout the firing chamber. Each droplet of fuel is surrounded by a supply of air sufficient to support combustion when ignition is effected. The fixed ignition point now becomes important because, with this thoroughly mixed charge, combustion of the whole mass is rapid and takes place within the limited time allowed for complete combustion. Remember that the time in which ignition and combustion take place is a matter of finely split seconds. A delay in combustion will result in poor operation and often cause "knock" to be severe and even destructive to the engine.

Now, by adding the necessary factors which together will give the best possible combustion, it is seen that the glo-plug, as the fixed ignition point, is the focal spot in the entire cycle. The pre-mixed fuel and air charge is delivered to the firing chamber and the glo-plug does its work. Discarding of the usual ignition system—with its contacts, coil, condenser, wires and the necessary connections with their many possible sources of failure and increased weight—gives an apparent large advantage to the glo-plug user. The advent

(Turn to page 53)

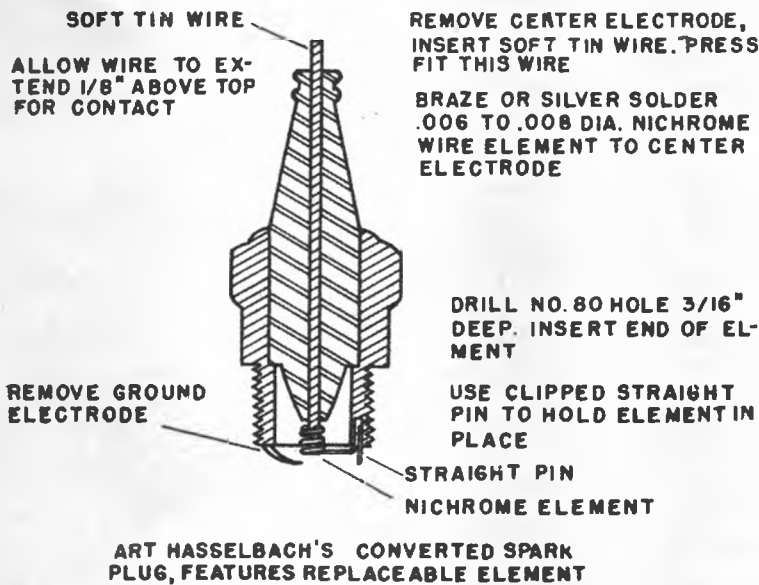
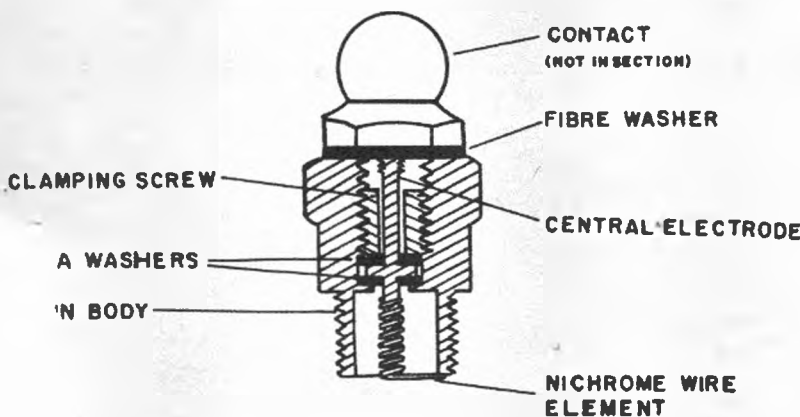

FIG. 1



ARDEN GLO-PLUG

FIG. 2

MODELING IN FLYING SCHOOLS

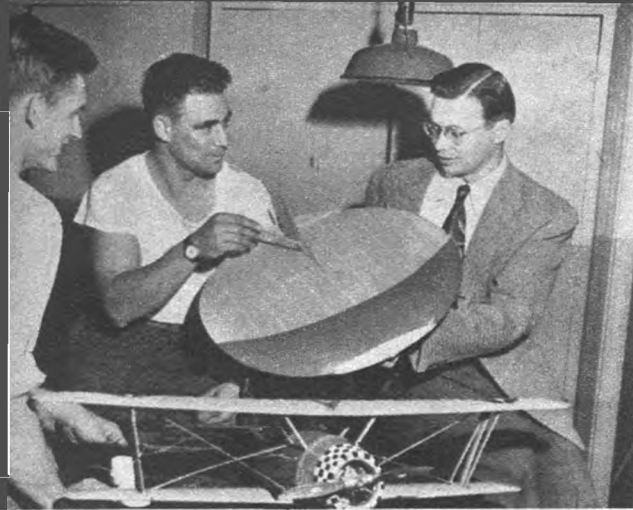

J. Shumway of Spartan, right, shows flying saucer to students

Flying schools not only tolerate modeling—they encourage it!

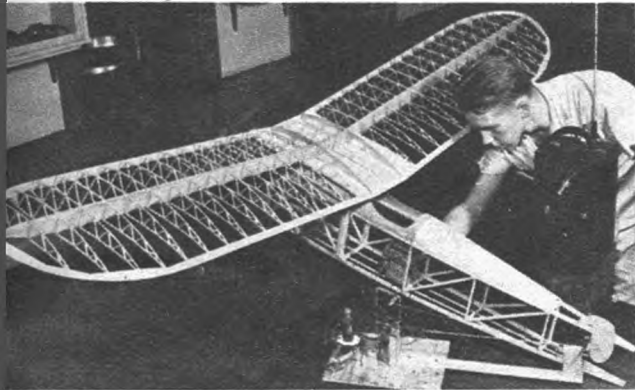

An ambitious experiment in radio control is underway at Parks

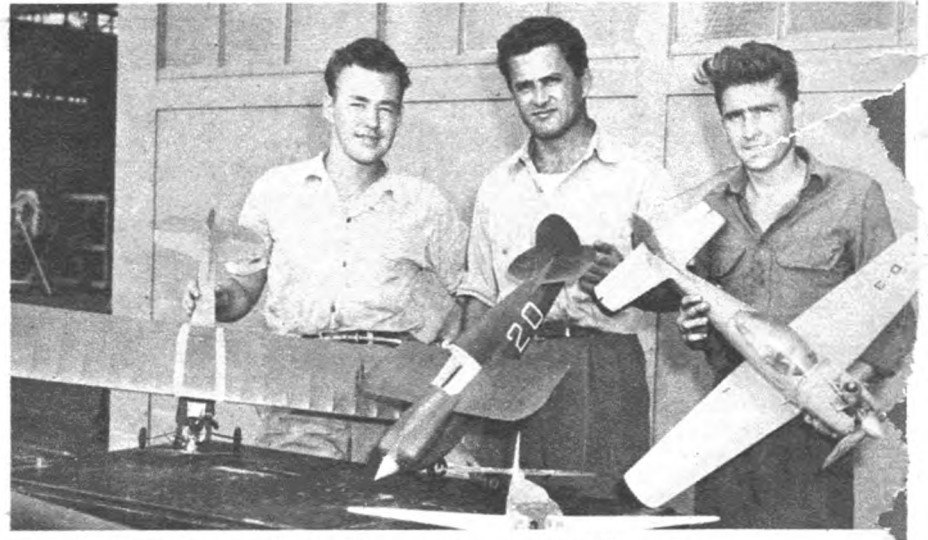

Embry-Riddle students Tyler, Palczewski and Stevens with control line models

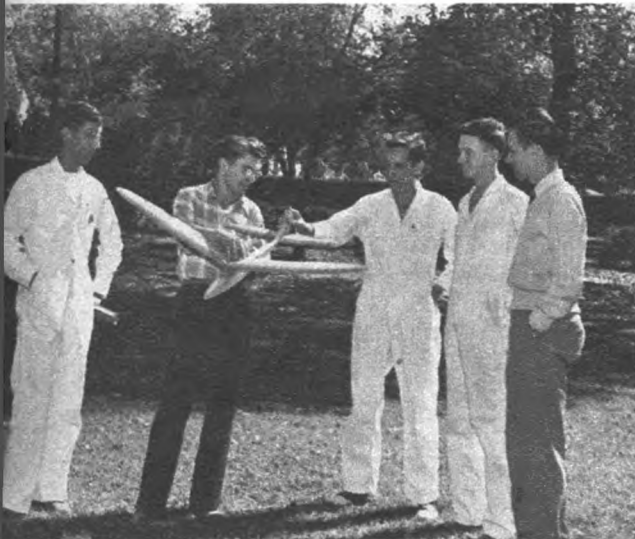

L. Schroeder shows plane ready for hop to other Parks students
O'Brien holds plane as Stephenson cranks starter at Northrop



Embry-Riddle instructor Betz, left, and group of fellow model builders

Group of student mechanics at Cal-Aero show planes to Stunt Champ Davey Stagle



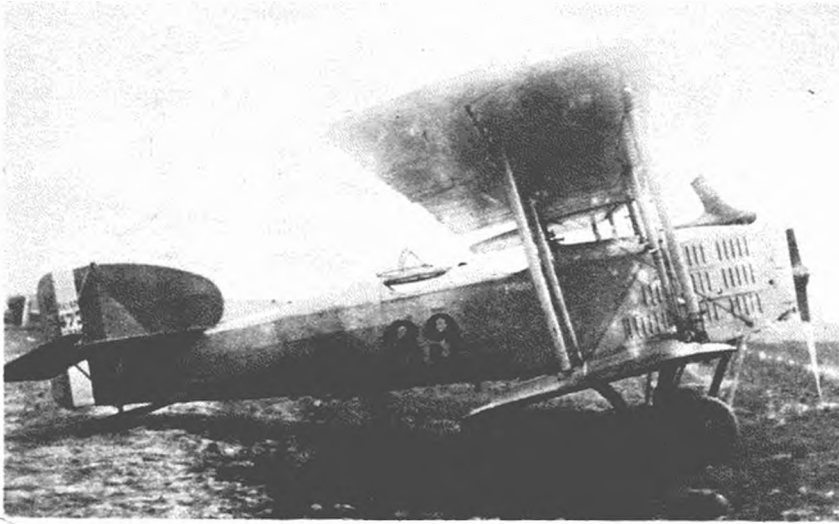

Back stagger is evident in this view of Breguet 14A.2 with Renault engine

WORLD WAR I

by ROBERT C. HARE

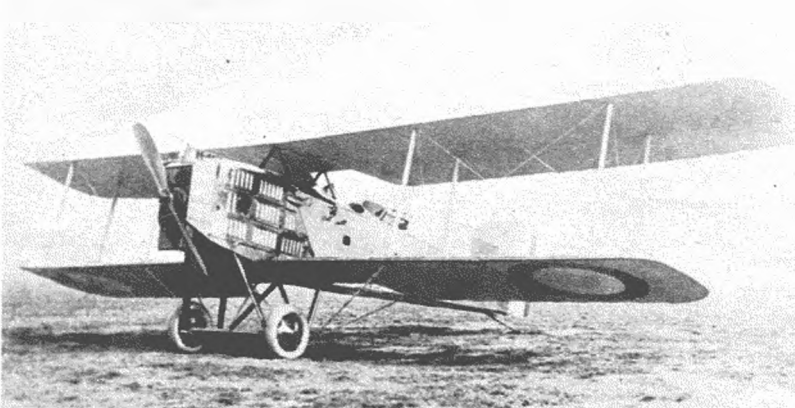

A 14A.2 with Fiat engine; note unbalanced ailerons, long radiator, no exhaust stack

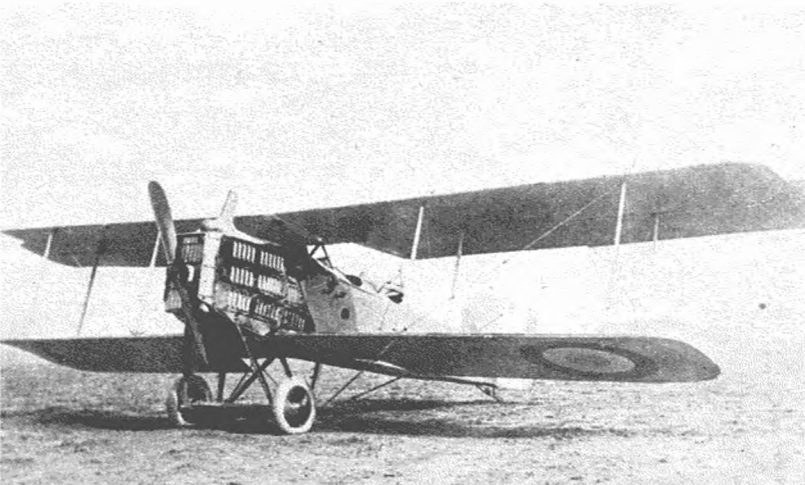

This model of 14A.2 had stack, balanced ailerons, short radiator, Renault 12Fcx motor

TOWARD the end of World War I, designers of all the warring nations had pretty well standardized on aircraft types in each category. Actually, by the end of 1917, the belligerent aircraft manufacturers found they could design aircraft objectively, that is, with a definite purpose in mind—with a high degree of success. Aircraft design was immeasurably more predictable than it had been two years earlier, and the old method of designing by guess and by gosh had just about seen its last day.

Standardization, of course, meant a great deal to the various air services. They were able to order in quantities, not only of aircraft but of engines, fuel and oil, instruments, accessories and raw and finished materials. Mechanics were better trained and more efficient with fewer types to work on. And the root of it all was the manufacturer's ability to build time-saving tools to speed production, with accuracy which permitted modifications of type and interchangeability of parts in the field without need for a factory rebuilding operation.

One of the best examples of a standardized aircraft type was the Breguet 14 series which was put out in two production versions: the 14A.2 (army cooperation) and 14B.2 (day bomber). Two field modifications were eventually used in limited quantities: the 14C.2 (two place pursuit) and the 14E.2 (trainer).

Breguet's versatile model 14 entered the picture late in 1916 as the 14B.2 and was a success from the start. It was capable of carrying 300 kilos. of bombs slung from carriers attached to each lower wing. While the 14B.2 was a good bomber, the French tended to rely on other types such as the Farman, Voisin and Caudron for this duty. The 14B.2 never was entirely retired from the scene as a bomber, but it faded out of the picture as the primary French bomber. When American squadrons arrived overseas they were given the 14B.2 with which to do their bombing. The aircraft performed notably with several squadrons as a day bomber, filling in until the famed Liberty DH-4, in production in America, reached the Front.

The French by no means did away with the basic model 14, however. Rather, they maintained a few 14B.2 units but diverted the bulk of production to a modified model, the 14A.2. Duties of this type were centered on the observation and photographing of various strategic areas, artillery spotting, and liaison. The types differed only in wing area, due principally to the use of balanced and non-balanced ailerons, the type of engine, and in the use of an automatic wing flap. The 14B.2, in order to get off the ground more quickly fully loaded, was fitted with full span automatic flaps; the 14A.2 had a conventional stiff wing. Specific differences will be discussed later in this article.

Louis Breguet

In order to fully appreciate the Breguet 14 series it would be well to become somewhat acquainted with the man behind the design, Louis Breguet. Like few of the true pioneers of aviation, he is still alive at this writing and takes an active part in the engineering affairs of his French company.

The name of Breguet is synonymous with the early days of French aviation. Prior to 1910 he carried out a number of experiments at Douai. It was Breguet who developed the first successful (though not practical) helicopter, mention of which can be found in the French aviation magazine *L'Aerophile* for September 1907. This helicopter lifted a total weight of 1100 lbs.

Breguet also experimented with more conventional aircraft. In September 1910 he flew his biplane with 5 persons aboard, a 150 lb. payload. Like Fokker, Breguet was a great believer in metal construction and even his

(Continued on page 52)

design forum

by CHARLES H. GRANT

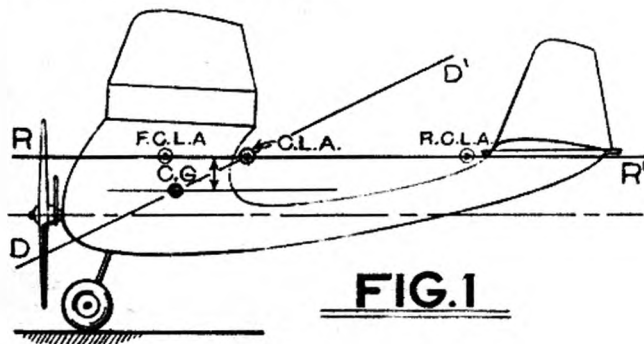

FIG. 1

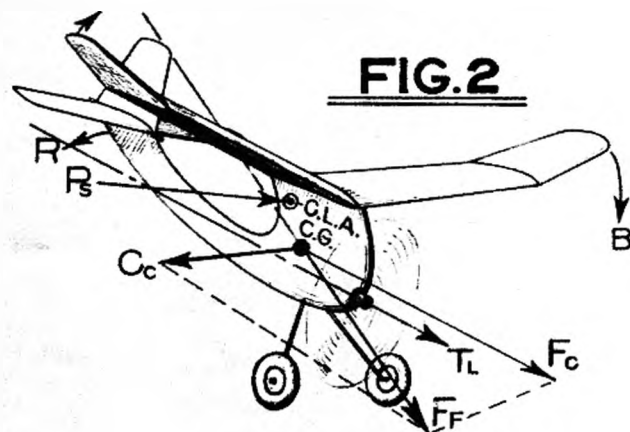

FIG. 2

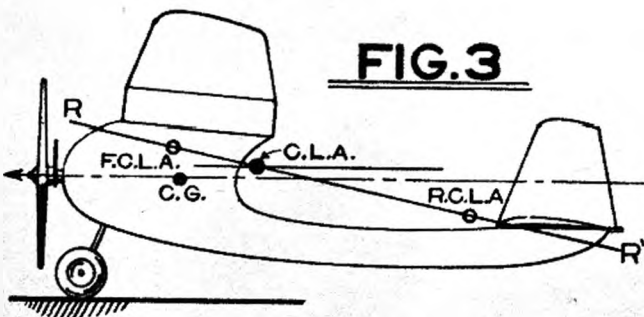

FIG. 3

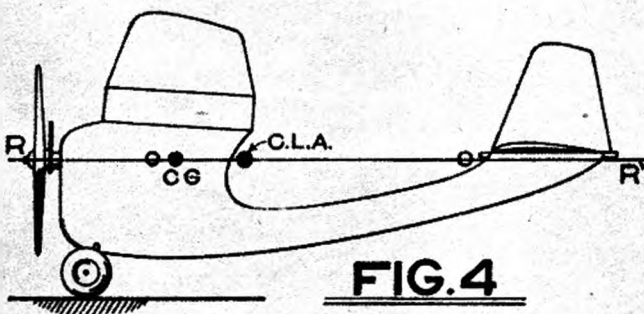

FIG. 4

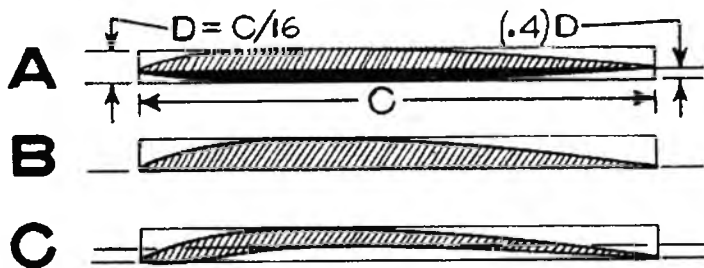

FIG. 5

JUST 14 years and 6 months have passed since the birth of that infernal infant, "Spiral Instability." He has been no ordinary youngster. From the very moment he appeared in the original K. G. (Kovel-Grant) gas model in 1933 he took particular delight in throwing gas models into all sorts of disastrous maneuvers. This young gremlin through the years has caused more arguments and headaches than anything else in gas model history, and all sorts of devices and tricks have been applied to neutralize his ill effects.

The first and most successful means of overcoming spiral instability was the theory concerning location of the center of lateral area. This was developed and offered in practical form by the author in 1933. Since that time many modelers, including the experts, have been trying to disprove it. They have resorted to all sorts of mental contortions and mathematical intricacies to show why the center of lateral area has little or nothing to do with spiral stability, but have proved nothing and only added to the confusion.

One leading modeler even attributes spiral instability to the use of lifting stabilizers. Evidently he has failed to notice that thousands of spirally stable models use lifting stabilizers, and in all cases they have little effect upon the model's good behavior. However, we will leave the discussion of cambered lifting stabilizers to a later article.

This discussion of spiral instability concerns the center of lateral area and is prompted by a letter from Harry C. Brown—the gremlin of spiral instability apparently has paid him a visit. He tells us that he has built and flown a plane called *The Pipe*, a side view of which is shown in Fig. 1, and he comments as follows:

"The first test flight was in October and it spiralled to the left, breaking only the prop. The second flight was to the right and again a crash, this time with no damage. After putting a 1/8" shim under the trailing edge of the stabilizer I let it go for a third time. This time *The Pipe* went straight out shoulder high for about 10 ft., then into a tight left spiral upward."

Mr. Brown goes on to say that on every other flight the ship showed spiral tendencies, either to spiral dive or spiral climb, and he wishes to know the reason for this type of performance.

An adherent of the CLA theory need only look once at Mr. Brown's design to know definitely why it has spiral tendencies. In fact, it would be impossible for the ship to act in any other manner. First of all, it is not because of the cambered stabilizer used but because the CLA is far above the center of gravity (CG) as indicated in Fig. 1. In order to possibly clear up the result of a lot of misinformation concerning CLA effect, let us first consider that this plane is flying in a straight level path. Due to the torque effect of the propeller or to some other external force, the plane banks slightly to the left, arrow B, Fig. 2, and the tail swings slightly to the right, R. The plane does not immediately turn to the left with the bank because its mass or weight tends to keep on moving straight forward, arrow Ff. Consequently it crabs slightly sideways to the right through the air, as shown in Fig. 2. However, as the plane is nosed to the left the propeller thrust Tl, lift forces and other forces tend finally to direct it to the left from the original straight path of flight, Ff, while centrifugal pull Cc, is developed outward by the weight of the airplane.

This pulling force acts at the CG as shown by arrow Cc. Under these conditions the airplane does not fly along a course exactly parallel to the longitudinal axis of the fuselage but crabs slightly to the right, along path Ff, under

(Turn to page 67)

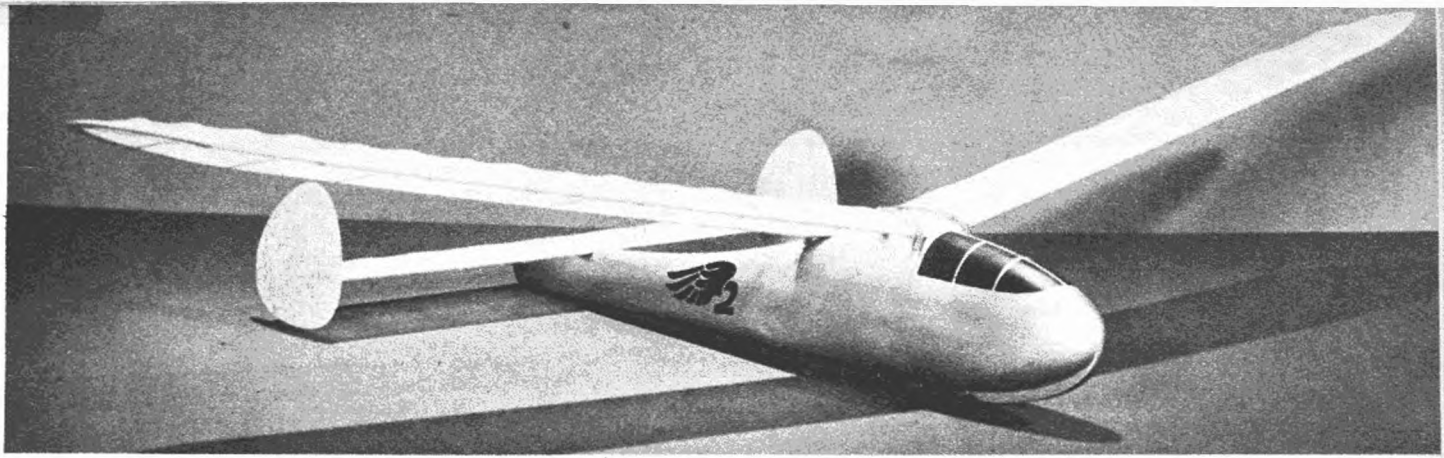

A CLASS C TOWLINER

The hollowed-out fuselage is easy to construct and affords strength and realism for this attractive design

by H. A. THOMAS

THE smallest established class for towline gliders is "C" in which models are grouped having wing area more than 100 but not exceeding 150 sq. in. Our model is a small C job, having a wing area only a bit more than 100 sq. in. To meet AMA requirements it must have at least 1.62 sq. in. of fuselage cross-section and must weigh a shade over 4 oz. If built according to the accompanying plans it easily meets these requirements.

The numerous carving sets now available to model builders which include small curved gouges have led us to employ a perfectly streamlined, hollowed fuselage. It is not a difficult type to build, and for this style of model is superior to any type of built-up construction. To meet the weight rule, the fuselage is not hollowed for maximum lightness and the nose section is left nearly solid for strength and to help balance the model properly.

The wing is of fairly high aspect ratio with false ribs added to help retain good cross-section. Sweep-back is employed since it is held to contribute to directional stability (visualize a model with sweep-back wings being displaced in a yaw, the opposite wing presenting more drag to the airstream and causing a righting effect)—and there is slight toe-in in both fins which aids further in directional stability.

Begin construction with the fuselage, selecting a uniform balsa block and sawing it into two lengthwise halves, vertically. Cement these together again lightly, saw the side profile and then the top outline. Carve away excess wood with a sharp penknife, taking care to retain full width at the widest point. Finish the external shaping including sanding, then separate the halves and hollow the inside as indicated with a sharp, curved gouge. Permanently cement the halves together, carve a recess for the 1/8" plywood skid and cement it securely in place. Dope and sand the fuselage, adding wood filler if you care to smooth it to this extent. Bend the wire towline hooks and cement them to the fuselage belly.

Select uniform 1/16" sheet for the wing and stabilizer ribs. We suggest you make metal templates of these and trim around them with a sharp pointed model knife. The wing halves are next completely assembled, the trailing edges being tapered and the leading edges rounded a bit. Cut the dihedral joiner and taper it to fit the angle of sweepback. Notch the center ribs for it and cement it firmly in place, checking the dihedral at the same time. Trim out the two fins of 1/16" sheet and sand them to streamline section.

Covering material for wing and stabilizer should be light Silkspan or jap tissue. Using thick dope as an adhesive (add cement to thicken it), work from the center outward in covering the frames, dopping down about two rib stations at a time. Pull out wrinkles as you go and trim the edges flush. It is best to cut separate, smaller pieces of the covering material for the wingtip sections to avoid wrinkles. "Water dope" the wing and stabilizer lightly after covering, using a cotton swab or atomizer, and permit them to dry thoroughly before applying two coats of thin dope. Cement the fins to the outer stabilizer ribs.

(Turn to page 63)

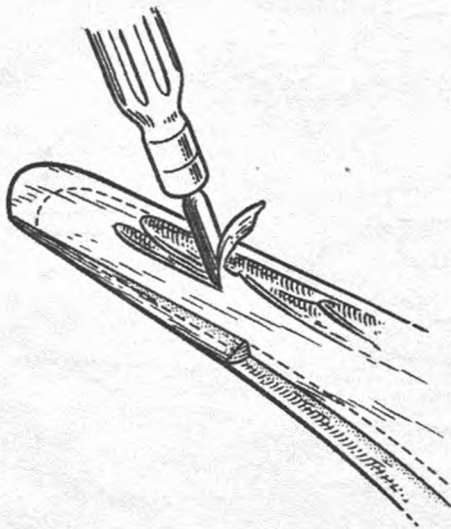
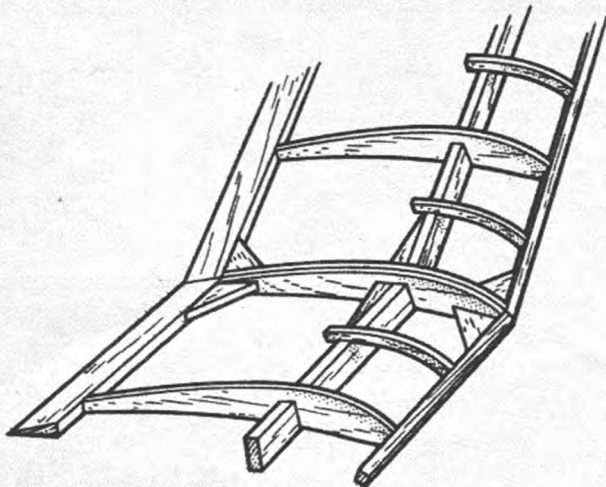

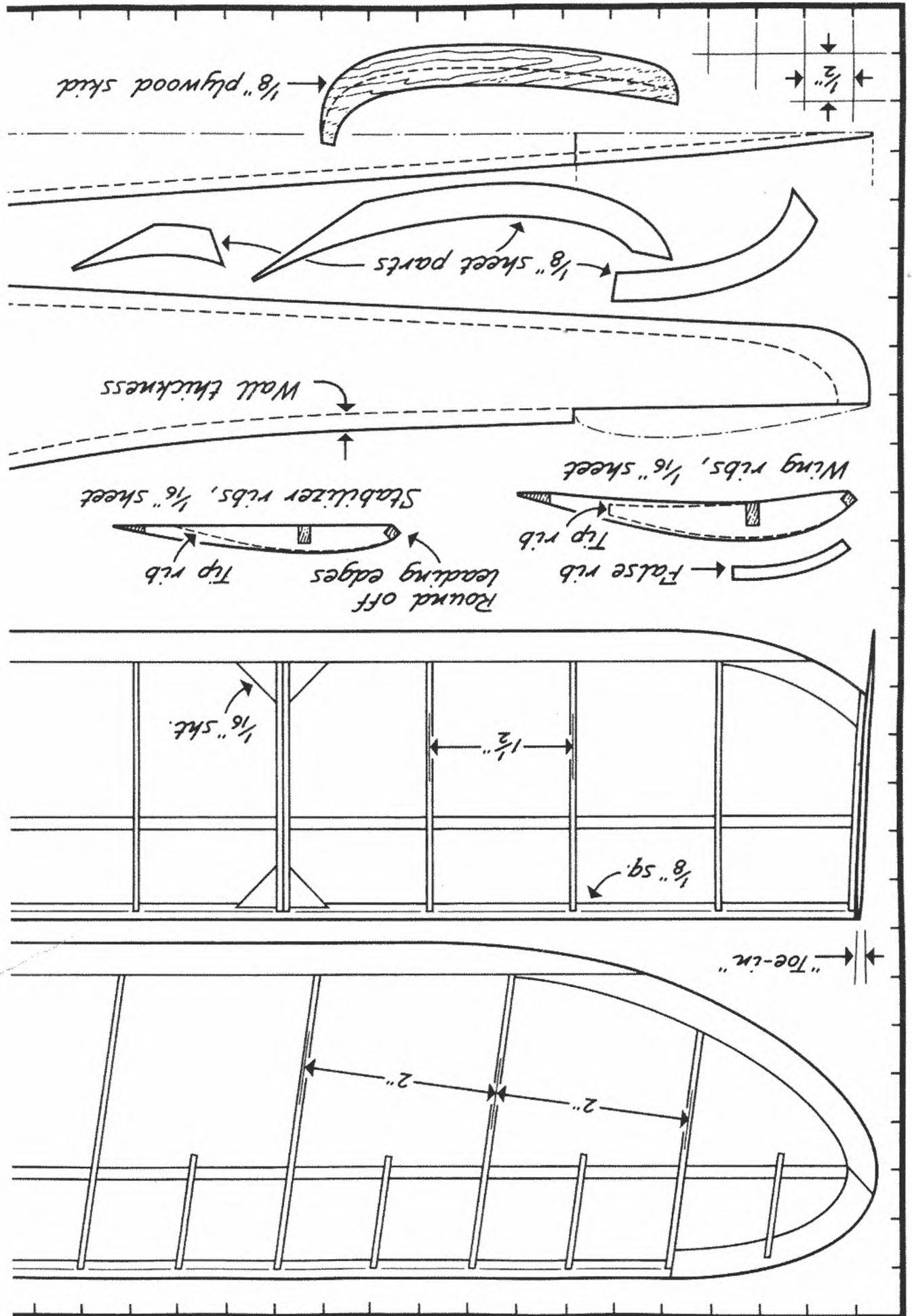

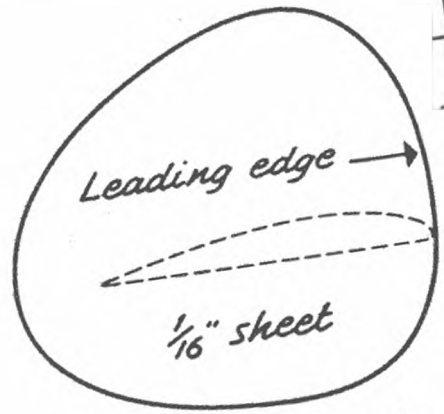
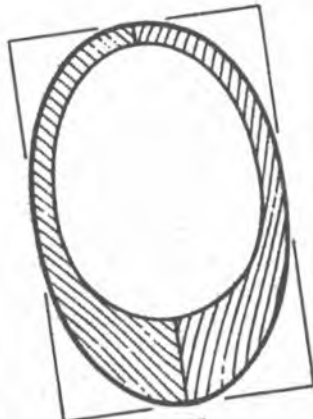
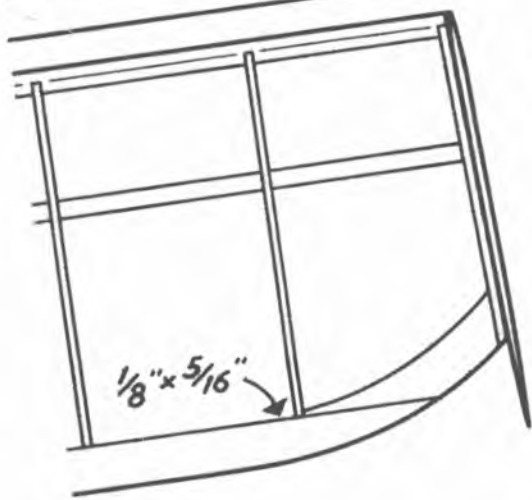
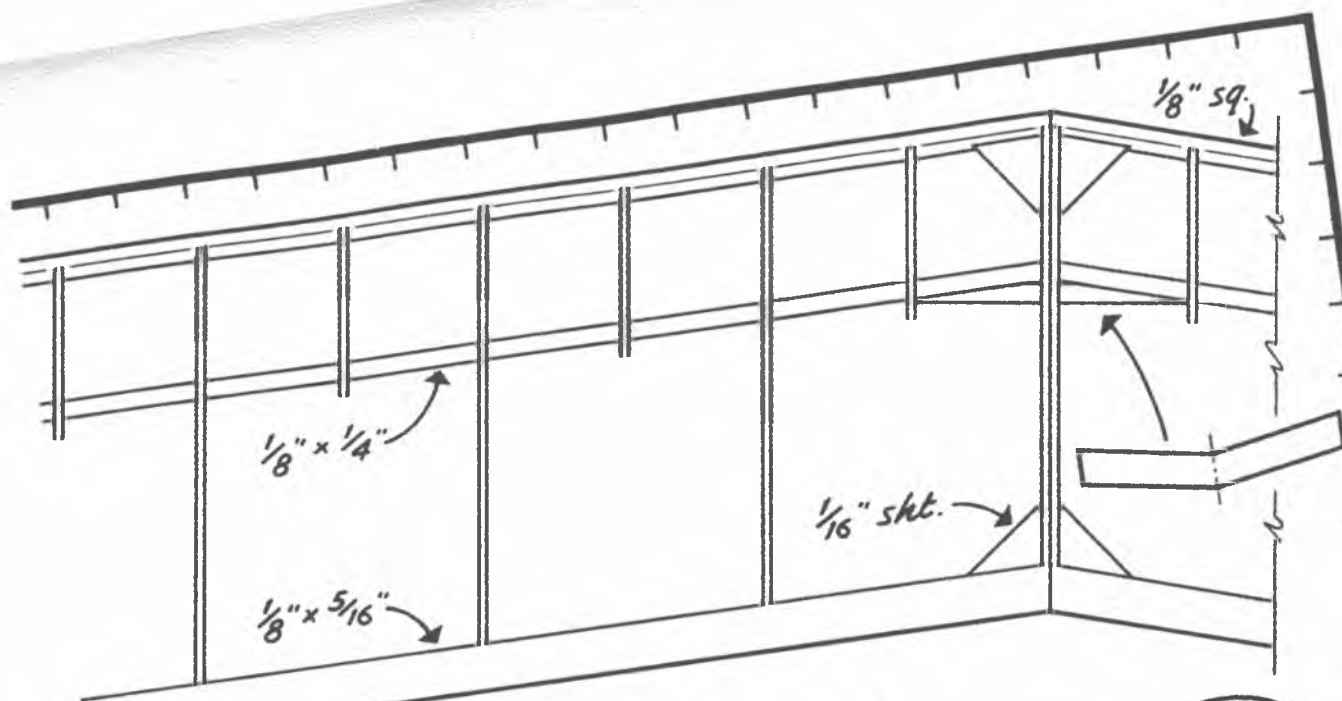

X-section = 3.2 sq. in.

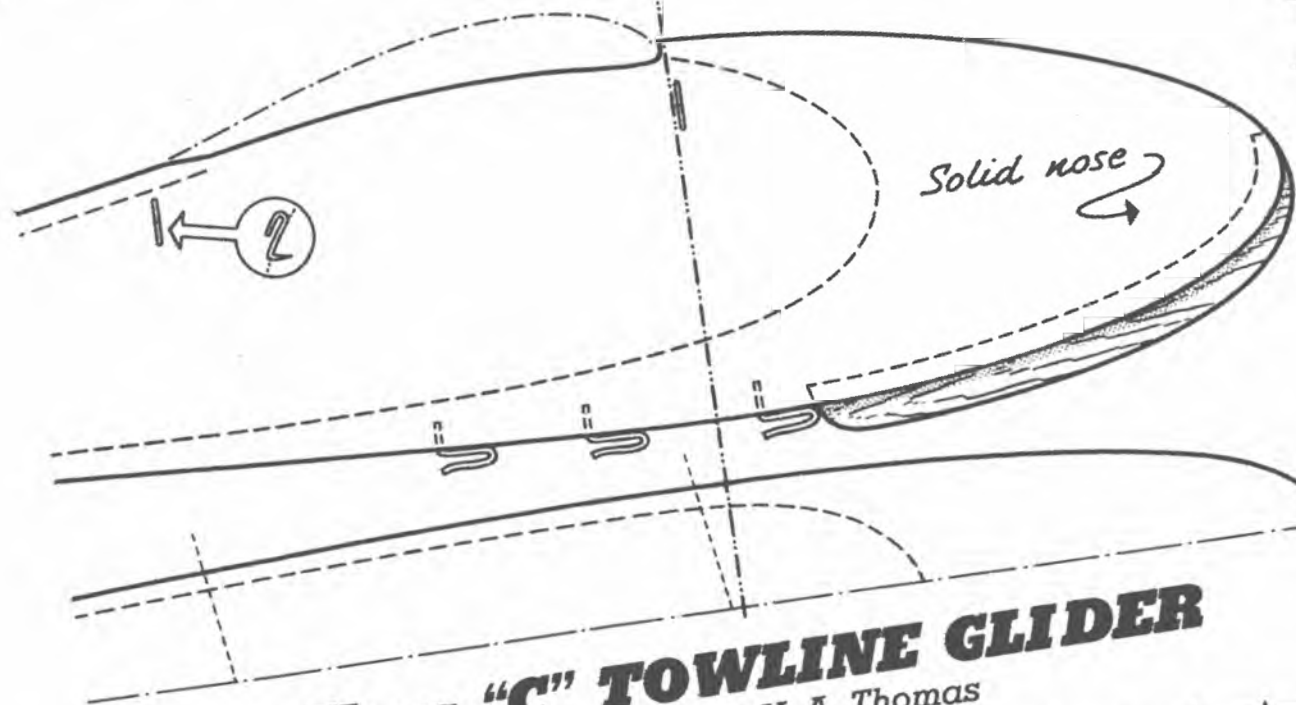

Class "C" TOWLINE GLIDER
 designed by H. A. Thomas

Meet the RUDEVATOR

by H. H. Owbridge

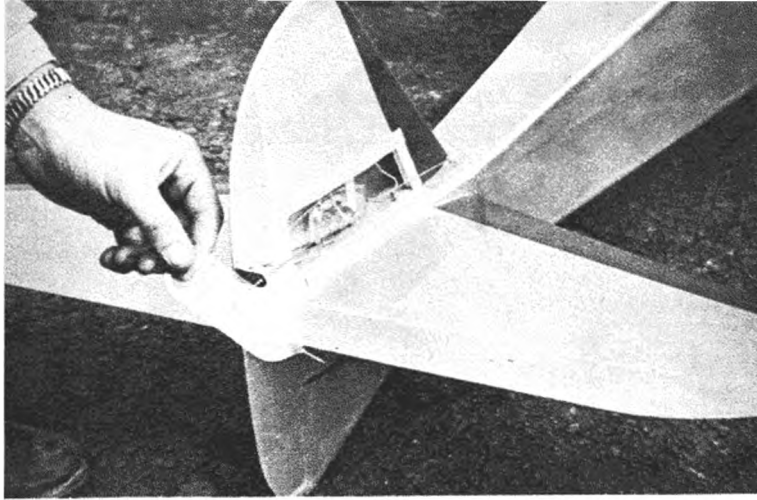

General view of Rudevator installation on test ship

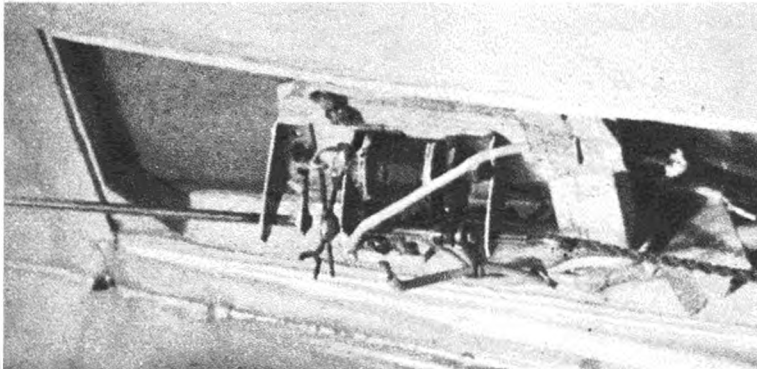

Actuating mechanism is very compact and light

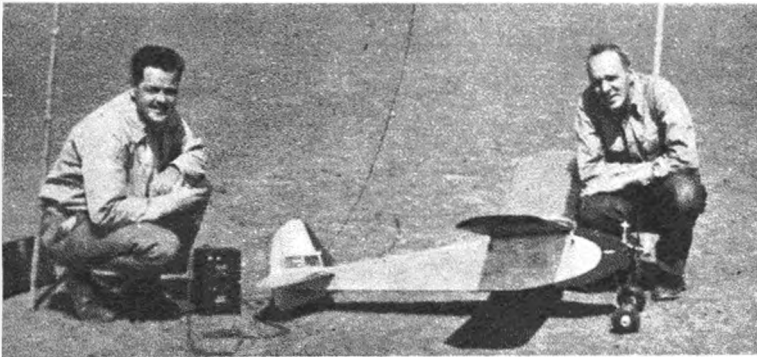

The author (left) and Dick Schumacher ready to fly
Control receiver takes little space in the large cabin

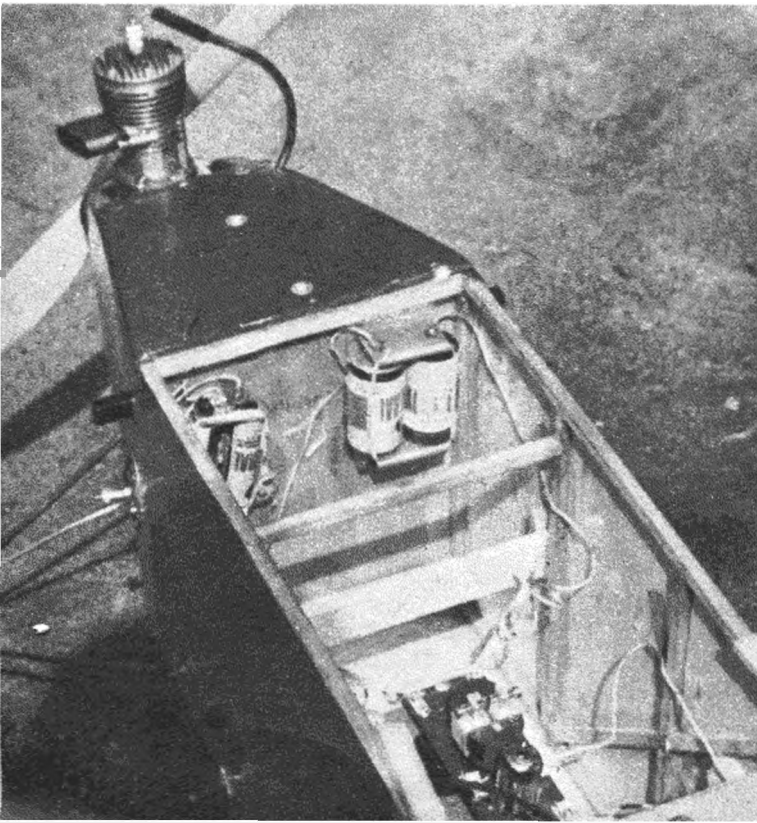

AN article entitled "Simplified Radio Control" by William A. Rhodes in the July 1947 issue of M.A.N. ended my three and a half years of effort to "discover" a really simple control that would advance the art to the stage of mass acceptance. In this article the author stated: "I do not contend that this unit is in its highest state of development, but it has lots of possibilities and I hope that others will conduct further research to improve upon it, keeping in mind however not to let it grow into a nightmare of complication as have some units I've seen."

Well, we both got our wish. Bill Rhodes showed me the really simple control and at the same time he found someone to "conduct further research to improve upon it." Together we believe we can offer our fellow enthusiasts the most control for the least weight on record.

As readers of that article will recall, the control as Rhodes conceived it is really a rotary tab that combines the duties of rudder and elevator. Since it is probably here to stay, let's accept it into the family of model airplane tricks and give it the nickname "Rudevator". Now, with flying time as a measure, the rudevator is very young yet. Bill Rhodes has flown it a little and so have I. But so far as I know, that is all. Like the idea of control line models and the now famous Good Brothers escapement—both of which started out with limited usage—the rudevator will grow in ability with flying time. We feel that its present ability compared to its utter simplicity gives it a good start.

To begin with, the rudevator is completely coordinated with the operator. There is no need for counting or remembering past control positions. Then, too, neutral is automatic when the signal is off. If you get excited, a flick of the switch puts you back in the free flight class where you can wait until your heart stops pounding. Besides rudder and elevator, the rudevator includes an ignition switch. Go off and fly yourself silly until you think you're going to be late for dinner. Then cut the ignition, bring the ship in, pack up and go home.

The rudevator will fit any free flight model that will lift a receiver. And receiver installations complete with batteries are getting down below 8 oz. these days. The rudevator answers to a normal carrier wave and a simple pulse at that—no audio tone or timed signal length is necessary. The rudevator is simple to install. You know that old free flight job that never could get high enough on a 10 second motor run to win anything? Well, don't burn it. Give it a new lease on life with radio control. You don't have to rework the tail to hinged surfaces or install control rods either, for the rudevator does all that. As for that old engine that's low on compression, quit trying to sell it for more than it's worth; it's ideal for radio control. Unless however you intend to use your radio controlled model to go off hunting thermals in a free flight contest.

First let's review the rotary tab itself. It too has improved a little. As seen in Fig. 1, it is made of 0.020 celluloid sheet and the control area is the large area between the two protruding tips. This area can be adjusted at any angle on the shaft from 10 to 50 degrees depending on how fast you wish the ship to respond. Even two airplanes the same size may need a slightly different angle or area because one may be more stable than the other. A general rule is: 1 sq. in. for each foot of wingspan, and set at 30° or 40° to the shaft as a start. It's not too important however since the control can be turned on and off quicker than a water faucet. Just pick a calm day and have an engine timer aboard for that first flight. The small tabs at the tips of the rudevator are set at an angle over a teakettle so they will propel the main surface around in the slipstream. Ours turns about 100 rpm which is plenty. Since the shaft is clamped to the center of the rotary tab, no balancing is required. Check it out in a car before you fly. If it starts rotating at 10 mph, it's all right. Our tab has a control area 1-1/2" x 4" with the cor-

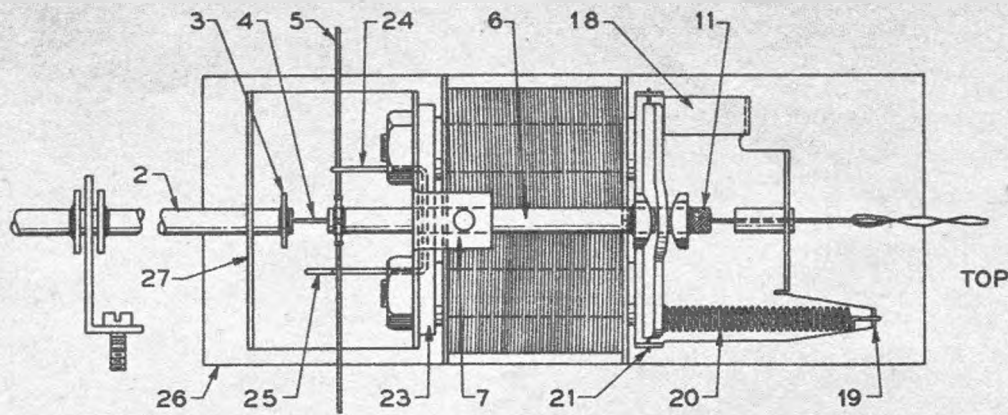

IGNITION SWITCH DETAILS
(8-9) OMITTED IN TOP
VIEW FOR CLARITY

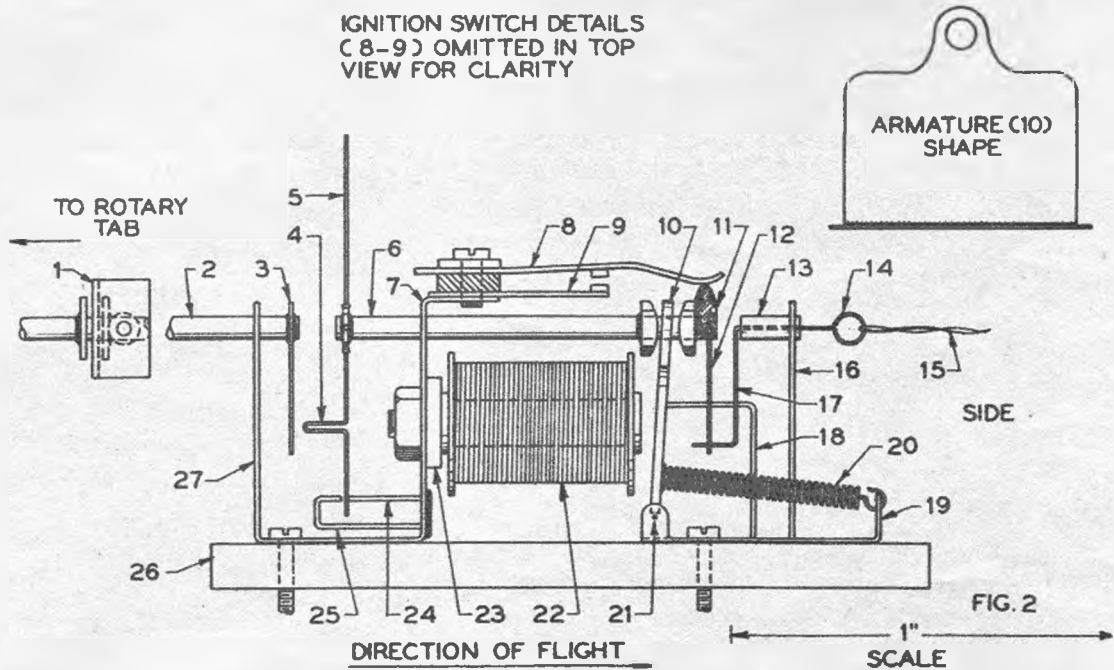

ners rounded off. The propelling tabs are 3/4" long by 3/8" wide. For a 7 ft. span model this area is a little on the small side, but then we are beginners, too.

Let us assume we all understand that when the ruderator is turning free it is in neutral. And for those who think the model will show the effects of any aerodynamic vibration, let them try it sometime. The mass of the model and the stabilizing effect of the fixed tail surfaces just won't let the ship respond while the ruderator is rotating. Now, to produce rudder or elevator control, all that is necessary is to stop this rotary tab in any one of four positions. Let's forget about the other four intermediate positions since this is a step control rather than a proportional control, and the amount of turn or dive you get depends upon how long you hold the control on. Let's not worry about climbing turns either, since with only two engine speeds (go and no go) the model would only stall anyway and we can do that with the elevator. Diving turns yes; any model with a single control will dive if the rudder is held long enough, especially if the turn is with the engine torque.

Fig. 2 shows the brain behind the control. To assure coordination with the ground operator, the ruderator uses a form of escapement. It is really a stop that is positioned by an escapement. The fact that the stop has two directions of motion (rotary and translatory) does the trick. Four spokes (#5) protrude from the short escapement shaft. The shaft is connected to the armature of the double coil electromagnet by means of a bearing (#10) which will allow rotation of the shaft. Torque to rotate the escapement shaft is provided by the loop of 1/32" square rubberband (#15). Tension in the rubber motor is isolated from the escapement shaft by a small music wire crank (#17). Now, motion of the armature (when energized by the receiver sensitive relay) will step the four spoke wheel around one-quarter turn at a time through the labyrinth escapement stops (#24, 25). However, one spoke has a stop protruding from it (#4). When the electro-magnet is energized, this stop engages

(Turn to page 64)

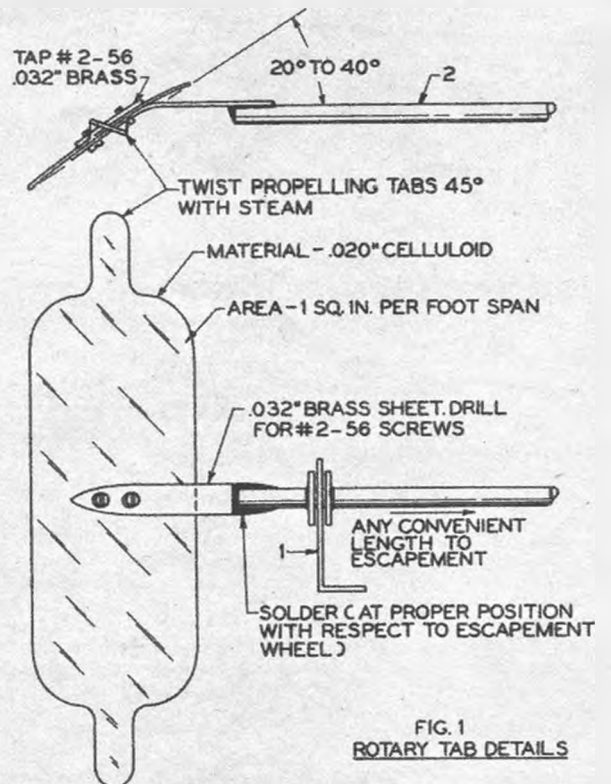
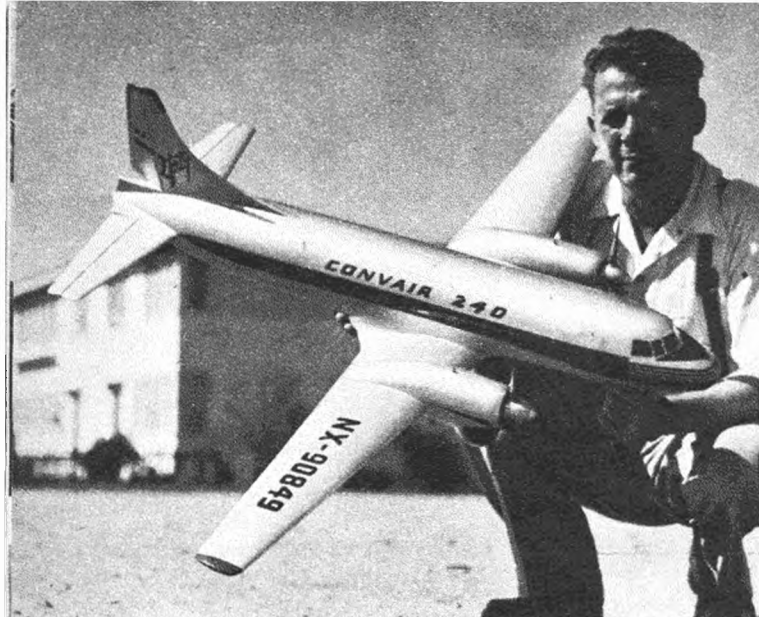

FIG. 1
ROTARY TAB DETAILS



No. 1 Frank Hernandez' completely equipped model Convair 240



No. 2 Brian Fairey, Brian Eccles & Martin Ollis at Warsaw Aerodrome



No. 3 Ancient realistic Bleriot Monoplane built by Joe F. Park

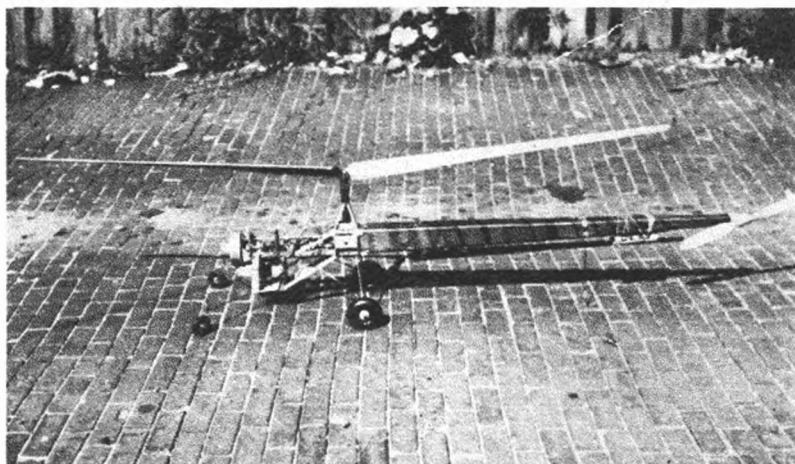

John E. Burkam perfected this gas powered model helicopter

AIR WAYS

News of Model Airplane Experimenters All Over The World

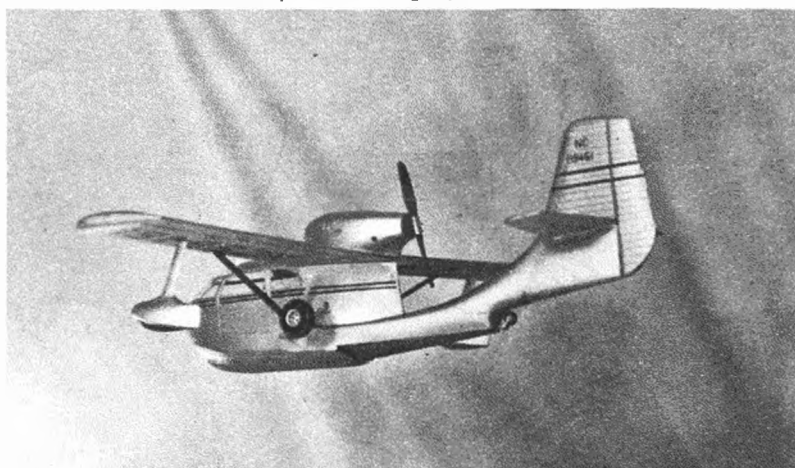

Detailed solid scale Republic Seabee, built by Robert C. Mikesh

MORE HELP FOR MODELERS. The Veterans of Foreign Wars, national veterans organization, will undertake a vigorously expanding program for model aviation, in cooperation with Air Defense Command, National Guard, and the Civil Air Patrol. The V.F.W. pioneered in model plane activity through the work of Carl Hopkins of Clarksburg, W. Va. who established one of the country's oldest model clubs in 1927.

The V.F.W.'s 10,000 posts will engage in the new program through formation of local model clubs, or aid to clubs already in existence. A large scale organization was inaugurated in Kansas City recently under joint sponsorship of V.F.W. and

Gold Stars United of American War Dads. This unit will be named in honor of Lt. Robert Mooney, who was shot down while serving as fighter pilot over China in 1942. C. R. Mooney, Lt. Mooney's Gold Star Dad, hopes to establish similar "living youth memorials" throughout the nation.

Maj. Gen. Claire Chennault, famed leader of the "Flying Tigers" is a staunch supporter of the new program, and has offered to contact 1,000,000 Chinese boys who are interested in model aviation. Strong indorsement is also given by J. Edgar Hoover, James H. Doolittle, Eddie Rickenbacker and many others.

RESULTS OF THE ELECTION of

A.M.A. officers for 1948 have been announced. New president will be C. O. Wright, of Topeka, Kansas who, through his long experience with association work in the central states, is expected to lend great impetus to the national model aviation movement. Russell W. Nichols of Washington, D.C. will continue as Secy.-Treas. and the following District Vice Presidents and Contest Board Members were elected:

District I—VP David Hunt, West Hartford Conn.; CBM's Bernard Collins, Providence R.I. and Carl Hermes, Bridgeport Conn. District II—VP John Schneider Scotia N.Y.; CBM's Harold G. Bradish, Schenectady N.Y. and William Fletcher,

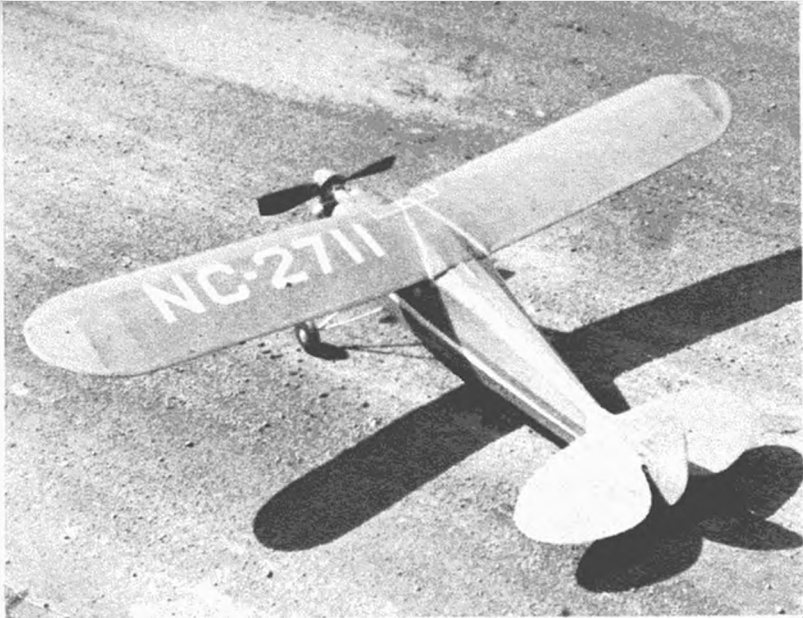

John M. Olson hopes to add radio control to this model Cub Coupe

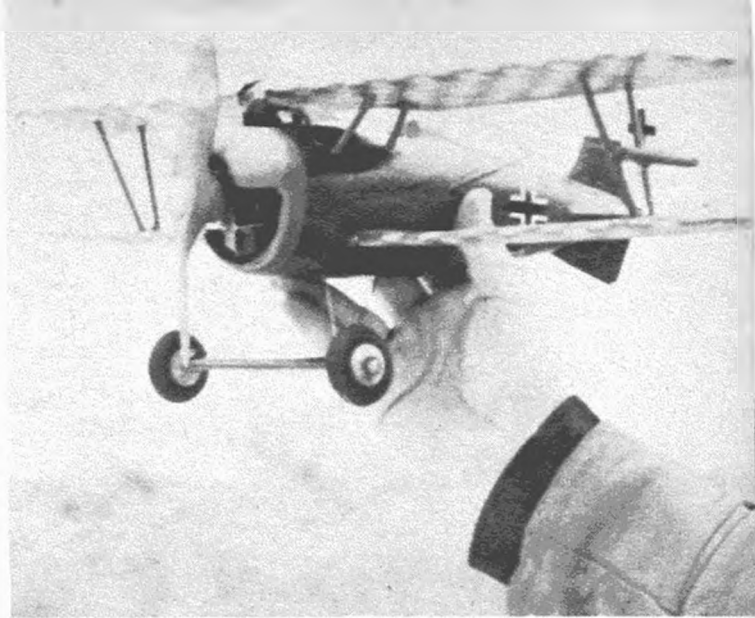

Siemens Schuckert D4, a WWI job constructed by Dan Weinberg

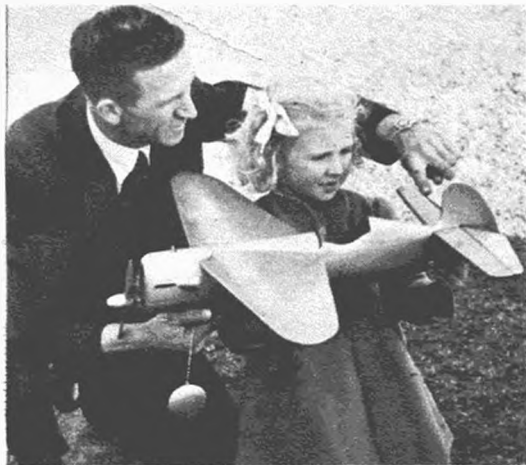

W. Van Rensburg built this Whippersnapper



Jet powered U-control made by Lawrence Gostomski

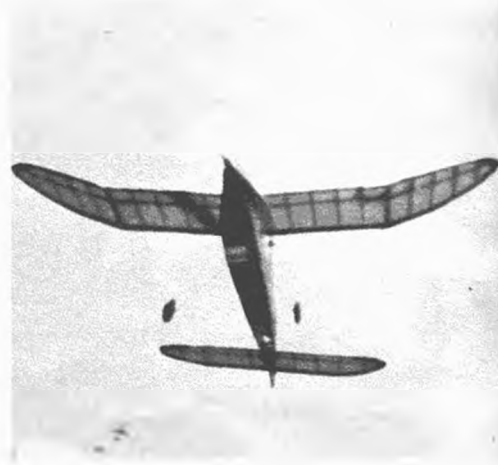

Thomas Gabriel's modified Jabberwick



Korda Wakefield winner has afforded fine results to Alfred Walsky

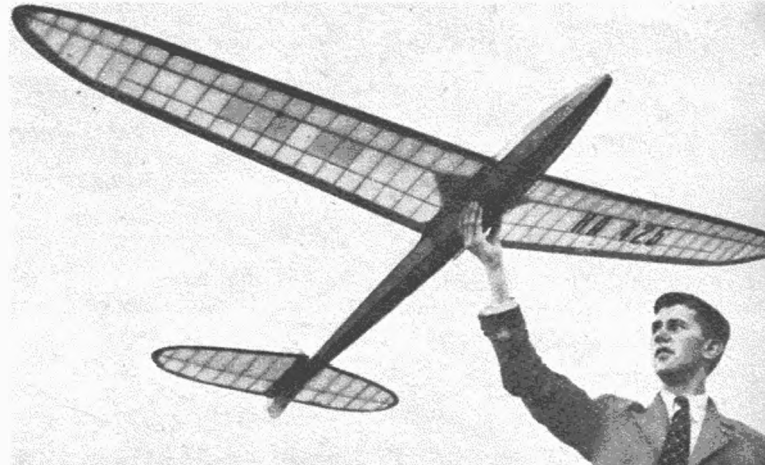

From Holland, G. van der Linden sends picture of his sailplane

Elmhurst N.Y. District III—VP John W. Hillegas, Cleveland Ohio; CBM's Carl Hopkins, Clarksburg W. Va. and Chester Lanzo, Cleveland Ohio. District IV—VP Frank Parmenter, Hampton Va.; CBM's Dr. Walter A. Good, Silver Spring Md. and John Worth, Hampton Va. District V—VP H.R. Hudson, Atlanta Ga.; CBM's C. C. Caviness, Atlanta Ga. and C. H. Thornton, Jacksonville Fla. District VI—VP Frank Nekimken, Indianapolis Ind.; CBM's Carl Goldberg, Chicago Ill. and Al Yount, St. Louis Mo. District VII—VP R. F. Watson, Des Moines Iowa; CBM's Frank Sposite, Detroit Mich. and Curtis Janke, Sheboygan Wis. District VIII—VP Rogers Barton, College Station Tex.;

CBM's John Clemens, Dallas Tex. and Rogers Barton, College Station Tex. District IX—VP Leo Rutledge, Wichita Kans.; CBM's C. L. Bristol, Cheyenne Wyo. and James McClelland, Wichita Kans. District X—VP Ray Acord, L.A. Calif.; CBM's Jack Douglas, Salt Lake City Utah and Harvey Robbers Sr., Oakland Calif. District XI—VP Jim Walker, Portland Ore.; CBM's Elmer Roth, Salem Ore. and E. R. Nichol, Portland Ore.

WE HEAR FROM AN old correspondent, Joe Bligh of *Atlantic City Sky Blazers*, that activity in that vacation spot is high despite a tough winter. Indoor flying is practiced in the world's largest auditorium (seats 41,000 according to Joe)

where high time for the city is 12:47.0, made by John Ginnetti. Joe passes on an interesting tip which should be useful to anyone living near the sea. *The Sky Blazers* have had the usual winter trouble in that their baseball diamond control line field is either a quagmire from alternate freezing and thawing, or is covered with a treacherous blanket of snow. They have the problem licked now, however, as they simply do their flying on the ocean beach at low tide. Every high tide sweeps the sand smooth, packs it down, and clears away snow if any has fallen. They have had no trouble with noseovers or sand in engines, and have been able to
(Turn to page 42)

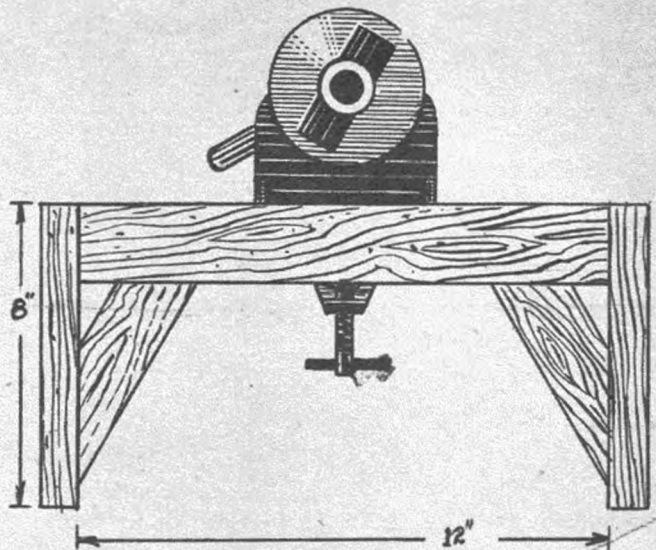
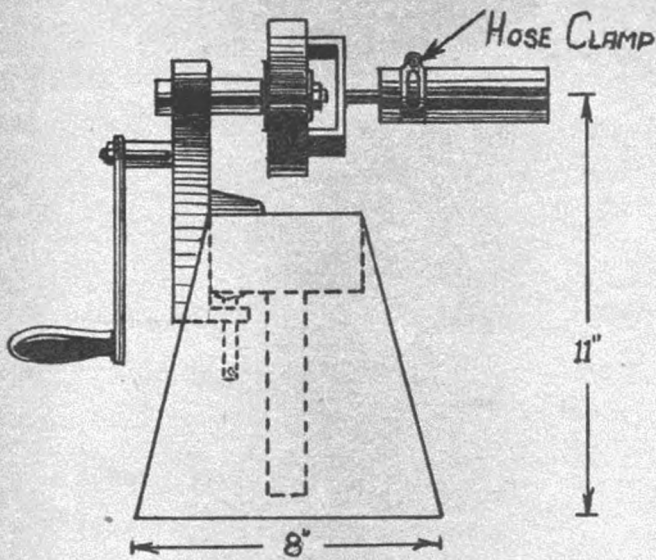

INERTIA STARTER

This starter uses no battery or wires—a strong arm is all you need

by DALE SPRINGSTED

HERE'S a starter anyone can make and operate. No batteries, no motor, no carrying case needed—just a hand grinder and a small flywheel from your neighborhood junk shop. This starter is constructed as follows:

Any grinder can be used; this particular starter utilizes one having a 10 to 1 gear ratio, but there is no reason why a higher or lower ratio would not work out well. The flywheel is a piece of turned steel 4" in diam. 1" thick, about 3-1/2 lbs. in weight. A hole the size of the shaft on the grinder is drilled in the center of this wheel. A piece of common 3" channel iron 1-1/2" wide was drilled in the center with the same size hole as in the flywheel. Next a piece of round cold rolled stock also of the same diameter was inserted through the flywheel, the channel iron placed in position on it and welded to the flywheel. Then the channel was welded to the cold rolled bar, and the excess bar cut off inside the channel. Caution was used in this operation to make certain that all parts lined up since it is important that there be no wobble in the outer shaft.

Common automobile heater and radiator hose was pressed on the outer shaft and clamped in place with a standard hose clamp. This assembly is used on the grinder in place of the stone, but the latter may be replaced at any time.

The bench is very simple to construct. The main crossmember is 2" by 4", while the legs and gussets are 1" stock.

To operate the starter—hook up your booster batteries in the usual manner. Place prop spinner in the cone formed by the rubber hose, and have your mechanic crank at a moderate speed. We found it advisable to prime the motor, retard the spark, and have the needle valve setting about 1/2 turn richer than the regular operating mixture of the motor. A word of caution though—don't try to use a plastic spinner since the hose cuts into it and leaves unsightly ridges where it was in contact.

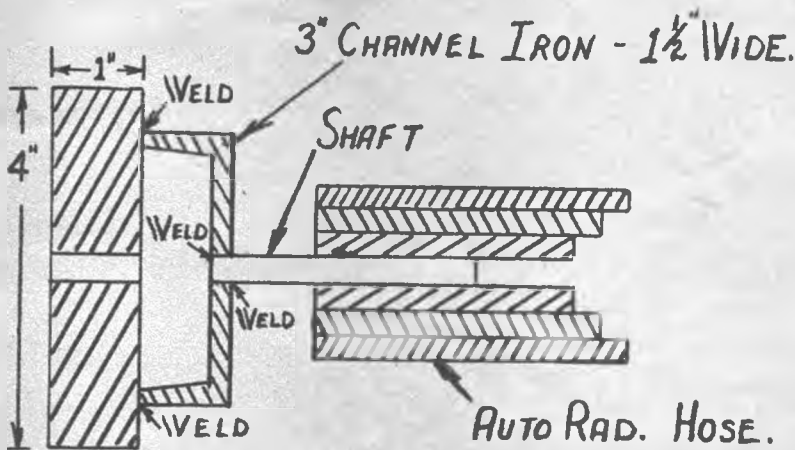

CROSS SECTION DETAIL OF FLYWHEEL

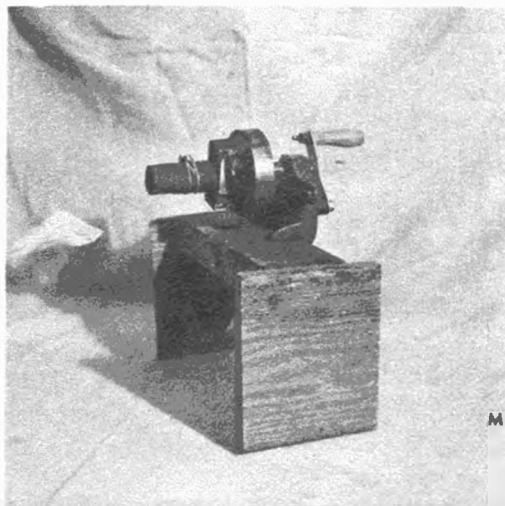
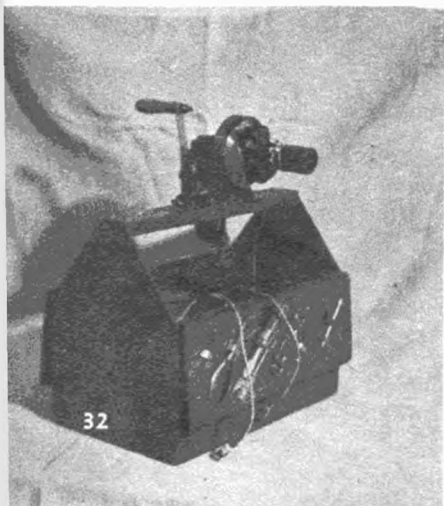

Tester for Model Sparkplugs

By Ray Rusher

A HANDY miniature tester suitable for model sparkplugs can be readily made by the model engine user from the types of neon tubes or bulbs shown in drawing 1. Such a tester will enable you to determine whether the plug is sparking or not, without having to remove it from the engine.

A neon tube is preferable because it produces a brighter glow or flash during tests. If you are unable to purchase these, buy a sparkplug tester (drawing 2) at any auto supply store. They are 4" or 5" long, provided with a clip so they can be carried in the pocket, and usually cost 25c. If unavailable, a line tester for electrical and radio work (drawing 3) or a night light (drawing 4) can be purchased for 25c to 50c. Line testers and night lights will be found to contain the bulb type of neon light.

To remove the neon tube from a pocket sparkplug tester, cut through the transparent plastic barrel at a with a hack-saw, or saw off the metal cap at b if the tube is of glass, being careful not to damage the neon tubes inside. These testers are usually provided with two neon tubes, so you will have two model sparkplug testers.

To remove the neon bulb from a line tester, saw the sleeve at c and pull the assembly of bulb, resistor and leads (drawing 5) out of the transparent plastic protective housing, being careful not to break either of the fine wires extending from the bulb. To remove the neon bulb from a night light, remove the fibre cover at the base, and the wires leading from the terminal prongs to the resistor and bulb will be exposed. Drawing 8 gives details and shows the relation of parts. Carefully break the wires loose from the prongs and the resistor and bulb can be pulled out.

Your miniature sparkplug tester can be made from one of the neon tubes by cementing a piece of black paper around two-thirds of the tube as in drawing 6 to serve as a background for the glow or flash in the tube and as a light shield so that the glow can be more readily seen, especially in broad daylight. The intensity of the glow can then also be more accurately judged. This shield can usually be omitted for testing on the workbench. Drawing 7 shows a crosssection through the tubes and shield of drawing 6. The shield also serves as a protector for the glass tube of the tester when the tester is kept loose among other small parts, bolts, etc., in your tool or kit box.

To use the tester, merely touch one of the metal end caps to the top of the sparkplug while the engine is running slowly, or while turning the prop over by hand. Hold the other metal end cap in your hand and the glow or flash will be brighter than if you held the glass. You will not receive a shock unless you are touching ground (the engine) also. Even then the shock will only be slight due to the high resistance of the neon gas in the tube. A bright glow or flash indicates a properly firing plug. See the following chart for a full outline of possible tests.

TEST CHART

Engine turning over by hand	Indicates
no flash.....	dead sparkplug or high tension current too weak to cause spark
dim flash.....	sparkplug fouled or current too weak to cause satisfactory spark

medium flash...satisfactory spark
bright flash.....excellent spark

Engine running slowly

Indicates

dim glow.....sparkplug fouled but sufficient spark to run engine

medium glow...satisfactory spark
bright glow.....excellent spark

If the sparkplug is fouled with carbon and/or oil so that there is secondary current leakage, the spark across the gap of the sparkplug will be lean and weak. This is indicated by a dim glow or flash in the tester.

The high tension lead can also be tested by touching the sparkplug tester to the insulation while rotating the engine by hand. A bright flash indicates possible leakage, and a dim glow or none indicates a grounded lead. No flash may also indicate a

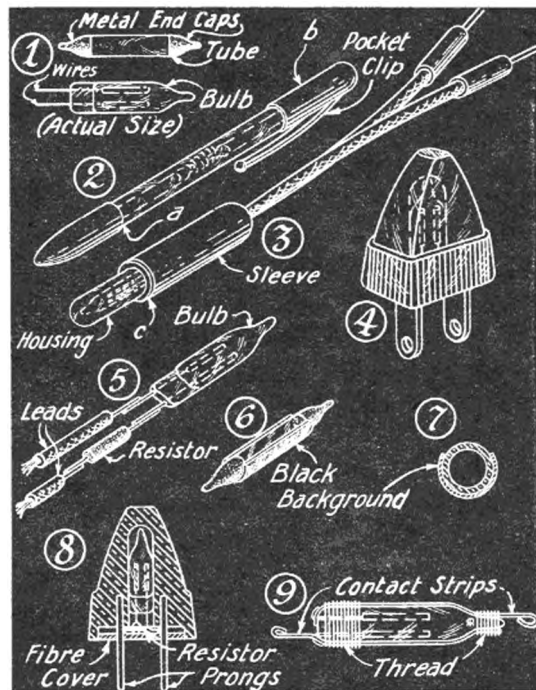

broken wire inside the insulation and therefore an open circuit.

By starting at the sparkplug and moving the tester along the lead, a change from no flashes to flashes will indicate the point of break.

Drawing 9 shows how a neon bulb from a line tester or a night light can be adapted as a model sparkplug tester. Two strips of tin or brass 1-16" wide serve as contact strips. The wires from the base of the bulb are soldered to the strips after passing through small holes drilled in them. Omit the resistors of drawings 5 and 8 as they will cut down the current through the tester. Wrappings of thread hold the strips in place. The wires are then soldered to the strips, using the soldering iron sparingly.

Then cement the threads to the strips and bulb.

It is suggested that a rheostat be cut into an ignition circuit and the sparkplug removed from the engines so that the spark can be observed, or a similar test setup made. By then adjusting the rheostat for successively weaker sparks and noting the effect on the flash in the tester you can familiarize yourself with its use. Make some tests in broad daylight and some under restricted lighting conditions to see the difference between the appearance of the flashes.

Model Hobby and Handicraft Dealers

STROMBECKER
INTRODUCES ANOTHER GREAT SALES-GETTER

Newest in a series of solid wood model assembly sets. All parts ready-shaped.

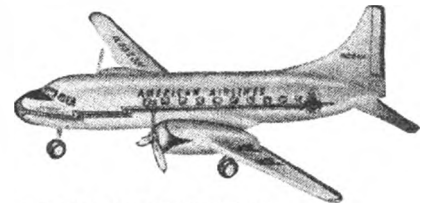

CONVAIR FLAGSHIP

Twin-engine Consolidated-Vultee Transport, solid model assembly set. Scale 1/64" to 1 ft. Dimensions when assembled: wingspan 10", length 8 1/4". All wood parts Western Pine (not balsa). Complete with decal trim and insignia, metal props, tricycle landing gear, illustrated instructions, wood filler, glue, sandpaper. No. C-38. To retail at 69c.

Other sure-fire items for rapid turn-over:



Piper Cub Super Cruiser. No. C-34. 50c

Piper Cub Super Seascout. No. C-37. 50c

DC-6 Flagship. No. C-36. \$1.00

DC-3 Flagship. No. C-35. 59c

P-80 "Shooting Star". No. C-32. 59c

P-61c "Black Widow". No. C-33. \$1.00

B-24 Liberator. No. C-76. \$1.69

B-29 Superfortress. No. 250. \$2.50

Consolidated Flying Boat. No. C-8. 45c



DeWitt Clinton Train. No. 1831-GT. \$1.00

DeWitt Clinton. No. 1831-c. 50c

Wm. Galloway Train. No. 1837-BT. \$1.00

Wm. Galloway. No. 1837-C. 50c

Rock Island Rocket. No. 1937. \$1.50



Battleship California. No. C-16. 45c

Cruiser Indianapolis. No. C-11. 45c

Aircraft Carrier Yorktown. No. C-13. 45c

Destroyer Warrington. No. C-14. 45c

Submarine Nautilus. No. C-15. 35c

DEALERS: CONTACT YOUR LOCAL JOBBERS!



Model Fans! See your favorite hobby dealer! For FREE catalog describing complete model line write to

STROMBECK-BECKER MFG. COMPANY
Dept. MN-4, MOLINE, ILLINOIS



THE Mohawk Chief

NEVER BEFORE
AN ENGINE LIKE
THIS AT A PRICE SO LOW

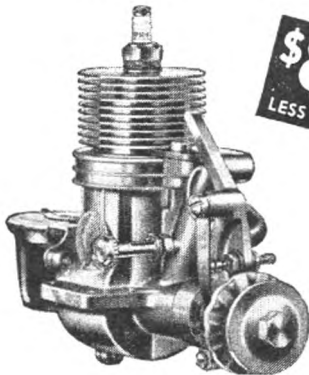

\$8.95
LESS COIL

**Compare THESE
QUALITY FEATURES WITH
ENGINES COSTING TWICE
AS MUCH . . .**

One-piece steel cylinder for even heat flow • Deep cylinder fins for efficient cooling • Aluminum crankcase with strong mounting lugs • One-piece crankshaft, hardened and ground • Rotary valve for high performance • Impact fuel induction for high speed • One-piece steel piston, hardened and precision fitted to the cylinder • Aluminum connecting rod, heat treated • Adjustable timer, easily regulated • Precision needle valve for fine adjustment • Bakelite gas tank permits use of "hot" fuels • Gasoline tank mounted on crankcase • Large volume exhaust stack for rapid scavenging • Champion spark plug • Hardened propeller flanges • Replaceable propeller bolt.

SPECIFICATIONS

Displ. .299, B class
Bore .760 Stroke .660
R.P.M. 2,000 to 10,000
Wt. with tank 7 oz.

**Every Engine
BLOCK TESTED
and
GUARANTEED**

MOHAWK SPITFIRE COIL for top performance for any miniature motor. Produces intense spark, low battery drain. Complete with high tension lead . . . only \$1.95.

See your local dealer or order direct from factory. Add 25c for handling. Or send only \$1.00 and we will ship C.O.D. for balance.

**MOHAWK ENGINEERING CO.
MOHAWK, NEW YORK**

WEST COAST TIPS

by JOHNNY DAVIS

CONTEST time is here! Already we have received word that this year's All Western Open, sponsored by the Aviation Committee of Los Angeles Junior Chamber of Commerce, has set June 25, 26, 27 and 28 as the dates for this biggest of All Western Contests!

Tom Engelman, able chairman of last year's show, informed us he would be a contestant this year instead of an official, and that a well known eastern model builder and contest director who has taken up residence in Southern California will be selected to head up this year's committee. Since the new man has not been definitely promised as yet, his name is withheld; but if he is selected we feel sure you will really enjoy the meet—he has plenty of that old touch which makes things go right.

Speaking of the Western Open always brings to mind that great champion Frank Cummings, two time winner of the Western Open's highest award, the Sweepstakes Championship. Frank is an all around excellent model builder—you name it and he can build it; moreover, he can usually win with it, too!

At last year's Nationals we were the most surprised person in the world when Frank showed up at the control line circles with a sleek little Class III speed ship powered by a K & B Torp. He said, in answer to our query: "Oh, I just thought I might pick up a couple more points." Imagine that! Think of all the time the average fellow spends on a racing job to get everything right and not only that but learns how to fly besides. Does Frank do that? Heck, no! He just takes time out from building indoor jobs (which, incidentally, he makes as well or better than anybody we've seen except Bill Atwood) and whips up a nicely designed speed job that immediately is a threat to all comers.

Well, Frank didn't exactly set the world

on fire at the Nats in control line, since he was pretty busy just winning the National Championship and a Piper Cub—but look out, fellers, he'll probably attend to that little chore next year.

He really excels in rubber powered events and indoor flying. This is the field where perhaps his real talent exists. There is a certain indefinable "feel" necessary to get the most out of indoor jobs that leaves the average model builder out in the cold. Maybe it isn't necessary to be born with the "touch", but if it is possible Frank must have been born with it.

All this flowery praise is just a build-up to tell you that we pick Frank Cummings to nose out a big field for top honors again this year. Any bets, gentlemen?

We find that the Snafu boys—Ed Lansberg, Doug Morgan, Don Gulotta, Bobby Brown and others of the stunt flying control line hot shots—have changed their spots. Not literally, just figuratively speaking, that is. It seems the other day some of the "control line" boys racked up some terrific flying times with "towline gliders" no less. How about getting ready for the Sweepstakes awards in the senior class at the Western Open? You free flight and towline standbys had better keep an eye on Don Gulotta who turned in a 27 minute flight on a T.L. glider the other day.

They are also building free flight jobs night and day and getting them tuned up. You know this year's Open might prove to be quite a contest. Which reminds us that we have an old free flight job hanging from our chandelier, too. Oh, well, it probably wouldn't fly anyway—

* * *

Bob Palmer, one of the finest control line stunt flyers in the hobby, had the misfor-



"Mom and Pop" Robbers with some of their Oakland Cloud Dusters at All Western Open presentations

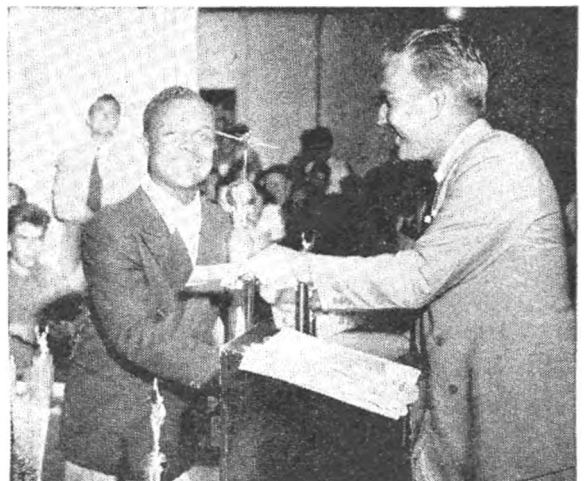

Frank Cummings receives trophy and \$300 check as Sweepstakes Open Winner at '47 Western Open. Tom Engelman, who is making the awards, was Director of this big event and is Chairman of L. A. Junior Chamber of Commerce Aviation Committee for 1948

West Coast Tips

(Continued from page 34)

tune of getting his hand caught in a die-stamping machine and lost four fingers from his right hand at the first joint. Bob is probably one of the best liked model builders on the Coast and we are sure that his friends and competitors alike extend their sincere sympathy at this tough break. While in the hospital, he was visited by J. C. Yates, Don Gulotta, Ed Tefft and many others one night, and though in great pain, Bob was figuring out how he was going to fly again when he got out. We have known Bob Palmer to be tops not only as a stunt flyer but also as a regular feller, and we predict he will never miss a lick as soon as his hand heals—because he's got what it takes!

We just received our annual report of the activities of the *Oakland Cloud Dusters*, that famed club of absolute experts who float around the clouds over San Francisco Bay. Believe us, with the kind of record they made as a group for 1947 they have a right to "dust off some clouds."

Among other highly rated doings, they managed to hang up 13 AMA records during the year; took 54 places in meets like the Western Open and the Nationals; and collected an awful lot of merchandise awards. When this group left for Oakland after the Western Open they needed nearly two cars and a truck just to pack away their prizes and merchandise (included was a motor scooter and some 40" trophies.)

We have a list in front of us that gives the club's complete record, but with apologies to "Mom" Robbers—"Mom, we just don't have enough space to print all of it"—we will give the names of the regular, associate, and candidate members:

REGULAR MEMBERS

David Acker	Lawrence E. Parsons
Manuel D. Andrade	Andrew G. Peterson
Robert E. Blau	Charles E. Pottol
Stanley Burns	Carl G. Rambo
Guy E. Dake	Donald J. Robbers
Michael G. Demos	Harvey S. Robbers, Jr.
Peter G. Demos	Harvey S. Robbers, Sr.
David W. Gilbert	James A. Robbers
Gordon F. Hansen	Myrtle B. Robbers
Donald B. Lausten	James F. Tangney
Sergius H. Milisch	Arthur R. Wells

ASSOCIATE MEMBERS

Stuart G. Bennett	Richard E. Schumacher
	Robert E. Moncrieff

CANDIDATE MEMBERS

George Matsumoto	Larry Mongeon
------------------	---------------

We have word that the *Burbank Club* is planning a contest for April 25, with a few new wrinkles thrown in concerning scale speed races. (We will try to have more information on this in our next issue.) The scale speed idea was first thought of nearly a year and a half ago, but so far this Burbank contest will be the first attempt to use it.

Incidentally, we noticed an ad recently where an *Atwood Champ* held the Class VI-A Sleeve Bearing racing class speed records. Almost a year ago we proposed this type of event; at the time it created quite a lot of favorable comment because it tended to cater to the younger modeler with the slimmer pocketbook. But few contest directors were courageous enough to attempt hold a contest, fearing there would be too few contestants.

We believe it would be possible to have separate classes of sleeve and ballbearing engine powered models. This would tend to level off the competition and permit more attendance at small meets, especially those where the 12 year olds and up could compete. We would appreciate comment on this idea, and perhaps if enough response is found it will be possible to carry the proposal before the AMA contest rules committee for a separate breakdown. What say you?

PHOTO CREDITS

Page		
2	Upper	British Combine
	Lower	Consolidated Vultee
15	All	Harold G. Martin
23	All	Robert C. Hare

Enjoy the Fun of Building These Popular SCIENTIFIC MODELS

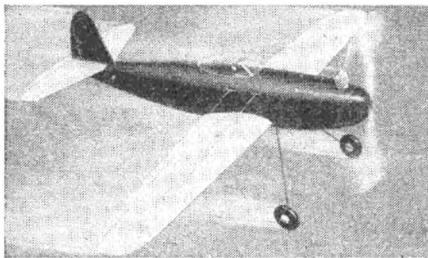

"CIRCLE KING", Wingspan 30", length 27". Flies on 24-foot lines of cotton thread. The Circle King is a rubber powered control-line model that is easily built from the complete kit which contains a double set of plans for a CO₂ or rubber powered airplane **\$1.00**

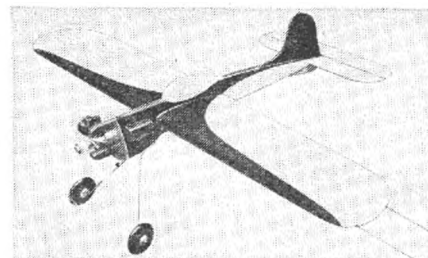

"STUNT ACE", Classes B-C, 40" Wingspan, length 27". The Stunt Ace is capable of performing every stunt in the book—flies inverted 6" off ground—vertical eights—horizontal eights—spectacles—inverted inside and outside loops and overhead eights. Kit is complete including rubber wheels **\$3.50**

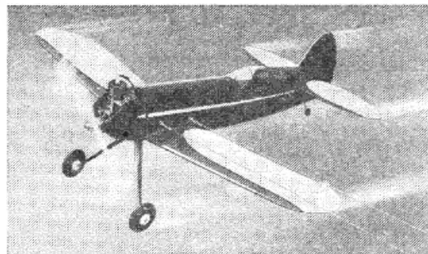

"CYCLONE", Classes A-B-C, Wingspan 36". Here's a proven champion as is evidenced by the hundreds of letters received from satisfied Cyclone owners. The Cyclone control-line model is excellent for stunt and training purposes. Kit is complete, containing every last detail right down to the smallest bolt and nut. **\$4.95**

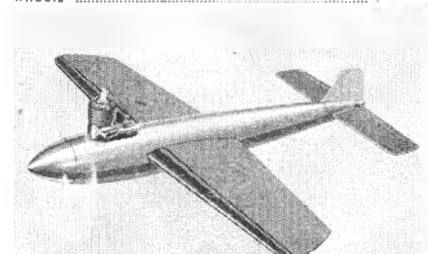

"TRAIL BLAZER", Classes A, B, C, 24" SPAN 6" CHORD. For the thrill of your life fly the Trail Blazer. Kit is most complete, comparing with models selling for twice the price. Finished balsa wood fuselage carved inside and out, metal bell crank, wire, full size detailed plans and simplified step-by-step instructions.

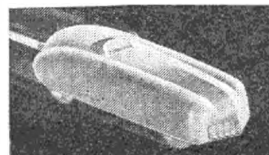

"NEW YORKER" Jet propelled, runs at high speed. Plastic body, metal bushed rubber wheels. **\$5.00**

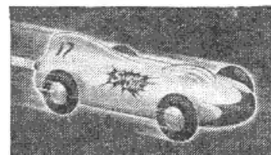

"SUPERJET" Capable of 100 M.P.H. speeds. Plastic body and canopy, metal bushed rubber wheels. **79c**



"ATOMIC" Class "B" control-line. Easy to fly! Easy to control! Rubber wheels and bell-crank **\$3.50**



"MERCURY JR" Class B free flight or control-line. Wingspan 50", length 36". Rubber wheels. **\$3.95**

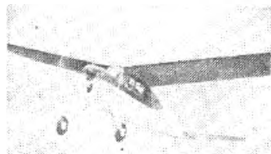

"GOOD NEWS" Class B free flight or control-line. Wingspan 50", length 36", rubber wheels. **\$3.95**



"HUMDINGER" Class B free flight or control-line. Wingspan 50", length 36", rubber wheels **\$3.95**



"MISS AMERICA" 40" Wingspan. A beautiful ship that is ideally suited to CO₂ power or rubber. **\$1.95**

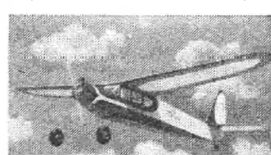

"FLEA" 36" Wingspan. The famous Fica model that has proven so popular. Fly it with the CO₂ engine or rubber **\$1.95**



"FIREFLY" 36" Wingspan. Another popular Scientific flier that is being flown with the little CO₂ engine or rubber. **\$1.95**



"MERCURY" Class C Wingspan 72", wing area 720 sq. in. Free flight kit, complete **\$5.50**
Control-line kit with 3/4" rubber wheels, bell-crank, hardware and many finished parts. **\$7.50**



"ZEPHYR" Large 42" Wingspan, a real honey! Kit very complete with 12" balsa propeller, wheels, metal parts, etc. **only \$1.00**



"SPARTAN" Large 42" Wingspan. Flies beautifully. Kit most complete with 12" propeller, wheels, metal parts **only \$1.00**

BUY FROM YOUR LOCAL DEALER AND SAVE 20c MAILING CHARGE

Scientific MODEL AIRPLANE COMPANY
218-220 N-4 MARKET ST., NEWARK, N. J.

DEALERS: YOUR JOBBER HAS THE COMPLETE "SCIENTIFIC" LINE! SEE HIM TODAY!

The Scale Model Supreme!

BE SURE TO BUILD IT

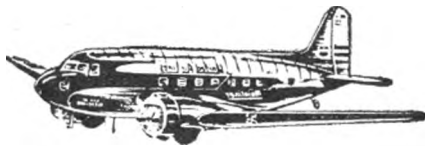

DOUGLAS DC-3 "Workhorse of the Air"

Span 70 3/4" Super-detailed. Almost like building the big plane itself. MFM Kit..... \$14.50
36" Model "IT" Dry Kit, \$1.00



28" Republic SEA-BEE MFM Kit..... \$3.00



30 3/4" Republic P-47 THUNDERBOLT MFM Kit..... \$4.00

LIGHTNING P-38 38 3/4" MFM Kit..... \$4.00
30" T Kit..... 1.50



Northrup P-61 BLACK WIDOW 49 1/4" MFM Kit..... \$14.50
36" T Kit..... 1.50

For the Really Serious Model Builders

46" Douglas HAVOC A-20 MFM Kit \$8.50
48 1/2" B-26 MARAUDER MFM Kit \$9.50
55" B-25 MITCHELL MFM Kit \$9.50



30" North American NAVION..... \$1.00



32" LANCER For CO-2 motors Dry Kit..... \$1.00

Tether TOPPERS

Topper I (CO-2) \$1.00
Topper II (A & B) 2.25
Topper III (B & C) 3.00



32" Baby FLEETSTER Designed especially for CO-2, but may be flown rubber. \$1.25



43" LUSCOMBE SILVAIRE Gas..... \$3.00
30" IT Kit..... 1.00



30" PIPER CUB Big favorite among all model builders. Dry Kit..... \$1.00



30" Beechcraft BONANZA Dry Kit..... \$1.00

STREAMLINER B or C. Builds either tractor or pusher..... \$4.00



De Luxe SHARPIE Greatly improved Kit..... \$2.00

Send for FREE Jumbo Folder

See your dealer first. If he is unable to supply you, accept no substitute, but order direct, enclosing 25c for packing and postage.

Cleveland Model & Supply Co.

World's Largest Manufacturers of Quality Model Aircraft Lines—Since 1919

4514D1 Lorain Ave., Cleveland 2, Ohio, U.S.A.

Latest RADIO CONTROL Developments and Official LICENSE Data!

by ED LORENZ

RECENTLY there has been considerable excitement over the new Citizens Radio Service band (460-470 megacycles) as a means of operating radio controlled models without a license. There are those, supposedly "in the know", who have received information from the FCC (Federal Communications Commission) and given it their own interpretation, and those who know nothing more about it than the announcement of a free band. We will try to clarify this matter and give you a complete picture of just what the situation is.

At a recent AMA-FCC meeting in Washington (attended by Dr. Walter Good, various manufacturers, members of the AMA and FCC, and the author) the frequencies and other rules and regulations were discussed and set up. This article deals primarily with what took place there and has been approved by the FCC and AMA as being correct and authentic in every way.

First of all, it must be remembered that the FCC and not the AMA is the governing body as far as radio transmissions are concerned, and it therefore makes all rules and regulations covering the use of a radio

transmitter. The AMA may and does act as intermediary between the FCC and the model builder in making the rules covering the flying of radio controlled models. At present the FCC requires that each and every person operating a radio transmitter must have the proper license to cover such operation. There are no exceptions to this rule. Then what can the model builder do to fly his radio controlled model? He can obtain a "ham" license (write to the A.R. R.L. in West Hartford, Conn. for information, or get in touch with a local ham), or he can wait until the so-called "license free" bands are opened for public use. We said so-called "license free" bands because there will be a simple license required, but probably nothing more than filling out a card and filing it with the FCC. No technical knowledge or code will be required.

It must be pointed out here that no individual will be allowed to construct his own transmitter for operation in the allotted bands of 27.230-27.280 megacycles and 462-468 megacycles. Manufacturers will be required to take out special licenses to experiment on these frequencies and will have to

FRENCH "MAURICE FARMAN" RECONNAISSANCE BIPLANE OF 1914. POWERED BY A RENAULT ENGINE OF 70 H.P. IT HAD A HIGH SPEED OF 62 M.P.H.

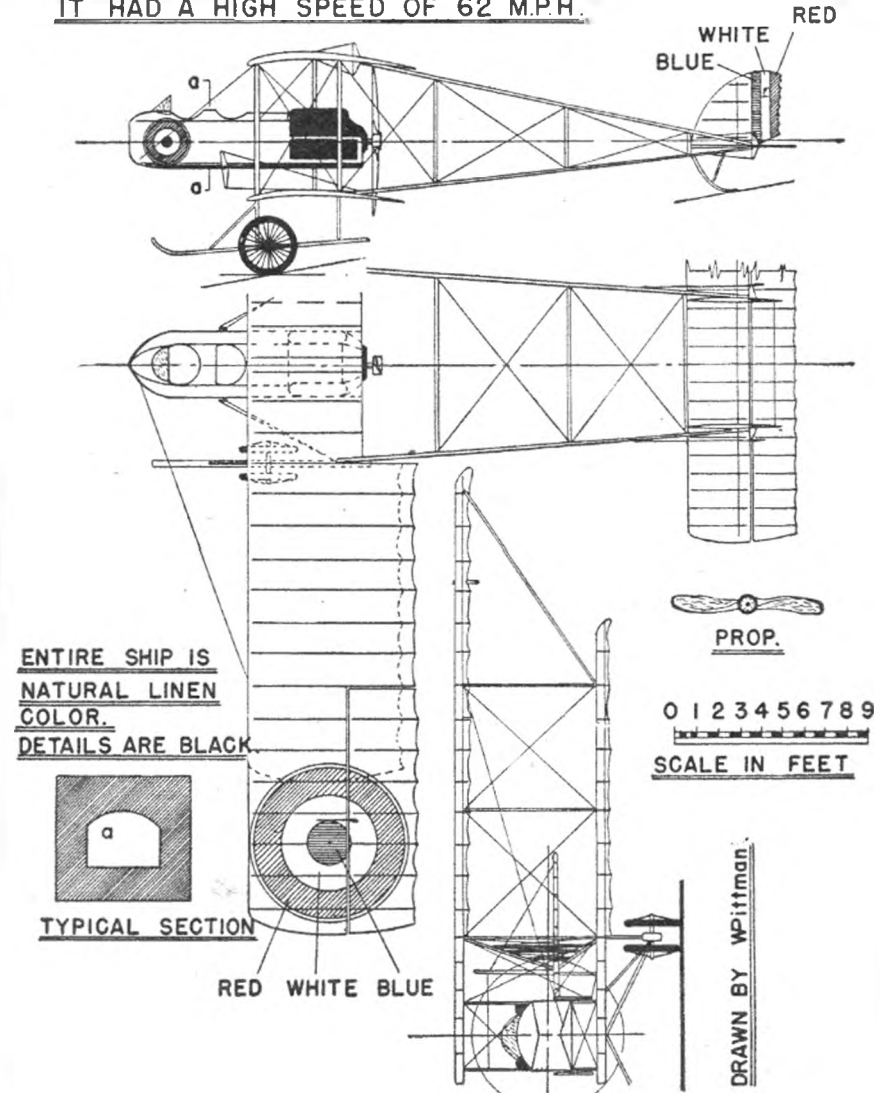

PROOF of MORE OPPORTUNITY for you than ever before in Aeronautical Engineering

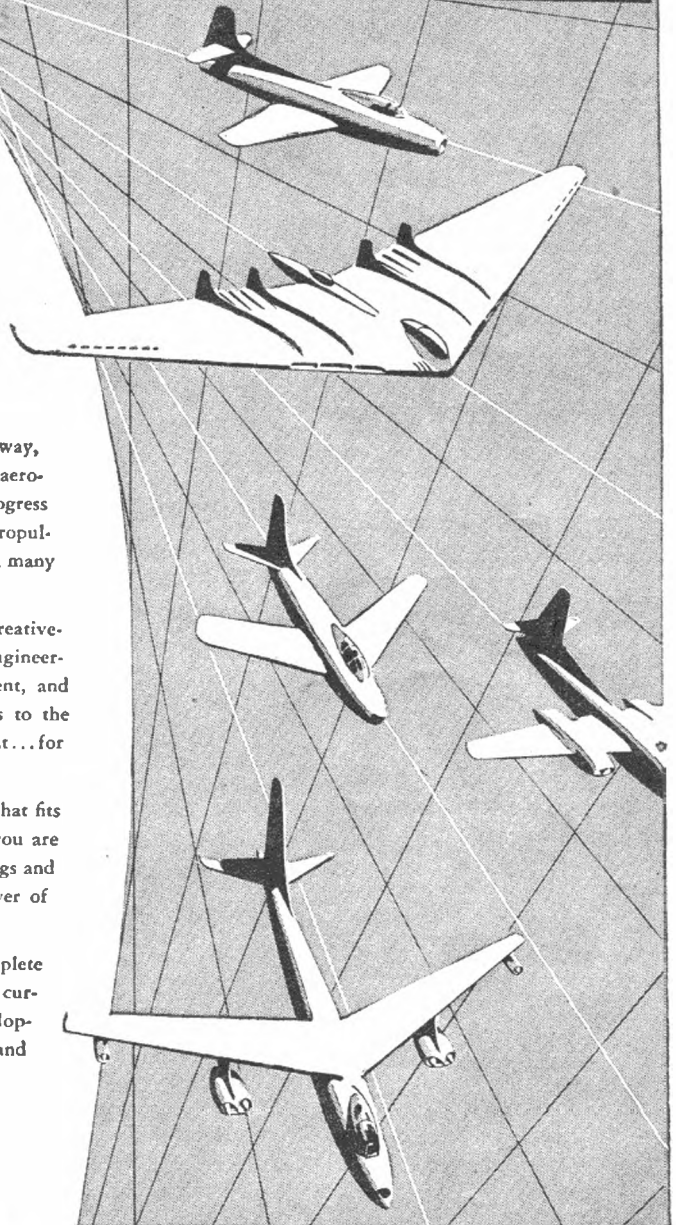
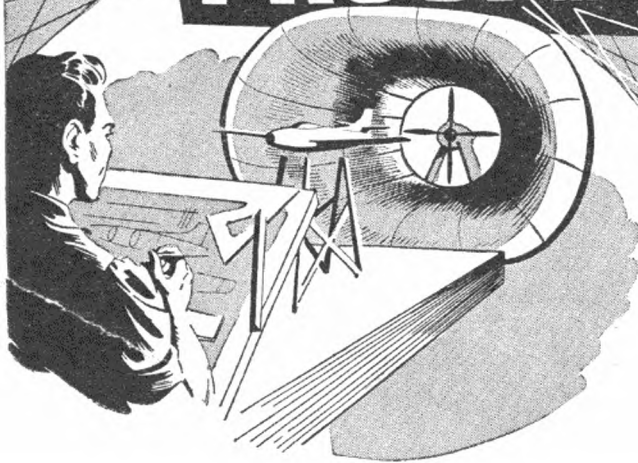

Right now there are more aeronautical engineering projects under way, and scheduled for the future, than ever before. Opportunities for the aeronautical engineer grow greater, grow broader, day by day. Spectacular progress in aviation is being ushered in by Flying Wing design, jet and rocket propulsion, gas-turbine engines, sonic and super-sonic speeds, atomic power, and many other still-secret developments.

All this means more opportunity than ever before for YOU. Creative-minded, or practical-minded, there is a place for you in Aeronautical Engineering, with its many types of duties... in design, research, development, and production. The door is wide open for making original contributions to the progress of Aviation... for reaching the heights of personal achievement... for gaining security and success.

Prepare yourself to grasp these enviable rewards... with training that fits you to meet the industry's needs. At Northrop Aeronautical Institute you are trained by a division of the organization that developed the Flying Wings and other famous aircraft... an organization that is itself a major employer of engineers and knows *how* and *what* you must learn.

In only 2 years (in less time, with advanced standing), you can complete the Northrop Aeronautical Engineering course... a technical institute curriculum accredited by the Engineers' Council for Professional Development. Find out how this Northrop course gives you both a better start and an earlier start on your career. Send coupon for full details.

N.A.I. also offers a 1-year Aircraft and Engine Mechanics course approved by the Civil Aeronautics Administration.

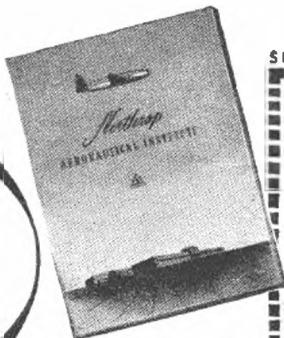

SEND COUPON FOR CATALOG AND COMPLETE INFORMATION

NORTHROP AERONAUTICAL INSTITUTE
1507 East Broadway, Hawthorne, Los Angeles County, California

Please send me the Institute catalog and complete information, including starting dates of classes. I am interested in

- Aeronautical Engineering
 Aircraft and Aircraft Engine Mechanics (A & E)

Name _____

Address _____ Age _____

City _____ Zone _____ State _____

Check one: Veteran In Service Civilian

APPROVED FOR VETERANS

**You Can Build
TRIM, STURDY
MODELS**

Model
Ships

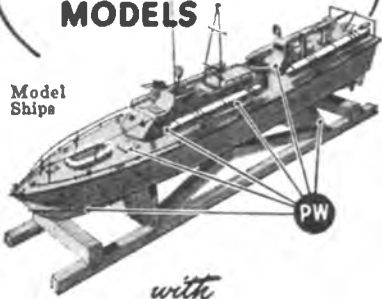

with

PLASTIC WOOD

PLASTIC WOOD molds right into the lines of your model. Won't chip, crack or split! Handles like putty... hardens into wood. Can be carved, sawed and sanded. Ready to use. Takes dope or paint.

YOU'LL WANT Plastic Wood Solvent, too! Makes a perfect filler when mixed with Plastic Wood. Solvent removes Plastic Wood from tools and hands. Solvent is also used as a dope thinner!

FREE BOOKLET ...

"Slick New Tricks for Building Better Model Planes." Ask your local model dealer or write Boyle-Midway Inc., 22 E. 40th St., New York 16, N. Y.



Swell for patching broken balsal Tube or Can



T.M. REG. U.S. PAT. OFF.

PLASTIC WOOD
A CELLULOSE FIBRE FILLER

MOD-KRAFF has the LEADING LINES.....



Write for Prices and Discounts on Your Letterhead. No Retail Mail Orders Accepted.

MOD KRAFF Co

840 Union St., New Orleans 12, La.

GERMAN HALBERSTADT CL-2 OF 1917

THIS TWO SEATER WAS PRODUCED BY THE HALBERSTADTER FLUGZEUGWERKE AT 10,000 FEET IT MADE 97 MPH. POWER WAS FURNISHED BY A 180 H.P. MERCEDES

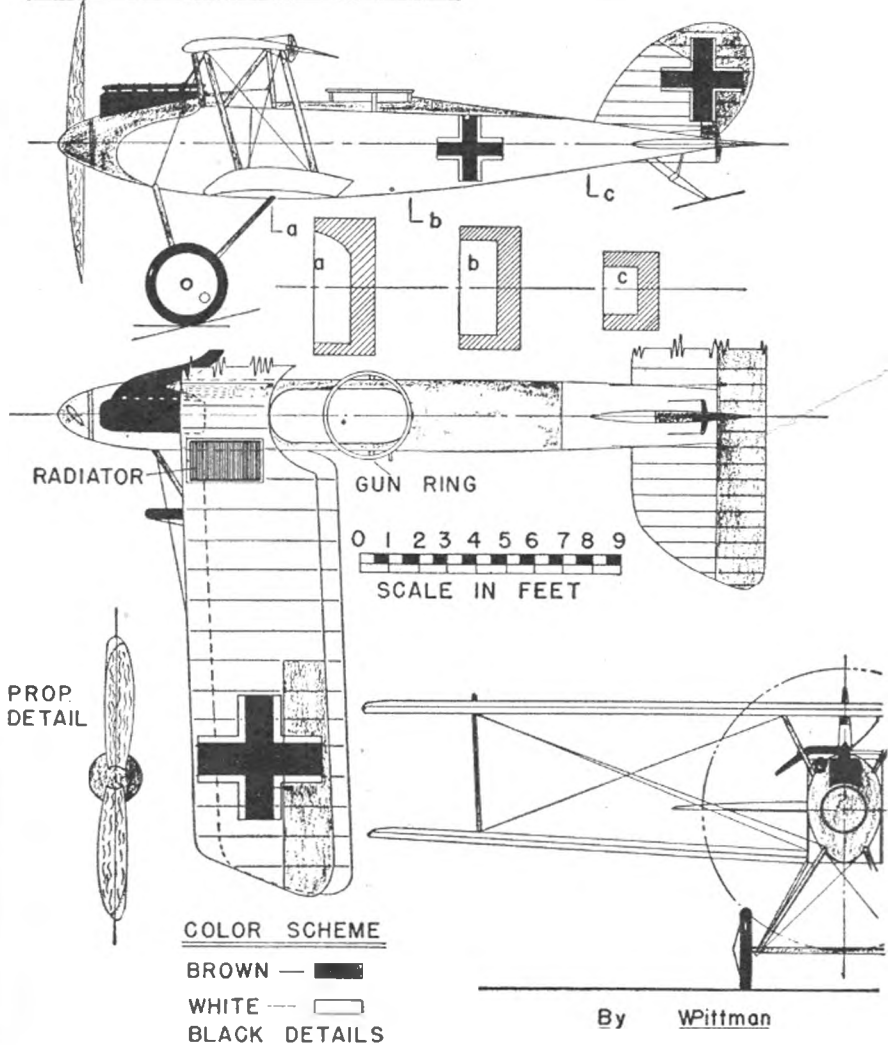

have the units approved by the FCC before they are put on the market. Please note that while these frequencies are near the present ham bands, no ham will be allowed to operate within the bands unless he has obtained the proper license. If you are a ham, or have a ham friend and desire to experiment on the amateur frequencies of 28,500-29,700 megacycles and 420-450 megacycles to perfect receiver design, it would be a simple matter to change to the radio control frequencies when transmitters are available. In any case, the individual will not be allowed to change the frequency of the purchased transmitter in any way. This means that the receiver must be built with a variable frequency control of some sort. The transmitters will probably be sealed at the factory and only battery changes will be permitted. It is thought, at present, that even the changing of a tube will not be left to the purchaser since this may be enough to put the transmitter off frequency.

This is especially true of the 462-468 mc band, where length of tube leads and other wires definitely affect the frequency of the unit. Repairs or tube changes on transmitters in the 27,230-27,280 mc band probably will be allowed by persons holding a 2nd or 1st class commercial radio license. Repairs and tube changes in the 462-468 mc band most likely will have to be made by the manufacturer of the unit. The individual may make his own receiver and control mechanism, but due to the close frequency tolerances on the low band and the difficulty in working with U. H. F. (300-3000

mc) the model builder probably will have to purchase the receiver and transmitter in one complete set. For those qualified to use the necessary amateur frequencies for experimenting, it is well to remember that the power requirements on transmitters for the radio control bands are 5 watts input to the final stage on the 27,255 mc (center frequency) band and 10 watts input to the final stage on the 465 mc (center frequency) band. This will eliminate the use of some of the 25 to 100 watt transmitters which are being used for radio control at the present time.

Although these two new bands have been approved by the FCC for experimental work, there are so far as is known no manufacturers ready to submit their equipment for approval. When such units do reach the market it is believed that they will be bulkier, heavier and more expensive than present commercial equipment, and the latter thus appears to be the only equipment that will be available for quite some time.

The receivers, since they must be carried by the plane, are our chief worry as far as size and weight is concerned, and will undoubtedly be 1 to 4 ounces heavier, per channel, and a bit larger. Power requirements should remain the same. The cost will be higher due to the extensive research and engineering needed, especially in the 465 mc range, but should drop almost immediately due to the expected high volume of sales.

Here are a few suggestions to go on when designing your own receiver. Due to the

mite .099

compression-ignition engine

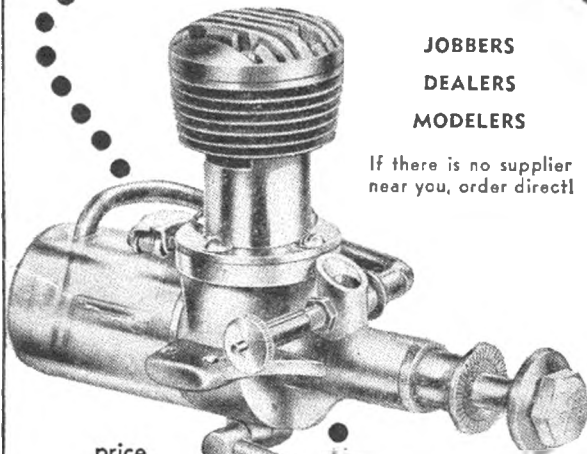

JOBBER
DEALERS
MODELERS

If there is no supplier
near you, order direct!

price
12.50

- ~~NO SPARK PLUG~~ . . . save 1/2 oz.
 - ~~NO COIL~~ save 1 3/4 oz.
 - ~~NO CONDENSER~~ . . . save 1/2 oz.
 - ~~NO BATTERIES~~ . . . save 2 oz.
 - ~~NO LEAD~~ save 1/4 oz.
- total saving in wt.—5 oz.

a new national open record—67.6 m.p.h.—class "1" control line!

- finest in **diesels!**
- highest power to weight ratio ever developed.
- positive engine cutoff—efficient throttling for test purposes—runs steadily at the throttled down speed of 1500 r.p.m. eliminating critical dip and adding seconds and minutes to free-flight time!
- exhaustive engineering tests for .13 months guarantees the finest in precision engines!
- for the new postwar flying thrill get your **mite .099** at your dealer now!

● **performance:**

1st pennsylvania open—class "1."
fixed compression ratio—13½ to one.
12 min. on 18 sec. run—best endurance time,
stunt biplane looped on 50 ft.—.014 dia lines.
power output—9000 r.p.m. (8" dia.—6" pitch prop).

● **specifications:**

class—"A."
bore and stroke—.500.
displacement—.099.
overall height—2¾ inches.
weight including tank—2¼ oz.
dual exhaust.

mite distributing co.

257 Water Street, Brooklyn 1, N. Y., Dept. MAN-3

Mart-Lee MUFFLER

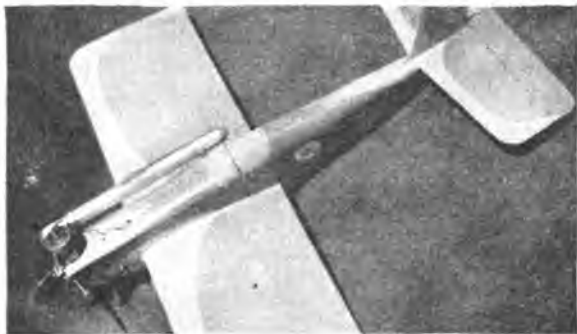

REDUCES ROAR TO A POWERFUL HUM



YOU CAN HEAR THE TIRES SCREECH
CUSTOM-BUILT MUFFLERS MADE UPON SPECIAL ORDER
COPYRIGHT 1948 BY MART-LEE MFG. CO.

For Model Airplanes, Cars and Boats

Neighbors, nationwide, voice their approval. Operate your models where and when you want too.

REDUCE EXHAUST ROAR and GAIN R. P. Ms.

Beautify your model and silence complaints

For Class "C" and "D"
engines having exhaust manifolds.

Weight 3 ounces
—diameter 1 inch
—length 1 3/4 inches

\$375

For Class "A" and "B"
engines having exhaust manifolds.

Mart-Lee Junior
is only 5 inches
long and weighs
1 ounce.

\$295

**If your dealer cannot supply you, order direct—
add 25c for postage.**

DEALERS & JOBBERS write for information
ORDERS SHIPPED IN ORDER OF RECEIPT

MART-LEE MFG. CO.

1331 North Meyers St.

Burbank, California

PATENTS PENDING

ULTRA-MODERN BEE-LINE JETS

THE TINY NEW SUPER FAST CO₂ PROPELLED RACING MODELS

Thrilling Speed - Long Range Flights
The Tiny New BEE-LINE JETS Whiz Through The Air On A Fine Steel Guide Line At Astounding Speeds Up To 125 M.P.H. For Distances Up To 1000 Ft.

SUPER SONIC STREAK

Fast As Lightning

Slick As A Whistle

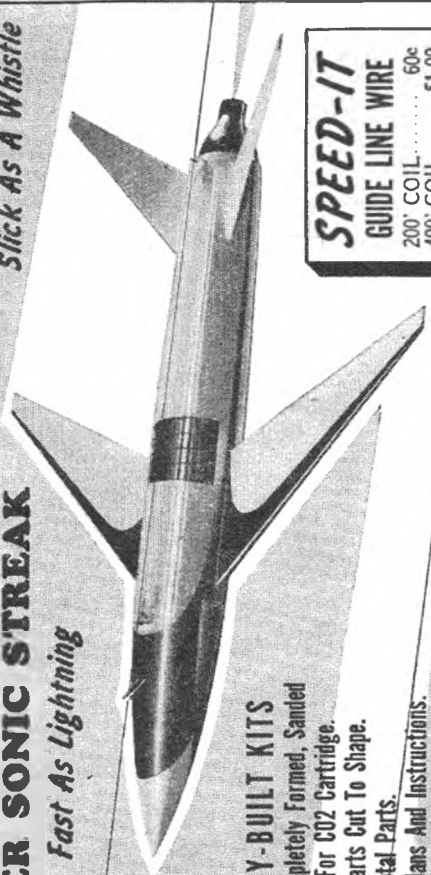

FLASH ROCKET

Thrilling As A Trip To The Moon

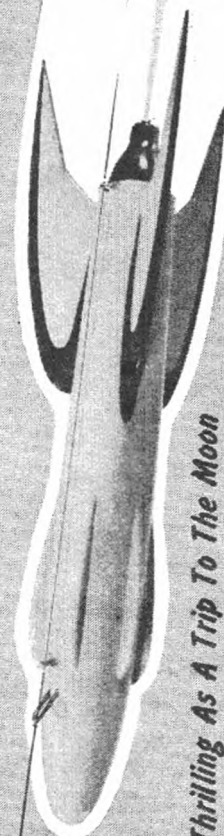

- NEW JIFFY-BUILT KITS**
- ★ Bodies Completely Formed, Sanded And Bored For CO₂ Cartridge.
 - ★ All Other Parts Cut To Shape.
 - ★ Finished Metal Parts.
 - ★ Complete Plans And Instructions.
- Kits Only 75c Each**

SPEED-IT	
GUIDE LINE WIRE	
200' COIL	60c
400' COIL	\$1.00
600' COIL	\$1.40

VICTOR STANZEL & COMPANY
9444 Ave. Central, Dune, Dipping
SCHULENBURG, TEXAS

ANOTHER STANZEL FIRST

narrow width of the low frequency band—50 kc compared to the present 6 meter band of 4 mc—a very selective circuit will have to be used to confine the selectivity of the receiver to the transmitting frequency of about 27.255 mc. Present superregenerative receivers tune quite broadly and therefore would probably be of little use. An R. F. amplifier, crystal circuit or superhet circuit most likely will be used. For the high band, a superhet circuit appears to be the best bet. This is due to the fact that there are very few tubes available for this high frequency, which would be suitable for model use, and amplifiers or mixer circuits would have to be used. It should be pointed out here that present equipment cannot be changed over to the high band. It may, however, be converted to the low band without too much trouble.

Control mechanisms will probably remain the same for quite some time. New versions will appear but complicated means of control will still be a thing for the future. Jet propelled, multi-engined craft and models with *everything* operating by R.C. are nice to dream about, but it would be far better to wait until this new phase of model building progresses a little more. Control line models didn't loop-the-loop or hit 140 mph a week, a month or even a year after they were introduced. The model builder would do well to concentrate on the design of a stable airplane and the mechanical means of actuating the controls, or we should say *control*. It has been proven time and time again, by experts, that rudder control will accomplish more than a plane load of radio equipment.

The Good brothers have won many contests with rudder control alone. The exception to a simple single control is Jim Walker's marvelous multi-channel proportional control plane. But all this will come in time and some day we may hold miniature National Air Races, with radio controlled models performing all the feats of the larger planes.

In closing, remember this: keep your equipment as simple as possible; keep it neat and don't try to overpower your plane or expect too much from your first radio job.

(We expect soon to publish complete data on receivers suitable for the two new bands. Transmitters, however, will be covered briefly if at all since homemade transmitters will not be allowed in these bands, and furthermore the bands are not yet "open".—EDITOR)

Modeling in Flying Schools

(Continued from page 21)

"We do consider model experiments, building, and flight most valuable in the development of air interest and air knowledge," continues Hammond. "However, there seems to be a failure to connect up the performance and understanding of the model with the aerodynamics, engineering, and understanding of full flight. Model work seems to consist of an element of interest limited to satisfaction at the observance of the phenomenon of flight; whereas, full scale work carries an interest based on understanding. Flight may be necessary as proof, but many an aerodynamicist or engineer has never flown or even been in the air.

"My thought is that a greater interest should be developed on the part of model workers to understand the why and the wherefore of what they are doing, to convert the results of performance into cause and effect."

While Mr. Hammond's comments are the exception, rather than the rule, and as such may sound arbitrary to many builders, it should be pointed out that his thoughts are constructive. There is some truth in what he says but, on the other hand, a great many builders do already appreciate cause and effect.

GOTHAM'S EX-G.I.'s GIVE YOU MORE FOR YOUR MONEY

- ★ FREE POSTAGE
- ★ FREE PACKING
- ★ IMMEDIATE SHIPMENT
- ★ MONEY BACK GUARANTEE
- ★ WE HANDLE EVERYTHING

REMEMBER

Gotham's ex-G.I.'s carry everything.

CHECK

this list of hard-to-get items:

- ★ Fox 59.....\$29.95
- ★ Wasp-Twin 29.95
- ★ Forster 29.....red. to 14.50
- ★ Forster 99..... 24.75
- ★ McCoy Sportsman Jr..... 14.95
- ★ McCoy Sportsman Sr..... 16.95
- ★ Pacemaker C..... 12.50
- ★ Ohlsson 23.....red. to 9.95



OHLSSON "23" \$9.95

- ★ OK Twin\$55.00
- ★ Madewell C..... 12.50
- ★ Dyna Jet 24.50
- ★ Drone B.....red. to 14.95
- ★ DEEZIL "A" 12.95

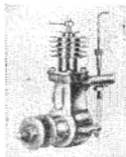

DEEZIL "A" \$12.95

- ★ McCoy Hot Rod Race Car.....\$42.50
- ★ Dooling Race Car..... 45.00
- ★ Reuhl Race Car..... 24.95
- ★ Thimble Drone Racer..... 3.95
- ★ Marlin Boat..... 8.50
- ★ Reuhl Bakelite Hydro..... 15.00
- ★ Formacraft 12.50
- ★ Jr. Whirlwind..... 2.95
- ★ Zing 4.95
- ★ Modelcraft Bi-Line..... 4.50
- ★ Cleveland Streamliner..... 4.00

FREE A coil and condenser with each gas engine. A 176 page book on model engines with each order of \$5.00 or more.

HOW TO ORDER

It's simple—because you don't pay for packing, postage or any other "charges." Just write down what you want and the price and send a money order or check, or send only \$1.00 and we ship C.O.D. for balance. It's easy! It's quick! Minimum order—\$1.00. Write Dept. M.

GOTHAM HOBBY CO.

107 E. 126th Street
New York 35, N. Y.

Airways

(Continued from page 31)

continue control line flying through the winter, whereas in previous years they practically went into hibernation when cold weather set in.

In addition to a regular job, Joe is Publicity Chairman for *The Sky Blazers*, and on the side writes a regular model plane column each Sunday in the Atlantic City Press. Although these columns are usually devoted to a discussion of various model types, a recent one was made up of excerpts from letters received from foreign modelers—Joe made contact with these new acquaintances through names published in the *News of Modelers* department of MODEL AIRPLANE NEWS.

LOST OR DAMAGED ENGINES are not a great worry to members of the Galesburg Model Airplane Club of Illinois. Secy. Kenneth Freese noted the suggestion on this subject in "Air Ways" of Jan. 1948 M.A.N. but feels his club has this difficulty well in hand. Voluntary contributions from members are put in a fund used solely to reimburse members for losses. Of course there are a few strings attached to this form of "insurance". Free flight ships must have reliable dethermalizers, and witnesses must certify that the equipment worked if a ship is lost; if so certified the owner gets half the price of a new motor. Should a lost ship be returned, the money collected is returned to the fund, or the modeler can put his replacement motor up for auction and retain any amount of money greater than he received from the fund.

In the event of motor damage to a control line ship, a board of club officers checks on the amount of damage and the owner is awarded the sum they decide upon to half the value of the engine. Needless to say, only those members who contribute to the fund are eligible for any of these benefits.

This progressive club has a low cost insurance coverage giving full protection in case of injury, death or property damage. Because of stress on safe flying they have never had occasion to make a claim.

Freese and Ray Johansen have over 250 Kodachrome slides taken of club activities; the slides are very popular at banquets, parties and are loaned to other nearby clubs.

Aside from feverish activity readying ships for flying under the new rules, the chief ambition of the Galesburg group is to form an association of model clubs in Western Illinois and Eastern Iowa for the purpose of coordinating contest and other model activities. They hope to hear from other clubs south to Quincy and Decatur, Ill.; west to Ottumwa, Iowa; north to Rockford, Ill.; and east to Bloomington. They will be pleased to coordinate ideas from the 30 or so other model plane groups within this area.

Picture No. 1 is a model *Convair 240* built by Frank P. Hernandez Jr. (2120 Burroughs St., San Diego, Calif.). The model has 50" wingspan, weighs 4 lbs. 14 oz. and is powered with two *Madewell 49's*. The interior is completely furnished with seats, rugs, hostess room, radio room, galley, lavatory and baggage compartment. There are lights in the cabin, wing-tips, tail and nose. To complete this fully equipped plane, Mr. Hernandez has even included a shock absorbing landing gear and a retracting stairway for entrance and exit of passengers. It took 485 hrs. to build at a cost of \$75.

Brian Fairey (110 Widney Road, Bentley Heath, Knowle, N. Birmingham, Eng-

land) contributed No. 2. The three men in this photo are shown at the first Midland Rally at Warsaw Aerodrome last June. Mr. Fairey is holding a *Trojan* powered *Cavir*; Brian Eccles and Martin Ollis with a *Lepricorn* sailplane of the latter's own design. All are members of the *Dorridge Model Aero Club*.

Oldtime plane fans should be interested in No. 3 submitted by Joe F. Park (830 N. 3 Ave., Tucson, Ariz.). This well posed model of the ancient *Bleriot Monoplane* is not only extremely realistic but it is a reasonably good flier as well. Close examination will show a rubber hook at the rear end of the fuselage. Mr. Park has had many nice flights from this ancient looking ship.

John E. Burkam (820 Wayne Ave., Dayton, Ohio) contributed the gas powered model helicopter, No. 4. This model was constructed as the basis of Mr. Burkam's thesis for a master's degree at the University of Cincinnati. He is trying to solve the problem of inherent stability for the model in hopes that the solution can be applied to full scale helicopters. The model has a rotor diameter of 7 ft. and is powered by a pre-war *Forster Super 99* with throttle. Gross weight is 7.8 lbs. and maximum lift of the main rotor is 12-1/2 lbs. Bolted on the engine crankshaft is a centrifugal blower which cools the engine, acts as a flywheel, and gives a convenient method of starting the engine by means of a leather thong. The drive shaft from nose to tail runs at half engine speed, as does the tail rotor. Main rotor revolves 1/4 as fast as the drive shaft. All shafts are carried in ball bearings. A ratchet in the main rotor hub provides for free wheeling and auto-rotation if the engine stops before the model reaches the ground. The main rotor hub consists essentially of two adjustable pins on which the blades are hinged with the axis of the pin at a 45° angle to the blade's longitudinal axis. When the blades rise, as they do if the engine is stopped in flight, the blade angle decreases, making auto-rotation possible.

Four flights have been made close to the ground under the restraint of strings. The throttle was linked to a small reversible electric motor and fine wires strung from helicopter to operator, who could thus open or close the throttle any amount by working a double-pole-double throw switch.

No. 5 is a *Republic Seabee* built by Robert C. Mikesh (306 Oakwood Ave., Ottumwa, Iowa) from a 3 View drawing in MODEL AIRPLANE NEWS. The model is made from white pine to a scale of 3/4" = 1'. Being hollow it has a molded plexiglas enclosure which was formed in the oven; it also has a retractable landing gear. Ribbing along the wings and tail are made from string doped to the surfaces. A local dealer purchased Mr. Mikesh's *Seabee* for demonstration purposes.

John M. Olson (302-1/2 W. 3 St., Hastings, Minn.) sent in No. 6 which is a *Cub Coupe*. He claims this is a sturdy little ship, having been cartwheeled across a quarter block of stubble field one windy day without receiving any damage. It is powered by a *Dieselized Arden .099*, weighs 10 oz. and is red with gray numerals. Mr. Olson's ambition is to eventually install Radio Control in the ship.

The *Siemens-Schuckert D4* shown in No. 7 is another WW I job for enthusiasts of that aviation era. Dan Weinberg (2035 72d St., Brooklyn 4, N.Y.) carved the body from block balsa with built up

wings. He incorporated regular ignition when the plane was first built, but recently has been using glo-plug ignition. Coloring of the ship is a green body with red and white checkerboard wings. Mr. Weinberg says she flies like a bird on 35 ft. lines and he has complete control of it from takeoff till landing; he now has made over 100 flights.

W. Van Rensburg (P. O. Goedegun, Swaziland, So. Africa) submitted No. 8 which was built from Dick Clarke's *Whippersnapper* published in Jan. 1945 M.A.N. Mr. Rensburg's daughter, Jacqueline, seems to be an enthusiastic observer. The plane is all balsa with a very high gloss finish.

The jet powered U controlled plane viewed in No. 9 was sent in by Lawrence Gostomski (Rte. 1, Thorp, Wisc.). The plane is all wood and was built to test Mr. Gostomski's cooling system which he developed—he found it worked quite well. The plane is a very good performer.

Thomas Gabriel (193-07 Linden Blvd. St. Albans 12, N.Y.C.) contributed No. 10, a modified version of the *Jabberwock*. Powered by 12 strands of T56 rubber it has made several flights of long duration.

No. 11 is a *Korda Wakefield* winner constructed by Alfred Walsky (Box 30, Morris Plains, N.J.). Span is 44" and weight 9 oz.

No. 12 was submitted by G. van der Linden (The Hague, Regentesselaan 73, Holland). The model is named *Ria* and has made many good flights in several contests. The span is 8' 4".

NEWS OF MODELERS

J. T. Polding (2 Samuel Sq., Gawker Rd, Barnsley, Yorks, Eng.) would like an American pen pal about 16 yrs. old who is interested in free flight gas jobs, rubber models and gliders.

D. W. Evans (1 Oxford St., Weston—S—Mare, Somerset, Eng.) is anxious to exchange engines with an American modeler.

Jim Inkester (216 Wallasey Rd., Wallasey, Cheshire, Eng.) would like to correspond, exchange plans, etc., with any chap 19-20 yrs. old who is interested chiefly in free flight power jobs. He is particularly eager to obtain plans of the *Jersey Javelin* which he is unable to get in his country. If successful he intends to power it with a 2cc Majesco Diesel, which is a fairly large Class A job with very good performance when turning over a 12" prop.

Capt. H. M. Bourgeois (VMF-323, MAG-33, MCAS El Toro, Santa Ana, Calif.) is interested in contacting a model builder in England. He would like to exchange letters, magazines and model equipment. Capt. Bourgeois, 27 yrs. old, has been building models of all types since 1929 but he is particularly interested in gas, control and free flight. His present occupation is fighter pilot in the U. S. Marines. He is also interested in model race cars.

William R. Sinclair (828 W. "E" St., Wilmington, Calif.) would like to trade three view plans of World War I aircraft with anyone interested in this subject.

P. R. Darrington (14 Rowland Road, Barnsley, Yorks, Eng.) wishes to correspond with an American modeller about 17 yrs. old. He is primarily interested in free flight power, rubber, and glider—"anything but control line."

C. J. Burger (Borneostraat 13, Haarlem, Holland) is unable to buy a small model engine in his country and would like to contact an American who would be interested in helping him obtain one.

John W. Stafford (5a Goldsmith St.,

NOW MORE THAN EVER

A BARGAIN IN QUALITY

FORSTER "29"

HIGH PERFORMANCE

★ NEW LOW PRICE!

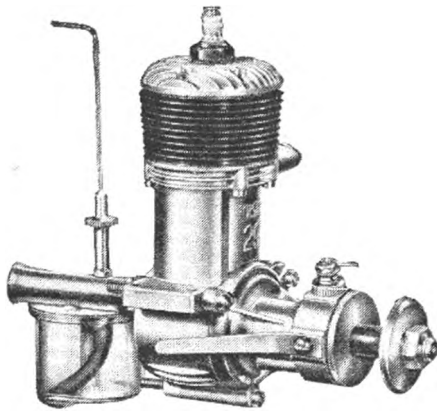

**THE SAME BALL BEARING ENGINE!
THE SAME HIGH QUALITY!
THE SAME SPEED AND POWER!
Everything is the same except the
NEW LOW PRICE!**

Here you get a quality "double-duty" engine complete with metal fuel tank and timer for spark ignition operation, which, however, operates equally well with the new glow-plug. Nothing but a change of plugs is necessary to give you top performance in both fields.

See it at your dealer's!

Write us for literature showing comparative power curves of actual power developed with spark plug and glow-plug ignition, using gasoline, alcohol and glow-plug fuel.

ONLY **\$14⁸⁵** LESS C.&C.

FORSTER BROTHERS

3539 N. Kenton Ave., Chicago 41, Ill.

Look what 50c buys in beautiful Modelcraft kits

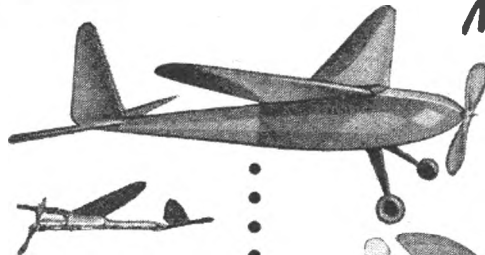

KAYDET

Only 5 joints to glue. 25 to 30 min. assembly and you have this all-balsa die-cut stick model in the air. Slotted cabane. Grooved top. **15¢** plus 5c postage



GREMLIN

You can easily build this sweet little 15" glider in 20 to 30 min. Balsa, semi-finished. **15¢** plus 5c postage

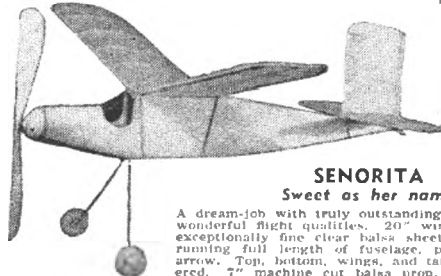

SENIORITA
Sweet as her name

A dream-job with truly outstanding appearance and wonderful flight qualities. 20" wingspan. Kit has exceptionally fine clear balsa sheets. 1/20" thick, running full length of fuselage, printed with red arrow. Top, bottom, wings, and tail are paper-covered. 7" machine cut balsa prop. Prop hooks, hardwood nose plugs 1 1/4", hard-wood wheels. **50¢** plus 15c postage



PACIFIC ACE

(The Master)

IF DEALER CANNOT SUPPLY,
ORDER DIRECT

Modelcraft
"Flying Models That Really Fly"
11929 South Western Ave. Los Angeles 44, Calif.

Giant 30" wingspan. Over 1,000,000 of this outstanding rubber-powered fier have been sold to satisfied modelers. The same fine kit is now in production with all-balsa parts, and full-size plans. Pacific Ace has flight performance comparable to many a \$2.00 model. No longer on or wing splicing necessary —full length wood. Less liquids. **50¢** plus 15c postage

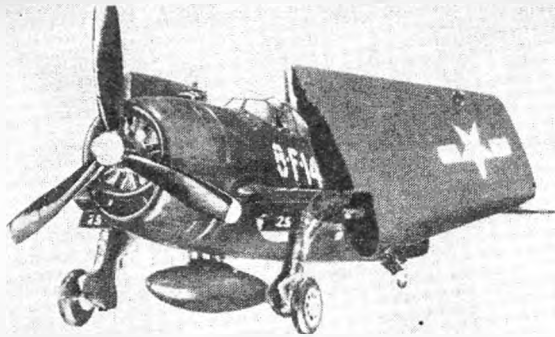

F6F
U. S. Navy Fighter
\$2.75

DYNA-MODEL DOES IT AGAIN !

No one—yes, No one else except Dyna-Model makes such accurately detailed 1/4" scale solid model kits—even to folding wings—such as the pictured Grumman "Hellcat" with its carved fuselage and 23 authentic superbly finished parts, including propeller, engine and duct, cockpit details, landing gear, bubble canopy and armament \$2.75.

Other exciting "Dyna-Mo" kits which give the model builder the chance to give his model that professional touch are:

- P51 "MUSTANG"—23 FINISHED PARTS, CARVED FUSELAGE\$2.75
- P38 "LIGHTNING"—49 FINISHED PARTS, CARVED FUSELAGE 3.50
- F8F "BEARCAT"—15 FINISHED PARTS, FOLDING WINGS 2.75
- P47 "THUNDERBOLT"—43 FINISHED PARTS, PLASTIC WING TIP LIGHTS 2.95

All kits have templates, figs, decals and engineered drawings.

Ask your dealer for "Dyna-Mo." If he cannot supply you write us direct enclosing check or money order plus 25c for packing and postage—no C.O.D.'s.

Model R.R. fans—see our ad in Model Railroader for outstanding "HO-00-0" accessories.

DYNA-MODEL PRODUCTS COMPANY
76 SOUTH STREET, OYSTER BAY, NEW YORK

CHICAGO'S
OLDEST NATIONWIDE
DISTRIBUTOR
is well qualified to serve you!
19 YEARS EXPERIENCE

- Planes
- Ships
- Race Cars
- Railroads

Just use **MODEL AIRPLANE NEWS** as your catalog
COMPLETE STOCK Engines Parts Supplies
TROST
Model Airplanes and Hobbies
3111 W. 63rd St., Chicago, Ill.
DEALERS: WRITE PHONE or WIRE
WHOLESALE ONLY

THE NEW SUPER FUELS
ARDEN GLO-FLITE*

*REG. TRADE MARK

—ULTRA SPEEDS—EASY STARTING—
THE ONLY FUEL RECOMMENDED BY RAY ARDEN OF MICRO-BILT INCORPORATED FOR USE WITH THE NEW SENSATIONAL ARDEN GLOW-PLUG—

As manufacturers of the First Glow-Plug Fuel we have purposely refrained from advertising until we could supply the country's leading jobbers and dealers. Many thousands of cans have already been shipped and we are now in position to supply the ever increasing demand.

The **ARDEN GLO-FLITE** you can buy today is identical with the fuel used last summer in establishing several national records—tested & proven—there may be imitations but there is no substitute—performance counts.

No. 1 \$1.00 Per CAN
METHANOL BASE

CHEM-L-CO INDUSTRIES
WYOMING, PENNA.

No. 2 75 CENTS Per CAN
GAS BASE

Mansfield, Nottinghamshire, Eng.) is interested in corresponding with an American boy. His interests are in all kinds of modelling, from solids to rubber models, gliders, control line and free flight power jobs.

CLUB NEWS

California

Fresno Gas Model Airplane Club held their monthly free flight contest Nov. 30 and reported the following winners:

- Class A—1, Tommy Jenkins; 2, John Marshall; 3, Lt. R. Randolph.
- Class B—1, Dutch Van Tassel; 2, John Lenderman; 3, Lt. R. Randolph.
- Class C—1, Dean Hughes; 2, Jack Crose; 3, Fred Mosier.
- Juniors—1, Fred Mosier; 2, Russ James; 3, Ronald Mosier.

* *

The Oakland Cloud Dusters elected the following officers for 1948: Michael G. Demos, Pres.; Sergius Milisich, Vice Pres.; Myrtle Robbers, Secy-Treas.; Manuel Andrade, Sgt.-At-Arms.

* *

California Association of Model Clubs elected the following officers for 1948: Vernon Oldershaw, Pres.; Ocie Randall, Vice Pres.; Roy Mayes, Secy-Treas.; Bill Sweet, Corr. Secy. Meetings will be held quarterly, a minimum of four a year.

* *

The Fresno Control Flyers is a new U-Control Club, organized July 1947, sponsored by the Junior Chamber of Commerce. The club consists of 33 active members, meets twice monthly, and elected the following officers for 1948: Roy Bitters, Pres.; Bob Frity, Vice-Pres.; Eldon Webster Sr., Treas.; Bill Price, Secy.; Paul Nieto, Contest Direc. An annual contest will be held June 13 unless it conflicts with some other major contest.

Results of the Airmail contest between **Oakland Cloud Dusters** and **Australian Eastern Suburban Model Airplane Club**:

Oakland Cloud Dusters	6 Highest Flights
James Tangney 14:52.0	"C" & "D" H.L. Cabins
Peter Demos 8:30.5	"D" H.L. Fuselage
Manuel Andrade 8:12.4	"D" H.L. Fuselage
Myrtle Robbers 8:07.2	"D" H.L. Stick
Larry Mongeon 7:38.6	"C" H.L. Stick
Michael Demos 6:13.5	"D" H.L. Stick
Eastern Suburban Model Airplane Club	3 Highest Flights
J. M. Fullarton 10:11.2	Wakefield Type
A. Lim Joon 9:42.2	H.L. Stick
R. Ingleninger 4:43.2	"Atom Smasher" design

Here are results of the **Cloud Dusters' Indoor Helicopter Challenge Round Contest** held Jan. 4, 1948:

Donald Robbers, 2:25.6; Michael Demos, 2:15.2; James Tangney, 1:05.7; Robert Blau, 0:38.3; Carl Rambo, 0:05.4.

Results of the **Outdoor Hydro Challenge Round Contest**, Jan. 11:

- Class C—Row Stick—1, Donald Robbers; 2, Carl Rambo.
- Class C—Row Cabin—James Tangney.
- Class D—Row Stick—Michael Demos.
- Class D—Row Cabin—Manuel Andrade.

* *

On Dec. 5 the **Thermal Thumbers Model Airplane Club** celebrated their first anniversary. Clarence Searcy, Contest Director, held a party for 32 members, with wives and sweethearts to add to the glamour of the affair.

Colorado

R. J. Beckman, Secy. of **Rocky Mountain Canaries** of Boulder, recently wrote the following enthusiastic letter: "Since I last wrote you the RMC has been very active. In addition to taking a good two-thirds of all prizes offered at the contests in the region, we held a meet of our own on 24 August 1947. We are justly proud of this contest as we didn't have one complaint the whole day and we had an exceptional number of contestants. It went so smoothly that we were able to com-

plete the judging and award the prizes with time to spare. We are already planning a bigger and better meet for next summer.

"As soon as the contest was over, the RMC organized and are conducting a class in model aeronautics designed primarily for younger boys and girls. At present the training program is in the form of a series of classes in which students are guided in the construction and flying of a control line club. For this purpose, the F and B Model Aircraft Co. supplied us with 6 of their *Sky Box Trainer* kits. The American Legion Post #10 of Boulder is supplying engines and accessories for the planes. (Post #10 is sponsoring the RMC and too much cannot be said for the help they have given us.) Until a short time ago the RMC has been primarily a control line club, but the past two months has seen a rising interest in free flight that has almost pushed control line out of the picture. We have scheduled our first club free flight contest for Feb. 15 and are planning an open free flight contest next summer along with our control line meet. I for one am convinced that the RMC will outdo the rest of the region in free flight as well as in control line. As you can see, ours is the top club in the region and we intend to stay on top."

Your *Club News* reporter likes the spirit and determination of this outfit and feels they are going to give other clubs a "boulderful" of competition.

Florida

Gene Johnson, pres. of *Clearwater Model Airplane Club* reported that speed, crackups and stunts highlighted a windy session at the city parking lot on North Osceola Ave. where 100 spectators turned out to watch the contest. Everyone got a big thrill when a biplane owned by Dick Shewell won the stunt feature. Almost immediately after the ship took off it lost its top wing. In spite of the damage the little plane held the air, went through some outstanding maneuvers and finished with a perfect landing. Because of the high erratic wind, spectators were treated to 5 or 6 crackups out of the 30 entries handled by the local boys. Prizes for the event, consisting of sports items, were sponsored by Walker's Sporting Shop. Other winners were:

Speed—Class A—Ned Anderson.
Speed—Class B—Gene Johnson.
Speed—Class C—Charlie Clark.
Scale Prize—Lloyd Hicks.

Illinois

The *Tri-City Modelers* of LaSalle, Peru & Oglesby elected the following officers for 1948: Ray Broviak, Pres.; Joe Locasto, Vice-Pres.; Bob Davidson, Secy.-Treas. The club will hold its annual U-control meet in July, exact date to be announced later.

* *

Chicago Flying Gremlins U-control gas model airplane club was recently re-organized. The new officers are: Bob Twining Jr., Pres.; George Chirigos Jr., Secy.; John Anderson, Treas. For the past few months the club has been flying at Winnemac Park, 2200 W. Winnemac Ave., on Sundays.

Indiana

Glenna Williamson, Secy. of *Anderson Johnnies*, sent us a comprehensive letter on the activities of this club. Unfortunately we do not have enough space to present everything the secy. wrote us but we feel that several things deserve mention here. At a dinner-meeting Dec. 12 the club instigated the organization of a State of Indiana Assoc. whose purpose would be:

PIERCE SUPER POWER PLANTS now in KIT FORM

PRECISION PARTS EASY TO ASSEMBLE AND FAMOUS PIERCE QUALITY THROUGHOUT

The MODEL R KIT

◆ A powerful contest winner with rotary valve for terrific speed and power. Cylinder head precision machined aluminum; hardened and ground piston, micro honed and hand lapped for a perfect seal. Dynamically balanced crank shaft of hardened steel. Rotary valve for sustained high speeds and easy starting. Easy to assemble—easy to mount—easy to fly. Equal to any \$20 motor on the market.

ROTARY VALVE
.298
DISP.
1/5 H.P.

LESS COIL AND COND.

\$6.95

ADD \$1.50
IF
WANTED
WITH COIL
AND
CONDENSER

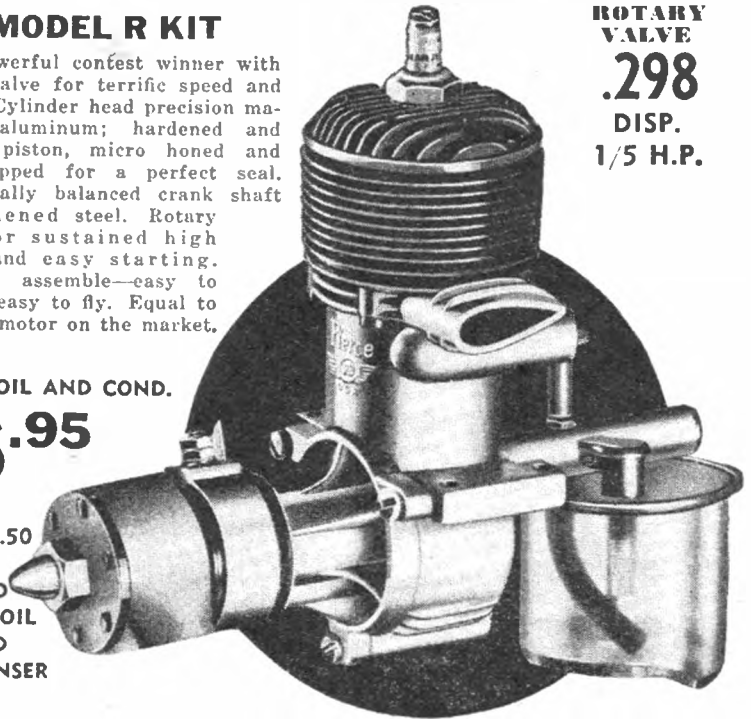

THE PIERCE MODEL "J" KIT

.290 Disp. — 1/5 H.P.

Precision engineered for easy starting. Beyond question the greatest motor value in years! Hardened and ground steel piston, micro honed and hand lapped for high turbulence—high compression. Brings you expensive engine features at a popular price. Ask your dealer to show you this great new motor.

Less Coil and Condenser

\$4.95

Add \$1.50 if wanted with
Coil and Condenser

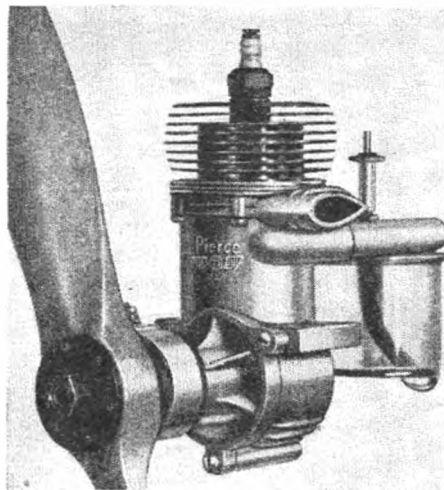

Order from your dealer. If he cannot supply, write direct.

PIERCE INDUSTRIES

844 W. ADAMS STREET

CHICAGO 7, ILL.

IF YOUR DEALER CANNOT SUPPLY, USE THIS HANDY COUPON

PIERCE INDUSTRIES, 844 W. ADAMS ST., Dept. MN4
CHICAGO 7, ILL.

ENCLOSED FIND \$..... for ENGINE KIT CHECKED BELOW
Please add 25c to cover postage and packing.

Model R @ \$6.95.
Add \$1.50 for coil and
condenser.

NAME

Model J @ \$4.95.
Add \$1.50 for coil and
condenser.

ADDRESS

CITY STATE

BUILD and FLY

**Control-line
World War I "CRATES"**

Build one of these flying scale control line copies of famous World War I fighters and you'll want an entire squadron! Scaled 1 inch to the foot, they take Class A, B or small C ignition or 'diesel' engines. For fun in sport flying and "1sts" in stunt and scale events try a World War I "Crate".



NIEUPORT 17C.1 - Wingspan 27", Length 17 1/2"



FOKKER D.VIII - Wingspan 26 1/2", Length 18"



SOPWITH CAMEL - Wingspan 28", Length 18"



SPAD 13C.1 - Wingspan 26 1/2", Length 20"



FOKKER D.VII - Wingspan 28", Length 22"

Buy from your
Local Dealer
Support the business that
supports your community.

\$3.50
EACH

(If there is no dealer near you - add 25¢ for each kit ordered by mail to cover handling & postage.)

Do you have a copy of the CONTROLLOG - the new catalog-manual, a "who's who" of more than 100 U-control craft? Ask your dealer, or send 15¢.

POLK'S MODEL CRAFT 314 FIFTH AVE. NEW YORK 1, N.Y.
DEPT.-MN97 **HOBBIES**

DEALERS: Midwest - 223 S. Wabash, Chicago 4

More profit with Polk's!
Write for sales bulletin.

STUNT FLYING IS EASY

LEARN with the ADVANCED TRAINER. It has everything a good stunt ship should have and it's reasonably priced.

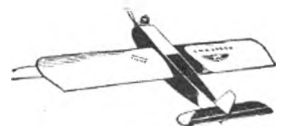

COMPLETE MANEUVERABILITY

Figure '8's, Wing Overs, Loops, Inverted Flying

SIMPLE TO CONSTRUCT

Built and test flown in 8 hours

GOOD STABILITY

Easy to control. Steady as a trade wind

Senior Model \$4.95

FOR .60 DISPLACEMENT

Junior Model \$3.95

FOR .30 DISPLACEMENT

IMMEDIATE DELIVERY

GREAT LAKES MODELS 1125 Brown Ave., Erie, Pa.

1. To establish an efficient model airplane contest calendar the year around.
 2. Pooling of contest personnel and equipment.
 3. Aid clubs in building up their membership.
 4. Encourage more youth participation.
 5. Facilitate closer cooperation with organizations, such as, The American Legion, Civil Air Patrol, and Air Defense Command in their model airplane programs.
- Mr. Frank Nekimken, American Legion National Headquarters, Indianapolis, who was present at this celebration, offered his services to the Association. Also at this banquet, the annual achievement awards were presented to: Harry Murphy Jr., winner of the Junior Division Award, and Harold Tremps, winner of the Senior Award. Competition was pretty close this year with 14 year old Luther Marr Hays running a close second in the Junior Division, trailing by only 15 points. Mr. Tremps was ahead of second place Luther Hays (father of the younger) by 92 points. These points are awarded for construction, attendance, placing in contests, and provision is made for extra points for any outstanding achievement. Officers of the Anderson Johnnies for 1948 are: Robert Johnson, Pres; William J. Campbell, Vice-Pres., John Hobbs, Treas., Glenna Williamson, Secy.

The Hoosier Capitoliners' third year of existence was officially opened by Wilbur T. Portteus Sr., last Jan. 7. Appointments of committees and boards took up the bigger part of the meeting. Geo. Clingman, Geo. Reed and Frank Nekimken are on the Advisory Board. Jim Mitchell on entertainment, Bill Pazder on Membership Board, and Geo. Reed and Frank Nekimken on the Education Board. Geo. Reed of Display Craft Studio has turned the shop over to the boys every Tuesday night for 25c per person. The shop is complete with power tools, spray booth, projector for enlarging plans, work tables, engine testing etc. The Capitoliners are setting their goal at 100 members this year. If you are interested and live near Indianapolis, contact B. A. Stellhorn by phone at Franklin 7942 or by mail c/o Hoosier Capitoliners, 710 S. New Jersey, Indianapolis.

The Purdue Aeromodellers, model club at Purdue University, has a large workshop in the basement of the Purdue Memorial Union Bldg. and at present are doing most of their winter flying at the Purdue Armory on Saturday afternoons. The club is negotiating with the Uni-

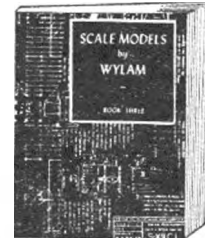

No modeler's library is complete without the three famous volumes of WYLAM'S Masterplans... Real collector's books!

Book 1.....\$1.50
Book 2.....\$1.50
Book 3.....\$2.00

At your dealer's or direct from

AIR AGE INC.
551-5th Av. N.Y.C. 17



BLOCKBUSTER 8c
Postage 3c

ALUMINUM		STANDARD TYPE	
Adjustable Pitch		Die Cast White Metal	
1 1/2"	2 Bladed	1 1/2"	3 Bladed
2"	No. 13 .05	2"	No. 25 .08
2 1/2"	No. 14 .07	2 1/2"	No. 26 .10
3"	No. 15 .08	3"	No. 27 .15
3 1/2"	No. 16 .10	3 1/2"	No. 28 .20
4"	No. 17 .12	4"	No. 29 .25
4 1/2"	No. 18 .15	4 1/2"	No. 30 .30
ALUMINUM		Spinner Type	
.010 Wall		3 1/4"	No. 725
per foot		4"	No. 830
1 1/8"	12	4 1/2"	No. 935
3/32"	12	5"	No. 1035
1 1/4"	12	5 1/2"	No. 1135
		6"	ADD 3c EACH
			FOR MAILING

Boat and airplane fittings—parts also largest complete line of O-HO-OO gauge Railroad parts available anywhere.

Send for your catalog and assortment today!
Catalog only 5c to cover mailing.

SELLEY MFG. CO., Dept. 304, 1377 GATES AVE., BROOKLYN 21, N. Y.

versity for a plot of ground for a permanent flying site and hopes to have it in operation by spring. AMA U-Control record trials will be held in April and May, and a U-Control contest the end of May. The club is mostly control line, with a few exclusively free flight, and some who build both.

Iowa

One of the largest model airplane contests in the nation — The Tall Corn Model Airplane Meet, held annually at Marshalltown — will be sponsored this summer by the Iowa Civil Air Patrol. This announcement was made simultaneously by Wallace R. Blake of Marshalltown, originator and director of the Meet, and Lt. Col. W. O. Fuller, Deputy Commander of the Iowa Wing, CAP.

At the same time, Colonel Fuller revealed the Iowa CAP has made a bid for the regular District CAP Model Contest, which draws entries from all the

PHANTOM

NOW ONLY
\$13.95

LESS COIL AND
CONDENSER

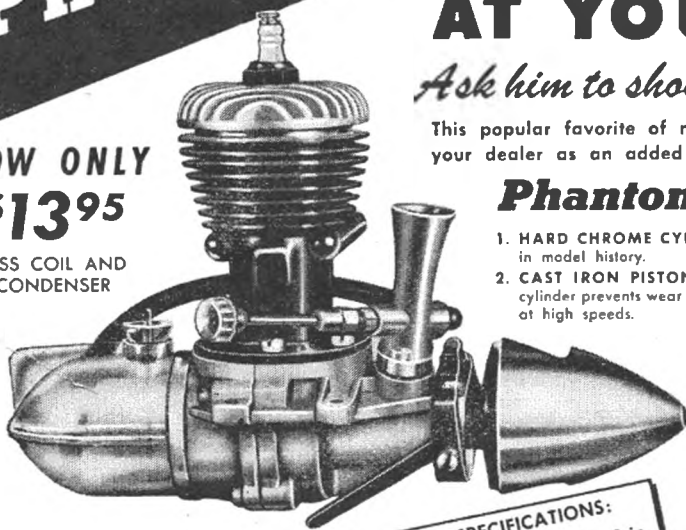

\$14.95 complete
with coil & condenser

CHECK THESE SPECIFICATIONS:
Displacement .295 cu. in. Stroke .750 in.
Horsepower .1/5 Bore .711 in.
Rated Class "B" Under N. A. A. Rules

NOW AT YOUR DEALERS!!

Ask him to show you this Outstanding Engine

This popular favorite of modelers everywhere may now be purchased direct from your dealer as an added convenience to you See it TODAY!!!

Phantom FOR '48 HAS ALL THESE PLUS VALUES:

1. HARD CHROME CYLINDER LINING—first in model history.
 2. CAST IRON PISTON—in a "mirror-slick" cylinder prevents wear and loss of compression at high speeds.
 3. SEAMLESS EXHAUST STACKS WELDED TO CYLINDER—leakproof and perfectly round for mounting extensions.
 4. MACHINED DURAL HI-FREQUENCY TIMER—hi-speeds without floatations...no castings to break...easy point adjustment.
 5. PRECISION GROUND NEEDLE VALVE—finer adjustments make starting easier and smoother running.
 6. MOTOR EASILY INVERTED—turn tank 180 degrees.
 7. BEAUTIFULLY FINISHED IN BLACK AND ALUMINUM.
 8. STANDARD EQUIPMENT INCLUDES—Spark Plug, Polished Spinner and Gas Tank.
- ALL THIS . . . AND CHAMPIONSHIP PERFORMANCE TOO!!

If your dealer does not yet have Phantom . . . order direct giving name and address of the dealer.

PHANTOM MOTORS DISTRIBUTING CO.
806 EAST GAGE AVENUE LOS ANGELES 1, CALIFORNIA

north central states. If accepted, the two contests would be combined into one of the largest exhibitions of model airplane activity ever held. Arrangements are being made with the Taylorcraft Corp. Alliance, Ohio for awarding a new 65 hp \$2300 Taylorcraft airplane as grand prize for the 10th Jubilee Tallcorn Model Meet. The Fort Des Moines Army Post is being considered as site of the Jubilee Meet which is scheduled for July 3-5.

Kansas

Some 50 model airplane enthusiasts representing 60 model clubs met at the Hotel Continental in Kansas City, Mo. on Jan. 3-4 for the 3rd Annual Meeting of the Mid States Model Aeronautical Assoc. High point of the meeting probably was the announcement that Mid-SMAA President C. O. Wright was elected A.M.A. President. Also many new proposals for the Precision Stunt, Novelty Stunt and Flying scale were recommended.

Maine

A gas model club called *The Flying Maniacs* was recently organized in Augusta. All 14 members belong to the A.M.A. The following are newly elected officers: Howard E. Smith, Pres.; Raymond Vigue, Secy.; Richard Main, Treas.; Louis Marden, Publicity man. Plans for a few contests under A.M.A. rules are already underway. Those interested in this new club should contact Secy. Raymond Vigue 143 Northern Ave., Augusta. In answer to a question that Mr. Smith sent in, we wish to inform everyone that all club news should be sent to the same address as MODEL AIRPLANE NEWS, namely: 551 5th Ave., N.Y., 17, N.Y., attention of Club News Dept.

Maryland

Aero Craftsmen Gas Model Club of Baltimore elected the following officers for 1948: John Gunther, Pres.; Charles Peacock, Vice Pres.; Larry Simms, Senior Advisor; Pete Truman, Treas.; Yvonne Gunther, Secy.; Max Ripken, Bob Stevens and Bucky Verrier, Board of Directors; Leonard Watson, Publicity Direc. Bucky Verrier informs us that the club has quite a vigorous program planned for the coming year which includes bus trips, a design contest and some social affairs.

Massachusetts

It is requested that all correspondence to the *Lawrence Gas Model Club* be mailed in care of Edmund Chulada, 164 Park St., Lawrence, and not to John O'Rourke, Bay State Bldg.

* *

Henry R. Jex, Pres. of a newly formed model airplane club at Massachusetts Institute of Technology, called *The Tech Model Aircrafters*, writes us that the club has been officially recognized as a regular Institute activity and were given a room in the electronic lab for their workshop and clubroom. An interesting feature of this club is its research program. Members work on a project of their own choosing, some of which are: Power effects of gas models; Rubber-turn chart; Vee-tails; Effect of Stabilizer Area; H-L Glider Construction; Channel-Wing design; and Compression-Ignition. Recently the club obtained use of a nearby armory for a Saturday afternoon and held an indoor contest. A U-control stunt contest was also planned. The club reports that some developments they have been working on are progressing well, such as Mite

Guaranteed SMITH Ignition



Tuffy

"World's easiest coil on batteries. Has built-in mounting lugs with screws. No soldering! No extras."

Smith Firecracker

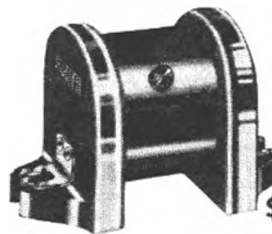

\$2.75



Snappy

"Red-hot performance... guaranteed satisfactory—replaceable at factory."

Smith Competitor



\$1.95

Easy

"New fuse-type mounting clips. Anchored central core. Uncond. guaranteed!"

SMITH COILS

105 Pasadena Avenue, South Pasadena, Calif.
IF NOT OBTAINABLE, ORDER DIRECT
FREE: send for 3-COLOR "COILTEER" DECAL

POWER YOUR MODEL RACER

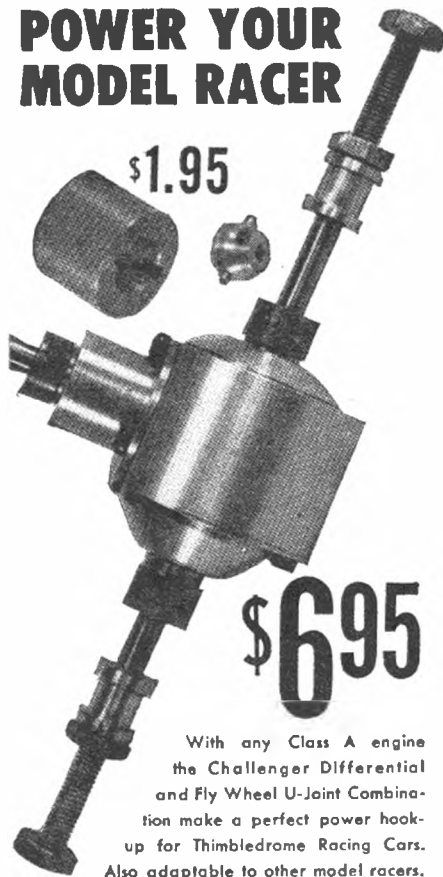

\$1.95

\$6.95

With any Class A engine the Challenger Differential and Fly Wheel U-Joint Combination make a perfect power hook-up for Thimble-drome Racing Cars. Also adaptable to other model racers.

Differential is precision machined from Dural with case hardened steel gears and naval bronze bearings. Housing is 1 1/2" in diameter, axle 6 1/8" long, drive shaft 1 3/4" long.

Write for Descriptive Literature



At Your Hobby Shop or Sold Direct Plus Postage

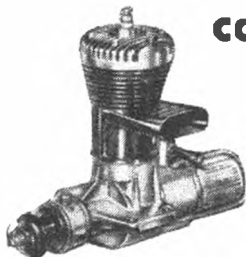

CONTESTOR
\$18.50

An engineering triumph in the Class C field. Your money can't buy better performance or finer dependability.

LUCAS & SMITH
MANUFACTURING CO.

2636 HUMBOLT ST. • LOS ANGELES 31

with glow-plugs and Atoms with Arden needle valve conversion. Mr. Jex states that cooperation among the members is wonderful and he predicts his group will be well known in a few years. Your club news reporter can only add that with this kind of a beginning — the sky's the limit!

Minnesota

Roger C. Sorensen, Corr. Secy. of *Piston Pushers Club*, is proud of the accomplishments of his club and believes some of these things are worthy of mention in this column. *The Piston Pushers* have managed to take the lion's share of honors at upper mid-west contests. Winnings for 1947 consisted of 17 trophies, plus 15 first, 14 second and 12 third places, along with many contest grand championships. Dan Philipbar, retiring Pres. of the club, deserves especial credit for the fine work he has done in office by putting the club back on its feet. Mr. Sorensen writes that the club especially likes M.A.N.'s "West Coast Tips" column and would appreciate hearing from fliers and clubs out there due to the fact that fliers in this area are usually behind the west-coast designs.

New Jersey

The former *Passaic Rubber Heels* group is now the *Passaic Model Club*. M. Bakels, Rec. Secy. reports that the change was voted Dec. 11. The club has outgrown its former title, and since it embraces model aircraft in all its phases, plus model boat and race car building, the members feel the new title is more truly descriptive. The club, now chartered by AMA, chose the following officers: A. Casano, Senior Advisor; H. Rublack, Pres.; B. Spille, Vice-Pres.; M. Bakels, Recording Secy., and W. Deetz, Treas. The club is negotiating for purchase of sufficient land for its own free flight and U-control requirements. The members would welcome correspondence with other clubs. Address all letters to: M. Bakels, 102 Main Ave., Passaic, N. J.

New York

The Queens Thermal Thumbs will hold their 3d Annual Model Airplane Contest, sanctioned by AMA, on July 11—rain date July 18—at Beth Page, L. I. Events will be: Classes A, B, C & D free flight gas, combined towline & combined rubber (fus. & stick). The contest starts at 8:30 a.m. and ends 5:30 p.m. Directions to the field are: take Route 24 east on Long Island until it crosses Wantugh Parkway; then continue 1 mile and the field is on the right hand side.

* *

14 model clubs comprise the parent organization known as *North Eastern Model Airplane Conference* which came into existence when several of the leading clubs decided to do something about combining the area to obtain a possible free flight field. Cooperation among these 14 clubs was so good they decided to organize. The following are the newly elected officers: Sidney November, *New York Aeronuts* — Chairman; Bernard Litchterman, *Brooklyn Skyscrapers* — Vice Chairman; Arnold Penenberg, *Brooklyn Skyscraper*, — Rec. Secy.; Salvatore Fruciano, *New York Aeronuts* — Corres. Secy.; William Fletcher, *Prop-Spinners* — Treas.

* *

Last October the *New York Aeronuts* ended a highly successful contest season. The club gained most of its honors in free flight gas events, particularly in Class C. Flying *McCoy* and *Hornet* ships, Kenny Fisher and Sid November took

DEALERS...

HERE'S

THE SPOT

FOR...

- Complete line of model railroads, planes and boats
- Shipments within 24 hours
- Maximum discounts

Dealers—established and prospective—write for our latest catalog and discount sheet today.

SKY HOBBY

INCORPORATED
804 GRAND AVE. KANSAS CITY 6, MO.
NOTHING SOLD AT RETAIL

FREE SUBSCRIPTION for AIR WAYS Photos

We need good clear photos, especially of free flight ships of all classes and flying scale models. One year subscription to *MODEL AIRPLANE NEWS* will be given for each photo used in our Air Ways department.

JET-CONVERTER

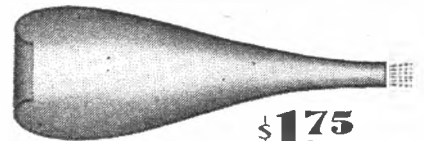

\$1.75
POST PAID

HERE IT IS!...

A Thrill For Model Builders

Converts Any Model Gas Engine Into A Jet Engine! Build It Yourself. Complete Set of Plans Only \$1.75 Postpaid. Order Today!

MODEL EXPERIMENTAL LAB.
P. O. Box 186 West End Station
Colorado Springs, Colo.



PITTSBURGH'S WHOLESALE DISTRIBUTOR...

✓ All leading lines

- MODEL AIRPLANES
- MODEL BOATS
- MODEL SUPPLIES
- FULL LINE OF MOTORS

Dealer's Price List Available Upon Request

WHOLESALE ONLY

J. SPOKANE & CO., Inc.

1106 Fifth Avenue, Pittsburgh 19, Penna.

PACKED WITH POWER!

The New, Sensational Class A

DEEZIL

at the amazingly low price of

\$12⁹⁵ LESS TANK

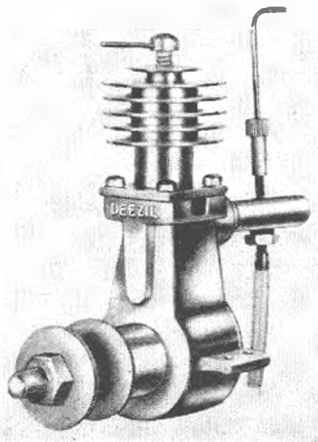

Gotham proudly presents the world's sweetest and hottest little diesel engine—the DEEZIL "A." We put a solid year of design and development into this engine to give you a diesel that has everything—and now, quantity production gives you in addition the lowest possible price. The DEEZIL is the perfect power plant for planes, boats and race cars. Its compact streamlined shape lends itself to easy installation and perfect cowling. Easy starting and steady running give you 100% flying time. Operation is simple and economical. The DEEZIL is light enough for the tiny jobs yet powerful enough to pull a six foot free-flyer straight up. And it will run for years and years without attention because it is simple and rugged. Order a DEEZIL today for the thrill of a lifetime.

- ★ DEEZIL STARTS EASILY
- ★ DEEZIL IS RUGGED
- ★ DEEZIL RUNS STEADILY
- ★ DEEZIL IS POWERFUL
- ★ DEEZIL IS LOW PRICED
- ★ DEEZIL IS GUARANTEED

GET your DEEZIL from your favorite hobby shop, or if he is sold out, send only \$1.00 to GOTHAM and we'll ship C.O.D. for balance. We pay postage.

DEALERS AND JOBBERS WRITE

GOTHAM HOBBY CO.

107 East 126th St., Dept. M
New York 35, N. Y.

Meetings will be held once a month. The club has a solid foundation of experienced modelers and expects to really go places in the coming contest season.

Pennsylvania

With 32 members and 6 visitors in attendance, a meeting of the Doylestown Kiwanis Aero Club was held Dec. 29 when the following officers were elected: James Campbell, Pres.; Walter DeSousa, Vice-pres.; D. Warner, Secy.; W. Lownes, Treas.; J. Carlson, Sergeant-at-arms; Ralph Biddle and Walter DeSousa, Federation representatives; John Happ, Chairman; D. Rohde, G. Shaughnessy, J. L. Friling and Ralph Biddle, Directors.

It was decided to hold a school of aerodynamics to teach all younger members of the club how to build and fly control line as well as free flight models. The school will be conducted by Ralph Biddle of Neshaminy, who is a veteran model builder and official, aided by Frank Horn and John W. Brinser, Jr. Schooling is to be given every Thursday evening. William A. Lehman, sponsor of the club, announced that W. Harry Watson & son, local automobile dealers, contributed space in their South Main St. building to be used as a workshop.

16 County Seat business men are aiding this newly formed workshop by contributing tools, supplies, and other equipment. "I think what these businessmen have done is one of the finest gestures we have been shown since we organized," said President Campbell. "Any businessman is invited to attend and inspect the workshop at any time."

At their Jan. 28th meeting, the Kiwanis Aero Club's guest speaker, Comdr. Richardson, gave a very informative address on the development of military planes. He later visited the new workshop at Watson's Garage and was much impressed with the progress shown.

* *

The Pittsburgh Conference on Model Aeronautics is a new organization established to coordinate the activities and more thoroughly publicize contests in the Pittsburgh area. As a result of the mass meeting of all Pittsburgh modelers on Jan. 10, M. J. Thomas was reelected Conference Coordinator; Joe Mellot, publicity director and Buzz Bullock, Secy.-Treas.

Texas

The first annual West Texas Model Airplane Contest will be staged in Amarillo June 12-13 at a site yet to be chosen. It will be open to entries from the Panhandle, South Plains, Eastern New Mexico and Western Oklahoma. Richard M. Kidwell Jr., owner and manager of The Kidwell Model Shop, is staging the contest and reports it will include all classes in free flight, U-Control, speed races, stunts and exhibition flying. There will be high priced awards in all divisions.

The Veterans of Foreign Wars of Uvalde is sponsor of the control line Model Airplane Meet Feb. 22. The meet comprised the 3 events: speed, stunt and sportsman. The sportsman event was judged on a point system and the winner adjudged the best model flyer, not necessarily the best model builder. There were no age or engine displacement classifications in this event, the only prerequisite being a fixed gear on the model. Takeoff, landing, and flight stability were the main points judged. Prizes consisted of a magneto, several engines, several stopwatches, etc.

Virginia

Robert M. Bruce, Secy.-Treas. of the

WEST COAST

RETAIL

HOBBY SUPPLIERS

WE FEATURE

VIVELL DIESEL at \$12.50

ORWICK "64" at \$32.00

We Handle All National Advertised Engines, "U" Control Kits and Accessories, Free Flight and Sailplane Kits.

KIRKS HOBBY HANGAR

"U" CONTROL SPECIALIST

2320 ENCINAL AVE., ALAMEDA, CALIFORNIA

A New Low for High

HEY, you, stop a while and visit. We aren't going to hi-pressure you. Modeling is our hobby too. If you don't believe it, you ought to see a copy of our dime catalog. In it you will read our frank opinion of the products we sell. We tell you exactly what you get in the kits and the actual specifications of the models. And to top all of this it also tells stories and incidents about modeling in an informal way. If you want to buy a model you have to look it up in the price index which is a new low for hi-pressure.

OLE RELIABLE MODELS

Box 756

Cleveland 22, Ohio

NATIONAL BOYS' CLUB WEEK

APRIL 5th TO 11th

The principle of Boys' Clubs is to build good citizens, but in doing so they have demonstrated their effectiveness in lessening delinquency. This is not a theory, but a fact!

26" SCALE MODELS \$4.95 Postpaid



CHRIS CRAFT'S "FLAGSHIP" 26" - Comb R. & V. Hull



OWEN'S YACHT "FLAGSHIP" 26" - Round Hull

BUILD NOW FOR RACING OR DISPLAY
Complete Kit 26" length, \$4.95 each, postpaid
Trim beautiful crafts you'll be proud to build and own.
Designed from actual Bent Co. plans.
COMPLETE KIT—contains everything—cement, sealer, brush, blade, copper shaft and trim wire, cast twin display propellers, windows, plastic decking, 22 ft. balsa planking, flag, etc. (less finish paint). Interior plans supplied.
MARINE DRIVE KIT for A-B or C. Engine Complete, \$2.65
20 PC. SET WHITE METAL FITTINGS \$2.50
Send for FREE Booklet.
TRIM-CRAFTS, 312 E. Wisconsin Ave.
ROOM 207B, MILWAUKEE, WIS.

When *OTHER* Prices go Down.. K&B Performance **GOES UP!!**

The Records Tell The Story!

K&B HALL OF FAME

1. Fred Whiting—1st place—Class B Sr. F. F.—Nationals
2. Jerry James—1st place—Class B Jr. F. F.—Nationals
3. Don Newberger—1st place (120 mph) Class 3 Speed-Open—10/18/47
4. Lew Mahieu—1st place (117.64 mph) Senior Class 3 Speed—10/18/47
5. Ray Acord—Official AMA Record—32:02.6 mins. Free Flight-open
6. Paul Conrad—Official AMA Record—98.97 mph—Class 3 Jr. U-Control Speed

WATCH THIS GROW

K & B "24"
16⁵⁰
(less c & c)

TORPEDO
"29"
18⁵⁰
(less c & c)

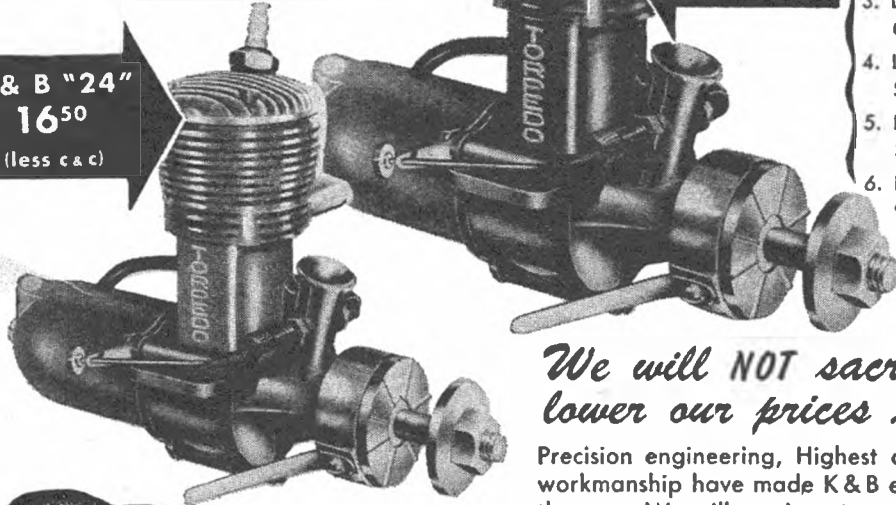

We will NOT sacrifice QUALITY to lower our prices

Precision engineering, Highest quality material and skilled workmanship have made K & B engines the great champions they are. We will continue to produce quality—not quantity.

TORPEDO

K & B MANUFACTURING COMPANY
6901 EASTERN AVENUE • BELL GARDENS, CALIFORNIA

newly organized *Torque Twisters Model Airplane Club* of Langley Field reports that full credit for organizing the club goes to its President, Sgt. Paul Shaffer, who recruited 20 members. This sounds like a good start for any new club.

Argentina

J. Cartoceti, Pres. of the *Asociacion Aeromodelistas "Tuco Tuco,"* Buenos Aires, writes that they keep up with airplane publications of other countries and find them very useful from the point of view of reference and design.

England

F. C. Saunders is keeping us up to date with the *Batteria Aeromods.* The club is situated in the Battersea Men's Institute in S.W. London, and since the club is run in conjunction with the Institute it has a number of advantages over the usual club in that they have no rent or lighting to pay and have a dry canteen, a hall for indoor flying, and a playground for control line flying. All outdoor flying is done on Hounston Heath which is quite close to London Airport; there is a ban on power flying in the London area. The club records are as follows: 62 mph with a Mills Class A Diesel control line; 9 mins. 10 sec. O.O.S. with a 15 sec. motor run in the power class (this was also a diesel engine); 2 min. 10 sec. in the rubber duration class; and 1 min. 53.8 sec. in the indoor R.T.P. class.

The Society of Model Aeronautical Engineers held its annual General Meeting Nov. 30, 1947 at Londonerry House, Park Lane, London W. The following men are newly appointed officers: Lord Brabazon, Pres.; Sir Robert Bird Bt., Vice-Pres.

Dealers!

WERE YOU IN THE INTERNATIONAL 1947 PROFIT LINE?

**IF NOT
GET IN NOW!!**

We are accepting import orders for the famous Schuco (made in Occupied Germany) autos—The Gear Shift "Examico"—The Remote Control "Telesteering"—The Horn blowing and steering "Akoustico"—The Self Starting and Reversing "Garaging" & The "Racer"—Also the complete fully painted "Britain Line" of Farm figures, Zoo animals & Soldiers of the World—in all gauges—Astounding and revolutionary imports will be added during the year—Get your orders in *Now*—These are all year round sellers.



INTERNATIONAL MODELS, INC.

879 Eighth Ave., New York 19, N.Y.
BETWEEN 52ND & 53RD STREETS

Now—FINEST of the DIESELS!

**QUICK STARTING
TROUBLE FREE MICRO-DIESEL**

SIMPLE NEW DESIGN—CUSTOM MADE. You forget ignition and starting troubles with a MICRO-DIESEL because—

1. of the watch-like precision fit of the piston to the cylinder.
2. building of a perfect carburetor.
3. of a new catalytic fuel which ignites at a lower compression.

Specifications—Piston displacement of .13 • Adjustable compression
High carbon steel sleeve • Pistons lapped and honed • Crank case and housing in single aluminum casting •
R.P.M. 6000 to 8000—idles at 2000 •
Ball connection • Weight 5/2 oz.

**NOW
\$14.95**

Immediate Delivery. Write for literature.
DEALER inquiries invited

**SPECIAL
MICRO-DIESEL
CATALYTIC
FUEL**

\$1.00 per pint.

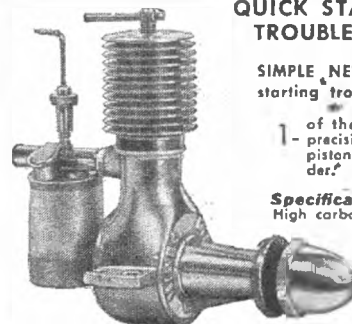

MICRO-DIESEL CO. 609 WOODWARD AVE., DETROIT 26, MICH.

Megow MODELS

\$1.00

2000 scale M. P. H.

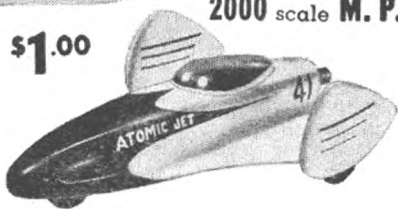

ATOMIC JET CAR

CONTENTS

CARVED BODY
METAL AXLES
ALL PARTS SHAPED
EASY CONSTRUCTION PLAN

METAL WHEELS
BUBBLE CANOPY
RACING LUGS & DECALS

New



60¢

JET MIDGET

CONTENTS

One piece shaped body
Die cast steering wheel
Lugs For Wire Racing.
Easy Construction Plan

Metal Axles.
Metal Wheels.
Printed sheet Decals

JET GUN



All metal 35¢

1. Self centering hole for Jet Tube.
2. Powerful tension spring.
3. Colett chuck on plunger for releasing needle.
4. Use any standard phonograph needle.
5. Efficient as one can be made.

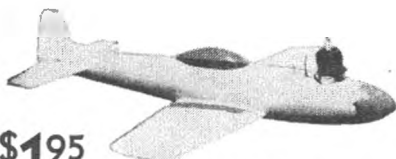

\$1.95

SKY STREAK

Lic. under J. Walker "U" Control Pat. No. 2,292,416

All parts carved and shaped ready for assembly

BUILD AND FLY IT IN 4 HRS.

UC-2 Tyro	3.50
UC-4 Bantam Special	2.75
UC-5 Competitor	5.50
Battery Boxes	.40
Switches	.30

BOATS with Carved HULLS

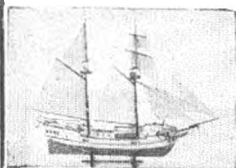

G-13 Hispaniola

G-4 Great Republic
G-5 H.M.S. Bounty
G-12 Xebec
G-15 Arabella
G-16 Seabird
G-17 Bear of Oakland

\$2.50 EACH

SEE YOUR DEALER If your dealer cannot supply you send 10% postage and order direct.

THE MEGOW CORPORATION

Philadelphia 22, Pa.

World War I

(Continued from page 23)

early aircraft were framed in steel and aluminum.

His early aircraft were sensational in that they flew. His later products were sensational in that they flew better, all factors considered, than those of most of his competitors. The underlying theme of all Breguet designs was a simple beauty and grace coupled with common horse sense, which made his ships extremely useful. They were neither the biggest, fastest nor farthest flying, but they did well the job that was intended for them with a minimum of regrets from the purchaser.

Breguet Model 14

The biggest purchaser when the war started was, of course, the French government. Breguet's first official product was a version of the 1910 biplane adapted for whatever use the French army could find for it. But from his factory at Villacoublay came a pusher biplane in accordance with the style of the time, which performed some good service at the Front and later was used as a school machine until mid 1917. Early in 1916 Breguet brought out a tri-motor bomber (three 250 hp Renault engines) of considerable size, which was able to fly at 6500 meters for three hours while carrying a load of 1200 kilos. Converted to feet and pounds this doesn't seem like much in terms of performance today, but the ship had the French Air Ministry quite excited.

While his tri-motor was pleasing the military authorities, Breguet put the finishing touches on model 14, one of the sweetest ships ever to take to the air. The surest method of identifying a 14B.2 or 14A.2 was to read the designation painted on the rudder. By way of review, the letter A indicated "Corps d'Armee" (army cooperation) while B indicated "Bombardment". The figure "2" indicated number of men in the crew.

Besides the rudder designation, these general characteristics often permitted proper identification: 14B.2—window below the gunner's cockpit in each side of the fuselage; airfoil-like extension of the lower wing leading edge between fuselage and inboard interplane struts; automatic full span flap on the lower wing. The 14A.2 generally had none of these identifying characteristics but carried the word "Photo" at the pilot's cockpit on either side.

Because parts of these two designations were interchangeable, some B types had no flaps, some A types did; some A's were converted B's and possessed fuselage windows, and so forth. Balanced and non-balanced ailerons also were variously fitted to both types. And type A, in accordance with requirements for all other single engine planes in this class, carried fittings for attachment of bomb racks with a capacity of four small bombs.

Construction

Briefly, the Breguet 14 was of mixed wood and metal construction, each material being used where its designer thought it (1) would give the best service, and (2) would be most adaptable to high production methods.

The fuselage was framed principally of aluminum with wood or steel reinforcements as required. Longerons were tubular aluminum. Uprights and crossbraces of the same material were attached by means of welded steel tube sleeves riveted to the components. Steel wire was used to brace the structure.

Engine bearers were made of U channelled aluminum supported by aluminum and steel struts. The nose radiator, pierced for the propeller shaft, was attached to the bearers and to special extensions of the lower longerons.

The husky landing gear consisted of three pairs of struts of aluminum tubing drawn to streamline shape, each internally reinforced by a full length of channelled steel riveted in place. Upper end of each strut was attached to the longerons on each side by means of steel stampings. Strut lower ends fastened to right and left horizontal steel members which carried the axle. The landing gear assembly was wire-braced and equipped with rubber cord shock absorbers.

Breguet tailskids were made of ash, covered with aluminum sheet, and sprung from rubber shock cord. Additional shock absorbing was provided by steel leaf springs on the skid tip and a vertical coil spring of the "oleo" type set inside the tubular fuselage sternpost.

The fuselage was covered in front with well louvered removable side and bottom panels. The upper cowl, also removable, covered the top of the engine and was provided with an opening for installation of an overhead exhaust collector. Sheet aluminum served as the top fuselage fairing to the rear of the gunner's cockpit. From there to the tail—both top and bottom—a built up wood and metal fairing, covered with fabric, was provided. The fuselage otherwise was fabric covered.

Engines fitted in the Breguet model 14 varied with the type and are specified in the comparison table accompanying this article.

Two gravity fuel tanks of 130 litres each, located behind the motor, and an 18 litre oil tank mounted on the right side fed the engine. Exact placement of these reservoirs varied slightly in some instances, but the allowable fuel load for any type in the 14 series was 475 lbs. This was sufficient for about 2½ hours full throttle operation at sea level. Each fuel tank was fitted with an individual, electrically operated float type indicator which was actuated by pressing a button on the instrument panel. Electricity for the fuel gages was supplied by a small dry cell battery.

The instrument panel, protected on all new models by a large sheet of framed Triplex safety glass (some pilots removed this glass to save the weight) contained a tachometer, watch, altimeter, compass and water temperature indicator. On the pilot's right were the radiator shutter control lever, starting magneto, engine priming pump, oil and fuel petcocks and cockpit lighting and radio fittings. On his left were the throttle and spark levers, air pump regulator, magneto switch and fuel shut-off valve control.

The observer was provided with a seat so hinged that he could sit either high in the fuselage (flying to an objective) or low on the bottom (for bomb aiming in model 12B.2, camera sighting in model 14A.2). The windows in the fuselage sides gave the bomber-observer a view of what was going on outside when he was busy with the mounted bombsight. Bomb release levers were located on the observer's right; to his left were a throttle control and magneto switch. Dual flying controls were fitted, those in the observer's cockpit being removable.

Many Breguet model 14s, both A and B, were equipped for night flying and had position lights fitted to their outer inter-

plane struts. These were controllable from the observer's cockpit along with the radio installation, if any. Power for radio and position lights was supplied by a wind driven dynamo mounted below the fuselage.

Armament on all models included one fixed, synchronized machine gun mounted on the left side of the fuselage and operated by the pilot. The observer's armament was either one or two machine guns—usually the latter—mounted on a tourelle surrounding his cockpit.

Further description of the Breguet model 14 and an analysis of flight surfaces, performance figures and flight characteristics will be presented next month.

TYPE	Engine	HP	Span, feet	Area, Sq. ft.	Length, feet	Weight empty pounds	Weight loaded pounds
14A.2	Renault 12 FCX	300	47.12	580	29.58	2222	3380
14A.2	Renault 12 FCY	310	46.00	528	29.22	2222	3380
14A.2	FIAT A12	285	46.00	528	29.31	2288	3447
14A.2	FIAT A12	275	46.00	528	29.2	2200	3396
14A.2	Lorraine 12D	370	47.12	560	29.58	2310	3144
14A.2	Renault 12K	400	46.00	528	29.2	2640	4090
14B.2	Renault 12 FCX	300	46.00	560	29.2	2280	3880

The Ancient Glow-Plug

(Continued from page 19)

of the glo-plug in model airplane engine design is an ingenious application of an old proven device, and where results count it behooves the user to consider the factors which, theoretically at least, should produce the best results.

In its connection with model airplane history the glo-plug has a little to offer, too. Way back in 1908 Ray Arden, designer of the present type of Arden glo-plug, developed and used a glo-plug in a model engine. It seems a long time from 1908 to 1948 but recently the story came out.

A year or two ago Ed Chamberlain came up with a novel approach to the same problem. He developed a fuel called *Liquid Dynamite*, which in effect turns the sparkplug into a glo-plug. This special fuel is used in the conventional manner, aided by the regular ignition system for starting purposes; but after the engine reaches a good heat the sparkplug points come to a glow, and the ignition system may be disconnected. Moving the timer arm then has no affect on engine operation.

For two years, Art Hasselbach has been experimenting with sparkplugs (Fig. 1) converted to glo-plugs for use with this *Liquid Dynamite*. The *H & H* engine—which was developed just before the war and has been on sale for the past 18 months—is the first commercially-produced engine designed for use with the glo-plug.

The model airplane engine in its two cycle form is accepted as the best for its purpose because of its simplicity and lightness. Few moving parts give it both of these desirable qualities. Because of the rapid firing action of the two cycle engine, any slight disarrangement of the ignition system causes it to fail. But failure will also result from any other dislocation. Therefore, by merely inserting a glo-plug one may or may not get good results. The supporting factors such as: type of fuel, fuel-air mixture, correct compression ratio, proper port timing, and precise mechanical fits, are vital to good operation. Removal of waste products, or

NOTHING ELSE TO BUY • JUST BUILD AND FLY

\$9.95

POSTPAID

25 BIG GAS ITEMS

**"THE LANCER"
CLASS A-B-C
24" WINGSPAN**

MOTOR
'Genie' or 'Denny'

- Lancer U-Control
- \$2.50 Ign. Coil
- Condenser Prop.
- Ign. Wire • Lugs
- Sullivan Control Wire
- Rubber Wheels
- Manual on Control Flying
- Identification Tags
- Catalog • Cement
- Dope • Nuts • Bolts
- SAE 70 Oil
- Booklet on Engines
- Motor Hints Chart
- Packing & Postage
- Hi Tension Lead
- Spark Plug
- Batteries
- Control Handle
- Full Size Plans
- Skyway Knife

LINE CONTROL

New type construction. Just 4 solid halsa planks for body and wings. All parts printed or semi-cut. Complete with full-size plans, rubber wheels, control handle. Kit alone \$3.95 P.P.

\$12
P.P.

DELUXE OUTFIT
INCLUDING
ALL 25 ITEMS AND
OHLSSON '23' or '19'

YOUR CHOICE

Of Either Motor with \$9.95 Outfit
Class 'B' GENIE-29 or Class 'C' DENNYMITE
Motor alone \$6.95 P.P.

20 ITEMS FREE WITH GAS MOTORS

<ul style="list-style-type: none"> • 3 Ps Wrench Set • Ign. Wire • Nuts • Coil • Condenser • Lead • Mounting Bolts • Lugs • Booklet on Motor Repair • Steel Ruler • Metal Pliers • Plastic Handle Screw Driver • Ident. Tags • New Catalog • Postage and Insurance • 100ft Control Wire • Batteries 	<ul style="list-style-type: none"> Arden .099 P.B. \$12.50 Arden .039 B.B. 15.50 Arden .199 B.B. 18.50 Atom .099 15.50 Bantam .199 15.00 Thor-B Kit 6.95 Ohlsson 19 9.95 Ohlsson 23 9.95 De Long 30 19.50 	<ul style="list-style-type: none"> Ballet .275 \$ 9.00 Thor 30 9.95 Pierce 29 'R' 12.95 Ohlsson 60 11.95 Dennymite 57 6.95 Mohawk 'B' 8.95 Hornet 22.75 McCoy 26.00 McCoy 49 25.00 	<ul style="list-style-type: none"> Madewell 49 \$12.50 New Pierce 'B' 9.95 Super Cyclone S.I. 18.00 Super Cyclone D.I. 19.00 McCoy '29' 19.50 Mite Diesel 12.50 Drone Diesel 14.95 Foster 29 19.50 Deezil 'A' 12.95
---	--	---	--

MERCURY MODEL AIRPLANE CO.

920-N4 UTICA AVE. BROOKLYN 33, N. Y.

SEND 3c STAMP FOR CATALOG & FREE Motor Hints Chart.

NOW!! --- NEW!!

The ATWOOD "GLO-DEVIL"

Specifically Designed & Engineered for Glo-Type Ignition

\$15.00

(LESS IGNITION PLUG)

.60 Displacement
AMA Class D
For Control Line & Free Flight
No Ignition Coil, Condenser, Breaker Points or Flight Batteries!! Save Money!! Save Weight!!
Improve Performance !!

Ask Your Dealer for a demonstration.
AND—If you want to convert it to conventional breaker-point ignition simply add timer accessory.

For Those Who Demand The Ultimate In Conventional Ignition Engines

The ATWOOD "SUPER CHAMPION"

\$17.50 at your dealers

The National Stunt Champion

All Atwood Engines are Fully Tested and Fully Guaranteed

ATWOOD MANUFACTURING CO., 147 Pasadena Ave., So. Pasadena, Calif.

**D-E
PRECISION - BUILT
ACCESSORIES**

NEW!



D-E

**Fuel Shut-Off
Valve**

\$1.00

(PATENT
PENDING)

**Automatically and instantly shuts
off fuel on any model engine**

It stops your engine, whether it is Diesel, Semi-Diesel (glow plug) or full ignition operated. It stops it the right way—not by flooding the engine but by stopping the flow of fuel.

The only shut-off valve that operates on all engines from .09 to .65 displacement.

Jim Noonan, Model Airplane News Diesel Expert says: "Explodes previous diesel theory. By my tests, it is fastest, most powerful of 45 diesels from all over the world."

**Variable Compression
D-E Arden
Diesel Conversion**

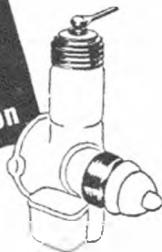

Convert your Arden to an ignitionless Diesel in a few minutes. The D-E Diesel Head gives super power plus easy starting. Complete instructions and information on Diesel Operation are included with each conversion kit.

**D-E Diesel Conversion
for Arden .099.....\$3.00**

**D-E Diesel Conversion
for Arden .199.....\$3.50**

**OPERATES GLOW-PLUG
ENGINES TOO!**



**D-E
DIESEL FUEL**

The most powerful diesel fuel available. For use with any variable compression diesel.

**85c
Pint**

Mail Orders: 3 cans \$2.50
Shipped Express Collect
Dealer Carton: 24 cans

If Your Local Hobby Dealer Does Not Stock D-E Products, Order Direct Giving His Name.

**Berkeley Model Supplies—N.Y.
140 Greenpoint Ave.—Brooklyn 22 N.Y.**

exhaust, must also be taken into account.

Since the manufacturers provide the features for proper operation of their engines, and recommend fuels, mixtures and handling procedures, the engine user himself must check the unknown factors when attempting glo-plug adaptation. The manufacturers who sell engines equipped with a glo-plug can do so because they have found the best combination of fuel, compression ratio, and construction for their particular products. However, all engines may be adapted for glo-plug use.

Fuel is a delicate matter and it is usually found that where a certain fuel is prescribed that fuel will give good results. When a strange fuel is used the results may very well be poor running or complete failure. This may not be the fault of the fuel itself. No two fuel-air mixtures have the same combustion point. The combustion point is that degree of temperature at which the mixture will ignite. In an engine utilizing the glo-plug, this combustion point may be regulated somewhat. The range of regulation possible depends on the allowances left in the engine to change the compression ratio, since the latter (explained below) is the factor which determines the heat of the mixture as it goes into its preparatory stages before ignition and combustion.

In a diesel where there is no ignition aid such as a glo-plug, all the heat necessary for ignition and combustion is generated by compression alone. Forcing a quantity of fuel and air into a greatly decreased area will cause the compressed vapor to generate heat. This system of utilizing only the heat of high compression for ignition gives rise to the term compression ignition engine. In a spark ignition engine, where a timed electrical spark sets off the fuel charge, high compression ratios are not of primary importance because the spark does this job.

The glo-plug, since it does not give a timed spark, makes use of the compression ratio as a primary heat source obvious. As stated above, no two fuel-air mixtures have the same combustion point, and neither is it certain that two engines with the same compression ratio will be alike. The heat generated depends on heat losses through the walls of the engine and possible leakage through ports or poor fitting of parts.

A spark ignition engine operates in the range of compression ratios between 7 and 10 to 1, while the compression ignition engine utilizes ratios of between 12 and 22 to 1. By addition of a glo-plug we find that the compression ratios need be less than those last mentioned. To emphasize, those engines which are manufactured for use with a glo-plug take all these points into consideration; the proper compression ratios are built in and usually a special fuel mixture is recommended. The reasoning is obvious. Best results are obtained because the fuel, the ratio, and the glo-plug all combine to assure complete combustion.

Difficulties are apt to arise when new fuels are tried because the new fuel-air mixture may not have the same combustion point. To attain proper results, the compression ratio would have to be changed. Before attempting such alterations, the original compression ratio should be known; we will show how to determine this. But first, to accentuate the importance of these ratios study the table below. It demonstrates the critical compression ratios of selected fuels. (Critical compression ratio means that ratio from which maximum power delivery in compression ignition engines may be attained.)

A NEW LINE OF SOLID MODELS!



3/4" Scale for greater detail and ease in carving

Jimmie Donittle "Gee Bee".....	\$0.75
Art Chester "Jeep" Racer.....	.75
Frank Hawks Mystery Ship Texaco "13".....	.75
Weddell Williams' Racer—Roscoe Turner's "57".....	.80
Pesco Special Racer.....	.60
Heward "Pete" Racer.....	.50

Scale Plastic decals for a better finish. Detailed plans—full instructions. All balsa cut to outline shape. AT YOUR DEALERS.

TUTTLE BROS. MFG. CO.

330 N. E. 16th Ave., Phone Vermont 5273, Portland 14, Oregon

HAVE YOU TRIED LEADER ACCESSORIES?



Rubber Tired Wheels With Aluminum hubs 1/2" to 1-5/16" Dia. 15c a pr. to 20c ea.
6 oz. Fuel Pump Bottles.....75c
Flex Shaft Needle Valve extensions.....35c
(Strait Shaft).....25c
Bell Cranks.....15c
Elevator Adjustment.....25c
Prop Nuts 1/2" & 5/16".....5c
Universal prop Washers.....5c
Wheel Collar Hubs, Set.....25c
Wheel Collar, pr.....15c
Copper Gas Line 6".....10c
Slide Switch a.p.s.t.....25c
Flex Cable—3-ft. coil.....10c
Brass Flywheels
"A" \$1. "B" \$1.75. "C" \$2.00

SEE YOUR LOCAL DEALER

LEADER MODEL SUPPLY CO.

6539 S. Ashland Ave., Chicago 36, Ill.

LANSKO

Model Airplane Merchandise at Standard Prices
OWNED AND OPERATED BY AN ACTIVE MODEL
BUILDER

Mail Order Service 36 Years Same Location

6 2-OZ. BOTTLES CEMENT \$1.10 postpaid

MOTORS	U-CONTROL KITS
Arden Glow Plug.....\$.85	A. J. Fireball.....\$7.95
Glow Plug Adaptor......25	Overpass.....4.95
Arden .099 P1'n Br.....12.50	Custom Champ.....3.95
Arden .099 Ball Br.....15.50	Oreansy Jr.....3.95
Arden .199 Ball Br.....18.50	Beechcraft "Bonanza".....7.50
McCoy "29".....19.50	"Lil' Zileh".....2.95
McCoy "49".....25.00	Junior Cruiser Deluxe.....5.95
McCoy "60".....27.50	"Super-Zileh".....4.95
Forster "29".....14.85	California "Skeeter".....3.95
Super-Cyclone.....18.95	Goldberg's "Zing".....4.95
Ohlsson "19" & "23".....9.95	
Ohlsson "60".....11.95	
O.K. "Hothead".....12.50	
Atwood "Glo-Devil".....15.00	
Atwood	
Superchampion.....17.50	
OK's CO-2.....4.95	
K & B "24".....16.50	

**RUBBER POWERED
MODELS**

Gollywook.....\$1.25
Comet Gull.....1.25
Jasco "Sport".....1.50
Interstate Cadet.....1.50
Flying Cloud.....1.50
Stinson L-6.....1.50
Bummeier "30".....1.00

And many others. Write for price list. Motors postpaid and insured in U.S.A. Free postage and packing in U.S.A. Mail orders to—

**LANSKO MODEL AIRCRAFT
SOUTH HAVEN, KANSAS**

FUEL	RATIO
Nitro-Methane	5 or 6 to 1
Kerosene	7½ to 1
Light Diesel Fuel.....	8 to 1
Heavy Diesel Fuel.....	10.6 to 1
60 Octane Gasoline.....	11.1 to 1
80 Octane Gasoline.....	14.2 to 1

The range of ratios is wide, and when using a glo-plug where the owner desires to try various fuels, consideration must be given to the fuel and its close relative, the compression ratio. Keep in mind that the glo-plug equipped unit is not a spark ignition engine, and cannot be treated as such.

Nitro-methane, a commercial solvent used extensively for film processing, is the most common accelerator used to date. Proportions of a successful fuel are: 1 part nitro-methane, 2 parts methol alcohol, 2 parts bakers AAA castor oil.

Two dimensions are usually stated when describing an engine: bore and stroke. Bore is the diameter of the cylinder into which the piston fits. Stroke is the distance the piston travels from the lowest point in the cylinder to the highest point. The dimensions used here are purely hypothetical and have no relation to any engine which may have these dimensions. Let's take an engine with bore .500 and stroke .750. (For those not familiar with these measurements, they represent 500 thousandths of an inch and 750 thousandths of an inch respectively.) The figures we need next are the volume of the cylinder and the volume of that space which is between the underside of the cylinder head and the piston top when the piston is at its highest point in the cylinder.

To determine the volume of a cylinder the mathematical formula is: 3.1416 x diameter (bore) squared, divided by 4. This figure is then multiplied by the stroke and the result is the volume of space with the piston at its downmost position. To simplify we can divide 3.1416 by 4 and use this formula: .7854 x .500 x .500 x .750. This gives us .1472625 from which we may drop the last four figures as they are insignificant. We have now the volume of the space swept by the piston: .147 cubic inch. Next we determine the volume of the space between the piston at top position and the underside of the cylinder head. The diameter (bore) is the same for this determination. Assume that the height of this space is .050 or fifty thousandths of an inch. The same formula is used thus: .7854 x .500 x .500 x .050 and the answer is .0098175 which we will call .010 for simplicity.

Adding these two volume figures we have: .147 cu. in. (volume of piston displacement) plus .010 cu. in. (volume of clearance space) equals .157 cu. in., total volume of the entire cylinder. The compression ratio is the relationship between this total volume and the volume of the clearance space when the piston is at its topmost position. Dividing the volume of the clearance space into the total volume, the answer is of course 15.7. Hence the compression ratio of our hypothetical engine is 15.7 to 1. Knowing the two dimensions, bore and stroke, application of the above formula will give the compression ratio of any engine.

In the above case the charge of fuel and air is compressed into a space which is about 1/16 the original space occupied, and great pressure is reached, which heats the charge. The glo-plug here performs its function by igniting the highly compressed charge as the charge is brought up to its point of ignition. Com-

NEW McCOY ENGINE SERIES 20

NEW LOWER PRICE

NEW SPEED & POWER

**WORLD SPEED RECORD
BROKEN FIVE TIMES**

IMRCA—Los Angeles—
Nov. 30, 1947
Manufacturers' Proto Class

	MPH
Joe Robertson and James Persons, San Leandro	120.00
Roy Torrey, San Dimas	117.95
Dick McCoy, Pomona	117.95
Mrs. Fred Brock, Santa Ana	116.12
Don Sharver, Santa Monica	112.92

All with Invader cars and
McCoy 60 engines

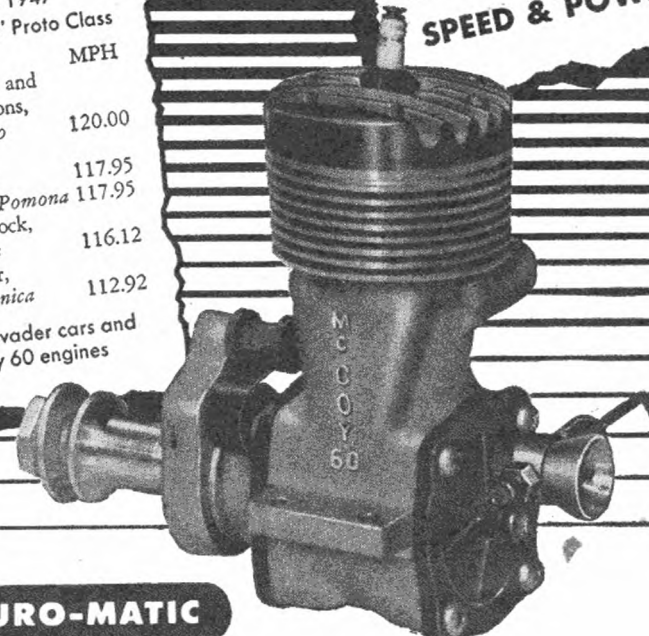

DURO-MATIC

Red Head "60" SERIES 20

Designed by Dick McCoy

Want a winner? Here's your engine . . . brand new and raring to go . . . the hottest Red Head in a complete line of McCoy contest engines. The new improved McCoy "60" follows precision standards of other famous Red Heads (49, 29 and original 60). It is built to win . . . to set records . . . to show its heels to the competition in all events. It is built to make you kingpin of your contest.

Here it is - more engine at this price than has ever been offered before.

FEATURES

\$27⁵⁰

2 MRC precision ground ball bearings

2 Perfect Circle piston rings

Tungsten automotive type points

Displacement, .60 cu. in.

Max. RPM, 20,000 plus

Machined surfaces, metal to metal fit, no gaskets

VR2 Champion racing plug

Weight, 12 oz.

Over 1 HP at 15,000 RPM

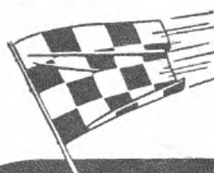

Buy it at your hobby dealer

Checkered Flag Line
DURO-MATIC PRODUCTS COMPANY
HOLLYWOOD 38, CALIFORNIA

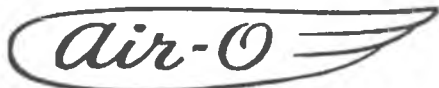

NEW 1948 MODEL *G-P MIGHTY MIDGET

*Glow Plug Mighty Midget designed by Ray Acord to fly with ANY alcohol base fuel.

\$14.75
LESS PLUG

FOR **FREE FLIGHT**

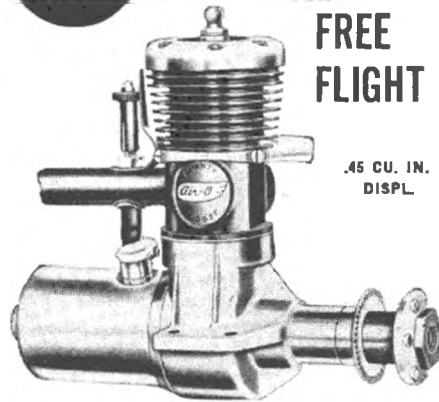

.45 CU. IN. DISPL.

With the coming new A.M.A. rules look to the G-P Mighty Midget for the undisputed champion class "C" free-flight engine.

- Light weight, 7 oz. bare.
- More power. Rated .6 H.P. at 12,400 R.P.M.
- 10,000 R.P.M. with 12" propeller.
- Only class "C" engine especially designed for free-flight using piston rings.
- Steel piston and cylinder. Glo-plug or hot fuel operation will not pound out steel piston with piston rings. The Mighty Midget can really take it!
- Larger crankpin bearing for G-P operation.
- Bunting bronze main bearing.
- Flight-tested. Not critical with any alcohol base fuel on the market.

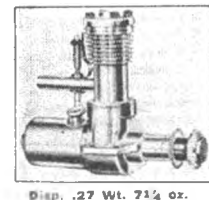

AIR-O DIESEL

Powerful, easy starting with adjustable compression. The perfect power-plant for the Thimble-drome race car. Speeds of 50 m.p.h. with direct-drive. **\$16.50**

Special cast engine mount for Diesel-Thimble-drome **\$1.00**

Disp. .27 Wt. 7 1/4 oz.

AIR-O PROPS

FOR HIGHER CLIMB
FOR SPEED OR STUNTS
IT CAN'T BE BEAT!

TRY IT!



NOTE! The winning prop for over 5 yrs. The experts' standard. Don't use imitations—insist on the AIR-O Trade-mark.

- Each prop carefully hand-sanded and balanced.
- Made from fine, select hard wood.
- Finished with 4 coats clear lacquer.
- Perfect airfoil section—true pitch.
- Correct blade area.

AVAILABLE NOW AT NEW LOW PRICES!

AIR-O FREEFLIGHT 'AIR-O-LINE' U-CONTROL
8"-9"-10" Diam. \$.50 ea. 8"-9"-10" and
11"-12"-13" Diam. .60 ea. 11" Diameter ... \$.60 ea.
NEW CO. PROPS 7" or 8" Diam. \$.35 ea.

AIR-O ENGINE MOUNT

THE FINEST ENGINE MOUNTS ON THE MARKET

- Made from fully annealed steel.
- Light weight.
- Heat-treated after forming to relieve stress lines.
- Finished in beautiful black oxide.
- Front hole drilled, assures engine alignment.

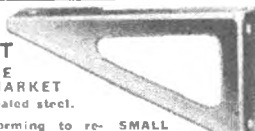

SMALL for Class A and B \$.40
LARGE for Class C and D \$.50

Air-O MODEL SUPPLY COMPANY
741 NORTH PRAIRIE AVENUE
HAWTHORNE, CALIFORNIA

FACTORY REPAIR SERVICE: ALL MIGHTY MIDGET, COBRA, TIGER, AIR-O DIESEL ENGINES.

bustion starts and the engine operates. The gases released by combustion expand and the piston on its way down opens the exhaust ports, the burnt gases are expelled, a new fresh charge is brought in and the process repeats itself. The glo-plug, by retaining some of the heat generated by the explosion remains incandescent and aids the next cycle of operation.

In order to adjust the compression ratio of an engine so that a glo-plug can be used to best advantage, the ratio between clearance space and total volume of the cylinder must be varied. To raise the ratio, the cylinder head must be lowered. This is accomplished by removing metal from the head flange or from the top of the cylinder barrel to diminish the total distance. In fact, any operation that lowers the cylinder head in relation to the piston top will do the job. In any case no more than .010" thickness should be removed. Taking more than this may seriously affect the port timing of your engine. Take care when lowering the head, to allow enough clearance for the glo-plug; the piston at its highest point must have no obstruction.

To lower the compression ratio the head must be raised. The effect will be to increase the volume of the clearance space, and this is accomplished by placing gaskets between the head and the cylinder barrel. By knowing the thickness of the gaskets, the new ratio can be computed.

The engine owner must realize that an engine can be changed only insofar as the construction of his particular engine will permit. Some engines with thick cylinder heads may permit the removal of sufficient material to accommodate any baffle on the piston itself. In all such conversion work, however, the parts must remain true fitting to prevent pressure losses. Any leakage due to a bad fit, or for any other reason, will reduce the actual compression ratio; while the mathematical ratio in such case might be correct, it is the actual pressure achieved that is important. Mathematical formulas can only determine the ratio, never produce it.

Use of the glo-plug opens a wide field of heretofore unexplored territory. The possibilities for exceeding present day performance may well come from the combination of fuels, compression ratios, and mechanical perfection which, with the use of the glo-plug, will utilize the greatest percentage of power given up by combustion. The trend of new developments in engines toward greater lightness and speed can be traced from the spark ignition to the diesel, and now to the glo-plug. All of these and their many variations promise more for the future development of the ultimate in model airplane engine design. No development is insignificant, and who knows by what happy coordination of features some modeller may come upon the most progressive power unit the model airplane engine field has ever seen.

The writer would appreciate any comment on tests made utilizing the glo-plug, no matter if the engine is one converted for its use or one manufactured with the glo-plug as an integral part. It is suggested that all data be put in writing so comparisons may be made. Fuel and mixture, compression ratio, starting characteristics, port timing, etc.; all of these, as well as visual manifestations, should be noted and by comparing results more accurate information will be obtained. Address all correspondence care of MODEL AIRPLANE NEWS.

ANNOUNCEMENT NOW YOU CAN OWN A

DRONE

DIESEL \$14.95
(Was \$21.50) for only

America's first—America's finest diesel is now available at this low price, at all dealers!

Drone Champion 'Mates':

KITS	SECRET WEAPON	\$3.95
	DRONETTE	3.50
	HOT ROCK	3.95
	Engine Speed Control & Free Flite Attach.....	\$2.00
	New 'VC' Variable Compression Head.....	3.50
	New Glow Head.....	2.25
	New 'Drone' Prop.....	.50
	and that fine DRONE DIESEL FUEL	Qt. 1.00

DRONE ENGINEERING, INC.

1163 E. Broad St., Elizabeth, N.J.
DEALERS: DRONE IS 1st in SALES!

WHY SUFFER?

You Can Laugh While Learning!!!

AIRPLANE WEIGHT AND BALANCE MANUAL

Original, humorously written, complete, no "big" words, 16 drawings, 11 formulas

Very simplified, starts with necessary arithmetic: teaches moments, weighing procedure, C.G. calculations, ballasting methods, alteration systems, etc.

Each basic airplane balance problem explained and worked out in detail, step by step, easily understood by home study. Method and knowledge can be used on landplanes, seaplanes, models, any object.

Revised Edition of **"THE ELUSIVE SEE-GEE CRITTER"**

Erupted by John W. Herrick
Years of experience, practical engineer, mechanic, teacher

Postpaid in U.S. for \$1.00 or sent C.O.D.

MERRYSTUDY PUBLICATIONS
Box H, LaFayette, N.Y.

PRECISION JEWELERS SCREW DRIVERS

Complete Set of 8 for Every "Hobbyist"



At last—a complete set of precision screw drivers to meet the needs of every model builder. Not a miniature but the same type set used by U.S. Navy for precision instruments and watches during the war. Brass knurled handles, hexagon heads, finest tempered steel blades. Sizes 2-9. Never before a set of this quality and precision at such a low price. Your money back if not satisfied. C.O.D. \$2.00 plus postage or send \$2.00 and we pay postage.

PINE WATCH CO.

Rm. 40M, 29 Eldridge St., N. Y. 2, N. Y.

Plane on the Cover

(Continued from page 15)

the reciprocating engine ship. Yet it is at low speeds that an airplane needs the greatest power for acceleration in getting the ship in motion quickly.

When a turbojet engine is "run up" on the ground, its big compressor creates a powerful "suction" through the air intake that cannot be accommodated by the surrounding air. Therefore, this creates such a tremendous vacuum in the intake that it has been known to crush the internal ducts. The basic jet fighter problem, as these Grumman engineers saw it, was to provide some means for admitting extra air into the engine while the airplane was moving at a very slow speed. And the answer was "blowing doors", small panels along the upper rear portion of the fuselage near the engine compressor which (1) reduce the vacuum inside the engine chamber thereby relieving the strain on the duct walls, and (2) provide plenty of air for the engine to "breathe" at low speeds. By this comparatively simple device, Grumman appears to have solved the heretofore tough problem of operating a jet fighter aboard a carrier.

As a result, the XF9F-2 Panther needs only 450-650 ft. (depending on the speed of the carrier) to get off the deck and into the air, while the Lockheed P-80 Shooting Star requires about 4000 ft. of runway to get airborne! In addition, when the Panther makes its final approach to the carrier deck and receives a "wave-off" from the Landing Signal Officer, the pilot can "pour the coal" to the engine without hesitation and the resulting surge of power will carry him up and around promptly and safely without the laborious (and dangerous) delay of many other jet types.

With this problem solved, the Grumman design team set to work on the routine problem of designing a fast, maneuverable fighter of simple, easily-produced structure and comfort, vision and safety for the pilot. But this "routine" job was not executed in a routine manner. For the team next took up the question of landing a very "hot" fighter slowly and safely. This is simply a question of lift coefficient, a product of wing shape, airplane attitude, and speed. Since it requires a low lift coefficient to go fast and a high lift coefficient to go slowly, engineers have compromised in the past with both extremes, the resulting product going neither as fast nor as slowly as possible.

Grumman engineers solved this problem by producing a changeable wing profile, one that was straight and smooth for high speed and curved for low speed. This was accomplished by fitting "nose flaps" to the NACA high-speed wing. These nose flaps move forward and down while the trailing edge flaps are moving back and down: producing a high-cambered airfoil with an extremely high lift coefficient in the extended position. As a result, the Panther can slow to 50 mph when "coming aboard" a carrier steaming into the wind, resulting in short landing run and reduced loads on the structure when the deck arrester gear engages.

Another problem, which was not so easily solved, was tailpipe length. The length of the jet tailpipe behind a turbojet engine is of critical importance. It must be long enough to permit the exhaust gases to recover their pressure lost through acceleration yet short enough to minimize the effect of energy losses in the duct. Grumman engineers decided

FOR AMA CONTESTS-RED HEAD ENGINE

THE FAMOUS MINIATURE JET-GASOLINE ENGINE

DYNA-JET

THE ULTIMATE IN ENGINES!



PAT. PENDING

RACING ENGINE

SET THE RECORDS WITH DYNA-JET! AMA INTRODUCES JET SPEED EVENTS for 1948 Contests!

As a result of overwhelming demand by modelers a Jet Speed Class is included in 1948 under Academy of Model Aeronautics Rules.

DYNA-JET ALSO ELIGIBLE FOR STUNT AND FLYING SCALE EVENTS

FOR MORE SPORT and LESS SWEAT FLY DYNA-JET!

Don't forget that Dyna-Jet's ease of starting, simplicity, reliability, and power make it ideal for stunt and flying scale models.

4 1/4 lb. Static Thrust Equal to 2 Hp. plus!

Exerts at 125 mph with 70% "Prop" efficiency

No Ignition System to burden your model

No Propellers to Break

No Special Fuels runs best on gasoline

Not Weather Sensitive forget humidity changes

The BEST ENGINE and the LEAST EXPENSIVE

It Will Not Wear Out!

Runs as well 5 years from now as it does today. You save on engine life, trade-in value, and propellers.

Your most economical buy.

\$35.00 If dealer can't supply, order direct. Prompt Delivery.

GUARANTEED

1. To start easily with hand tire pump.
2. To equal or exceed advertised power.
3. Against defects in material and workmanship.



Dyna-Jet SPEEDSTER

Flight tested, control line model. Complete plans FREE with each engine. Plans only — 30c in stamps.

AEROMARINE COMPANY
Dayton Municipal Airport
Vandalia, Ohio

It's the MIDJET, fellows! Midget Type JET RACER MONOGRAM'S LATEST JET SENSATION!

Here's another addition to your JET POWER FUN by the creators of the original jet racer. Get this new kit from your favorite store today. Fully shaped body with axle holes, metal axles and bushings, rubber wheels, plastic steering wheel and windshield, wire for bumper guards, decals. A truly complete kit! If no dealer near you include 15c extra for shipment

Assemble and Get it Rolling in FIVE MINUTES

Extra time required for painting and details, of course. Completely shaped balsa body with Monogram front end, axle holes, and bored for jet cartridge, makes assembly easy.

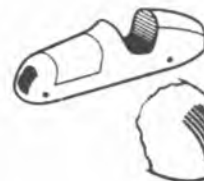

Fully Shaped Body

Monogram Front End

Kit R-4
85c

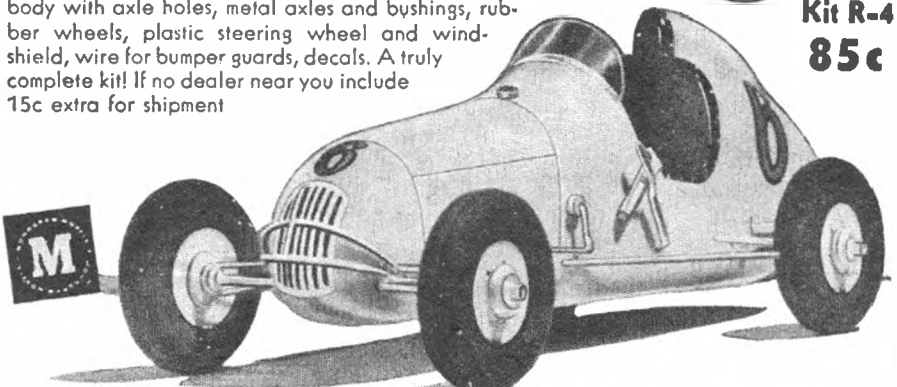

MONO-JET Ask your dealer to show you the new Mono-Jet too. Monogram's sensational Indianapolis-Type Jet Racer. Kit R-3 . . . 85c.

MONOGRAM MODELS, INC., 2329 S. Michigan Ave., Chicago

Dealers are roaring for the **KRAMER "lion" SOL.**



Sure, **LOU!** They know that our pre-tested items always take it on the "lamb"



DEALERS:

If you want to keep abreast of everything new in the industry, write in for "The Kramer Krier." It's FREE!



For strong, steady selling, you can't beat our "pre-tested" items. And here's another sales-winning combination—complete stock plus plenty fast delivery! So find out for yourself—today!

Dealers, Write Us Your Needs

KRAMER BROTHERS INC.
MODEL DISTRIBUTORS
125-27-29-31 Colvin St., Baltimore 2, Md.

GREAT GUNS



Fizz Gun

FOR PUNCTURING CO. TANK
Has double-nut adjustment for accurate control of size of hole. Solid brass, knurled for easy handling..... **50c**



Glue Gun

Here's a tool that puts a daub of cement just where you want it—right corners, edges, under fuselage, etc. Handy! All metal..... **75c**



Needle Valve

New Flex Needle Valve with double acting ratchet and spring for finer tuning and precision adjustment..... **\$1.00**



4-socket Plug Wrench

New design for easy handling. Fits all plugs. **50c**

PRICES SUBJECT TO CHANGE WITHOUT NOTICE
See Your Dealer—We Pay All Postage

AUSTIN-Craft 431 S. Victory Blvd
Burbank, California

ART HASSELBACH
says:



These Flying Solids were the sensation of the National Hobby Crafts & Science Show at Madison Square Garden, Nov. 23-30. Word of this new development spread like lightning and we have been deluged with inquiries. Flying Solids offer thrilling speed flying fun every day, rain or shine—all year 'round. Order yours immediately and get in on this latest flying spree.



NEW! FLYING SOLIDS!
JET SCALE SOLIDS THAT FLY OVER 100 MPH
CHOICE OF MODELS

P-47	Hawker Typhoon	Jap Zero
P-51	Grumman Hellcat	FW-190

KIT SPEC: Complete Red-Carved 3/4" scale solid kit PLUS jet rack parts, full size plan of jet installation and complete information on "How to Run Jet Flying Solid Contests." **ONLY \$1.49**

plus 25¢ shipping. On 2 kits or more, we pay shipping.



3087 THIRD AVENUE NEW YORK 56, NEW YORK

that the latter problem was of greater importance than the former and fixed the optimum tailpipe length far short of the tail of the airplane, giving the Panther its peculiar "soup ladle" appearance at the tail.

One other design problem was adequate power. The engineers were aware that high speed is basically a question of power and no U.S. turbojet engine offered the power required for the new design. So Grumman went abroad for the potent Rolls-Royce *Nene* turbojet engine that is rated at 5000 lbs. of thrust (dry) and nearly 6000 lbs. of thrust using water injection. Two engines were imported for experimental use in 2 of the 3 prototype Panther fighters. In the meantime, the Navy Department made arrangements for establishing an American producer of this powerful engine and signed a contract with Pratt & Whitney Division, United Aircraft Corp. to produce the *Nene* in quantity. As a further safeguard to insure power for the Panther, the Navy contracted with Allison Division, General Motors Corp., for recently-improved Model 400 engines, which are eventually slated to attain the output of the British model. The third prototype KF9F-2 will be powered by this new Allison engine. Production quantities will alternate between the two engines, creating the first U.S. jet airplane capable of using either of two engines.

Proof that Grumman engineers have produced another winning design is the award of a contract for constructing 100 Panther fighters before Corwin "Corky" Meyers had even put the new craft through its initial paces. (The first flight, incidentally, ended on the runway at still-uncompleted Idlewild Airport, where Corky knew there was adequate runway length. Following the landing he took the Panther aloft from Idlewild, thereby "breaking in" the magnificent new project as a secret test base before it assumes its more prosaic duties as an airline base next July.)

Performance figures on the new Panther are not available simply because neither Grumman nor the Navy know them: The plane is still so new that it hasn't been flown over carefully calibrated courses, nor its instruments checked for accuracy. But you can bet it will crowd the 650 mph mark when it does race over the Naval Air Station course at Patuxent shortly. And it will top the 45,000 ft. altitude mark by a considerable margin.

Grumman is already forming an F9F production line and building the special dies, fixtures and jigs for its production. During this year the Navy expects to get only one dozen F9F's, and a total of 89 next year, but that 100-order is only the beginning of the Navy's plans for the speedster. They've already prepared schedules for eventual quantities of 200-300-500 Panther fighters, the exact number of which will depend on Congress and how well the Navy can convince them that in the new Grumman F9F Panther fighter this nation has the world's best carrier jet fighter. Personally, we're already convinced!

New WYLAM Series!

A new series of Bill Wylam's superb Masterplans on the PFALZ D12, German W.W.I. pursuit ship will begin in

May MODEL AIRPLANE NEWS

This series will include detailed drawings of the Mercedes engine, used in the Pfalz and also in many other German service planes.

Scrap Box

(Continued from page 8)

other ingredients. Is that better, Phil? And how about you other fellows, should we give details of record models?

Here is one that should knock over in-the-rut speed demons. On last November 10, Richard Grandel, age 14, set a mark of 120.85 mph in Class VI Junior, with a *Dooling 61* in a *Duraplane* kit model, the aggregate weighing 44 oz. How's them for apples! And here is another. Last Dec. 1, Manuel D. Andrade, Oakland, Calif., heaved a 5/8 oz. Class B Open indoor glider to a mark of 1:08. It had a 14-5/8 in. polyhedral wing, with 45.3 sq. in. of area.

This talk of AMA official records reminds us that last month we invited the AMA to reply to those Indiana beefs about a more democratic way of making the rules. You will recall that the Indiana Gas Model Ass'n thought enough leaders, clubs, etc., would be interested to help pay the expenses of an individual poll. If this sounds like a swell suggestion it is also an old one, for all of us, officials included, always wished it was possible. Russ Nichols, executive director of AMA, offers something to chew on but also first points out a few difficulties, such as hard to evaluate factors that spring into being with a large ballot mailing. For example, there is the addressing and mailing of some 30,000 pieces of mail, and the help needed to tabulate all these returns, to say nothing of printing and preparing the mailing.

"In thinking this over," says Russ, "it seems to me that perhaps we should go at the problem from the other end, namely that of devising a different procedure for the process of changing rules and then proposing the necessary amendments to the by-laws to accomplish this. For example, if the clubs in the various districts were willing to raise funds for this purpose, it would seem to me that the logical next step would be to pay the way of their contest board members to an actual meeting of the body to be held in some centrally located city. Of course," Russ goes on, "this should be done with plenty of advance notice so that each member could come to the meeting with a thorough understanding of what the model builders in his district want."

Russ makes the point that there is no other organization of comparable size that does not carry on its voting and policy procedure by actually holding a national meeting or convention. Since it is obvious that we can't pay our way as individuals to such a convention or meeting it might not be too great a strain on various clubs to get together and raise railroad fares for their two contest board members once a year. But where do we go from here? You Hoosiers started this. How about picking up the ball and running for another down. Maybe we'll be able to push the ball over the line, if we all put our heads together. (We hope to publish replies, if any, two or three issues from now—this being written in mid-January.)

We apparently underestimated the lightness of ships with glo-plug engines, for Dick Korda tells us about a new 4-1/2 oz. 10 in. *Arden .099* speedster. The "butchered" *Arden* is on its side with a cylinder pointing to the left or outside wing. A butterfly tail with elevator on the outside half, and an odd "flat" look distinguish this unusual design. Dick is going to have a hard time keeping design secrets in the future from at least one other Cleveland expert. George Reich has it figured out. He got himself engaged to Dick's sister.

Model trends around Little Rock are largely what oldtimer John Sadler likes to build. If John goes free flight, so do the boys. Currently it is U-control, so you can guess what happened to free flight. The Little Rock boys are going faster and faster and Arkansas is becoming one of the hot spots. Sadler cross-countryed all the way to Charlotte, N.C., last fall and came home buoyed over a second place won at 111 mph with a biplane with a fixed gear. Also present was a father and son team with three PDQ kits and six engines—one for each class. The kid chewed bubble gum



Crescent

OF CALIFORNIA

out of the West, comes the best

CUSTOMER

satisfaction is the main idea of Crescent service. Don't come to Crescent for free (?) goods, but if you like prompt service with guaranteed satisfaction, you'll like doing business with us. Dependable California merchandise a specialty! We also recommend the following items:

*Means California Merchandise

Engines

- *Dooling 61 \$35.00
- *McCoy 49 25.00
- *McCoy 29 19.50
- *Ohlsson 60 11.95
- *Ohlsson 23 9.95
- *Ohlsson 19 9.95
- *Anderson Splitfire 60 24.95
- *Fox 59 29.95
- *Atwood Champion 17.50
- *Madewell 49 12.50
- *Contestor 18.50
- *Cyclone 60 22.00
- *K & B Torpedo 29 18.50
- *K & B Torpedo 24 16.50
- *Dennymite 6.95
- Arden 099 PB 12.50
- Arden 099 BB 15.50
- *Sportsman Jr. Hot Pt. 14.95
- *Sportsman Sr. Hot Pt. 16.95
- *Mighty Midget G.P. 14.95
- *Vivell Diesel 11.95

Control Line Kits

- *Madman (C) 10.00
- *Box Car Chief (C) 5.95
- *Box Car (C) 5.95
- *Casalatre (C) 14.75
- Super-Zilch (C) 4.95
- *Snafu Ercoupe (B-C) 9.95
- *Snafu Typhoon (B-C) 10.95
- *Snafu PT-19 (B-C) 8.50
- *Snafu Zero (B-C) 9.95
- *Skychief (B-C) 6.95
- *Skeeter (B-C) 3.95
- Orbit (B-C) 6.95
- A. J. Fireball (B-C) 7.95
- Capitol "400" (B-C) 4.95
- Skybox Trainer (B-C) 3.95
- Skybox Stunt (B-C) 3.95
- Ryan Fireball (A-B-C) 3.95
- Whippet (A-B-C) 3.95
- Greyhound (A-B-C) 3.95
- *Snafu Magician (B) 3.95
- *Box Car Dinky (B) 4.25
- *British SE-5 (B) 4.95
- Cyclone (B) 4.95
- Zing (B) 4.95
- Trainee (B) 3.95
- *Fairchild PT-19 (A-B) 5.45
- Hawker Super Fury (A) 2.50
- *Fokker "Tripe" (A) 3.50
- Whirlwind Jr. (A) 2.95
- Hall Racer (A) 2.95
- Gee Bee (A) 2.95
- Skystreak (A) 1.95

Free Flight

- Mercury (C) 5.50
- Powerhouse (C) 5.95
- Playboy Sr. (C) 6.00
- Buccaneer Spl. (C) 6.95
- Pacer (C) 4.95
- Mercury Jr. (B) 3.95
- Powerhouse (B) 4.95
- Playboy Jr. (B) 3.25
- Buccaneer Spl. (B) 3.95
- Silvire (B) 3.00
- Wanderer (B) 3.50
- Aeronca Champ (B) 4.95
- Honey "B" (B) 4.95
- Zipper (B-C) 4.95
- *Miss Tiny (A-B) 3.65
- *Spook "48" (A-B) 1.95
- Pixie (A) 1.95
- American Ace "36" (A) 1.50
- CO2 Powerhouse 1.50

Accessories

- Wright Test Block 9.50
- U-Reely Control 7.50
- U-Reely Remote 12.50
- *Flightline Reel-Metal 1.25
- *Wood Reel 6" Dia.50
- *Wood Reel 8" Dia.75
- *Flightline Hndl.—Metal 1.25
- *Wood Handle75
- *2-50' Stranded Wire 2.60
- *2-70' Stranded Wire 3.25
- *2-30' Lead Outs40
- Spark Plugs (All sizes)50
- Arden Glow Plug85
- *McCoy Hot Point Plug85
- *Firecracker Coil 2.75
- Aero Quality Coil 3.00
- Aero Ft. Wt. 2.50
- *Competitor Coil 1.95
- Aero Racer Condenser60
- Aero Condenser35
- Metal Condenser30
- Slide Switch25
- Toggle Switch50
- *Hillcrest Timer 1.25
- *Austin Timer 1.50
- Arden Timer 1.85
- Arden Booster Jack 1.25
- *Univ. Needle Valve 1.00
- *Battery Box40
- *Voco Bell Crank25
- *Maeco Stunt Tank 1.25
- *Baker Wedge Tank 1.25 (Lg. Med. Small)
- *Ohlsson "60" Tank 1.75
- *Ohlsson "23" Tank 1.50
- *4-Way Plug Wrench50
- *Austin Glue Gun75

Tools

- Dremel Moto Tool 23.50
- Dremel Moto Saw 5.85
- DeLuxe Vibro Tool 16.50
- Hobby Chest #86 10.00
- Hobby Chest #87 15.00
- Xacto Hand Drill 2.75
- Xacto "C" Clamps (4) 1.50
- *Ungar Soldering Kit 2.00
- *Ungar Woodburning Kit 2.00

Gas-Powered Boat Kits

- O-Gee (B-C) 5.95
- O-Gee Hardware Kit 1.95
- Harco Cruiser 4.50
- Chris Craft 4.50
- Owens Flagship 4.50
- "Sea Myth" Luxury Cabin Cruiser 13.95

Racers

- *Thimble Drome "Champ" 3.95
- *Thimble Drome Wind-Up 2.95
- *Thimble Drome w/tether 2.25

Misc. Kits

- 32 Pd. Carrennade 4.50
- Sea Mortar 4.00
- One Pounder 4.00
- Field Artillery 5.00
- *S.F. Cable Car 2.95
- *Horseless Carriage 1.50
- *Covered Wagon 3.95
- *Stage Coach 3.95
- *Sportsman Conv. 1.00
- *AVR Hot Rod 1.00
- *Midget Racer 1.50
- *Metal Quonset Hut 1.95

NEW O & R FUELS

Sensational "hot" fuels just announced by Ohlsson & Rice. Increased R.P.M.! Improved lubrication!

FOR STANDARD IGNITION
Ohlsson & Rice No. 1

Pint 75c
Quart \$1.40



FOR GLOW PLUG
Ohlsson & Rice No. 2

Pint 75c
Quart \$1.40

NEW O & R GLOW PLUG

An improved tested glow-plug for dependable performance.

Each 85c
O & R 23 Special \$11.95
23 9.95
19 9.95
Rotary Valve 60 Special 6.00
Rotary Valve 19 & 23 5.00
Tank Mount 1.75

AUSTIN-CRAFT GLUE GUN



Puts cement on edges and in tight corners. Very handy. 75c

AUSTIN-CRAFT PLUG WRENCH



4 Sockets to fit all plugs. Protects head fins and plug porcelain. 50c

POSTAGE FREE IN U. S. A.
Our policy: Minimum order \$1.00. Send remittance in full. \$1.00 with C.O.D. orders. (Calif. residents please add 2 1/2% sales tax.)

CRESCENT MODEL SHOP: PLANES, BOATS, TRAINS

5620 West Pico Blvd. Los Angeles 35, Calif.

DELONG "30" MOTOR

takes
a

NOSEDIVE
in price
now **\$15.50**
was **\$19.50**

**NOW AVAILABLE
DIRECT
to DEALERS**

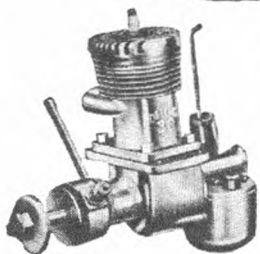

The Company has been completely reorganized and is now able to give immediate shipment of motors and parts directly to dealers. Write today for prices on motors, parts and accessories. Now in stock:

- Complete Motors
- Neoprene Tubing
- Spare Parts and
- Super Motor Control Handle

Super Motors, Inc.

2093 E. 19th • Cleveland 15, Ohio

and the old man switched engines all day. They took every junior event. Personally, we think the father-son deal in U-control is a fine thing for the hobby. Before control line came along such teams were a phenomenon.

Texarkans (or is it Texarkanians?) figure they have a pretty hot stunt man in a chap named Corley who believes in taking things easy. He lies flat on his back and does eighths in series. Corley favors a big fast ship capable of 92 mph on the "straight-away." Span is 54 in., power *Hornet*, prop 11-8.

Stunting is fun, no doubt, but it is also funny. So many fellows take to it like ducks to water. And some of us really have our headaches. Paralysis of the brain, or dolor de la cabeza as they say in high school Spanish (did we get that right?), or sorrow of the head. Once the ship is on its back, thinking processes freeze. No wonder you see crates with wheels on both top and bottom! Previous modeling experience doesn't seem to help, and experience with real aircraft seems to be a handicap. Jack Reeves, an ex-Army pilot from Texarkana and a good control line man, has his troubles with inverted flying. "I flew it inverted twice—the first time about half a lap and the second time over two laps," explains Reeves. "Both flights ended in inverted rather shallow dives into the ground. In other words, I gave it a slight amount of up to get back to level flight which, of course, increased the dive—then I lost all power of normal thought process and just did nothing 'til bang! I can talk myself through a whole flight inverted—on the sidelines, but boy, when I get that handle it's different. I just can't push when it seems I ought to be pulling." Like we said, this sort of thing happens to a lot of us. Do any of you not rock stunters have a few helpful tips, or do you have to be born that way?

Speaking of stunting, we hear our figures on Jim Walker's *Glo-Plug Fireball* were almost double what the ship really weighs. Now we hear that it is 10½ oz. People who have seen it flown say it is like a whirling dervish, responds fast and has a skidless, mushless grip on the air like roller skates in a sand pit. You can make a mistake, pull out of it, make another, get out of that... what suspense!

"The Texans are *Glo-Plug* happy in Dallas," says Jim Tucker, another ex-fly boy of Monticello, Ark. "I imagine you have heard of Sam Beasley, their local hot shot; I was reliably informed that he hit 148 mph with a *McCoy 49*, *glo-plugged* and pressure cowed. They have done 138 mph with a *Hornet*. They are all using the new semi-toothpick (9-13) *Rev-Up* prop which is made in Dallas." Though we haven't seen one of these props yet, we hear they are beautifully machine cut. Tucker, incidentally, swears by benzol for fuel. He gets it from a drug company at \$1.75 a gallon and warns about being sold white gas as benzol. "This stuff is hot," says Tucker. "when mixed right, with the right ingredients, and used while still fresh. The *Dooling* will burst your ear drums if you stand on the exhaust side while running that mixture in it."

We don't know where the idea came from, but for the benefit of an occasional U-controller who asks us not to go rough on said sport, we wish to go on record by saying that we don't dislike what some of the rabid free fighters call yo-yo. We probably will never fly speed, but we feel that the speed model comes closer than free flight to the engineering type of design problems of real aircraft. The good speed builder gets into problems of cooling, venting, efficiency, loadings, that free fighters hardly care about. The hot speed job is more than an engine, we'll be the first to admit. And stunting really interests us. So does scale. As a matter of fact, the only way we could get interested in speed would be in a flying scale event. Through the years there has appeared a wondrous line-up of speed jobs, the Chester and Howard racers, the Caudrons, etc. Picking the right job for your motor and getting the motor into it without parting too much from scale would be a real test of skill. Such an event would

The Monocoupe

BY
STERLING



\$4.95
BY MAIL
Add 30c

CUSTOM SPUN ALUMINUM COWL

- Carved Leading and Trailing Edges
- Clean Die Cut Ribs, Bulkheads, Tail Surfaces, Etc
- Hardware Kit • Full Decal Sheet • Formed Wire Landing Gear • Step by Step Instructions.

Steals the Show — Wherever You Go

A natural for that beauty event. Ideal for sport and stunt-flying. Construction time: 4 evenings.

A 36" SCALE CONTROL LINE MODEL

For any B or C Engine
Sterling Engine Test Block...\$7.50 BY MAIL
Add 15c
NOW AT YOUR DEALER

DISTRIBUTORS! DEALERS! CONTACT US
AT ONCE FOR FULL INFORMATION.
Write or Wire Today to
Sterling Models, 4612 C St., Phila. 20, Pa.



NEVER BEFORE

WHIPPET

SUCH CONTROL LINE KIT VALUE

- Price 1/2 of similar kits
- Takes any A, B, or C motor
- Fully carved and hollowed all balsa fuselage • Aluminum Tubing
- Solid balsa wing cut to shape
- Solid balsa tail assembly cut to shape
- Cut to shape plywood motor mount
- Ready bent landing gear
- 2 Rubber wheels
- Pilot Control (New Improved Controline)
- Full size plans Fuselage 19" \$3.95
ADD 50c BY MAIL
- Wingspan 21½" Chord 4"

MASTER Modelcraft

1074 FRANKLIN AVENUE, NEW YORK 56, N.Y.

THE NEW LOOK!

The 1948 rules for free flight gas models will bring about a new look in design. Hints on how to design your ship to get the best performance under the present regulations will be found in May MODEL AIRPLANE NEWS. On Sale Everywhere April 9th.

SPEEDWAGON

134.6 MPH—L. WAGNER
NIAGARA FALLS, N.Y.

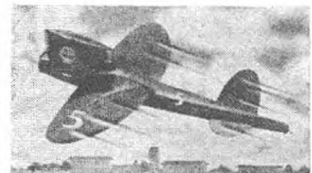

Years ahead in design, sensational in value, it's another winner. With built in "Circle Flight" and "Weather Vane" stability YOU too can have those record breaking flights. With either a Class "C" or "D" Power Plant YOU too can have speeds well over 130 MPH!

ASK TO SEE IT TODAY!!

POWER: Any Class V or VI Engine.
WING AREA: Either 77 or 87 sq. inches.
WING SPAN: Either 18 or 20 inches.
FUSELAGE: 20" over all.
WEIGHT: Only 28 to 32 oz.
HIGH SPEED: Over 130 MPH.

AT YOUR DEALER ONLY \$4.95

**DE BOLT MODEL
ENGINEERING CO.**
WILLIAMSVILLE 21, N.Y.



introduce a new element, besides flying skill, the hot engine, fuels, props, etc. They'll be important, but the advantages or disadvantages of the real ships selected would be a major factor. Factory plans, or at least bona fide three views like magazine plans, should be required. Points should be awarded on some simplified basis for appearance, scale, etc.; something like the flying scale event only simpler and more practical. What would happen if these ships had to be built to uniform scale? Two models in one circle would be a thrill. Hold your hats!

So the secret police won't pick us up as a free flight deserter we want to pass on a thought on those new designs. One factor we intend emphasizing in our own stuff, if we ever get chance to open that glue can, is the relationship between lifting area and the thermal. Anybody knows that a C job is more apt to make like a sailplane than an A job (that's force of habit; we don't get it through our noggin that there are also Class D and E these days!); so with no wing loading to contend with why not use all the area that you can get away with, efficiently, of course. Use a really thin airfoil, even if it means a lower L/D. You'll stay within the limits of the motor to drag the ship upstairs in a hurry. It'll float, too. Clean up the design and cowl in the engine to eliminate that flat-plate firewall drag.

Charles H. Muth, secretary for Minneapolis Model Aero Club, with the sad case in mind of untrained volunteer timers who work with much enthusiasm but little skill, suggests a national pool of timers who have proved themselves competent in reasonably large meets, and who would be willing to assist in meets in nearby areas—both as timers and instructors for new timers. Well, it seems to us that in small areas and the average contest the meet management, or at least their adviser, if he has anything between the ears, would know of available timers. But in larger meets there never seems to be adequate timers. One possibility would be to have the contest director supply the list of names and addresses of timers used to the Academy, or at least to the district vice president who then could supply information when somebody runs short of people who make with the watches. Hobby shops could keep a file of timers in their areas, if sold the idea. Another aspect of this problem is that the less flights allowed for all types of models the further the timers will stretch at any given meet. We wondered about this while watching control line speed flights tie up three timers simultaneously for as long as 15 minutes.

Of interest to clubs who would interest beginners, Muth relates that the Minneapolis Aero Club challenged the St. Paul Modelers to a contest with 12" models—tissue covered—which were flown at the Minneapolis Club meeting place. Ceiling is about 10 ft., with chandeliers furnishing erratic thermals and obstructions. High time, nevertheless, was 3:5.5, and both clubs were so enthused that a return bout was scheduled in Feb. The meeting place? The mayor's reception room at the Minneapolis court house!

A letter from Eddie Cosh, received just as this material was ready for the printer, confirms some vague rumors we have heard that 1948 will see a resumption of Wakefield competition. Though final plans have not been made, it seems there will be an F.A.I. meeting held at Cleveland during the air races and it is proposed to hold the Wakefields at this time. Eddie is unable to say whether a team will come over from England or whether they will have to send their models over to be flown by proxy. At any rate, the English flyers are planning to run a series of elimination trials all over the country before the finals are held, and we are assured that the very best possible team will be chosen.

Rules will be the same as they were prewar; we urge interested modelers to study them carefully and start their building program for the Wakefields at once.

National Boys' Club Week
April 5th to 11th



SPARKY Says:

PRIZE PACKAGE #1

BY POPULAR DEMAND

THE FIRST OF A SENSATIONAL SERIES OF "SPECIAL OFFERS" TO USERS OF "THE SPARKY COIL!" ONLY BY SELLING DIRECT TO YOU ARE WE ABLE TO OFFER THESE PRIZES!

LOOK! LOOK! LOOK!

A \$2.75 VALUE for Only \$1.25 COMPLETE!

OUR REGULAR SPARKY COIL



OUR PRIZE OFFER #1 The "RAZOR KNIFE" KEY CHAIN



COMPLETE WITH LEAD!

Yes, our Regular \$2.50 Sparky coil is part of this sensational offer! The same coil that thousands of model builders are finding "The best they have ever used." — regardless of price! Send for "The Sparky Coil" and take advantage of this special offer! It's a value at \$2.50! It's a sensation at this new low price!

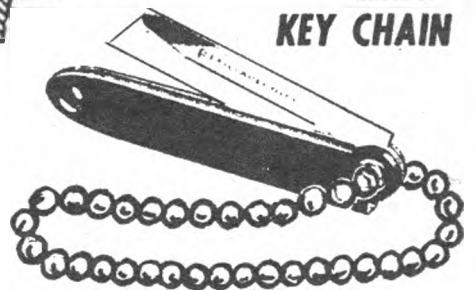

Every model builder needs it! Every model builder wants it! Here is a honey of a knife that you can carry with you wherever you go—for repairs on the field—building at home—a 1000 uses! It's as sharp as a razor because it is a real razor blade! Always with you because it comes complete with a strong chain! The blade is replaceable! The knife is collapsible! Get your Razor Knife now!

**BOTH FOR \$1.25 INCLUDING POSTAGE!
SEND FOR YOUR PRIZE PACKAGE TODAY!**

SPARKY SPECIALTIES, INC., 173 West Madison St., Chicago 2, Ill. MA2

Dear Sparky:

Please send me _____ Prize Packages. I'm attaching \$1.25 for each package! Send Today — to:

Name _____

Address _____ Zone _____ State _____

FREE POSTAGE . . . FREE INSURANCE . . . 8 HOUR SERVICE

FREE Where FREE can you top this?

THE FOLLOWING ITEMS FREE WITH EACH MOTOR

- | | |
|---------------------------|-------------------------|
| 1. Quality Coil | 6. Alligator Clips |
| 2. Metal Condenser | 7. One Foot Fuel Line |
| 3. High Tension Lead | 8. 6' Ign. Hook-up Wire |
| 4. 100' Control Line Wire | 9. Two Pen Cells |
| 5. Slide Switch | 10. Mounting Bolts |

GAS ENGINES

McCoy 29	\$19.50	Sportsman, Jr.	14.95
McCoy 49	25.00	Sportsman, Sr.	16.95
McCoy 60	35.00	K and B Torpedo 29	\$18.50
O. K. 29	16.50	Hornet	35.00
O. K. Super 60	18.00	Super Cyclone GR	22.00
O. K. Twin	55.00	Super Champion JH	23.50
Arden .199 B. B.	18.50	Pacemaker	24.95
Drone Diesel	21.50	*O. K. Co.	4.95

* NO FREE ITEMS

ALSO COMPLETE LINE OF KITS AND ACCESSORIES

Simple mailing instructions: Print name and address clearly, list items, enclose check or money order. Free packing, handling and postage. No minimum order. No C.O.D.

THE EASTERN SUPPLY CO.

Box 615 New Britain, Conn.
Operated by Active Model Builders

Flash News

(Continued from page 2)

SECOND NORTHROP YB-49 eight-jet Flying Wing bomber flew away from its Hawthorne, Calif. birthplace to Muroc Base for extended tests. Reports from the first YB-49 reveal high speed of better than 500 mph and a phenomenal rate-of-climb.

BEECH AIRCRAFT has designed an ambulance version of the "butterfly tail" Bonanza for charter service. The modification consists of removing the right front seat and the entire rear seat and installing a small left rear seat and a metal-framed stretcher easily clamped in place. This provides room for pilot, attendant and patient.

SUCCESSFUL TEST flights have been made on the Aquaflight, Inc., amphibian, Aqua I. A six-place design, the craft is powered by two Lycoming 125 hp engines. It is a high wing monoplane with sponsons projecting from either side of the fuselage at the waterline. Of composite construction, the amphibian has a wooden hull and metal wing structure. Cruising speed is 125 mph over 750 mile range, 1400 lbs. useful load.

THE HUSKY is looking for a new owner and several offers have been received for the purchase of this Canadian-built single-engine "bush freighter." Fairchild Aircraft Ltd., one of the oldest aviation companies in Canada, announced its dissolution and the placing for sale of all rights, technical data, tooling and parts including one complete airplane, of the Fairchild Husky.

THE NOISELESS AIRPLANE, developed by NACA last year, is going to be even more "noiseless". Latest development in the project is the transfer of the airplane (a special Air Force Stinson L-5 Sentinel) to the Aeronautical Research Foundation, a group of researchers from Mass. Institute of Technology. Multiple propeller blades (up to 8) are now being tried, together with various types of Maxim silencers to reduce noise to the lowest practical limit. After this is achieved, the noise will be progressively increased until the threshold of "nuisance" is approached. The design will then be offered to manufacturers free for incorporation into production designs.

BIGGEST YEAR in history of the light-plane has been rung up with final 1947 reports showing total production of 16,023 personal aircraft valued at \$53,206,000. This is about 150% better than 1941, best prewar year. Oddly enough, the record shows that three and four-place types outnumbered the popular two-place lightplanes with 7940 of the latter being delivered against 8083 of the 3-4 place type. This year the value of production is predicted at about the same (about \$50 million), but the numbers are expected to drop 50%, the difference being in the increasing sales of 3-4 place types.

SOMETHING THAT must be very interesting to watch is Northrop's new supersonic sled! The device is mounted on steel rails 2000 ft. long and powered by 5 giant Monsanto solid fuel rocket motors developing 10,000 lbs. of thrust each, the equivalent of 150,000 hp! Purpose of the high-speed device is to mount model airfoils for testing at supersonic speed, the sled attain-

Attention! METROPOLITAN N. Y. CITY DEALERS!

YOU are invited and urged to attend the meetings of the reorganized "Metropolitan Hobby Guild" which has begun to ACCOMPLISH BENEFITS FOR YOU!

We are getting flying locations for model builders in this area, and are working on obtaining race car tracks and boat builders locations.

Our meetings have interesting and worthwhile features including: movies, guest speaker, display of new items by manufacturers, etc.

The bigger we become, the more we can accomplish—FOR YOU!

See your jobber for more details— or contact Tex Foster, 105-14 Jamaica Ave., Richmond Hill 18, N.Y.C.

WESTERN DEALERS

FAST * WHOLESALE * SERVICE

Leading Lines of Modelmakers' Supplies, Including

ATWOOD, AIR-O, AERO-SPARK, AIR AGE BOOKS, AIR-AUTO-MARINE, AIR-FLO, ALL-STAR, ARISTOCRAFT, AMECO, AMERICAN JR., AUSTIN-CRAFT, BEACON, BANTAM, AEROGLOSS, CONSOLIDATED, CANNON, CHUPP, C & R, DELONG, DAVIES, DOOLING, CONTESTOR, CADET, CAPITOL, CHAMPION PLUGS, EAGLE, EDCO, E-V, FALCON, FLO-TORQUE, FROM, GIRARD, HORNET, HERKIMER, HECO, HURRICANE, JASCO, McCOY, MELCRAFT, MEGOW, MONARCH, POWER-PLUS, RAY, MINIJET, SCIENTIFIC, SNAFU, SULLIVAN, TESTOR, TOPPING, TORPEDO, VIVELL, X-ACTO AND MANY OTHERS

Send for Large Wholesale Lists

"HOBBYCRAFTS"

DISTRIBUTORS

1327 J ST.

SACRAMENTO 14, CALIF.

"Rite-Pitch" THE N-E-W-E-S-T NEW 1948 MODEL

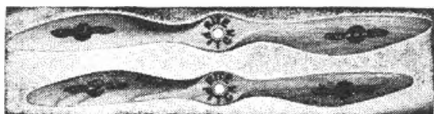

WORLD'S FINEST GAS MODEL PROPELLERS!

CONSTANTLY IMPROVING TO MEET ALL CONDITIONS!

THIN, FAST AIRFOIL SECTION!

Thinner hubs so that even 12" pitch propellers will fit standard motors without carving down.

SUPER STREAMLINING from hub into blade section to reduce Propeller drag to an absolute minimum. Finer, "Silky-Smooth," High gloss lacquer finish!

MORE MODELS ARE FLOWN WITH "RITE-PITCH" THAN WITH ALL OTHER MAKES COMBINED!!

8"-9"-10"-11"50c LIST
12"-13"-14"60c LIST
ALL DIAMETERS ARE MADE IN 6"-8"-10"-12" PITCH FOR STUNT—SPEED—CONTROL OR FREE FLIGHT.

BUY "RITE-PITCH" ACCESSORIES For Better Flying At Lower Cost!

JOBBER: Contact us today!

Bob Roberts



110 W. 7th Ave., Gary, Ind.

GET THE FREE "RITE-PITCH"

"Compendium of Information on Gas Model Propellers." At Your Dealers or Write Us.

DEALERS: All Jobbers who have your interests at heart and want you to make money can fill your order.

Checking Horsepower

(Continued from page 12)

ing top speed obtained) you can see how your engine's output hp varies with engine speed. All runs must be made at top engine speed with each prop used. The results of these runs can be plotted in a smooth curve such as Fig. 1. If a few points seem scattered, recheck those runs since the correct curve will be smooth.

Just a note on ignition point flutter; if your points begin to flutter the hp will fall off rapidly, so set them closer together before continuing. When you have made a series of runs on your engine and found its power peak, try different fuels to see which give the most power.

When you mount another engine on the stand, check the calibration again because the difference in engine weight may require some change in the amount of lead shot needed for correct readings. If any questions arise during construction or operation of this test instrument, write us care of this magazine and we'll be glad to answer them.

Meet the Rudevator

(Continued from page 29)

the arm (#3) on the rotary tab shaft (#2) and stops the tab in that position. When the armature relaxes, the tab shaft resumes rotation. Almost no power is required of the rubber motor since it only drives the escapement shaft. The rubber motor never drives the rotary tab or vice-versa. The rubber is good to the last twist, and since it will hold so many turns we find that winding once a day is sufficient. Actually the control could be designed without a rubber motor; the rotary tab could be used to operate the escapement, but a time lag would be involved and the overall response to signals would not be as fast.

There are four neutral positions on this type of escapement. This is more than we need; so we use one of them for stopping the airplane motor. The small switch (#8, 9) is normally closed and we wire it in series with the plus side of the ignition batteries. In one neutral position when the electro-magnet is relaxed a small drop of glue (#11) on the escapement shaft hits and opens this switch. We make this occur on the neutral position after down. One must remember not to dwell on this neutral position but to use any one of the other three unless he is ready to stop the engine. For this reason it is best to leave this switch disconnected and rely on an engine timer for the first few flights. The escapement opens this switch every time around, but it goes by so fast that the engine merely burps.

Now for the control head. This is nothing but a simple four point selector switch. We use a typical 12 point rotary selector switch with 4 of the detents flattened out. This leaves 8 detents, 4 of which are sloppy loose and 4 are normal tight and alternated with the sloppy loose ones. We use the loose ones for neutral so there is an extra feel for neutral without having to look at the position of the crank. The 4 tight detent positions are connected into the transmitter B battery. With the control in the left hand and the crank side of the box facing the operator, up is up, down is down, left is left and (you guessed it) right is right. Neutral is when the crank points to any corner of the box.

Synchronization with the rudevator is simple. With the transmitter and receiver on, your assistant starts the engine. The slipstream starts the rudevator rotating. Put the crank in any signal on position.

528 PAGES

"Model Airplane Design" by C. H. Grant

THE COMPLETE INSTRUCTOR ON MODEL FLYING!

4th Printing

205 DIAGRAMS & PLANS

Only \$3.75 at your favorite model or book store . . . or order from publisher, Air Age Inc., 551-5th Ave., New York 17.

FUELS

"POWER MIST"
"SPITFIRE"
"BLUE BLAZER"

FUEL FACTORS YOU RESPECT

1. Comparable to a doctor's prescription
2. Purity tested ingredients
3. Climate tailored compounding
4. Varied selection for different compression
5. 17 years' research knowledge and experience.

FUEL FACTS AND FORMULAS: How to determine the correct fuel. Full information and literature—at your dealer, or send stamped addressed envelope.

FRANCISCO LABORATORIES

3787 Griffith View Drive • Los Angeles 26, California

The rudder will stop in some position, say up. Turn the control box in your hand so the crank is pointing up. You are in sync. If you make a mistake and get out of sync in flight, do the same thing. Our rudder escapement goes up, right, down, left or clockwise as viewed from the rear. So remember to turn the crank clockwise to stay in sync. We prefer it this way, but if you must operate like a pilot, turn the control box flat with the crank on top. Then forward is down and back is up and rudder remains the same. But you must crank counter-clockwise to stay in sync.

There is one case where you can move the crank back and forth in both directions and still remain in sync. This is when you are using rapid alternate left and right rudder alone to jockey the ship in for a spot landing, or when using elevator alone to do loops. Actually, the escapement goes through down while the crank goes through up, but who cares if you are only interested in the one control at the time. The crank can be turned as fast or slow as desired. As a check, we twirl the crank and listen to the rudder escapement rattle in response.

Our ship was designed and built by Dick Schumacher of Burbank at a time when we expected to have to carry about 3 lbs. of radio apparatus. The present rudder installation weighs 1 lb. complete and gross weight is 5 lbs. 10 oz. The 7 ft. wing gives it a glide almost like a sailplane. We fly it trimmed straightaway, of course, and plenty of downthrust is used to hold the nose down under power. Turns of 360° can be made under power before the nose drops dangerously. Power off turns are gentle and can be held to the landing. Elevator down will not cause an outside loop but merely an increase in speed until the large stabilizer balances out. At this point up elevator produces a loop. Simple maneuvers like this are enough to keep one busy at first. The simple formula for our next job will be less airplane and more rudder.

RUDEVATOR PARTS LIST

- No.
1. Rear steady bearing—.032" Alum.—Washers soldered to shaft prevent fore & aft motion.
 2. Rotary tab shaft—1/16" brass rod.
 3. Rotary tab shaft crank—.020" brass sheet.
 4. Rotary tab shaft stop—.032" music wire—one spoke of four-spoke escapement wheel is bent to form this stop.
 5. Escapement wheel—.032" music wire—has three plain straight spokes and one stop spoke (4). All spokes are soldered into drilled holes in a #0-80 brass nut—then unit is soldered to shaft.
 6. Escapement shaft—1/16" brass rod.
 7. Ignition switch platform—part of (27).
 8. Ignition switch movable contact—insulated—.006" brass sheet—contacts, coin silver.
 9. Ignition switch stationary contact—.006" brass.
 10. Armature—1/16" iron. (Hole for shaft oversized to prevent binding—#0-80 nuts soldered to shaft.)
 11. Ignition switch cam—model airplane cement built up to required height on escapement shaft. Switch shown open (it is normally closed).
 12. Escapement shaft crank—.020" music wire.
 13. Rubber motor crank bearing—1/16" brass tube.
 14. Rubber motor hook—.020" music wire.
 15. Rubber motor—2 strands 1/32" or 1/16" square—any practical length.
 16. Forward Bearing Bracket—.020" brass sheet.
 17. Rubber motor crank—.020" music wire.
 18. Armature stop—part of (16).
 19. Armature return spring support—part of (16).

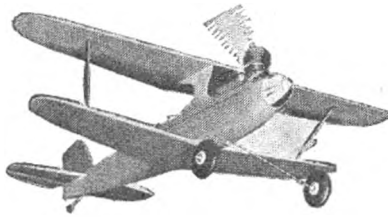

CARL GOLDBERG'S NEW NIFTY

Beautiful Biplane Control Model "PRECISION PREFINISHED" NO-CARVING KIT

- ★ Prefinished, Carved and Hollowed Fuselage
- ★ BOTH Sets of Wings Precision Air-foiled!
- ★ Stabilizer, Elevators, and Rudder Precision Shaped.
- ★ Finest Quality "Job-Selected" Materials: Balsa for Lightness, Hardwood for Stress.

- ★ Formed Landing and Tail Gears. Die-Cut Plywood Cabane Struts.

- ★ All Necessary Formed Wire and Metal Parts.

- ★ Wingspan 23 1/2", Length 20". Designed for .19 to .49 Engines.

- ★ Simple Plans that Really Explain!

PLENTY OF SPEED, STABILITY AND MANEUVERABILITY

Makes "NIFTY" Loops!

EASY TO BUILD—FUN TO FLY!

KIT G-3 COMPLETE
less liquids and
wheels ONLY

\$4.95

TWO OTHER POPULAR American Hobby KITS!

RAINBOW

ZING!

Kit includes airfoiled wings, completely shaped fuselage, stabilizer, elevators and rudder. Formed landing and tail gears, all necessary metal parts, decals and plans that REALLY explain. For engines .23 to .49. 30" Span, 26" Long. **\$3.95**
Kit G-2.....Only

"Precision Prefinished" kit. Hardest work already done. Fuselage shaped and hollowed. Wings air-foiled, sanded and slotted. Metal parts ready to use. No Printed Sheets to cut, No Carving, No pins. 24" Span, 22" Long. **\$4.95**
Kit G-1.....Only

American Hobby SPECIALTIES

2900 S. MICHIGAN AVE.
CHICAGO 16, ILLINOIS

The H & H Model Motor

1. Hot Coil Ignition (Patented)
2. High Speed (over 10,000 RPM)
3. Quick and Easy Starting
4. Light Weight (only 8 ounces)
5. Compression Ratio (approx.) 6 to 1
6. Not a diesel
7. Displacement .45 cu. in.

A New Thrill in Flying

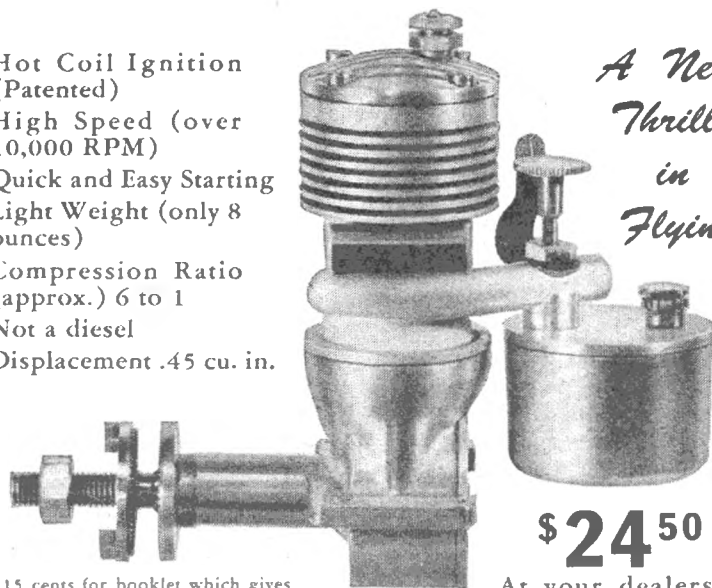

\$24.50

Send 15 cents for booklet which gives complete information, together with plans for a practical simple model plane.

At your dealers—
or order direct

H & H MODEL MOTOR CO.

307 W. MARSHALL STREET • NORRISTOWN, PA.



FRANK CUMMINGS
OF LOS ANGELES
NATIONAL A.M.A. CHAMPION
SELECTS FOX .59 FOR
CONTEST WINNING PERFORMANCE

FOR YOUR FREE-FLIGHT, CONTROL LINE SCALE, STUNT, SPEED, OR RADIO CONTROL JOB, INSIST ON A FOX HI-TORQUE OR HI-SPEED MOTOR. NO OTHER ENGINE POSSESSES SUCH DESIRABLE FEATURES AS THE FOX:

THE HI-SPEED MOTOR WEIGHS ONLY 9/4 OZ., DEVELOPS 1 1/8 H.P. AT 16000 R.P.M., IS EASY TO START EVEN WITH SMALL PROPS, COMPARES IN SIZE TO MOST .49 ENGINES, HAS A LONG EXTENDED SHAFT, IS IDEAL FOR STREAMLINE COWLING, WILL RUN IN ANY POSITION AS TRACTOR OR PUSHER, OPERATES AT PEAK PERFORMANCE WITH EITHER STANDARD IGNITION OR GLOW PLUG, THE ONLY MOTOR WITH A HORSE POWER TO WEIGHT RATIO OF 2 H.P. PER POUND.

BUILD AROUND, FLY AROUND A FOX, AND OUTFLY THE REST.

REMEMBER, "THE WORLD'S MOST VERSATILE MOTOR."

BORE937
STROKE860
DISPLACEMENT599

\$29⁹⁵

AT YOUR FAVORITE HOBBY SHOP



1948 SOUTH GRAND AVENUE
LOS ANGELES 7, CALIFORNIA

20. Armature return spring—1/8" dia.—solder to armature.
21. Armature bearing—.032" music wire soldered to bottom of armature.
22. Coil—2 required—4 to 6 ohms total when connected in series; these were from a code practice buzzer.
23. Magnet back plate—1/16" iron.
24. Escapement wheel 2d stop—.032" music wire. This is a labyrinth stop—rotation of escapement wheel is clockwise as viewed from rear—(up, right, down, left)—as each spoke leaves first stop (25), it is caught by 2d stop.
25. Escapement wheel first stop—.032" music wire. Must clear spokes of wheel. Both stops are soldered to (27).
26. Base plate—1/4" hard balsa.
27. Rear bearing bracket—.020" brass sheet. Both bearing brackets are held by #2-56 machine screws which bolt thru base plate & airplane structure. Assembly is checked for alignment after installation.

Skipper

(Continued from page 17)

scape, be sure that the entire ship is doped sufficiently to be really oil-proof. That means at least four coats of dope. We trust that somewhere along the line a friend has come to visit you and that you've been able to inveigle him into covering the wing. If not, call up somebody good at covering jobs (and tell him to bring the Silkspan). Or else do it yourself, the hard way.

Ready to fly Skipper? With the model balancing halfway between the leading and trailing edges, glide-testing should be attempted from shoulder height. If the model follows a relatively straight path, try higher launchings from overhead. Point it down at the ground about 30 ft. ahead of you, so that you won't stall it purposely. Since a small amount of incidence is built into the wing you should have no troubles so far. If the model dives or stalls, make adjustments on the wing incidence. To correct the diving tendency, add sheet balsa under the leading edge. For a stall cure, add sheet balsa under the trailing edge. The rudder tab should be offset to get a slight circle to the right.

Now for some power flights. For some undetermined reason the author's engine runs for only 30 sec. on a full tank, adjusted for a rich feed. By holding the model and monkeying with the fuel adjustment for 10 sec., an engine run of 20 sec. is had. (I don't ask questions—I just have fun). In any event, don't risk losing the model by using too long an engine run. If necessary, use a timer to cut off fuel or to close the air intake completely.

Well, to get back to flight-testing. Make power flight adjustments with thrust offset. Once your wing and tail surfaces have been adjusted in glide-testing, leave them be! For flights with the model circling to the right under power and in the glide, about 3° downthrust is needed. Adjust for a tighter circle with the rudder tab, if you want to, but use a little left thrust to compensate; the model should not be made to circle tightly under power, as the net result is a waste of power. A tight circle in the glide won't hurt, since the model will remain in small thermals.

For those interested in contest work, the weight of Skipper should be at least 10 oz. to conform with the 100 oz. per cubic inch rule. If it is necessary to add weight to bring the model up to specs, put the weight in the approximate center of the pod, as too high or low a center of gravity will make the model harder to adjust for power flight.

Don't be lackadaisical about putting your name and address on the model—these things do get lost you know.

Now!
try

EXOL Model Aircraft Power Fuel

DESIGNED FOR RACING ENGINES

A scientific blend of highest purity ingredients, as recommended by leading model engine manufacturers. Contains no gasoline or petroleum fraction of any type. Lubricated by highest quality castor oil.

EXPERIMENT INCORPORATED
Products Division
RICHMOND 2, VIRGINIA
Racing Fuels for Two-Cycle Engines

STOP WATCHES

15-Jewel Elgins Precision Movements
Sweep-Second 1-10 Second
Hands Timing

Ten Seconds Per Revolution
of Sweep Hand

Sent Postpaid for Only **\$9.95** Cost Gov't. \$39.50

ORDER TODAY this precision movement ELGIN STOP WATCH which was used by Army Air Corps Navigators. Ideal for clocking your model's speed. Moneyback guarantee if not satisfied. Sorry, no C.O.D.'s.

BROPAR

DISTRIBUTOR
P. O. Box 275, Dept. 71C
San Antonio 6, Texas

The Only Magazine Devoted Exclusively to the Active Aero-Modeler for 19 Years!

MODEL AIRPLANE NEWS

By Subscription Only \$2.50 per Year

Have Fun! Form MIDGET RACE CAR CLUBS!

It's New!
It's JET POWERED!

Build this 9-inch Midget Race Car

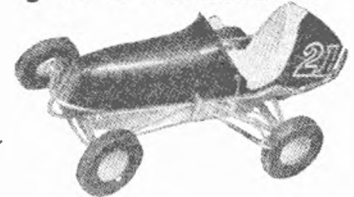

Equipped with rubber tired metal wheels. All parts semi-cut. Easy to assemble. Three view detailed plans, clearly illustrated.

Complete Only \$2.50 per kit

Plus 15c for postage

SPORT-O-SPEED

520 Lotus Road, Dept. D, Ridgewood, N. J.

Design Forum

(Continued from page 24)

the pull of its mass. This creates an opposite force, Ps, due to the air pressure against the outward side of the fuselage, wings, and other parts of the airplane. The center of reaction of this air pressure is directed against the side of the plane at some particular point CLA. Theoretically this point would be the center of the side projected area of the airplane, and was named the "center of lateral area."

As a matter of fact this side pressure in various types may react at other points which, however, are not far from the CLA. In some planes it may be forward; in others it may be to the rear—above it or below it, but practical tests have shown that this CLA point may be used as the theoretical center of side pressure with very accurate results.

In Mr. Brown's airplane this side force acting at CLA when turning at high speed reacts above the CG. The CG pulling outward and the side force pushing inward creates a rolling couple which banks the plane inward. The further the CLA is above CG the greater this couple will be and the more it will bank the airplane against any resisting recovery forces that might develop. Many modelers say that the CLA has no effect, and they proceed to accept this steep banking of planes and apply corrective measures in the form of resisting forces. Briefly, they deny or overlook the disturbing forces and try to correct the trouble by applying recovery forces. By the latter we mean forces which roll the airplane back into normal position after it has been displaced. This produces constant rolling back and forth.

Anyone who has been at contests cannot deny that most of the airplanes flown bank critically. Some use large dihedral to produce restoring force and in so doing often make matters worse. Others reduce size of the fin; this is logical because if the fin is small and there is considerable area forward beneath the wing the nose will not drop as quickly as when the fin is large. Furthermore, there is more time to restore the airplane to its normal flight position laterally before the nose drops into a dive. In this way the fin is a deterrent to spiral instability but not a corrective. It only reduces the degree of spiral instability.

Some have conceived the bright idea of placing the fin low. Fig. 3, not to cure spiral instability but to create a nosed up position when the plane banks sideways under the effect of the high CLA. This does not cure the spiraling tendency but keeps the nose of the plane pointed upward so that it spirals upwards instead of spirals down. Typical examples of this condition are pylon models. Take for instance the *Zipper*, which, it is claimed, is spirally stable. This is refuted by the fact that some flyers boast how well the model spirals upwards. By applying small fins and placing them in a low position, the designer has not eliminated the spiral tendencies but has merely directed them into a constructive maneuver instead of a destructive one.

Perhaps now you can see what is wrong with Mr. Brown's airplane. The CLA is considerably above the CG, Fig. 1. This in itself creates a spiraling tendency. Second, the fin or sideways tail area, is high. This causes the axis DD' which passes through the centers of gravity and lateral area to be slanted downward at the nose. The airplane rolls first about this axis DD' when banking due to external forces, and about axis

Now! Power Transmission Unit for Thimble Drome Racer

Now that the demand for a good power transmission unit has been answered, the popularity of the Thimble Drome Racer will be greater than ever. Your National Dealer has or can get both the car and transmission unit for you. Car is die cast aluminum with aluminum rubber-tired wheels, chrome exhaust stacks, wobble pump, simulated leather seat and back, instrument panel and numbers.

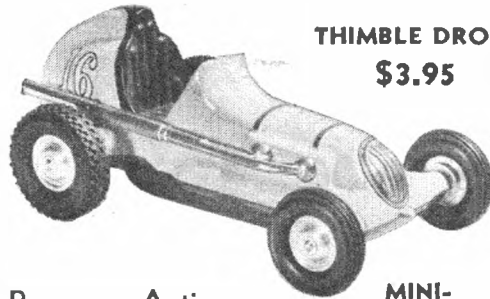

THIMBLE DROME

\$3.95

Power . . Action . .
Speed . . Plus Beauty
and Authentic Scale

MINI-MOUNT
Complete
\$9.45

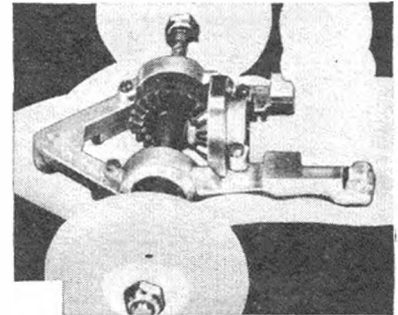

The Mini-Mount Transmission Unit, die-cast frame slips easily into the Thimble Drome chassis as shown in photo. Universal type flange or radial mounts for all Class A and most Class B engines. Drilled and tapped, ready for installation.

Some of the features include: Ball Bearing Axle Hangers— $\frac{1}{4}$ Inch Steel Axle, threaded and fitted with four speed-lock nuts—Adjustable Allen Screw Lock Collar—Fly Wheel—L-147 Beveled, Hardened Steel Ring and Pinion Gears, and $\frac{1}{4}$ — $\frac{3}{8}$ Brass Bushings—Housing for Optional Addition of Ball Bearings for Bantam Engine Installation.

Dealers!

Here is the double-barrelled sensation for 1948. If you have not already ordered, write National today.

Unit, less gears 4.95
Unit, with ring and pinion 9.45
Unit, with ring gear 7.45
Pinion Gear, Arden 2.00
Pinion Gear, $\frac{1}{4}$ inch 2.00
Bantam Main Bearing 1.75

The Mini-Mount Handles all Class A —Most Class B Engines

NATIONAL MODEL DISTRIBUTORS

2516 N. GREENVIEW AVE., CHICAGO

ANDERSON SPITFIRE

"The Engine Experience Built"

NOW READY
FOR
DELIVERY
AT YOUR
DEALERS!

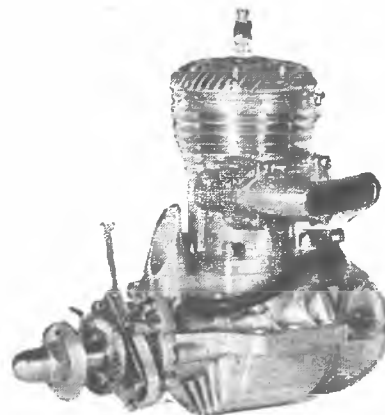

A LOT
OF ENGINE
FOR
\$24.95

Less Coil and Condenser (Includes plastic gas tank for free flight)

ANDERSON
Spitfire

SPITFIRE SPECIFICATIONS

TYPE—Two port, two stroke cycle, air cooled.
FUEL ADMISSION—Through ball bearing mounted rotary crankshaft valve.
CARBURETOR—Tangent down-draft. Spray bar suction type.
BORE— $\frac{15}{16}$ ". STROKE— $\frac{7}{8}$ ". COMPRESSION RATIO—6:1.
PISTON DISPLACEMENT—601 cu. in. or 10 cubic centimeters.

IMMEDIATE DELIVERY—WIRE—WRITE

MANUFACTURED AND GUARANTEED BY

MEL ANDERSON MFG. CO.

1819 Third Ave.
Los Angeles 6, Calif.

"O.K." HIGH-VOLTAGE COILS

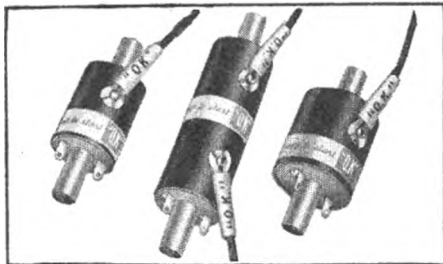

FASTER STARTS LONGER BATTERY LIFE

"O.K." High-Voltage Coils bring proven better performance to any miniature ignition type engine. Flight check starts and laboratory tests reveal they contribute positively to easier, faster starting and longer battery life. Pack a load of reserve power that pays off on the flight line. Made only of the finest materials, they have a clean, perfect finish with lifetime sealed end coverings. Every coil is tested and guaranteed. Sold complete with necessary high tension leads.

Coil A for A and B class engines.....\$2.50
Super-Coil C for B and C class engines.....\$2.50
Twin Coil for two-cylinder engines.....\$5.00

MATCHED CONDENSERS

Strength and freshness assured as they are hermetically sealed in moisture-proof Bakelite cases. 200V for single cylinder engines.....25c
400V for two-cylinder engines.....35c

SOLD BY LEADING DEALERS

HERKIMER TOOL & MODEL WORKS, Inc.
Herkimer, New York

GET A SHOW JOB

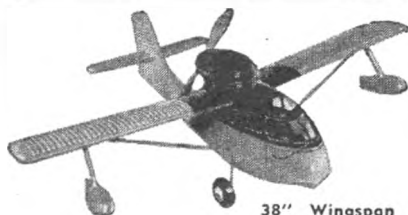

38" Wingspan
Scale 1" to 1"
For "C" Engines

Be the first in your city to own and fly the Seabee. You can quickly assemble. No experience required. Just follow the 33 simple, step-by-step Production illustrations. Complete hardware furnished. Note corrugated wing and tail surfaces. Plexiglas windows, detachable motor hood, retractable landing gear. Only kit with all exterior parts of pre-formed Phenopreg—sturdy, tough, durable and water-tight. U-Control, Jim Walker's U.S. Pat. No. 2,292,416. DEALERS WRITE.

If your dealer can't supply, send coupon today. Satisfaction guaranteed—if not pleased, return kit in 10 days and money will be returned promptly.

\$1450

MONEY BACK OFFER

THOMAS ASSOCIATES • 207 W. Palm, Burbank, Calif.

Enclosed find \$1.00—I will pay Postman \$13.50 plus parcel post charges

Enclosed find \$14.50 (check or money order) Please ship kit with parcel post prepaid

Send descriptive folder free

Name

Address

City Zone State

RR' when banking under the influence of the pressure at the high center of lateral area. The combination of these rolling motions causes the plane to nose down.

You can readily determine this by holding an airplane at a low point at the nose and a high point at the rear, then rolling it sideways with your fingers without moving the position of your hands. You will note that the nose points downward. This is exactly what happens to Mr. Brown's airplane when it is in flight. It banks sharply due to the high C.I.A., noses down due to the high fin and downward slant of DD', and then proceeds on its merry way into a sudden left spiral. Because it noses down the speed increases. This causes a tighter spiral, and the tighter the spiral the greater the speed. Consequently, each effect builds up on the other until a crash results.

Mr. Brown can cure his troubles by doing one of two things. He can slant the thrust line down (relative to fuselage axis) and change the angle of wing and stabilizer, as shown in Fig. 3. In doing so he must be sure to raise the movable weights, such as batteries, coil, timer, etc., upward, so the CG will be raised and located on a horizontal line passing through the CLA or near it, as in Fig. 3. This line is parallel to the thrust line. This is not the best arrangement, however. Much better results will be obtained if the thrust line is raised to the position shown in Fig. 4, which is the most stable setup, because all points are on the thrust line. This raises the CG to the level of the CLA without the necessity of changing the angles of wing and stabilizer. It also brings the thrust line on a line with the CG or above it. The latter condition creates a tendency against looping at steep climbing angles, by producing a counter-clockwise corrective moment in combination with the downward pull of the CG.

Our readers will be greatly interested, I am sure, if Mr. Brown carries through these changes and writes to tell us of the results.

It is strange but true that the significance of lateral area effects has not even been realized by large airplane designers. Possibly this is due to the fact that pilots in large craft correct any deviation from normal flight with the controls before their planes reach critical positions that might demonstrate the significance of the lateral area factor. It was not until the Army attempted the design of pilotless aircraft that they encountered difficulties with spiral instability. To the consternation of those opposed to this theory, its application in the case of the Army corrected their troubles and pioneer research men are beginning to realize more and more the value of placing vertical areas or surfaces forward and below the CG in order to locate the CLA, on a line with the CG. Placing more area forward also makes it possible to use larger fins and thereby gain greater directional stability, because there is a definite proportion between the size of the fin and side area forward at the CG. The more area forward relative to the fin size the less the nose will drop before recovery forces react to restore lateral equilibrium and in this way reduce spiral diving tendencies. With the CLA in the right position, banking will be very small and therefore the nose will have little tendency to drop regardless of fin size. However, a small fin allows restoring forces plenty of time to do their work properly before the nose drops dangerously.

HI-THRUST PROPS

Perfect air-foil section for higher speeds and longer flights. Sharp, clean edges. Beautiful natural wood finish, with pitch and diameter stamped on hub.



NEW 1948 PRICE LIST

Dia.	6" or 8" Pitch	10" Pitch
8, 9, 10, 11"	50	60
12, 13, 14"	60	70
7-3 and 8-3 Propellers	35c	

Write for Inventory Check List

Thousands of Hobby Craft and Model Builders' Items

WHOLESALE ONLY

R. L. WEBBER CO.

4024-26 ELSTON AVE. CHICAGO 18, ILL.

DOUGLAS DC-6

This postwar airliner has had accessory trouble, but it will soon be flying again in full force. Read the story of its development, its recent troubles, and how they have been completely overcome—in May MODEL AIRPLANE NEWS. . . . On Sale Everywhere April 9th.

BUILD THESE

Early

Frontier
MODELS

FULL-SCALE • READY TO ASSEMBLE • MADE OF PLYWOOD • FULLY MOVABLE
Stage Coach . . . 13" long
Chuck Wagon . . . 13" long
Beer Wagon . . . 13" long
Ox Cart . . . 9" long

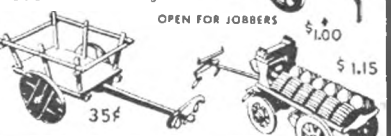

FRONTIER NOVELTY Mfg. Co.
735 Aragon Ave., Los Angeles 31 Calif.

NEW TANK! MAECO-SUPER

Specially designed for large luxury motors. Holds 2.4 ozs. Size: 2 1/2 x 2 x 1. Sturdy but light all-brass construction. Uses same proven CON-STANT-FLOW principles as STANDARD.

Ready to install.....\$1.25 Kit Form.....80c

MAECO STANDARD TANK:

Brass construction for all types of fuel. Over 11,000 in actual use. Holds 1.9 ozs. Size: 2 x 2 x 1. Demand MAECO'S ORIGINAL and flight tested. STURDY TANKS. Glad to report that the original price is back. Ready to install.....\$1.00 Kit Form.....75c



MAECO STOOGE

Only 35c

The release that helped Don Gulotta win the NATIONAL SENIOR ACROBATIC CHAMPIONSHIP. Makes one-man control flying possible with ease. Note its low price. Try it today!

See your dealer first. (Mail orders Postpaid.)
Inquiries from DEALERS and DISTRIBUTORS INVITED
(Calif. residents add 2 1/2% sales tax.)

MODEL AERO ENGINEERING CO.
P.O. Box 1053, Magnolia Park Sta., Burbank, Calif.

We are not overlooking our U control modelers this month. Val Rich of Montpelier, Idaho sends us a very interesting suggestion. He believes in progress and not in merely swinging an airplane around at the end of a string for the sake of hearing the engine turn over. He suggests, and very wisely, that U control fliers use their hobby for experimenting. Perhaps some have realized that within their grasp they have an excellent instrument to test different wing forms, body shapes and aerodynamic combinations. For instance, a series of tests could be run to determine the most advantageous form of wing for any particular type of flight. Some wings will be faster; others will give greater lift.

Mr. Rich suggests that you construct a special fuselage with engine and landing gear to mount detachable wings for testing. Then make a set of wings with a known and definite airfoil section and with considerable area. Test runs should be made to determine the plane's takeoff run and high speed. If your craft shows plenty of zip and climbing ability during tests, cut down the wingspan and area little by little, testing the plane after each time you trim the wing, until finally you have just enough area to lift the airplane from the ground without excessive climb. On each test, the takeoff run should be measured and the high speed clocked. For your first wing section we suggest Fig. 5-A. This will be very fast. By running the tests as described, you can determine the minimum area that will fly your plane; also by weighing your airplane you can find out exactly what this wing will lift per sq. ft.

If you keep accurate records of your test data you will find them invaluable in working out designs of future airplanes, both U control and free flight.

The second series of tests might be made with a wing having a crosssection similar to Fig. 5-B. This wing should have the same span, area and outline as the original wing with crosssection A. Place wing B on your fuselage and run through the same tests as you did with A. Measure the takeoff run and determine the high speed, endeavoring in each case to fly the plane under the same conditions and in the same way as in tests with wing A. In this way you can determine the relative speeds and lifting effect of the two wings. These tests will also tell you which wing is better for your speed models. It is possible that wing B will lift more than A, and because of this less area can be used, with the final result that the airplane with wing B will have less drag than with A.

Fig. 5-C indicates another interesting crosssection for testing. This has an undercamber as well as an upper, with the undersurface bellied down slightly and then upward as it sweeps rearward from the leading edge. This downward bulge is called a "Phillips Entry" and reduces drag often caused by undercamber. In fact, the wing crosssection given in C, is highly efficient, and when the wing is shaped in this manner from balsa it will give even better results in free flight than built-up wings. They are especially adaptable to planes with CO. engines. Planes having balsa wings with this crosssection were flown out of sight as long ago as 1919.

You will probably find that this undercambered wing is not suitable for high speed control line jobs but may prove quite satisfactory for control line stunt planes. Without question its lift coefficient is higher than either A or B, and the plane therefore will take off sooner

NOW ONLY \$9.95 (REDUCED FROM \$15.00)

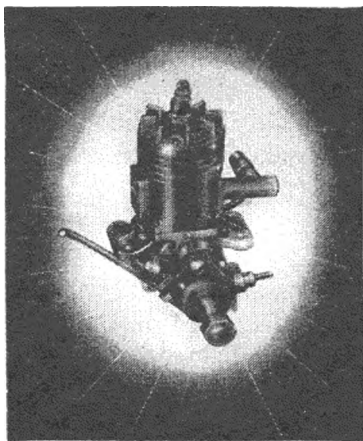

WITH THESE EXTRAS

Complete with coil, condenser, full instructions, spark plug, tank, aluminum propeller, ignition wire, coil holder, presto starter and copy of 50 page Gas Engine Theory & Practice Book.

Here is your opportunity to buy the 1948 model of the famous G. H. Q. Gasoline Motor. **ABSOLUTELY COMPLETE WITH COIL & CONDENSER**, etc.—Every engine assembled by experts, fully bench run and unconditionally guaranteed.

AN ENGINEERING TRIUMPH

Never Before at So Low a Price!

Indeed an engineering triumph—accomplished by outstanding G. H. Q. designers and engineers, who have constructed into the G. H. Q. motor everything that years of exhaustive scientific aerodynamic research could produce—geared to the highest possible degree of perfection. But more than that, the acid test . . . an overwhelming response. Thousands of users in all parts of the country

are praising, recommending, and endorsing this scientific achievement. It seems as if everyone in America wants one. The most hair-raising thrill you've ever experienced will be yours with the G. H. Q. motor—actually one of the most powerful motors ever constructed. Has broken records for amazing performance . . . and just imagine—flies model planes from 4 to 30 foot wingspread. AND JUST AS EFFICIENT FOR BOATS, MIDGET CARS AND STATIONARY USE. Easy to start and simple to run.

KIT OF FULLY MACHINED, READY-TO-ASSEMBLE PARTS. ONLY A SCREWDRIVER NEEDED . . . \$4.95 COIL & COND. \$1 EXTRA

OVER 100,000 IN USE TODAY!!

FREE Send for free Jumbo catalog of hundreds of model engine, plane, boat, car and hobby items.

SPECIFICATIONS

4 Port 2 Stroke Cycle. 3/4" Stroke. 15/16" Bore. 300-7,000 R.P.M. Bearing Surface 1/4" Long. Crankshaft, 5/16" Diam. Rotation, Either Direction. Invertible. 1/5" H.P. Class C under NAA Rules.

SEND ONLY \$1.00

Shipped Collect
C. O. D. Same Day

or send full amount and we ship prepaid and insured.

G. H. Q. MOTORS, DEPT. M-48, P. O. BOX 193, STA. O, N. Y. 11, N. Y.

Tiger

Makes Any Model Engine Perform Better!

Tiger is way out in front in model engine operation. Ask your dealer for the new Tiger Glo-fuels—A and B for ignitionless operation, or the old stand-by, Tiger regular 3 to 1 blend. See the brand new needle valves for precision engine control with the new fuels, and get a Tiger Fuel Pump to save gas, time and trouble—today.

Super-Glo Fuels

Super Glo—A. Petroleum base, pints, 75c
Super Glo—B. Methanol base, castor oil fortified. Pints \$1.00



FUEL PUMPS 69c

Fits Standard Pint Can

Jobbers Write Today



Tiger
New and Improved
NEEDLE VALVES
35c-50c-75c

Tiger GLO-FUELS

A and B
For Ignitionless Operation with Glo-Plugs
75c and \$1.00

BETTER NEEDLE VALVES

Not ordinary needle valves, but precision milled and machined for hair-line precision. Four styles, rigid and flexible. New DeLux type with positive ratchet lock.

TIGER PRODUCTS CO., 13014 Baltimore Ave., Chicago

X-CELL

*X-Cell's New Custom
Two Blade Propeller*

Give your model increased performance with the finest propeller made!

8" diam., 8", 10", 12" and 14" pitch. 9" diam., 8", 10", 12" and 14" pitch. 10" diam., 8", 10", 12" and 14" pitch. 11" diam., 8", 10", 12" and 14" pitch.

60¢ each

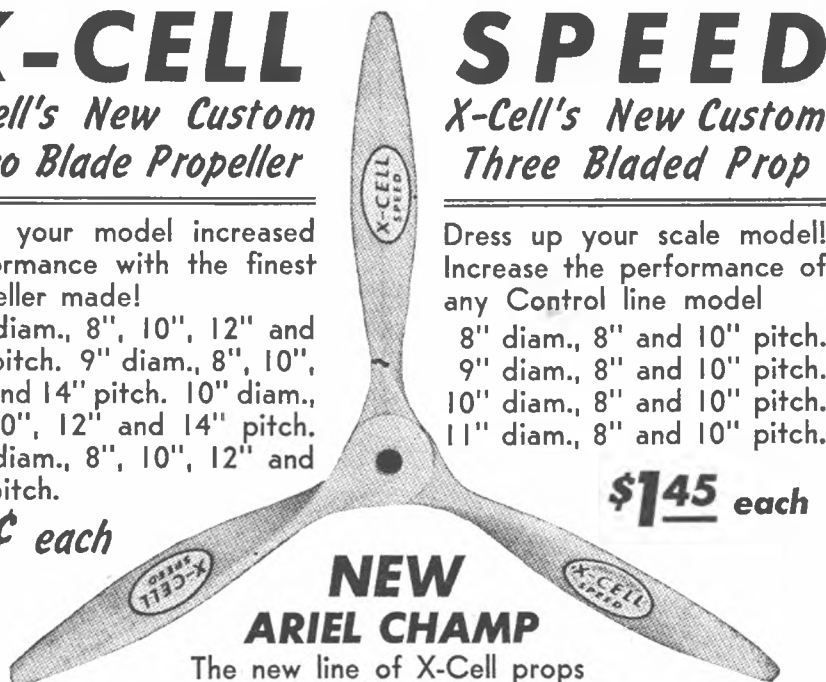

NEW ARIEL CHAMP

The new line of X-Cell props

Made with the same degree of perfection

But lacking the strength and finish of the "SPEED" line.

8", 9", 10" and 11" diameter

8", 10" and 12" pitch

40¢



40¢

X-CELL MANUFACTURING COMPANY

6243 So. Manhattan Pl.

Los Angeles 44, Calif.

**At Long
Last...**

A PRACTICAL JET ENGINE

**EVERY MODEL
BUILDER CAN
AFFORD TO OWN**

The new M.E.W. 601 engine costs you practically nothing to build. In fact, most modelers will already have all the necessary parts and materials required to build this engine... a discarded CO₂ cylinder for a compression tank plus a few odd pieces of metal found in most scrap boxes. Entire jet engine can be built quickly and easily with ordinary hand tools. Small amount of welding is necessary.

The M.E.W. 601 engine runs from three to five minutes. Uses gasoline for fuel. Is easy to start... requires no ignition or external starting apparatus. Copyrighted plans for the M.E.W. 601 are fully illustrated and easy to follow. Complete plans only \$1.00 postpaid. No CODs please.

MINNESOTA ENGINE WORKS
DIVISION OF CENTRAL ELECTRIC COMPANY
387 UNIVERSITY AVE. • ST. PAUL 3, MINN

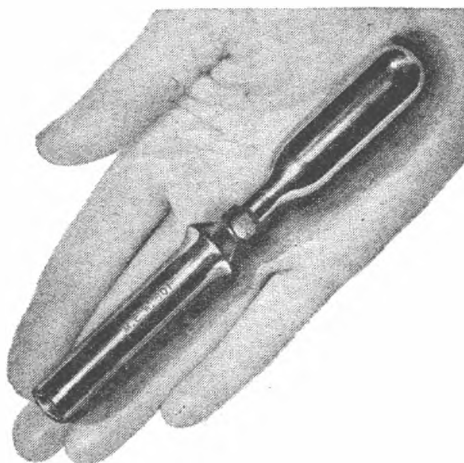

SPEED

*X-Cell's New Custom
Three Bladed Prop*

Dress up your scale model!
Increase the performance of
any Control line model

8" diam., 8" and 10" pitch.
9" diam., 8" and 10" pitch.
10" diam., 8" and 10" pitch.
11" diam., 8" and 10" pitch.

\$145 each

but probably will fly slowly. If your plane has considerable power we suggest you make this thin wing of a harder wood instead of balsa—for instance, pine.

We received many letters from our readers and endeavored to answer them either in the articles or by letter. We have found it impossible to answer all letters sent to us. Though you may not hear from us, please understand that we appreciate your contributions. We will make brief comment about a number of them without going into much detail.

H. N. Barker of Mineola, L.I., sends us specifications of an original free flight model for criticism. He lists its specifications as follows:

Clark C-10 airfoil
Wing loading—70 ozs. per 100 sq. in.
Power loading—123.75 ozs. per cu. in.
Engine—DeLong "30"
Wing Area—527 sq. in.
Stabilizer Area—110 sq. in.
Rudder area—19 sq. in.
Weight—37 ozs.
Thrust line—Zero, 3° right thrust, incidence of wing plus 3°,—Stabilizer=Zero

A side view sent by Mr. Barker shows the CLA high and the CG low. To correct this, the engine should be raised as in Fig. 4 which in turn will raise the CG to a point on a line with the CLA.

The specifications given above may be improved considerably. For instance, the stabilizer area should be at least 158 sq. in.—that is, 30% of wing area. The rudder area should be 27 to 37 sq. in., at least 5% of wing area. The plane would be highly unstable with the areas specified.

P. E. Markle of Pittsburgh desires a method for calculating the center of gravity, stagger and general proportions for a model biplane. This is a large order; a book can be written on these subjects, and in fact several have been. We suggest that Mr. Markle look through the pages of various model airplane books.

Donald Stripko of Keansburg, N. J., wants us to comment on a sketch of a control line plane he sent. It is of orthodox design. The specifications are:

Wing span—16"
Fuselage—20"
Power Fox .59 Engine
Propeller—diameter 8"
Pitch—2"

The wingspan suggests that the total area does not exceed 70 sq. in. With the specified engine this should be a minimum, and it is a question whether or not the airplane will rise off the ground with this small amount of area without assistance through the guide wires. This area is the minimum that should be used with a .6 engine.

The only other highly critical factor in a control line plane is the propeller. Mr. Stripko has chosen well in this case. An 8" diameter and 12" pitch should give very high speed. The blades on such a propeller should be approximately 3/4" to 1" wide maximum with rounded tips. Pointed tips only absorb power without delivering proportional thrust.

We hope that other readers will send in new designs for criticism and any questions which may be puzzling them.

The answers to many questions sent us in the past are given in **MODEL AIRPLANE DESIGN AND THEORY OF FLIGHT** by Charles Hampson Grant, a 528 page book published by Air Age Inc. (551 Fifth Ave., New York 17). We suggest that those who are seriously interested in the science of model aeronautics obtain a copy of this work.

X-CELL

*X-Cell's New Custom
Two Blade Propeller*

Give your model increased performance with the finest propeller made!

8" diam., 8", 10", 12" and 14" pitch. 9" diam., 8", 10", 12" and 14" pitch. 10" diam., 8", 10", 12" and 14" pitch. 11" diam., 8", 10", 12" and 14" pitch.

60¢ each

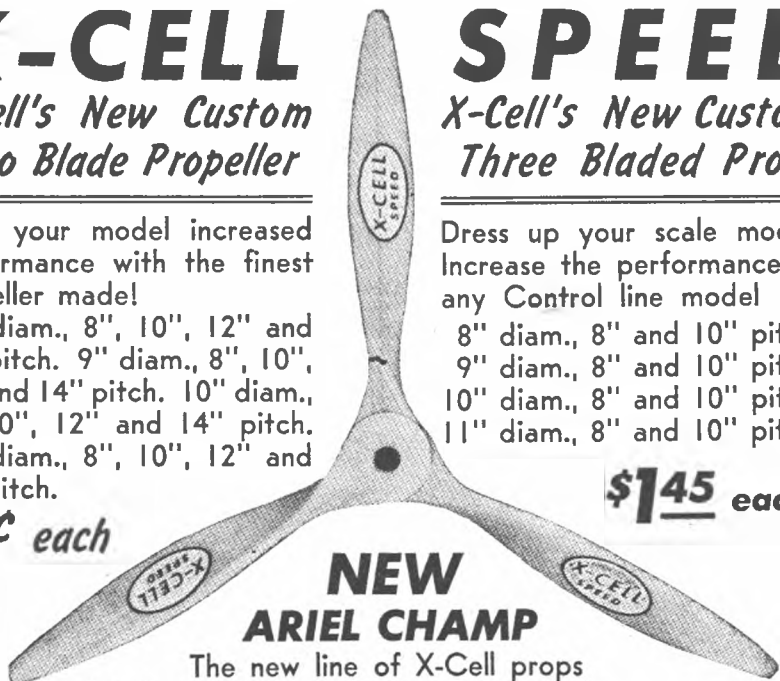

SPEED

*X-Cell's New Custom
Three Bladed Prop*

Dress up your scale model! Increase the performance of any Control line model

8" diam., 8" and 10" pitch.
9" diam., 8" and 10" pitch.
10" diam., 8" and 10" pitch.
11" diam., 8" and 10" pitch.

\$1.45 each

NEW ARIEL CHAMP

The new line of X-Cell props

Made with the same degree of perfection

But lacking the strength and finish of the "SPEED" line.

8", 9", 10" and 11" diameter

8", 10" and 12" pitch

40¢



40¢

X-CELL MANUFACTURING COMPANY

6243 So. Manhattan Pl.

Los Angeles 44, Calif.

At Long
Last...

A PRACTICAL JET ENGINE

EVERY MODEL
BUILDER CAN
AFFORD TO OWN

The new M.E.W. 601 engine costs you practically nothing to build. In fact, most modelers will already have all the necessary parts and materials required to build this engine... a discarded CO₂ cylinder for a compression tank plus a few odd pieces of metal found in most scrap boxes. Entire jet engine can be built quickly and easily with ordinary hand tools. Small amount of welding is necessary.

The M.E.W. 601 engine runs from three to five minutes. Uses gasoline for fuel. Is easy to start... requires no ignition or external starting apparatus. Copyrighted plans for the M.E.W. 601 are fully illustrated and easy to follow. Complete plans only \$1.00 postpaid. No CODs please.

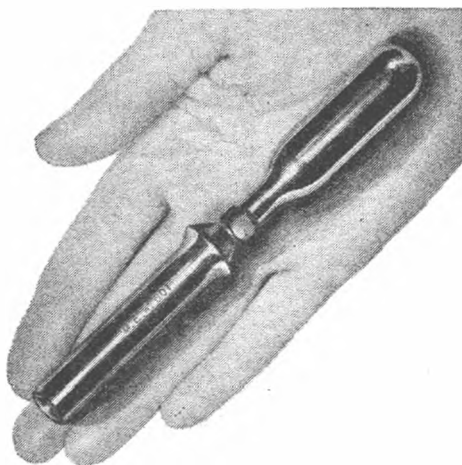

MINNESOTA ENGINE WORKS
DIVISION OF CENTRAL ELECTRIC COMPANY
387 UNIVERSITY AVE. • ST. PAUL 3, MINN

but probably will fly slowly. If your plane has considerable power we suggest you make this thin wing of a harder wood instead of balsa—for instance, pine.

We received many letters from our readers and endeavored to answer them either in the articles or by letter. We have found it impossible to answer all letters sent to us. Though you may not hear from us, please understand that we appreciate your contributions. We will make brief comment about a number of them without going into much detail.

H. N. Barker of Mineola, L.I., sends us specifications of an original free flight model for criticism. He lists its specifications as follows:

Clark C-10 airfoil
Wing loading—70 ozs. per 100 sq. in.
Power loading—123.75 ozs. per cu. in.
Engine—DeLong "30"
Wing Area—527 sq. in.
Stabilizer Area—110 sq. in.
Rudder area—19 sq. in.
Weight—37 ozs.

Thrust line—Zero, 3° right thrust, incidence of wing plus 3°,—Stabilizer=Zero

A side view sent by Mr. Barker shows the CLA high and the CG low. To correct this, the engine should be raised as in Fig. 4 which in turn will raise the CG to a point on a line with the CLA.

The specifications given above may be improved considerably. For instance, the stabilizer area should be at least 158 sq. in.—that is, 30% of wing area. The rudder area should be 27 to 37 sq. in., at least 5% of wing area. The plane would be highly unstable with the areas specified.

P. E. Markle of Pittsburgh desires a method for calculating the center of gravity, stagger and general proportions for a model biplane. This is a large order; a book can be written on these subjects, and in fact several have been. We suggest that Mr. Markle look through the pages of various model airplane books.

Donald Stripko of Keansburg, N. J., wants us to comment on a sketch of a control line plane he sent. It is of orthodox design. The specifications are:

Wing span—16"
Fuselage—20"
Power Fox .59 Engine
Propeller—diameter 8"
Pitch—2"

The wingspan suggests that the total area does not exceed 70 sq. in. With the specified engine this should be a minimum, and it is a question whether or not the airplane will rise off the ground with this small amount of area without assistance through the guide wires. This area is the minimum that should be used with a .6 engine.

The only other highly critical factor in a control line plane is the propeller. Mr. Stripko has chosen well in this case. An 8" diameter and 12" pitch should give very high speed. The blades on such a propeller should be approximately 3/4" to 1" wide maximum with rounded tips. Pointed tips only absorb power without delivering proportional thrust.

We hope that other readers will send in new designs for criticism and any questions which may be puzzling them.

The answers to many questions sent us in the past are given in **MODEL AIRPLANE DESIGN AND THEORY OF FLIGHT** by Charles Hampson Grant, a 528 page book published by Air Age Inc. (551 Fifth Ave., New York 17). We suggest that those who are seriously interested in the science of model aeronautics obtain a copy of this work.

AT LAST! WHAT MODELERS HAVE LONG NEEDED!

An Up-to-Date Manual & Reference Book on Model Motors!

THERE has been a growing need for a complete, up-to-date manual and reference book on model motors to aid model builders in the intelligent use of their powerplants. MODEL MOTOR MANUAL was long and carefully planned to fill this need!

The publishers commissioned LOUIS GARAMI, widely recognized as the top expert in the field of miniature engines, in collaboration with HOWARD McENTEE (Editor of *Model Airplane News* magazine), to amass all the essential material for such a comprehensive volume. Alan Orthof, one of America's outstanding aeronautic draftsmen, was also engaged to illustrate this book with his exceptionally fine drawings.

The combined efforts of these technicians have produced one of the most authoritative and useful books in the history of model activity!

The reader is first given a thorough explanation, by text and illustration, of the function of the model motor and the ignition system. Then he is made acquainted with the actual mechanical design features now used in commercial engines, and with the manufacturing processes that produce these units—such as grinding, milling and lapping.

The authors departed from the traditional method of classifying motors by number of ports employed—they found it more logical to identify them by the means used to bring fuel into the cylinder. The practicability of this new method is proved by the fact that although many new motors have reached the market all fit readily into the categories described in Chapter 5.

Besides a comprehensive coverage of every phase of model motor operation, this new book presents helpful tables, charts and data, and a large photograph section of: American gas, jet and diesel engines, as well as Foreign diesels.

Technical terms are avoided whenever possible, for this book is intended for the beginner as well as the expert, both of whom will find it an invaluable aid in the intelligent use of their powerplants!

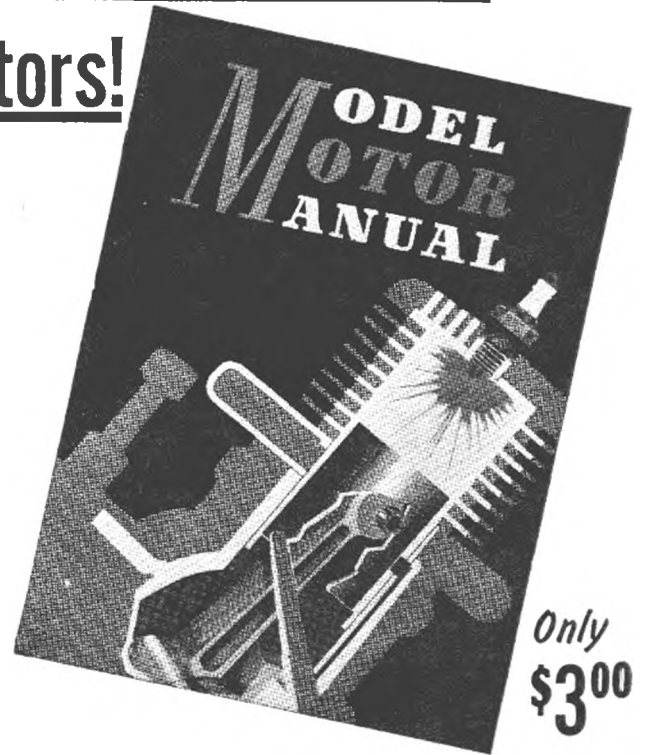

CONTENTS

Basic Principles of the Model Motor	Care of the Motor
Operation of the Model Motor	The Flight Timer
The Ignition System	The Propeller
Fuel, Lubricant and Carburetion	Engine Operation (Oil and Gas)
Types of Model Motors	A Simple Engine Test Mount
Engine—Upper Half	Home and Factory Repair
Engine—Lower Half	Making Accessories
Ignition Timers	Testing for Performance
The Sparkplug	Testing Plane Performance
Coil and Current	Four-Cycle Motors
Wires and Connections	Diesel Motors
Starting the Engine	Multi-Cylinder Motors
Trouble Shooting	Model Motors of the Future
Compression	Choice of Motor
Advancing and Retarding the Spark	Appendix
Trouble Shooting After Installation	Index

MODEL MOTOR MANUAL is no small booklet—it is beautifully bound in cloth and gold stamped . . . contains 228 pages, 6 x 9 inches . . . 112 highly skilled detailed drawings and photographs. Get your copy of this limited first edition from your favorite model shop—if he cannot supply you, order direct from publisher.

-----Mail This Coupon Today!-----

AIR AGE INC.
551 Fifth Ave., New York 17, N.Y.

Please send me postpaid a first edition copy of your new book MODEL MOTOR MANUAL, for which I enclose herewith \$3.00 (Outside U.S.A. \$3.25.)

Name

Address

City..... Dist. No. State

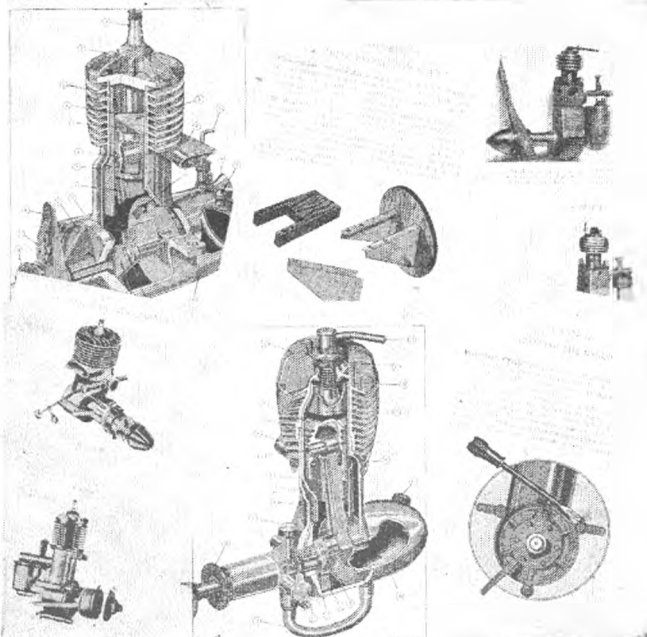



YOUR WINNER!

Paul Bender with less than two months experience in stunt flying won the Columbus, Ohio Meet with his "Super-Zilch" on its tenth flight. Two weeks later he won the Ohio State Championship with the same model on its 17th flight!

"LIL' ZILCH"

36" WINGSPAN —

For .19 to .36 Engines

Little Brother to the "Super-Zilch." A remarkable complete low price kit, including complete hardware.

\$2.95

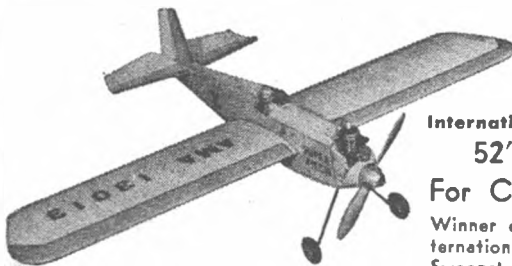

"SUPER-ZILCH"

International Stunt Champion
52" WINGSPAN

For Class "C" Engines

Winner of the First Plymouth International Meet, Grand Western Sweepstakes, and eleven other major stunt contests.

COMPLETE "DELUXE" KIT **\$4.95**

"BUSTER"

24" WINGSPAN —

For .19 to .36 Engines

1 1/2" Scale Model of 1947 Goodyear Trophy at National Air Races. Complete Standard Kit.

\$2.50



The New BERKELEY CATALOG

Big 8 1/2" x 11" Book, loose leaf bound, listing hundreds of model kits, supplies and accessories. New sheets mailed three times during the year. At your dealer or print your name and address and enclose \$2.50 in coin and mail to above address.

25¢

Hawker Super Fury

24" Wingspan 3/4" scale. For .09 to .23 engines with genuine "U" Control Elevator and "Autotrol" Rudder.

\$2.50

at better dealers everywhere

BERKELEY MODELS INC.

140 GREENPOINT AVE. • BROOKLYN 22, N. Y.

EXPORT OFFICE: 120 WALL ST., N. Y. C.
CABLE ADDRESS: CONCORDIA, N. Y.

Index to ADVERTISERS in this Issue

Ace Model Airplane Co.....	3rd Cover
Aeramarine Co.....	57
Aero Spark Co.....	62
Air-O-Model Supply Co.....	56
America's Hobby Center.....	6, 7
American Hobby Specialties, Inc.....	65
Mel Anderson Mfg. Co.....	67
Atlantic Aircraft Inc.....	3
Atwood Mfg. Co.....	53
Austin-Craft.....	58
Berkeley Models, Inc.....	54, 72
Bropar Distributors.....	66
Cal-Aero Technical Institute.....	5
Chem-L-Co Industries.....	44
Cleveland Model & Supply Co.....	36
Consolidated Model Engineering Co.....	58
Crescent Model Shop.....	59
deBolt Model Engineering Co.....	60
Drone Engineering Co.....	55
Duro-Matic Products Co.....	52
Dyna-Model Products Co.....	44
Eastern Supply Co.....	62
Experiment, Inc.....	66
Forster Brothers.....	43
Four Star Model Builders Supply.....	49
Francisco Laboratories.....	64
Frontier Novelty Mfg. Co.....	68
G.H.O. Motors.....	69
GMCO Modelcraft Hobbies.....	41
Gotham Hobby Co.....	42, 50
Great Lakes Models.....	46
H & H Model Motor Co.....	65
Herkimer Tool & Model Works, Inc.....	1, 68
Hobbycrafts.....	64
International Models.....	51
K & B Mfg. Co.....	51
Kirk's Hobby Hanger.....	50
Kramer Brothers Model Distributors.....	58
Lansco Model Aircraft.....	54
Leader Model Supply Co.....	54
Lucas & Smith Mfg. Co.....	48
Mart-Lee Mfg. Co.....	39
Master Modelcraft.....	60
Megow.....	52
Mercury Model Airplane Co.....	53
Merrystudy Publications.....	56
Micro-Bilt Corp.....	8
Micro Diesel Co.....	51
Minnesota Engine Works.....	70
Mite Distributing Co.....	39
Model Aero Engineering Co.....	68
Model Experiment Lab.....	48
Modelcraft.....	43
Mod-Kraft Co.....	38
Mohawk Engineering Co.....	34
Monogram Models, Inc.....	57
National Model Distributors.....	67
Northrop Aeronautical Institute.....	37
Ohlsson & Rice.....	Back Cover
Ole Reliable Models.....	50
Pierce Industries.....	45
Pine Watch Co.....	54
Phantom Motors Distributing Co.....	47
Plastic Wood.....	38
Polk's Model Craft Hobbies.....	46
Bob Roberts.....	64
Scientific Model Airplane Co.....	35
Sellely Mfg. Co.....	46
Sky Hobby, Inc.....	48
Skyway Modelcraft, Inc.....	63
Claude C. Slate Co.....	66
Nathan R. Smith Mfg. Co.....	47
Sparky Specialties, Inc.....	61
J. Spokane & Co., Inc.....	48
Sport-O-Speed.....	66
Victor Stanzel & Co.....	40
Sterling Models.....	60
Strombecker-Becker Mfg. Co.....	33
Super Cyclone, Inc.....	4
Super Motors, Inc.....	60
Testor Chemical Co.....	2d Cover
Thomas Associates.....	68
Tiger Products.....	69
Trim-Crafts.....	50
Trost.....	44
Tuttle Bros. Mfg. Co.....	54
R. L. Webber.....	68
X-Cell Mfg. Co.....	70

April 1948

MODEL AIRPLANE NEWS



**O.K. CO₂
ENGINE**
\$4.95

KITS for CO₂ Motor

Lancer	\$1.00
Thermalier	\$1.00
Topper A	\$1.00
Circle King	\$1.00
Fleetster	\$1.25
Powerhouse	\$1.50

Add 15c postage

**Toy
Jet Bulbs**

Specially made for jet race cars, planes and boats. **EXTRA HEAVY CHARGE** at no extra price! **\$1.00**
Box of 10



**UNGAR ELECTRIC
SOLDERING PENCIL**

Light, handy well-balanced. Heats in 90 seconds. For delicate precision work or heavy duty jobs.
Plastic handle with 6 ft. cord \$1.00
Interchangeable pyramid chisel and pencil tips and wood burning pencil tip. \$1.00 ea.
Standard 230 Watt 1 Point Iron \$2.25
Standard 230 Watt 3 Point Iron 3.00
#050 Woodburning Pen90
#017 Woodburning Pen with 5 rolls foil 1.50
Ungar 6 in 1 Burning Pencil 2.00

SOLID WOOD MODEL KITS
Add 15c postage

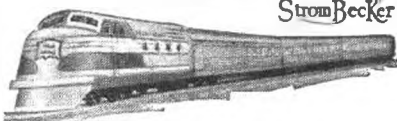

ROCK ISLAND ROCKET

Fits standard HO gauge model layouts. Scale 1/8" to 1". Complete kit with instructions \$1.50
Power trucks can be added to operate as electric train!

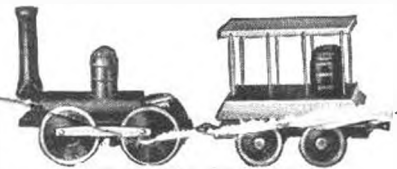

DEWITT CLINTON

(as illustrated)	\$1.50
DeLuxe Model	\$1.00
William Galloway	\$1.50
DeLuxe Model	\$1.00

SPECIAL! 1/3 OFF

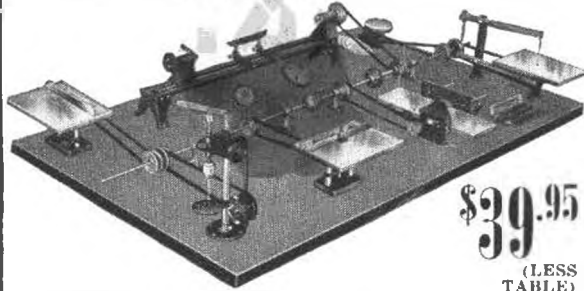

\$39.95
(LESS TABLE)

Complete Home Workshop. Regular \$59.50 Workshop. Just 65 left. Save almost \$20—while they last.

Taylor Hobbycraft Power Tools

Precision tools for your model and hobby work. You can now buy these tools separately, as well as in the money-saving workshop combinations. Expertly designed for craftsmen.

Jig Saw and 13 blades	\$ 4.95
Lathe 2 1/2" bed, 4" face plate, 3" grinding wheel, grinding wheel adapter	10.95
Jointer with 4" steel knives	10.95
Circular Saw, combination rip and cross cut blade	7.95
Drill Press, drill chuck	6.95
Shaper, blade, rubber belt	7.95
Disc Sander, 8" Horizontal Table	2.15
Belt, endless rubber, 25" long	.25
Blades for Jig Saw, standard 13", per doz.	.50
Blades for Circular Saw, combination rip and cross cut 4"	.75
Blades for Jointer, 4", case hardened, per pair	1.00
For Shaper—steel, case hardened	1.00
Couplings, flexible, 1/4" bore, die cast with set screws	.75
Sand paper discs, for sander 8" dia., per doz.	.60
Collars, for line shafts, per pair	.30
Face Plate for lathe, 4 1/2" swing	.75
Grinding Wheel, 3" dia.	.90
Hangers for line shaft, 3 for	1.00
Line Shaft Sections 30" long, 1/2" dia.	.30
Chuck for Drill Press, spring action tool steel jaws. For any drill, round or square shank up to 1/2" dia.	1.00
Pulley, die cast, 2 1/2" O.D., with set screw	.50

KING KUT HOBBY KIT No. 120



Contains Handle and 22 cutting edges for every purpose. Packed in sturdy carton with place for each tool. **\$5.00**
No. 100 King Kut Knife and Blade \$1.00
No. 110 King Kut Knife and 6 Blades \$1.75
No. 112 Knife, Router and Saw Set \$2.50

BOEING B-20 Super Fortress



42-inch Flying Scale Model. Assembly line construction makes it easy to build. Balsa wood **\$2.00**

Megow Erroupe	\$2.00	Megow Spitfire	\$2.00
Megow Sky-cycle	\$2.00	Megow Airacobra	\$2.00
Megow carcat	\$2.00	Megow Towline	\$2.00
Megow P 38	\$2.00	Megow Glider	\$2.00
Megow Ryan Fireball	\$2.00	Megow Taylor Cub	\$2.00

(Add 15c postage on order)

We can fill all your model and accessory needs from our unusually large stock. You can order any item advertised in this magazine from us. Immediate delivery.

**VIBRA-TAK
PRECISION
TACHOMETER**

What is the RPM output of your engine? Check its efficiency with the pocket size tachometer that gives RPM readings for all types of high speed equipment. Instant readings from 2,000 to 15,000 RPM
\$2.00

CONVERTIBLE

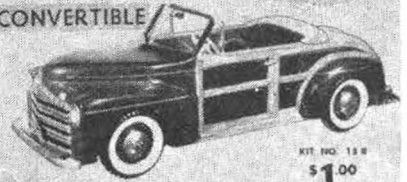

Convertible \$1.00
plus 15c postage

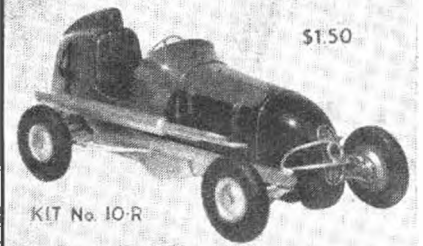

Midget Race Car \$1.50
plus 15c postage

MODEL KITS

S R Race Car	\$.60
Cornet M. Power	1.00
Sport Roadster	.60
Civilian Jeep	.60
Stage Coach	1.50
Covered Wagon	1.50
Horseless Carriage	1.50
Veco Racer	.95
Cavacraft	.60
Ace Racer	.35
Railway Express Truck	4.95
Trig Trucks	.75
Buildozer	1.00
Army Searchlight	1.00

JET RACECARS

Cornet Racer	\$.50
Jet Midget	.60
Hot Shot	.60
Jeto	.60
Starbird	.60
Jet Speedboat	.60
Super Jet	.75
Atomic	1.00
Terrajet	1.00
Hot Rod	1.00
Hot Rok	1.00
Rocket Jet Plane	1.00

On C.O.D. orders, please send 25% with order

ACE MODEL AIRPLANE COMPANY

"The Country's Oldest Hobby House"

3149 Shenandoah

ST. LOUIS 4, MISSOURI

Flash! . . . NEW IMPROVED OHLSSON & RICE GLOW PLUG 85c . . . NOW AT YOUR DEALER'S

Ohlsson & Rice

Are Producing Two New Model Engine Fuels

Why? All the years that we have been manufacturing model engines, Ohlsson & Rice have never recommended any engine fuel other than 3 parts gasoline and 1 part SAE 70 lubricating oil.

We were, of course, aware that many gas modelers were using the so-called "hot" prepared fuels. *Gas models are flown for fun, and the more power the more fun, thrills, and performance.*

However, it is common knowledge among engine manufacturers that these "hot" fuels as a class have been the major cause of all model engine troubles.

The reason is simple: Operating engines at high R.P.M. day in and day out requires high quality expensive lubricants which were simply not included in the average prepared fuel.

In a nutshell, the situation was this: Ohlsson & Rice engines, and other good engines, were capable of giving gas modelers consistent high speed performance. But the engine manufacturers' efforts were constantly being defeated, and the engines gummed up and otherwise damaged by inferior fuels. Producing in small quantities, the makers of these fuels were unable to use high grade materials and sell their fuels at a price which the average modeler could afford to pay.

WITH THE APPEARANCE OF THE GLOW-PLUG several months ago, it seemed for a time that perhaps the answer to dependable high speeds had been found: that the problem was not fuel, but ignition. However, whatever additional work may remain to be done on the glow-plug, it soon became apparent that here too fuels were falling down—that the glow-plug alone was not the answer.

For these obvious reasons—in order to protect our engines and give gas modelers the performance they were

entitled to, this company—as the world's largest model engine manufacturer—has for some time been studying high performance fuels and in particular high performance lubricants for two-cycle engines.

In carrying out the research, one of our first steps was to hire a competent chemical engineer to investigate all possible materials and develop fuels that would embody the latest findings of science.

NOW AFTER MONTHS OF WORK and the construction of a complete fuel processing plant, Ohlsson & Rice Fuel Laboratories is prepared to supply modelers not just one but two superior gas engine fuels—"supreme fuels for model engines." As a result of tests with every type of engine, both standard ignition and glow-plug, contest and pleasure, we are in a position to change our long-standing recommendation and invite gas modelers to try really "hot" model fuels.

In every way, Ohlsson & Rice fuel No. 1 and No. 2 are hot, hotter than any formula ever before offered to model builders! Together with superior combustion and power-producing characteristics, they also contain the most expensive lubricants ever used in such fuels.

So complete is the combustion and so clean-burning are these two fuels that they not only do not form carbon, sludge, and engine varnish, as do other fuels, but they actually remove and expel carbon, sludge and varnish that previously had been deposited.

LAST AND NOT LEAST, in spite of our sizable investment and the exceptionally high cost of the materials used, these fuels are offered at competitive prices, in line with Ohlsson & Rice's long-established policy of setting the "standard of the model world." Both fuels are available at your dealer's for immediate delivery



PINTS 75c
QUARTS \$1.40

Ohlsson & Rice No. 1 For Standard Ignition

A new formula containing special high performance lubricants and high quality fuel ingredients designed for use in any standard ignition engine. An ideal cool running fuel for sport flying. Easy starting, clean running, and cool operating. Supplies smooth power. Due to high grade ingredients used, it is recommended as break-in fuel for new engines.

Ohlsson & Rice No. 2 For Glow Plug

Methanol base in a new formula combining latest scientific fuel ingredients with special high performance lubricants. Easy starting, clean running, and cool operating, supplies steady smooth power. This fuel is recommended as a high speed racing fuel and can be used in engines having standard ignition if a fuel cut-off system is installed.



PINTS 75c
QUARTS \$1.40

OHLSSON & RICE, INC., Emery at Grande Vista, Los Angeles 23 • Standard of the Model World

DUNN & COMPANY, INC.
221 WEST 11TH STREET
LOS ANGELES, CALIF. 1938

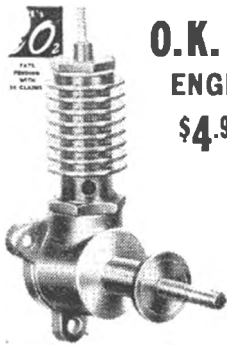

**O.K. CO₂
ENGINE**
\$4.95

KITS for CO₂ Motor

- Lancer\$1.00
- Thermalier\$1.00
- Topper A\$1.00
- Circle King\$1.00
- Fleetster\$1.25
- Powerhouse\$1.50

Add 15c postage

**Toy
Jet Bulbs**

Specially made for jet race cars, planes and boats. **EXTRA HEAVY CHARGE** at no extra price! **\$1.00**
Box of 10.....



**UNGAR ELECTRIC
SOLDERING PENCIL**

Light, handy well-balanced. Heats in 90 seconds. For delicate precision work or heavy duty jobs.

- Plastic handle with 6 ft. cord\$1.00
- Interchangeable pyramid chisel and pencil tips and wood burning pencil tip.....\$1.00 ea.
- Standard 230 Watt 1 Point Iron\$2.25
- Standard 230 Watt 3 Point Iron3.00
- = 050 Woodburning Pen......90
- = 047 Woodburning Pen with 5 rolls foil1.50
- Ungar 6 in 1 Burning Pencil2.00

SOLID WOOD MODEL KITS

Add 15c postage

StromBecker

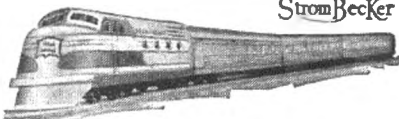

ROCK ISLAND ROCKET

Fits standard HO gauge model layouts. Scale 1/8" to 1". Complete kit with instructions\$1.50
Power trucks can be added to operate as electric train!

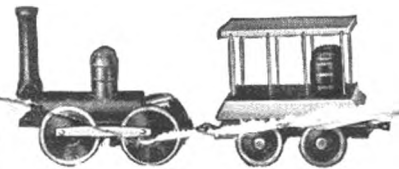

DEWITT CLINTON

- (as illustrated)\$.50
- DeLuxe Model\$1.00
- William Galloway\$.50
- DeLuxe Model\$1.00

SPECIAL! 1/3 OFF

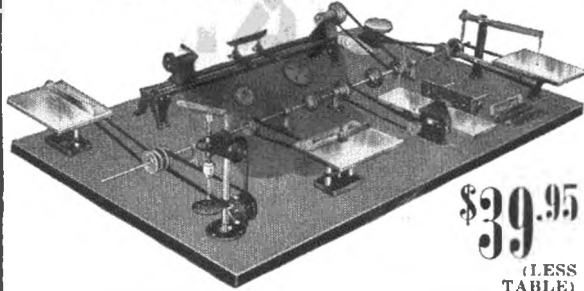

\$39.95
(LESS TABLE)

Complete Home Workshop. Regular \$59.50 Workshop. Just 65 left. Save almost \$20—while they last.

Taylor Hobbycraft Power Tools

Precision tools for your model and hobby work. You can now buy these tools separately, as well as in the money-saving workshop combinations. Expertly designed for craftsmen.

- Jig Saw and 13 blades.....\$ 4.95
- Lathe 2 1/2" bed, 4" face plate, 3" grinding wheel, grinding wheel adapter.....10.95
- Jointer with 4" steel knives.....10.95
- Circular Saw, combination rip and cross cut blade.....7.95
- Drill Press, drill chuck.....6.95
- Shaper, blade, rubber belt.....7.95
- Disc Sander, 6" Horizontal Table.....2.45
- Belt, endless rubber, 25" long......25
- Blades for Jig Saw, standard 6", per doz......50
- Blades for Circular Saw, combination rip and cross cut 4"......75
- Blades for Jointer, 1/2" case hardened, per pair.....1.00
- For Shaper—steel, case hardened.....1.00
- Couplings, flexible, 3/8" bore, die cast with set screws......75
- Sand paper discs, for sander 6" dia., per doz......30
- Collars, for line shafts, per pair......30
- Face Plate for lathe, 4 1/2" swing......75
- Grinding Wheel, 3" dia......90
- Hangers for line shaft, 3 for.....1.00
- Line Shaft Sections 30" long, 3/8" dia......30
- Chuck for Drill Press, spring action tool steel jaws. For any drill, round or square shank up to 1/2" dia.....1.00
- Pulley, die cast, 2 1/2" O.D., with set screw......50

KING KUT HOBBY KIT No. 120

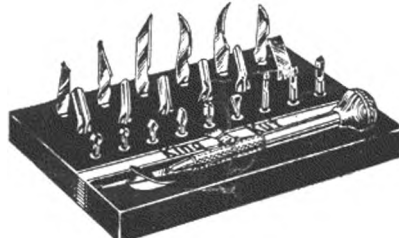

Contains Handle and 22 cutting edges for every purpose. Packed in sturdy carton with place for each tool. **\$5.00**

- No. 100 King Kut Knife and Blade\$1.00
- No. 110 King Kut Knife and 6 Blades\$1.75
- No. 112 Knife, Router and Saw Set.....\$2.50

BOEING B-29 Super Fortress

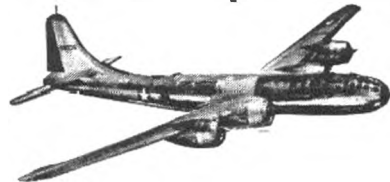

42-inch Flying Scale Model. Assembly line construction makes it easy to build. Balsa wood **\$2.00**

- Megow Ercoupe\$2.00
- Megow Sky cycle\$2.00
- Megow carcat\$2.00
- Megow P 38.....\$2.00
- Megow Ryan Fireball\$2.00
- Megow Spitfire\$2.00
- Megow Airsobra\$2.00
- Megow Towline Glider\$2.00
- Megow Taylor Cub.....\$2.00

We can fill all your model and accessory needs from our unusually large stock. You can order any item advertised in this magazine from us. Immediate delivery.

**VIBRA-TAK
PRECISION
TACHOMETER**

What is the RPM output of your engine? Check its efficiency with the pocket size tachometer that gives RPM readings for all types of high speed equipment. Instant readings from 2,000 to 15,000 RPM
\$2.00

CONVERTIBLE

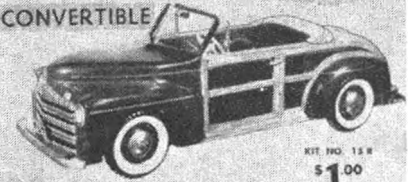

KIT NO. 15-R
\$1.00

Convertible\$1.00
plus 15c postage

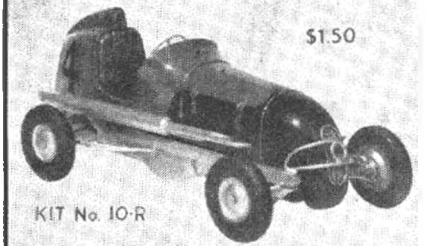

\$1.50

Midget Race Car\$1.50
plus 15c postage

MODEL KITS

- S R Race Car\$.60
- Comet M. Power1.00
- Sport Roadster......60
- Civilian Jeep......60
- Stage Coach.....1.50
- Covered Wagon.....1.50
- Horseless Carriage.....1.50
- Veco Racer......95
- Cavacraft......60
- Ace Racer......35
- Railway Express Truck.....4.95
- Ting Trucks......75
- Bulldozer.....1.00
- Army Searchlight.....1.00

JET RACECARS

- Comet Racer\$.50
- Jet Midget......60
- Hot Shot......60
- Jeto......60
- Bluebird......60
- Jet Speedboat......60
- Super Jet......79
- Atomic.....1.00
- Terrajet.....1.00
- Hot Rod.....1.00
- Hot Rok.....1.00
- Rocket Jet Plane.....1.00

On C.O.D. orders, please send 25% with order

ACE MODEL AIRPLANE COMPANY

"The Country's Oldest Hobby House"

31-19 Shenandoah

ST. LOUIS 4, MISSOURI