

OCTOBER 1951 - 25 CENTS

# MODEL AIRPLANE NEWS



**NATIONALS PICTURES AND WINNERS**

# Digital Edition Magazines.

This issue magazine after the initial original scanning, has been digitally processing for better results and lower capacity Pdf file from me.

The plans and the articles that exist within, you can find published at full dimensions to build a model at the following websites.

All Plans and Articles can be found here:

Hlsat Blog Free Plans and Articles.

<http://www.rcgroups.com/forums/member.php?u=107085>

AeroFred Gallery Free Plans.

<http://aerofred.com/index.php>

Hip Pocket Aeronautics Gallery Free Plans.

[http://www.hippocketaeronautics.com/hpa\\_plans/index.php](http://www.hippocketaeronautics.com/hpa_plans/index.php)

**Diligence Work by Hlsat.**



SPITFIRE MK-19

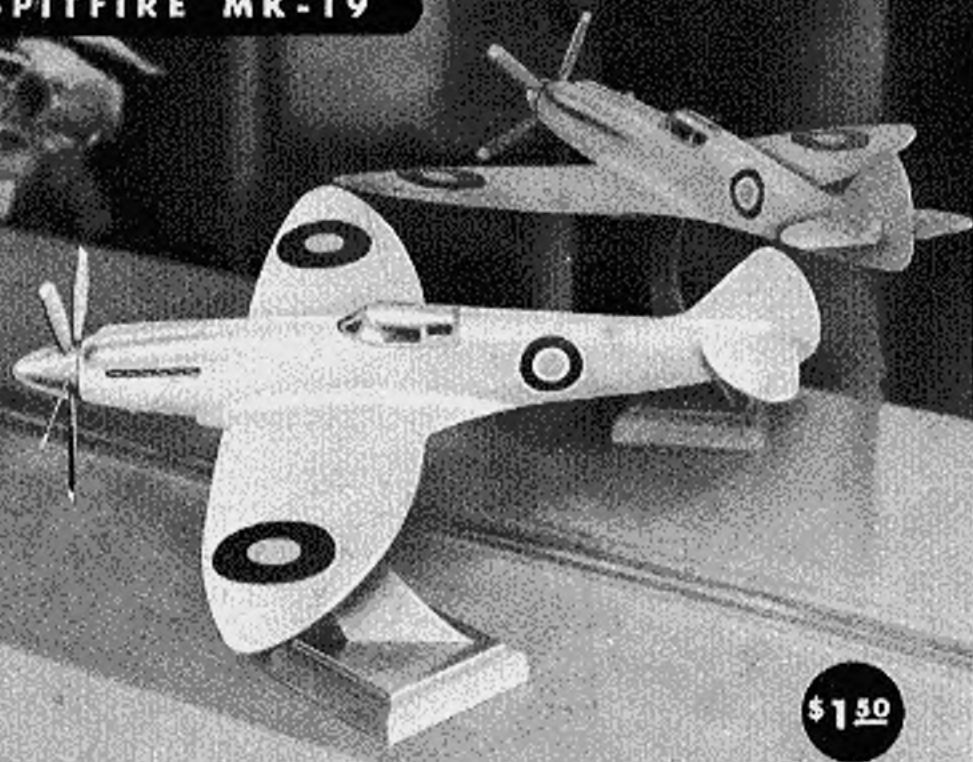

\$1.50

F-86 SABRE JET



\$2.00

MIG-15

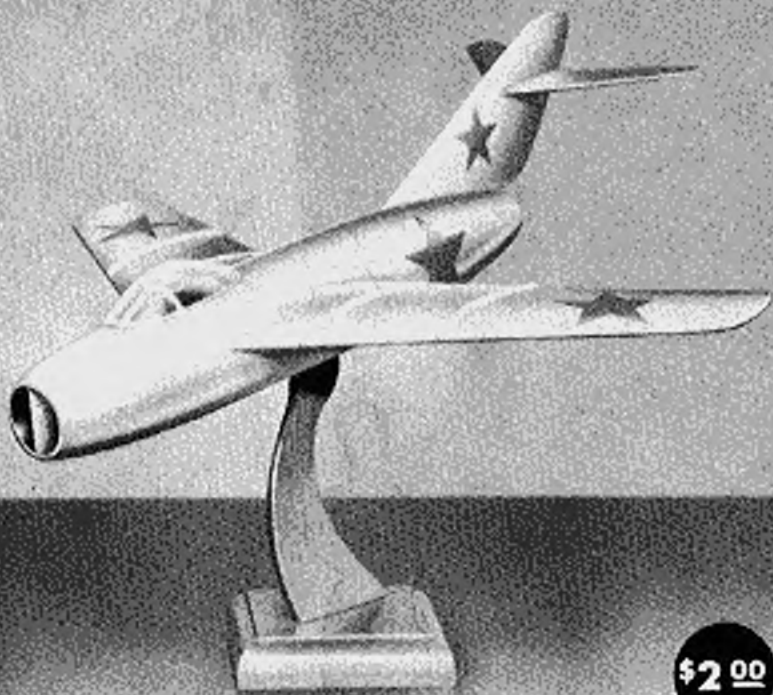

\$2.00

FOR YOUR DISPLAY COLLECTION

You're gonna want all 3...

OF THESE OUTSTANDING NEW AUTHENTIC SCALE MODEL KITS



ALL PARTS SHAPED AND READY FOR ASSEMBLING Testor certainly set a new high standard of quality with the development of this outstanding series of authentic scale model airplane kits! History-makers from the headlines of World War II and Korea, they are masterpieces of detail and design... impressively realistic in appearance... wonderfully easy to build because all parts are shaped and ready for assembling. You will want all three for your display collection, because they make an impressive grouping that will delight your friends and give you new pride of craftsmanship! See your dealer now...

Model	Wing Span	Overall Length
Spitfire.....	17-1/2"	16"
F-86 Sabre Jet.....	17"	19"
MIG-15.....	15-3/4"	16-1/4"

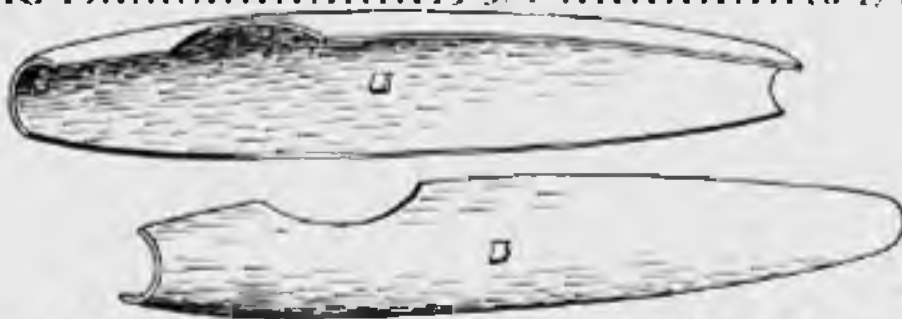

MOLDED Balsa PARTS

Fuselage half-sections and wing half-sections are actually molded into shape! This production process is an important new Testor development that simplifies and speeds construction... adds realism to appearance... makes possible a more perfect finish on your model.

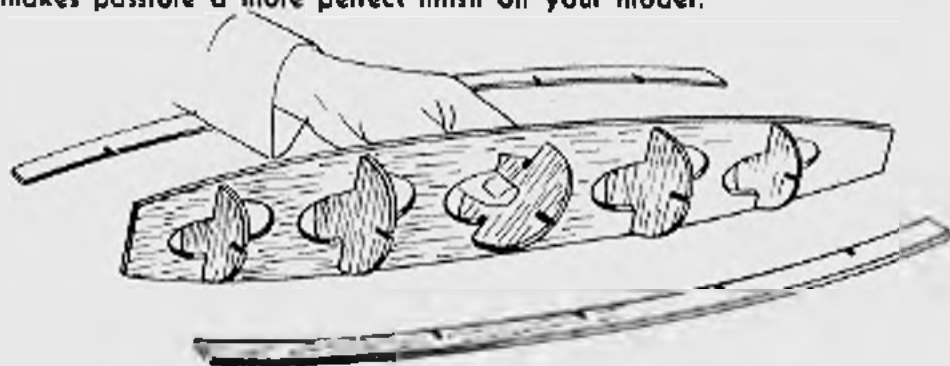

KEY-LOK ASSEMBLY

Note how formers fit securely into place in the keel section with the simple slot-slide action of a key turning in a lock. This exclusive construction technique (patents pending) insures positive location and correct alignment of parts... gives your model greater strength... saves you building time and work.



# MODEL AIRPLANE NEWS

Serving Aviation 23 Years

OCTOBER, 1951

VOL. XLV - NO. 4

## CONTENTS

### CONSTRUCTION

Ringmaster .....	24
Gee Bee .....	32

### NEWS

Scrap Box .....	1
Planes in the News .....	15
Sweden Wins the Wakefield .....	26
AMA News .....	30

### FEATURES

1951 Nationals .....	12
Airways at the Nationals .....	16
Fokker E-1 Masterplan .....	21
We Test the Senior .....	22
Engine Review .....	34
Pen Pals .....	50

### ARTICLES

Can You Really Fly .....	9
Here Come the Jets .....	18
World War I, Fokker E-1 .....	20

JAY P. CLEVELAND, President and Publisher  
WILLIAM WINTER, Editor  
WITTICH HOLLOWAY, Art Director

Contributing Editors: Robert C. Hare, Jim Sattig,  
Joseph Niets

Executive and Editorial Offices  
551 Fifth Avenue, New York 17, N. Y.

Advertising Manager, N. E. Slane, 551 5th Ave.,  
New York 17, West Coast Adv. Mgr., Justin Hannon,  
4628 Cranshaw Blvd., Los Angeles 43, Calif.

Published monthly by Air Age, Inc., 1140 East West High-  
way, Silver Spring, Maryland. Editorial and Advertising  
offices: 551 Fifth Ave., New York 17, N. Y. Jay P. Clevel-  
and, President and Treasurer; Y. P. Johnson, Vice Pres.;  
G. E. Johnson, Sec. Entered as second class matter Feb.  
1951 at the post office at Silver Spring, Md., under the act  
of March 3, 1879. Additional entry at New York, N. Y.  
Price \$6 per copy in U. S. Subscriptions: Rates - Within  
U. S. 1 yr. \$4.50, 2 yrs. \$8.75, 3 yrs. \$12.00. Outside  
U. S. 1 yr. \$5.50, 2 yrs. \$10.00, 3 yrs. \$15.00.  
All other parts of the world 1 yr. \$11.00,  
2 yrs. \$20.00, 3 yrs. \$29.00. Change of Address - Send to AIRPLANE  
NEWS, Subscription Department, 551 Fifth  
Avenue, New York 17, New York, at least one month before  
the date of the issue with which it is to take effect. Send  
old address with the new, enclosing if possible your ad-  
dress label or copy. The Post Office will not forward  
copies unless you provide extra postage. Duplicate issues  
cannot be sent.

Copyright 1951 by Air Age, Inc.

► Spectators howl approval when the combat event gets under way. Team combat flying is stealing the show in u-control circles. A good ship, sharp timing, plenty of nerve, and cagey maneuvering are the prime requisites in this slam-bang event. Attacks, evasions, and kills are the basic flying fundamentals of this new exciting event.

Plymouth rules allow a streamer 8' long attached to the ship with a 2' string leader. Points are given for attacks and evasions. Remaining lengths of streamers add or subtract points to the flyer's score. The ultimate is a clean kill. A kill is scored when one opponent cuts the streamer off completely. A collision voids the score of the pilot at fault. These are the fundamentals.

Hi Johnson and Hobby Bobby Enright have come up with a novel idea. Pilots wanting to fly combat events would have something to work for even though not at contests. Points would be given under the supervision of any Academy Leader Member. Here's the way it works: In combat sessions one small bomb decal would be given each pilot for a kill or win. Ten bombs would win a silver star award. Ten star awards would win a silver winged ace award. Ten silver winged ace awards would win a gold winged ace award. The golden ace awards would be won after 100 kills or wins. There would be no points given except for the short cut of ribbon or a kill. Flights would be made in pairs and pilots would be matched according to the insignias on the side of their ships. Opponents could easily be chosen this way.

Our good friend Bob Ottoman, the Flat Top man, has been stacking up more hardware with his free-flight jobs. Bob hit the bell with a perfect thirty minute total time at the Portland Stardusters contest. He has applied for a tie of the A.M.A. record held by Butch Corbly of San Diego who made his record with his old reliable Sailplane. Ottoman has designed three classes of Flat Tops—36", 56", and 66", and has been cleaning house with them. Who polishes the hardware, Bob? So far Bob's wins have totaled 12 first, 3 seconds, and 2 thirds for the 1951 season.

The Woonsocket Area Flying Fools Modelers have taken the bull by the horns and are out for their own flying site. Seems these lads are a bit griped about being kicked off local ball parks and other juicy flying sites. The Woonsocket lads are after the elusive buck by organizing a paper drive as well as a bond drive. The boys have a mighty fine punch line—"When there's been plenty of gravy, we've had plenty of members to dip into it. This time only those who help produce it will get a share in it."

This year the Woonsocket Flying Fair is expected to be the biggest yet with prizes of over two thousand dollars. Veterans organizations, civic groups, political figures, merchants, etc., are lining up behind the contest committee to help make Woonsocket model conscious. These lads and their backers are out to get a flying field, and it looks from here like they'll get it. Here's one city that is looking out for welfare of its youth. They are taking a leading part in providing an outlet for the creative instincts and surplus energy of the kids who are hanging around with time on their hands. The town is going all out for the modelers so they in turn are bending all efforts to make the most of it.

This "ball of fire" outfit is now in the process of re-organizing its club to form a corporation of all active members who will constitute a permanent board of trustees for the club property. They will be the real club and will have the final say on all matters of club policy. All others members will be recruited on a yearly basis only, and will be subject to the approval of the governing board. The Manville Youth Center under Bob Shields, wants the club to go over and help set up a program for youth activities, while the Amvets of Woonsocket want to co-ordinate the work of its youth committee with the proposed club program. Necessary facilities will be provided. Everyone is getting on the ball to push the mass youth movement, from senators and congressmen to Woonsocket's own Attorney General of the United States, McGrath. Will you other cities of the good old U. S. please take note!

The club guarantees that it will separate the sheep from the goats. Johnny-come-latelies who try to cash in on all of (Continued on page 4)

# Anyone can **WIN!**

## OVER \$3600.00 IN PRIZES

### 4 DIVISIONS

1. FREE FLIGHT AIRPLANE, Powered by an .045 Engine
2. U-CONTROL AIRPLANE, Powered by an .045 Engine
3. FREE FLIGHT AIRPLANE, Powered by an .065 Engine
4. U-CONTROL AIRPLANE, Powered by an .065 Engine

**\$500.00 CASH FIRST PRIZE**

**\$250.00 CASH SECOND PRIZE**

**\$100.00 CASH THIRD PRIZE**

**OVER 300 ADDITIONAL PRIZES**

**ENTER  
NOW**

Contest opens Sept. 1, 1951 and closes Dec. 15, 1951. Final judging of the All American Flying Models Contest will be made by Model Airplane News Magazine and the educational departments of leading Airlines on a basis of skill and neatness according to the detailed instruction sheet obtainable at your dealers.

... for **FREE** details...

**ALL AMERICAN RULES  
AND DETAILED INSTRUCTIONS  
ASSURES AN EQUAL CHANCE  
for DAD, BROTHER,  
SISTER, NOVICE OR CHAMP**

# ALL AMERICAN

## *Flying Models*

# CONTEST

*Sponsored by  
the World's Six Leading Manufacturers of Model Airplanes, Dope, Cement, Engines, Glow Fuel and Accessories.*

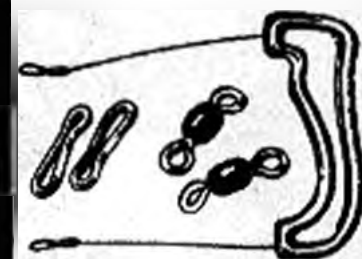
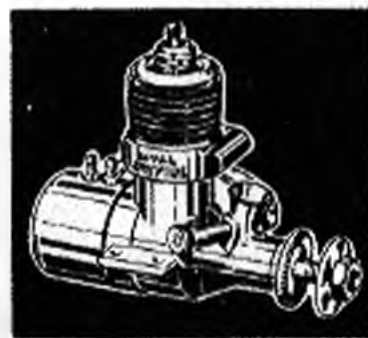

**Berkeley's  
KITS**

Berkeley Model Supplies  
West Hempstead  
Long Island, New York

**410M  
PLASTICATE  
CEMENT**

Stewart Lundahl Co.  
2349 Coldwater Canyon  
No. Hollywood, Calif.

*"Spitfire"*  
**ENGINES**

Mel Anderson Mfg. Co.  
1819 Third Ave.  
Los Angeles 19, Calif.

*"Spitzzy"*  
**NITROMIC  
GLOW FUEL**

Mel Anderson Mfg Co.  
1819 Third Ave.  
Los Angeles 19, Calif.

*Aero  
Gloss*  
**DOPE**

Factra Chemical Co.  
1213 No. Highland Ave.  
Los Angeles 38, Calif.

**PYLON  
BRAND**

**Controls**

Sullivan Products  
214 W. Dauphin St  
Phila 73, Pa.

**See your favorite dealer <sup>\*</sup> TODAY!**

*\*For those living in rural areas, write your dealer or one of the above manufacturers for FREE instructions and entry blanks.*

# PYLON BRAND

# 5" PLASTIC HANDLE

NEW . . . BETTER THAN EVER!

only **85c**



Here is a sensational, new safety handle. No more fussing and fretting tying wire, the PYLON BRAND plastic handle features completely fabricated made up ends of 21 strand lead wire. Stronger, more positive adjustment. Sure-grip, lightweight, fuel resistant. This great new plastic handle is now on your dealers' shelves. Get one to-day and feel the difference!

**FLY SAFELY . . . USE PYLON BRAND CLIPS AND SWIVELS!**

**PLASTIC FUEL TANKS**  
**75c 95c \$1.25**  
*small medium large*

At last . . . here is the only non-corrosive tank model! Plus the exclusive PYLON BRAND "see-into" feature! Visible, adjustable fuel supply. Crush-resistant. Built-in baffle. Now . . . see how your fuel acts inside the tank! We're sure when you see the benefits of a baffle, all your future tanks will have one. Get a PYLON BRAND Plastic Tank to-day!

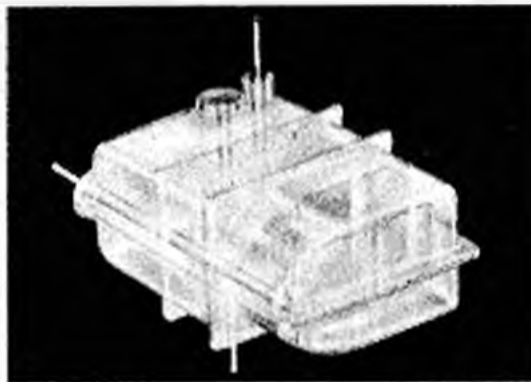

AT YOUR FAVORITE DEALER

*Sullivan Products*



PHILADELPHIA 23, PA.



# Sweeping the Country!

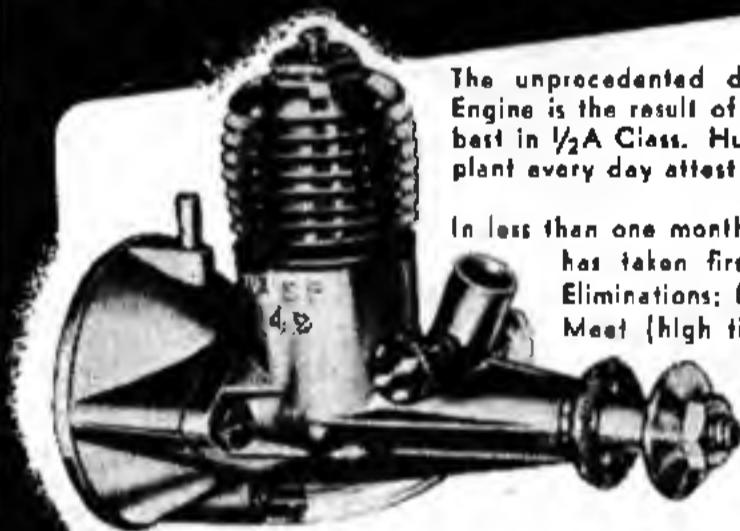

The unprecedented demand for the new Wasp .049 Engine is the result of only one thing . . . it's by far the best in 1/2A Class. Hundreds of letters pouring into our plant every day attest to this fact.

In less than one month since the Wasp's introduction, it has taken first place in the Denver Plymouth Eliminations; first place in the New York Mirror Meet (high time for all classes); first place in the PAA Load Event at the Nationals at Dallas, and two out of the first three places in every 1/2A Free Flight Junior, Senior, and Open Class at the Nationals.

## Wasp.049

DISPLACEMENT

Free Flight Combination . . . . . \$6.75  
U-Control Combination . . . . . 6.50  
Back Cover . . . . . .50

Is it any wonder that even the production is being stepped up every day, we are still not able to keep up with the demand? You can be assured however, that even though our production will be increased, it will not be done by sacrificing the quality or performance of the Wasp .049 Engine.

# ATWOOD MANUFACTURING CO. PICO, CALIF.

## SCRAP BOX

(Continued from page 1)

the work at the last minute will probably have the gate slammed in their faces. Nice going Woonsocket—we sincerely hope you make the rest of the model clubs that are in the doldrums sit up and take notice.

The Lake Erie Gas Model Club is one of the most active clubs in Cleveland due to its initiative and fine cooperation of its thirty-five members. Members, both beginners and experts, endeavor to bring the model hobby to the thousands of youngsters of Cleveland. Air circuses are staged for orphanages, schools, and many other welfare groups. Take a bow, Lew Silvey of the Cleveland Community Fund. We understand that you are the one responsible for making the circuses at the Red Feather Agencies such a success. We've had the opportunity to help stage a few shows for the underprivileged kids here in California and believe us, the youngsters really enjoyed it. You Lake Erie modelers are right on the beam. Carry on and keep those kids happy. We'd like to see more clubs get in the act and fly exhibition for the kids who have never seen flying models.

The big engine and glo-plug scare, shortages, etc., due to the Korean war, brought up an interesting topic—the Diesel engine. Our good friend, Ted Buxton of England, tells us that the British modelers have been making tests of our .099 and AA engines. Ted tells us that over there the boys are convinced, both from B.H.P. curves and experience, that the glo jobs are not as powerful as the diesels of equivalent size. In comparison with one of our outstanding .049 jobs swinging a 5" / 3" prop that was supplied, one better Diesel (.031) turns a 7" / 4" the same speed. The British modelers go to meets via the bus and subway and the smaller ships of around 150 sq. inches are the popular ones.

The famed English Bowden trophy, formerly awarded for Precision Flight, is now going to be given for the payload event. The "PAA Load" is in the form of one eight-ounce pilot. Pan-American Airways has offered to present souvenir trophies to the winners of the first official payload event to be held in England. We'll be very interested in the performance of the powerful AA diesels in this event. Looks like their power should pay off here.

Eighteen thousand spectators watched 75 contestants fight a 45 knot wind to participate in the First Shepard Air Force Model Airplane Meet in Texas. Contestants came from other bases to compete in the minor hurricane. Lt. Harry G. Vogler Jr. C.D'd the meet. Pat Massey and Babe Hall of Pampa teamed up to walk off with the high point trophy for the meet. Their

Mac 49 job turned in an official speed of 129.48 m.p.h.

Endurance flying is now giving a flock of modelers the "urge." Some rules have been set up. The main idea of the event is to see how long the flyer can keep his ship in the air without refueling. Test flights have been made with many different types of ships and engines. Naturally, to get top time a modeler should build a ship that will carry a phenomenal gas load and have an engine with low fuel consumption and plenty of power. Bury a couple of quarts of fuel in the fuselage, wing, or any other place that will work and get the ship into the air. Have a couple of strong armed helpers to get on the handle when the old back muscles start to scream. There's no ruling on engine size or ship design, as long as it's u-control. If you think this event is a cinch, get the drawing board out and start in. We'd like to get some results of your efforts if you take a whirl at this type of flying. What a testing ground for engines, glo-plugs, fuel, pilots, etc.

Bernice Jaynes of San Francisco racked up a nice endurance flight of 1 hour 25 minutes with her Anderson Spitfire 60 job. O & R glo fuel was used to fly the 821 laps at an average speed of 48 m.p.h. Take-off weight 7 lbs. 13 oz.; weight at end of flight 4 lbs. 4 oz. Mileage 117 per gallon; total distance flown 88.4 miles; amount of fuel used

2-1/3 quarts.

Wouldn't be surprised to see everyone going to work on one of these jobs. Let's hear from you.

A modeler from Tulsa, Oklahoma, would like to make a few statements about flyers entering as a team in model meets. This opinion is evidently shared by many so we'll quote: "The 'team type' contestant is recognized under the AMA rules but the rule is not clear on just who should build the model or models that are being flown. It states that all team members must actually engage in the construction but this could be loosely construed as meaning the glueing in of a couple of ribs or putting on a coat of dope. By teaming up and loosely complying with the rules, it allows up to three contestants to combine their models and compete against the lone modeler. You can see this would be very advantageous on a high point award basis—twice as many planes could be constructed for a multitude of events with only one fellow on the team required to fly the models. In u-control this 'flying rule' could be construed to apply to either team member. If the model is hand launched this becomes as much of the flying procedure as the fellow in the middle of the circle actually controlling the model." This modeler, as do many others, feels that the team entry should be (Continued on page 36)

**A DELUXE A.H.C. BARGAIN COMBO**

**ROYAL SPITFIRE .065**  
Most Powerful 1/2A engine

**CURTISS P40F**  
(By Monarch)

**PLUS** 20" wingspan 'Spittin' Image' control-line model. Extra deluxe kit. PERFECTLY and COMPLETELY PREFABRICATED. A beautiful model you will be proud to fly—and a cinch to build in only one evening.

**PLUS** EVERY accessory to build and fly except dope, fuel and battery. INCLUDED are matched propeller, tank and fuel line, glo plug, connecting clip and wire, wrench, motor mounts, mounting bolts and nuts, flying wire and reel, control handle, motor cover, identification tags. Presto engine starter, all hardware, bellcrank, elevator horn, hinges, sandpaper, cement, rubber wheels, decals, lead-out and pushrod wire, formed landing gear, engine instructions, full-size plane plans and instructions, log book, speed indicator, PLUS Glo Engine Handbook, giant book on Control-liners, PLUS membership in Modelcrafters of America, postage, packing, insurance and 64 page 2-color hobby catalog.

**BEAT THIS COMBO PRICE IF YOU CAN**  
A \$15.00 VALUE **FOR ONLY \$9.95**

**AMERICA'S HOBBY CENTER**

**EVERYTHING** in this magazine can be ordered from A.H.C.

**N. Y. CITY MODELERS**

largest retail stock in N. Y. — 4-story building to serve you. Near all subway. DROP IN FOR YOUR MODELING NEEDS. Bernard & Winston, modeling author and expert, always here to help you with your problems. Complete stock of engine parts and service.

- WHAT OTHER HOBBY STORE GIVES YOU:**
- 1. FREE one year subscriptions to Model Airplane News, Air Trails and Flying Models to our regular customers.
  - 2. 14-Day Money Back guarantee on unused purchases.
  - 3. Unused purchases exchangeable within 14 days.
  - 4. No postage or packing charges — we insure safe delivery.
  - 5. 24 Hour service. Mail addresses in Chicago, Denver, New Orleans and San Francisco which will reroute your orders to our N. Y. office for prompt shipment.
  - 6. Most complete model stock in America — gas, rubber, solid, etc., etc. If it's advertised, we can usually supply it.
  - 7. Competent understanding of your modeling problems.
  - 8. No "minimum" orders. Any order is welcome.
  - 9. FREE gas meters, 50 ITEMS WORTH OVER \$7.00 AT NO EXTRA COST.
  - 10. FREE rubber wheels, knife, etc., etc., with every gas plane selling for over \$1.50. 12 ITEMS WORTH \$3.50 AT NO EXTRA COST.
  - 11. FREE membership in "Modelcrafters of America", the club that keeps you up to date on gas modeling and SAVES YOU MONEY ON YOUR PURCHASES.
  - 12. FREE illustrated giant 2-color 64 page catalog with every order.

**AHC does!!**

**HOW TO ORDER**  
Send remittance in full (we prepay packing and insure) or send \$1 and we ship collect C.O.D. same day for balance. Address your order to us at your nearest branch office.

*America's Hobby Center INC.*  
DEPT. MC-101

Please RUSH me the following:

Name.....

Street Address..... Amount Enclosed.....

City..... Zone..... State.....

Page	Quantity	Name & Description of Items	Cost Each	Total
➔	ONE ONE ONE	ENGINE TROUBLE TRACER & AID MANUAL SPEED INDICATOR CHARTS FLIGHT LOG BOOK	FREE	with each order
				Total

24 HOUR SERVICE AT ALL TIMES

**FREE** Handy WORK-BENCH EDITIONS of the \$1.00 "Control-Liners — How to Build and Fly Them" or "Glo Engine Handbook" for only 25c each, if you use this order blank.





# Complete FLYING OUTFITS

WORTH TWICE OUR COMBINATION PRICE!

## WE WILL SUPPLY

A complete flying outfit with your own choice of any advertised engine or plane—and save you money. Just order from us or write for price.

IF IT'S ADVERTISED, WE HAVE IT

**IT ISN'T OFTEN** that you get the chance to buy, at less than half price, a U-Control Plane, Engine and All-Accessory Outfit with your own choice of a well-known **FACTORY ASSEMBLED** ignition or gls engine. Everything carries the famous America's Hobby Center as well as the manufacturer's guarantee.

Even if you are a beginner, you won't have trouble building and flying any of these flying outfits, full-size plans of any easy-to-build and fly plane, every accessory you will need, complete instructions, etc., etc. If you are an old-timer at building and flying model planes, we don't have to tell you what these bargain outfits are really worth.

Thousands of these complete units have already been sold. They have met with enthusiastic reception because they represent a value unheard of before in the modeling field. The price is so low that we cannot sell to dealers. You really save from \$10 to \$12 by buying the complete, packaged unit—everything is engineered by experts for a perfect flying combination.

**YOUR OWN CHOICE OF ENGINE, PLANE, PLUS ALL ACCESSORIES, INCLUDING:** Correct size finished propeller • 3-way plug wrench • Presto Engine starter with handle and cord • Speed indicator tables • Log Book • Motor cover • Spark or gls plug with gasket • Complete engine instructions • 24 page Gas Engine Theory Manual • Engine adjustment chart • Metal fuel tank and gas line • Metal Battery box • Wilson Quality Coil • 12" Hi-tension lead wire and end clips • 18" insulated ignition wire • Ignition slide switch • Coil holder and mount • Everlast condenser • SAE #70 Oil • 4 Ignition wiring lugs • Spark plug gauge set • 2 plane identification tags • 72 insulators • **GIANT** book on Control-Liners, How to build and fly them • Cement • Sandpaper • "Pro" all-metal knife and blade • Metal ballcrank with ball, nut and washer • Elevator horn • Elevator hinges • Lead-in wire • Push-rod wire • U-Control handle • 100 ft U-Control stainless steel wire reel • Membership in Modelers of America • 64 pg 2-color catalog • Postage • Packing • Insurance. Ignition parts not needed with gls-engine not included.

## YOU WON'T GET OTHER BARGAINS LIKE THESE!



**BUZZ**  
Ignition  
or gls  
**\$8.50**



**JUDD**  
Ignition  
or gls

**RAM**  
Ignition  
or gls

**YOUR CHOICE \$10.00**





**McCoy 19**  
GLO

**THOR**  
Ignition

**MOHAWK**  
CHIEF

**YOUR CHOICE \$12.50**



**McCoy 19 and 29**  
GLO

**ORISSON**  
W-22  
GLO

**YOUR CHOICE \$13.50**



**ORISSON 19**  
Ignition  
or gls

**PHANTOM**  
Ignition  
or gls

**YOUR CHOICE \$15.00**



TRAIL BLAZER Model Plane with curved lower fuselage-half, fully formed aluminum upper half. Balsa sheet wing, no tissue used. Balsa tail surfaces, plywood engine mount. Schematic drawings with step-by-step plans. Rubber wheels, detail paint schemes. 24" wingspan.

**PLUS ALL ACCESSORIES LISTED ABOVE**

### NEW .099 UNITS

Includes all 3 items

For ease of assembly, for trouble-free operation and for real effortless U-Control flying, these units are the answer to the modeler's dream. Even the beginner will have no trouble in assembling the outfit in one evening and be completely ready to fly the next morning.

**1 You get your choice of**



**2 PLUS** Your choice of 2 completely prefabricated kits



**3 Plus all accessories**

**COST ONLY** McCoy 9 GLO Outfit \$10.95  
O.K. Cub .099 Outfit \$ 9.95

### AA FLYING OUTFITS

These are the new pint-size gls engines that are so tiny (1 1/2 to 1 3/4 ounces) but develop plenty of power for free-flight or U-control flying.

Your own choice



Plus your choice of planes! All planes prefabricated, easy to build and fly



Plus all accessories

### 5 AGES OUTFIT

The biggest bargain we have ever offered. Over \$10.00 of merchandise for only \$5.85.

**1 YOUR CHOICE OF**



**2 PLUS** your choice of 4 prefabricated Scientific 22" span u-control planes.



**3 PLUS ALL ACCESSORIES**

**COST ONLY** With O.K. Cub \$9.95  
With Spitzy \$5.85

BIGGEST BARGAIN OF THE YEAR

### AERONITE \$9.95

A really beautiful red plastic job 17" wingspan with Baby Spitzy engine, prop spinner, tank, etc. already installed. Shock-absorbing spring steel landing gear, no Walter U-control for precision and silent flying. Plastic control handle, nylon control cord.



### A. J. FIREBIRD \$7.50

Beautifully finished and painted, even fuel-proofed 18" span. Includes new "stem-molten" propeller and engine.



### READY-TO-FLY OUTFITS

All you do is take the plane out of the box, fill the tank, and FLY. You don't have the fun of building—the fun's in the flying. Just nothing to build. And to fly, all you'll need extra is fuel and battery. All U-control.

### BUSTER \$7.95

Scale model of Whinnex Special. 12 1/2" span. K & B Trop Jr. engine already installed.

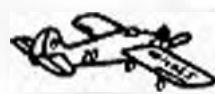

### DOUGLAS NAVY SKYRAIDER \$9.95

All plastic model including K & B Trop Jr. engine. Landing gear with aluminum wheels, deck, tank, spinner, etc., etc. Includes nut and bolts for minor assembly.



### YANK \$5.95

23" span championship model finished in two colors and fuel-proofed. Equipped with O.K. .019 engine and all accessories.



**SOLDIERS!  
SAILORS!  
MARINES!**

Orders placed through us get special attention. We understand your problems and take special care of your orders. Or send for our **SPECIAL SERVICES DATA**



**\$7.95**

**COMPLETE RACE CAR COMBINATION OUTFIT**

With 1/20 scale "AAA" gls engine, complete with duct drive (P.O. D.A. 604) engine (P.O. 604) and needed accessories. Plus motor when you open the package. You can race the car in any smooth surface. Even your own backyard or cellar. Speeds over 60 miles per hour. **COMPLETE** except for fuel and battery car. Price \$5.95.

**How To Order** Send remittance in full less postage and insurance

- Dept. MC 101 156 West 22nd St., New York 11, New York
- Dept. MC 101 55 E. Washington Street, Chicago 2, Illinois
- Dept. MC 101 Rm. 230, 742 Market St., San Francisco 2, California
- Dept. MC 101 Rm. 308, 427 Carondelet St., New Orleans, La.
- Dept. MC 101 Gas & Electric Bldg., Denver 2, Colorado

or send \$1 and we ship collect C. O. D. same day for balance. Address your order to us at your nearest branch office.

*America's Hobby Center* INC

A GENERATION OF FAIR DEALING GUARANTEES YOUR SATISFACTION



# for HIGHEST POWER! for LOWEST PRICE!

More for your money when you buy "OK"! Every "OK" engine is block-tested and guaranteed — every one gives quick, sure starting . . . longer, more powerful operation . . . more hours in the air. So for championship performance, make your next engine an "OK"!



### Most Powerful in its Class! "OK" CUB .074

Exclusive patented port design provides greater turbulence, more effective scavenging, highest power/weight ratio for a displacement of only .074. Bore .479 Stroke .415, Weight 1 3/8 oz. \$5.95

### SAVE MONEY on this easy assembly "OK" POWER KIT—a \$6.15 value

Kit Contains: .049 Cub, combination engine mount and fuel tank, neoprene tubing, starting pulley, propeller. Easily assembled in 15 minutes. You save \$1.20 \$4.95



## OVER ONE-QUARTER MILLION "OK" CUBS FLOWN AND RACED



### .049 CUB

Outstanding Half-A for free flight and indoor flying \$5.25



### .039 CUB

This is the Real Engine for your first power model . . . easy to install . . . a snap to start \$4.95



### .099 CUB

Outstanding for its rugged powerful Class "A" performance \$6.95

### "OK" CUB ACCESSORIES

Flywheel for .039, .049, and .074 Cubs . . . 60c  
Propeller Spinner . . . fits all Cubs . . . 15c  
Starting Pulley . . . fits all Cubs . . . 25c

Engine Mount and Tank . . . fits .049 and .074 Cubs 50c  
Mounting Bracket . . . .099 Cub only . . . . 30c



### "OK" CUB COMBINATION PACKAGES

.049 only \$5.75  
.074—\$6.75 .099—\$7.75  
Contains your displacement choice "OK" Cub engine, plus propeller, wedge type fuel tank and neoprene tubing.



### 1950 Class "A" Leader "OK" BANTAM

A better than ever edition of the famed record breaker. Weight 3 1/4 oz. with range of 2,500 to 11,500 rpm. With glow plug, less tank \$9.95

### 1950 Class "B" Leader "OK" HOTHEAD

New features include ebanized cylinder, gold anodized high compression cylinder head. Complete with glow plug and tank. \$10.95



### 1950 Class "B" Bargain "OK" MOHAWK CHIEF

A high quality precision engine in the low price field. Superbly engineered . . . block tested with full 60-day guarantee. Complete with glow plug and tank \$9.95

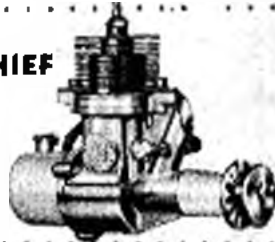

### 1950 Class "D" Leader "OK" SUPER 60

With new ebanized cylinder, gold anodized cylinder head, aluminum crankcase, large ball bearing. Complete with glow plug and tank \$11.95



### IGNITIONLESS "OK" CO<sub>2</sub>

A cinch to mount, ready to run without plug, coil, condenser, battery, booster, wiring, timer or needle valve to worry about. Runs on compressed gas \$5.95



### "OK" SUPER 60 MARINE

Basically the same as the Super 60 . . . with flywheel for use in racing boats and cars. Complete with glow plug and tank. \$14.95

### MIGHTY "OK" TWIN

For large models and radio controlled ships. Weighs 23 oz. with tank. Up to 6,000 rpm complete with spark plugs and tank \$55.00



### Dynamite in Every Drop! "OK" GLOW FUEL

Methanol base, heavily fortified with nitrates. Ideal for break-in . . . operates over a wide range of climatic conditions 85c pint



### "OK" COILS

Fast spark, low battery drain — for "A" to "D" Class. Complete with lead. \$1.50

### TWIN COILS

For all makes of two cylinder engines—with leads and matched condenser. \$4.00



### SENSATIONAL "OK" GLOW PLUGS

Proved to be the best all 'round plug — makes engine start fast—accelerate easily —operate over wide range of speeds. Short or long . . . 59c

# HERKIMER

## TOOL & MODELWORKS INC.

210 Harter St. Herkimer, N. Y.

**SEE YOUR DEALER TODAY**  
or write us direct:  
Engines and complete parts service at your dealer's. See him today, or write direct for catalog to:

can  
you  
really  
FLY?

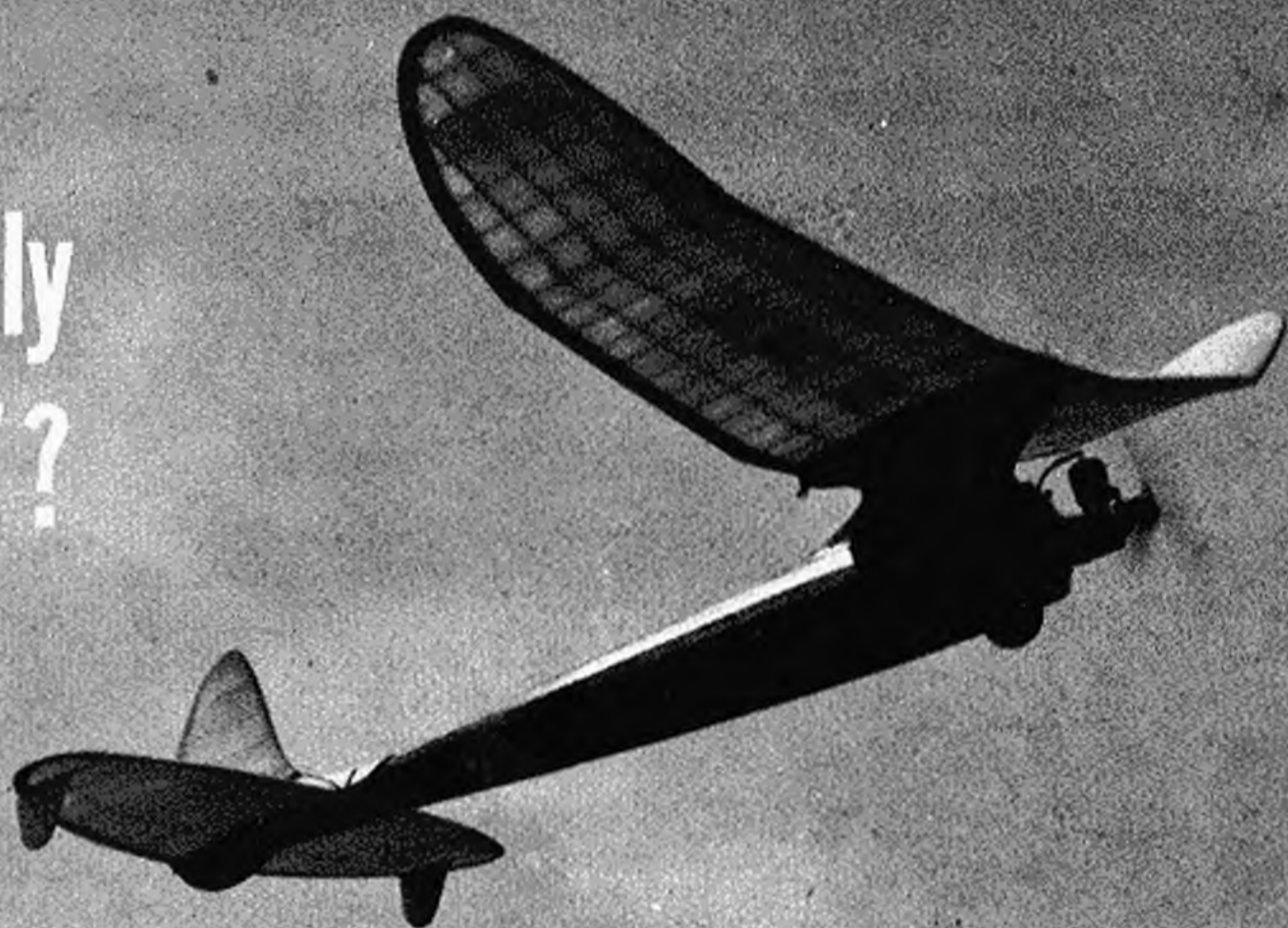

by DICK EALY

► "There is more than one way to skin a cat" is an old saying that can be applied to model aircraft also, as there is more than one way to fly any model. An expert knows these various "set-ups," but since this article is primarily for the average Joe, we present one "set-up" for each type ship to avoid confusion and disaster to the newcomer.

We have asked well-known builders of each type to release his favorite method of flying for readers of MODEL AIRPLANE NEWS, and wish to express our thanks for their "secret weapons." Study the three-view diagram that interests you and read the corresponding text carefully.

**FREE-FLIGHT GAS:** Bob Holland won the 1948 National Championship at Olathe, Kansas. Those who know Bob well and have seen his craftsmanship can well understand why he deserves this highest honor. This is the "set-up" used by Bob in flying his gas jobs. It is very simple and novices will find it pays off with beautiful flights.

The airfoil is similar to the N.A.C.A. 4412 but is reduced to ten percent thickness. It is set at three degrees incidence. The horizontal tail is a flat-bottomed airfoil of seven percent thickness and mounted at two de-

degrees incidence. The vertical rudder is mounted perfectly straight. The engine is mounted with no downthrust but has five degrees left to make the model turn in left circles under power. With this set-up the left wingtip panel must be warped down (wash-in) on the trailing edge about two or three degrees to prevent the ship from spiraling in under power. The center of gravity should be 75 degrees back from the leading edge.

Early morning or late evening when the air is calm is best for testing. Hand glide the model first until the ship makes a long flat glide, circling to the left. Drag of the warped left wing will cause this left circle. Next set engine timer to run five seconds. This is very important as you do not want the ship to come down under power if it is not perfectly adjusted. This short time will enable the ship to recover and glide down. Start engine and run up to top R.P.M., then slow it down by making carburetor mixture a little rich. Hand launch the ship into the wind—if there is any at the time. The model should climb steeply and in left circles, then go into a flat left glide when the engine stops. If ship shows tight banks without climbing, this can be remedied by lessening the left-thrust to two or three degrees. With each following flight the engine run may be increased by two or three seconds at a time, not more. Also the motor may be leaned out a little more with each flight until you reach maximum performance.

**OUTDOOR RUBBER:** Andrew Petersen, 1949 U. S. Wakefield team member, uses this adjustment for the stick model shown. It may be applied to all types and sizes of rubber models. He uses a Ritz airfoil with McBride B-7 camber set at four degrees incidence. The horizontal tail surface has the same airfoil section set at zero incidence. The prop is a 15 in. dia., free-wheeling type, powered with 22 strands of 3/16" (T56) rubber on this 190 sq. in. model. The thrust line has two degrees down and one degree right. The rudder is offset to the right eight degrees in order to offset torque. The C.G. is 66 per cent of the chord back from the leading edge.

Pick a time when there is calm air to test fly your model. Hand glide the ship first and adjust the wing fore or aft to obtain the proper balance. It should glide flat, circle to the right before any power is applied. Wind the model by hand for about a row of knots and hand launch the ship. It should climb to the right and continue circling to the right after power is exhausted. Now the ship can be fully wound by stretching the rubber three times the normal length, winding as you come in toward the ship. Again hand launch the ship in a climbing angle.

The model under power climbs in right circles and continues in the same direction throughout the glide. If the power circle becomes too light, the climb is destroyed and the model assumes a normal nose-up attitude only after the initial power burst is exhausted. This condition is remedied by reducing the amount of right-thrust.

**INDOOR RUBBER:** Frank Cummings won the 1947 National Championship held at Minneapolis. His indoor ships played a big part in winning and a little later set the World Indoor Stick record of 29 min. 23.5 sec. at the Santa Ana blimp hangar. Frank probably has more flights over 25 min. than any other builder. His craftsmanship is unexcelled as shown in the ultra light weight of his ship. The set-up shown here is for his class C indoor record stick model, but the same applies to cabin models.

Frank uses a relatively thin airfoil which is only 5-1/16" thick on a 5-1/2" chord. Maximum camber is 40 percent back from the leading edge. The wing has two and one-half degrees incidence. The horizontal tail uses the same section mounted at zero degrees. The vertical rudder has 13 degrees left turn. There is no side or down thrust in the propeller. Frank compensates torque by offsetting wing 5/16" on the left wing. To find wing position, assemble completed motor stick with prop, rubber, tail. Balance this assembly and mark lightly with a pencil. Glue in paper wing mounting tubes so that 40 percent mark falls on the C.G. pencil mark. The center wing panel should have 1/16" wash-in at the dihedral break (trailing edge warped down). The left wingtip should have slightly more wash-in.

Careless handling is more responsible for breaking indoor ships, so be very careful (Continued on page 42)



Low Mahieu, holder of both free flight and speed records, with his Torp-powered Zeka. Ship widely built and flown during the 1950-51 seasons.

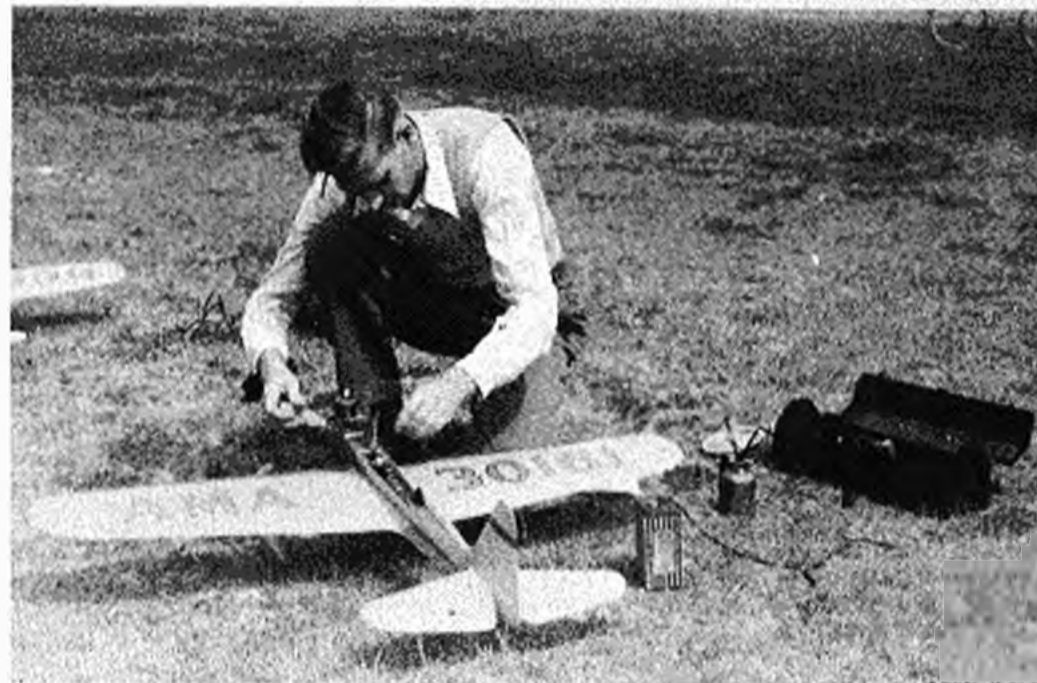

"Madman" Yates, who put the stunt in modern stunting checks his ignition, Orwick-powered Madman. Isn't afraid to put on a swell paint job!

Off we go! In any of the control line events a good helper is an asset. Do you look for racks, snags that may catch those lines during take-off?



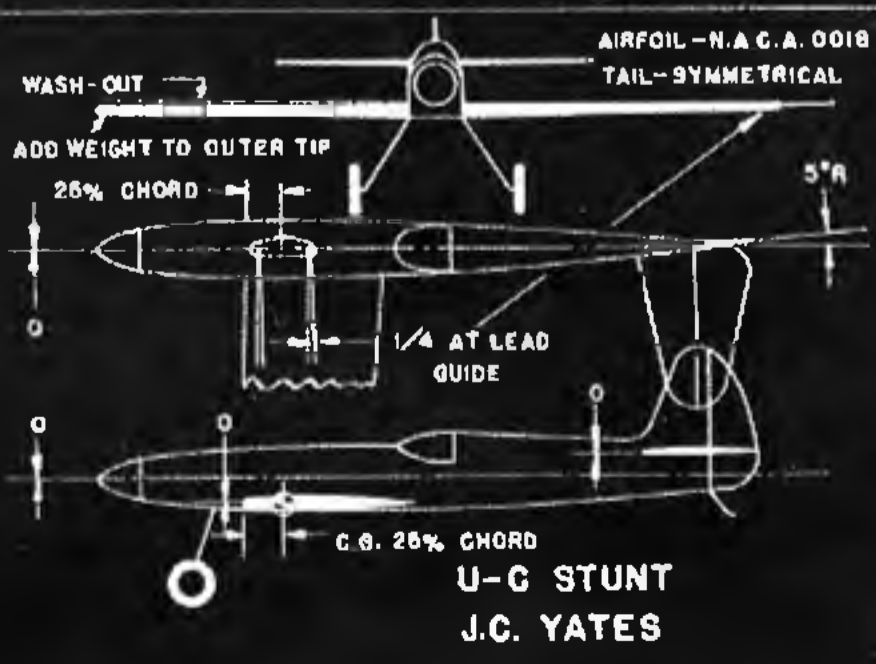
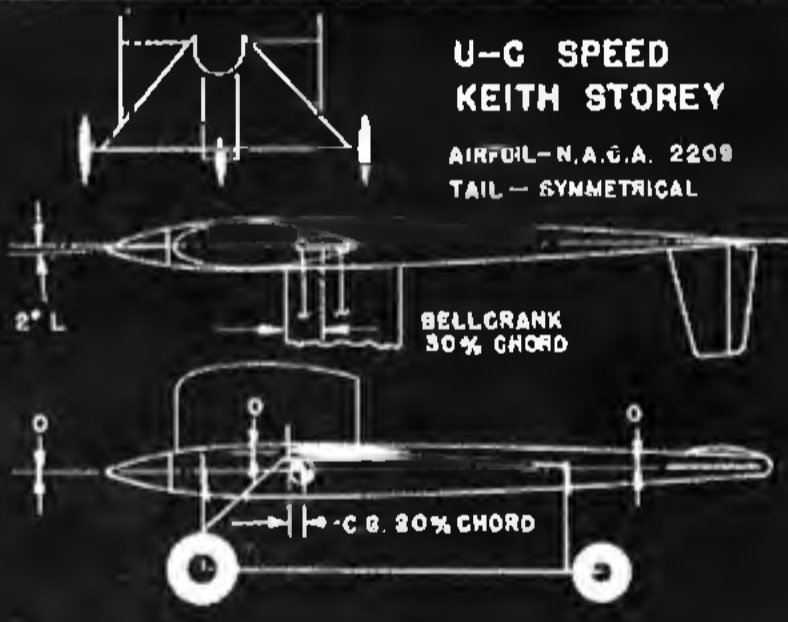
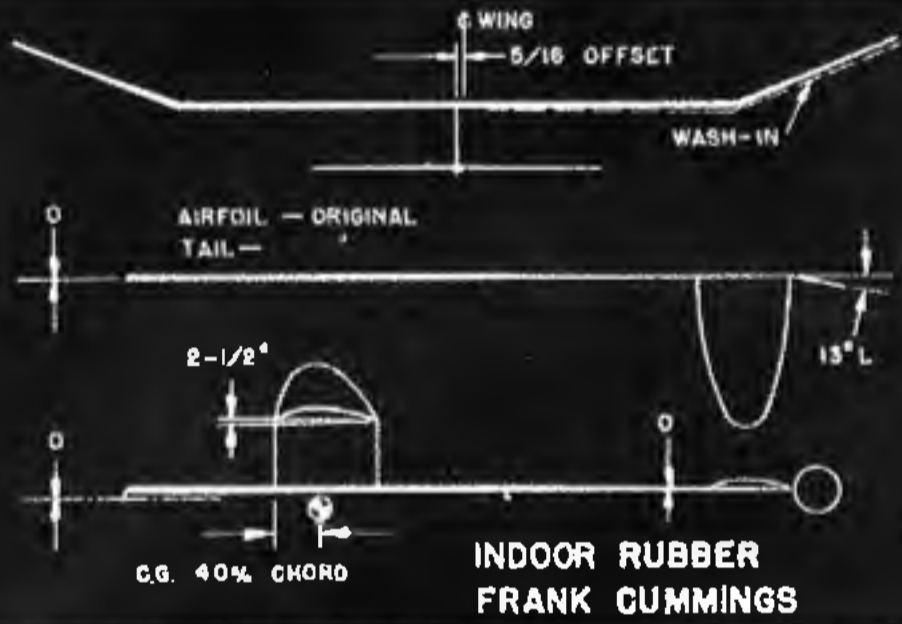
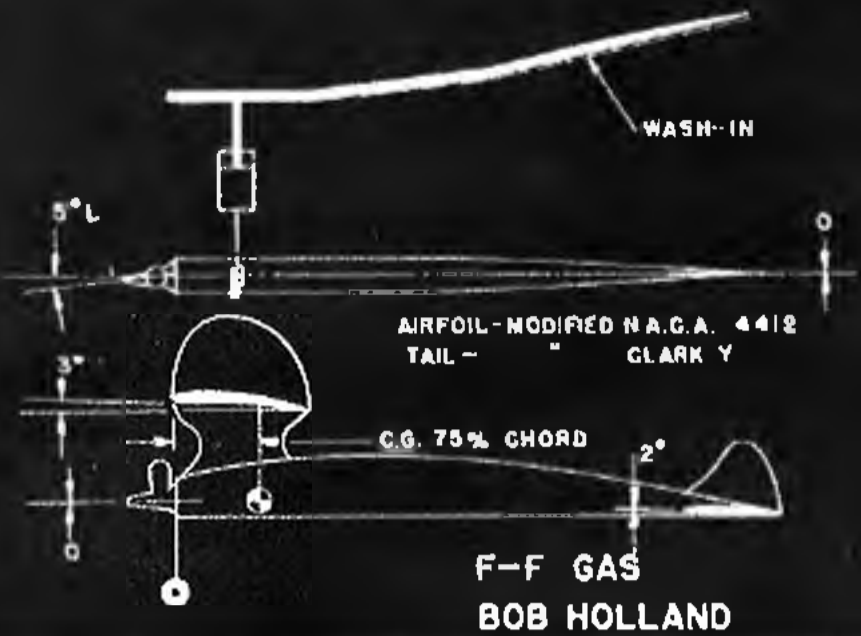

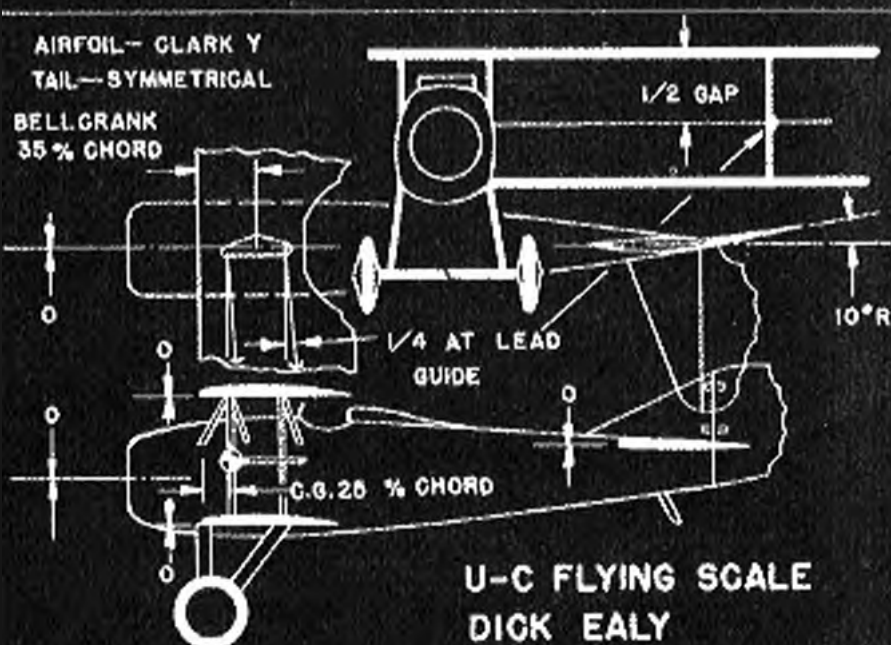
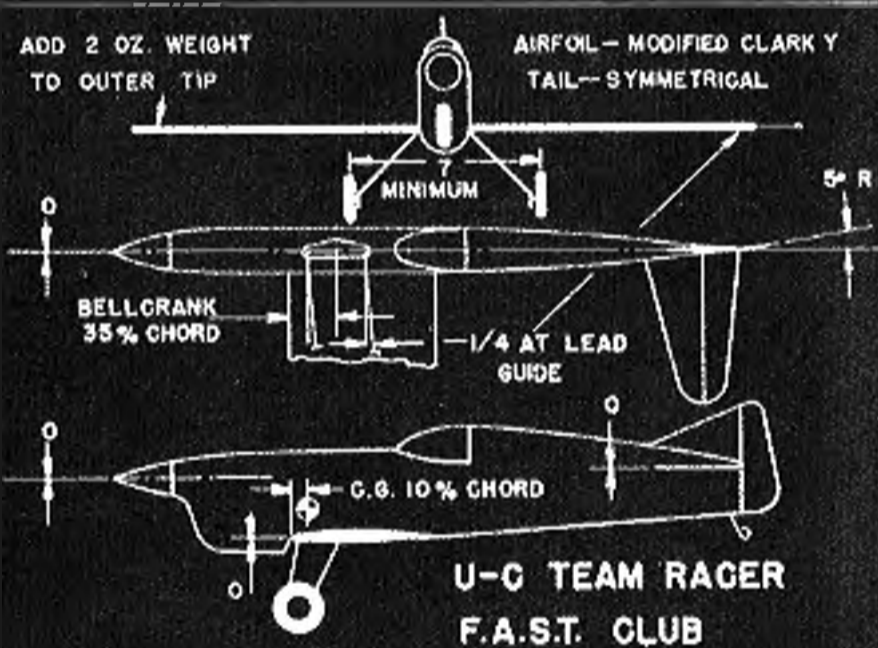
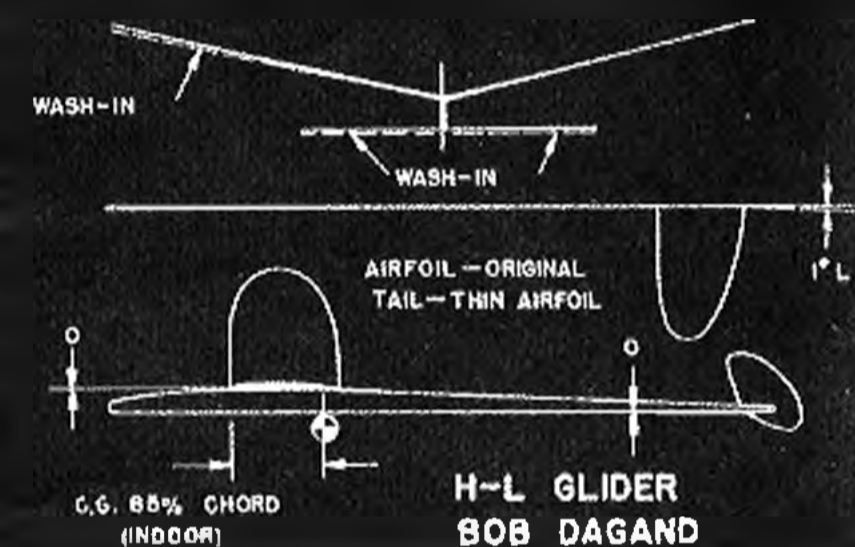
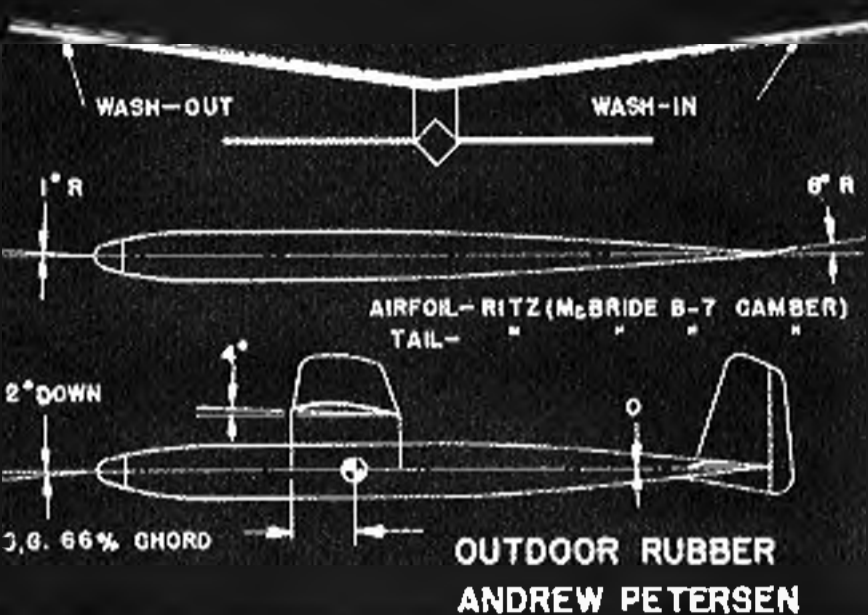

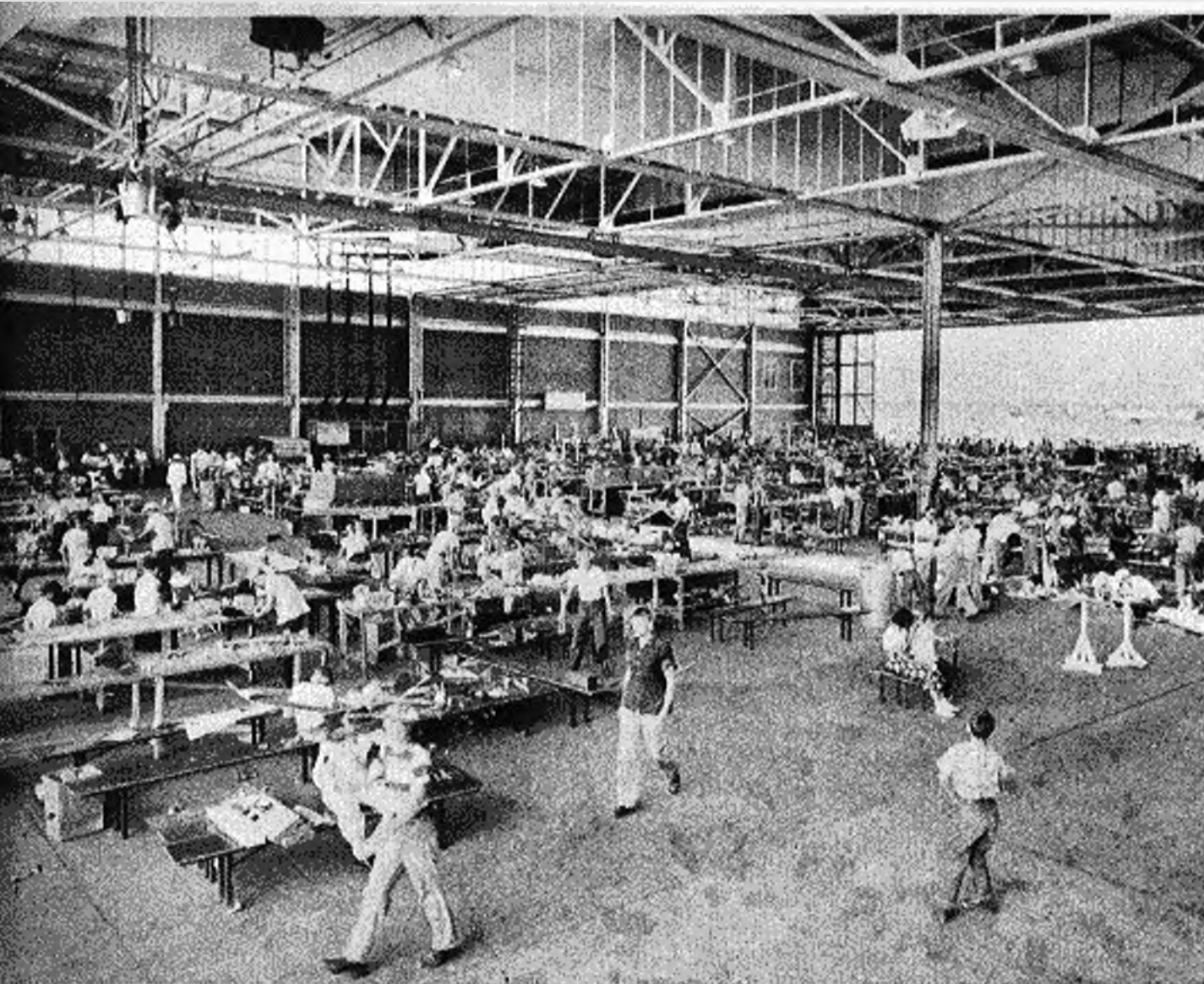

Hangar repair shop at a relatively quiet moment. Navy obligingly set up the work benches.

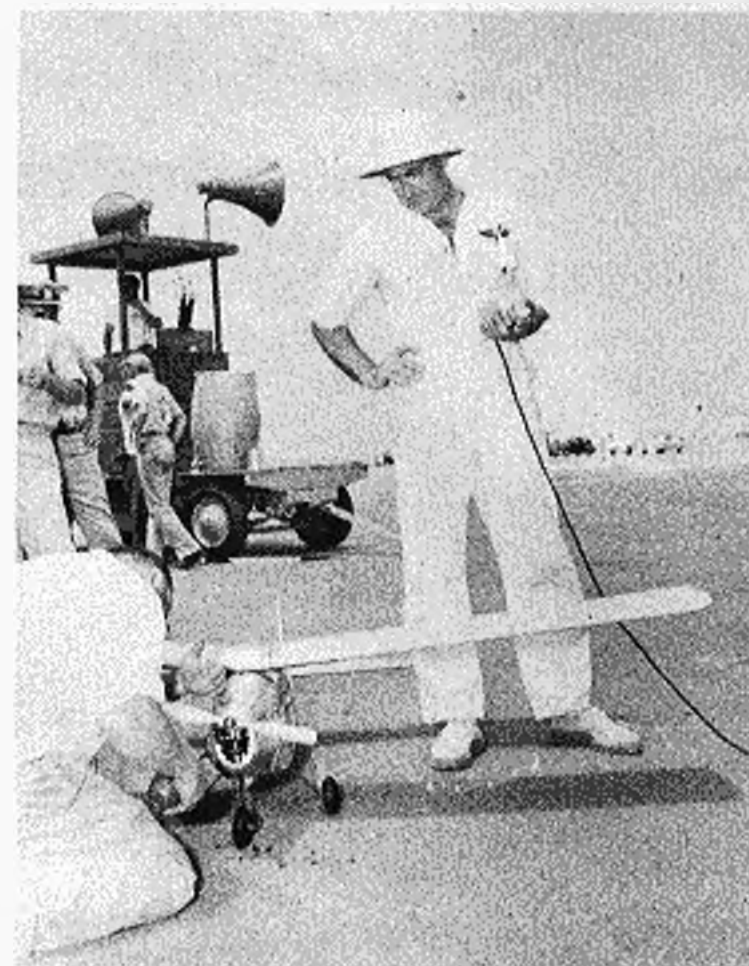

Jim Walker frowns impatiently at his winning rc.

# 20th Nationals 1951

**DALLAS, TEXAS**

From July 24  
thru July 28

## THESE ARE FIRST PLACE WINNERS. NATIONAL CHAMPION

### SPEED

- Class A: Jr.—Tommy Davis, 110.56 mph; Sr.—Robert Katzman, 116.27 mph; Open—Pat Massey and Carl Hall, 114.35 mph.  
 Class B: Jr.—Alfred Davis, 127.29 mph; Sr.—Herbert Davis, 125.78 mph; Open—Anthony Grish, 136.98 mph.  
 Class C: Jr.—Jimmy Price, 121.29 mph; Sr.—Jack Friedland, 137.51 mph; Open—Lee Hill, 136.88 mph.  
 Class D: Jr.—Harry Flegel, 148.88 mph; Sr.—Herbert Davis, 148.76 mph; Open—Pat Massey and Carl Hall, 146.69 mph.

### FREE FLIGHT

- Class A: Jr.—Richard Moore, 16:49.4; Sr.—Robert Gelvin, 22:21.6; Open—Sal Taibi, 27:44.1.  
 Class B: Jr.—Gene Jackman, 15:29; Sr.—James Carpenter, 18:50; Open—Ernie Shaller, 21:41.4.  
 Class C: Jr.—Curtiss Franken, 18:43; Sr.—Don Murray, 22:00; Open—Robert Ottaman, 28:05.4.  
 Half-A: Jr.—Don Tuna, 13:29; Sr.—Jack McComb, 15:07.6; Open—Dick Everett, 22:05.  
 ROW: Jr.—Bill Loflands, 4:11.8; Sr.—R. Edward Mate, 11:27; Open—Dan Lutz, 18:44.4.

### INDOOR

- Stick: Jr.—Earl Hoggard, 10:51.4; Sr.—Paul Simon, 15:36.9; Open—George de la Mater, 21:47.5.  
 Cabin: Jr.—Steve Benovitch, 3:51.6; Sr.—Otto Helthecker, 9:41; Open—George de la Mater, 19:43.3.  
 Hand launched glider: Jr.—Don Tuna, 1:41.9; Sr.—Charles Bushing, 1:55.5.



The old water barrel was everybody's favorite. Right—Towliners waiting their turn to fly.





Tony Grish shows record speed job to MAN editor.

Johnny Clemens, Arthur Godfrey, G. Jackman.

Start 'em young! Bill Teague, and his son Larry.

**IS PAUL SIMON, A SENIOR. OPEN CHAMP IS BOB BIENENSTEIN; JUNIOR IS GENE JACKMAN.**

**PAYLOAD**

Half-A: Jr.—Gene Jackman, 9:06.8; Sr.—James Kohls, 9:03; Open—Frank Ehling, 15:31.4.  
Class A-B: Sr.—Michael Cook, 3:36.6; Open—Herbert Kothe, 15:19.  
Cargo: Randolph La Mait, 14½ ozs.

**TOWLINE**

Jr.—James Watson 12:03.2; Sr.—Robert Aldnk, 12:27.3; Open—Dick Everatt, 13:42.

**HAND LAUNCHED GLIDER, OUTDOORS**

Jr.—Gene Jackman, 6:44.7; Sr.—Bob Brawner, 16:44.6; Open—Ray Matthews, 15:25.1.

**STUNT**

Jr.—Harris Grimes, 324 pts.; Sr.—Don Ferguson, 389½ pts.; Open—Lew Andrews, 382 pts.

**WAKEFIELD**

Jr.—Don Tuno, 7:17.6; Sr.—Otto Heithecker, 6:40; Open—Joe Bilgri, 13:18.8.

**UNLIMITED RUBBER**

Jr.—Don Norwicki, 7:29.1; Sr.—Bob Brawner, 8:50.4; Open—Henry Cole, 15:00.9.

**RADIO CONTROL**

Jim Walker, 271 pts.

**NAVY CARRIER**

Bob Lutker, 225.45 pts.

**NAVY BOMB DROPPING (RC)**

Cifford Schalble, 99½ pts.

**CONTROL FLYING SCALE**

Jr.—Jimmie McCroskey, 22 pts.; Sr.—Juel Clavenger, 37.75 pts.; Open—John Abbott, 50 pts.

**JET**

Jr.—Tommy Davis, 132.35 mph; Sr.—Herbert Davis, 142.63 mph; Open—Thomas Baker, 140.73 mph.

**FLYING SCALE RUBBER**

Jr.—None; Sr.—James Caspar, 161 pts.; Open—Bob Bienenstein, 236 pts.

**TEAM RACING**

Bob Lutker.

**MISCELLANEOUS**

Taster Award, O. K. Anderson; Sportsmanship, Carl Goldberg; Club Champion, Detroit Balsa Bugs; National Champion, Paul Simon (Sr.); Junior Champion, Gene Jackman; Open Champion, Bob Bienenstein.



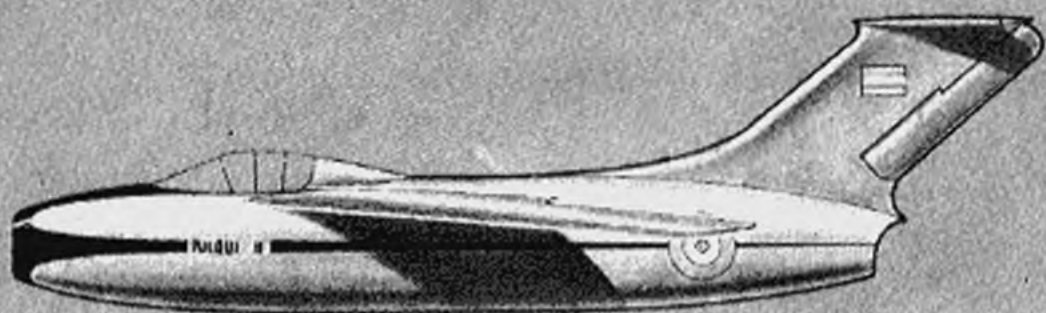

I. A. E. 33

"PULQUI II"

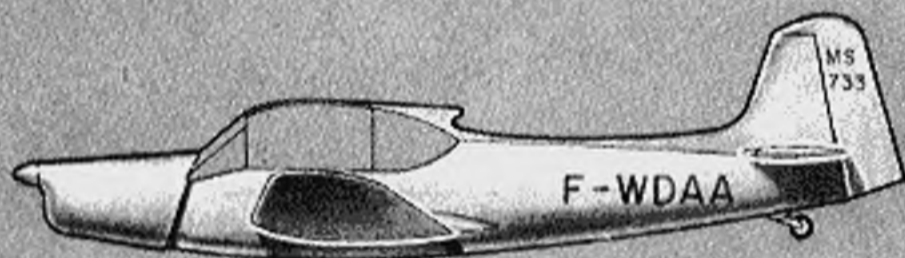
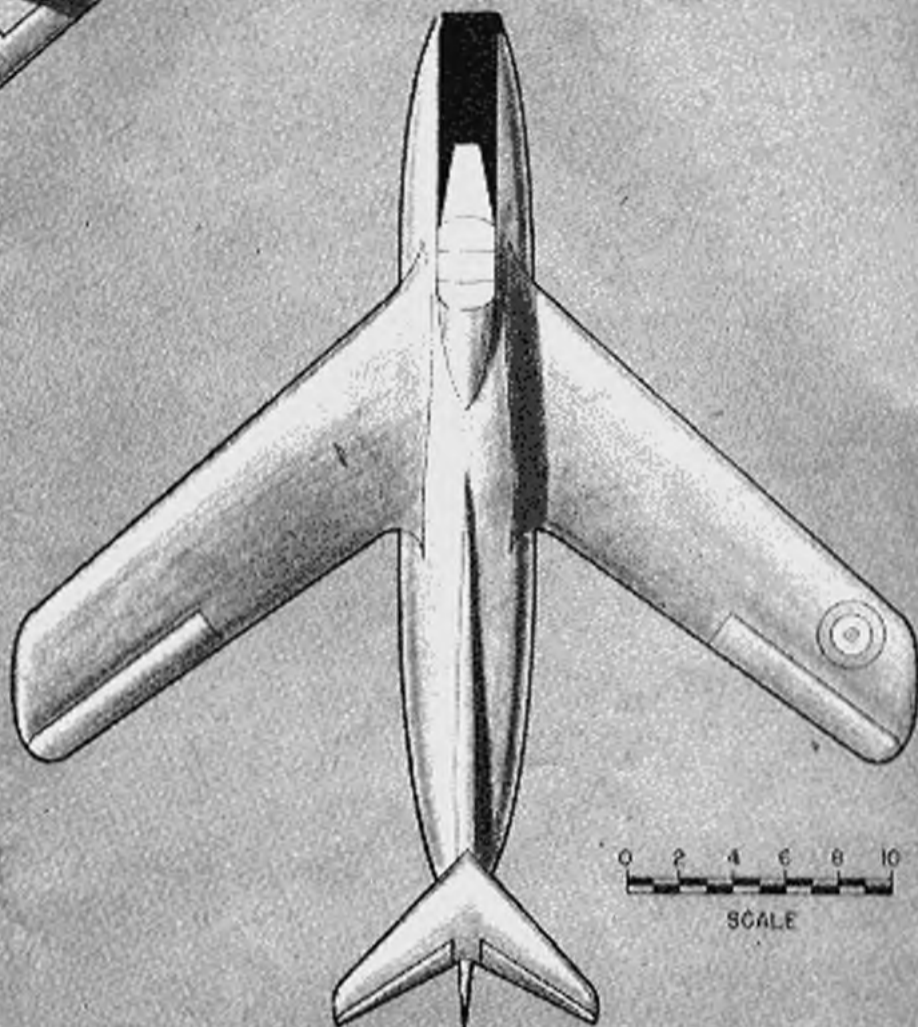
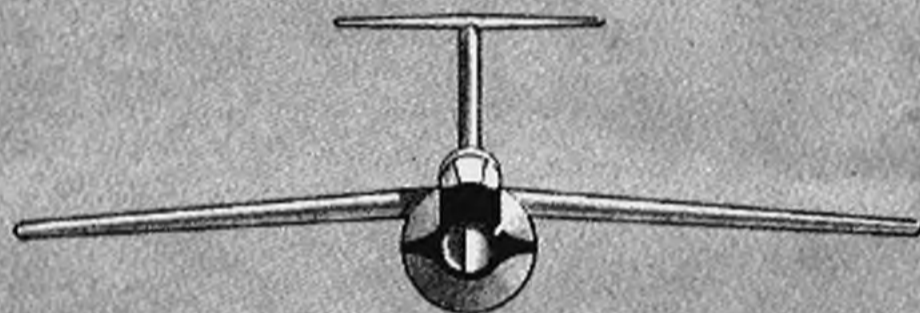

MORANE-SAULNIER  
733

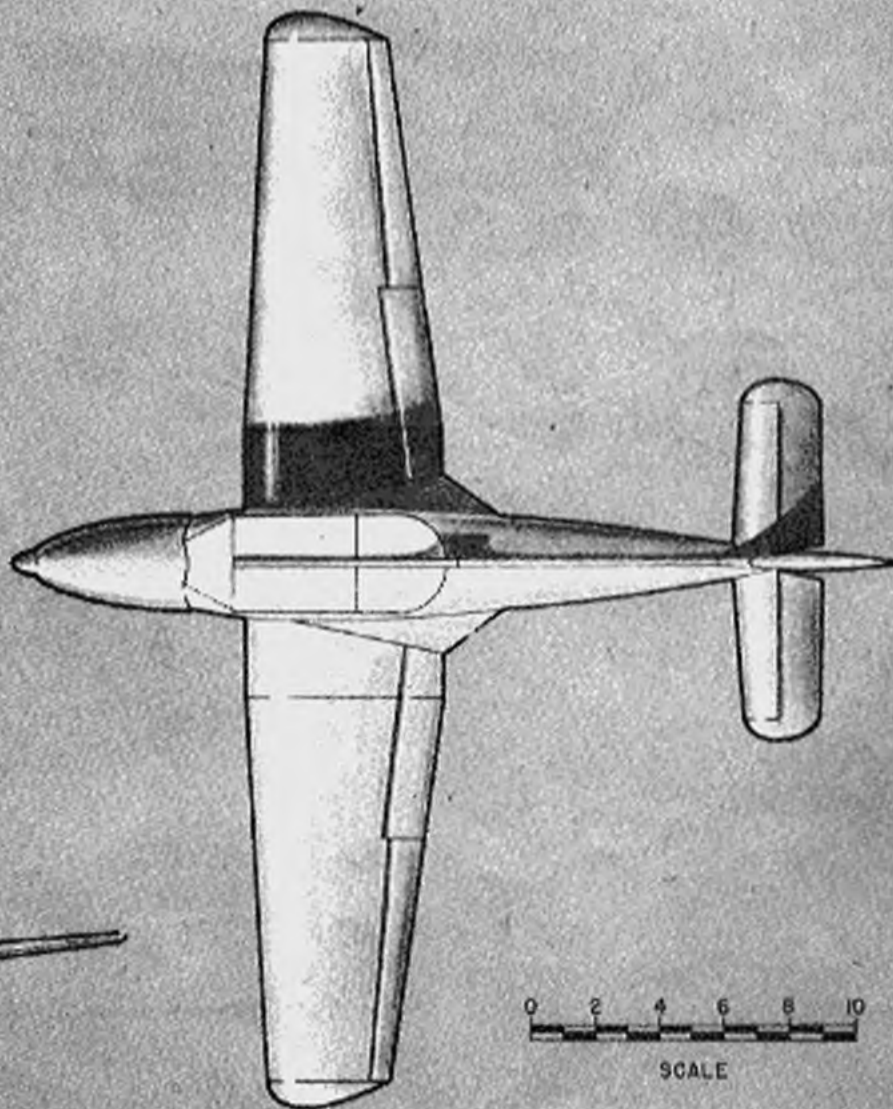
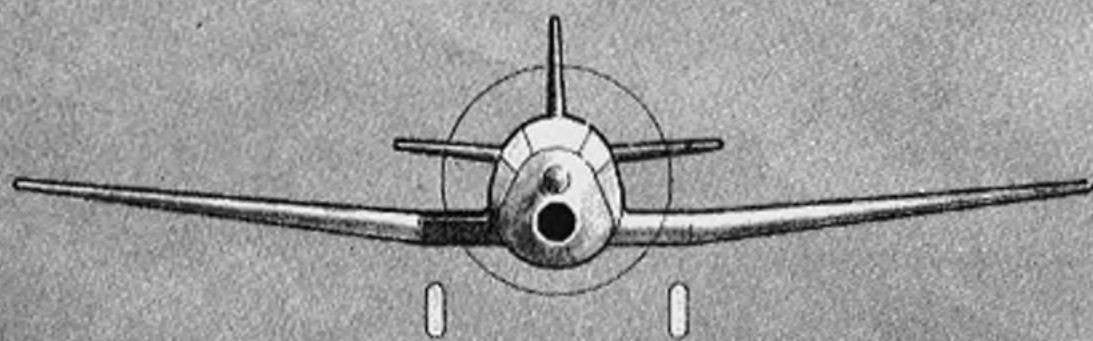

▶ September and school are synonymous, and thinking of school means thinking of education and learning. There are only a few ways to learn about airplanes—by theoretical studies (paper designs, they're called), windtunnel tests and flight tests of the actual craft. All of this is by way of saying that the beginning of school is a good time to talk about some of the research airplanes with which the services have been learning about flight at very high speeds.

First, the *Skyrocket*. This glistening white, rocket-propelled plane slammed through the thin blue air high above Edwards AFB, Calif. on June 11 to a speed and altitude never reached before by man and machine. The Navy and Douglas Aircraft Co. have claimed a new set of records for the craft's performance, estimated in some quarters as high as twice the speed of sound at 72,000 ft. That would mean a speed of 1,324 mph!

You'll remember that the *Skyrocket* (D-558-II) started out life as a combination rocket-plus-turbojet powerplant. Along about the end of 1949, the Navy decided that high-altitude speed runs would be of increased importance in its research program. So, plans were made to remove the turbojet engine and replace it with increased amount of rocket propellant.

This decision meant that the self-contained takeoff system of the *Skyrocket* had to be abandoned in favor of using a mother plane, in this case a modified B-29. Pictures of the mother craft show some extensive removal of fuselage structure, and the addition of a heavy external brace to take the loads across the cutout.

The powerplant on the record flights was Reaction Motors, Inc. LR8-RM-6 rocket engine, basically the same engine that powered the Bell (Continued on page 54)

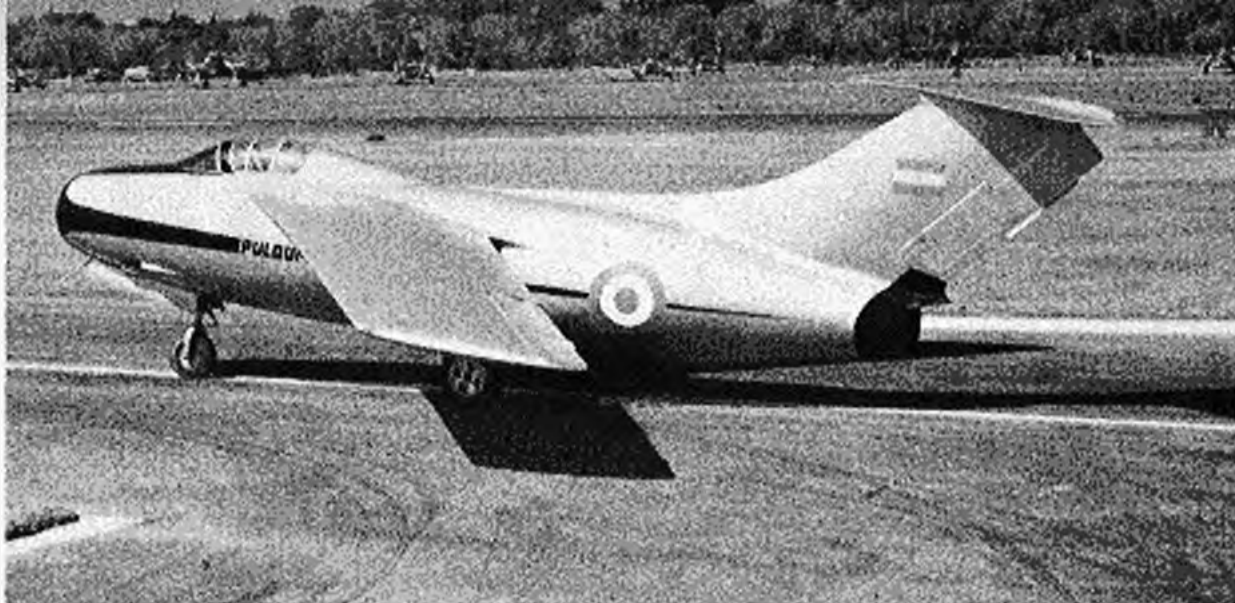

Argentina's Pulqui II is first-rate high-performance jet fighter. What makes it good is the presence of Kurt Tank, designer of Focke-Wulf 190, who now plies his art in the western hemisphere.

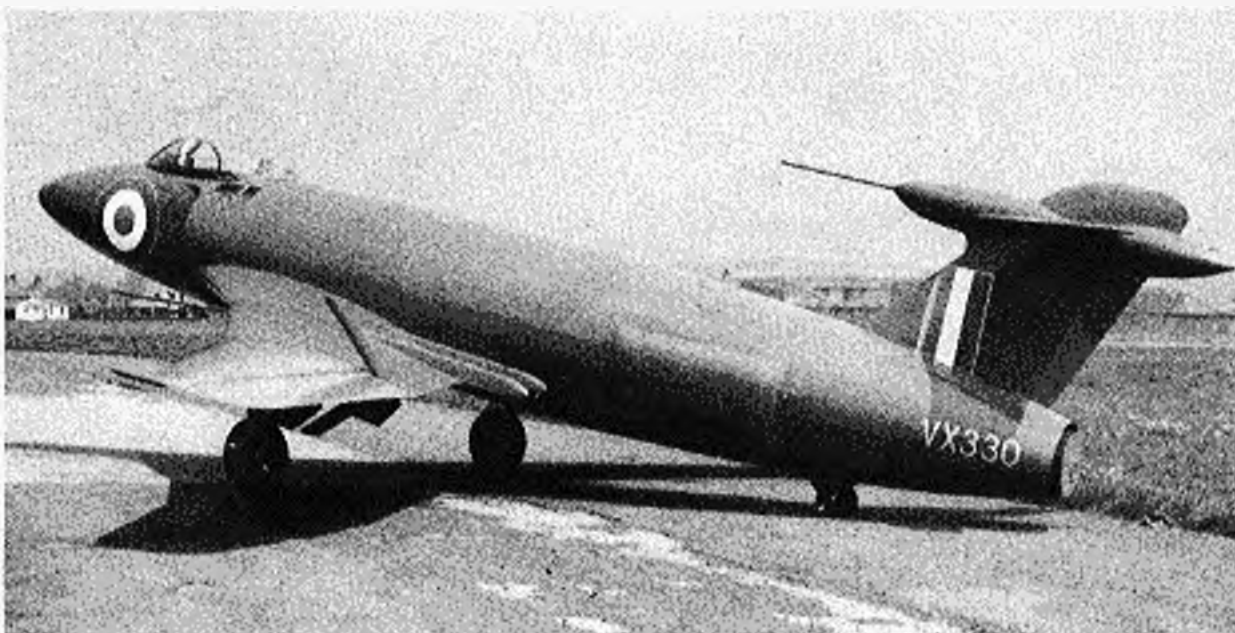

Mystery plane. Britain's new Handley Page 88 flies an experimental wing. The wing may be a scaled down version of that on a four-jet Handley Page bomber jet to come. The fuselage is an Attacker.



Shortly after this launching shot of the Douglas *Skyrocket* dropping from its mother ship was taken, the needle-nosed rocket job-jet was removed—set speed and altitude records estimated as high as 1,324 mph at 72,000 feet. Below—Take-off on the desert for an earlier speed run.

# planes in the news

by DAVID ANDERTON

Spectacular planes and flights abound as the wraps are taken off many mystery aircraft. Here's the story behind the story!

# air ways

## as seen at the Nationals



Howard Bonner about to release MacNabb equipped rc job. Two-speed K & B glow .19 really howls.



An excellent flying wing. Harry Robertson, gets a dose of wash-out.  
Bill Krecek letting go of his rubber scale entry, a Facka-Wulf Stosser.

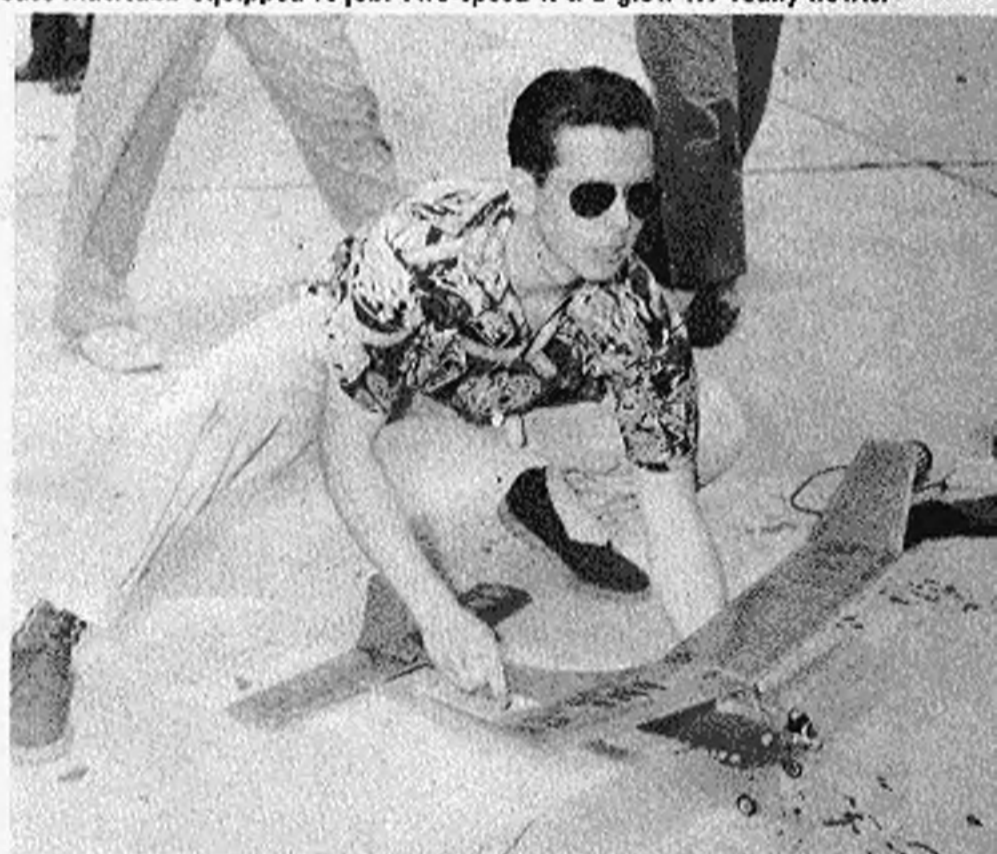

Law Mahieu rag's his new free flight design. Features novel raked wingtip panels.  
Sal Talbi with Class B free flight. Sal put in better than 27 minutes in Class A.





Ray Matthews, of Pay-load rep, prepares Fubar, one of his designs.

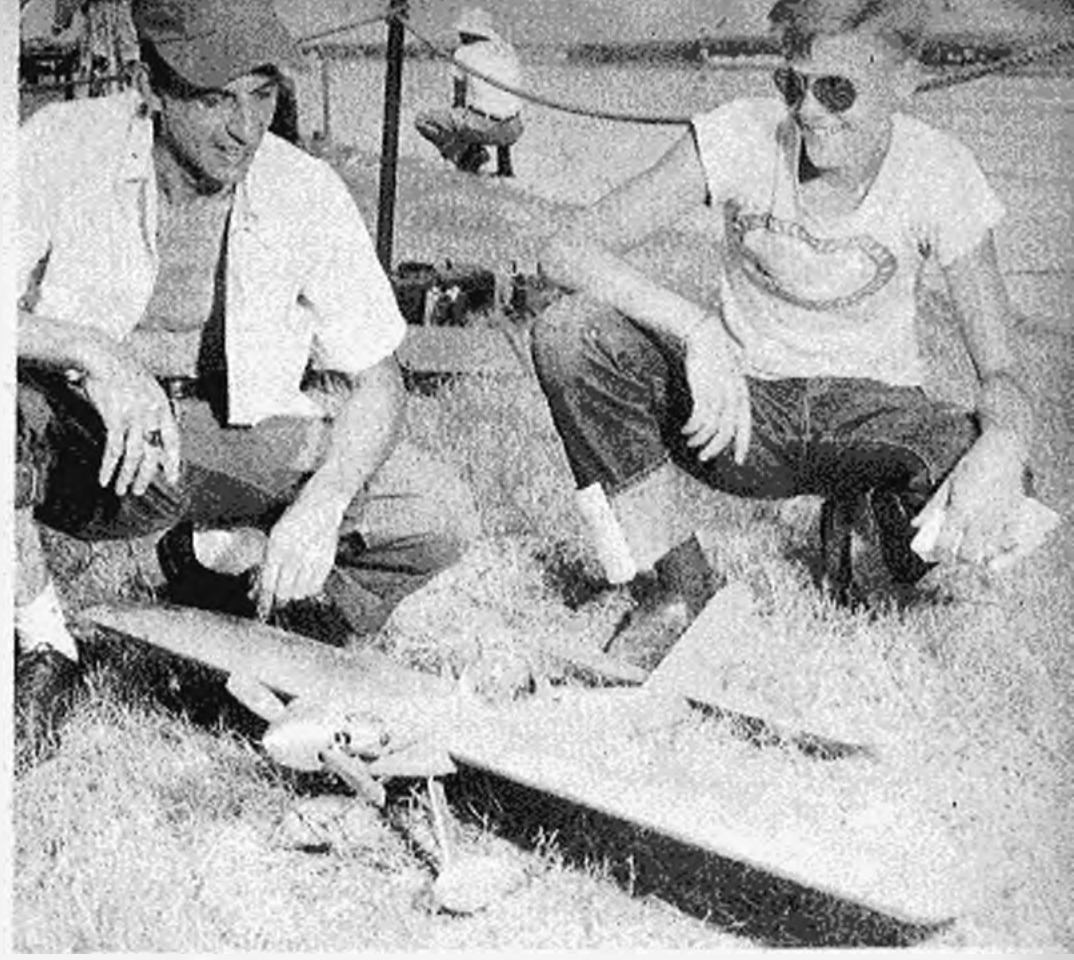

Open, Senior stunt winners, Andrews, Ferguson, flew Barnstormers.

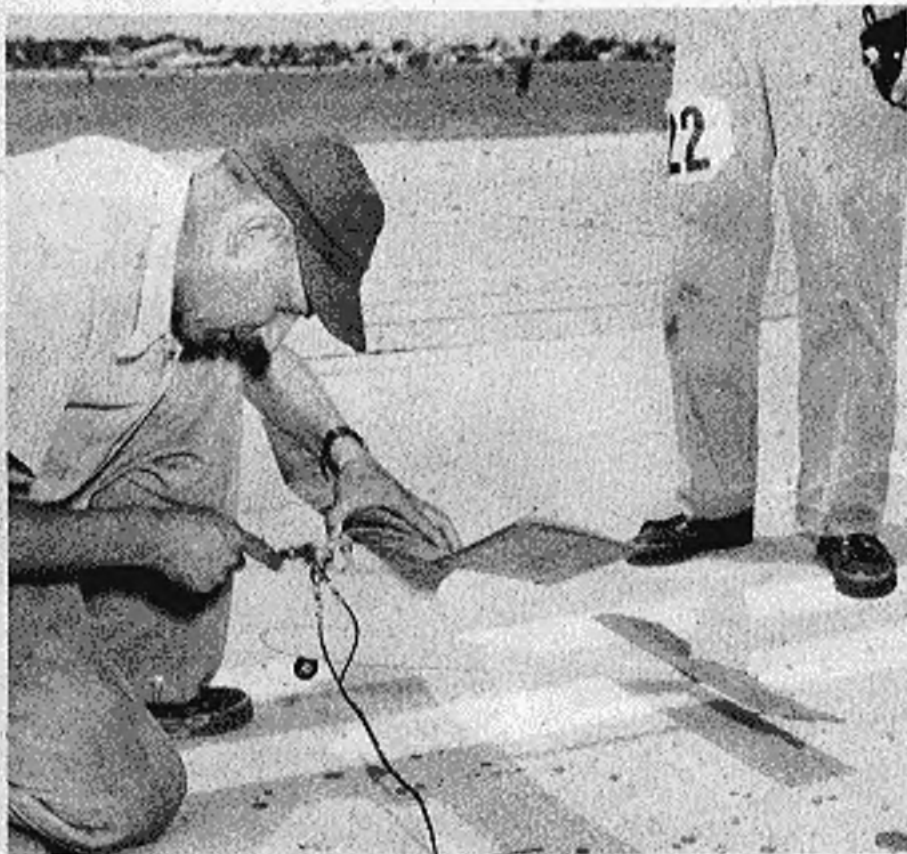

High-thrust line AA, flown by John H. Schneider. Hot performer, too.



Jim Carpenter — guess what club — turns loose his Class C entry in ROW event.

Frank Ehling looks determined with big Wakefield. Hank Cole took a first with this long Wakefield. Six K & B 049's, Sgt. Thompson's an B-36. Watta Jabl



Camera catches a few of the several thousands of outstanding airplanes flown in the numerous events of July 24-28 at the Dallas Naval Air Station. Complete story and pictures next month.

Phantom drawing reveals details of the engine and fan installation in a Lockheed fighter. Air ducts and exhaust tunnel and orifice must be properly arranged for efficiency. Note how the vanes behind the engine straighten out the turbulent flow of air from the fan. The long, pointed balsa fairing behind the motor also is essential. Larger engines should perform better.



## here come the JETS!

by THOMAS H. PURCELL, JR.



► The thrill of flying a scale F-90, F-7U-1, or a similar jet airplane can be realized at last. If you want to enjoy the sight of swept wings and propellerless noses climbing skyward this is where you can learn the trick. These models are realistic and simple to build. All you need is a good running glow ignition engine. The models that have been built to date use AA engines but larger engines can be used in larger airplanes.

The system is basically a ducted fan driven by a reciprocating engine. Certain modifications of the jet intake and exit sizes are necessary but these changes do not destroy the scale appearance of the model. Some elementary theory follows so that the designs and methods may be understood clearly.

It has long been known that shrouding a propeller increases its thrust at low airspeeds. The shrouding reduces tip losses and thus increases thrust results. Extending the shrouding for a length of several times the propeller diameter turns the system into a ducted fan. The propulsion device used to power these jet models evolved from the theoretical considerations as given by Glauert in *Aerofoil and Airscrew Theory*, Chapter XV. Glauert introduces the classical equations for propeller thrust from momentum theory. The thrust is assumed to arise from an increase of axial velocity imparted to the mass of air flowing through the propulsion system. The system diagram is shown on page 18. Glauert first proves that half the increase in velocity due to the actuator disc (or propeller) occurs in front of the disc and half behind the disc. Thus referring

to the diagram  $v = \frac{v_1}{2}$ . The thrust equation, based on momentum theory is  $T = \rho A (V + \frac{1}{2}v) v_1$ . Here  $\rho$  is air density and  $\rho A (V + \frac{1}{2}v)$  is the mass of air passing through the disc in unit time. Therefore thrust is mass flow times total increase in axial velocity.

Now Glauert also proves that the ideal propulsive

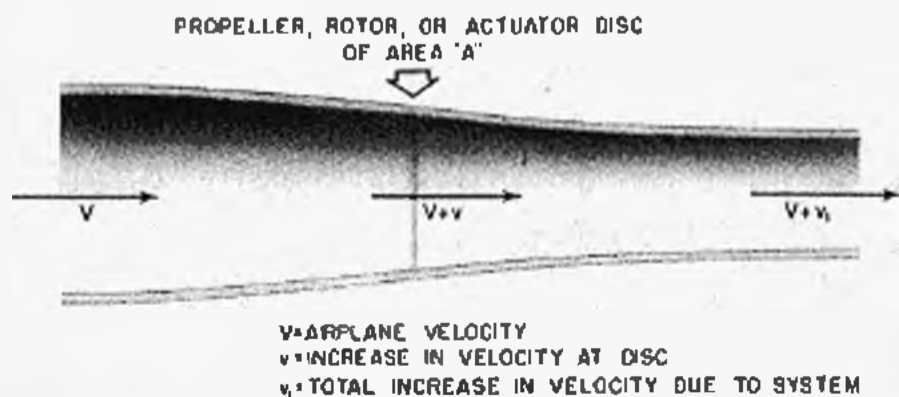

Top—The author launches a ducted fan model. Above—Figure 1, the basis of the deductions. Scale jet type models may also be flown by Jetax.

Why ruin the looks of that hot jet job by sticking an old fashioned prop on the back? The ducted fan makes it possible to fly those Migs, Sabres, even the Cutlass, by means of an AA engine.



Half-size patterns of two successful fans used by author. Specifications must be carefully followed for successful flying of jet planes.

efficiency of the system is:  $n = \frac{V}{V + v}$

This efficiency can be applied to a jet propulsive system by suitably modifying the equation.

Since  $V = \frac{v_i}{2}$ ,  $v = \frac{V_e - V}{2}$ , where  $V_e$  is the exit velocity of the system

$$\text{Then: } n = \frac{V}{V + \frac{(V_e - V)}{2}}; = \frac{2V}{V + V_e}; = \frac{2}{1 + \frac{V_e}{V}}$$

Thus the system efficiency is inversely proportional to "exit velocity/airplane velocity." This immediately indicates that the exit area should be fairly large for efficient propulsion. However, it cannot be larger than the inlet area or the thrust will be negative. It was found that the exit area could be almost as large as the fan area if model scale appearance was not destroyed. The inlet area should be about twice the exit area. All of the above considerations are based on the ideal theory involved and even the efficiency factor is an ideal one. This means that if the above discussed efficiency should come out 80%, then the actual efficiency would be somewhat less than 80% due to friction effects which have been ignored thus far. These friction losses occur in transferring engine energy through the fan to the air. This loss will be accounted for by applying a second efficiency to the system. Thus, terming the theoretical efficiency  $n_t$ , and the friction loss efficiency  $n_f$ , Thrust Horsepower =  $n_t \times n_f \times \text{Engine Horsepower}$ .

Now full scale propellers have a total efficiency of about 85% but it was believed that the small propellers on AA engines suffered high friction losses. On this basis it was believed that a ducted fan, which would not suffer these high friction losses, could

(Continued on page 40)

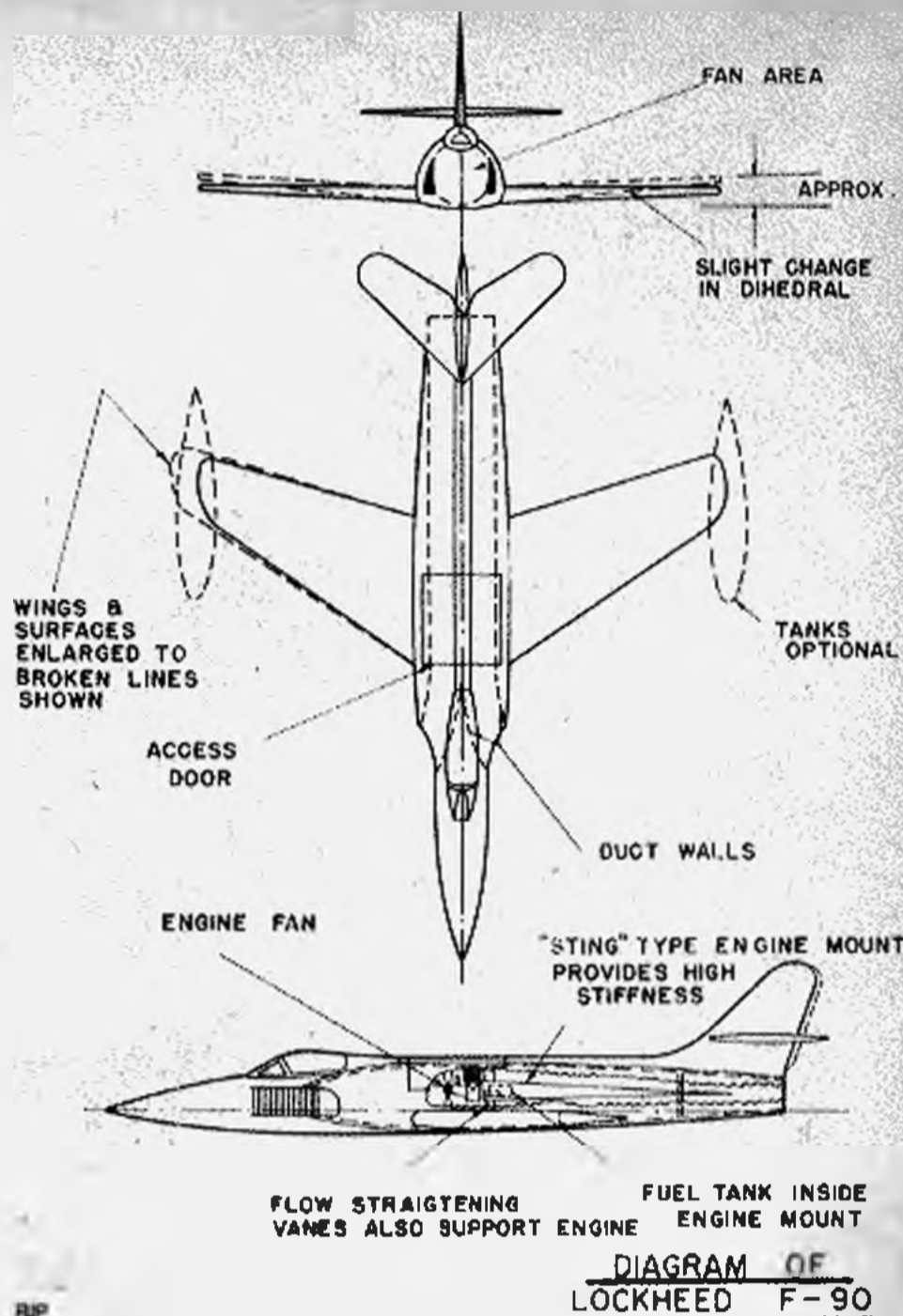

Three-view drawing of a proved Lockheed. Note engine, fan location. Below—Close-up of an .049 Wasp installation in a Cutlass. Note side intake screens. Bottle cap is handy starter. K & B and fan, also shown.

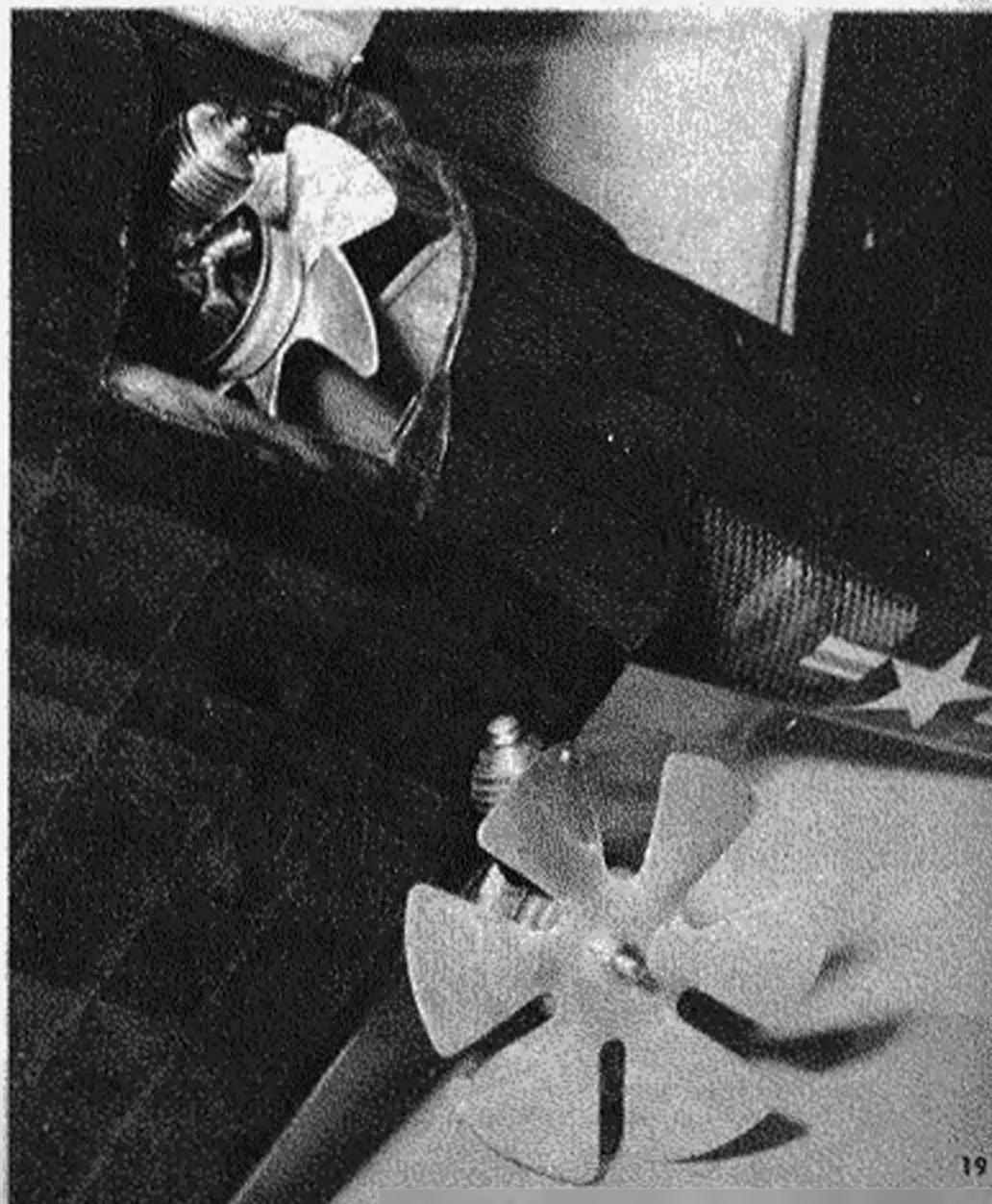

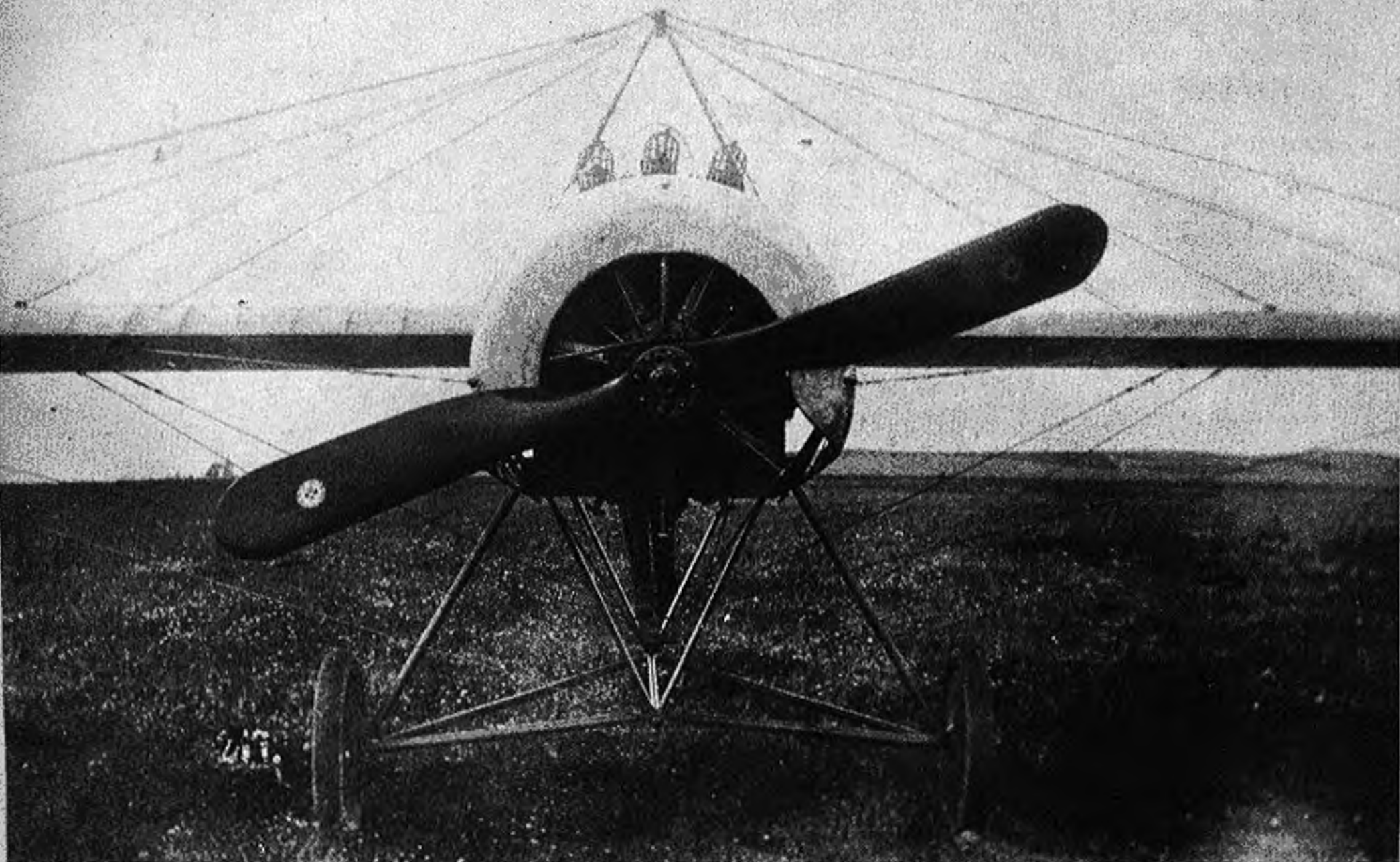

On the strength of the initial advantage of the Fokker E-1 and its synchronized guns the Germans built this special three-gun job for Max Immelmann.

## Fokker E-1

First synchronized-gun fighter in history, the E-1 had the Allies guessing for nearly five alarming months.

by ROBERT C. HARE

► It is difficult to describe the utter frustration, fear and anxiety experienced by Allied pilots, engineers and government procurement officers during the Spring of 1915. For what had for several months been a nice, peaceable, friendly air war, suddenly turned into a raging inferno of death for a score or more Allied flyers. The German airmen were using some new weapon. The effect of it was clearly understood; it was the cause—the method of applying the effect—that had the Allies stumped.

The cause was the first practical synchronized machine gun and the effect was a nearly complete demoralization of the French Air Service and the Royal Flying Corps.

The first synchronized gun monoplane was called the Fokker E-1. Although the die-hard German authorities accepted the device as practical, they demanded proof of

its ability to knock an Allied plane out of the sky before they would authorize production. Behind the synchronized gun was quite a story.

Probably no other single device had as great an effect on the development of the airplane during World War I. That the Germans were able to come out with it first and thus gain a temporary advantage in the air early in 1915 was pure happenstance. The best armament brains in Europe had been working on the problem of firing a gun through the propeller arc for years. August Euler had patented such a system in 1910 but it was never developed to the point of becoming practical. In Roumania, Georges Constantinesco just about had the problem licked, and in England, Sopwith and Kauper were on the verge of success. Even in America, Browning was close to the answer with an electrical synchronizing system.

Ironically, the problem of synchronization, which the best armament men of the belligerent nations were trying to master, was solved by Anthony Fokker, a national of neutral Holland!

It all began with a young sportsman named Roland Garros. This tempestuous fellow was a daredevil in every sense of the word. At the outbreak of war he offered his services—and his little Morane monoplane—to the French government. They accepted him, gave him a newer type Morane and turned him loose over the lines. He soon discovered he couldn't "out-spot" the enemy observation pilots who were his counterparts, came to the conclusion that the idea was to prevent the enemy from finding out where and what was going on behind French lines. So he went up in his little Morane one day with a Lebel automatic rifle, and exchanged some shots with an equally enterprising German pilot.

Garros came to a

(Continued on page 38)



Powered by an 80 hp Oberursel, E-1 had wing warping lateral control.



FROM A HISTORICAL TRANSMISSION IN THE JOURNAL OF AVIATION, THE GERMAN FOKKER E-III OF 1915 IS REPRODUCED IN THE WALL OF CAMBODIA MILITARY AIRCRAFT-MUSEUM BY MOST SELECT GERMAN AIR PILOTS IN THAT KEY. IT WAS IN THE HANDS OF GERMANY'S FIRST ACE, HART DANKELMANN, THAT THE E-III MADE HISTORY. HE FLEW THE E-III WHICH SECURED HIM SUPREMACY OVER THE ENEMY UNTIL HIS DEATH JUNE 18, 1915. DUE TO THE DEFECTIVE ACTION IN THE FOKKER MECHANISM OF HIS TYPE E-III, DANKELMANN'S FINDINGS IN THE FOKKER E-III, AS SPOURED EARLY IMPROVEMENTS IN AVIATION AIRCRAFT AND TECHNIQUE.

BLACK CROSS ON SOLID WHITE CROSS, LONGER THE WINGS. LONGER THE WINGS. LONGER THE WINGS.

FUEL QUANTITY GROSS ENCLOSED BY METAL BONNET.

ACCESS DOOR TO ENGINE DRIVE FUEL & OIL PUMPS

ACCESS DOOR TO THROTTLE VALVE.

SCROLLSHEET DURALUMINUM BONNET, ASSE COM. LINE SCOTCH & PAPER. ENCLOSED HOSE SECTION TO LONG SWAYN. REPAIRING FORGE WAS USED.

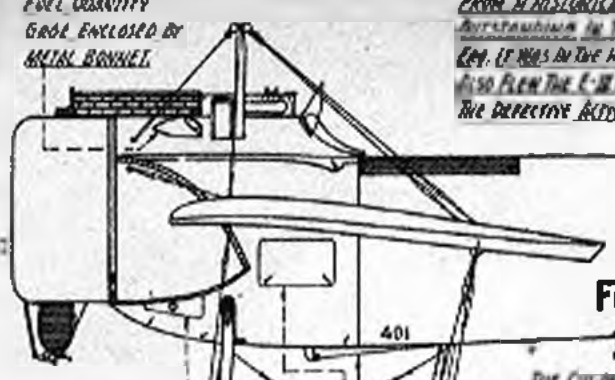

Fok.E III 417/15

WHITE FIELD.

THE COUPLER AT RIGHT PRESENTS THE MOST VITAL PARTS OF THE FOKKER E-III. THE MOST IMPORTANT BEING THE SUN SYNCHRONIZATION TRANSMISSION "D", WHICH TRANSMITS POWER FROM THE ENGINE-DRIVEN CAM ROLLER TO THE MECHANISM WHICH FEEDS THE MAIN GEAR. THIS MECHANISM ITSELF OPERATES FROM RECOIL.

FRONT VIEW OF THE FOKKER E-III. THE ENGINE AND WING... LUBRICATOR... WAS GIVE PIECE & FORGED ON A TOOL. SCREW WITH THE TOOL OF THE POSTAGE, RUNNER, LUBRICATOR ATTACHED BY ITS ONLY SPIN...

REAR VIEW OF THE FOKKER E-III. THE ENGINE AND WING... TO A TYPICAL... MAIN FUEL TANK WAS SHIPPED & CLAMPED TO FRAME.

PILOT'S SEAT WAS... BOUNDABLE... FUEL TANK WAS... 164"

CONNECTIONS WRAPPED WITH... 29 1/2"

WING SPAN 33'2"

AT LEFT IS... 15 1/2"

RECOIL... 15 1/2"

OPERATIONAL... 15 1/2"

ALL PARTS... 15 1/2"

SCALE: 3/4" = 1'-0" FULL SIZE: 3/4" = 1'-0" DRAWN BY: Joseph Nieto.

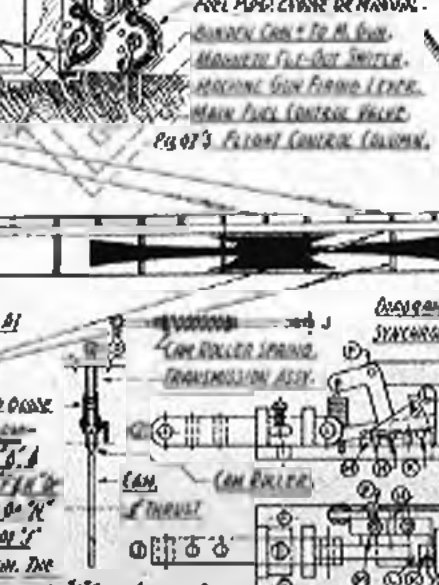
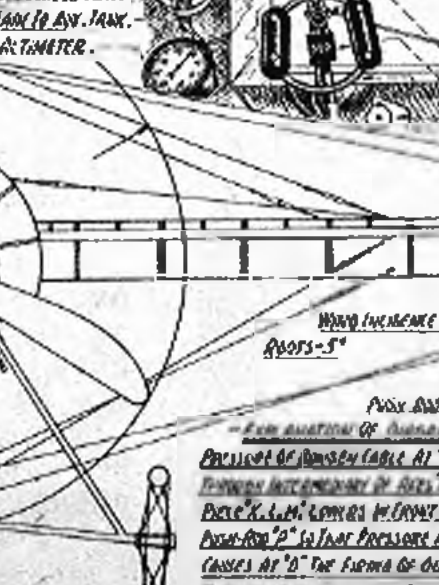
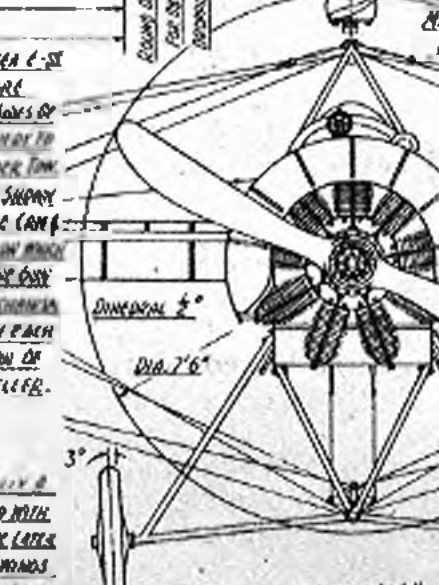
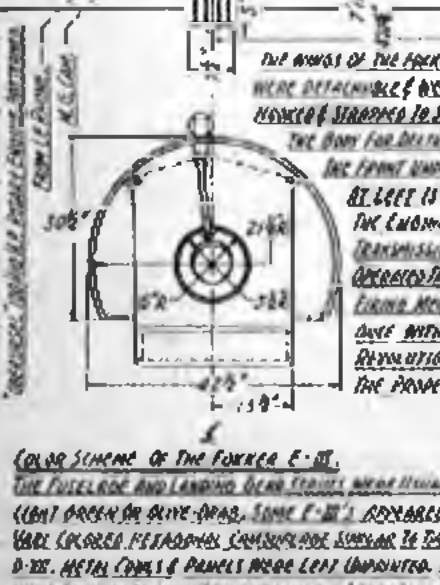
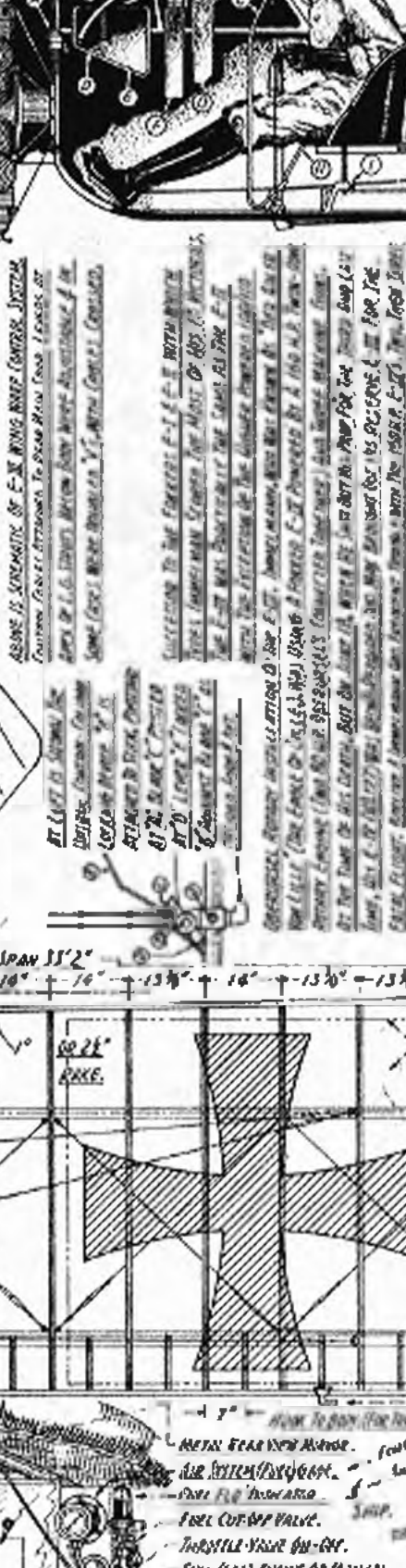
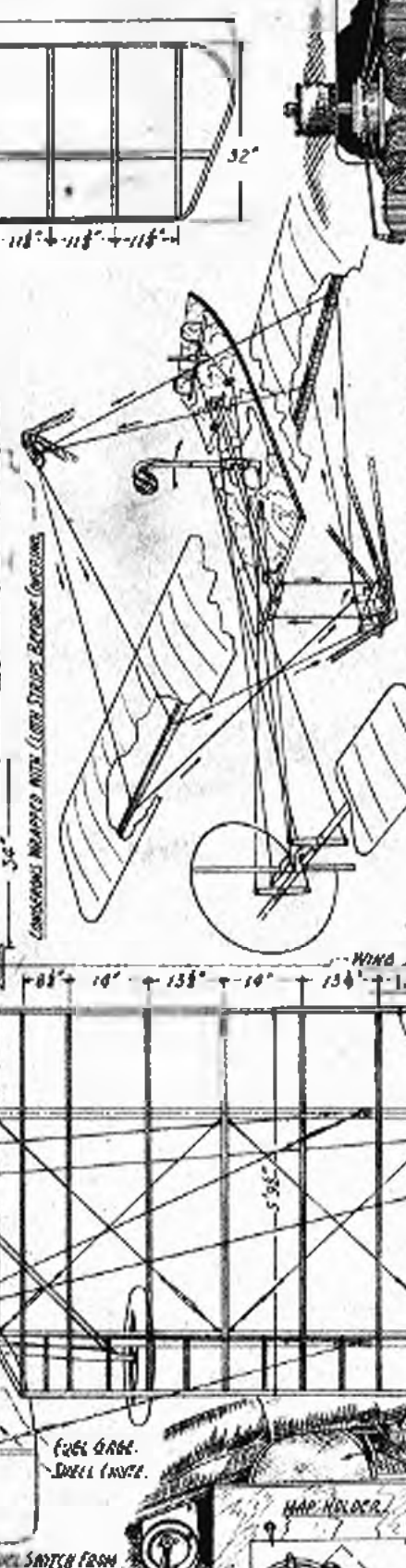
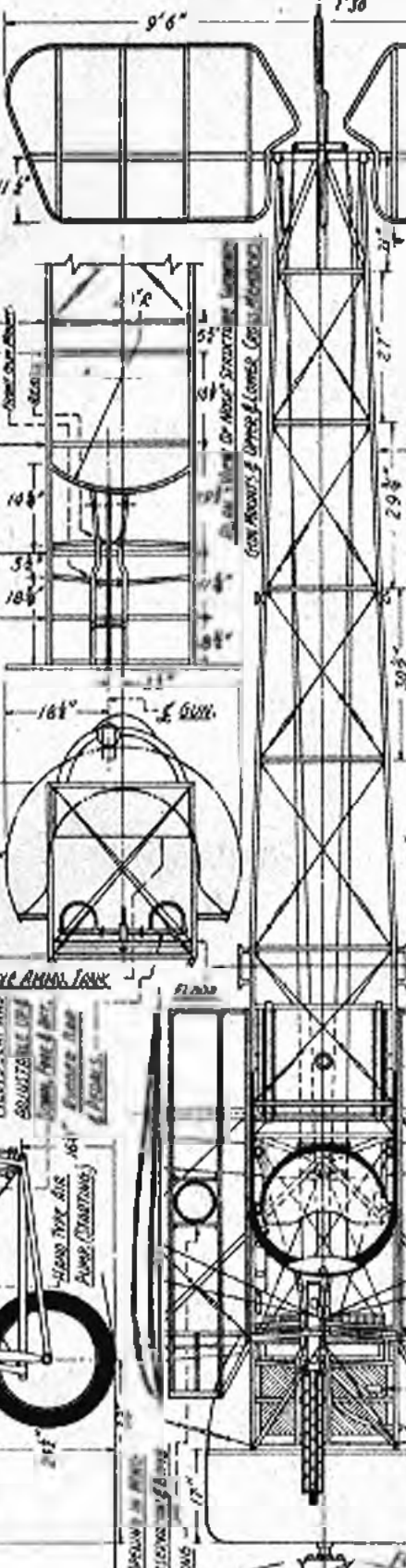
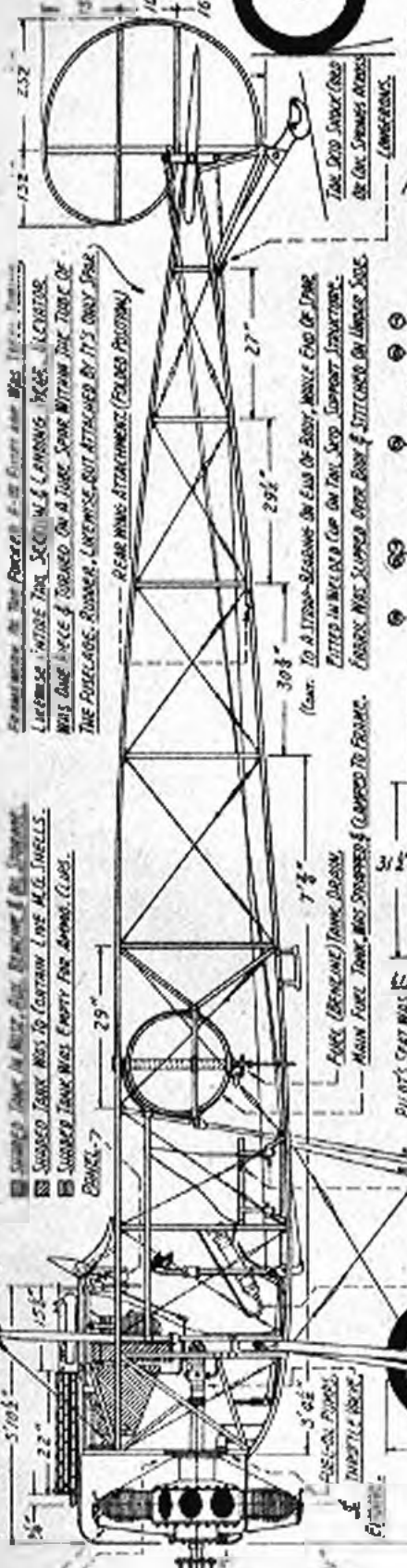

COLOR SCHEME OF THE FOKKER E-III. THE FUSELAGE AND LANDING GEAR SHOULD BE PAINTED IN LIGHT GREEN OR OLIVE DRAB. THE E-III'S COPIES SHOULD BE PAINTED WITH VARIOUS COLORS. METAL PANELS SHOULD BE PAINTED IN THE LATER D-III. METAL PANELS SHOULD BE PAINTED UNPAINTED. WINGS SHOULD BE PAINTED LIGHT GRAY UNDERNEATH. ONLY GREEN PAINT.

THE WINGS OF THE FOKKER E-III WERE DETACHABLE & WERE HOISTED & STRAPPED TO SIDES OF THE BODY FOR DELIVERY TO THE FRONT UNDER TOW. BEL LEFT IS SHOWN THE ENGINE CAM TRANSMISSION WHICH OPERATES THE SUN SYNCHRONIZATION MECHANISM OF THE PROPELLER.

WING INCREASE BY 100% AT 5' 00"

Diagram of the main sun gear & synchronization mechanism of the Fok.E-III.

Diagram of the main sun gear & synchronization mechanism of the Fok.E-III.

AIR AGE INC. 5511 FIFTH AVE., NEW YORK, N.Y. SCALE: 3/4" = 1'-0" FULL SIZE: 3/4" = 1'-0" DRAWN BY: Joseph Nieto.

Fok.E III



This is the Testor 29 Senior built by the author.

## we test the senior

▶ With the Seniors, Testor Chemical Company winds up its series of progressive steps in building and flying of U-control planes. Four steps and three different size planes in each step make up the series to conform with different engine sizes from .090 to .29 displacement. The discussion here is only on the Senior 29 although the comments and information are applicable to the Senior 9's and 19's.

The Senior 29, a stunt model designed for the .29 engines, can also be used as well with a .32 or .35 displacement. It is comparatively light and would do well with a .23 or .24 and some of the .19's.

The wing span is 40", average chord 8" and the wing tapers in thickness from 1-3/8" at the center to 1-1/4" at the ends; length is 28" with spinner. Complete with engine and painted, the Senior weighed in at just under 1-3/4 lbs. without landing gear and just over 1-3/4 lbs. with the gear.

The kit features the Testor's "Key-lock" construction and molded balsa fuselage sides. These features have very good possibilities for future development in their gas model line. The

kit includes hardware, wooden wheels, plastic canopy, pre-shaped and die-stamped parts. Full size, two-view plans with a fair amount of detail, a large sheet of step by step instruction, and detailed sketches are included. These will be discussed later. The control mechanism is the Jim Walker type.

For test purposes the model was flown with a McCoy 29 Redhead, K & B Torp .29 and Fox .35, using both Testor's 39 fuel and K & B Supersonic 100. Ten-six props, both Testor's and Top Flite, proved the best size. All combinations proved satisfactory on both 60 and 70 foot lines.

What tank is used depends on the engine selected. The McCoy Sportsman, for instance, is a front rotary type, whereas the Redhead is a rear Venturi type. The former leaves unrestricted space for a tank, but for the latter engine, we made up a square tank of the stunt type with the two vents facing forward to gain the greatest possible engine run.

When the Senior 29 was first selected for the "We Test" series, and the kit was checked, it was felt that it



Above—Wheels up! This action shot was taken during the inverted flight portion of the pattern.

Right—Jim "No Nerves" Fluharty fires up the Senior prior to putting it through the pattern. Flown by various pilots, the test model came through unscathed. It has a moderate-area.



offered something different and new in construction. However, the wing and tail area, less when compared with most of the existing precision stunt ships, seemed to make it a questionable top class ship, although it obviously would be a good flyer. We were wrong! The performance, as we built it, was well above expectations. It won't go around on a dime and leave nine cents change, but that is a point of debate. The trend in stunt is for precision-smooth loops, eights, and stable flight. Check the rules, use the space specified and you'll have one of the smoothest flying ships you've ever seen.

It is advisable to stack the ribs, left and right, side separately before inserting in place. Line up the main spar slots and check for equal graduation of the ribs out toward the tip—also for evenness of the leading edge notches and leading edges that will receive the planking. Trim and sand if necessary. This is important for a smooth job. Next, check the fit of the ribs in the main spar keylock slots, making sure the ribs are vertical. It may be (Continued on page 44)

by DON GROUT

Featuring molded balsa shell fuselage sides, the Testor Senior .29 was tested with McCoy, Torp, and Fox engines. The test model performed the full pattern, held out on overhead eights, is a precise, smooth, not jerky, flier.

Three-view drawing reveals realistic planforms and streamlining of the Senior. One interesting feature is the side mounted engine. In crack-up, rightside up or inverted, cylinder does not hit.

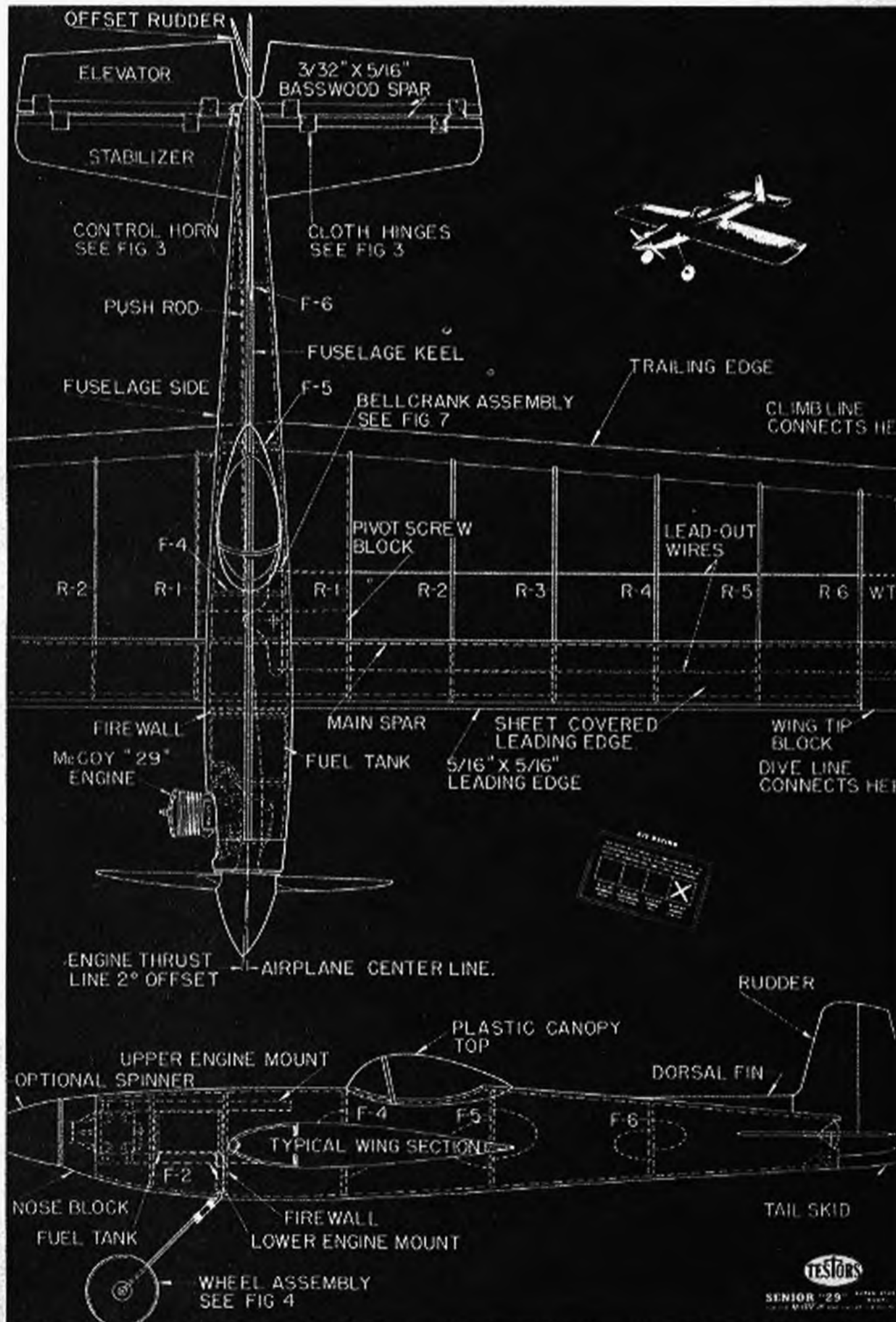



Built in all sizes from AA jobs to big "60's," the Ringmaster has proved its ability. Wing construction features an I-beam, sheeted edges; fuselage has sheet sides, extra long motor mounts.

## RINGMASTER

FOUR YEARS OF DEVELOPMENT WENT INTO THIS HIGH PERFORMANCE STUNT JOB, FOR ENGINES OF .19—.35 DISPLACEMENT.

Wheel pants, bubble canopy, dorsal fin and Oswald the pilot, add a note of pleasing realism, yet stuntability rates with that of flip-flopping "barn doors."

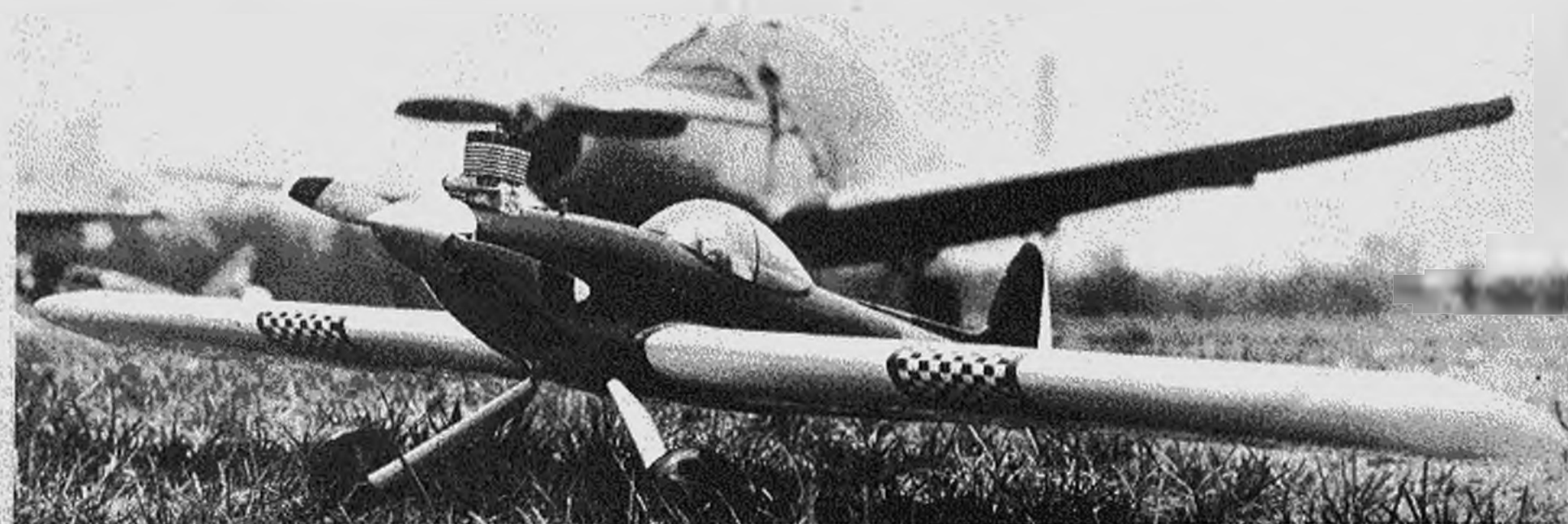

by HARRY WILLIAMSON

► The *Ringmaster* is a tried and proven stunt ship that originally took to the air in the summer of 1947. In the four years that have passed since that day, we have built many of these ships and with some changes, structurally and aerodynamically, have produced the version you see here.

This design has been scaled up for the big "Sixties" and down to the tiny "A" jobs. Regardless of the size, it has proven its ability. Speed, strength, appearance and full-pattern ability are its features. Although designed for the K & B 29, the version shown on the drawings has also been flown with the McCoy 36 and will turn in a very creditable performance when flown with O & R 23's.

Construction is conventional and quite simple, even for the less experienced. The wing is of the single I-beam spar type, with sheet covered leading and trailing edges. Fuselage construction is a glorified box with flat sides and bottom and a rounded, planked top. Engine mounts that extend two-thirds of the wing chord, offer that much-needed strength in a crackup.

**Fuselage Sides:** Select two pieces of 1/8" hard sheet balsa and cut out the fuselage sides. Two nose reinforcement pieces are made of 1/16" plywood and cemented to each side. Hardwood mounts, 3/8" x 1/2", are cemented in place and additionally strengthened with #2 flat-head wood screws, through the mounts and into the plywood. Cut out each side for the wing and lay both halves aside.

**Wing:** This part of the airframe, since it takes all the flight loads in those violent maneuvers, requires a great deal of care to obtain maximum strength and efficiency. Cut out 20 ribs from 1/16" hard sheet balsa and sand to shape. Two pieces of 1/8" x 1/2" hard balsa strip form the upper and lower halves of the I-beam spar. Pin one piece of 1/8" x 1/2" to your workbench and cement the ribs in place. Before allowing the cement to harden, cement the lower half of the trailing edge to the ribs and correctly align the assembly. After sufficient drying time has elapsed, the top half of the spar and the leading (Continued on page 46)

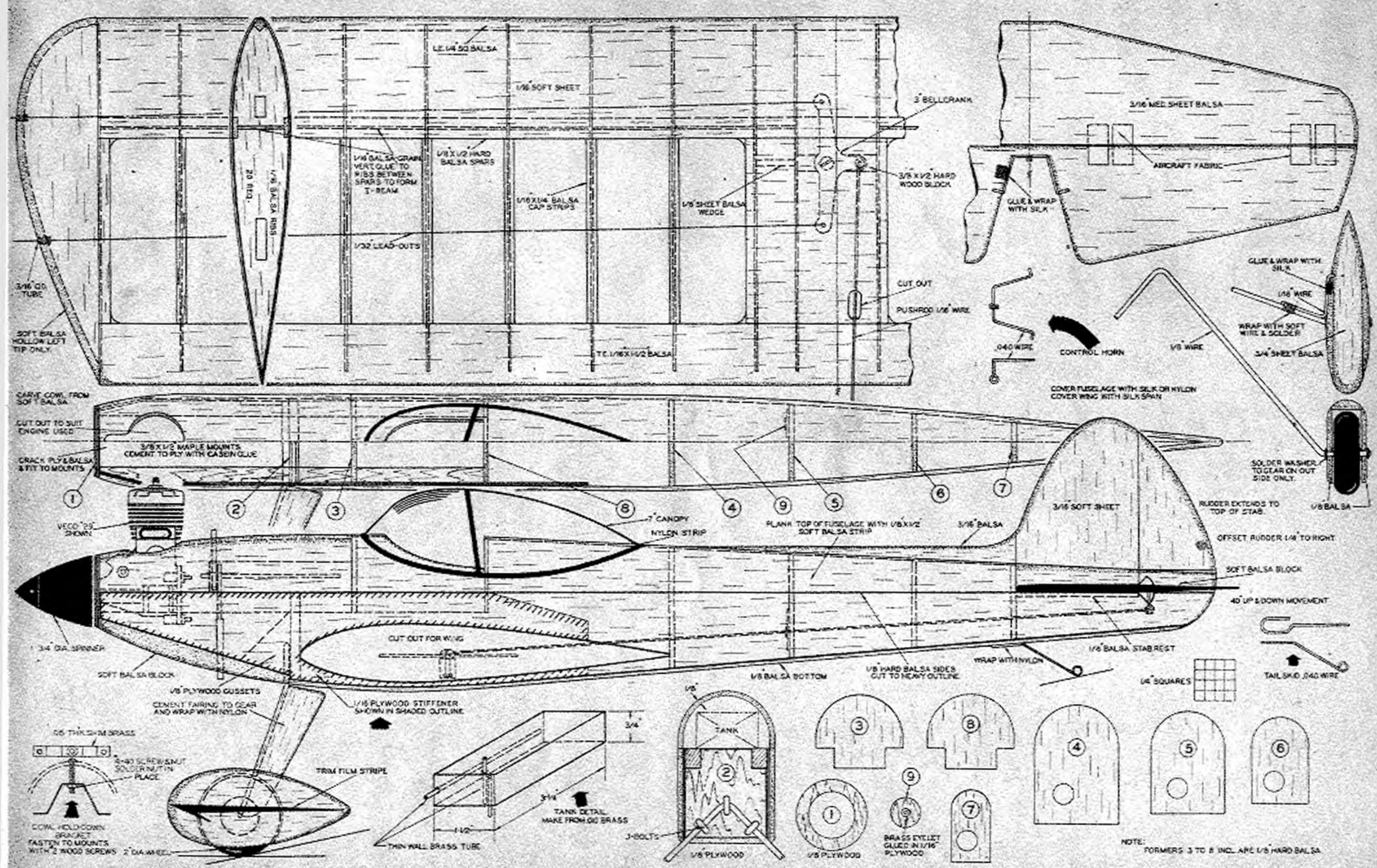

FULL-SIZE PLANS FOR BOTH "RINGMASTER" AND "GEE BEE" AVAILABLE. See Page 50.

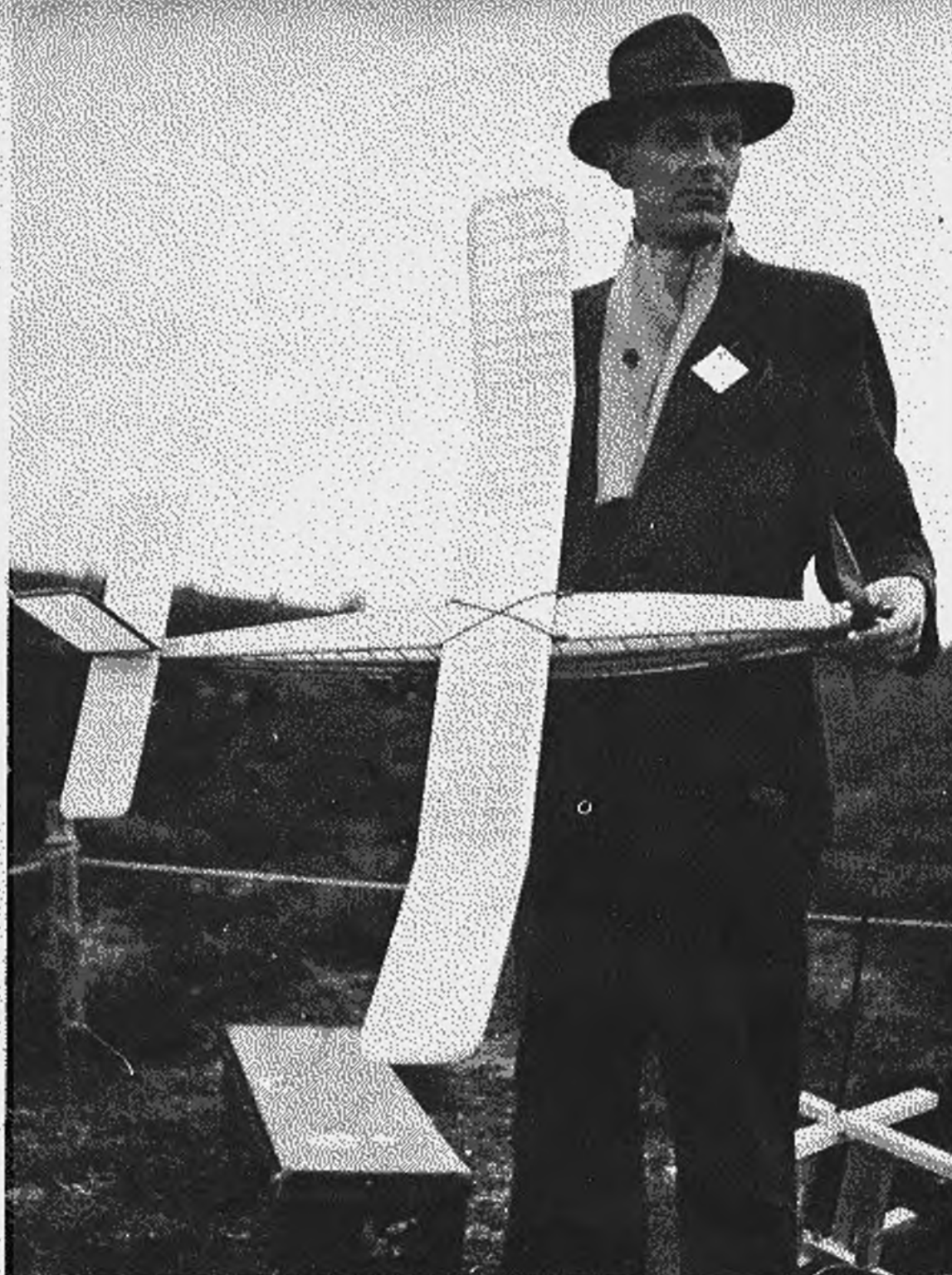

Hail to the victor! Flying this simple geared job, S. Stark's flights were remarkable for their consistency, times going up as weather deteriorated. Stark is no newcomer.

FIRST ROUND		SECOND ROUND	
1. de Jong	258.1	1. des Chappor	243.4
2. Tubbs	252.7	2. Tubbs	236.9
3. Gilg	236.0	3. Cassola	236.0
4. Stark	226.2	3. de Kat	236.0
5. Andrade	226.0	4. Stark	232.5
5. Lustrati	226.0	5. Lustrati	229.1
6. Woodhouse	224.0	6. Leardi	228.3
7. Ferber	223.5	7. Hofmeister	223.6
8. Holland	221.7	8. Borjeson	217.5
9. Paintel	218.0	9. Dijkstra	215.1
10. Dowsett	215.9	10. Pelegi	211.7

The round-by-round results show clearly that consistency is a major factor. Stark, who won, was fourth on both flights.



The Dutch team. Dutch are European rubber champions and always do well in the Wakefield. Their J. de Jong took fourth.

# How Sweden Won the Wakefield

by RON WARRING

**On the basis of D-day minus one test flights, American jobs were rated favorites, but weather and skillful flying by four top winners dropped Austin Hofmeister to fifth place. Analysis of the winners.**

► Return gears? A long fuselage with taut motor between hooks? Or just a conventional model? These are the three alternative layouts which Wakefield enthusiasts have to ponder for the 1952 event which will again be in Scandinavia, or the northeastern corner of Europe. A Swedish geared model won the 1951 contest with an excellent example of consistent flying but the models which really impressed and caused the greatest interest were undoubtedly those of the American team. On the basis of test flights the evening before the event, it seemed almost certain that either an American geared job or an American long fuselage design would come out on top.

What changed the situation on the day of the contest was the weather. That still 'dead' air just did not come. For the first two rounds the air was relatively calm low down, but with a fairish drift above about a hundred feet or so. On the first round, too, there was definitely lift around, if you got up high enough to find it. By the early morning, starting at 3 a.m., the wind had swung through 90 degrees and was now blowing a stiffish breeze. As a consequence, the American models trimmed for dead still conditions were just that bit out of trim for Finland! The Finns themselves were unable to explain it. For the past two or three weeks the weather had been abnormal with winds in the evenings instead of dead calm, and tem-

peratures lower than average. Ellila himself was caught out on this score for he brought a new model along to Jamijarvi a week before the contest and just had no chance at all to put it into the air until the day before the event. He was using the new model, still obviously untrimmed, and promptly recorded a 'no flight' (under five seconds) on his first contest attempt. Flying his reserve, he could only manage a very modest official time of 130 secs. His second flight, with his new machine repaired, again resulted in a stall into the ground—the timekeepers promptly clocking off at 0.9 secs—after which the model bounced off into the air once more and flew for some further two minutes. He did not bother to take his third flight.

S. Stark of Sweden, the winner, put up some remarkably consistent times, perhaps even more significant because as weather conditions deteriorated, his flight durations went up. His last flight of just over four minutes placed him thirty seconds above H. Tubbs (G.B.) whose flight times went down each round. S. Lustrati of Italy placed third; J. de Jong of Holland fourth, with A. Hofmeister (U. S. A.) close behind with some more consistent flying for fifth place. These five were really the outstanding performers although probably the most impressive flying was by the two American long fuselage jobs favoured by the Californian boys Foster and Andrade.

THIRD ROUND		RESULTS	
de Vries	256.5	1. Stark (Sweden)	705.2
Stark	246.5	2. Tubbs (G.B.)	676.2
Lustrati	209.1	3. Lustrati (Italy)	664.2
Andrade	208.3	4. de Jong (Holland)	653.9
Hofmeister	204.8	5. Hofmeister (U.S.A.)	629.4
de Jong	189.8	6. de Vries (Holland)	621.6
Holland	187.4	7. Andrade (U.S.A.)	614.8
Tubbs	186.6	8. des Chapper (Belg.)	609.6
Dowsett	166.7	9. Holland (G.B.)	598.6
des Chapper	164.0	10. Cassola (Italy)	598.2

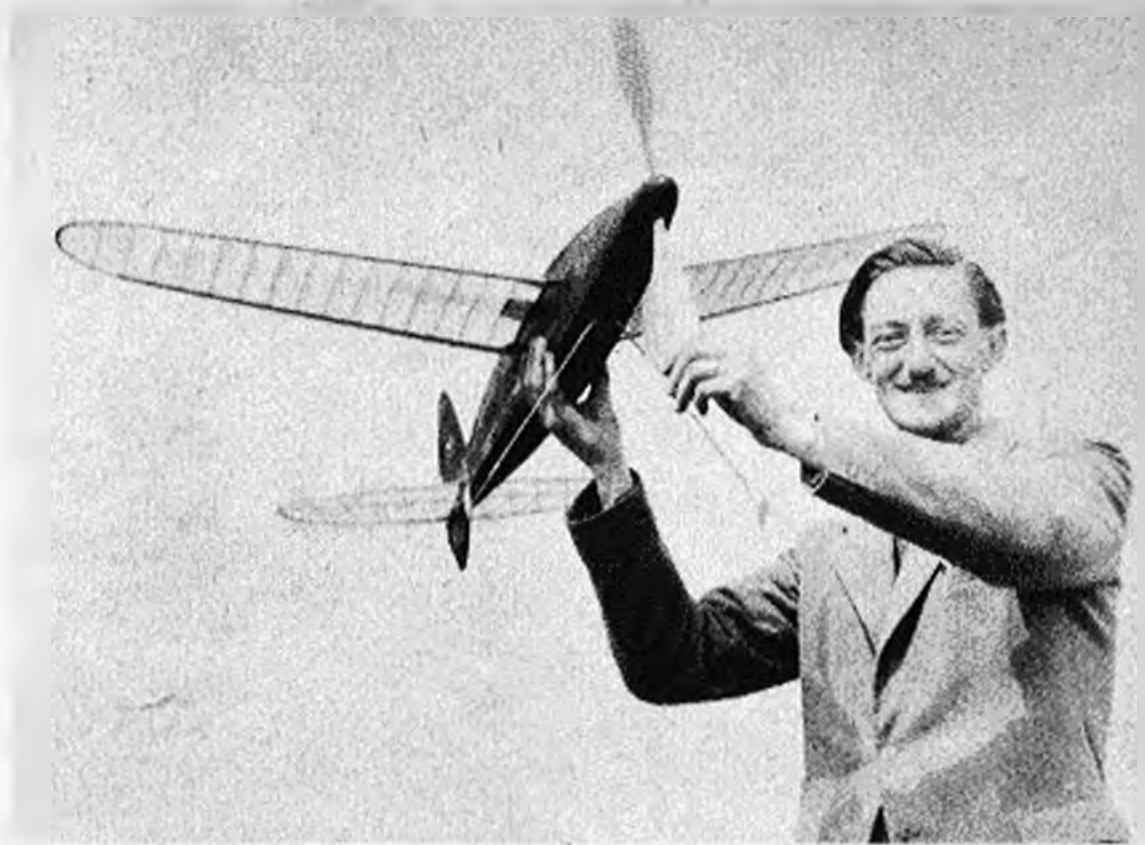

Britain's Frank Holland with a typical faired slabside. H. Tubbs took second for England. Only three fliers, including Hofmeister, did better than 200 seconds each round.

and second rounds, second on third round. Next year's U. S. planes may combine best features of long fuselage and gears.



Joe Foster turns loose California long fuselage job at finals in Finland. Unfortunately, Finnish conditions did a switch. The wind blew!

Stark's winning machine was a conventional 'Swedish' design which, to describe simply, is an orthodox slab-sided fuselage with a rather deep, narrow section. Moderately high aspect ratio wings are used with parallel chord planform and the tips only cranked to dihedral. The tail unit is of simple rectangular outline. The design in fact does not impress as anything out of the ordinary but the model, like all Swedish models, is characterized by excellent construction. In flight, Stark's model was very stable with a moderate rate of climb but a sustained motor run giving considerable height. The propeller is approximately 18 in. diameter with a fine pitch—a feature which Stark intends to alter for next year's contest—powered by 14 strands Dunlop 1/4 strip. The propeller freewheeled at the end of the power run.

Tubbs of Great Britain, who placed second, flew a fairly orthodox pylon slabside with a streamlined nose. Fuselage length was 43 in., motor 16 strands of Pirelli 1/4 strip driving an 18 in. dia. fairly high pitch propeller. Although the motor run was short—around 60 seconds—the rate of climb was high, and hence altitude gained considerable.

Freewheelers therefore placed first and second, one a geared model and the other a single skin straight-drive motor. On balance there was really very little to choose between the performance of these two. In fact, it was



George Perryman with geared model. Consensus of opinion was that consistency rates first; long fuselage—but geared!—is best '52 bet.

generally thought that Tubbs would be the eventual winner after round two, but his last flight was a relatively poor one due to a slight upset to glide trim.

As a basis for consistent flight performance, take the flights made over 200 secs. duration. Only three people achieved three flights over this mark—the winner, Lustrati (Italy) and Hofmeister (U. S. A.). Two of these were geared models incidentally. That conditions deteriorated can be shown by the fact that round one saw 17 two hundred sec. plus flights; round two 12; and round three only five. Consistency, it seems, is still the main factor—and probably even more significant now that Finland has shown that even her weather is not infallible. The 1952 contest will be flown in Sweden, which is more or less an adjacent country, and it seems that every effort will be made to carry on the method of 'night flying' if a suitable venue can be arranged.

In any overall survey of the models at the 1951 Wakefield it is still the American jobs which come first in the picture. Stark was undoubtedly a worthy winner. His was a beautifully built model, beautifully trimmed, but with nothing particularly outstanding about it to invoke further comment—except that he used gears. The American models on the other hand typified similar outstanding workmanship with

(Continued on page 47)

IT'S WHAT'S IN

THAT



TESTOR CHEMICAL  
ROCKFORD, ILLI



BACK OF THE L

*Counts...*



COMPANY  
NOIS

EL



**TESTORS**

..... **THE DOPE**

**WHAT IS SPECIALLY FORMULATED**

**FOR MODEL AIRPLANES...**

by **RUSS NICHOLS** and **CARL WHEELY**

► **SWEDEN WINS WAKEFIELD CONTEST.** S. Stark has won for Sweden the International Lord Wakefield Trophy, marking the first time it has been awarded to that country in the trophy's 16 competitions. The victory totals now stand: Great Britain—6, United States—5 (an additional U. S. victory was disqualified because of a mixup in dates), Finland —2, France—1, and Sweden—1.

Austin Hofmeister, Baltimore, Md., was tops for the United States this year. He placed fifth and Manuel Andrade, Oakland, Calif., seventh. The latest reports at the time of publication indicate that Great Britain placed second and Italy third. What we're all waiting to hear is what the weather was like and what the winning times were. (See Sweden Wins the Wakefield, elsewhere in this issue.) Our guess is that the weather was really rough and our Team members' models were built to suit typical Finnish conditions too much. Anyway, hats off to our Team for a good try!

One thing we must say is that our Wakefield Team was really sent off in style. On hand at the luncheon presented by Bill Effinger at the Wings Club in New York were Casey Jones of the Academy of Aeronautics, Bill Winter, Don McGovern, Al Lewis, Carl Wheely, William Fletcher, Bob Hatschek and, of course, the Team. Casey Jones' short talk was well put, remembering the thought of the late Lord Wakefield's original aim to encourage the design and development of miniature rubber-powered aircraft (the original rules specified any power-Editor) and, most important of all, to support a sporting activity which would bring together official representatives from the youth of all nations.

Let's not forget Jim Walker. Without his aid our Team could not have participated in person as it did.

**LIABILITY INSURANCE.** Just what AMA Chartered Clubs and Chapters have been waiting for in the way of liability insurance coverage for all the club's activities is the new club policy which the AMA helped in working out. The coverage seems so complete and the premiums so reasonable that every club will want to have this protection. Already available in most states, this protection is provided for all club activities on the insured premises or elsewhere and the ownership, maintenance or use of any premises (meaning building or land) in connection with the club program. The following questions asked of the insurance agent, and his answers, will give you a better insight to the advantage of the club's having third-party liability insurance:

1. What protection does Liability Insurance afford?

Answer: Liability Insurance protects against claims for bodily injury and property damage up to the policy limit arising from club or chapter activities. It therefore protects the financial assets of the club or chapter.

2. Can the individual members of an unincorporated club or chapter be used if an accident (Continued on page 52)



Prize winning Howard in an eastern Plymouth eliminations takes off in the old World's Fair parking lot. Helper releases for the builder Henry Nelson.



## official news

**Wakefield finals • New liability insurance plan • Summary of new national records • Inter-club competition • Complete contest calendar dated up to January**

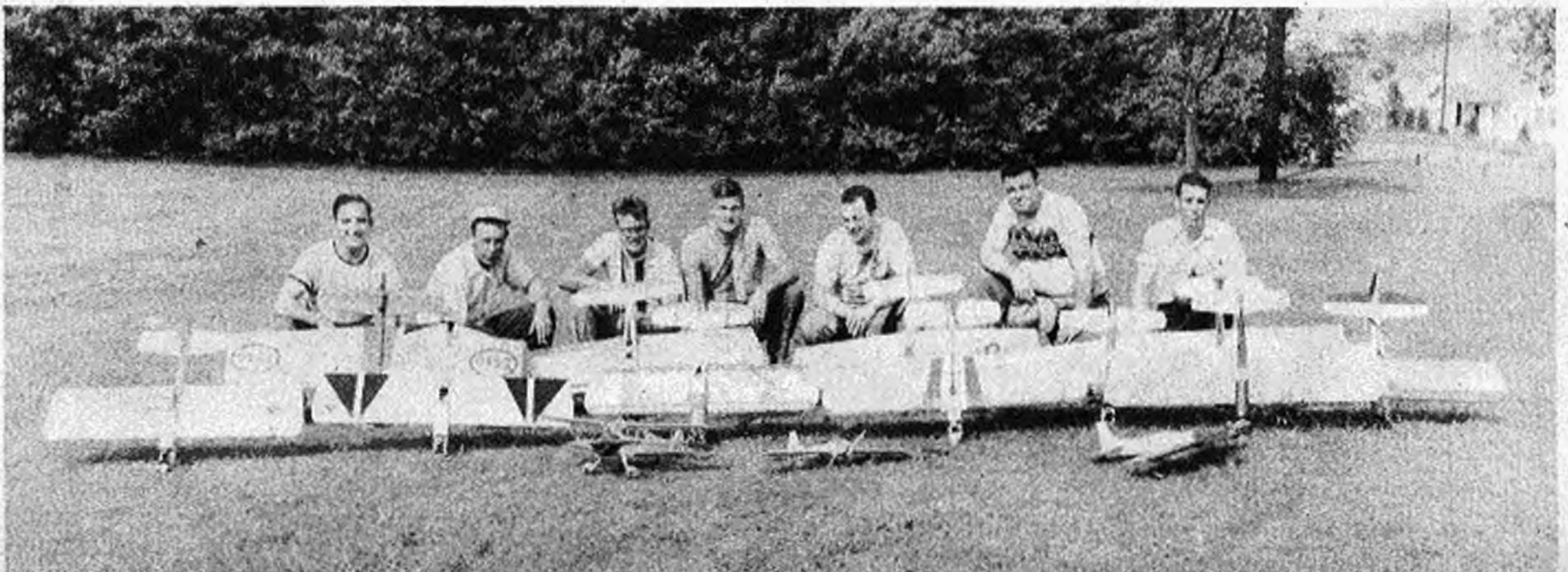

Morristown, Tenn., Flying Club: L. to R.—James Grotz, Dorsey Williams, J. T. Noe, David Noe, Bill Duncan, Bill McCune, Ralph Wright. Stunt's the thing.

*"Spitfire" does it AGAIN!*

FOR FUN, THRILLS, EXCITEMENT!

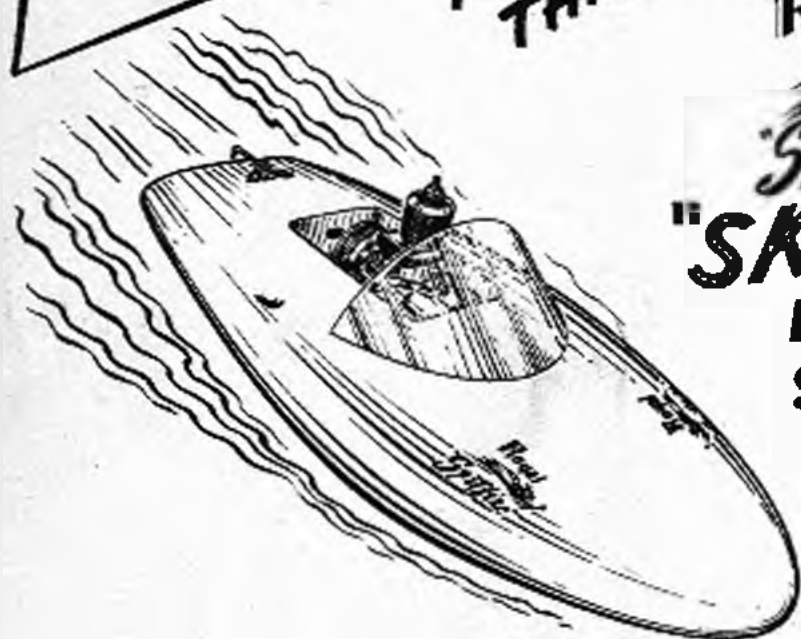

Royal Spitfire "SKIM'R"

MINIATURE SEED BOAT

Powered by the Royal Spitfire .065 Engine ONLY

\$9.95

COMPLETELY ASSEMBLED

Completely shaped and painted hard wood hull. 13" of dynamite ready to skim the surface.



Spitzy NITROMIC GLOW FUEL "the Supreme-Power Glow-Fuel"

ONLY 85¢

FULL PINT

BE A WINNER

MODELERS When you build, build a WINNER!

HERE'S YOUR CHANCE

ENTER BOTH CONTESTS TODAY!

Don't Forget! Spitfire

CONTEST--LAST 30 DAYS TO WIN \$500.00!

Nothing to buy. ENTER NOW! See your favorite "Spitfire" Dealer for simple rules and entry blank. Contest closes Sept. 30, 1951.

FREE DIVIDEND CARDS

No blanks. Not a contest. No drawing. No judging. Gift values to \$25.00. Cash and Merchandise.

Always the FIRST to bring the modeler NEW and BETTER PRODUCTS, "SPITFIRE" is happy to announce it is co-sponsoring a NEW, GREAT FLYING MODELS CONTEST.

ALL AMERICAN

*Flying Models*

CONTEST

OVER \$3600.00 IN PRIZES

\$500.00 CASH FIRST PRIZE

\$250.00 CASH SECOND PRIZE

\$100.00 CASH THIRD PRIZE

Over 300 Additional Prizes!

Get FULL INFORMATION at your favorite dealer

Co-sponsored by SPITFIRE . . .

MEL ANDERSON Manufacturing Co. 1819 THIRD AVE., LOS ANGELES, CALIF.

# gee bee

The hottest racer of its day, the glamorous Gee Bee Super Sportster is here converted into a successful control-liner by one of the country's top hands. Brother, don't ask for more!



by LES McBRAYER

The amazing realism of the miniature racer will make scale fans wet their lips. It's more than a looker, too, because performance is on the ball.

► One of the most famous of all racing airplanes, the Gee Bee with its short, stubby design makes an unusually attractive control-line model. Although a little harder to construct than some models, the builder will be rewarded with a smooth, easy flying model which can be used for Scale or Team Racing contests. The Gee Bee will attract great attention wherever it is flown.

Gee Bee NR-77V was built by the Granville Brothers in Springfield, Mass. It was powered with a Pratt & Whitney Wasp Jr. engine developing 525 horsepower. The unusual design immediately earned it such nicknames as the *Flying Silo* and *Flying Milk Bottle*. Lowell Bayles flew the Gee Bee in the 1931 National Air Races at Cleveland, Ohio. Flying in the Shell speed dashes he averaged 267 mph. This

qualified the Gee Bee for the 100 mile Thompson Trophy Race. Flying a beautiful race, Bayles won the Thompson at an average speed of 236 mph, breaking the old record by about 35 mph.

Late in November 1931 Bayles flew his stubby yellow and black racer, now equipped with a larger engine, in an attempt to set a new world's landplane record. He was unofficially clocked at 307 mph but timing difficulties prevented a new record.

On December 5, 1931 while making another record attempt at a speed of about 325 mph the Gee Bee suddenly disintegrated in mid-air and hit the ground in a ball of fire. Lowell Bayles had no possible chance to escape. So in the space of a few short months (Continued on page 36)

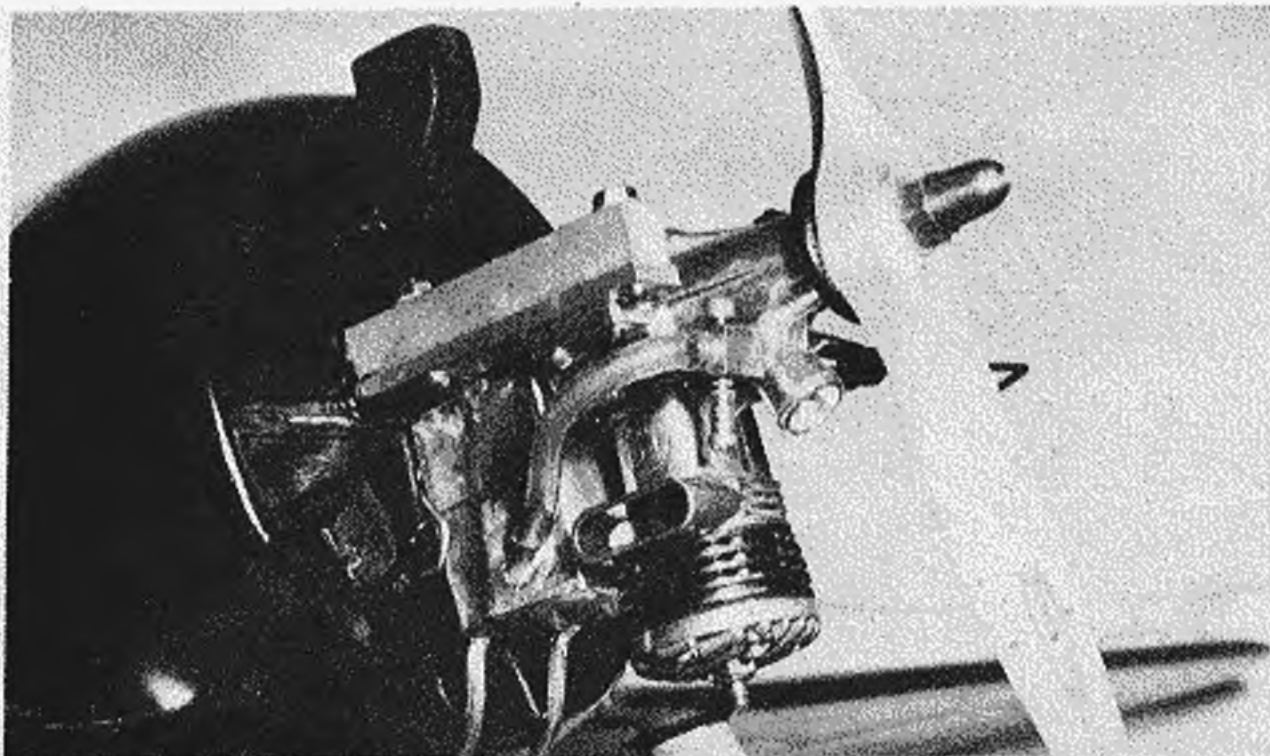

Close-up of the engine installation shows the inverted K & B .19, the tank, line, and the vents. A good flier on the K & B .19, the Super Sportster does still better with the larger McCoy .29.



The author with original model. Les McBayer is one of the original members of the F.A.S.T. club.

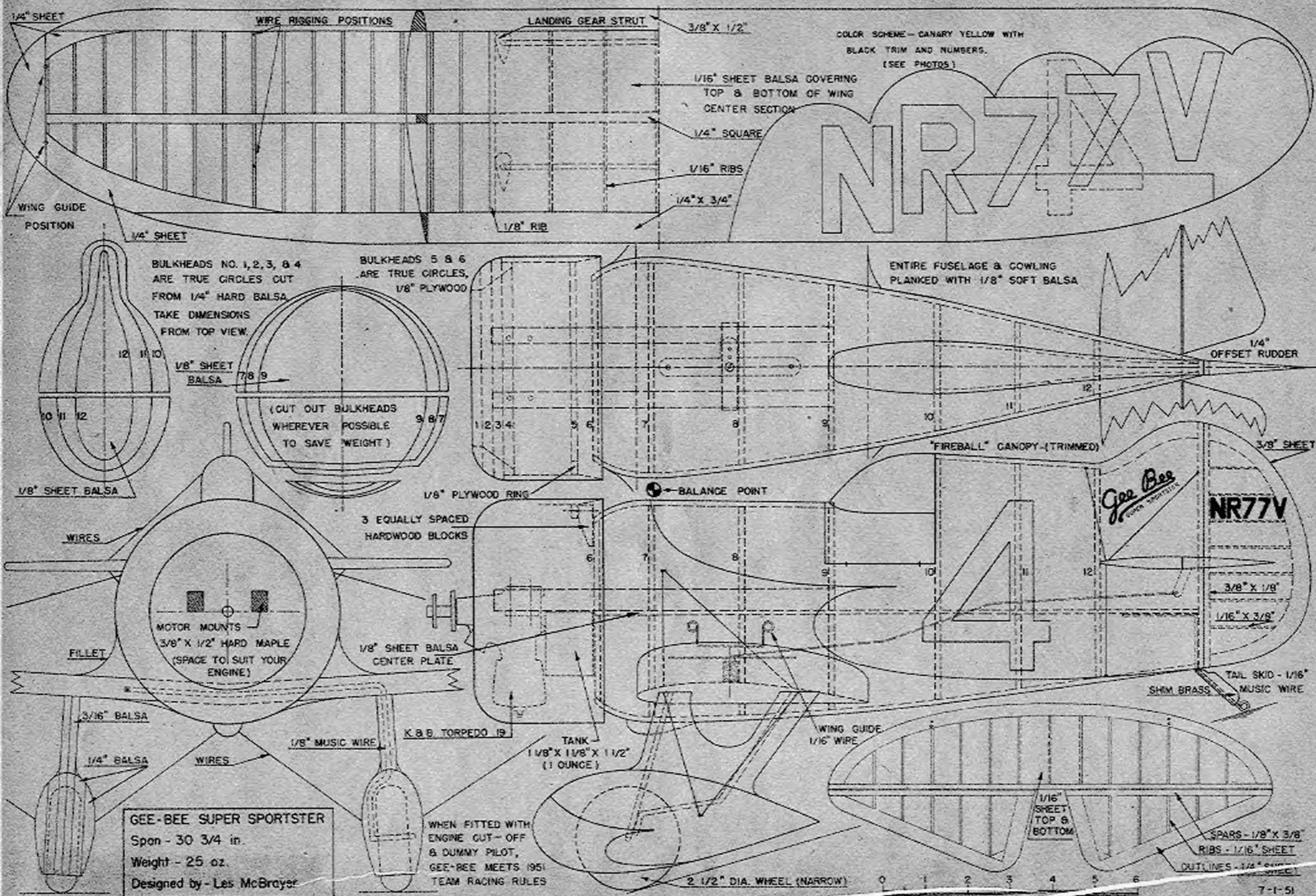

**GEE-BEE SUPER SPORTSTER**  
 Span - 30 3/4 in.  
 Weight - 25 oz.  
 Designed by - Les McBrayer

WHEN FITTED WITH  
 ENGINE CUT-OFF  
 & DUMMY PILOT,  
 GEE-BEE MEETS 1951  
 TEAM RACING RULES

# K & B TORPEDO

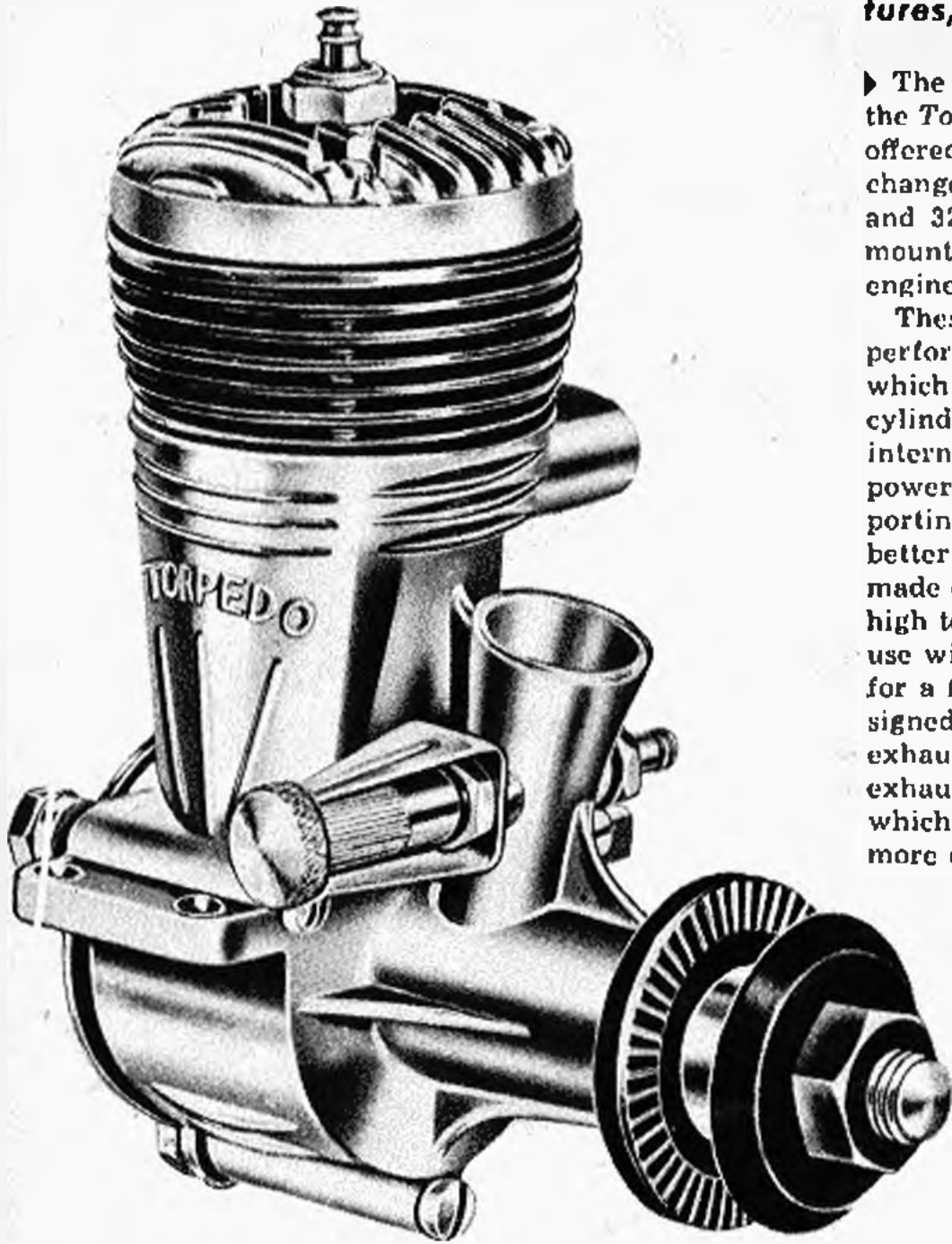

*Increased intake porting, light piston, gives new .29 and .32 a big boost in power. Lots of new features, but parts interchangeable with old engines.*

► The newly redesigned K & B 29 and 32 engines now make the *Torpedo* family one of the most complete lines of engines offered to the modelers today. Though there are numerous changes, the new engines will not obsolete the old style 29 and 32's as all parts still remain interchangeable. Also, all mounting lugs remain the same, therefore making the new engine interchangeable with the old.

These engines are designed and engineered to emphasize performance and dependability. The following are the changes which give the 29 and 32 the new look with new power. The cylinder head is not only thicker and more streamlined, but internally is redesigned for more even combustion. New power is gained from a 25% increase in the cylinder's intake porting along with a new light weight Meehanite piston for better engine balance and less vibration. The wrist pin is made of aircraft steel tubing. The crankshaft is now made of high tensil strength stress-proof steel to stand up under hard use with today's hot fuels. There is a new type needle valve for a finer, more positive setting to go with the larger redesigned venturi. With new eye appeal we find a new type exhaust with 35% more area for less back pressure and greater exhaust scavenging; also, a new crankcase with a big bypass which has greatly increased power by giving the engine a more efficient transfer of fuels.

## ENGINE REVIEW

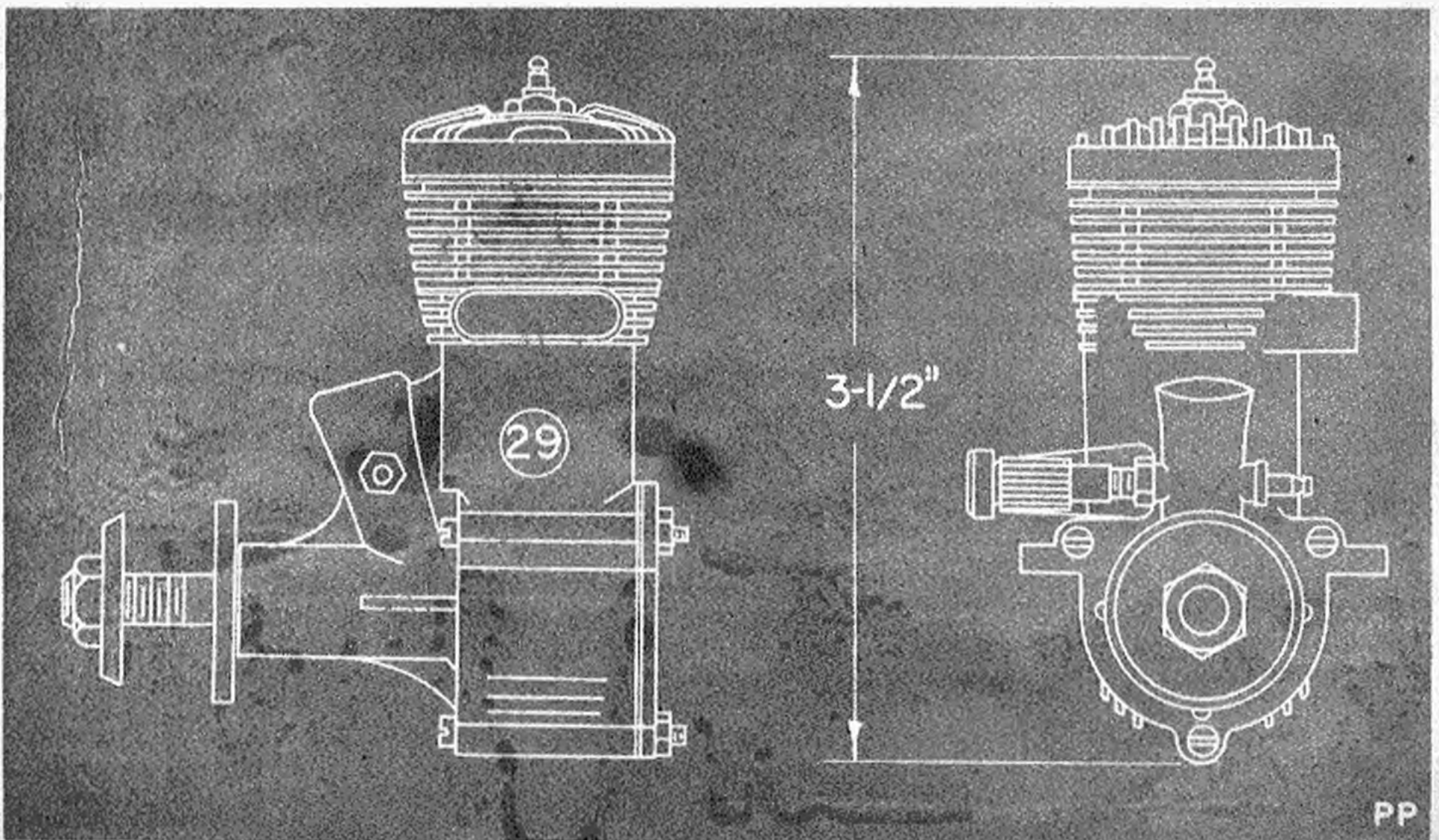

# Flash!

'51 NATIONALS  
DALLAS, TEXAS

# BARNSTORMER WINS AGAIN!

*Lou Andrews* 1950 NATIONAL STUNT CHAMPION  
**BARNSTORMER**

Wing Span 47 in. Weight approx. 28 oz.  
Wing area 470 sq. in. Speed 60 to 75 M.P.H.  
Length 30 1/2 in. Engine 22 to .33 disp.

Here is the sensational performance record -- SENIOR STUNT EVENT won by Burr Ferguson with 390 1/2 points. OPEN STUNT EVENT won by Lou Andrews with 418 points. Lou won the National Stunt Championship (the highest award) and with it the coveted Jim Walker Trophy.



\$5.95

CLASS 1/2A CONTROL LINE STUNT MODEL  
**BABY BARNSTORMER**

A JUNIOR VERSION OF THE 1950 NATIONAL STUNT CHAMPION TRIXTER BARNSTORMER

FINE  
**TRIXTER**  
MODELS

DESIGNED BY LOU ANDREWS



Wing Span 33 1/2 in.  
Wing Area 118 sq. in.  
Length 25 1/2 in.  
Weight approx. 4 1/2 oz.  
Engines .033 to .045 disp.

\$2.95

**GULLOW'S** Sensational  
**DIE-CUT Balsa**  
**SHELF MODEL AIRPLANE KITS**

18 EASY TO BUILD SCALE MODELS  
ALL MILITARY - INCLUDING 10 JET JOBS  
EASY ASSEMBLY - NO DIFFICULT CARVING



BOYS! HERE ARE 18 OF THE EASIEST BUILDING SCALE MODELS EVER OFFERED. EACH ONE IS A DUPLICATE IN MINIATURE OF A WELL KNOWN FIGHTER. WITH GULLOW'S DIE-CUT SOLID, YOU DON'T HAVE TO SPEND LONG HOURS CARVING BLOCKS TO SHAPE - JUST ASSEMBLE THE DIE-CUT PARTS IN A JIPPIE AND ROLLO UP THE EDGES WITH A KNIFE OR SANDPAPER. ALL YOU NEED BESIDE A KIT IS A TUBE OF MODEL AIRPLANE CEMENT - THEN YOU ARE SET FOR AN EVENING OF FUN. ONCE YOU HAVE STARTED, YOU'LL WANT TO BUILD THE WHOLE ASSORTMENT.



*Boys!* SEE YOUR LOCAL DEALER FOR GULLOW KITS - IF NOT AVAILABLE, SEND DIRECT TO FACTORY, ADDING 15¢ TO ALL MAIL ORDERS. **DEALERS! SEND FOR LATEST CATALOG AND PRICE LIST**

**GULLOW'S** FLIGHT TESTED **1.00** AIR YOUTH TODAY.  
**FLYING MODEL** AIR LEADERS TOMORROW  
*Airplane* Construction Sets

FULL SIZE PLAN • ILLUSTRATED INSTRUCTIONS • AMPLE BUILDING MATERIALS



*Special* Large wing span flying models with the new time saving die-cut balsa formers, ribs, tail outlines, wing tips, and landing struts.  
**RAZOR SHARP DIE CUT Balsa PARTS**  
PLASTIC PROPELLER NO CUTTING—JUST PRESS OUT AS NEEDED!

**GULLOW'S** REALISTIC SCALE AIRPLANE **50¢**  
**FLYING MODEL** EACH  
Construction Sets

★ FLIGHT TESTED DESIGN  
★ ILLUSTRATED DIRECTIONS

**SPECIAL VALUES IN EACH KIT**

RAZOR SHARP DIE-CUT Balsa PARTS  
NO CUTTING—JUST PRESS OUT AS NEEDED!  
SHAPED NOSE BLOCK  
PLASTIC PROPELLER

CESSNA AERONCA CHAMPION  
VOUGHT CORSAIR SPITFIRE  
BRITISH SE-5 WACO CUSTOM  
MONOCOQUE HAWKER HURRICANE

The die-cut parts in these kits make it easier for the child builder to complete his airplane. Full size plans, step-by-step illustrated instructions and patterns for stiff paper and tissue covering are also included.

manufactured by **PAUL K. GULLOW** Wakefield, Mass.



**NOW—CONTROL  
YOUR MODELS  
BY RADIO!**



**This New Book  
SHOWS YOU HOW**

112 Pages

114 Illustrations

**Only \$1.00**

Radio Control means more realism in your hobby—more fun for you! **MODEL CONTROL BY RADIO** by Edward L. Safford, Jr. is the first and only complete book to show you how to apply the principles of radio control to your hobby.

#### FOR BEGINNER AND EXPERT

It starts right at the beginning—tells you what radio control is and why and how it works. It gives you all the theory behind coding, transmission systems, receivers, power control units and all the other elements which go into a radio control system. Then, it tells you how to make not only separate units, but complete systems as well. Every important step is illustrated with explanatory photos and diagrams. The author, Edward L. Safford, Jr., already well known to Model Airplane News readers, is tops in this field. An instructor in guided missile electronics at Fort Bliss, Texas, he has worked on several government radio control projects. Order your copy of **MODEL CONTROL BY RADIO** today and double the enjoyment you can get from your hobby.

**DEALER INQUIRIES INVITED**

**RADCRAFT PUBLICATIONS, INC.**

**RADCRAFT PUBLICATIONS, INC., Dept. M  
25 West Broadway  
New York 7, N. Y.**

My remittance for \$1.00 is enclosed. Please send me postpaid a copy of **MODEL CONTROL BY RADIO**.

Name.....

Street.....

City..... Zone..... State.....

## Scrap Box

(Continued from page 5)

abolished completely to prevent the "pirate modeler" from ruining a swell sport and hobby. Eliminate the possibility of three people combining their talents to walk off with the National Champion Trophy. Opinions and facts are wanted from both sides. Another opinion is voiced—"Sure, some builders never fly. Dizziness, age, and a host of other things may prevent an ardent modeler from getting the thrill of seeing his ship win." And "How about one swell trophy for the winning high point team entry and that's it," says another. All points well presented and taken fellows. We agree, the National Champ who builds the ships and flies the events himself deserves the title.

The radio boys are organizing out west. Plenty of ships are getting in the air and a bunch more are in the process of being built. A get-together meeting was held at an abandoned airstrip near Santa Ana, California to start the organization rolling. Everyone got so wrapped up in flying that not much was accomplished. Designs and equipment were closely scrutinized and a darned interesting "bull session" developed. Yours truly is even finding out where all the wires are supposed to go and why. Colby Evelt had his modified Ehling designed Paragon out for a session. The ship was designed originally in 1942. Colby's ship has the two channel rig set-up and also sports a new British receiver. The ship has elevator, rudder, engine, and a bomb release control set-up. The Fox .35 carries two needle valves for engine control adjustment with a relay type K & B shut-off. The shut-off is much the same as Harold Bonner's. This ship is the same one Evelt flew at the Nationals. Bill Butler was out with his two ships and was doing a nice job of flying until someone decided to try his transmitter while Butler was in the air and on the same frequency. The ship wasn't damaged too much but a few faces were very red.

Two newcomers to R.C., the McHuen brothers, made some of the best flights of the day with their *Good News*. This little job carried on Arden .009 for power and sported the very popular Aero-Trol radio. We saw the first flight these boys ever made, and it was very sharp. Everything was right out of the book and worked perfectly. These lads believe in small ships and rightly so. Judging from all appearances and performances.

Our greatest trouble, when making the first flight, was reversing rudder positions when the ship was coming toward us. E. J. Brown gave us a solid tip for the beginner. When testing a new ship, let it get up high enough before trying a turn. Of course, be ready to correct your flight attitude as soon as the ship is airborne just in case. Have your control box in the right position so you will know what control is coming up first. For gosh sakes, leave the engine a bit rich on that first flight and don't put too much fuel in the tank. We had a four minute screaming run on our first flight and got about 1500 feet in the air in short order. Would have sold the crate and equipment cheap about that time but all ended well and we're still flying the old Bug.

We were interested in a discussion about the KD2R3 Drones (target ships) and the type of equipment they use. These jobs carry a 72 h.p. engine. The KD2G2 carries the pulse jet (110 lbs. static thrust). Both ships carry the RPR1 receiver. Transmitter is an RC36A, and is a one frequency job as is the receiver. The transmitter put out five different tone signals which the receiver picks up one at a time. Each of the five tubes in the receiver respond to certain tone (cycles) signals which energize their circuit. This in turn operates its particular relay. The relays are hooked to servos which operate the various controls: right, left, up, down, and neutral. When no tone is sent out, the parachute is dropped out and the ship settles down safely to earth or sea which ever the case may be. All radio equipment is in a watertight compartment. Flying one of these 200 m.p.h. hot rods is

an art. The Drone will do anything a big ship will do and probably much faster due to size. The cat and mouse game goes on—target ship vs. firepower. The enemy of the Drone is anything from a five incher on down. These ships have a 138" span, 147" fuselage, 50" stab, and the prop is about 44" in diameter. Gassed loaded weight is approximately 320 lbs.; air weight 150 lbs. The ships are launched from a compressed air catapult.

Toshihisa Watanabe gave us a rundown on some of the model activities being held in Japan. We were surprised at some of the times turned in at Matsudo (former aerodrome). Sponsors of the meet were the Model Airplane Federation of Japan and the Maimichi Press. The contest was held under adverse weather conditions with a 6-7 meters per second of wind blowing. Rain also made its appearance but the meet went on. At the Fourth All Japan Model Airplane Contest the following times were turned in: Hiroshi Sawada turned 104.40 with an O. S. 29 in B Speed, Kanejira Kondo turned 133.33 with a K.O. 60, and Kikuo Takochi burned the circle with his O.S. jet to the tune of 137.40 m.p.h. We've had the opportunity of seeing some of the Japanese made engines and they seem to be made very well. The Plymouth Motor Corporation through the Anzen Automobile Company, supported a Plymouth eliminations to chose winners to make the "big meet" in the states.

Jetex is a favorite with Bill Bysbyn of Brooklyn. Bill's efforts have been turned toward the scale jobs, his latest being an Heinkel He-162. This ship is powered with a Jetex 100. Span 17-1/2", length 23". It deviates from scale in increased wingspan and a bit more stab area. It was found that the cowl on this ship caused too much internal turbulence so the ship was flown without it. Bill has drawn up about every type of fighter (jet powered) in the books and is still going strong.

The Wakefield committee did a bang-up job of organizing the eliminations and finals. Although the United States didn't win at the "big" meet, at least all hands know that an all-out effort was made to get the best ships to Finland. To everyone concerned, from the fellows who got out and flew to the committees that did all the leg work and tabulating, we sincerely wish to say "well done." Hope to see that "mug" come to the good old U. S. next year.

—by JIM SAFTIG

## The Gee Bee

(Continued from page 32)

the Gee Bee left its marks in aviation history. It undoubtedly was the fastest landplane of the day even though it never held the official record. Other Gee Bees followed from the Granville Brothers workshop and these tricky but fast racers were always a threat in any race they entered.

**WING:** Cut 36 wing ribs from 1/16" balsa and two from 1/8" balsa. The eight center section ribs are cut down 1/16" top and bottom to allow for the sheet covering. From 1/4" balsa cut out the wingtip parts. Assemble each wing panel separately. Pin leading edge, spar, and trailing edge to a flat board, then cement in the ribs. Add the wingtip parts and cover the upper center section with 1/16" sheet balsa. When dry, sand the panels to final shape. Cement the wing panels together, blocking both wingtips to a height of one inch to form correct dihedral angle. Cut a 3/8" x 1/2" x 2" block to fit the center section and cement in place to form the control plate mount. Leave the center section bottom uncovered. Bend the wingtip guide from music wire and cement in position. Cement a 3/4 ounce lead weight in the right tip.

**TAIL SURFACES:** Cut stabilizer and elevator outlines from 1/4" balsa, spars from 1/8" x 3/8" hard balsa, and ribs from 1/16" balsa. Cement parts together and sand to streamline shape. Insert the 1/16" sheet covering flush with the center section as shown. Install

your favorite type of hinges and control horn. Note that the control horn is angled forward to provide sufficient clearance from the rudder post.

Cut rudder outline from 3/8" balsa, spar from 1/8" x 3/8" hard balsa, and ribs from 1/16" sheet balsa. Cement parts together and sand to final shape.

**LANDING GEAR:** Bend the two wire landing gear struts to the shapes shown in the front and side views. The use of a vise and a heavy hammer will help greatly in forming the heavy 1/8" dia. music wire to shape. This forming should be done slowly and carefully to insure proper alignment of the gear. The joint where the two struts meet should be wrapped with copper wire and well soldered. Place wheels in position with a washer soldered on each side. Check to be sure that the wheels can not rub against the struts.

Each of the wheel pants is made in a layer of four 1/4" sheets and two 3/16" sheets. Cut these parts out and cement together to form two right halves and two left halves. Temporarily tack cement the halves together, then carve and sand the wheel pants and struts to final shape. Split apart and hollow out to clear the wheels and the wire struts.

**FUSELAGE:** Due to the Gee Bee's short nose moment arm, the rear end of the fuselage should be kept as light as possible by cutting away the bulkheads and the centerplate wherever possible. From 1/8" sheet balsa cut the center plate of the fuselage to the size shown in the top view. It will be necessary to make this in two halves, cemented together down the center line. Mark the bulkhead positions on both sides of the center plate. Cut out upper and lower bulkheads number six to twelve from 1/8" balsa. Pin the center plate to a board with the rear end of the plate overhanging the edge of the board. Cement the lower halves of the bulkheads to the centerplate taking care that all the bulkheads are vertical. Cement the 1/8" x 3/8" rudder post in place at the end of the centerplate. Bend tail skid to shape and cement in place against the centerplate and rudder post. Later the tail skid should be sewed to the centerplate with thread. Start

planking the fuselage with 1/8" x 3/8" soft balsa strips, beginning at the center plate and working both sides evenly until fuselage is covered down to the wing position. Now while the fuselage is still pinned down to the board, cement the wing in position, taking care that the wingtips are level with the board and that the flat bottom of the wing is parallel with the centerplate.

Install the landing gear in the center section of the wing. Cut away the ribs where necessary to make room for the gear. When the gear is fitted into position and properly lined up, apply two liberal coats of cement to all possible joints. Cover the wing center section with 1/16" sheet and add the remaining pieces of bulkheads seven, eight and nine. Remove the entire assembly from the board and install the control plate with a 4-40 machine screw through the mounting plate and the wing. Finish planking the bottom of the fuselage. Securely cement the balsa wheel pants in place against the landing gear wires and the wing.

Cement the motor mounts securely in position on the center plate, then cement the upper bulkheads in place. Plank the sides of the fuselage up to the level of the stabilizer. Mount the stabilizer in place and hook up the control push rod and the load out wires. If an engine cut-off hook is to be used, mount an extra control push rod extending forward through the front bulkheads and into the cowl section. If a dummy pilot is desired, cement in a cockpit floor of 1/16" sheet balsa. Instrument panel and other cockpit details at this time. Set in the top portion of the fin cut from 3/8" balsa and finish planking the fuselage. Cut out planking to form the cockpit. Cement the rudder in place with a 1/4" offset to the right.

**COWLING:** Cut bulkheads one, two, three, and four from 1/4" sheet, cement together with the grains running in different directions for added strength. Carve and sand to shape. Cut plywood ring number five from 1/8" material. Start assembly of the cowl by using four planking strips of proper length cemented at equal spaces around bulkheads four and five. Check to be sure cowl

is lined up properly, then when dry, add the rest of the cowl planking strips. Carve three small maple blocks to shape for cowl mounting blocks. Drill holes through the plywood ring and the blocks, and using 4-40 machine screws and nuts, bolt the blocks to the cowl. Now apply cement to the rear faces of the blocks and pin cowl in place against the front end of the fuselage until dry.

**ENGINE & TANK:** The original model was powered with a K & B Torpedo .19 which gave very satisfactory performance, having a speed of about 75 mph using a 10-8 Power Prop. Any .29 engine or powerful .19 engine may be used to power the Gee Bee. In order to mount engines having rear rotary valves it may be necessary to cut away part of bulkhead number six for additional room. Make up a one ounce tank and mount it on the motor mounts with the fill and vent tubes coming down and out the space between the cowl and the fuselage. Cut holes in the cowl for access to the glow plug and for the needle valve. No exhaust hole is needed if the interior of the cowl is cleaned after each flight to prevent possible fires.

**FINISHING:** The original model was built entirely with fuel-proof materials: Aero-Gloss cement and plastic balsa, Butyrate dope, and Sta colored dupes. Sand entire model until it is smooth and then cover all parts, including the fuselage and cowl, with silk. Give the model several coats of Butyrate dope until the pores in the silk are filled. The large fillet between wing and fuselage may be easily formed by using a combination of silk and a surfacing putty. First make as good a fillet as possible using wet silk and then after it has been doped, smooth out the low spots, etc. with applications of a putty such as Aero-Gloss Plastic Balsa. This type of fillet can be made very light and very smooth.

When model has been sanded, doped and sanded to a good surface, paint entire ship with yellow Sta. Three brushed coats should be sufficient. With a soft pencil, draw the scallop design on wing and fuselage. Mask off the design with narrow masking tape, and paint with black Sta. Use black decals for all

## Now You can FLY a Model Helicopter!

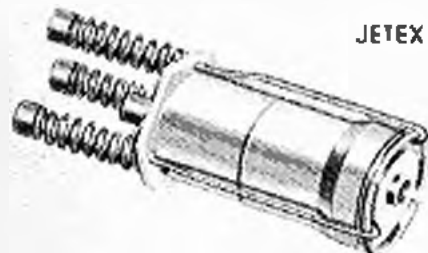

JETEX - 100

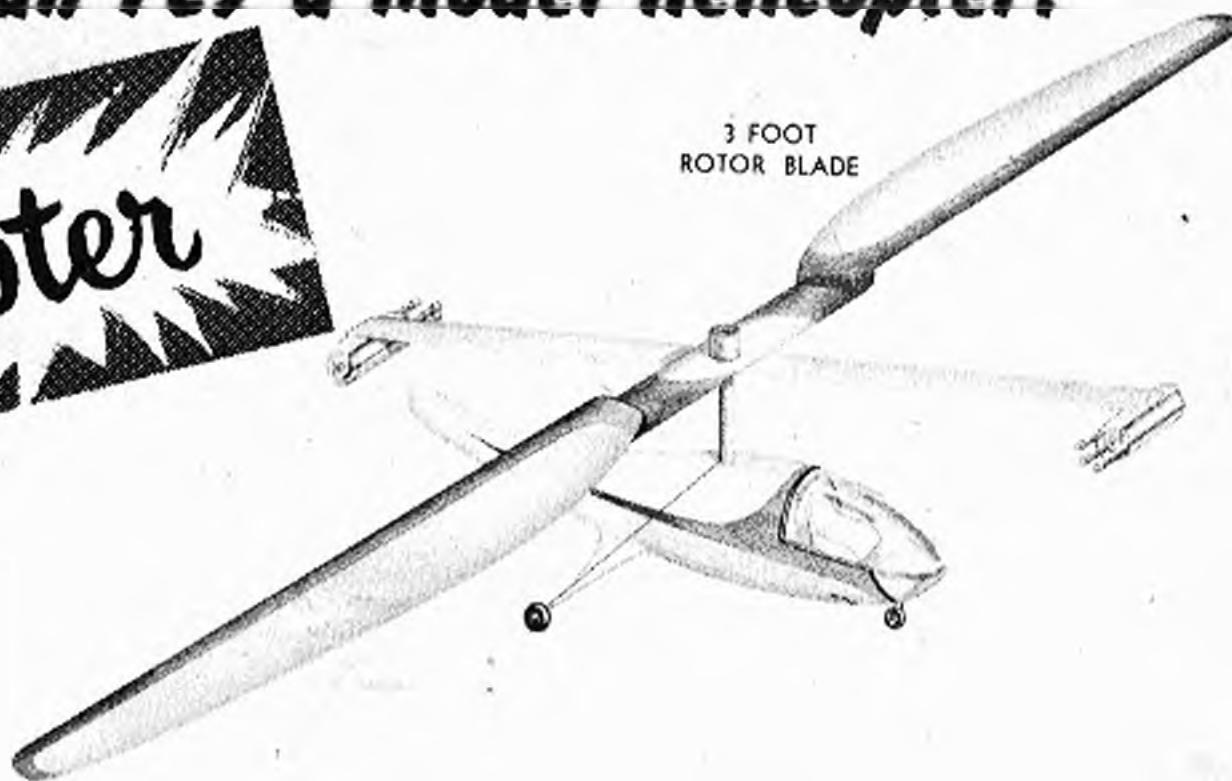

3 FOOT ROTOR BLADE

Use the amazing Jetex Jet Engines for reliable, effective power for model planes, boats and cars.

PRICES including instructions, fuel, accessories, mounting clips

# 50 wing spans 12" - 20"	\$1.95
#100 " " 18" - 30"	\$4.50
#200 " " 24" - 36"	\$5.95
#350 " " 36" - 54"	\$8.95

Additional fuel supply for each size:  
66c - 75c - 95c - \$1.00 respectively.

New flying thrills for you with a real FLYING model helicopter! Duplicates the flight of an actual helicopter... twin-jet power takes it to a height of 100 feet or more... self-adjusting rotors bring it to a perfect landing

Kit includes all parts, die-cut balsa... full scale plans, rotor hinges and engine mounting clips... materials for covering fuselage and forming landing gear.

Kit includes one JETEX #100 engine

Complete Price \$3.75

See your Dealer or write: AMERICAN TELASCO, Ltd., 55 W. 42nd St., New York 18, N. Y.

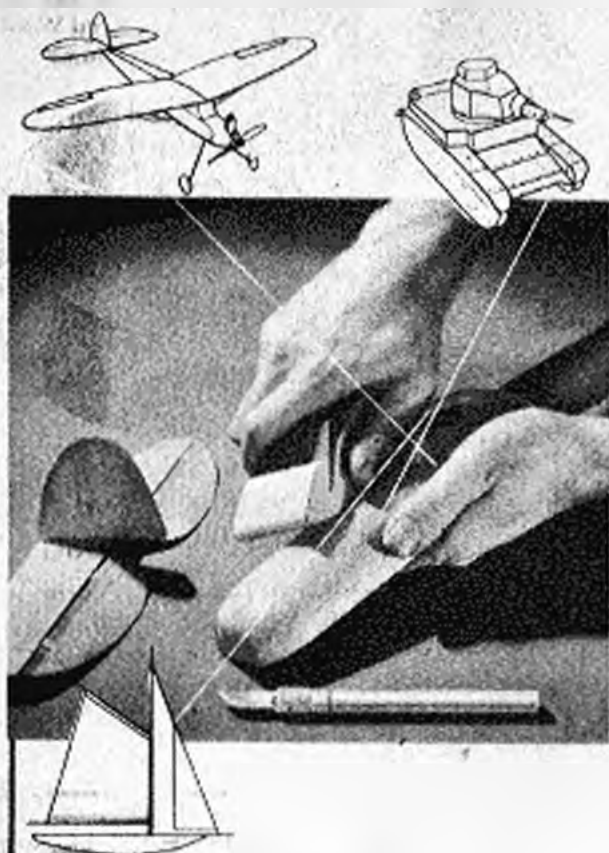

## make your **HANDS** **MORE CREATIVE** with **X-acto Knives and Tools**

X-acto precision knives and tools give untrained hands the confidence that makes them creative.

X-acto originates attractive handicraft projects... goals easily accomplished. The finished product gives you the pride of achievement that comes only with doing something well with your hands.

For their hobbies... boat whittling, model airplanes, woodcarving, leathercraft, model railroads or any other handicraft... master craftsmen and hobbyists select "designed-for-the-job" X-acto knives, tools and handicraft kits. X-acto offers the complete line of handicraft knives, interchangeable blades, tools and attractive kits.

From 25¢ to \$30.—at dealers everywhere



No. 86—X-ACTO HOBBY CHEST—\$12.00

Send 15¢ to cover postage for our new illustrated 28-page Catalog.



**x-acto**®

**X-acto Crescent Products Co., Inc.**  
440 Fourth Avenue, New York 16, New York

numbers and letters. Strip some black Trim-Film to 1/16" widths and mark the aileron, rudder and cockpit lines. Gee Bee is put on the film with a small brush and black Sta. The small words Super Sportster are put on with India Ink and a pen. If the cowl markings are desired, they can be painted on with white Sta. These markings consist of a group of three buildings with the words City of Springfield and Powered by P & W Wasp Jr. See photos and details. Use a thin coating of clear Sta (sprayed or very carefully brushed) over the letters and decals to seal them down. Cement hubble in place. If flying and brace wires are desired, use .000 dia. music wire and thread wires through the model as indicated on the plans.

**FLYING:** If your Gee Bee is to be a stable and smooth flying model, it is essential that the balance point is as marked on the plans—3/8" back from the leading edge. Add weights to the nose or tail if required. Be sure all surfaces are at zero degrees incidence. Make certain that the rudder is offset 1/4" to the outside of the circle. Be sure that the wheels turn in the pants freely and that the model rolls straight on the ground.

Due to the Gee Bee's short fuselage and the high angle of attack when sitting on the ground, it is necessary to hold the controls in the full "up" position at the beginning of take off to prevent a nose-over. As soon as the model starts to roll and gain speed, neutralize the controls and let the Gee Bee take itself off. This method will give the long, low take off so necessary for team racing. Gee Bee will be smooth, yet responsive in the air and will have a good glide after the motor quits. However, since the landing gear is completely rigid, it is best to make smooth wheel landings. In other words don't stall it in, but fly it right down to the ground and "grease it on" like a speed model. Like most models with wheel pants, Gee Bee should be flown on asphalt or hard dirt fields.

### BILL OF MATERIALS:

- 2—1/16" x 3" x 30" Balsa Sheet.
- 2—1/8" x 3" x 30" Balsa Sheet.
- 1—3/16" x 3" x 30" Balsa Sheet.
- 3—1/4" x 3" x 30" Balsa Sheet.
- 1—3/8" x 3" x 12" Balsa Sheet.
- 1—1/8" x 6" x 6" Plywood.
- 2—3/8" x 1/2" x 12" Hard Maple.
- 24—1/8" x 3/8" x 38" Soft Balsa.
- 1—1/8" x 3/8" x 38" Hard Balsa.
- 1—1/4" x 1/4" x 38" Hard Balsa.
- 1—1/4" x 3/4" x 36" Trailing Edge Balsa.
- 1—1/4" x 1/2" x 38" Hard Balsa.
- 1—1/16" x Dia. Music Wire 36" length.
- 1—1/8" Dia. Music Wire 36" length.
- 1—"Fireball" Hubble Canopy.
- 1—Pair 2-1/2" Narrow Wheels.
- 1—Bellcrank and Control Horn.
- 1—Square Yard Silk Covering.
- Machine screws, liquids, decals.

## Fokker E-1

(Continued from page 20)

momentous conclusion: you couldn't very well fly a plane and shoot a gun accurately at the same time unless the gun was attached to the airplane. On the ground, Garros bolted the Lebel rifle on top of the cowling in front of him, pointing forward. Where the line of fire cut through the propeller arc, he boldly attached some wedge-shaped steel plates to each blade. Enough bullets, he thought, would get through to do some damage. About six out of ten did get through—enough to knock down a couple of German planes.

This hit and miss proposition had one drawback—the bullets constantly pounding the propeller wedges put unusual stresses on the propeller which Garros cheerfully guessed might shatter the prop. That's exactly what happened to Garros. He was forced down behind the German lines one day through prop failure and made prisoner.

Anthony Fokker shortly was called in by German authorities to see Garros' Morane, and was asked to see if the shielded propeller idea could be improved on and put to use for Germany. A practical mechanic, Fokker immediately saw that the solution to the problem was not in protecting the prop from harm by the bullets, but lay in

a method of causing the gun to fire only when the prop blades were out of the line of fire.

Fokker's system of cams and push-rods, by which the propeller was made to fire the gun, was attached to a single-seat monoplane scout plane he had built for the German Air Force. Subsequent tests proved the synchronizing mechanism completely workable and thus was the means for modern air-warfare born.

The first Fokker E-1 was turned over to young Oswald Boelcke, a G. A. F. Lieutenant and former school teacher. On his third flight over the lines, Boelcke succeeded in bringing down a French plane. The Germans enthusiastically ordered as many Fokkers as possible, fitted with guns and synchronizing gear. The latter were hand-made by Fokker. A few days later Max Immelmann was turned loose in the second E-1 and obtained immediate results. A month later a half-dozen additional E-1s were in action, taking a terrible toll of nearly every Allied plane they met in flight.

The advantage was on the side of the German pilots. They simply approached unsuspecting Allied planes from the rear, poured out a burst, and down they came. E-1 pilots were forbidden to fly over the Allied lines in order to keep the synchronized gun from falling into enemy hands. The toll these stinging little E-1s wrought was terrific. For nearly five months, the Germans had superiority in the air and Allied losses mounted.

But one foggy morning a Fokker E-II—an improved type—landed intact on a French airfield and the secret of the gun was out. The German pilot simply had become lost in the soup.

Before the Fokker monoplanes of this period were retired from front line service, four distinct types were produced, E-1 to E-IV, inclusive. All were very similar in appearance, differing only in size, weight and power. They were developed from Fokker's 1914 M-8 monoplane in which he looped and stunted all over Germany just before the outbreak of W. W. I. Pressed into service because they were available, the first dozen or so such single seat "scouting" planes fitted with the machine gun were called the E-1.

Although not designed as gun fighters, these little planes could not miss—they had no competition! The E-1 was powered by an Oberursel UO model 80 hp rotary of seven cylinders. Overall length was 22 ft. 3 in.; wing span was 29 ft. 6 in., and height, 8 ft. 6 in. It weighed 787 lbs, bare (not to be confused with "empty" weight) and 1,240 lbs, fully loaded. The difference was made up in fuel, oil, the machine gun, ammunition, pilot and equipment. So loaded, the sea level top speed was 80.5 mph. The E-1 climbed to 3,300 ft. in 7 min.; to 6,000 ft. in 20 min., and to 9,900 ft. in 40 min.

Models E-II and E-III were by far the most successful of the Fokker monoplanes. The two models were identical except for engines. The E-II was fitted with an Oberursel UI, 9 cylinder rotary of 100 hp, and the E-III carried an Oberursel UR II delivering 110 hp. More of these two types were built than any other of the Fokker monoplanes.

**Fuselage structure**—Steel tubing was used throughout the basic structure. Except for a few secondary members, longerons, uprights and cross pieces were joined by welding. The frame was cross braced with steel wire. In side elevation the fuselage was approximately symmetrical. It was flat on all four sides except forward of the cockpit, and finished off at the tail in a horizontal knife edge.

The curved cowling in front of the pilot was a segmental continuation of the engine cowl, forming the only protection from the wind for the pilot. Windshields were fitted, of course, but did little good and were often removed by the pilots. The cowling was formed of sheet aluminum resting on and attached to tubular steel formers and the longerons. Inspection doors, filler caps for the oil tank and for other necessary items were provided as needed.

The engine cowling was formed of sheet aluminum, cut away at the bottom so ex-

(Continued on page 48)

Identification Tag Will Be Engraved With Your Name

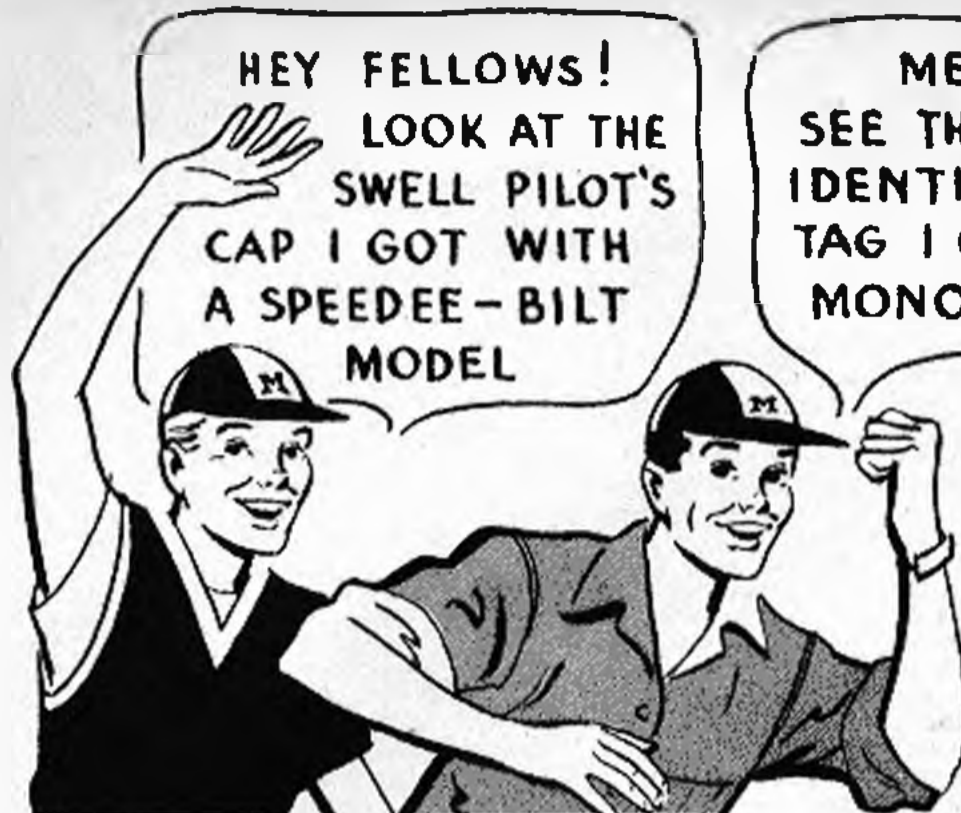

### Get Your Pilot's Tag and Cap—Fellows!

Cap or Tag Sent for One Speedee-Bilt Box End and 25c. Send Two Box Ends and 50c for Both.

It's the new long-peak pilot's cap that smart fellows are wearing. Identification tag, engraved with your name, is airplane metal, with safety catch and chain to fit the wrist. Send one from Sabre Jet, Corsair or Warhawk box and 25 cents in coin for your choice. Send 50 cents and two box ends if you want both cap and tag. Write plainly. Mail to address below.



**MONOGRAM**  
Sensational · Exciting · New  
**SPEEDEE-BILT**  
flying models

The Finest Models Monogram Has Ever Produced—With Many More Sensational Features—and More for Your Money Than Any Other Kit.

**ONLY 85 CENTS**

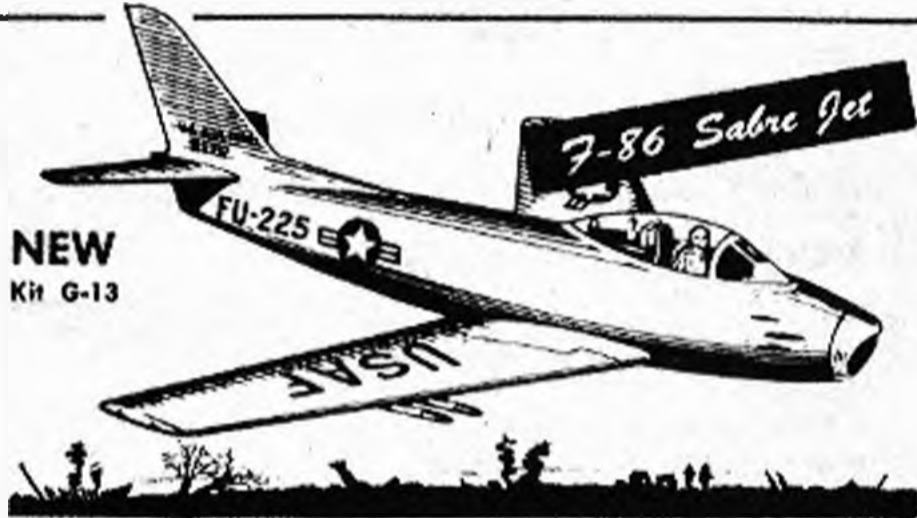

**NEW**  
Kit G-13

Swept-Back Wings • Deadly Fire Power

All These Parts in This Kit—Plastic Cowling—Plastic Pilot—Plastic Rockets (4)—Plastic Exhaust—Famous Monofoil Wing (Right and Left)—Prefabricated Fuselage and Tail Parts, in

Full Color and Die Cut—Plastic Canopy (Detail Molded)—3-Color Decals—Rubber Wheels—Metal Landing Gear, (Specially Formed)—Detail Picture Plans and 9 other parts.

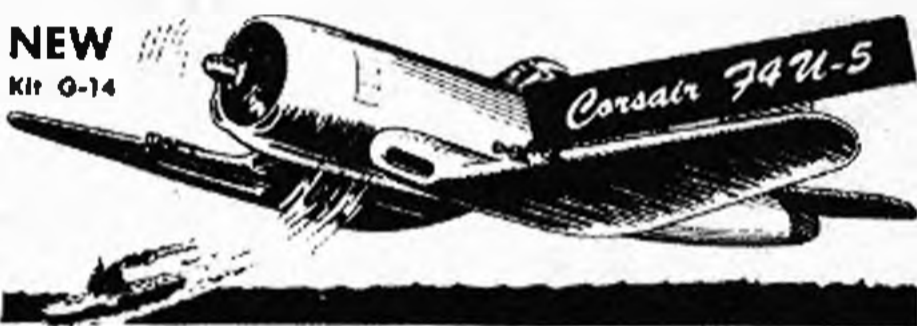

**NEW**  
Kit G-14

Gull Wings Easy to Build • More Simplified Construction

Corsair Parts List—Four-Bladed Plastic Prop—Plastic Cannon—Plastic Pilot—Plastic Cowling—Prefabricated Fuselage and Tail Parts, in Full Color and Precision Die Cut—Monofoil Wings (Right, Left and Center Sec-

tions)—Three-Color Genuine Decals—Rubber Wheels—Landing Gear (Specially Formed)—Plastic Canopy (Detail Molded)—Rubber Loop—Detail Picture Plan and 11 other parts.



**NEW**  
Kit G-15

The All-Time Favorite • Ferocious Tiger Mouth Decals

Build With These Parts—Three-Bladed Plastic Prop with Plastic Spinner—Plastic Pilot—Plastic Exhausts—Plastic Cowling—Prefabricated Fuselage and Tail Parts, in Full Color and Precision Die Cut—Monofoil Wing (Left

and Right)—Formed Plastic Canopy—Rubber Wheels—Complete Landing Gear—Three-Color Genuine Decals—Rubber Loop—Detail Picture Plans and 12 other parts.

## How About it Fellows?

Now . . . the models you have always wanted. Compare these kits with any others and you will see why Speedee-Bilt gives you more value—more fun.

We told you last month how thrilled we were with our three new SPEEDEE-BILT MODELS—the models so many of you asked for. We know you are thrilled with them too, fellows, and that never before have you seen such fine kits and such big values.

And when you get to building them—Oh Boy! Such fun! Such realism! The three and four-bladed plastic props and other plastic parts added to the other outstanding SPEEDEE-BILT features, make building so easy and make you so proud of your finished models.

Build all of the new models. Get a SPEEDEE-BILT long peak pilot's cap and the identification tag too. They add to the fun when you fly your models.

If no dealer in your neighborhood order from address below. Send 25c additional for shipment from nearby dealers stock.

**MONOGRAM MODELS, INC • 225 N. RACINE AVE. • CHICAGO 7**

# San Francisco Fuels

## FIRST... FINEST

in the field of Racing Fuels

- Acclimatized Volatane Control.
- Purity Protected.
- Proven Performance.

YOU ARE ASSURED OF THESE IMPORTANT FACTORS IN EVERY DROP OF

### POWERMIST • SPITFIRE BLUE BLAZER

**FUEL OF THE CHAMPIONS**

FROM THE WORLD'S FIRST, LARGEST, BEST EQUIPPED RACING FUEL LABORATORIES

FRANCISCO LABORATORIES 3801 BRIDLE VIEW DRIVE LOS ANGELES 28, CALIFORNIA

## NEW! 1/2 A FLYING SCALE CORSAIR



Beautiful, precision half "A" flying-scale model! P-51 & Corsair ready! Kits contain carved, hollowed fuselage, cut-to-shape wings, stab, rudder and super detailed plans.

**\$2.95 EACH**

**HELL RAZOR**

World's finest precision model! New 1/2 A HELIX, HAZOIL-RTM (1/2 D" span \$2.00; 1/2 1/2" original, with MAGNETUM bottom, Class "A" \$3.95; 1/2" \$4.50; "C" & "D" \$5.00.

MAIL ORDERS FILLED (No C.O.D.)

# Consolidated

3187 3RD AVE. (MA-9), NEW YORK 56, N. Y.

## Here Come The Jets

(Continued from page 19)

counter the lower ideal efficiencies as a result of high exit velocities. The tests to date show that if the ducts are carefully designed and fan tip clearance is kept to a minimum the jet models fly very well.

The critical feature of the system is designing suitable inlets and exits. A study of existing jet fighter designs indicated a trend to larger inlets and exits because of grouped engines or addition of afterburners. Actually any design where the inlet opening can be enlarged without destroying outline proportions can be powered by a ducted fan. This is true because the inlets can be camouflaged. The F7U-1 picture shows the inlet opening. It can be seen that the air merely drifts sideways into the fuselage and is then accelerated to the rear. Thus the side area of the screened opening becomes the inlet area and this area is much larger than the fan frontal area. Another form of opening is a ramp type as shown on the F90; however, this type is not so realistic and is more difficult to design. Figures one and two at the end of the article show the effect of the inlet and exit areas on static thrust. This data is actually measured data taken from the models themselves. Only a few tests have been run on the F7U-1 to date but it has flown successfully and appears to have good power characteristics. Figure three shows the effect of engine speed on static thrust. Also shown is the large gain in static thrust when an engine powerful enough to drive a six-blade fan was installed in the airplanes. Since installation of an .048 engine in the F90, it has flown consistently.

A word about stability to indicate the basic problem. Model stability is in a large measure determined by power effects. This is so because the model is unable to change trim settings between power-on and power-off flight. A good feature of the ducted fan system is that it is torqueless. The system is torqueless because flow straighteners must be added just behind the engine to effect a pressure recovery and increase the axial velocity of the air. These flow-straightening vanes also support the engine mount as shown in the diagram of the F90. The fact that airplanes have swept wings and large fuselages does not rule out the possibility of scale free flight. Modern fighter design demands upon exhaustive stability and control studies and most of them are designed to have only slight spiral tendencies. A little dihedral and the usual enlargement of the horizontal surfaces is generally sufficient for stability. The absence of torque in the ducted fan allows easy flight adjustment. Just be sure the center of gravity is a little ahead of the aerodynamic center of the model. A good example of how stable these airplanes are is the F7U-1. It is exact scale except for about two degrees of dihedral; yet it flies very satisfactorily.

The F90 and the F7U-1 are the third and fourth models of this nature to be constructed. The first model was a flying test stand and it made many flights but had no particular scale proportions. The second model was scaled from the DeHavilland Venom but in spite of its stable appearance

the jet effect on the horizontal surface created serious power effects. This fact almost discouraged the further development of the system, but after building the F90 it proved that the jet could fly. Possibly a higher position for the horizontal surface on the Venom will correct the stability problem.

The F7U-1 has been flying on Infant power and climbs at a weight of five ounces. The fan for the Infant is three bladed and is made of 24SO aluminum. Balancing is no more critical than for regular propellers. One difference is that the fan is in a tube and the tip clearances must be fairly close—about 1/16 of an inch. This means that at some critical speed the engine will vibrate. This must not occur at the operating speed. If it does, the mount

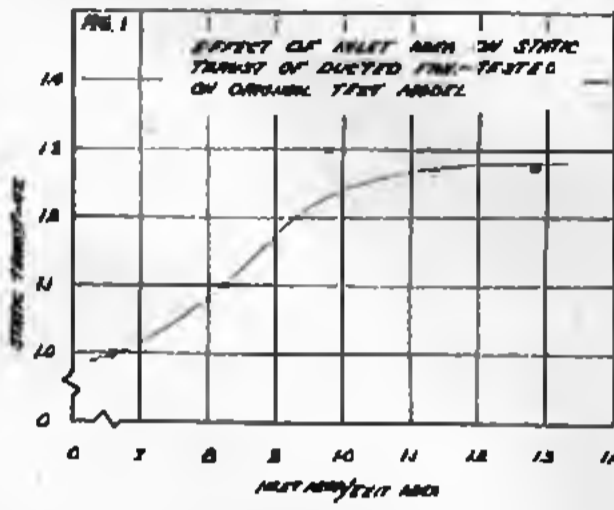

must be made either stiffer or softer. If the mount is softer, the engine will pass through the vibration stage and then smooth out during adjustment. If the mount is made stiffer the engine will never reach the vibration stage. Either change will be satisfactory provided the mount structure is not too seriously weakened.

Certain operational problems had to be worked out before flight testing could be started. The most important problem was engine access for starting, adjusting, and for installation and removal. An access door on top of the fuselage seems to be the most prac-

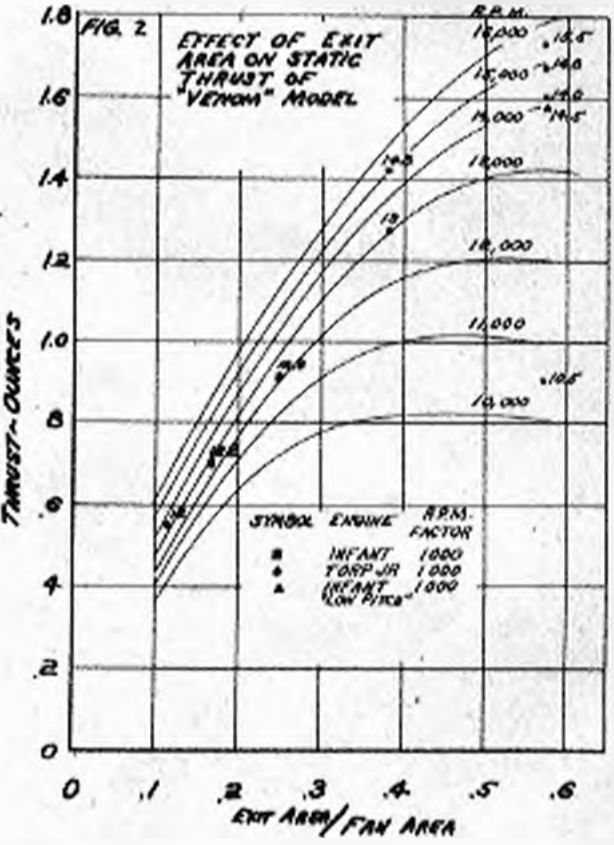

tical means of servicing the engine. This door must have some sort of spring latch that snaps on, closing the door. This reduces time between starting and launching to a minimum. Starting was simply accomplished by using a narrow strip of friction tape. The tape was wrapped around a hub at the base of the fan and then pulled for starting. The hub was made by putting a hole in a dope bottle cap and mounting it behind the fan. Engine adjustment after starting is accomplished with an extension rod for the needle valve. This extension may be left on the engine after the tube is closed if a slot is provided in the access door. It has been found, however, that the engine can be adjusted with the door open, the extension

WHOLESALE ONLY

## Easy Does It!

### For Hobbycraft Dealers Everywhere

It's easier to run a model and hobby store with National's Check List to help you. Keeps you informed. Makes ordering and stock-keeping a cinch. Simplifies all retail operations, big or little. Now 70 pages, listing more than 10,000 of the best selling hobbycraft items. Model railroads, airplanes, ships, engines, engine parts, race cars, tools, supplies and handicraft items. Write today.

NATIONAL MODEL DISTRIBUTORS, 2516 N. Greenview Ave., Chicago



rod removed and the door closed just before launching. All models have been hand launched to date in lieu of building a gear. This also makes more realistic flights since full scale jets all have retractable gears.

Installing and removing the engine is simple if a long screwdriver is purchased at the dime store; the screwdriver should be able to reach the mounting bolts when it is introduced through the intake openings. A spinner on the fan will give some slight performance gain but it is not necessary for good flying. Fuel tanks may be mounted anywhere but a forward location is preferable. The engine should be ahead of the airplane center of

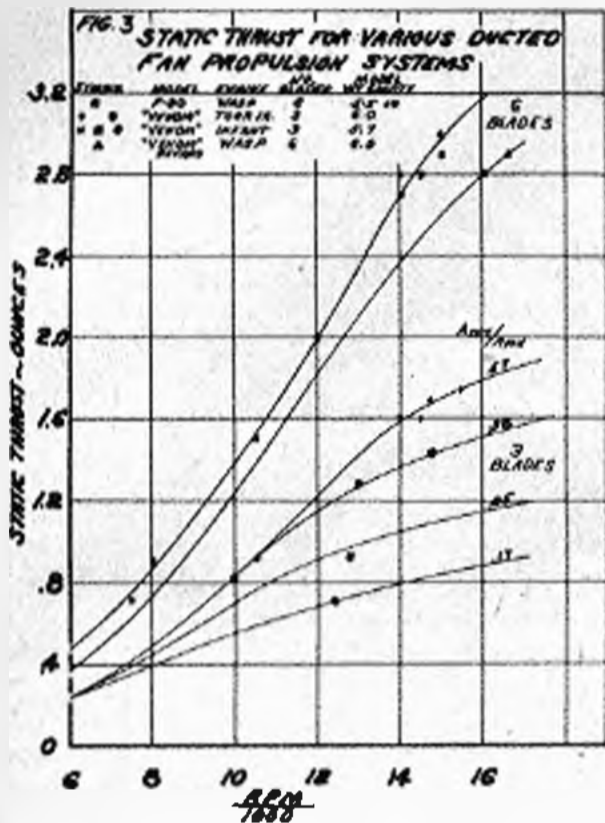

gravity so that if a larger engine is desired it will not destroy stability.

The duct walls to date have been made of 1/32 inch balsa sheet stock. Soak them in water and wrap them around any convenient tube of approximate size. Hold them in place with rubber bands until dry. The structure is fairly conventional. Bulkheads are stronger and easier to make if they are made from a sheet of balsa covered on both sides with tissue paper. Multiple stringer construction for the wing makes a resilient structure while maintaining a good aerodynamic surface. Care must be exercised in designing the carry-through structure for the wing since no

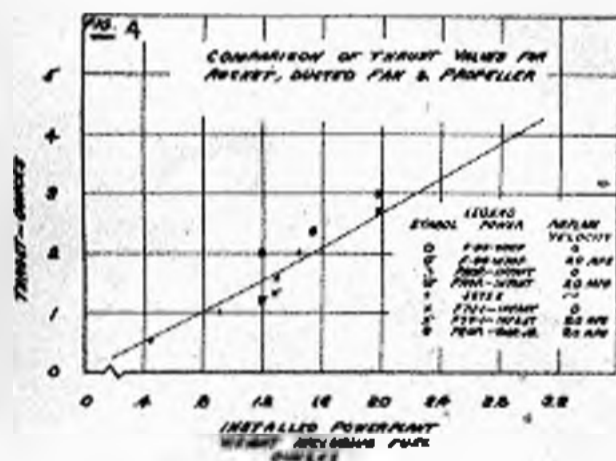

comparison can be placed in the jet tube. The multi-stringer construction eases the carry-through problem and gives high torsional rigidity to the wing.

In conclusion it can be said that true scale jet flying is possible with existing devices in the model field. Most AA engines will run at 15,000 RPM which is sufficient for good thrust. The chart shown in figure four compares ducted fan, rocket, and propeller thrust on the basis of total power plant plus fuel weight. It can be seen that the ducted fan is satisfactory and in line with other means of propulsion. Much development work remains but the device has been proven so you experimenters can really get some thrills if you hitch your swept wings to a ducted fan. END

# 8 New Stars On The Cleveland Pennant!



**"SIMPLEX" KITS \$1 ea.**

**ANNOUNCING ANOTHER IMPORTANT CLEVELAND "FIRST" - THREE SWELL "SIMPLEX" FLYING JETS** They're Cleveland's brand new, grand new kit line. Only \$1 each yet look what you get—Three fresh authentic C-D scale designs with all-diecut interlocking parts, an automatic bulkhead lineup in a strong, light keel, plus tapered, shaped and notched wing edges, three-color decals, the best tissue, beautifully moulded canopies, pre-bent landing gear wire, a lightning bulkhead notcher, and many other features that make for smooth, fast assembly! Remember the name "Simplex" and get yours today!



**"QUICKY" SETS 59¢ ea.**

**"QUICKY" SETS BUILD FASTER, LOOK MORE REAL, AND FLY BETTER THAN ANY SIMILAR MODELS!** No cutting, no covering, no painting! — Just assemble and fly! Believe it or not, it can be done in just 10 1/2 minutes! The parts are colorfully decorated in realistic detail just as they come. A one piece completely finished, 18" wing, and a big, indestructible plastic prop, plus the lightness and ruggedness that result from their ultra-simplicity all go to make them tops. They are engineered to fly several hundred feet! Buy 'em all, build 'em all, and fly 'em tonight — you'll have the time of your life!



**1" SCALE "SGP" KITS**

**BOEING P 20A \$6 95**

**GREAT LAKES TRAINER \$5 95**

**BUILD THESE, AND BE PROUD OF THEM!**

- Almost one sq. ft. of decals in P-20A
- Shaped, notched leading edges
- Tapered, notched trailing edges
- Preformed wire
- EVERYTHING diecut!
- Great cowl turning (P-20A)
- Preshaped wing struts
- Easy-interlocking bulkheads and keel construction (or notched sheet sides)
- Routed-out wheel shoes
- Brilliant, colored "Skyball" gas model tissue
- Tails are diecut sheet
- Handy Bulkhead notcher in ea. kit
- Stunt and sport rib

**WHEN ORDERING BY MAIL:** (If your dealer is out of stock! Do not accept substitutes for C-D's but order direct. Orders under \$1. not accepted. (No C.O.D.'s.) Include 35¢ pack-post. to all orders up to \$3.50, over \$3.50 add 10%. (This includes A.P.O. and U.S. Possess.) Foreign customers add 10% for special handling, etc., in addition to pack post charges. Special Delivery in U.S.A. only, 35¢ extra. Ohio residents add 3% Sales Tax. Send 3¢ stamp for illustrated airplane circular.

**CLEVELAND MODEL & SUPPLY COMPANY**  
4507K1 Lorain Ave.,  
Cleveland 2, Ohio, USA

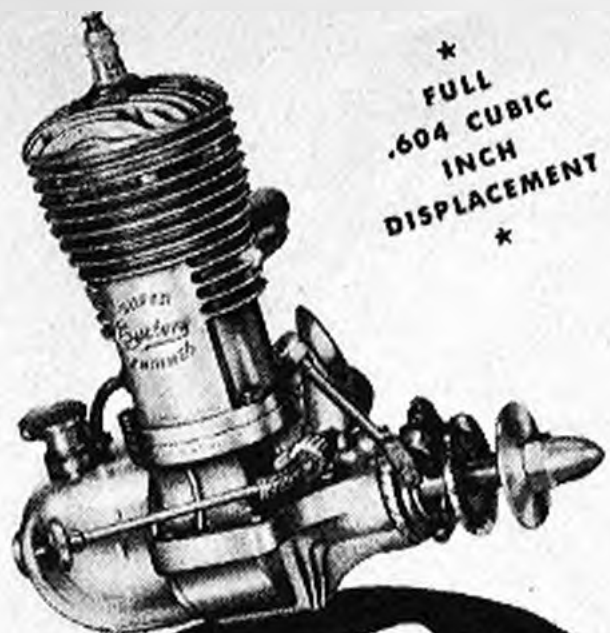

\*  
FULL  
.604 CUBIC  
INCH  
DISPLACEMENT  
\*

**SUPER-  
CYCLONE**

NEW LOW PRICE  
**\$12.95**

AT YOUR FAVORITE DEALER

The easiest to start, all purpose, precision built engine. It has a background of dependable and winning performance. Thousands in use for precision flying, free flight, U-control and experimental flight.

**SUPER-CYCLONE  
HAS BEEN  
SUPER-TESTED**

Every engine is run on test stand before leaving the factory and is guaranteed for a period of 60 days from date of purchase. Super-Cyclone will give you the efficient performance you want.

**Buy  
SUPER-CYCLONE ENGINES  
AND PARTS FROM YOUR  
LOCAL DEALER**

Manufactured by  
**SUPER-CYCLONE**  
GRAND CENTRAL AIR TERMINAL  
GLENDALE 1 • CALIFORNIA

## Can You Really Fly

(Continued from page 10)

taking the ship from carrying box at the flying site and flying. Assemble ship as described above and check by looking model over carefully. Select a loop of rubber two or three inches longer than motor stick. Do not attempt to wind by hand as the propeller is too fragile should the shaft hook snag while tightening slack in motor. Use a winder of about 20-to-one ratio or more and stretch motor about three times its length. Put in about 500 turns and once again look ship over before launching. Release model gently (less than walking speed). It should hold its own, but if it dives, increase incidence about 1/16" at a time by pulling front strut up in the paper tube. If ship has stalling tendency, reduce wing incidence by pulling rear strut up about 1/16" at a time. When ship looks properly trimmed increase winding by 200 or 300 turns at a time until maximum is reached. By experimenting with different rubber thickness and length of loop you will obtain the maximum performance from your model.

**HAND LAUNCHED GLIDER:** Bob Dargand's Lucy series of gliders have had unusually good results both indoor and outdoors. His latest Lucy XX holds the Class B World Indoor Record with the amazing time of 1:13.6. The wing has a straight leading edge with elliptical tips and made from 1/4" x 3-1/2" stock. Maximum camber thickness is 25 percent back of the leading edge and a sharp leading edge is used. The airfoil has a flat bottom and the wing is mounted at zero degrees incidence on top of the fuselage. The horizontal tail is a thin airfoil section and mounted with zero degrees incidence on the bottom of the fuselage. Rudder is mounted straight. Center of gravity is about 85 percent back from leading edge. His outdoor gliders have a ten-degree sweepback in the wing which places the C.G. near the trailing edge. Jasco tapered 3/16" x 3" stock is used here and maximum camber thickness 33 percent back of leading edge. It is slightly rounded under leading edge and has a flat bottom. All parts are given polished finish before final assembly.

Both types of gliders may be flown outdoors for test flights. Select early morning or late evening during calm air. A grass field such as a baseball park will not nick up the model and absorbs some shock in event of hard landing. Bob uses an adjustment in flying gliders similar to that Tex Rickard originated in the mid-1930's. A right-handed person should warp the rudder to left slightly, right-wing trailing edge warped down (wash-in). In Bob's model it is necessary to warp the whole trailing edge down slightly on the tail or it will require too much clay to balance properly. Hold glider with thumb and forefinger, then slip model straight away from you. It should rise slowly almost to a stalling position and then kick over the hump into its left circle glide pattern. When you're satisfied and ready for a fairly hard launch, give it enough throw to follow through without stalling. Maximum performance will be obtained when ship comes out just about overhead or a little to the right. Pull-out too far in front, back or left, means it is not perfectly adjusted and you are wasting your precious arm. The glider should launch into a long sweeping climb with the roll-out coming in as the last bit of power fades and then go into its flat left glide without hesitation. Gliders flown this way assume a nose-high attitude in gliding. Once you get to know your ship you will realize that hand launched gliders offer much satisfaction for the small work spent building them.

**SPEED:** Keith Storey is one of the most successful speed flyers, having won several Plymouth and National events. The set-up used by him on his ships is described here. His wing airfoil is an N.A.C.A. 2209 set at zero degrees incidence. Horizontal tail surface is a thin symmetrical section made from 1/16" thick plywood and mounted at zero degrees incidence. The motor is mounted with two degrees left-thrust to lessen the pull on flying wires and also serves to increase efficiency of the propeller. No downthrust is used on this type of ship. Since there is no rudder to offset torque, it is essential to have a wide tread dolly that will run true until the ship

has built up speed before take-off. Torque is then no longer a problem as centrifugal force holds the inside wing level due to the flying wires. Large wheels help especially in flying off grass. The C.G. is 20 percent of the chord and the bellcrank is mounted 30 percent of the chord.

Choose a smooth flying field and walk around the flying circle, removing all small rocks or obstacles that may cause trouble. A calm time of day, early morning or late evening, is safest to test fly your ship. Instruct your mechanic helper on his part in starting and arm signals for releasing ship. Unroll flying wires and place the handle exactly as it will be used on ship. Fuel up and start the motor with a mechanical starter. Run motor up to top R.P.M. A rich mixture may work best as motors tend to lean out after gaining speed. Take your place at the control handle and when you're sure the motor sounds good, give the prearranged release arm signal. The helper should be holding ship down on dolly and it in turn should be pointed straight ahead. A slight push on the ship will help the propeller take hold quicker and accelerate. Let the ship run on ground until it reaches flying speed, about 23 percent to 50 percent of circle and give a little up elevator for taking-off. Neutralize controls as soon as possible, not going over 16 foot high, and level off to build up speed. Climbing any higher may result in a crash. Go around several laps to familiarize yourself with the controls. When the ship has reached its maximum speed raise your arm to signal the helper that you wish the ship to be timed. Hold ship level in test run. After motor stops ship glides for several laps and can be brought in for nice smooth landing. By stepping back and to left, you can tow ship and keep under control at all times for good landing.

**TEAM RACER:** Many members of the F.A. S.T. Club, which originated this new event, use a thinned Clark Y airfoil of from 1/4" to 1/2" thickness, set at zero degrees incidence. This airfoil gives the ship a high top speed, but with the 125 sq. in. area, the landing speed is fairly slow. The horizontal tail surfaces are a thin symmetrical airfoil of from 1/16" to 1/8" thickness set at zero incidence. No downthrust or side thrust in this type of model. Rudders are set with five degrees right in order to offset torque. The lead wires are installed with 1/4" slant to rear on wing in order to keep the nose pointing out and pulling on the lines. A wide landing gear is essential to prevent ship from turning in upon release. A minimum of seven inch tread is recommended with eight to ten inch preferred. Mount the landing gear true so wheels run straight ahead. The weight of the flying lines and the slight tension caused by the pilot often causes the left wing to dip upon take-off and turn ship into the circle with disastrous results. Therefore a counter-balance weight of two oz. of solder weight is placed inside the right wingtip to hold the outer wheel on ground. The C.G. is at a point ten percent back of the leading edge and the bellcrank is mounted 35 percent of the chord.

Select a level field and remove all rocks or anything in the flight circle that may cause trouble. Your mechanic helper should be instructed on arm signals for releasing ship. Unroll flying wires and lay them out just as they will be used on ship. For testing, it is wise to use a propeller with slightly higher pitch such as a nine inch dia. by ten inch pitch. This will give you a slower and longer take-off which is safe at this critical time. Later a 9 x 8 propeller for high speed can be installed. Start motor and run it up to top R.P.M., then take your place at control handle. The helper should hold the ship with nose pointing out about five degrees angle for taking-off. It is very important that your mechanic does not push the ship, just let go. Explain this to him. Raise free hand and when you are sure everything is ready, drop this hand as the release signal. Let the racer gain speed by running from 50 to 70 percent of circle on ground, then give it a little up elevator and level off ten to 15 feet high. Experiment with the controls after a few laps and become familiar with its handling characteristics. Hold the ship level and when the fuel runs out, nose down slightly to land.

(Continued on page 44)

**TOP FLITE**  
MODELS INC.

You 1951

# NATIONALS WINNERS

**Proved it Again**

**JULY 23-29, '51 at Dallas, Texas**

You proved for the **FOURTH** consecutive year that most champions use Top Flites and Power Props! Everybody knows you did a lot of testing to get the most performance out of your models. In propellers, you want the most pull—and we at TOP FLITE appreciate the compliment when you select more **TOP FLITES** and **POWER PROPS** than all other makes combined!



Carl Goldberg

**FREE FLIGHT GAS**

Cl. AA Junior Don Tune L.A., Calif. Perf: 13:29, Torp .049 6/4 Power Prop	Cl. B Open Ernie Shailor Detroit, Mich. Perf: 21:41.4, Forster 29 10/3 1/2 Top Flite	Cl. C Open Bob Ottoman Medford, Oregon Perf: 28:05.4, Torp 32 10/6 Top Flite
Cl. AA Open Dick Everett San Diego, Calif. Perf: 22:05, Torp .049 6/3 Top Flite	Cl. C Junior Curtis Franke San Antonio, Texas Perf: 18:43, Torp 32 11/6 Top Flite	Row Junior Bill Lofland Abilene, Texas Perf: 4:11.8, Veco 29 9 1/2/6 Power Prop
Cl. AA Senior Jack McComb Columbia, Mo. Perf: 15:07.6, Wasp .049 6/4 Top Flite	Class C Senior Don Murray West Point, Ga. Perf: 22:00, Triumph 49 11/6 Top Flite	Row Senior Edward R. Male Chicago, Ill. Perf: 11:27, OK Cub 09 7/4 Top Flite

**U. S. NAVY**

Radio Control Bombing  
Open  
Clifford Schalble  
Roselle Pk., N. J.  
99 1/2 pts., McCoy 19  
9/6 Top Flite

Carrier Control Line  
Open  
Bob Lutker  
Fort Worth, Texas  
253 pts., Fox 35  
10/6 Top Flite

**PAA LOAD  
Class AB**

Junior  
Michael Cook  
Glendale, Ohio  
Perf: 3:36.6,  
Ohlsson 29  
11/4 Top Flite

Open  
Herb Kothe  
Grand Prairie, Texas  
Perf: 15:19, Torp 29  
11/4 Top Flite

**CONTROL LINE**

Flying Scale  
Senior  
Juel Clevenger  
Kansas City, Mo.  
Atwood 49  
10/8 Top Flite

**CONTROL LINE**

Speed Cl. A  
Junior  
Tommy Davis  
Atlanta, Ga.  
110.56 MPH, McCoy 19  
7/9 Power Prop

Precision Acrobatic  
Open  
Lou J. Andrews  
Norwood, Mass.  
382 pts., Fox 35  
10/6 Top Flite

Precision Acrobatic  
Junior  
Harris Grimes  
Atlanta, Ga.  
324 pts., Veco 29  
10/6 Top Flite

Flying Scale  
Open  
Chief John K. Abbott  
Corpus Christi, Texas  
McCoy 49  
10/6 Top Flite

**Team Racing**

Open  
Bob Lutker  
Fort Worth, Texas  
454 pts., K & B 29  
9/9 Power Prop

**FELLAS! FLY THE PROPS OF CHAMPIONS!**

UNIQUE ENGINEERING DELIVERS MORE PULL

Pick up a Top Flite or Power Prop and notice the rounded edges and thin trailing edges! Note the extra smooth finish and the balance. For better results try them and you'll agree with the Champions—it's the unique engineering hidden in the design that makes Top Flites and

Power Props deliver More Pull!

Whatever your choice—Free Flight, Stunt, Speed, Payload, Scale or Sport Flying... there's a Championship Prop of the Size and Pitch best suited to your Engine. Try them... You'll always Fly 'Em.

**NO GUESSING WITH TOP FLITE PROP CHART.**

Do you want to know what size and pitch of Prop to use with your Engine and Airplane? The Top Flite Prop chart tells you quick as a wink. Ask your dealer!



**TOP FLITE Models Inc., 2635-45 S. Wabash Avenue, Chicago 16, Illinois**



## SHIPS of the 7 SEAS

**SUPER  
PRE-FAB  
KITS**

**XEBEC  
\$2.50  
KIT**



# Constructo

NAUTICAL MINIATURES

This is a Maritime Series \$2.50 kit. All wood parts completely finished for instant assembly, even by a beginner. Each is numbered and seen on cardboard for easy identification. Complete step-by-step instructions, new type glass make all CONSTRUCTO kits astonishingly easy to assemble.

**ALL PARTS MACHINED  
& FINISHED & PAINTED**

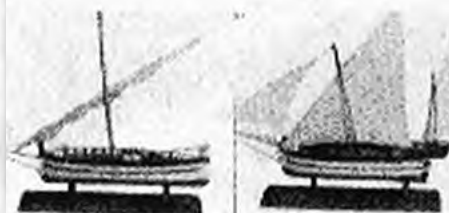
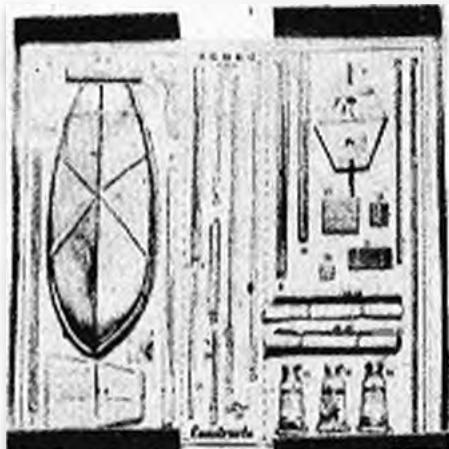

CATBOAT KIT \$2.50

FELUCCA KIT \$2.50



**LOOK FOR  
UNIVERSAL COMPACT**

Displays at your dealer's showing the finished models you can easily build from CONSTRUCTO'S 75c kits. They make up into charming, decorative ships for den, living room, office or library.

**CHINESE JUNK "LUCKY CHINA SHIP" 75c. 57 parts in 5 colors. Classic corsair of Chinese and Malayan architecture.**



**ORIENTAL GALLEY "FUNEE" 75c. 46 parts in 5 colors. Quaint, colorful fluted warship of 17th C.**

**YACHT "ENDVOUR" 75c. 55 parts. Even the spars are inserted into mast in this sleek model of famous champion.**



**YANKET CLIPPER "GREAT REPUBLIC" 75c. Contains 72 parts. Four-ply rigging makes this kit interesting for the more advanced builder.**



**COASTAL TRADE SCHOONER "GALETA" 75c. Contains 44 parts. Easy to build classic 17th Century merchant schooner.**

MODELERS: TRY YOUR DEALER FIRST. IF NOT AVAILABLE ORDER DIRECT. DEALERS: Constructo is distributed by leading hobby wholesalers everywhere and in the East by—

**POLK'S MODEL CRAFT** 314 FIFTH AVE. NEW YORK 1, N.Y.  
DEPT.-MA-3 **HOBBIES**

It will continue for another lap due to its speed, but as the ship slows, you can ease her in for a two-wheel rolling landing. A little footwork on your part will help in landing by stepping back and to left side to keep lines taut. Try stogie take-offs when you are sure of your ship.

**STUNT:** J. C. "Madman" Yates is well known for his precision acrobatic stunts. His ships are realistic in appearance and performance. He uses an N.A.C.A. 0018 symmetrical airfoil set at zero degrees incidence. The horizontal tail is a symmetrical section also set at zero degrees. Rudder is offset four or five degrees in right in order to offset torque. The right wing is warped down on leading edge (wash-out) about 1/2 degree to aid in offsetting motor torque. No side or down thrust in motor. Mount it straight away. J. C. believes in using plenty of power and depends on the Orwick .64 engine and 12 x 7 Y&O propeller for maximum efficiency. Add enough weight to outside wingtip to slightly over balance the weight of the lead wires on the inboard wing. J. C. builds the complete Yues-lage, motor and tail assembly, then mounts wing in proper position. Center of gravity is 25 percent back from leading edge and bellcrank also is located at this point. The location of lead guide is very important. Center of the two wires at wing tip should be about 1/4 to 3/8" back of C.G.

A level field that is smooth and free of rocks, etc., is best for testing your ship. Be careful where you fly and look for any high-tension electric lines. Stay away from them as they are extremely dangerous should your ship touch them. Now unroll the flying wires and lay control handle on ground just as it will be used for flying. Instruct your mechanic helper on arm signals for releasing ship. Fuel up and start motor. Run it up to R.P.M. and take your place at the control handle. The ship should be held by the mechanic so nose points out five degrees. He should be instructed on this and also be told not to push on releasing model. When motor sounds good and you are sure everything is O. K. give the prearranged arm signal for release. Hold the ship on the ground until it gains flying speed and give a little up elevator after running about 25 to 33 percent of the circle. Level off after gaining ten or 15 feet and continue level flying for several laps to get the feel of the controls. Don't try any tricky maneuvers on this first flight. Some simple diving, climbing and perhaps a wing-over may be tried at this time. As the end of motor run approaches, level ship and hold until engine conks. Nose down slightly to keep flying speed and just before ship touches give a little up elevator for landing. You can control the landings by stepping back and to left and tow the ship. This is especially effective if ship shows any tendency to stall.

**U-C FLYING SCALE:** While flying scale model ships involve the maximum of time and workmanship, the author has found that they compensate for this by being fairly easy to adjust for flying. A model of the W.W.I. Spad employed a Clark Y Airfoil in both wings, set at zero degrees incidence. This type of flat-bottomed airfoil is easily mounted as you have no trouble in locating the reference line. Also it performs well in the air and results in slow landings which are desirable on scale ships. The horizontal tail is symmetrical and mounted at zero degrees incidence. Motor is mounted with zero degree thrust in plan and side view. The rudder is held to vertical fin with aluminum alloy tabs for adjustment on the flying field if necessary. Using a 11 x 6 propeller on the Triumph .49 motor required ten degrees right rudder, but if high pitch propellers such as 11 x 8 are used, then increase to 15 degrees right rudder in order to offset torque. Mount the landing gear so wheels run straight ahead. The bellcrank is mounted at a point measured back from the leading edge about 35 percent of the wing chord. The C.G. is at a point about 25 percent back of the leading edge. The lead guide is mounted so that lead wires sweep back 1/4" at lead guide. This keeps nose pointing out.

Select a level field and inspect the flight circle for any rocks, etc., that may cause trouble in taking off and landing. Instruct your mechanic helper on arm signals for releasing ship. Hook-up your flying wires and place control handle at center just as it will

be used for flying. Start your motor and run it up to top R.P.M., then take your place at control handle. Raise your free arm, which is the prearranged signal, and when you are sure everything is ready drop the upraised arm. The helper should hold the ship with the nose pointing out about five degrees for taking off. Let the ship run on ground to gain speed and as it gets about 25 to 33 percent around the circle, give it up elevator and climb about ten or 15 feet before leveling off. Go around a few laps to acquaint yourself with handling characteristics of the ship. When you are sure of its response you can try some simple maneuvers. As the motor nears the point of running out of fuel, level the ship and keep it this way until it conks, then nose down to keep flying speed and bring it in for a nice rolling landing. With a little practice you can learn to make a three-point landing by using a little up elevator just before ship touches the ground. Just like flying a big ship. **END**

## We Test The Senior

(Continued from page 23)

necessary to trim in spots. Before cementing ribs in place, put cement on the rib and main spar areas that will be against each other before finally locking ribs in place. This will make for a much stronger bond. Also use additional cement as prescribed in plans. Handy-tip: lay the leading edge spar along the main spar, mark the position of the ribs and cement that in place before the trailing edge to prevent the main spar from being pulled out of place. Slip trailing edge of ribs into the notches and check for length. Trim ends of ribs if necessary. After cementing the two sections of the trailing edge together, check for alignment before setting up to dry. The leading and trailing edges should be straight and the ribs an equal taper top and bottom from the center out.

Wetting the outside of the leading edge sheeting when cementing takes the strain off the wood and helps prevent warping. The reader may have found that most wings seem to be weakest at the corner formed by the center section planking and the leading edge planking. By replacing a section, about 1-1/4" wide, of the center section planking next to the leading edge, making that piece about 1-1/4" longer on both sides and rounding that corner, considerable strength can be gained. While not essential, this procedure will help any stunt model.

As another handy hint, cut a small notch in the hardwood spar of the elevator to make the control horn flush with the front. Also by so doing, it is possible to slip the control horn on later, thus making it possible to assemble the stabilizer and elevator on a flat surface.

If you decide to solder the clips to the landing gear mounting eyelets as suggested in the plans, use a nut and bolt to hold the clips tightly in position and it is not necessary to have them on the firewall while soldering. Whereas the plans show screws for mounting the engine and the bellcrank, bolts may be substituted if desired.

Before putting on the first side, we gave the fuselage a coat of Testor's clear Sta for additional strength of the wood, but not on the areas to be cemented; also we mounted the motor at this time as we happened to use bolts and wanted to put cement on the nuts. We also gave the motor additional offset with wedges under the motor, although this is not really necessary. If you are going to make a hatch for access to the motor (it is recommended) the motor may now be taken out and set aside until the plane is near completion.

In fitting the sides we beveled them first, then cutting and sanding very little at a time, rested for a perfect fit. It will pay in looks and strength to do this slowly and well. Be sure to keep the wing and tail slots lined up while fitting. In cementing on the side, we found it easiest to put cement on the keel and edges of the bulkheads, press the side into position, then

(Continued on page 46)

*"Spitzy"* **NITROMIC**  
**"BALANCED POWER"**  
**GLOW FUEL**

**FOR SMOOTH, NITROMIC POWER**

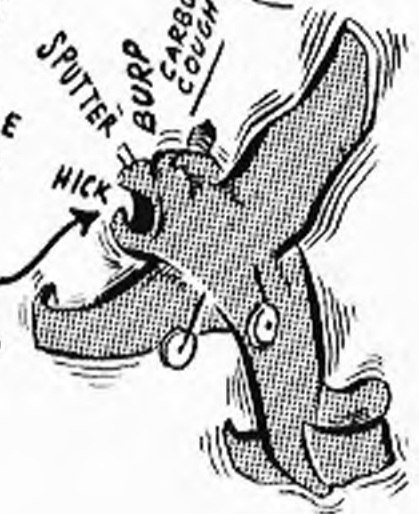
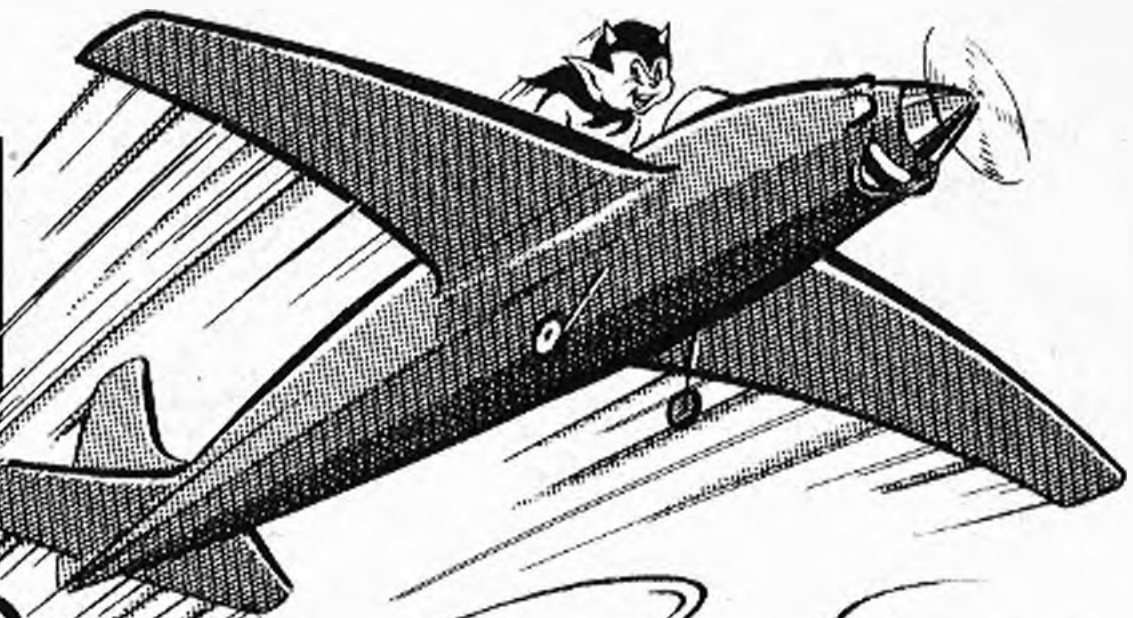

"I USE SPUTTER-JUICE... WITH CARBON, GUE AND AMYL ACETATE!"

"HOT OR COLD, I'M 'ACLIMATED'?"

"GROAN... GOU AND CASTOR OIL"

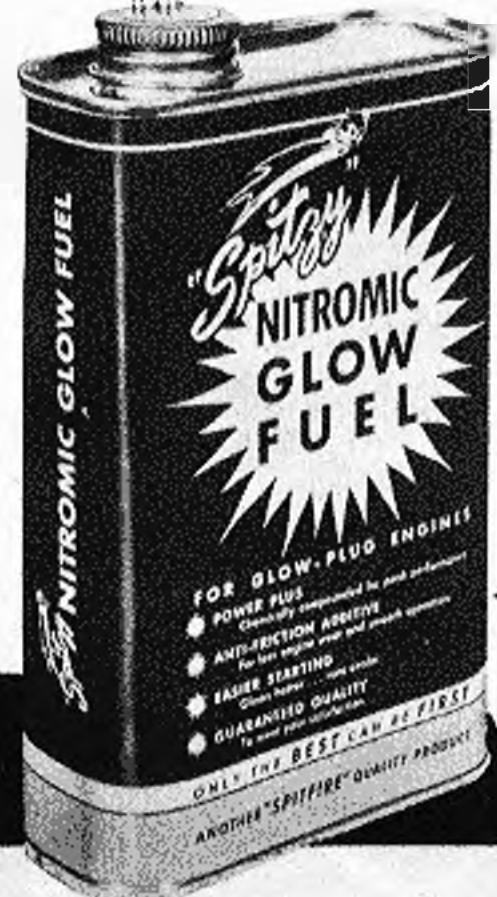

**IT STILL GOES... \$500.00 REWARD**  
 ...For any glow fuel formula that will out-perform "SPITZY" NITROMIC GLOW FUELS! All offers subject to our inspection and approval. Any fuel formula accepted will become the property of the Mel Anderson Mfg. Co.

**Use NITROMIC POWER for LEADERSHIP — for CHAMPIONSHIPS— for QUALITY — for Carbon Free, Smooth, PEAK PERFORMANCE.**

**SPEAKING of CHAMPIONS—"Spitzy" NITROMIC has flooded the flight lines of more than 60 A.M.A. Authorized Contests in 1951 — The list of champions is too large for publication.**

**ONLY 85¢ FOR A FULL PINT OF POWER**

It is not acimated. The weather—it's temperatura and resulting relative humidity is the work of the suprema being. We don't pretend to control the weather. WE ARE FUEL MEN NOT WEATHER MEN.

**CLEANS AS IT RUNS**

**MEL ANDERSON Manufacturing Co.**  
 1518 THIRD AVE., LOS ANGELES, CALIF.

a new  
plastic  
bonding  
agent



410M  
**PLASTICATE**

**BEATS GLUE** for model  
assembling and repairs.

never lets go

410M Plasticate is a fast drying adhesive that sticks to any surface — wood, paper, ceramics, cloth, leather, cork, concrete, plaster, brick, masonite, etc. It joins parts with a bond of 2500 pounds per square inch. Once set, it will never let go. Won't peel, crack, crystalize, or decompose. Defies shock, moisture, solvents. This is the most permanent bonding agent in the model building industry.

easy to use

410M Plasticate spreads on with a brush, stick or finger, clean to use. Dries quickly, and transparent. No waste, no mess. Any excess may be wiped off. Makes an ideal bonding agent with plaster patch.

Large 48 c.c. jar . . . only

**35¢**

**410M PLASTICATE**

is participating in the All-American Model Airplane Contest. See contest details on other pages of this magazine.

Get 410M Plasticate where you buy your parts and materials.

**stewart/lundahl co.**

7349 Coldwater Canyon, North Hollywood, Calif.

remove, so that the cement marked the side where it came in contact with the keel and bulkheads. Should the side not pull down tightly, dip a paint brush in water and wet those spots.

If you make an engine and tank hatch, which we recommend, you can put on the right side of the body before putting on the stabilizer and rudder. Handle it the same as the first side, cementing up to and including the firewall. When the cement is dry, cut the front section off at the firewall and use that section for the hatch covering. In making the hatch, we found it easiest to make two half plywood bulkheads the same size as the right half of the firewall and F-2 bulkhead. We also cut the nose block in half at the keel. By cementing these into position on the hatch cover previously cut off so they would slide in just ahead of the firewall and F-2 bulkhead, we held the sheeting rigidly in place. After this hatch cover was cut out to receive the engine, we covered both the hatch and the left side of the nose with Silkspar for strength. The hatch can be held in place by making a plywood disc fitting the nose of the plane and cementing only to the front of the hatch; two small screws into the left side will hold it in place. Drill oversize holes for these screws and set them in cement, not just in the balsa. Small screws at an angle at the back of the hatch and into the firewall can be used to hold in rear.

This ship is set up to fly counter-clockwise. If you are a clockwise flyer, offset the wing on the opposite side (it is an unbalanced wing), reverse the bellcrank, lead-outs, outboard weight, offset of engine, control horn, pushrod, rudder, tank, hatch.

Our Senior came through the AMA stunt pattern with flying colors and held like a veteran in the overhead eights, the acid test of any stunt ship. It looks nifty too—trim lines, realistic in flight, particularly without the landing gear.

### Ringmaster

(Continued from page 24)

edge may be added. The hard wood bellcrank mounting block should be drilled and fitted between the center ribs. Install the bellcrank, pushrod and run the lead-out wires through the left half.

Complete the I-beam spar at this point by adding 1/16" sheet balsa compression members between the upper and lower spars and snugly between the ribs. Cover the leading edges and center section with 1/16" soft balsa and carve the tips from solid blocks. Hollow the left tip only and cement both tips in place after running the lead-out wires through the aluminum tubing.

**Rudder, Stabilizer and Elevators:** The rudder and fairing are cut from 3/16" medium balsa and sanded to shape. Stab and elevators are made of 1/4" sheet balsa and shaped to a symmetrical section. The .040-dia. wire control horn is formed and cemented to each elevator half and the hardwood strip, with silk or aircraft fabric cemented over it.

**Fuselage Assembly:** Cut out all the formers required and bend the landing gear from 1/8" wire. Assemble the landing gear to the firewall and begin the final assembly by slipping the fuselage sides on the wing, as shown in the sketches. Bring the two sides in and slip the firewall and former #4 between them. Center the fuselage on the wing and cement together. Lay the structure on a flat surface and allow to dry.

Now, add the plywood nose ring, #1 and the remainder of the fuselage formers, slipping them over the pushrod and at the same time adding the plywood fair-lead to former #5. Locate your engine in the nose, drill out the mounting holes and solder four nuts to tin-can metal and cement these to the underside of the mounts. The fuselage is now planked, the sheet bottom added and the nose and cowl blocks carved and fitted in place. The cowl should be hollowed to suit your particular engine and gas tank installation.

Lay the stab and elevator assembly in place on the rear of the fuselage and solder the pushrod to the control horn. Check the con-

## Super Detail World War I

1/2 INCH SCALE FLYING MODELS

DESIGNED FOR CAMBUS CO2 OR RUBBER POWER

SOPWITH CAMEL  
SPAN 14" \$1.00



OTHERS AVAILABLE IN THIS SERIES

SESA SPAN 13 5/16" \$1.00

ASK YOUR  
DEALER FIRST

POKKER DRI SPAN 11 3/4" \$1.00

If Ordered Direct Please Add 10c Postage

**CARTER CRAFT MODELS**

16 MONTICELLO ARCADE NORFOLK 10, VIRGINIA

**RADIO CONTROL**  
On the  
**CITIZENS BAND**

The Only  
**LICENSE FREE**  
Radio Control

**Citizen Ship**

1st Place  
Winner at 1950 Nationals

**FACTORY ADJUSTED** for permanent, trouble free performance.  
**READY TO OPERATE**—No technical knowledge required.  
Escapement available.

**TRANSMITTER** completely self con- \$39.75  
tained; price less batteries.....

**RECEIVER** factory tuned precision unit, \$39.75  
built in antenna; less batteries.....

\*No operator's or amateur license or examination required.  
Station license application packed with transmitter; just mail to nearest FCC office.

See your dealer first . . . or write  
**VERNON C. MacNABB CO.**  
909 Westfield Blvd. Indianapolis 20, Ind.

**LENS HOUNDS** \$10 awaits lucky contributor who sends in best picture each month for Air Ways. Glossy prints, 4" x 5" min. One year subscription awarded next two runner ups. Mail pictures to: Photo Editor, Model Airplane News, 551 Fifth Ave., New York 17, N. Y.

★ ★ ★ ★ ★

Our 510th Advertisement  
**REAL DIESEL ENGINE!** ★

**\$2.95** ★  
You can't beat this price! ★

★ Ideal for planes, boats, model cars ★  
★ Actually runs at 2800 RPM. produces 1/7 HP ★  
★ Maint a full 3 1/2 inches; weight 5 ounces ★  
★ Comes completely assembled, ready for operation ★

★ **MAKES WE'RE CRAZY**, giving away a precision diesel engine, complete with cylinder and piston, crankshaft, connecting rod, etc., for ONLY \$2.95. But we're selling thousands of DEZZIEs all over the world, and that keeps our production costs down. DEZZIE is streamlined, compact, rugged, starts quickly, easy to install, runs for years! Fast delivery if you ORDER DEZZIE today! ★

★ **SEND \$2.95 plus 25c postage** ★  
★ **GOTHAM HOBBY CORP.** ★  
★ 107 E. 124th St., New York 35, N. Y. ★

trials for freedom and sufficient movement. The stab is securely cemented to the fuselage and the rudder and fairing added. Sand the fuselage industriously and cover the entire ship with Silkspar or silk. The cowl alignment pins should be located and installed in addition to the cowl hold-down bolt.

Make the tank from .008 thick shim brass as shown on the drawings or select a commercial tank of the correct size. The tank is held in place with wood screws as shown on the drawings. For appearance, wheel pants and gear fairings are hard to beat. Properly made and installed, they will take a lot of contest punishment and still add sparkle and class to the old wagon.

**Finishing:** Two coats of wood filler with a fine sanding between coats will enhance the beauty of your version. Several coats of colored dope will give a light and durable finish. Cement a bubble canopy of generous size over the cockpit and fair the edges with a strip of silk. To simplify our trimming problem we chose Hobby Decal Checkerboard with Trim Film stripes. Two coats of Stanzel's Tuff hot-fuel proofer were used to protect the finish. The original ship sports a black-and-white paint job with red plastic spinner and trim.

**Flying:** The model should balance near the wing spar and requires about one ounce of weight in the right wing tip. Initial flights may be attempted on .012 dia., 52' lines that are lengthened to 63' for all-out air work.

## Sweden Wins Wakefield

(Continued from page 27)

some most interesting new design trends.

The long fuselage designs—which accommodate single skein motors 50 to 55 in. apart between hooks when unwound—have tremendous possibilities for real still air flying. They are just that bit inclined to get upset in turbulent air however which can pull the overall flight time right down. But for normal rate of climb, and particularly glide performance, they impressed everyone with an experienced eye. In fact, reports of phenomenal glides on the evening before the contest led to a most involved argument amongst some other nationals as to whether or not it was optical illusion on account of the size of the fuselage! It seemed impossible that any Wakefield should glide so flat and sink so slowly!

There was also another very interesting point about the American models. Foster's 60 in. fuselage job, for example, had a complete structural weight (including prop) of only 90 grams, which many other modellers found difficult to believe. Fuselage was 1/8 sq. with Warren-girder 1/8 x 1/16 bracing, and most other spar sizes 'normal.' A European airframe built to similar specification could be expected to weigh at least fifty per cent more.

Taking into account the fact that Foster is an indoor builder, and therefore a real expert in lightweight construction, there is still a margin of weight to be accounted for. This, almost undoubtedly, is in the density of the balsa wood available in America. For the same strength the American modeller can undoubtedly obtain lighter wood of the same overall dimensions.

This can be a great advantage next year. The 1951 American team more or less designed their '1952' model on the way back to England in the airplane. It is to have a long fuselage, but with the motor terminating about two thirds of the way back. To get a long motor, and use it taut between hooks return gears are called for. The long rear fuselage, virtually a tall boom, will make it possible to use a small stabilizer area and get more into the wings. In other words, the '1952 design' is 'combine the best features of the return gear model (which at present averages about 39 in. fuselage length) and the long fuselage single skein job.

American modellers can take the credit for having the courage to produce the very long fuselage Wakefield and show that it really can work. It has set a lot of people thinking on the other side of the Atlantic now. The first mention of return gears, too, came in an early Ziac's Yearbook, although Ellis must take the credit for having emphasized their worth in winning the Wakefield two years

# ATTENTION Control Line Flyers!

## Fly the NEW FOX 59!

- LIGHTER WEIGHT
- QUICKER STARTING
- GREATER POWER
- SMOOTHER RUNNING
- PERFECTED CARBURATION

Experience for yourself the tremendous thrill of vastly superior motor performance!



\$29.95 at your Hobby Shop

FOX 59 performance will enable you to complete your pattern with the snap and precision that bring top points. With new confidence you will improvise new and more difficult maneuvers... secure in your knowledge that FOX will pull you through!

By the makers of the famous . . .

- FOX 35** - Winner of ALL FIRSTS in 1950 National Stunt Event; winner of hundreds of stunt contests throughout the country this past year. \$14.95
- FOX 29R** - World's Record Team Race Holder . . . Outstanding Racing performance. \$16.50
- FOX 29** - Finest in 29 Stunt and Free Flight performance. \$14.95

### ARNOLD & FOX ENGINEERING CO.

7401 VARNA AVENUE, NORTH HOLLYWOOD, CALIFORNIA

running. An American model at least justified itself this year in placing fifth and the subject is one which is currently receiving a lot of attention in England. Unfortunately two of the leading British 'gear-proponents' did not make the 1951 team and so it is really impossible to judge their respective merits. All the data available, however, points to the fact that a motor taut between hooks is superior to one which is corded or spring tensioned—and the only way to get a long motor in a reasonable fuselage length and keep it taut between hooks is with return gears.

There is plenty of food for thought in the design of 1952 Wakefields and it seems that the real need now is not for a five minute still air model but a high-time model which will produce a consistent performance in still air and winds, with no appreciable thermal assistance. That, it appears, is going to call for fast prolonged climbs followed by a really good glide, but not so near the stall that turbulent air can upset it. All the European contestants will be looking forward with real interest to see how American designers are going to produce the answers to those questions for the 1952 contest in Sweden.

#### Weather summary:

First round, starting 7:30 p.m.  
Calm to 100 ft., slightly turbulent air above, with drift 4-5 m.p.h. Slight but appreciable 'lift' at good heights.

Second round, starting 9 p.m.  
Similar wind conditions, cooler, no appreciable 'lift.' Dampness setting in, but not excessive.

Third round, starting 3 a.m.  
Overcast sky, windy—15-20 m.p.h. at 100 ft. and above.

#### Model designs:

Almost exclusively slabsider. No startling design trends, except for American models. Diamond and rectangular section about equally favoured. Fuselage lengths slightly longer, on average, than 1950. A fair proportion of modellers used gears, but not as many as anticipated. More folding propellers than freewheelers, but higher proportion of freewheelers in the top places. Very few examples of feathering propellers. END

# WYLAM MASTERPLANS

## BOOKS II & III OFFERED IN COMBINATOR FOR ONLY \$3

These two treasured volumes are packed with super-detailed drawings to guide you in constructing "real jewels" in miniature aircraft. Years of patient research were spent before these drawings were possible.

### CONTENTS

BOOK II	BOOK III
Weightless Orig. Flyer	Albatross D-1 to D-6
Racing B-29 Superfort	Hell P-63A Kingcobra
Bell P-59A Airacomet	Boeing C-97 Strato.
Northrop A-17A	Beistal F2H Bratfit
Lycoming R-680 Engine	De Havilland Deltic
Northrop Black Widow	Douglas A-26 Invader
Martin A-29 Maryland	Douglas C-54 Skymaster
Republic Thunderbolt	Hispano-Suiza Engines
Martin B-26H Marauder	Lewis .30 AA Mach. Gun
Vought Vindicator	McDonnell XP-67
Avro Lancaster I	Piper PA-8 Skycycle
Ale Bombs	S.E.-5 Color Scheme
Consol. B-24H Liberator	Details
Boring B-17G Fly. Fort	S.E.-5 R.A.F. Markings
Fokker G-1	Selmon-Haska Engine
N. Amer. P-51B Mustang	Selmon-Schubert D-4
World War I S.E.-5	Spad S-VII
Mitsubishi GR-01 Betty	Spad S-XII-2
Consolidated Catalina	Spad S-XIII C.1
Curtis P-40 Warhawk	Vickers .30 and 11 mm
Grumman F6F-3 Hellcat	Machine Guns
Curtis A-25 Helldiver	Vultee XP-54

#### AIR AGE, INC.

551 FIFTH AVE., New York 17, N. Y.

Enclosed find \$.....Send me:

- ( ) Combo. Offer Books II & III.....\$3.00
- ( ) Book II .....\$1.50
- ( ) Book III .....\$2.00

NAME .....

ADDRESS .....

CITY..... STATE.....



**A SOOPER-DOOPER T-BONE!**

## ACE "T" ROD

Get this really EASY-TO-BUILD scale model of the stripped down, souped up "T" Rod. Even youngsters can put it together quickly. Simplified parts, mostly ready-shaped, with instructions—packed in an attractive box for only 60c a kit. Get yours today!

Famous ACE "T" ROD KIT No. 3R

KIT COMPLETE  
**60¢**

AT ALL MODEL AND HOBBY SHOPS



### CUSTOM MADE ENGINE WRENCHES

For nuts, bolts and screws on all popular engines

*Made of annealed spring steel  
Rockwell tempered  
Cadmium plated*

A compact set of small tools for model planes, boats and race cars

HANDY IN THE WORKSHOP TOO

EVERY TOOL GUARANTEED  
MONEY REFUNDED IF NOT SATISFIED

**\$1.00 PER SET - POSTPAID**

No C.O.D.'s Please

The Duncan Craftsmen - Atlantic, Pa.

## Buy Where You Find THIS SEAL



**IT ASSURES YOU THE BEST AND NEWEST... plus FRIENDLY SERVICE**

### FLYING HELICOPTER MODELS



#### GAS — RUBBER — JET

All kits complete. 60c refunded with first order. Write for catalog.

AERO-TECH 601 Jefferson Street  
Montgomery, Alabama



Don't miss the sensational  
**NEW Model of Models!**

# SMARTY



1/2 A Free Flight

AT YOUR DEALERS NOW!

SOUTHLAND MODELS

P. O. BOX 2721

GREENSBORO, N. C.

## Fokker E-1

(Continued from page 38)

haust gases could be expelled and to provide a minimum chance of accumulating inflammable liquids. It was attached by a double steel wire "strap" which ran the circumference of the cowl and was buckled to fittings on the front end of the lower longerons. The flat sides of the fuselage immediately behind the cowl were aluminum covered to about the middle of the cockpit. The circular form of the engine cowling was diminished to flat, by formed sheet aluminum skirts extending from the rear of the cowl to the leading edge of the wing. These members were detachable and had access doors where needed.

Fokkers E-II and E-III both were armed with a single air-cooled Spandau machine gun. This weapon was mounted in front of the pilot to the right of the ship's vertical center line. Ring and bead gunsights were used.

Behind the engine was a divided tank, one partition containing castor oil, the other serving as a gravity-fed auxiliary tank. The main fuel tank was located behind the pilot, provided with a filler cap about flush with the top fuselage surface, and a drain cock at the bottom. This was a cylindrical tank which fit sideways in the fuselage. Fuel from this tank was fed to the engine under air pressure provided by mechanical and hand-operated pumps. Mechanical air pumps were both engine driven and wind-driven; the hand pump was of the fill-gun variety and used for emergency air pressure. An intricate plumbing system of air pressure and fuel lines kept the engine running—most of the time. Ignition was provided by an engine-driven magneto according to the custom of the time.

Instrumentation generally was poor on all W. W. I German airplanes. The Fokker E-II and E-III were no exceptions. No airspeed indicator was fitted. Neither was there an instrument panel, as such. A plywood board at the pilot's right carried the fuel flow vial, air pressure gauge, controls for the mechanical or manual air pressure lines and the throttle valve off-on control. In front of the pilot was the ammunition belt full- and empty-box (spent cartridges were dropped from the plane) with an access door to permit loading from the cockpit. The door also doubled for a map holder—these planes still were primarily reconnaissance scouts.

To the pilot's left, attached to structure, were an oil gauge and an altimeter. Near the floor on his right was the manual air pressure pump. The control stick head had two fore and aft horizontal handles to be gripped by either or both hands, and thumb-operated machine gun trigger and "contact" button. The pilot's seat was a formed aluminum bucket affair attached to the fuselage by steel tubes and adjustable vertically.

**Landing gear**—This member was a rather complicated maze of struts which served the double purpose of supporting the main wheels and at the same time incorporating the lower anchorage structure to which the wire wing racing was attached. Details can best be obtained from the accompanying drawings and photographs. The tail skid was sprung on rubber cord, and the skid arm pivoted on an inverted pylon of steel tube struts which also served as a support for the horizontal stabilizer.

**Empennage**—Throughout Fokker's designs, we find the mark of a man interested in solving production problems the easy, practical way. That is why he used a variety of materials in his planes—the best material for the specific purpose. Fokker E-II and E-III tail assemblies were identical. Steel tubing, welded together, was used exclusively. These members were aerodynamically balanced and fabric covered. The rudder was "comma"-shaped, and the elevator trapezoidal. There were no fixed empennage members.

**Wing structure**—Wings were of constant chord and with positively raked tips, giving a greater span at the trailing edge than at the leading edge. This was to provide

(Continued on page 50)

# the truth about dope!



**WHY PAY MORE THAN COMET'S  
LOW PRICE** for a Generous Bottle of Quality  
Dope—Used with Complete Satisfaction by  
Model Builders for Many Years—and Perfected  
by America's Largest Manufacturer of Model  
Airplane Kits!

**COMET** *Top Quality*  
**DOPE** *for only* **10¢**

## THE TRUEST COLORS!

No colors brighter—no colors truer! Vivid, up-to-the-minute colors like Insignia Blue and Red, Regal Maroon, Aeronca Orange, Taylorcraft Yellow—and a full range of the colors you want for your newest models! And a big bottle for only 10c!

## AMAZING COVERING CAPACITY!

Comet Dope covers like no other! Flows on smoothly, dries quickly, makes models look better! And a big bottle for only 10c!

## REMARKABLE RESISTANCE TO SEPARATION and HARDENING!

A good dope—stays good in the jar! These are the features you want—and you find them in COMET DOPE—in a generous-sized bottle for only 10c!

Send 10c for illustrated catalog sheet showing full line of Comet models, complete list of colors in Comet Dope, etc.

**COMET MODEL HOBBYCRAFT, INC.**  
129 WEST 29th STREET • CHICAGO 16, ILLINOIS

**COMET  
CEMENT 10c**  
Another top value



## INSIST ON PERFECT TANKS

They're light . . . clean . . . soldered inside and out. And they're good to the last drop of fuel. PERFECT Tanks are 100% hot-fuel proof . . . in all sizes. Ask your dealer for PERFECT Tanks. Don't accept inferior substitutes.

**Buy-Word of Satisfaction**



KRAMER BROTHERS Baltimore 2, Md.  
KRAMER BROTHERS Newark 2, N. J.  
NATIONAL MODEL DISTRIB. Chicago 14, Ill.  
MAXWELL MODEL SUPPLY CO. Los Ang. 15, Cal.

## FULL-SIZE PLANS

GEE BEE, pg. 33 & RINGMASTER, pg. 25

BOTH PLANS FOR 25c

Also Available —

### CUBEE

A realistic low-wing twin-float seaplane for engines of .045 to .09 disp. (Sept. '51 issue.)

### WAGTAIL

A stuntable scale model of a famous World War I fighter; for .09 engines (Sept. '51 issue.)

BOTH PLANS FOR 25c

With the Sept. issue we began a Full-Size Plan Service on our featured model designs. Orders filled immediately and mailed out via 3rd Class Mail unless otherwise specified. For First Class postage add 6c and for Air Mail add 12c, for each set of two plans.

### MODEL AIRPLANE NEWS PLAN DEPT.

551 Fifth Ave., New York 17, N. Y.

Enclosed is 25c for full-size plans of "Gee Bee" & "Ringmaster."

Also 25c for full-size plans of "Cubee" and "Wagtail."

Name (please print)

Address

City Zone State

greater flexibility along the trailing edge, thus giving effectiveness to the wing-warping method of lateral control used.

Spanwise members of the E-II and E-III wing were the two spars made of ash, milled out to an "I" section. Ribs were made of poplar. Leading and trailing edges were of wood. Inter-spar bracing consisted of steel tube compression members and cross-bracing of steel wire. Wing tips also were made of thin wood, cut and formed to provide the proper flexibility demanded by a wing-warp lateral control system. The wing was made in two pieces with thirteen ribs on each side, including the stub rib.

Wings were braced by a total of sixteen cables—eight top and eight bottom consisting of: eight top and bottom attached to the leading spar permanently, and eight top and bottom attached to the rear spar. The latter were run through a pulley on the overhead pylon, continuing beneath the wing to a system of control horns attached to the rear of the landing gear. The forward spar cables, permanently attached to the overhead pylon, or cabane, continued on the underside to the forward part of the landing gear. Examination of the drawings will make this clear.

In addition to the cables, the right and left wing spar panels were attached to the fuselage by tubular fittings, which also served to expedite transport in a disassembled condition. For some reason, the Germans did not fly their aircraft from factory to front line squadrons, but depended on motor trucking, railroad flatcar, or towing behind a light truck. Accordingly, all their planes throughout W. W. I were easily taken down, and were designed to meet these transportation specifications.

Performance—While the Fokker E-II and E-III proved valuable to the German Air Service, their success was largely due to the fact that they had no opposition. In terms of combat specifications that eventually were developed, they were notoriously weak. They simply were not designed for combat flying! Early victories made on these Fokker monoplanes by the early German aces were simply a matter of flying up behind an unsuspecting enemy and letting him have a burst from the still "secret" synchronized machine gun mechanism. Actually, the E-II and E-III were not capable of prolonged power dives; their air endurance was limited to about 1½ hours, and their speeds were low. Top speed of the E-II and E-III varied from 88 to 90 mph. Their rate of climb and ceiling were little improved over the E-I but nevertheless, men like Boelcke, Immelman and Udet were able to exact terrific tolls of the unprepared enemy.

It is interesting for historical and military aviation students to note that once the Allies perfected the synchronized machine gun, the odds became even and the actual airplane design proved the deciding factor. That is the point at which Germany lost her advantage and the rudiments of scientific air-warfare were born.

As far as flying ability was concerned, the Fokkers E-II and E-III had it. Wing warping permitted "hands-off" flight because they were properly designed in the first place to include the characteristic of inherent stability. In the maneuverability category, they were very good. Lightly loaded—for the time—they were stunters of the first water, based on Fokker's 1913-1914 "looping monoplane designs." They took off very quickly, and landed slowly—about like a Cub.

But their structural strength still is a matter of question, historically. It still has not been definitely determined whether Lt. Max Immelman was killed in a Fokker E-III because of: 1. being shot down by the R.F.C.'s Hawker; 2. being hit by an artillery shell; 3. because he overstrained his ship and structural failure resulted.

Whatever the cause of his demise, it can be said that Immelman was the greatest exponent of the Fokker monoplane the German Air Service had to offer. Whatever performance qualities it had he used to the best advantage in gaining his victories.

The Fokker E-IV was Fokker's attempt

to compete with the Albatros D.I, which seemed to be favored by a supply of Mercedes 160 hp motors. Historically, Fokker was unable to get the 160 Mercedes, and he equaled the power by utilizing the Oberursel U III, 160 hp rotary engine. This was a 14 cylinder engine, made up of two banks of 7 cylinders, and the fore-runner of our modern twin-row radials. He designed an airplane a bit larger than the E-II and E-III, called it the E-IV. But the E-IV Fokker was more than just a development in the line. Immelman's success on previous types led authorities to demand from Fokker a "super plane" specifically for Immelman. The original E-IV was noteworthy for its battery of three Spandau machine guns.

Immelmann's E-IV proved unlucky for him although he gained two victories on it. On one occasion, the synchronizing gear went out of whack and he shot off his propeller. The vibration shook loose his engine, except for one oil line, which prevented it from dropping completely out of the plane. Fortunately he landed safely in this condition, but never flew the ship again. He was killed in a Fokker E-III.

The E-IV design, however, reached limited production and was built as the first, or one of the first two-machine gun pursuits. With the 160 Oberursel it attempted to compete with the 160 hp (Mercedes) Albatros D.I, but the advance of the latter was too great. Very few Fokker E-IVs were built.

E-IV wing span was 33 ft. even; length over all was 24 ft. 10 in. Bare weight was 1025 lbs. and weight loaded was 1,590 lbs. High speed at sea level was 90 mph, and rate of climb 3,300 ft. in three minutes; 6,600 ft. in eight minutes; 9,000 ft. in fifteen minutes and 13,200 ft. in twenty-five minutes.

Perhaps there should be some sort of permanent legend around the 1918 Fokker monoplanes. There certainly was a legend about them when they were in their prime. To them can be attributed the foundation of aerial warfare as the basis for today's tactics.

And because of the Fokker monoplane, Allied designers were forced to design better planes to counteract it. Actually, Fokker's synchronized machine gun was the trick that turned the tide. If the Fokker monoplanes are remembered for no other reason, it will be because they changed the thought of many armament engineers and aircraft designers from an idea to a concept.

## Pen-Pals

J. Backwell, 57 Maude St., Geelong, Victoria, Australia, would like to write to anyone interested in all types of free flight models . . . David G. Batty, 216 Stanley Rd., Wakefield, Yorkshire, England, wants to correspond with someone who likes flying scale models, both free flight and control line; he is also willing to swap an English Diesel engine . . . Jaime Fabrega, Box 195, Panama, Rep. of Panama, wants to hear from modelers who prefer stunt flying . . . Rick Tomkins, 33 Redthorn Grove, Stechford, Birmingham 9, England, wonders if he can swap views with someone favoring power models . . . P. Shield, 13 Elmore Rd., and J. Moseley, 4 Acacia Rd., both of Enfield, Middlesex, England, want to exchange magazines, kits and plans.

EXCHANGE MOTORS: Jere Allnoch, Box 5179, N.G.C., Dahlonaga, Ga., wants any A or B motor in fair condition in exchange for an .039 Cub engine and Scientific Little Devil . . . Joseph Celea, 203 May Ave., Collins Pk., New Castle, Del., wants to trade his O & R 23 for an .074 or .099 engine . . . Noble and Donald Glandell, 4541 No. St. Louis Ave., Chicago 28, Ill., have a ½ A O.K. Cub, O & R 23 and .19 which they want to trade for an old Class A airplane motor, not larger in displacement than .200, or an .074, .099, or .189 motor . . . Billy Nelson, Box 203, Gibsonville, N. C., wants to exchange a Baby Spitfire .045 for a Cub .074 . . . Arnold Nowell, 23 Williams Ave., Hyde Park, Mass., has been searching for a Campus A-100 . . . George Thrift, 1632 Wilkins Ave., Baltimore 23, Md., would like to exchange a Dennykite (60) for a McCoy Baby Mac, .09 or 19.

**NOW...**

**For The First Time**

**EVERYTHING YOU NEED for MODELING**

**ON  
CREDIT  
NO CARRYING CHARGES**

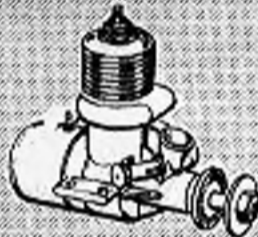
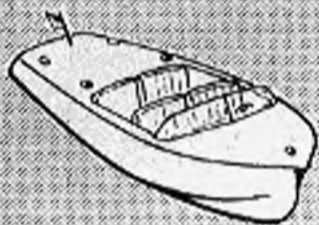

**ACCESSORIES**

**USE  
YOUR  
CREDIT  
ORDER NOW**  
or send for illustrated  
CATALOGUE  
over 5000 items  
only **25c**

**ANY NATIONALLY ADVERTISED HOBBY PRODUCT . . .  
AT NATIONALLY ADVERTISED PRICES . . . ON CREDIT!**

Now . . . You no longer need cash to follow your Hobby . . . Buy now on Credit, and Pay as you Build!

- MODEL AIRPLANE KITS, U-CONTROL, FREE-FLIGHT •
- ENGINES • BOATS • MINIATURE RACE CARS •
- DOPES • FUEL • PROPS • ACCESSORIES • etc.

Order what you need . . . ANY NATIONALLY ADVERTISED PRODUCT in this magazine, subject to prior order. Pay only 40% cash with your order . . . Pay balance as scheduled below. **USE YOUR CREDIT . . . IT'S YOUR GREATEST ASSET!**

**KIDS** . . . If you are under 21 have Dad, Mom, or your legal guardian sign for you. Pay them back out of your weekly allowance. Get them to tell you how credit works. Credit is something everyone should have and learn to use. Buy that airplane or engine and pay for it the way Dad pays for his car. **PAY AS YOU BUILD.**

**ORDERING INSTRUCTIONS** . . . Write your order on a separate piece of paper and enclose 40% down payment (preferably check or money order) with this signed coupon to receive proper credit recognition. To speed delivery, please give full details, such as . . . Price, name, brand, manufacturer's name and address, size, color, and any other information that will enable us to send you exactly what you want. We reserve the right to refuse any order.

**HOBBIES-Toys of Hollywood**

**P. O. Box 591, Hollywood 28, California**

I certify that I am 21 years of age, employed and will sign a conditional sales agreement to cover the balance due on the items I have purchased.

**NAME** \_\_\_\_\_

PLEASE PRINT CLEARLY

**ADDRESS** \_\_\_\_\_

**CITY** \_\_\_\_\_ **ZONE** \_\_\_\_\_ **STATE** \_\_\_\_\_

**SIGNATURE** \_\_\_\_\_

**PAYMENT SCHEDULE**

Amount of Purchase	Down Payment 40% of Total Purchase	Weekly Payments
\$ 5.00	\$2.00	\$ .50
7.50	3.00	.75
10.00	4.00	1.00
15.00	6.00	1.50
20.00	8.00	2.00

Credit limit \$30.00 unless by special arrangement  
F. O. B. Hollywood, Calif.  
No Credit outside the U.S.A.



Now, You Too, Can Own A

# STUTZ Bearcat!

Measures 10' 1/2" in length when completed



1914 Stutz Bearcat — \$195

It's Easy! No Fuel! No Oil! No Battery! That's the New Hobby! It's Country! Easy to Build! Collectible! Miniature! Airplane! Auto! Models! In 1/2" Scale!

In a few hours you can build this fabulous STUTZ Bearcat in miniature! Not only the complete car, but 14 other famous antique models and parts to build and enjoy! It's easy to build! If you have our built-in "Old Timer" yet, you are getting a big thrill! Each one is exquisitely detailed. The parts included are included ready-to-ship for you. You can buy them by mail or in person. They are billed by express. When complete, they are perfect for your desk or library. Entry card-sets are large and attractively lettered. Satisfaction guaranteed. At hobby toy and department stores.

1901 Stanley Steamer	\$12.95
1904 Olds	\$1.95
1911 Buick	\$2.50
1902 "A" Ford	\$2.50
1909 "T" Ford	\$2.95
1903 Cadillac	\$2.50
1900 Packard	\$2.50
1903 Rambler	\$2.50
1902 Franklin	\$2.50
1910 Inler, Haverstar	\$2.14
1913 Mercer Raceabout	\$3.95
1911 Maxwell	\$2.50
1906 "Old 16" Loco.	\$3.95

With us too. Add 15c for postage handling. No C. O. D.'s please.

**HUDSON MINIATURES OLD TIMERS**  
"Originators of Antique Autos in Miniature"  
SCRANTON HOBBY CENTER, Dept. 16, Scranton 10, Pa.

## NEW MOTORS FOR OLD!

Trade-in one of your old motors (any make, any condition) for 1/4 the price of any new motor up to \$20.00. See motor manufacturers ads for prices, we stock 'em all!

**FREE!** Brand new Fox 35 with Vernon MacNabb citizenship radio control.

Transmitter	\$39.75
Receiver	39.75
Fox 35	14.95

Regular \$94.45 value, plus extra bonus gift of 12 six-pitch propellers all for our special combo price, only \$79.50 P.P.

**FREE!** 12 propellers with every new motor. Your choice of sizes: 6 x 3, 6 x 4, 7 x 3, 7 x 4, 7 x 6, 8 x 4, 8 x 6, 8 x 8, 9 x 4, 9 x 6, 9 x 8, 10 x 4, 10 x 6, and 10 x 8. (Not included if you claim trade-in allowance.)

Pre-paid orders shipped postpaid, or send \$1.00—we ship C.O.D. for balance and postal charges.

These offers available only from:

**ALL AMERICAN MODEL MOTOR EXCHANGE**  
Dept. M, Box 885, Santa Monica, California

## PAL "55"

FOR SMOOTHNESS AND POWER

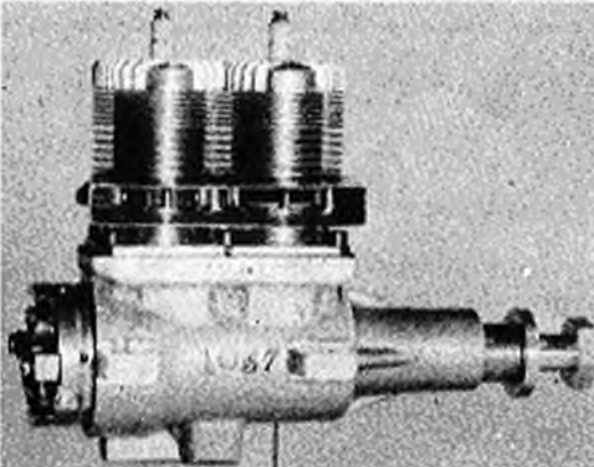

Weight 15 oz. Displacement .55 cu. in.

**\$62.50** Ignition & Glow Plug **\$49.50** Glow Plug Only

DEALER INQUIRIES INVITED

**PAL ENGINEERING LTD.**  
53 16TH AVE. S.W., CEDAR RAPIDS, IOWA

## AMA News

(Continued from page 30)

occurs for which the club is liable or allegedly liable?

Answer: Yes. Individual members may be held financially responsible and are protected by the policy.

3. Does the policy pay investigation and legal costs?

Answer: Yes; the policy pays all costs of investigation of claims presented, together with any legal expense, and pays this in addition to the policy limit.

4. What are the policy exclusions?

Answer: The policy does not cover operation of motor vehicles (other than model aircraft), injuries to employees (Workmen's Compensation Insurance), structural alterations or new construction, liability assumed under contract or agreement, unless the policy is specifically endorsed. Also water damage, property in the care, custody, control, or owned by the club or members thereof.

5. Would the Insurance Company pay anyone injured?

Answer: Not necessarily. It depends upon the circumstances which are based on the Law of Negligence. When a claim is presented, notification should be given to our office, at which time a thorough investigation will be made by the Company. If responsibility for the accident is shown to rest with the club, the company would proceed to make a fair settlement. If this is not shown by their investigation, full cost of defense, including any court trial expense, is provided by the company.

6. Does the insurance cover claims arising out of accidents to spectators or passers-by?

Answer: Yes. (As discussed under No. 5).

7. Would it cover claim made by a spectator for damage to his automobile allegedly resulting from a club or chapter activity?

Answer: Yes. The policy would protect the insured group as outlined under No. 5.

8. Should the club or chapter buy high limits?

Answer: Yes, it is always advisable to carry high limits of legal liability protection—the additional cost is small—and verdicts are more and more generous.

Groups already AMA Chartered should write directly to Heber Smith Morris, corner Pitt and Cameron Sts., Alexandria, Va., for additional information. To have your group chartered, write to AMA, 1025 Connecticut Ave., Washington 6, D. C.

**NATIONAL AMA RECORDS ESTABLISHED.** Gas Models, Controllable Speed, Class C Open—132.30 mph. Record established by Robert L. Cowles, Jr., Green Bay, Wis., on July 1, 1951 using a McCoy 49 powered Half Razor. Prop used was a Rev-Up 9D x 11P thin blade.

Towline Gliders, Class D Open—21:09.0. Record established by John Dooley, Crossville, Tenn., on June 23, 1951, using a Jasco Floater.

Outdoor Unlimited Rubber Models, Junior—3:39.2. Record established on June 24, 1951 by James Joseph Zimmerman, Cedar Rapids, Iowa, using a High Performance Sportster designed by C. R. Johnson. Plans were originally in MAN.

Free Flight Gas Models, R.O.W., Class AA Open—6:38.8. Record established by Robert L. Holland, Sunland, Calif., on July 1. Model used was the 1948 third place Wakefield win-

ner converted for the Wasp .049 used and floats. Float arrangement was two main front floats and one tail float.

Free Flight Gas Models, R.O.W., Class A Open—12:05.8. Record established by Sal Taibi, Long Beach, Calif., on July 1, 1951 using an original design powered by an Arden .089. Taibi's model had a cabin type fuselage, 354 sq. ins. wing area, 150 sq. ins. stabilizer area, two main front floats and a tail float.

Free Flight Gas Models, R.O.W., Class AA Junior—1:05.0. Record established by Jerry Brown, Pasadena, Calif., on July 1, 1951 using an original design powered by a Wasp .049. Brown's model, known as the Freck had a 39" wing span, 30" fuselage length, one main front float and two tail floats.

Free Flight Gas Models, R.O.G.-Type, Class AA Open—28:27.0. Record established by Edward S. Gilkey, Central Point, Oregon on June 24, 1951. Ed's model was an AA Zeek powered by a K & B .049.

**INTER-CLUB COMPETITION.** In the early part of the season, the Rochester Model Aircraft Association (New York) got together with the Buffalo Flying Bisons in Buffalo to hold the first of a series of inter-club contests. For the contest, each club chose a five-man team for their representatives. Each of the team members were allowed to fly any or all of the official AMA events so long as he had at least one competitor from the opposing team. As there were actually only ten contestants, the remainder of both clubs acted as mechanics, timers and rosters so there was enough time and personnel to conduct the contest in rather a leisurely manner, permitting each contestant to his best. The sportsmanship displayed by both clubs was wonderful!

The atmosphere at these contests is that of an enjoyable Sunday afternoon's flying with the zest of a real competitive sport to top it off. The best thing of all about the inter-club contests is the team-work displayed in working together and helping each other—a spirit that is lacking in many organizations. Perhaps this type of competition will help make a club a stronger unit working for a common cause.

For those of you who would like to try this activity, John F. Wolff, President of the Rochester Model Aircraft Assn., has prepared an outline of the procedure and rules which, by all indications, appear workable.

1. The Buffalo club and the Rochester club had two joint meetings where it was decided to spend \$30.00 on two trophies with each club bearing half of the expense. Also the size of the teams was decided and it was decided that the AMA rule book would be the authority for the events. Furthermore, it was decided there would not be an event unless there was an entry from each team.

2. The trophies are to be one large and one small—both perpetual. At the end of each meet the club having won that particular meet will take possession of the small trophy until the following meet. At the end of the year the points won by both clubs will be totaled and the club having the highest score for the year will gain possession of the large trophy during the following year. The club winning the large trophy for the most times over a period of years will retain it permanently. The number of years will be determined by the room for engraving on the trophy, probably about five.

3. Before the flying starts, each team member registers the events he has come equipped



**HALF WILD GOOSE**

Winner of the '50 Nationals and scores of other contests. A proven 1/2A prizewinner that's easy to build, hard to break. Completely prefabricated kit with famous "Contest Tip" by National Champ Ted Hamelstein — \$2.25.



**HERCULES PAA LOAD**

"Best looking, best flying PAA Load yet," says Utah state champ Lowell Southern. Takes off and flies beautifully with full 3 oz. payload. Completely prefabricated kit with full size blueprints — \$2.75.

**COMBINATION KIT FOR HALF WILD GOOSE AND HERCULES PAA LOAD**

Includes completely prefabricated kit for Half Wild Goose fuselage and Hercules PAA Load fuselage with special wing and tail for use on either fuselage. Either both the 1/2A Free-flight and 1/2A PAA Load events merely by changing wing and tail to proper fuselage. Now you can build and fly two models for slightly more than the price of one. A real value at \$3.00.

**HOBBYMASTERS**

2600 E. Cammanwealth, Salt Lake City 6, Utah

Dealers and Distributors write.

If a local Dealer is not convenient, mail orders will be filled. Add 15c per kit.

# DIRECTORY

## For Hobby Dealers

**CALIFORNIA—BURBANK**  
Planes, Engines, Boats & RC Trains  
The most complete live model & handcraft  
supplies in San Fernando Valley  
OPEN Thurs. & Fri. evenings 6:00-8:00  
**GALLOWAY'S**  
House of Hobbies  
1825 W. Verdugo Ave. Char. 8-3674

**CALIFORNIA—LOS ANGELES**  
Nationally advertised model planes,  
boats, trains, kits and supplies.  
Weekdays and Mon.-Wed.-Fri. Evs.  
**PICO MODEL CO.**  
2540 W. Pico Blvd. DUNKirk 7-5894

**CALIFORNIA—MODESTO**  
Everything for Model Builders!  
Aircrafts — Railroads — Hobbies  
Open daily, Monday Morning & by appt.

**HAYS HOBBY HOUSE**  
908 "J" Street 6385-J & 7053-J

**CALIFORNIA—OAKLAND (11)**  
MECHANICAL HOBBIES  
Open 11 a.m. to 8 p.m.  
**MODEL CRAFT HOBBY SHOP**  
4336 Broadway Piedmont 5-2460

**CALIFORNIA—PASADENA**  
TRAINS—PLANES—BOATS  
Complete Line  
Kits—Tools—Supplies  
Pasadena's Hobby Center  
**ACE MODEL SHOP**  
1655 E. Colorado St. SY 3-6061

**CALIFORNIA—SAN PEDRO**  
Good Service! COMPLETE STOCK  
Planes — Boats — Cars — Artist's Materials  
Scale Models — RC Lineal Trains.  
(9 to 6 p.m.)  
**BRADFORD'S HOBBY &  
PAINT HEADQUARTERS**  
408 W. 6th St. TE 2-2804

**CANADA—TORONTO, ONT.**  
Model Aeroplanes, Motors, Trains & Boats.  
Hobby and Craft Supplies  
**BURDEN'S HOBBY LOBBY**  
114 Dundas Street West Plaza 3244

**FLORIDA—TAMPA**  
COMPLETE MODERN STOCK  
Planes, Engines, Ships, Trains,  
Race Cars, Tools & Supplies.  
EVERYTHING NUMBERED.  
**EDWARDS' HOBBIES**  
108 East Cass Street 26-2092

**ILLINOIS—CHICAGO**  
Model Airplanes—Tools—Engines  
Model Railroads—Ships  
Parts of All Kinds  
Visit Our New Big Store  
**ALL-NATION HOBBY SHOP**  
182 No. LaSalle St. DE 2-0850

**ILLINOIS—CHICAGO**  
Model Airplane Engines, Kits & Supplies.  
Model Railroads—Workshop Tools—  
Handicrafts  
Over 2,000 hobby items!  
**BURGESS HANDICRAFT STORES**  
182 North Wabash Avenue  
Randolph 8-3647

**MASSACHUSETTS—CAMBRIDGE (38)**  
Model planes, motors, railroads, ships  
and accessories.  
9 A.M. to 6 P.M. daily & Thurs., Sat. evenings.

**CROSBY'S HOBBY CENTRE**  
1704A Massachusetts Ave. KI 7-4389

**MISSOURI—KANSAS CITY**  
Model Airplane, Boat, Race Car,  
Inland & Hobby Supplies  
Open 10 to 11 Mon. Thurs. & Sat. 9:00 to 10  
Sun. 10 to 11

**NORTHEAST HOBBY CENTER**  
4825 Independence Ave. BE 7849

**NEBRASKA—NORTH PLATTI**  
COMPLETE STOCK OF MODEL AIRPLANES,  
RAILROADS, BOATS, RACERS &  
HANDICRAFTS  
Open 9:00 a.m. to 7:00 p.m. daily  
10:00 a.m. to 9:00 p.m. Saturdays  
**THE HOBBY SHOP**  
415 North Jefferson St. 2688

**NEW JERSEY—HADDONFIELD**  
South Jersey's Complete Model Shop.  
Largest Stock  
Planes Engines Supplies  
Open noon till nine daily  
**HIGHWAY HOBBY HOUSE**  
20 Tanner St. Haddonfield 9-6860

**NEW YORK—BUFFALO**  
MODEL AIRPLANES—ENGINES—BOATS  
HANDICRAFT—TRAINS—SUPPLIES  
Open Daily Except Weds.  
Evenings on Thurs. & Sat.  
**HOWARD E. RUTH**  
1466 Genesee St. Taylor 4126

**NEW YORK—NEW YORK**  
In New York it's POLK'S  
for all hobbies.  
Come in and see us!  
**POLK'S MODEL CRAFT HOBBIES**  
314 Fifth Ave. BR. 9-9034

**OHIO—DAYTON**  
Convince yourself  
Since 1928 folks traveled many miles  
to shop our mammoth stock.  
Open Sunday  
**GOOD'S HOBBY SHOP**  
1729 N. Main St. Taylor 5378

**OHIO—LAKIWOOD (CLEVELAND)**  
Open Week Days 10:00 a.m. to 9:00 p.m.  
Suns. & National Holidays 12:00 Noon  
to 3:00 p.m.  
Closed Thanksgiving, Christmas, New Year's

**HOBBY ENTERPRISES, INC.**  
16302 Detroit Ave. BOulevard 2-1675

**OREGON—PORTLAND**  
PLANES—BOATS—RAILROADS  
RACERS—HANDICRAFT  
**VIC'S HOBBY SUPPLY**  
10 a.m. to 6 p.m. — Closed Sundays  
1824 N.E. 40th Ave. GA. 3108

**PENNSYLVANIA—GETTYSBURG**  
Model Planes—Motors  
Railroads, Ships & Accessories  
Open daily 9 p.m. to 10 p.m.  
Sun. 1 p.m. to 10 p.m.  
We Trade  
**GILBERT'S HOBBY SHOP**  
2 S. Franklin St. Phone 706-X

**PINN.—PITTSBURGH 16, DORMONT**  
If it's worth selling, we have it!  
TRAINS—PLANES—BOATS—SUPPLIES  
MISC. CHAPTER  
Open Mon., Wed., Fri. evs. 1:00-8  
**A. B. CHARLES & SON**  
3229 1/2 W. Liberty Ave. FO 1-3068

**WASHINGTON—SEATTLE**  
GOOD SERVICE — HELPFUL ADVICE  
Complete Stock  
PLANES—BOATS—CARS—HO TRAINS  
10 to 11 PM W. Y. to 9 PM  
**BUZZ & DOUG'S HOBBY SHOP**  
701 E. Pike at Boylston EA 8630

to fly. This way the officials can tell in a few moments what events are to be held and the judges and timers are assigned.

4. Points are awarded as follows: 1st place in any event—three points, 2nd—two and 3rd—one.

5. As many of these meets will be held a year as reasonably possible.

An interesting sidelight to the contest is the fact that the clubs (both of them) are seriously practicing events that the opposing club are weak in, showing the contests are really being taken seriously.

The *New York Aero Nuts* which boasts of charter members such as Pete Andrews, Frank Ehling, Sidney November, Paul Piccan, Bernard Shoenfeld, Stan Stanwick, and Frank and John Zaic, just to name a few, is having a membership drive. To hear the names we've just mentioned, you'd think the Aero Nuts were a bunch of hot shots. Well, they are but the requirements for admission to the club have now been altered to allow comparatively inexperienced modelers who want to learn to fly to join. Why don't you contact Stan Barbakoff, President of the *Aero Nuts*, 39 Scholes St., Brooklyn 6, N. Y.?

**CONTESTS**

**SEPTEMBER**

2—Medina, O. Class AA Second Annual Medina Model Meet for all outdoor events excepting TR and Jct. R. W. Housley, Contest Director, 2190 23rd St., Akron 14, O.

2—Salem, Ore. Class AA Salem Model Airplane Club 13th Annual Meet for FFG and OR. Elmer J. Roth, C.D., 2080 Market St., Salem, Ore.

2—Phillipsburg, N. J. Easton-Phillipsburg Plymouth Meet for FFG, CL, CLS, and CLFS. William Lehman, C.D., 47 East State St., Doylestown, Pa.

2—Taft, Calif. Taft Record Trials for FFG. Francis Stewart, C.D., 900-21, Bakersfield, Calif.

2 & 3—Pawtucket, R. I. Class AAA All New England Model Meet for CL, CLS, CLFS, FFG, OR, and TR. Arthur C. Bergeron, C.D., 55 Ricard St., Seekonk, Mass.

2 & 3—Waterloo, Ia. Class AA Waterloo Prop

Twisters' Model Meet for CL, CLS, CLFS, FFG, HLG, TLG, and RC. Kenneth Satterlee, C.D., 1146 West 12th St., Waterloo, Ia. Pending.

3—Far Hills, N. J. Class AA Bedminster-Far Hills Lions Club 4th Annual Control Line Meet for CL, CLS, and Beauty events. James T. Christian, C.D., Dunwalke Farm, Far Hills, N. J.

3—Morganton, N. C. Class AAA North Carolina Recreation Society Model Plane Contest for CL, CLS, and CLFS. Entry is restricted to members of the North Carolina Recreation Society. John T. Vogler, C.D., 131 W. 4th St., Charlotte, N. C.

9—New Britain, Conn. Class AAA Connecticut State Championships for CLS, CLFS, and CL. Richard G. Matava, 388 Prospect St., Hartford, Conn., and Michael Adajian, 30 Brooklawn St., New Britain, Conn., C.D.'s.

9—Akron, O. Class AA Inter-City Wakefield Type Team Competition. Henry Thomas, C.D., 515 Mohawk Ave., Akron, O.

9—Chicago, Ill. Class AA Chicago U-Liners' 5th Annual Open Contest for CL and CLS. R. F. Antrim, Jr., C.D., 10752 South Washington, Chicago 43, Ill.

9—Doylestown, Pa. Class AAA Doylestown Model Airplane Contest for CL, FFG, CLS, and CLFS. William Lehman, C.D., 47 East State St., Doylestown, Pa.

9—Bakersfield, Calif. Bakersfield Record Trials for all classes of FFG. Francis Stewart, C.D., 900-21, Bakersfield, Calif.

16—Visalia, Calif. Visalia Model Airplane Assn. Record Trials for all classes of FFG. Emory O. Hull, Jr., C.D., P. O. Box 284, Ivanhoe, Calif.

16—New York, N. Y. Class AAA Tenth Annual Prop Spinners Northeastern Championships for OR, FFG, and RC. William Fletcher, C.D., 8706 Grand Ave., Elmhurst, L. I., N. Y.

23—Harrisburg, Pa. 7th Annual Pa. State Exchange Club Meet. Entry is restricted to residents of Penna. Write to Howard J. Aldworth, 102 West Market St., West Chester, Pa., for information. Pending.

**OCTOBER**

6 & 7—Woonsocket, R. I. Class AA Flying

Fools' Fair for OR, FFG, CL, CLS, and TR. Thaddeus W. Wenclawik, C.D., 58 Providence St., Woonsocket, R. I.

13 & 14—Los Angeles, Calif. Class AAA All Western Open Model Aircraft Meet for indoor, outdoor free flight, and control line events. Tom U. Engleman, C.D., 2459 Heliotrope Dr., Santa Ana, Calif. Pending.

14—Bakersfield, Calif. Bakersfield Record Trials for FFG. Francis Stewart, C.D., 900-21, Bakersfield, Calif.

21—Visalia, Calif. Visalia Model Airplane Assn. Record Trials for FFG. Emory O. Hull, Jr., C.D., P. O. Box 284, Ivanhoe, Calif.

**NOVEMBER**

11—Bakersfield, Calif. Bakersfield Record Trials for FFG. Francis Stewart, C.D., 900-21, Bakersfield, Calif.

18—Visalia, Calif. Visalia Model Airplane Assn. Record Trials for FFG. Emory O. Hull, Jr., C.D., P. O. Box 284, Ivanhoe, Calif.

**DECEMBER**

8—Bakersfield, Calif. Bakersfield Record Trials for FFG. Francis Stewart, C.D., 900-21, Bakersfield, Calif.

16—Visalia, Calif. Visalia Model Airplane Assn. Record Trials for FFG. Emory O. Hull, Jr., C.D., P. O. Box 284, Ivanhoe, Calif.

28, 29, and 30—Orlando, Fla. 2nd Tangerine Internationals. Pending.

Key to listing of events: FFG—Free Flight Gas; CL—Control Line Speed; OR—Outdoor Rubber; TLG—Towline Glider; IR—Indoor Rubber; OHLG—Outdoor Hand-Launched Glider; IHIG—Indoor Hand-Launched Glider; CLS—Control Line Precision (Stunt); CLFS—Control Line Flying Scale; RC—Radio Control; TR—Team Racing.

Contests designated "Pending" mean the application is before the proper authorities as we go to press; "Record Trials" mean no prizes, but a chance at cracking the records; "Class A" is a meet with restricted entry; "Class AA" is a meet with unrestricted entry; "Class AAA" is a state-wide or regional meet; "Class AAAA" is a national or international meet.

END

## MR. DEALER—

Anticipate Your Christmas Needs—Order NOW for Convenient Delivery.



WRITE FOR YOUR CATALOG. REPLIES WILL BE MADE TO INQUIRIES ON OFFICIAL STATIONERY ONLY.

# MOD Kraff Co

840 Union St., New Orleans 12, La.



Class AB (19-24)  
Area 110 sq.

\$4.50

By Mail \$4.75

The SUPER FLASH is designed for tough flying competition. Construction is strong, its flying ability is readily made a name for itself. To get the utmost of its speedy climbing ability, adjustable wing slatons have been added to the wing.



Class A/2  
Seaplane

\$2.25

By Mail \$2.50

The PHOENIX SKIPPER quickly bogs off its water, climbs high and carries loads in a flat glide. The floats can be put on or off in a jiffy. Without floats the model makes a fast control land glide with an exceptional flat landing glide. Make no mistake, it is the best model for the money.

JUNIOR AERONAUTICAL SUPPLY CO.  
100 EAST 15th ST., NEW YORK 3, N. Y.

## BEAUTIFULLY DETAILED SOLID MODELS



P-47 THUNDERBOLT . . . \$2.95

British Spitfire	\$2.75	P-51 Mustang	\$2.75
FW-190 Focke Wulf	2.75	F6F Hellcat	2.75
P-40 Warhawk	2.75	F8F Bearcat	2.75
F4U Corsair	2.75	P-38 Lightning	3.50

ME-109 Messerschmitt \$2.75

Ask your dealer for "Dyna-Model". If he cannot supply you write us direct, enclosing check or money order plus 25¢ for packing and postage—no C. O. D.'s.

Watch our ads for Dyna-Model's new JETS!

**DYNA-MODEL PRODUCTS COMPANY**  
76 SOUTH STREET, OYSTER BAY, NEW YORK

## Planes In The News

(Continued from page 15)

X-1 on its first ride through sonic speed. With the turbojet out of the way Douglas was able to double (approximately) the amount of rocket propellants. And some further cleanup was possible. The inlet scoops were faired over and so was the jet tailpipe which had discharged through the aft fuselage belly.

Bill Bridgeman, Douglas test pilot who flew the Skyrocket, said that he passed smoothly through sonic speed, and continued into the supersonic with the plane maneuvering nicely. Powered flight continued for about three minutes, during which Bridgeman said he was too busy to look around. After about a 20-min flight, he touched down on the runway at Edwards, dead-stick and at about 170 mph.

The Skyrocket is a product of Douglas' El Segundo division. On another side of Los Angeles, the Santa Monica division is getting the Douglas X-3 ready for its first flight. Maiden voyage should be just days away by the time you read this. Reported design top speed of the X-3 is 2,250 mph, at nearly 300,000 ft. altitude. The plane is made of stainless steel, and the wing section is a very thin diamond shape, technically called a double-wedge section.

Far from the "city of the angels," Bell Aircraft Corp. should be about ready to ship out its X-1A for flight tests. This little ship is primarily the first-through-sonic-speed X-1 with some changes. First and foremost difference is the substitution of a turbo-pump propellant feed system for the pressurized system of the X-1. This means increased duration and therefore a higher speed for the same basic airframe and weight. Other changes include a lengthened fuselage, a completely new protruding canopy, a reworked fairing from canopy to tail, and new hinging arrangements for elevators and ailerons.

**Military Transport**—The Pentagon boys have put together the pieces of the jigsaw puzzle labeled "Military Transport" and have come up with the whole picture. Here's the way things are to stack up for the next few years at least: for assault transport, the Chase C-123 (prototype crashed recently at Eglin AFB, Florida, when one engine cut just as the plane got into the air); for medium troop and cargo transport, the Fairchild C-119, being built jointly by Fairchild and Kaiser at Willow Run; for long-range freight and personnel, the Douglas DC-6A and the Lockheed Super Constellation L-1049; for a strategic heavy weight-lifter, the Douglas C-124, perhaps in the turboprop version; aerial tanker duties will be handled by the Boeing KC-97; all-purpose transport (which reminds me of the old story about the idol of the unknown god) will be handled by the Lockheed L-206.

Incidentally, the reference to the statue of the unknown god is in an ancient story about a people who worshipped a whole variety of gods—one for sky, one for earth, one for water, one for light—through an imposing list of deities. They prayed diligently to the proper god for the proper things. And they erected statues to represent the deities. But somebody in the area had the thought that maybe they had left out one of the gods, and that said god might be offended. So to placate him, and to make sure nobody had been overlooked, the populace put up a statue marked, "To the Unknown God."

The moral here is that the AF has done its planning for just about every conceivable type of transport requirement. But just in case they happened to have forgotten one, they have rung in this "all-purpose" deal.

The only new plane in the list is Lockheed's L-206. This ship is a four-engined turboprop freighter. Currently nothing more than a design study, the L-206 was one of two Lockheed responses to an Air Force invitation to bid on the job. And it will take about two years to get a prototype into the air, says the AF.

The plane has a high-wing layout, somewhat resembling the Chase C-123, with large aft cargo doors. There are four Allison T-38 turboprop engines developing 2,750 hp. each. Basic specs called for a range figure of 2,600

mi. couples with a payload of 25,000 lb.

## ENGLAND

**Handley Page 88**—This is a strange-looking beast. It's classed as an experimental craft with the job of testing a new wing. Judging by the photos, this new lifting surface has three sections of different sweep angles on the leading edge. Leading edge slots (or flaps or slats) are fitted to the two outboard sections of the panel. The aileron has a very large chord (percentage wise) at the tip section, but stays at a constant dimension moving inboard on the surface. Near the inboard end of the aileron is mounted what appears to be a high-aspect-ratio wing swept forward at about 45 degrees. And near the fuselage are two booms projecting aft.

I have no idea what those booms do, but there are two possibilities. One, they are supports for some tricky kind of trailing-edge flaps (and Handley Page has been advocating such flaps); two, they are imitation jet engines. Now this last sounds screwy without some kind of explanation. And here it is.

Handley Page has one of three contracts for four jet bomber prototypes for the RAF. And generally, the British philosophy is to get the engines in close to the fuselage. So let's say that the new Handley Page jet bomber sports a wing planform like the one of the HP 88. For flight tests, a scaled-down wing is easily made; not so a scaled-down jet engine. And for tests of wings with internal storage of heavy items, oftentimes a dummy load is used. Suppose that the jet engine's weight and weight distribution are represented by heavy steel or dural chunks. Then the result might just be two booms sticking aft.

Incidentally, the blister on the fuselage sides just ahead of the tail looks like some kind of a dive brake. This impression is furthered by the location of a hydraulic fluid access panel on the fuselage side just above the blister.

The airplane itself is a joint constructional and design effort by Handley Page and Blackburn and General Aircraft, Ltd. The fuselage was taken from a Vickers Supermarine Attacker. And this goulash is powered by a Rolls-Royce Nene.

**Vickers Supermarine 535**—Since we ran the three-view of the latest RAF fighter (MAN, Aug. 1951), the British have obsoleteated that drawing by adding a dorsal fin to the ship. It's a tiny thing, curving into the fuselage upper deck from the leading edge of the fin.

**Avro York**—The first tramp steamers of the air are to go into service in England sometime in the near future. Lancashire Aircraft Corp. bought 23 Avro Yorks, outmoded passenger transport of British Overseas Airways Corp., and is in the process of refitting them. The planes will carry passengers or freight or both anytime, anywhere.

**Fairey 17**—The name of the new anti-submarine craft, the Fairey 17, is officially the Gannet. If memory serves, the first name the British hung on the Grumman Helicat F6F was the Gannet; and there was a Gloster Gannet way back somewhere. Besides a gannet is a sea bird which folds its wings to dive on its prey, a very neat stunt, but not for planes. And Fairey Gannet is not alliterative.

Time out for some speculation. Saunders Roe Ltd., British builders of flying boats, have been somewhat less than subtle in their recent ads. The manufacturers of the famous S.R./A1 jet-propelled flying-boat fighter just ran a page which said "... there are people who think the flying boat can never equal the landplane in performance ... how wrong they are!"

Then too, the firm has been running front cover advertisements on Flight and Aeroplane, showing paintings of a flight of flying-boat fighters. The planes are very clean, with definite advances shown over the S.R./A1. Wings are swept, side inlets for engine air are used, and there is a radar bulb in the nose. Would anyone care to bet on the possibilities of a headline shortly which says that Saro is about to fly a new fighter boat?

## FRANCE

**Marcel Dassault 452**—The Mystere, swept-wing version of the Ouragan (which we (Continued on page 56)



The most powerful  
fuels compounded  
for your engine!

more **PURRRR** per pint!

- Prolonged engine life.
- Easier starting.
- Positive lubrication.
- More RPM

O & R Super AA fuel is specially compounded for peak performance in ultra small engines under .19 cu. in. Super AA fuel not only prevents engine varnish, tar and carbon from forming, but actually removes deposits left by makeshift fuels. Super AA fuel contains the correct nitrated content to assure maximum RPM and power.

All O & R fuels contain gum free Castor oil in addition to a once "top secret" lubricant developed during world war II. This lubricant is a synthetic organic chemical and contains no wax. It will not form sludges and gums usually caused by ordinary lubricants.

AVAILABLE AT ALL GOOD MODEL SUPPLY HOUSES EVERYWHERE



**Ohlsson & Rice, Inc.**

Emery at Grand Vista,

Los Angeles 23, California

# Berkeley

## THE OUTSTANDING NAME IN- COMPLETELY PRE-FABRICATED SCALE CONTROLINERS!

### Betty Skelton's "PITT'S SPECIAL"

.19 to .33 Engines — 25½" Span

The kit is produced with the permission of Miss Betty Skelton, National Aerobatic Champion, to use her personal insignia furnished in the kit on decals.



\$4.95

\$5.95

### "CESSNA 195"

.19 to .49 Engines — 36" Span

Completely Pre-fabricated, featuring the "Step-Keel" Fuselage construction.



\$5.95

### NORTH AMERICAN "T-28"

.19 to .36 Engines 30"

Completely Pre-fabricated, featuring the "Step-Keel" Fuselage construction.



\$5.95

### "MINNOW"

.19 to .36 Engines — 28" Span

Completely Pre-fabricated, featuring the "Step-Keel" Fuselage construction.



\$5.95

### P-51 "MUSTANG"

37" SPAN - .19 TO .35 ENGINES

This Deluxe kit incorporates a landing gear which may be retracted or extended at will, including the tail wheel. Automatic flaps, engine throttle control as well as elevator and "Autotrol" rudder operation make this laminar-flow airfoiled fighter an outstanding controliner. A specially machined four-notched aluminum spinner is included.



\$4.95

### F-8-F "BEARCAT"

35½" SPAN - .29 TO .65 ENGINES

"Autotrol" automatic rudder control with ground-operated "U-Control" elevators, prevent slackening of lines in critical maneuvers.



### P-47 "THUNDERBOLT"

40¼" SPAN - .29 TO .65 ENGINES

Engine Throttle control and fully automatic wing flaps make full scale-type flights possible with this famous battleship of the air. A special feature of this outstanding performer is the shear-pin motor mount.

\$4.95

\*Manufactured under license, Jim Walker's "U-Control" Patent No. 2292416, and Bill Ellinger's "Autotrol" Patent No. 2523902. "Controliner" is registered trade mark of Berkeley Models, Inc., West Hempstead, N. Y.

1951 CATALOG AVAILABLE

At Your Dealers,  
or write direct.  
25c

SOLD THRU  
**BERKELEY**  
DEALERS & DISTRIBUTORS

IF NO LOCAL DEALER IS CONVENIENT, MAIL ORDERS WILL BE FILLED BY BERKELEY MODEL SUPPLIES, DEPT. MA., WEST HEMPSTEAD, N. Y. PLEASE INCLUDE 25c PACKING AND POST.

showed you in April, 1951) made its first public flights at the Paris Salon l'Aeronautique in mid-June. Those of us who habitually see newsreels on TV got a fine view of those flights. The *Mystere* looks like it has a sweep angle of about 35 degrees or so. Takeoff, and climb after takeoff, appeared good but not exceptional. The high-speed passes, difficult to judge, would rate the *Mystere* up with current fighters. And the French say that the plane has already topped 634 mph., the first French plane to do so. And roll—the *Mystere* corkscrewed its way down the field at a tremendous rate.

### RUSSIA

**Tu-10**—First photo of the Tupolev 10, twin-jet light bomber of the Red Air Force, shows that the plane is now using small wingtip tanks. These planes are currently reported in squadron service in three versions: a trainer, with the nose solid and no radar or guns; an all-weather model; and a ground-support model. We had a three-view of the Tu-10 last month on these pages.

**Bits and Pieces**—The planes featured this month in three-view are the Pulquit II, Argentine's jet fighter, and the Morane-Saulnier 731. We chose the first because the plane has an interesting history; the second, because it was one of the planes exhibited at the big French annual aeronautics display. There is an attempt, in case you hadn't noticed, to make the three-views presented each month the kind of planes that you'd like to model. We try to give you one jet and one prop-driven craft, which between them cover an enormous range of possibilities. The way things are now, it gets harder and harder to find a propeller-driven craft to draw each month. And so here's an appeal—if you have any particular planes you'd like given the treatment, just drop me a line in care of MAN and we'll see what can be done.

## INDEX TO ADVERTISERS — OCTOBER, 1951

Ace Products	48
Aero-Tech	48
All American Model Motor Exchange	52
American Telasco Ltd.	37
America's Hobby Center, Inc.	5, 6, 7
Mel Anderson Mfg. Co.	2, 3, 31, 45
Arnold & Fox Engineering Co.	47
Atwood Manufacturing Co.	4
Berkeley Models, Inc.	2, 3, 56
Carter Craft Models	46
Cleveland Model & Supply Co.	41
Comer Model Hobbycraft, Inc.	49
Consolidated Model Engineering Co.	40
Dealer Directory	53
Duncan Craftsmen, The	48
Dura-Matic Products Co.	4th Cover
Dyna-Model Products Co.	54
Francisco Laboratories	40
Gotham Hobby Corp.	46
Guillow, Paul K.	35
Herkimer Tool & Model Works, Inc.	8
Hobbies-Toys of Hollywood	51
Hobbymasters	52
Junior Aeronautical Supply Co.	54
K & B Manufacturing Co.	3rd Cover
Kramer Brothers	50
Vernon C. MacNabb Co.	46
Maxwell Model Supply Co.	50
Mod-Ad Agency, The	6
Mod Kraft Co.	54
Model & Hobby Industry	48
Monogram Models, Inc.	39
National Model Distributors	40, 50
Ohlsson & Rice, Inc.	55
Pactra Chemical Co.	2, 3
PAL Engineering Ltd.	52
Perfect Quality Model Accessories	50
Polk's Model Craft Hobbies	44
Radercraft Publications, Inc.	36
Scranton Hobby Center	52
Southland Models	48
Stewart-Lundahl Co.	2, 3, 46
Sullivan Products	2, 3, 4
Super-Cyclone, Inc.	42
Testor Chemical Co.	2nd Cover, 28, 29
Top Flite Models, Inc.	43
X-Acto Crescent Products, Co., Inc.	38

20th  
National A.M.A.  
Model Airplane  
Meet

**TORPEDO WINNERS**

Class A & Jr.  
Don Tune - 1st  
Class AA & Open  
Mich. Everett - 1st  
Class B & Jr.  
Gene Jackson - 1st  
Class B & Sr.  
James Carpenter - 1st  
Class FF Open  
Bob Ottoman - 1st  
PAA-Load Class AA Jr. Sr.  
Gene Jackson - 1st  
PAA-Load Class AB Open  
Herbert Kothe - 1st

**TORPEDO WINNERS**

Class A & Open  
Ray Mathews - 2nd  
Class B & Jr.  
Curtis Franke - 2nd  
Class C & Jr.  
Curtis Franke - 2nd  
Class C & Sr.  
John Belote - 2nd  
PAA-Load Class AB Open  
Sal Taibi - 2nd  
Class B & Sr.  
Fred Salmon - 3rd  
Class B & Open  
James Summerset - 3rd  
Class C & Sr.  
John Ogren - 3rd  
PAA-Load Class AA Jr. Sr.  
Jan Lowe - 3rd  
PAA-Load Class AB Jr. Sr.  
James Carpenter - 3rd

*A  
Consistent  
Winner*

**K&B  
TORPEDO**

the greatest  
name in  
model aircraft  
engines

**TORPEDO  
ENGINES**



**K&B MANUFACTURING CO.**  
224 E. PALMER AVE.  
COMPTON, CALIF.

*For Fun or Trophies*

**BIG  
VALUE!**



*Baby "MAC"*  
*.049*



a *Real* **DURO-MATIC** *McCoy*

Holder of MORE Official AMA  
World Speed Records, than any other engine  
FLY THE ENGINE *Champions Fly!*

for only **\$595**

You will never know,  
how wonderful engine performance can be,  
until you fly a *Real* **McCoy**



**DURO-MATIC PRODUCTS COMPANY**

HOLLYWOOD 38, CALIFORNIA