

THE WORLD'S ONLY RC SCALE MODEL MAGAZINE

SCALE FROM SCRATCH

PART 9: PULLING IT ALL TOGETHER

www.flyingscalemodels.com

Flying Scale Models

RYAN PT-22 'RECRUIT'

FULL SIZE FREE PLAN
WORTH £24.95

PART 2: CONTINUING THE CONSTRUCTION OF PETER RAKE'S ELECTRIC POWERED, 52" SPAN SPORT SCALE MODEL.



MASTER MODELS

RAZORBACK

SUPERB COMPOSITE ARF P-47D THUNDERBOLT IN 1:4.5 SCALE
● THUNDERBOLT WARPAINT ● SUPER DETAILED SCALE THREE-VIEWS

MILES MAGISTER

BUILD THIS .40 POWERED SIMPLE SCALE MODEL OF THE R.A.F.'S WW2 BASIC TRAINER IN 1/7TH SCALE

PLUS: SCALE THREE-VIEWS - SUBJECTS FOR SCALE WITH DETAIL & FLYING COLOURS

SHOWTIME

BMFA SCALE NATIONALS 2015



GET YOUR HANDS ON **ULTRA POWER**



CHARGE ...your passion

OptiFUEL™ is one of the fastest growing brands in Europe with competition winning Nitro fuel products for the RC Model sector, now OptiFUEL™ is delighted to add a new brand OptiPOWER™ which will be the flagship brand for the new range of RC Chargers and LIPO cells.



> **ORDER NOW** FROM YOUR LOCAL RETAILER
FIND YOUR SPEC @ www.optipower.co.uk

OptiPOWER™
...your passion

THE ISSUE AHEAD...

FORMATION...

FLYING SCALE MODELS - THE WORLD'S ONLY MAGAZINE FOR SCALE MODEL FLYERS



6



22



36



ON THE COVER

Tim Simmonds built this superb model of the Republic P-47D Thunderbolt from the Composite ARF kit. At 1:4.5 scale, it spans 112" (2845mm) and tips the scales at 52 lbs. (23.6 kg) with five-cylinder Moki 250cc radial engine.. Alex Whitaker reviews it in this issue.

NOVEMBER 2015 NO.192

4 CONTACT

Just for starters

6 MILES MAGISTER

Built this .40 powered simple scale model of the R.A.F.'s WW2 basic trainer in 1/7th scale

12 SUBJECTS FOR SCALE: MILES MAGISTER

Type History and Close-Up detail photo study

18 MILES MAGISTER COLOURS

Colour schme choices

20 MILES MAGISTER SCALE DRAWING

1:50 fine-line three views

22 RAZORBACK SNAFU

Superb Composite ARF's 1:4.5 scale Republic P-47D reviewed

30 RAZORBACK COLOURS

Warpaint for the P-47D 'Razerback'

34 RAZORBACK SCALE DRAWING

Super-detailed fine-line three views

FULL SIZE FREE PLAN FEATURE

36 RYAN PT-22: PART 2

Full size free plan construction feature for an electric powered, 52" (1320mm) span sport scale model, designed by Peter Rake

40 RYAN COLOURS

Colour schemes for the Ryan 'Recruit'

42 RYAN IN DETAIL

Detail close-up photo study

48 DESIGN DIY PART 9

Further progress in the completion of Ken Sheppard's Dornier Do.335 'Pfiel'

52 TECHNO SCALE

Mike Evatt taps into the web for more TechnoScale Topics...

54 BMFA SCALE NATIONALS 2015

Alex Whattaker mingles with The Lords Of Scale at, possibly, the last Barkston Scale Nats

62 THE QUIET ZONE

Our Columnist pays tribute to the sterling work undertaken by Pat Lynch, marathon test builder for the ongoing Peter Rake design office!

Editor: Tony Dowdeswell
Publisher: Alan Harman
Design: Peter Hutchinson
Website: ADH Webteam
Advertising Manager: Sean Leslie
Admin Manager: Hannah McLaurie
Office Manager: Paula Gray

FLYING SCALE MODELS is published monthly by ADH Publishing, Doolittle Mill, Doolittle Lane, Totternhoe, Beds, LU6 1QX. Reproduction in part or whole of any text, photograph or illustration without written permission from the publisher is strictly prohibited. While due care is taken to ensure the contents of Flying Scale Models is accurate, the publishers and printers cannot accept liability for errors and omissions. Advertisements are accepted for publication in FLYING SCALE MODELS only upon ADH Publishing's standard terms of acceptance of advertising, copies of which are available from the advertising sales department of FLYING SCALE MODELS.

EDITORIAL ADVERTISEMENT

& CIRCULATION: Doolittle Mill, Doolittle Lane, Totternhoe, Beds, LU6 1QX.
Tel. 01525 222573 Fax. 01525 222574.
Email: enquiries@adhpublishing.com

CIRCULATION TRADE ENQUIRIES:

Seymour Distribution, 2 East Poultry Avenue, London, EC1A 9PT
020 7429 4000.

NEWSTRADE: Select Publisher Services, 3 East Avenue, Bournemouth, BH3 7BW.
01202 586848
Email: tim@selectps.com

SUBSCRIPTIONS: Doolittle Mill, Doolittle Lane, Totternhoe, Beds, LU6 1QX.
Tel. 01525 222573. Fax. 01525 222574.

PRINTING: Symbian Print Intelligence, Calverley House, 45 Dane Street, Bishop's Stortford, Herts, CM23 3BT.
Tel: 0870 870 1670; Fax: 0870 870 1675

**(c) Copyright Flying Scale Models
2015 ADH Publishing.**

The paper used on this title is from sustainable forestry

CONTACT

As Alex Whittaker indicates in his report on the BMFA Nationals this month, it seems likely that the long running annual late Summer Holiday association with RAF Barkston Heath many have run its course.

As far as the Scale competition element of this long holiday weekend is concerned, the entry on each of the competition classes has been progressively dwindling to a disappointing level - the combined total, across all three R/C classes at this year's event was only 27.

Of course it's true that the 'Nats' is not just about Scale R/C, there's also R/C Aerobatics, a full complement of competition Control Line events and the R/C Demo Line, where Scale dominates, plus the unique goings-on in the sprawling camp site - all of which makes our Nationals what it is.

'Barkston' has been the annual Nats venue for longer than I can immediately remember - only RAF Hullavington in Wiltshire during the Mid-1960s through to the early '70s comes close. I can't remember now what happened between the Hullavington and Barkston years (if any), but I can remember periods of 'orphan' status when our premier model flying competition event drifted around the country including one year at RAF God-knows-Where (can't remember the now!) somewhere in the Hadrian's Wall area, plus enjoyable years at RNAS Yeovilton and RAF Little Rissington - typical examples of airfield facilities long gone as our armed services have contracted.

Options these days, could well be even fewer - it needs a wide open airfield space, wholly inactive for a long Saturday-to-Monday weekend, if our Nationals, in its present conception can be held together without a split to multiple-site arrangement across the different aeromodelling disciplines.

Securing a new site that will accommodate it may well take some determined negotiation and presumably it is already a priority for our BMFA.

NEXT MONTH IN FSM ...

Is it a bird, is it a 'plane? No, it's neither! Ken Sheppard has long been drawn to aeronautical oddities and to making these work at modelling sizes. And they don't come much more odd than the WW2 Blohm-und-Voss Bv 141 reconnaissance and ground attack aircraft.

Ken successfully modelled the type at 108" (2743mm) wingspan and 40-50cc peter engine power, and will present a full plans construction feature in our December issue, on sale November 12th.



RadshapeRC.com™ 0121 3512728

We are a real shop with real stock, no online 'shadow stock' here.... so fly by anytime



8000 Soft
SHOWROOM
See & pick up
the products



LARGE STOCKS



SPARES



SERVICING

• Easily accessible
from A38, M6 Jct6
near Birmingham

• Large Free
Car Park

• On-site
refreshments

• 'Price Match' any physical
shop with actual stock



Follow
us on...



RadshapeRC



@RadshapeRC



RadshapeRC



RadshapeRC, Unit J10 Minworth Trade Park, Fulford Drive, Minworth, West Midlands, B76 1DJ

The British Model Flying Association

Protecting and promoting
UK model flying for over
90 years.

£25 Million liability cover
for all lawful recognised
model flying activity as standard.

Join at www.bmfa.org/join

2015 Reduced Fees - applicable from 1st Sept
Senior £16, Junior £9,
Family Partner £11, Family Junior £7

Join via the website, over the phone or send payment with this advert
*Membership year runs to 31st Dec 2015

BMFA



Mr/Mrs/Miss..... D.O.B.....
Address.....
Postcode..... Tel:.....
E-mail..... Make Cheques payable to BMFA



BMFA, Chacksfield House
31 St Andrews Road, Leicester,
LE2 8RE
T: 0116 2440028
E: admin@bmfa.org

www.bmfa.org

MILES MAGISTER

A .40 powered simple scale model of the R.A.F.'s WW2 basic trainer is 1/7th scale designed and built by Ken Sheppard and Mike Reynolds

It was quite a long time ago now ago when pencil first touched paper on this design. Being well into .40 sized models then, the benefit of living quite close to Old Warden where an example of the full-size Magister resides, gave the golden opportunity to have a go at making an accurate replica - at a convenient size. The model was started in a rush of enthusiasm, foam wings were cut and the tail units made up, all in a matter of a few days. With the wing to hand, I was able to start on the fuselage and soon had it married to the

wing - then, out of the blue, an unexpected change in the day job meant that it had to be put on the back burner. The parts were carefully wrapped up and consigned to the loft - since then my interests have taken me to other projects, other prototypes and the old 'Maggie' was forgotten - for quite a while.

However, the drive to get the model eventually returned to get mine finished - having moved on to bigger and more complicated models, the prospect of going back to a small sports-scale model suddenly had a lot of appeal. It didn't

work out quite like that - the scale-detailing bug had bitten hard by then, but it prompted me to venture into the loft and blow the dust off my earlier efforts. My trusty O.S. 48FS Surpass was available and was a perfect fit in the cowl, (made in the manner featured in a very early issue FSM) and was soon bolted onto the firewall bulkhead. I had originally planned to use thin plywood for the top decking as per the full size and had, the first time around applied the cockpit decking using 1/32" ply sheet, but having become an enthusiast for blue foam, the

Even at this moderate size, a bit of careful detailing and accurate colouring really brings out the character of the 'Maggie'.



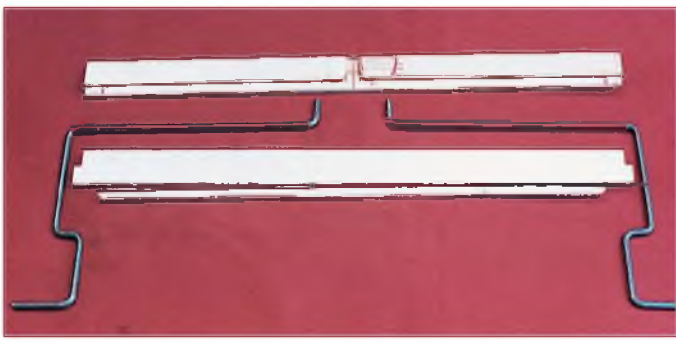

Taken down from the loft and dusted off, the fuselage and wing were still in good shape - it was even possible to find some old build-shots as a reminder of how the undercarriage 'sandwich' went together.

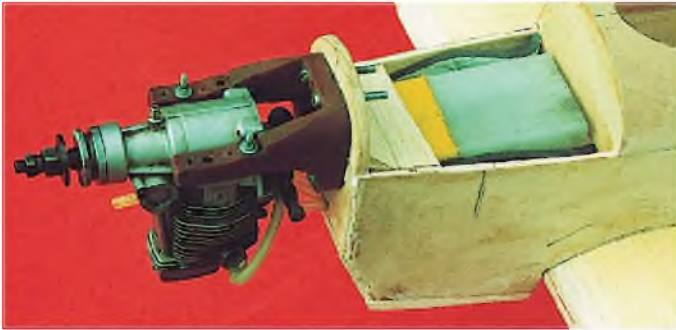

The inverted O.S. Surpass and the fuel tank installation.



Dual cockpit wells.



Underside view of the fuselage centre section, showing plenty of space for the radio installation.

ease of making front and rear decking from this wonderful material, with no worries about compound curves etc., became the obvious solution.

I soon had the tail pinned in place to measure the size of blocks necessary and was about to start hot-wire cutting, when Mike, my extremely knowledgeable 'about all things scale' mate and colleague, gently pointed out that that the tailplane incidence was wrong. Looking at it now, of course, the tail incidence is not along the top of the fuselage datum as I had fitted it - I knew that all the time - but having not picked up the plan for four years, and being in a hurry to finish it, I had inadvertently assumed otherwise - lesson; however well you think you know a prototype, check the plan! Following correction, it now sits at 1.5 degree (the wing incidence is 3°, giving the correct wing/tail/thrustline datums).

Cutting the foam now went ahead and it wasn't long before I was making a start on the wing fairings, fashioned from two laminations of soft 1/2" sheet. Within a week, the 'Mini Maggie' was ready for finishing - and was looking pretty good, even though I say it myself!

It then took me a further three weeks to complete the project - and went a bit

over the top for a model of the size - despite that, the weight didn't turn out too bad - 4lb. 13oz. - and suddenly, there she was, ready to fly!

FLYING

The O.S.48 Surpass provides more than enough power for the Maggie - too much, as it happens, because on the first flight, the throttle snake connector came loose at the servo and the larger part of the flight was spent hurtling round at full bore - at a most unrealistic pace - not that I was bothered with aesthetics at the time, I was more concerned about getting her down in one piece!

Finally, the motor revs dropped sufficiently to attempt a landing - not ideal circumstances for a maiden flight, but throughout, the Maggie handled the crisis with aplomb and despite an undignified nose-over, once down - it's one way to stop a runaway motor - she came out of it unscathed.

Having substituted the offending plastic clevis for a metal quick-link and satisfied myself that I had control over the full range of power, the second flight was, thankfully, without incident. At a more realistic gait, I was even able to appreciate just how good she looked in the air - the calculated CG position was

spot on (thank you again, Gordon Whitehead!).

The stall did show the desire to drop the left wing a bit, which is not uncommon, but she's not a full-house aerobatic machine anyway, so slow, flat, wide turns in the manner of the full size will present no problems.

I decided to practice a few landing approaches - I didn't want to press my luck too much after the first one - and was pleased just how stable she is in a slow, low pass, so much so that I did quite a few. She'll do mild aerobatics - wide loops, barrel rolls and lazy stall turns without complaint, but more than that, and you are on your own! All-in-all, a very pleasant lady!

Having flown her now in varying strength winds, I prefer to keep her for the more gentle breezes - she'll handle a stiff one - but being a small model, that thick wing is happier when not being blown about too much! The full-size was fitted with quite large flaps, but at this size they are an unnecessary complication. On application of power for take off, the tail comes up readily and she tracks straight, as long as she's right into wind - and flies herself off.

On landing, make a long steady approach, controlling the rate of sink with



Fully skinned foam core wing panel.



Magister airframe largely complete.

FIG. 1. AILERON HINGES

LITHO RECTANGLES CAREFULLY CYANO'D TO TOP SURFACE – NOT TO HINGE!

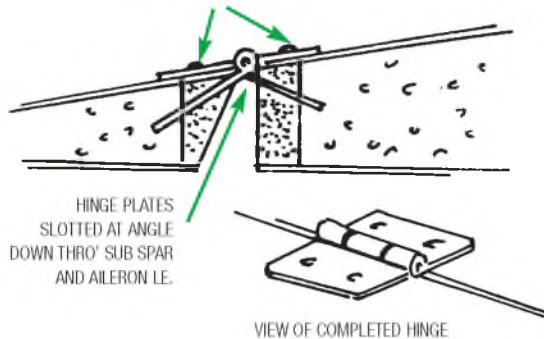

FIG. 2. WING FUEL TANK COVERS

CUT INSTRUMENT HOLE BEFORE CUTTING FINAL FLAP SIZE

THIN PLY FLAP PLATE

CLEAR ACETATE SHEET

PAPER FUEL GAUGE FACE

PIECE OF WIRE OR ALUM. TUBE TO REPRESENT HINGE

BLOBS OF PVA TO REPRESENT RIVETS

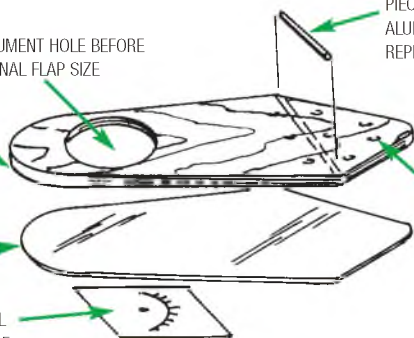

FIG. 3. U/C DETAIL

1: FIT WHEEL, BIND & SOLDER 1/2 AXLE TO LEG.

2: SPLIT & GROOVE DOWEL FOR STRUT LEG.

3: SLEEVE WITH TAPE, OR TUBE.

4: PLASTICARD SCRAP OLEO HINGED FORK

5: LITHPLATE FORK COVER.

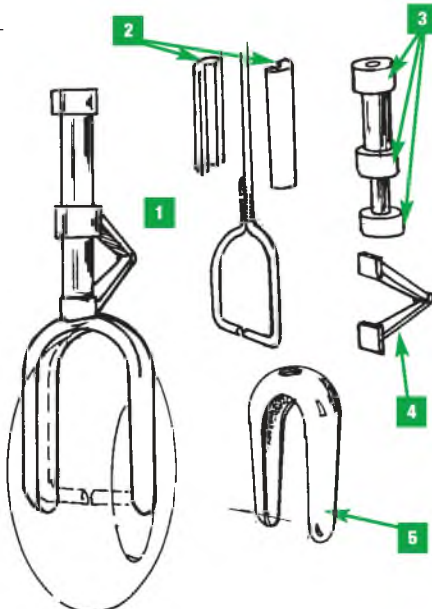

the throttle, and she'll virtually land herself - don't overdo the elevator trying for a three-pointer - two wheels is safer - she is a training aircraft, after all!

BUILDING AND DETAILING NOTES

Being very uncomplicated, the Maggie builds quite quickly and being on the small side, builds cheaply too. Details of a built-up wing are on the plan, but if you want to go the foam wing route, this is an available option with the Cut Parts set being offered here. So if an extremely quick build is your objective, then a foam wing is the way to go. If you decide to go with the built-up wing, don't forget to pack in that wash-out!

WINGS

Dealing with the wings first; no dihedral braces are fitted between the outer panels and the centre section. As I said earlier, it's a thick wing, so there is plenty of glue area for epoxy butt joints - gentle aerobatics have given no cause for concern with regard to the strength, and in the event of an untidy landing causing the wing to break, the break should be clean and easier to repair, without a brace. Make sure that the undercarriage mounting has good glue area contact. The ply plates sunk into the ends of the centre section support the ply/wire sandwich and should be made as large as possible, for the same reason.

Sink the aileron servo into the wing, to ensure clearance under the cockpit floor for the elevator/rudder/throttle servos which, incidentally, were fitted on their sides and not in the slots cut in the floor, as initially planned, and visible in some of the early build photos.

Keep the tail end light - careful wood selection is the order of the day, as you don't want to increase the wing loading on a small model, by having to fit

dead weight in the nose. I put the receiver battery on top of the tank, moved the fuselage servos to the front of the cockpit floor with the receiver behind, in order to get the fore/aft (CG) right - there is scope to move stuff around - but make it easier for yourself - keep the tail light!

The wing is covered in *Solartex* - olive green top, Cub yellow on the bottom, minimizing the amount of paint weight - if you go for an all-yellow scheme, you'll save even more, maybe! The wing tip blocks are quite large and, depending on the wood used, could vary in weight, when finished. The foam panels were pretty well identical on my set, but even so, check the wing lateral balance before covering and adjust with a metal screw or tip weight to suit.

Thin strips of litho were wrapped around the wing panel joint and epoxied in place after initial covering, to represent the full-size clamp strips - I even went as far as making little clips for the wing leading edge - a bit unnecessary at this size.

The other major surface detail feature of the wings is the fuel tank access caps and gauges, the non-slip walkways and the aileron hinges. On the full-size, these are somewhat prominent and even at this size, some attempt at reproducing them should be made.

The ailerons are top hinged with simple pinned hinges. On the full size, the plates were screwed onto the top of the wing and aileron surfaces, so I used standard pin-hinged plastic hinges, slotted into both wing and aileron at a downward angle from the top surface, with the pin raised above the wing surface.

After final assembly (after covering, but before any painting), I made up some rectangular plates from thin litho, punched them from the rear to represent the screw heads, then cyanoed these to the aileron

and wing right up against the raised pin hinges. The pin hinges were oiled before the application of the cyano to prevent getting glue in them and minute drops of cyano applied, using the sharp tip of a cocktail stick. The result? Very effective!

The fuel tank covers were cut from thin ply, with a piece of thin aluminium tube cyano'd in place to represent the flap hinge. The fuel gauge is a paper face suitably sized on a photocopier (like all instrument gauge faces) and stuck to a piece of acetate underneath the ply flap, aligned carefully with the hole (tip - cut the hole in the ply first, then cut-out the flap! Cover the acetate with a piece of sticky tape (use a hole punch) to protect the clear face from paint and glue on after covering.

Wing walkways are the usual fine grade abrasive paper, with *Plasticard* strip surround pieces. Don't leave them pristine - get some dirt on your finger and rub it into the abrasive - but don't over do it and take your skin off!

UNDERCARRIAGE

The undercarriage must be strutted and fitted with struts, oleo links and brake cables - it wouldn't look right otherwise - unless of course you choose to model an example of the Maggie that was fitted with spats, but my advice is - forget it! Take the time to tart up the bare legs and you will be adding greatly to the overall character of the Maggie - if you don't bother, and it's just another model! I used hardwood dowel, split in half and grooved, paper tape to change the strut diameter as appropriate and worked some annealed litho plate into the wheel covers.

The oleo hinges are from *Plasticard* and scrap tube - I was joking about the brake cables!

NATIONAL INSIGNIA AND DETAILING

If you don't fancy painting those big roundels, I'm sure that *Flightline Graphics* will sort you out some at the right size. I used an ink compass, matt *Humbrol* enamels and a 1/4" flat brush!

The fuselage gives quite a lot of scope for detailing, but first, if you use ply sheet or foam blocks covered in brown parcel paper, as I did, then achieve a smooth surface first. Again, I covered mine with olive and yellow *Solartex*.

To get a straight join line, I fitted the yellow sides and then the bottom, leaving the top edge of the sides about 3/8" oversize and not stuck down. The green top was fitted (I managed it in one piece, but if you prefer smaller, then do it in three and start at the rear, moving forward), and a similar overlap left unstuck. A metal straight edge was then laid carefully over the two layers of overlap, checking that the edge to be cut matched the colour line in the documentation photos and, with a new blade fitted in your scalpel, cut along the edge of the rule, through the two layers of covering.

FIG. 4. COWL DUMMY FASTENERS.

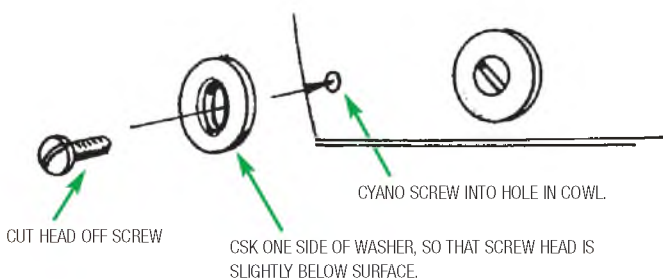
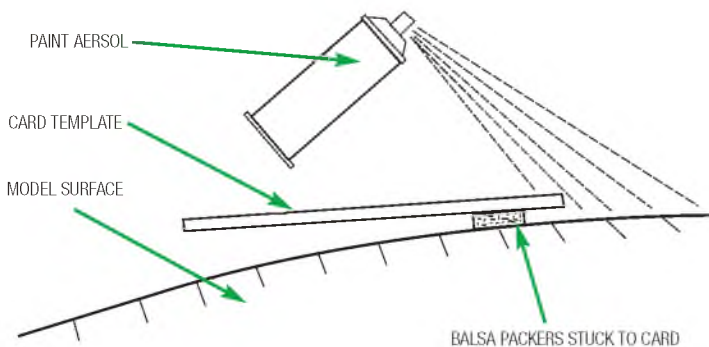

FIG. 5. GETTING CORRECT OVERSPRAY WIDTH.



CUT PARTS SET FOR THE

MILES M.14 MAGISTER

Get straight down to construction without delay!

This plan feature is supported by a laser-cut set of ready-to-use balsa and plywood components. This provides wing ribs, wing trailing edges, braces, struts, fuselage sides doublers formers, etc. that, otherwise, you would need to trace out onto the wood before cutting out.

IT DOES NOT INCLUDE STRIP AND SHEET MATERIAL OR SHAPED WIRE PARTS

TWO OPTIONS WOOD OR FOAM-CORE WING?

With wood wing:

Price £85.00

plus carriage: £11.50 (UK); Europe £26.00

INCLUDES: Fuselage sides, doublers, formers, fin and cowl parts and tailplane, fin, rudder. Wing ribs, joiners and undercarriage location.

Order set **CUT/FSM 250 (Wood wing)**

With foam core wing:

Price £110.00

plus carriage: £11.50 (UK); Europe £26.00

INCLUDES: Fuselage sides, doublers, formers, fin and cowl parts and tailplane, fin and undercarriage location, plus veneer skinned three-part foam core wing.

Order set **CUT/FSM 250 (foam wing)**

Shipping Note: For shipping to destinations outside the UK and Europe, you will be charged our standard flat-rate price of £49.

This covers most destinations and secures your order with us. However, we will contact you accordingly with an accurate total shipping charge prior to dispatch and either issue a refund or a PayPal money request for the balance.

Visit our secure website:

www.flyingscalemodels.com

to order yours



Order direct from:- ADH Publishing, Doolittle Mill, Doolittle Lane, Totternhoe, Bedfordshire, LU6 1QX, UK. Tel: 01525 222573/ enquiries@adhpublishing.com.

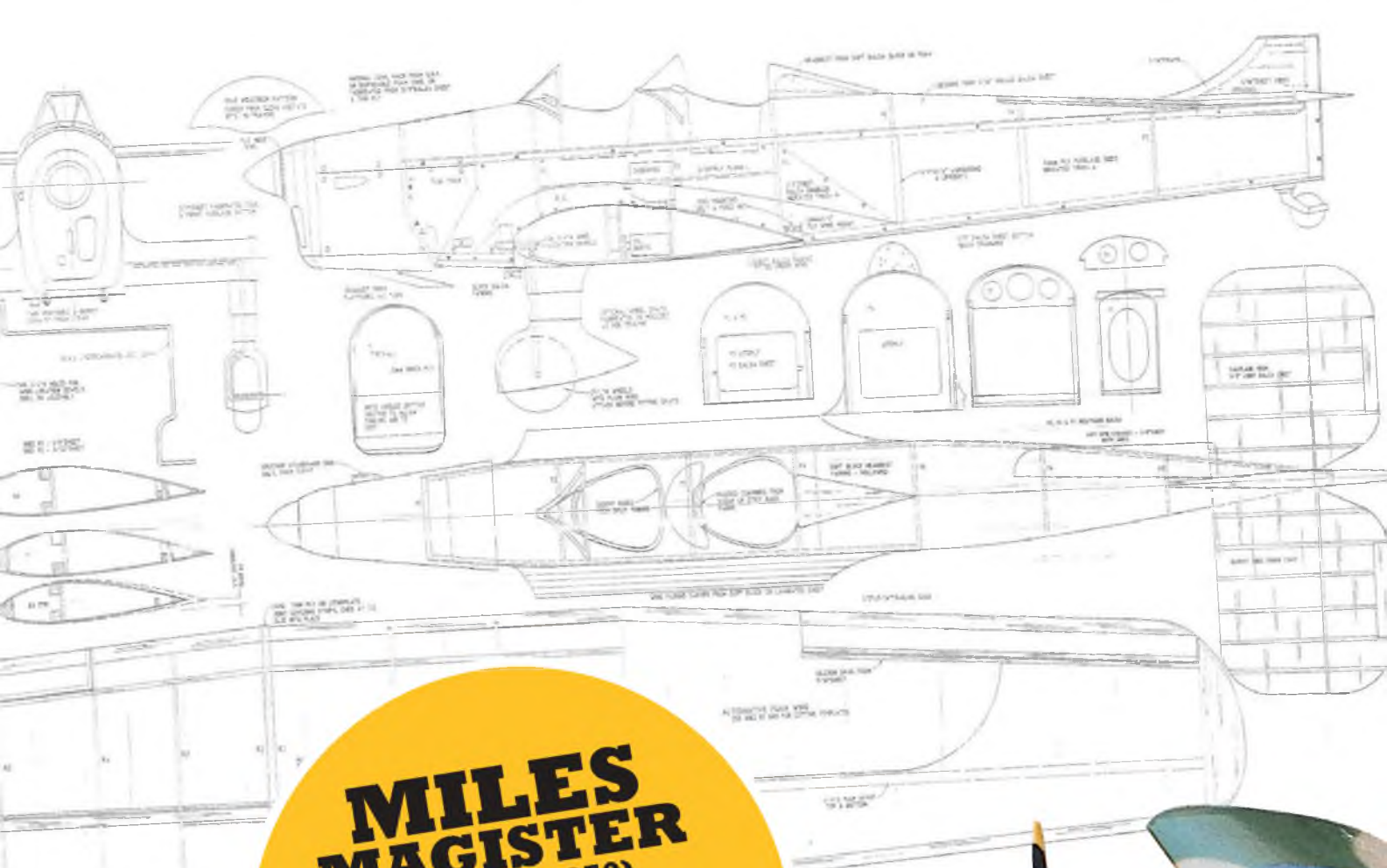

MILES MAGISTER (PLAN FSM 250)

Full size copies of this plan are available from Flying Scale Models Plans Service, ADH Publishing, Doolittle Mill, Doolittle Lane, Totternhoe, Bedfordshire, LU6 1QX. Tel 01525 222573 enquiries@adhpublishing.com

Price £13.50 plus p&p
(U.K. £2.50; Europe £4.00;
Rest or World £6.00.

Don't press too hard; even though the fuselage side is ply, you don't want to cut it. Remove the cut off overlap and the two edges of *Solartex* should butt perfectly.

Now, using a cool iron, seal the edges. You must check the temperature of your iron on a scrap piece to set it at as low a setting as will just activate the adhesive. Anything higher will shrink the fabric and open up a gap - don't guess, use a test piece and if you have to adjust the temp., then let the iron settle down before checking again. Of course, if you have chosen the all-yellow scheme, the last 200 words don't apply!

Main features that have to be reproduced on the fuselage are two pilots (they help to hide the lack of cockpit detail) - as a joke,

I've tried to show a firm-jawed instructor in the rear seat, and a pale-faced pupil in the front seat, peering over the cockpit coaming. Also plainly visible are the instrument panels - there's been any number of articles on how to make those! Port side-mounted venturi heads (litho, alum. tube. or dowel); cockpit entry doors and luggage bay door (stbd side). I used thin plasticard strips for the cockpit door-frame surround pieces, feathering the edges to fair them in). The luggage door is just a rectangle of brown parcel paper, covered in *Solartex* and just stuck on, with a couple of pieces of wire on the top edge for hinges, and a couple of *Plasticard* clips at the bottom.

Wing fairing attachment bolt heads are little blobs of PVA; don't make them too big, and make the spacing even, it looks better.

The one-piece glass cowl can be worked quite easily by cutting the various panel lines with a fine saw and a cut down hacksaw blade, for different size gaps, making sure the lines are straight and symmetrical. Air scoops can be

made with annealed lithoplate, even at this small size - just keep re-annealing often, to prevent cracking.

The Camloc/Dzus cowl fasteners of the full size are worth replicating, as these are quite large. I managed to find some slot-headed csk screws just the right size and lightly csk one side of some similarly sized washers then drilled the cowl in the appropriate positions and stuck the screw heads/washers with epoxy (four of them actually hold the cowl on). When painted, the paint blends out the sharp edges very effectively. I had hoped to fit a bendy pipe exhaust pipe for the O.S. Surpass, to avoid cutting a hole in the cowl side, but it was not practical, so I cheated by



taking the photos of the completed model, before committing the sin of cowl surgery. The aluminium tube exhaust pipe is a dummy, naturally.

FINALLY, THE TAIL SURFACES

These are the only fabric covered surfaces on the full size, so emphasise it by fitting rib tapes. Get a piece of both green and yellow scrap *Solartex*, with the weave running along the length of the fabric and long enough for the tail chord and with scissors or a blade cut a series of small nicks along the top edge, spaced equivalent to the width of the tapes (approx. 3/16").

Now tear off the individual strips - don't cut them, tear them - this gives a 'frayed' look to the edges. Tack-iron them on at leading and trailing edges, making sure that they are straight and exactly on each rib position, then iron them in place - simple.

The model flies on an 11 x 6 prop, but for appearance sake, I've made a scale prop and spinner just to finish it off.

Paint

Even using *Solartex*, some painting will be necessary, of course. I used matching *Flair Spectrum* paint to touch up any areas of



SQUARE-JAW & WHILE KNUCKES! Instructor at the rear and trainee in front. Other details visible here include, wing-tread patch, fuel tank access hatch, air scoops and dummy exhaust pipe.

olive green that were needed, including the detail parts and wing fairings. The brown is a car aerosol spray - not exactly accurate, but near enough. It is also fuel proof (at least to 5% glow fuel) so final fuel proofing can be kept to a minimum. The narrow overspray between the green and brown is achieved by making up a number of different-shaped, curved-edge card templates, and fitting 1/8" pieces of balsa packing around the underside of

the curved edges, then laying the templates on the wing and tail (and taped around the fuselage) over the green areas and carefully spraying with the aerosol away from the card edge, from green to brown - never brown to green - again, make up a test piece, or practice on an old model - you'll be surprised how easy it becomes - and how effective it looks, after a few tries. ■



MILES MAGISTER

TYPE
HISTORY
AND
CLOSE-UP
DETAIL

Until Fred Miles met up with Charles Powis at Woodley, near Reading in the early 1930s, the Miles sporting aircraft enterprise at Shoreham had been held together with, as much as anything, 'shoestring enthusiasm'. But with the availability of a bankrupt stock of suitable aero-engines, F. G. Miles created the M.2 Hawk, a sports,

touring and club training low-wing monoplane. The prototype first flew in March 1932 and was so well received by pilots that no fewer than 22 variants were turned out in the new venture at Woodley, established by Charles Powis and his partner, as Phillips & Powis Aircraft Ltd.

The M.2 Hawk (see FSM August 2015) developed into an eye-catching profile of

tandem-seat streamlined neatness from the slim-cowled inverted inline and smartly trousered main undercarriage to the characteristically 'Milesian' fin-and-rudder shape so noticeable in all the designs up to the M.17 Monarch. The exceptions, tail-wise, were both to be production versions of trainers for the Royal Air Force, the two-seat advanced trainer M.9A Master Mk.I and the military elementary trainer, the

Cockpit windshield detail on P6382. Note different shapes of front and rear shields.



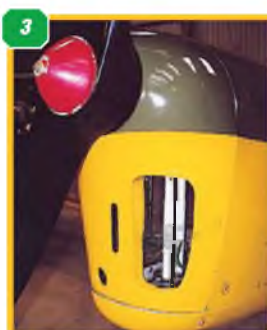

1: The Shuttleworth Collection's machine P6382 at Old Warden is one of the two examples in this photo-detail feature. 2: The line of the engine cowl viewed from across the starboard wing. 3: The nose, showing the panel lines and air intake. Note the size of the panel fasteners. 4: A further view of the cowl from the starboard side. 5: Head-on view of the nose showing the exhaust exit.

M.14A., officially named 'Magister' from April 1937.

The Magister had a far better overall performance than any elementary trainer then in use and with its low-wing monoplane characteristics and split flaps, it reproduced in a safe manner the handling techniques associated with the new Service aircraft, deliveries of which were then starting.

The Magister has long been a scale modellers' favourite and that's no surprise. It offers a simple, uncomplicated shape, just the one set of wings, fixed undercarriage, ample wing area and good nose and tail moments.

It was an aircraft of the WW2 period and served along side the DH Tiger Moth, in comparison to which, it offered higher airborne speed but, surprisingly, lower landing speed.

Responding to an Air Ministry requirement in 1936 for an elementary

trainer, to prepare trainee pilots for the new monoplane fighters and bombers then beginning to enter service, the Miles Aircraft Company was not much pressed to develop the Magister as an extension of their Hawk Major, which itself was an extension from the Miles M.2 Hawk.

Dual controls, full blind flying equipment, vacuum operated flaps and wheel spats resulted in the Miles M.14A - the 'Maggie' was borne.

However, initially at least, the Maggie was by no means the perfect training aircraft, demonstrating spin characteristics that made recovery rather difficult... not exactly the kind of thing an embryo pilot needs.

Because the aircraft was so close in general specification to the earlier civilian Miles Hawk trainer from which it was developed, no definitive prototype example had been produced. Eventually, wind tunnel tests demonstrated that the

enlarged rear cockpit of the Military type, with its blind flying hood, disrupted airflow over the tailplane. To cure the problem, the horizontal tailplane was raised 6 inches, fairing into a flat rear fuselage top deck with strakes on either side fairing into the tailplane root. A taller fin was also applied.

Later, further modifications followed as result of experience at the flying schools. The tailpost mounted tailwheel was moved forward onto a bulkhead a few inches further forward and the original two-piece engine cowl was replaced with a more sturdy three piece unit, while the original rear cockpit windshield was replaced by a rounded one-piece type.

Generally, the Magister was well liked by those who flew it, offering positive reaction to control movements which allowed trainee pilots to quickly appreciate the effect the three primary control. Ailerons in particular, were

6



7



8



9



10



11



12



- 6: Further view of the cowl nose section.
 7: Port side of cowl. Note panels and fasteners.
 8: Rear line of cowl viewed from Port side.
 9: View of the rear underside of the cowl where the air exists.
 10: Panel detail on port side of fuselage at the rear cowl line.
 11: Underside of the fuselage, just behind the cowl line. Note quick-release fasteners.
 12: Further general view of the cowl, viewed from the Starboard side.

quite lively.

Many thousands of WW2 aircrew experienced the Maggie, which also saw much service as a Squadron communications aircraft.

However, for all that, and the fact the many examples found their way, post-war, onto the civil register, civilianised by Miles as the Hawk Trainer III, the type has not established itself in the nostalgic minds of aviation enthusiast as has its contemporary, the Tiger Moth. None of that detracts from its appeal as a scale modelling subject, made easier by the fact that in many cases, the spatted undercarriage was removed, leaving its spindly main undercarriage legs dangle in the breeze.

Like some many aircraft of the WW2 period, the Magister had its fair share of being a test vehicle. With the threat of invasion in the summer of 1940 'Maggi bombers' were created at the Woodley factory by installing light bomb carriers (up to eight 25lb. bombs) under the wing centre section. Fortunately, this 'last-ditch' anti-personnel ploy never had to be implemented against the anticipated German invasion force of 1940.

Aerofoil devices were also tried and there were at least two devilish attempts to make young pilots old before their time. There was the McLaren Cross-Wind Undercarriage and then there was a fearsome Towed Wing experiment of 1941 whereby slots were cut in the mainplanes to permit narrow booms to be anchored. Suitably wire-braced, these booms extended beyond a considerably enlarged rudder to an even larger twin-tail assembly. The idea was to use this

13





Two views of the cockpit interior, viewed from the Starboard side towards Port.



13 & 14: Two views of the tailcone. Note the unshrouded hinge lines and anti-spin strakes.
 15: Top surface aileron hinge, reminiscent of typical sport R/C model!
 16: Tie-down point on wing underside.
 17: Corresponding retainer plate on wing top surface.





18: Elevator trim tab. **19:** Close-up of the tailplane/elevator showing the hinge line and hole through fuselage for the elevator joiner. **20:** Panel detail at wing leading edge above the main undercarriage leg. **21 & 22:** two views of the main undercarriage leg. Wheel pants were regularly removed at the training establishments. Operating from grass fields, the wheel pants tended to collect mud inside, eventually build-up of which could result in risk of nose-over. **23:** The steerable tailwheel unit.

ghastly arrangement to carry bombs or fuel to extend ferry range.

By comparison, the occasional post-war lapses into cockpit enclosures and even smaller transparencies for racing purposes seem nothing more than delightful flights

of fancy.

With all the initial deficiencies resolved though, the 'Maggie' became a popular aircraft with those who flew it and appreciated its handling characteristics, as exemplified by the demonstrations of F.G.

Miles' brother George

who frequently landed a Magister with both hands above his head; and by Bill Skinner, the chief test pilot, who used to formate on other aircraft while flying the Magister inverted!

The windshield on T9738.





24: Similar view from the Port side. 25: Close up of cockpit interior showing the compass mounted on the Starboard side. 26: Rear of the front cockpit. Note the internal bracing members. 27: Similar view of rear cockpit. Bracing members are different. 28: View of cockpit interior showing the access door. 29: View down the fuselage showing the anti-spin strakes.

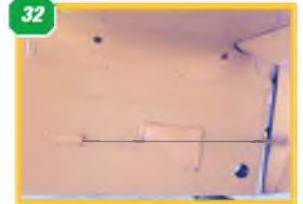
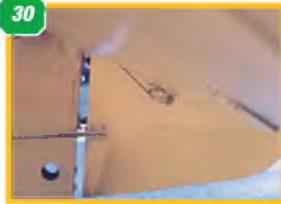

30: Under the tailplane at the tailpost showing rudder closed loop control and elevator trim tab control. Note the gap between rudder and tailpost. 31: Rudder control horn and linkage. 32: Panel detail under tailplane. 33: Engine cowl of T9738 is different from the Shuttleworth Collection's example. 34: View backwards, behind the cowl underside in T9738 again a bit different from P6382. 35: Fuselage side detail. 36: Close up of the top surface mounted aileron hinge. 37 & 38: Detail of the fuel tank filler points one on each wing. 39: Wing root showing the wing-walk strip on the Starboard side.



MILES MAGISTER FLYING COLOURS

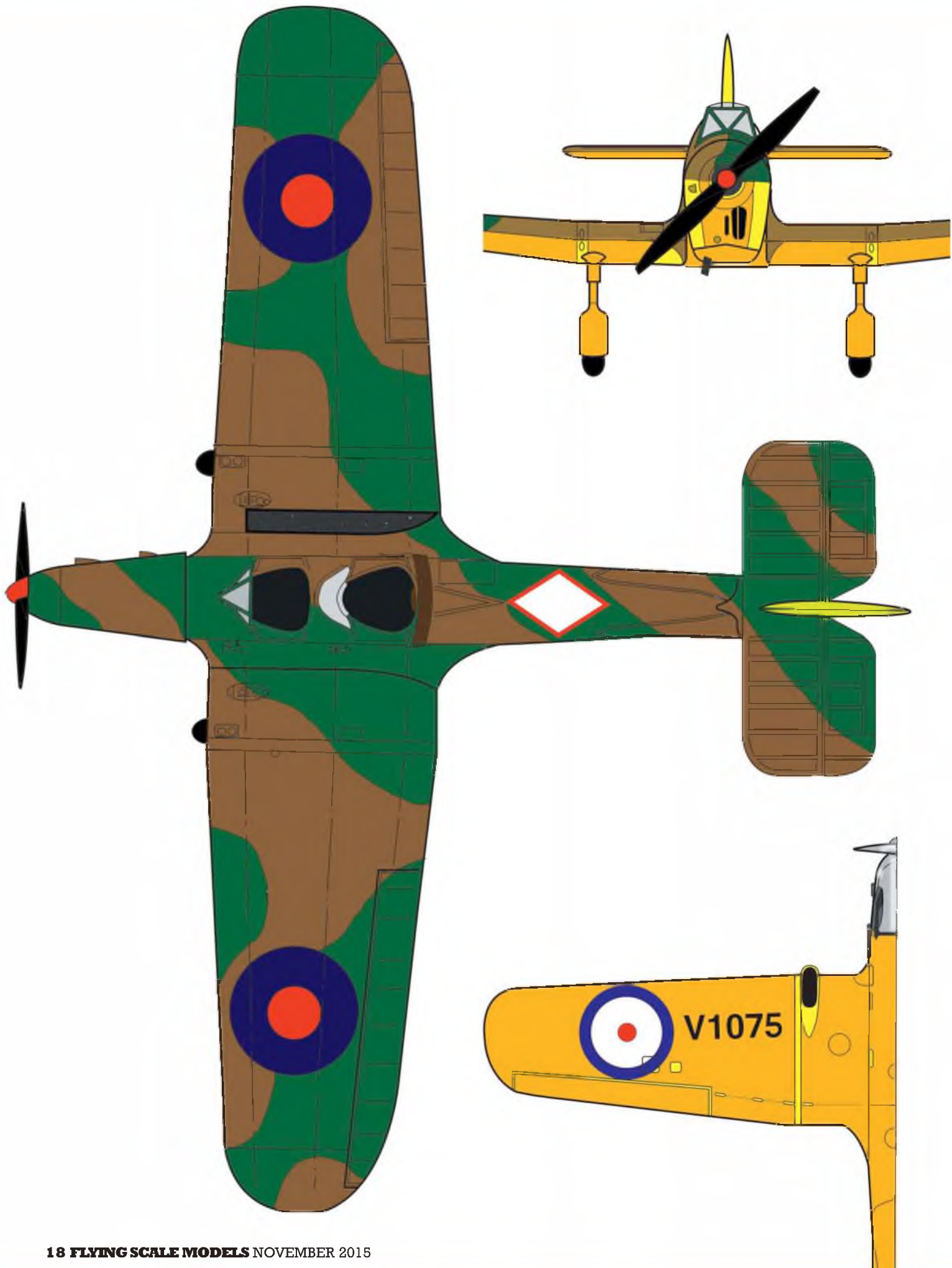

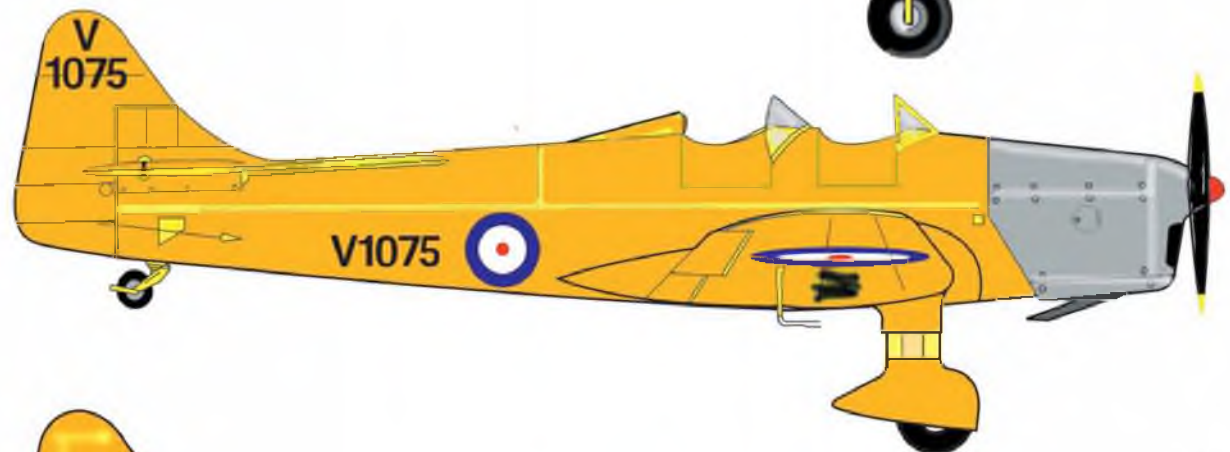
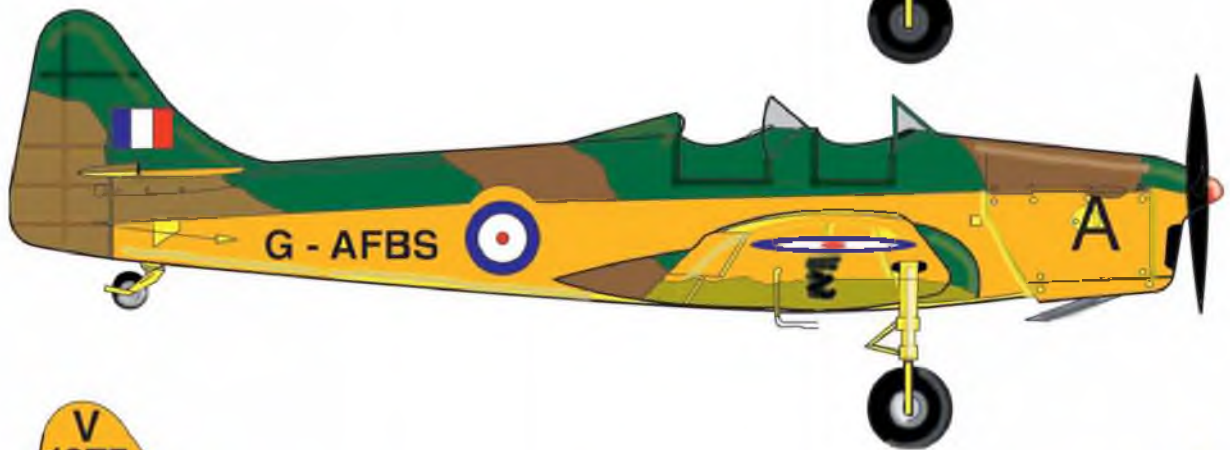

MILES M.14 MAGISTER

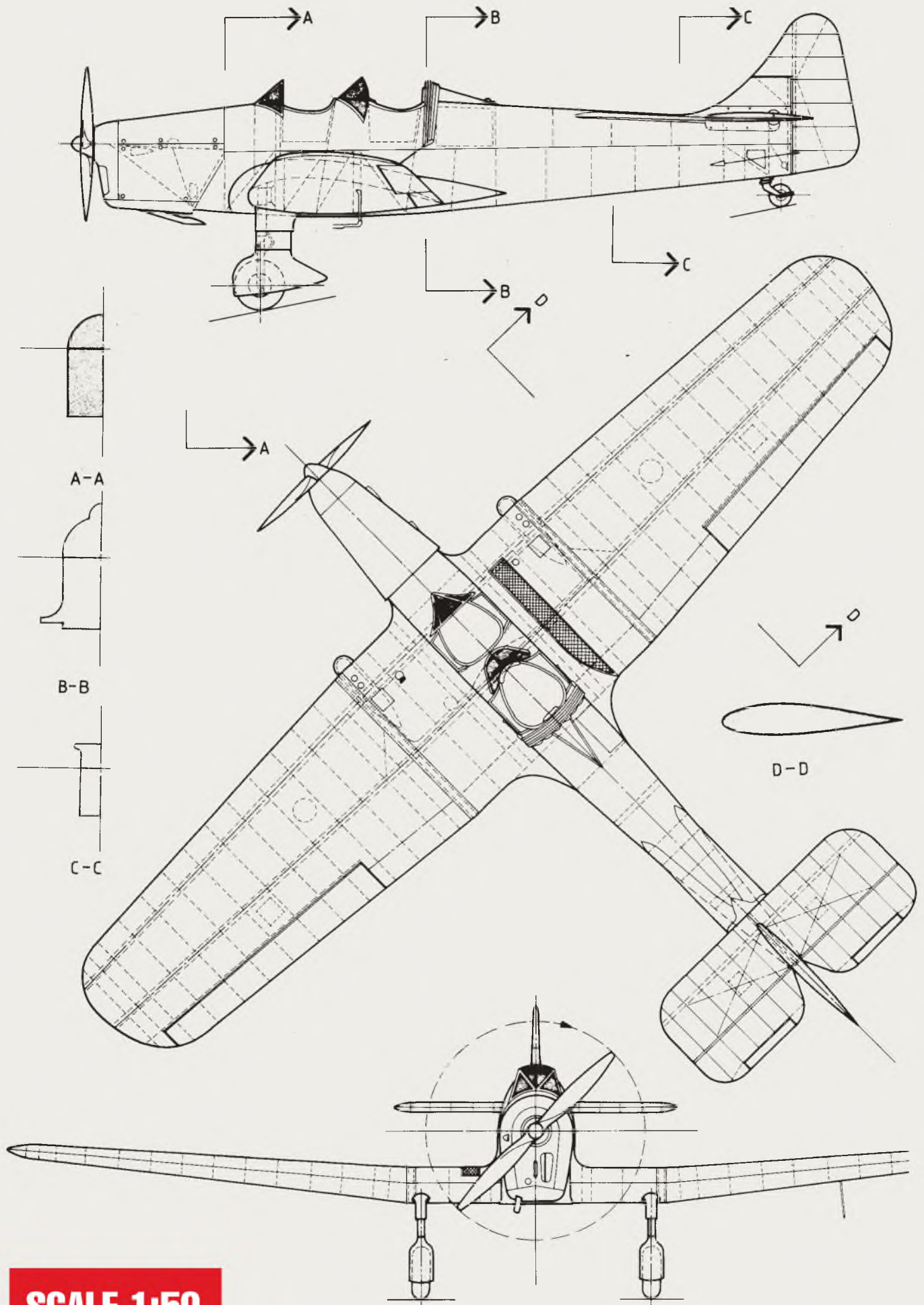

SCALE 1:50

Gildings Annual Aero Engines Auction
 Saturday 7th November 2015 at 10:30am

Vintage Model Aero Engines including early FROG Single Seat Fighter RTF, Single Seat Fighter RTF, rubber model, "Buccaneer", "Puss Moth", Model Aircraft. Modern engines including Apex Minor 15cc FS, and early kits including AEROMODELS De Havvilard Dragon, Westland Lysander, Miles Magister, Hawker Wind...

Viewing
 Fri 6th Nov 10am-4pm
 Sat 7th Nov 9am-10:15am

Enquiries
 Dick Roberts (consultant)
 01858 410414
 sales@gildings.co.uk



APEX MINOR 15cc FS - Est: £300-500

GILDINGS.CO.UK

gildings
 auctioneers

MARKET HARBOROUGH SALEROOM
 THE MILL, GREAT BOWDEN ROAD, LE16 7DE
 T: 01858 410414 SALES@GILDINGS.CO.UK

LASER IT!

From Only
£24
 +P&P



- Get your plan precision laser cut
- High quality materials included in the price
- Simple online ordering
- Know the price before you order



To Order Goto
www.braincube-aero.com
 or call **0845 459 3174**



VISIT THE ROTORWORLD WEBSITE

ALL THE LATEST R/C HELI ONLINE NEWS & MUCH MORE IS JUST A CLICK AWAY!



- LATEST NEWS
 - REVIEWS
 - FEATURES
 - GALLERY
 - VIDEOS
 - EVENTS
 - LINKS
- AND MORE...

ORDER ONLINE

MANAGE YOUR SUBSCRIPTION, ORDER ISSUES, BINDERS, BOOKS, SUNGLASSES...

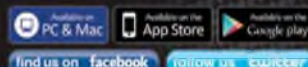

find us on [facebook](#) follow us [twitter](#)

MAKE SURE YOU VISIT US AND BOOKMARK
WWW.ROTORWORLD.CO.UK

DB SPORT & SCALE LTD

RADIO CONTROLLED MODEL AIRCRAFT KITS AND ACCESSORIES



NEW CLICK & BUY WEBSITE WWW.DBSPORTANDSCALE.COM
 TEL: +44 (0) 1792 897501 EMAIL: SALES@DBSPORTANDSCALE.COM

Vintage Limited Edition Prints



visit: www.aeromodels.com for the full range



Vintage AeroModeller A3 Cover Artwork - Limited Edition Print

Snafu

Comp ARF P-47D
Thunderbolt

Alex Whittaker admires a superb model,
debuted at LMA Cosford 2015



Note wide track undercarriage,
Sierra retract, and four-blader
carbon paddle prop.

The Republic P-47 Thunderbolt needs no introduction to flying scale modellers. She is easily one of the most modelled scale subject on the UK warbird circuit, and always has a good showing at Club scale meetings. The growth in the availability of large modern composite scale kits, and the runaway success of the Moki 250 / five-cylinder scale radial petrol engine has seen a further explosion in Thunderbolt numbers. Thunderbolts look impressive and fly well, and those big radial engines and eye-catching WW2 USAAF schemes confer a certain 'Combat Theatre' glamour. Mind you, imposing European-Theatre Jugs with bold Invasion Stripes have a certain comeliness all of their own!

Jug

No WWII fighter powered by a single i.c.

engine weighed more than the Republic Thunderbolt. Her big sassy looks gained her the nickname 'Jug', or 'Jugernaut' - a reference to the type's ability to build up speed in a dive! Her armoured cockpit, 2000hp Pratt & Whitney engine, and devastating eight-0.5" firepower, made her a potent fighter as well as a formidable ground attack platform.

Her highly innovative plastic-impregnated paper composite drop tanks were a very clever tactical accessory. Although they were leaky after only a short time, they lasted long enough to get the Thunderbolt up to operational height. These cost a fraction of metal tanks to make, increased the Thunderbolt's range,

and disintegrated on impact. Thus they were useless once dropped, could not be recycled, and thus offered no advantage to a scavenging enemy. What many military commentators overlook is that the Thunderbolt was appointed with a very comfortable pilot's seat, and was even fitted with air-conditioning! Despite her weight and bulk, she was an extremely potent weapon. On front line service in Europe, later mark Thunderbolts accounted for 20 enemy Me 262 jets and four Arado Ar 234 jet bombers.

The Jug had a reputation for toughness, plus the uncanny ability to get her pilot home safely, even when badly shot up thanks to a tough airframe and it's air

“The Jug had a reputation for toughness, plus the uncanny ability to get her pilot home”





- 1: Sliding canopy is an option.
- 2: Complete down to the rear view mirror.
- 3: Scale hinges, scale hinge lines, and hidden control horns all build the illusion of reality.



cooled Pratt & Whitney radial engine which was devoid of the susceptible coolant systems which inline engines relied on. Over fifteen thousand Thunderbolts were built. Examples remained in service with the US Air National Guard well into the 1950s. Some overseas variants sold to Peru remained in service until 1963.

The Model

The model was built by Tim Simmonds and is owned by David Pearson. It is built from the celebrated Composite ARF P-47 Razorback kit and plan. It is designed to 1:4.5 scale, which produces a wingspan of 112". She weighs 52lbs, and is powered by the now legendary Moki 250cc /five-cylinder radial. In fact, the model is designed around the Moki powerplant,

delivering a very accurate look to the cowling. The kit takes account of the weight of this prime mover, and has an optional radio equipment tray to move the cg aft.

Construction

Construction is of the modern 'Composite GRP and Carbon Fibre' formula, with additional ply formers and hard points. The fuselage is supplied ready-built with the wing mounts, firewall, and all mounting provisions in place for the designated Moki radial. The rear rudder servo mount, the fuel tank mount, and the radio equipment tray are either built in, or ready-prepped to just bolt in. There is also provision for the cockpit anopy lines, sliding canopy rails, and a full vacuum-formed cockpit kit. The wings are all-

CAD-derived proportions look just right. Finish is traditional cellulose paints.





Snafu looking resplendent in her Invasion Scheme, and parked out on the grass.

moulded and accommodate the landing-gear hard points, and the scale Fowler flap and hinge system. Flap servo mounts are built in, too. Control horns are hidden. The bolt-on all-moulded tail has provision for hidden controls, retractable tail gear, and scale hinges. The supplied all-moulded cowl completes the airframe.

Engine

Moki 250cc / 5 Cylinder Radial petrol engine.

Prop

Carbon fibre (ground-adjustable pitch) 4-blader: 30" or 32" diameter.

Exhaust

The Moki collector ring, from the 5 cylinders, exiting in the correct scale position.

Undercarriage / Retract

Sierra Precision made in the USA. This

undercarriage is a bespoke extra for this model. The struts compress on retracting. The clever partial air retract system allows the aircraft to settle low onto its wheels, as would the full-size on losing pressure, when the engine is turned off.

Covering

Composite GRP, painted in cellulose matt paint. David is considering his weathering options, which he might



4: This model was designed around the famed Moki 250cc / 5 cylinder petrol radial engine. **5:** Exquisite scale-finish variable-pitch carbon prop, hub, and spinner. Pitch can be altered on the ground. **6:** Mail undercarriage inner door. **7:** Superb Sierra Retracts sag like the real thing at rest. See text. Full size aircraft main U/C legs would foreshorten by 9" during retract sequence: difficult to reproduce in miniature.





8: Germany's Tailor Made Decals produced the stencils, paint masks, and decals. **9:** Outlet vents all present and correct under the Invasion Stripes. **10:** Note retracting tailwheel's doors. Note also graduated paint overlapping of the main scheme.

The Composite ARF Thunderbolt P-47 builds into a magnificent 1:4.5 flying scale model.





11: Supplied wing panels have all the scale surface details moulded in. **12:** Fowler type flaps drooped for the camera. Note flap-degree verniers. **13:** Four .50 calibre cannon per wing. **14:** Crisp control surface hinge details throughout the model.

apply over the coming winter building season.

Painting

The model depicts The Fighter Collection's P-47, painted to represent 'Snafu'. This was the

aircraft flown by Lieutenant Severino B Calderon of the 78th in late 1944, to take on Luftwaffe fighters and escort Allied heavy bombers.

Legending / Decals

Germany's Tailor Made Decals





15



16



17



18

15: Very crisp legending throughout.
16: Kill decals painted over the servicing legending. Correct!
17: Tailor Made Decals represent Snafu flown by Lieutenant Severino B. Calderon.
18: Moulded-in detailing and hinging continues in the tail group.

SPECIFICATIONS:

Republic P-47D Thunderbolt

- Scale:** 1:4.5
- Wingspan:** 112 inches
- Weight:** 52 lbs
- Retracts:** Sierra Giant Scale
- Engine:** Moki 250cc 5 Cylinder Radial
- Exhaust:** Moki collector ring
- Prop:** Carbon fibre ground-adjustable pitch paddle 4-blader, 30" or 32" diameter

supply the stencils, paint masks, and decals.

Scale Details

The model has scale operating Fowler flaps, a sliding canopy, and pneumatic air damping on the undercarriage legs.

Flying Notes

David reports that, as with nearly all P-47s, she flies very well: "In truth she would be grossly over powered with the Moki

engine if pushed too hard. Better to fly her in a scale fashion. She is very stable and strong winds do not seem to bother her. Having flown both this model, and also the Composite ARF F4U Corsair, I would say the P-47 Razorback flies better".

Kit Details

<http://carf-models.com/en/products/p-47-razorback>



The Composite ARF Thunderbolt is 112" in span and weighs 52lbs.

NEW in the 'HOW TO BUILD...' series



NOW AVAILABLE
Order Now

NEW How to Build the Tamiya 1:32 Mosquito FB.VI

The definitive guide to building the much anticipated Tamiya 1:32 Mosquito FB.VI by Brett Green.

This book features a comprehensive build plus:

- Mosquito restoration close-up
- Historical summary
- Wartime reference photos
- Step by Step - Tips and techniques for building the ultimate Mosquito
- The other Tamiya Mosquitos in 1:72 and 1:48 scales
- Aftermarket decal and accessory summary

NOW SHIPPING

Only
£13.95
plus p&p

ALSO AVAILABLE Visit adhbooks.com for details



PLACE YOUR ORDER NOW ON **TEL: 01525 222573** **FAX: 01525 222574**

Tamiya's 1:32 Mosquito FB.VI book

HOW TO BUILD... MOSQUITO

Name.....
Address.....
Post/zip code.....
Country.....
Telephone Number.....

Please debit my credit/debit card for £.....
 Visa Mastercard Maestro other.....
 Card No.....
 Expiry date..... Start date.....
 Security Number (last 3 digits on signature strip).....
 Issue No (if applicable).....

P&P: UK: £2.00
 Europe: £4.00
 World-Wide airmail: £6.00
 Cheques payable to: ADH Publishing Ltd.

Signature.....
Date.....

Please mail this form to:
 ADH Publishing, Doolittle Mill, Doolittle Lane, Totterhoe, Bedfordshire, LU6 1QX, United Kingdom
Tel: +44(0)1525 222573 **Fax:** +44(0)1525 222574 **Online:** www.adhbooks.com
 (Photocopies of this form are acceptable)

www.adhbooks.com www.adhbooks.com www.adhbooks.com

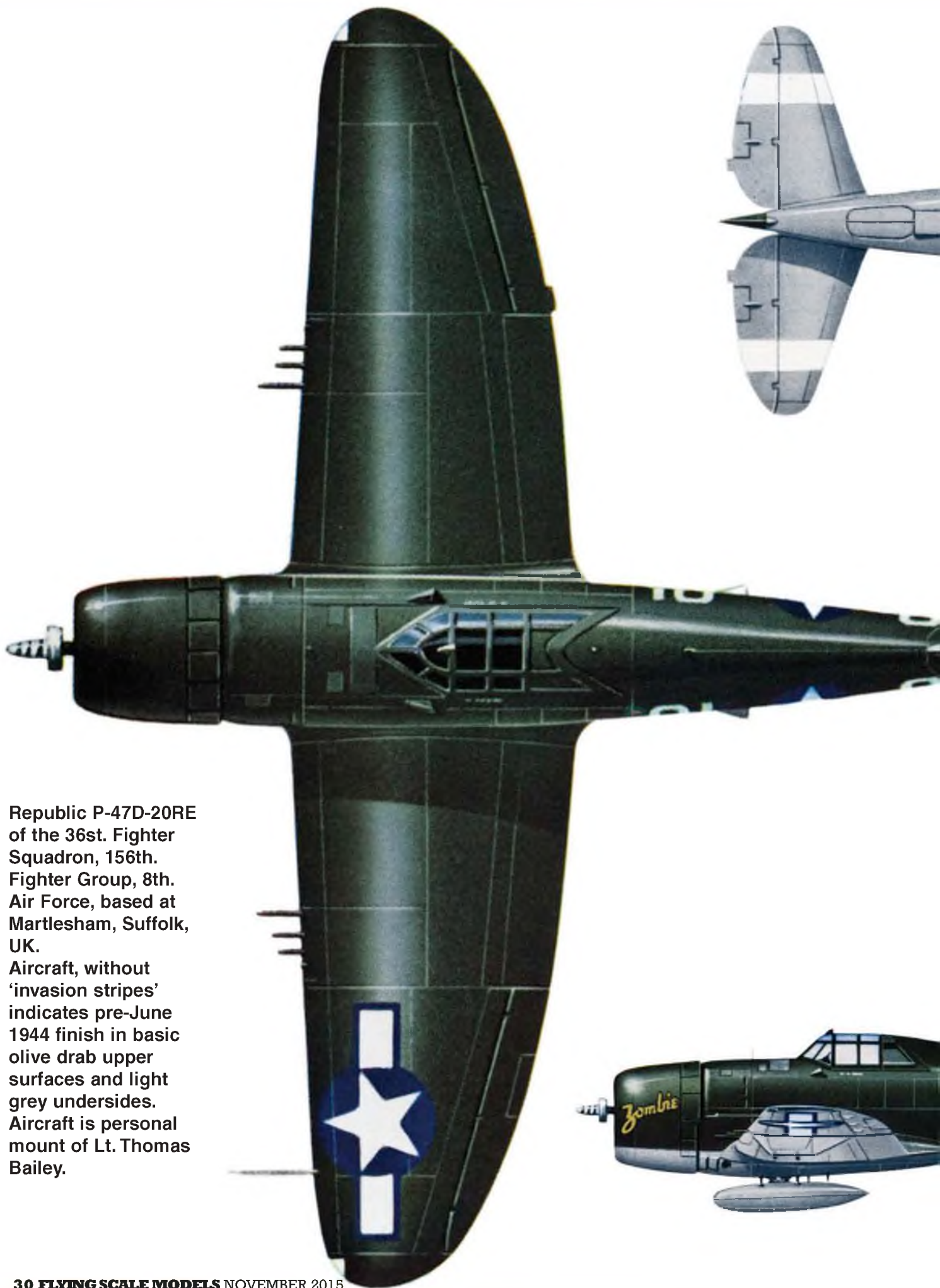

Republic P-47D-20RE of the 36st. Fighter Squadron, 156th. Fighter Group, 8th. Air Force, based at Martlesham, Suffolk, UK.

Aircraft, without 'invasion stripes' indicates pre-June 1944 finish in basic olive drab upper surfaces and light grey undersides. Aircraft is personal mount of Lt. Thomas Bailey.

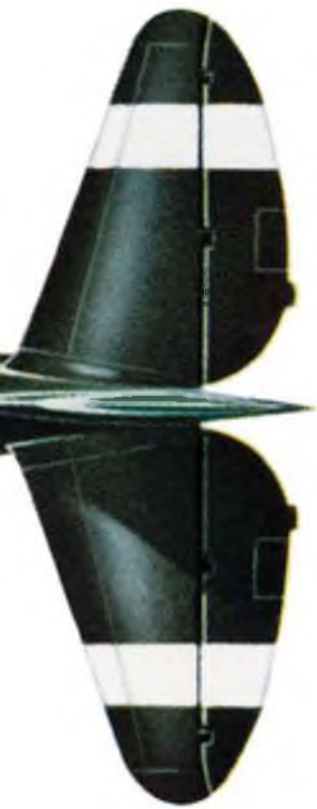
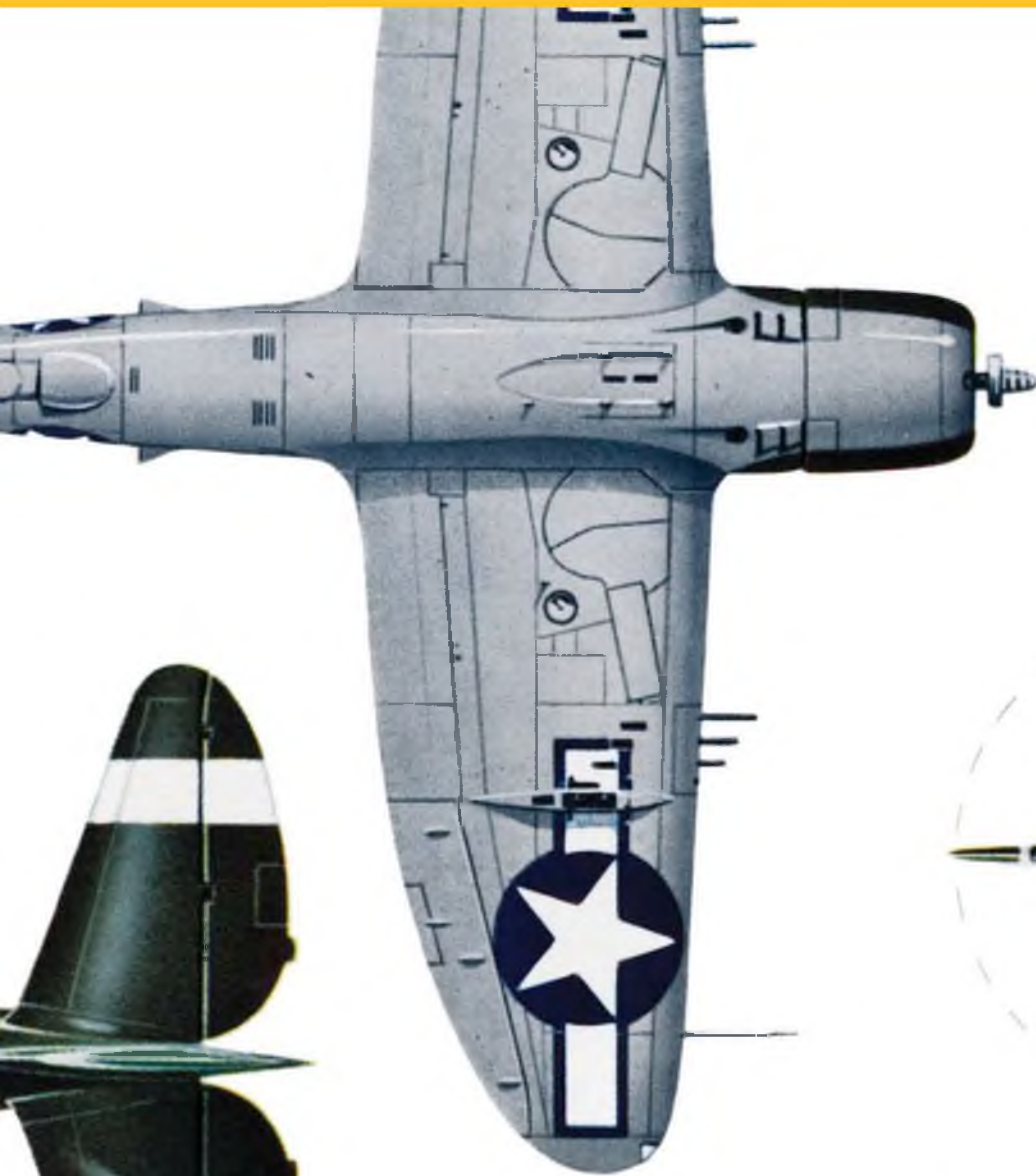

Zombie



P47-D FLYING COLOURS

Republic P-47D-11-RE Thunderbolt, S/No. 42-75510/HV-A, flown by Major Francis S. Gabreski (top 8th AF ace with 28 victories), commanding 61st FS, 56th FG, 1943. Olive Drab/Neutral Gray scheme with red front of cowlings and rudder; white bar on fin overpainted in a darker (fresh) green. Serial in yellow, code in white; spinner in white with red bands. 14 victories painted under the cockpit



P-47D-16-RE, S/No. 42-75836/32, 64th FS, 57th FG, 9th AF, Olive Drab/Neutral Gray scheme. Yellow bands around wings and vertical tail surfaces. Red spinner and front of cowlings, white code. National markings on fuselage sides, above port and below starboard wings. Pilot's name under cockpit reads CAPT P CARLL; note two kill markings ahead of cockpit

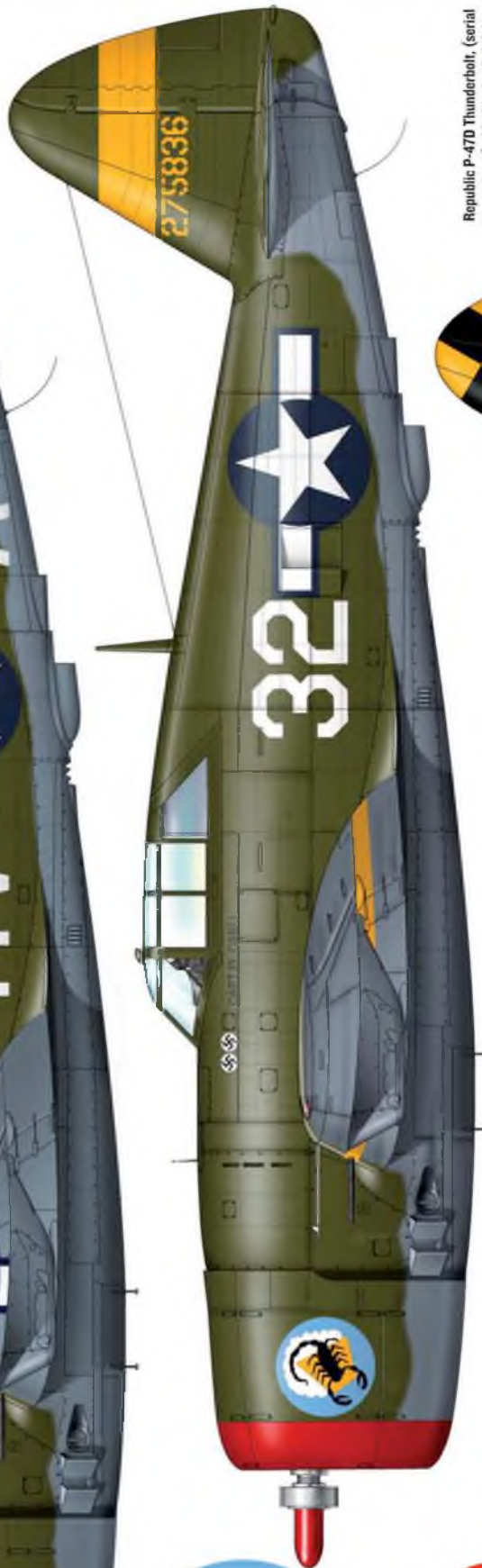

Republic P-47D Thunderbolt, (serial overpainted), 88, 'Big Stud', 319th FS, 325th FG, 15th AF, Foglia (Italy), 1944. Olive Drab/Neutral Gray scheme with red front of cowlings edged in yellow; yellow/black checks on fin/rudder and horizontal tail surfaces. Code '88' in white; name in yellow over playing card. Note six victory markings ahead of cockpit



PROFILES: 1/48 SCALE

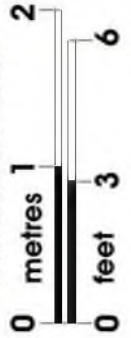

P-47D-15-RE Thunderbolt, S/No. 42-76363/LM-F, 62nd FG, 56th FG, 8th AF, Boxed, summer 1944. Ocean Grey and Dark Green camouflage applied on upper surfaces of the natural metal surfaces; Yellow rudder and Red front of cowlings. Codes in White while the serial is Yellow; Black/White stripes underneath rear fuselage only. National markings in six positions

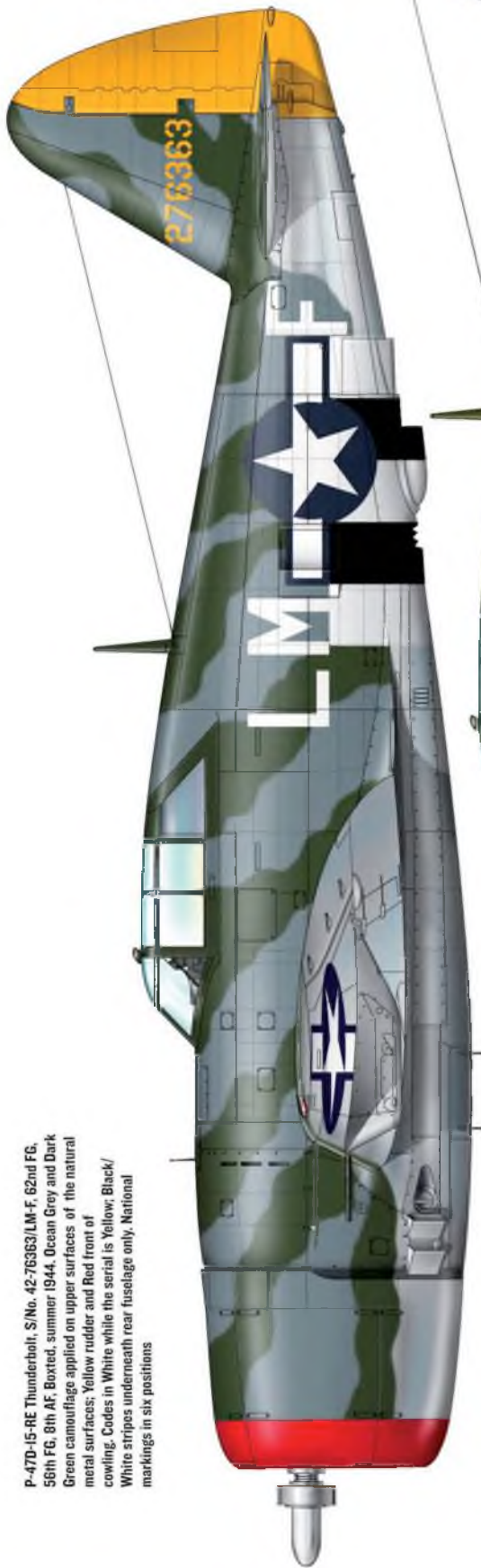

Republic P-47D-21-RA, S/No. 43-25429/C, 'Miss Mary Lou', 19th FS, 318th FG, 7th AF, Saipan, 1944. Olive Drab/Neutral Gray scheme with natural metal cowl areas and tail surfaces; bands around tail in mid-blue. Serial in black; code in white. Name on cowlings in mid-blue with yellow outline; note four victory markings below cockpit

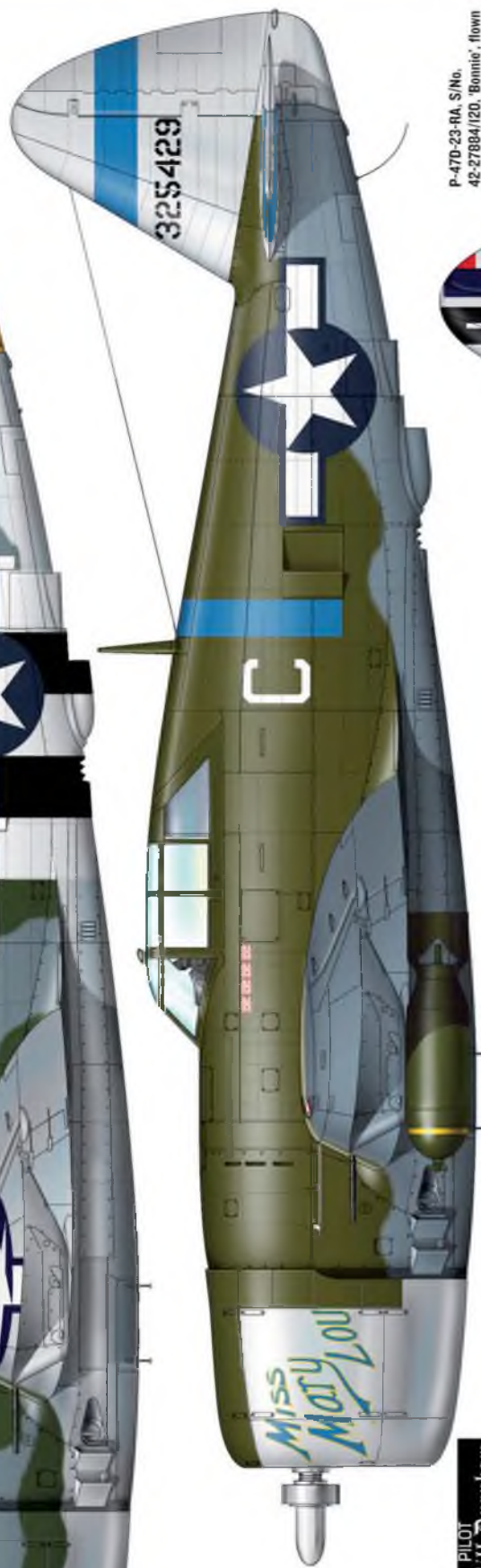

P-47D-23-RA, S/No. 42-27884/120, 'Bonnie', flown by Maj. Bill Durnham, 460th FS, 348th FG, Tacloban, Leyte, Philippines, 1945. Natural metal overall with black stripes around wings and rear fuselage; black vertical stripe with 120 in white on fin. Rudder in blue/white/red; 'Bonnie' in yellow, outlined black. Olive Drab anti-dazzle panel extended onto fuselage spine

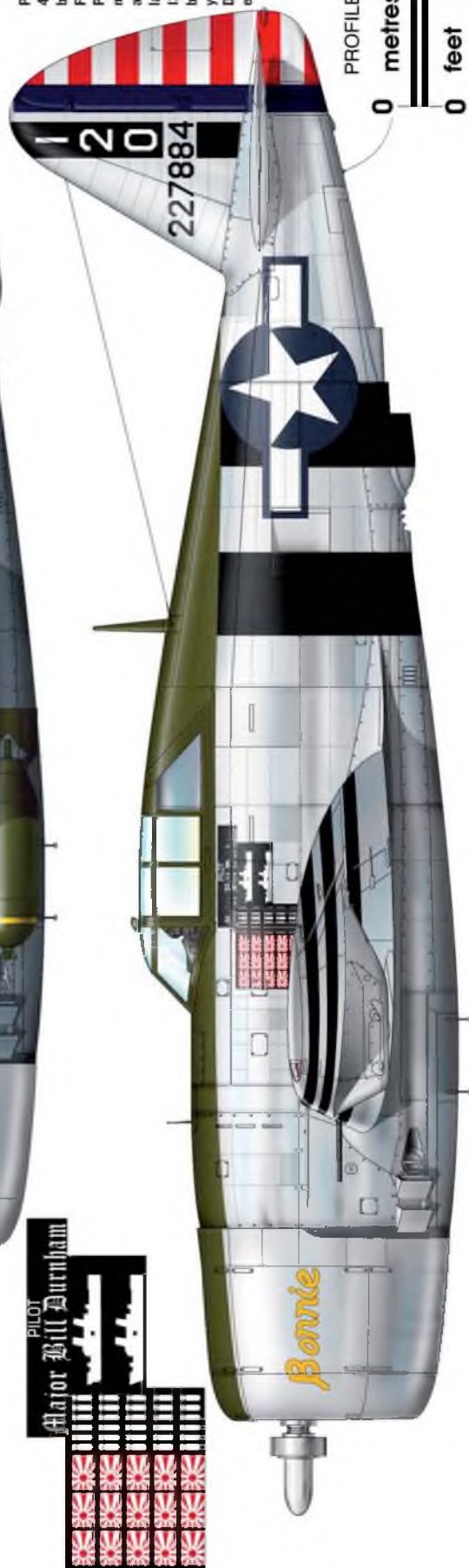

PROFILES: 1/48 SCALE

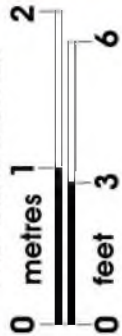

OVERALL - NM
NOSE LETTERING - B
OUTLINED IN WHITE
OVER RED NOSE BAND

P47D-21-RE
AS USED BY MAJOR ROBERT JOHNSON
FOR HIS LAST 8-10 MISSIONS
62 ND. SQUADRON, 56TH FIGHTER GROUP

NOTE
62 SQ
WERE
ROBE
STAD
15-2
MAS

27 CROSSES B OUTLINED W ONE MORE ADDED LATER

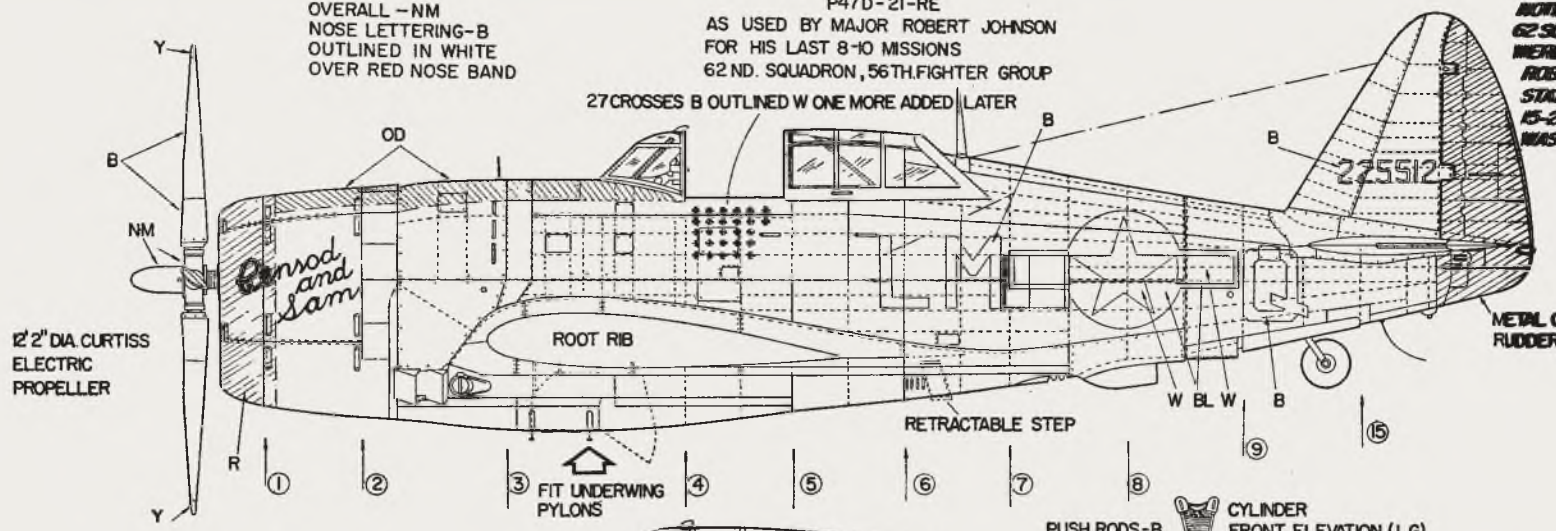

- COLOUR KEY**
- NG - NEUTRAL GREY
 - OD - OLIVE DRAB
 - B - BLACK
 - BL - BLUE
 - R - RED
 - CY - CHROME YELLOW
 - W - WHITE
 - GD - DARK GREEN
 - LG - LIGHT GREY
 - DSG - DARK SEA GREY
 - AB - AZURE BLUE
 - DB - DARK BLUE
 - NM - NATURAL METAL

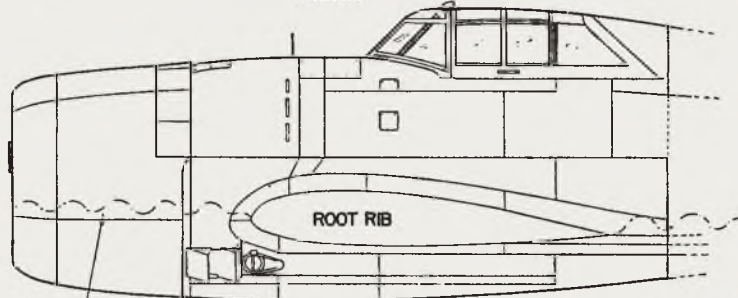

PUSH RODS - B
CYLINDER FRONT ELEVATION (LG)

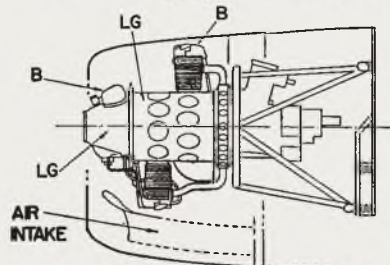

ENGINE DETAIL - P47D SERIES

P 47B NOSE DETAIL - REAR FUSELAGE AS P47D
FIT 12" 2" DIA. CURTISS ELECTRIC PROPELLER

NG BELOW (ALL UNDERSURFACES)
OD ABOVE (ALL UPPER SURFACES)

LM-Q INSIGNIA
PORT UPPER WING
ONLY

PITOT HEAD
PORT WING ONLY

GILL ARRANGEMENT
OF P47D-II-RE

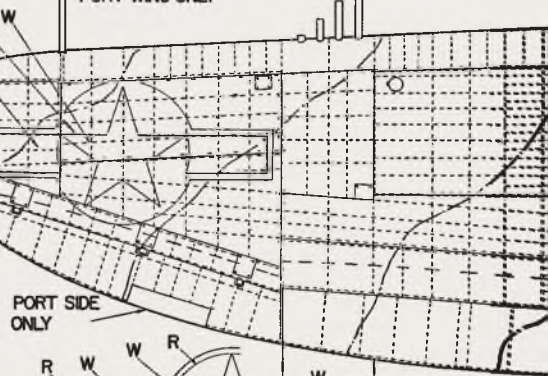
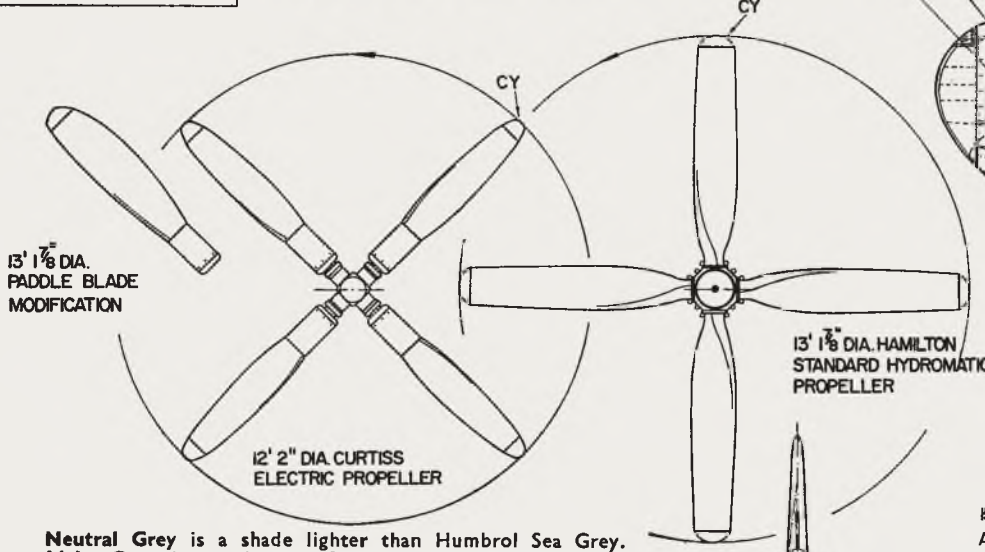

150 U.S. GALLS TANK
AND PYLON FROM
OUTBOARD

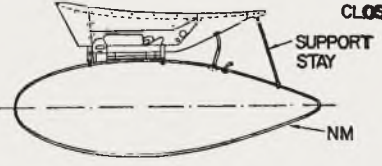

INTERCOOL
DOORS
CLOSED

Neutral Grey is a shade lighter than Humbrol Sea Grey.
Light Grey is a mixture of one part No. 30 Humbrol
Dark Green and two parts of Humbrol No. 31 Slate Grey.
Grateful acknowledgment is due to the assistance of
David Brazelton, who provided considerable research
material for the preparation of this drawing.

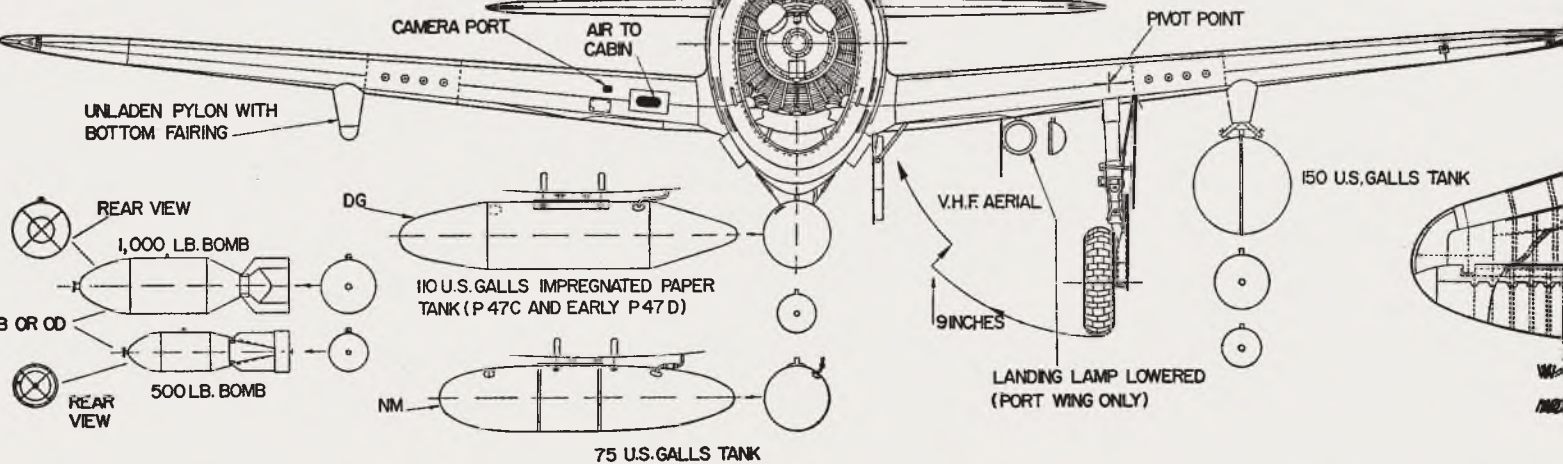

ALTHOUGH
ON RUDDERS
YELLOW,
BERT JOHNSON
ED BY LETTER
99 THAT HIS
RED.

P47D-22-RE

82nd SQUADRON 78th FIGHTER GROUP U.S.A.A.F.

CURTISS ELECTRIC
13' 1 7/8 PADDLE -BLADE
PROPELLER

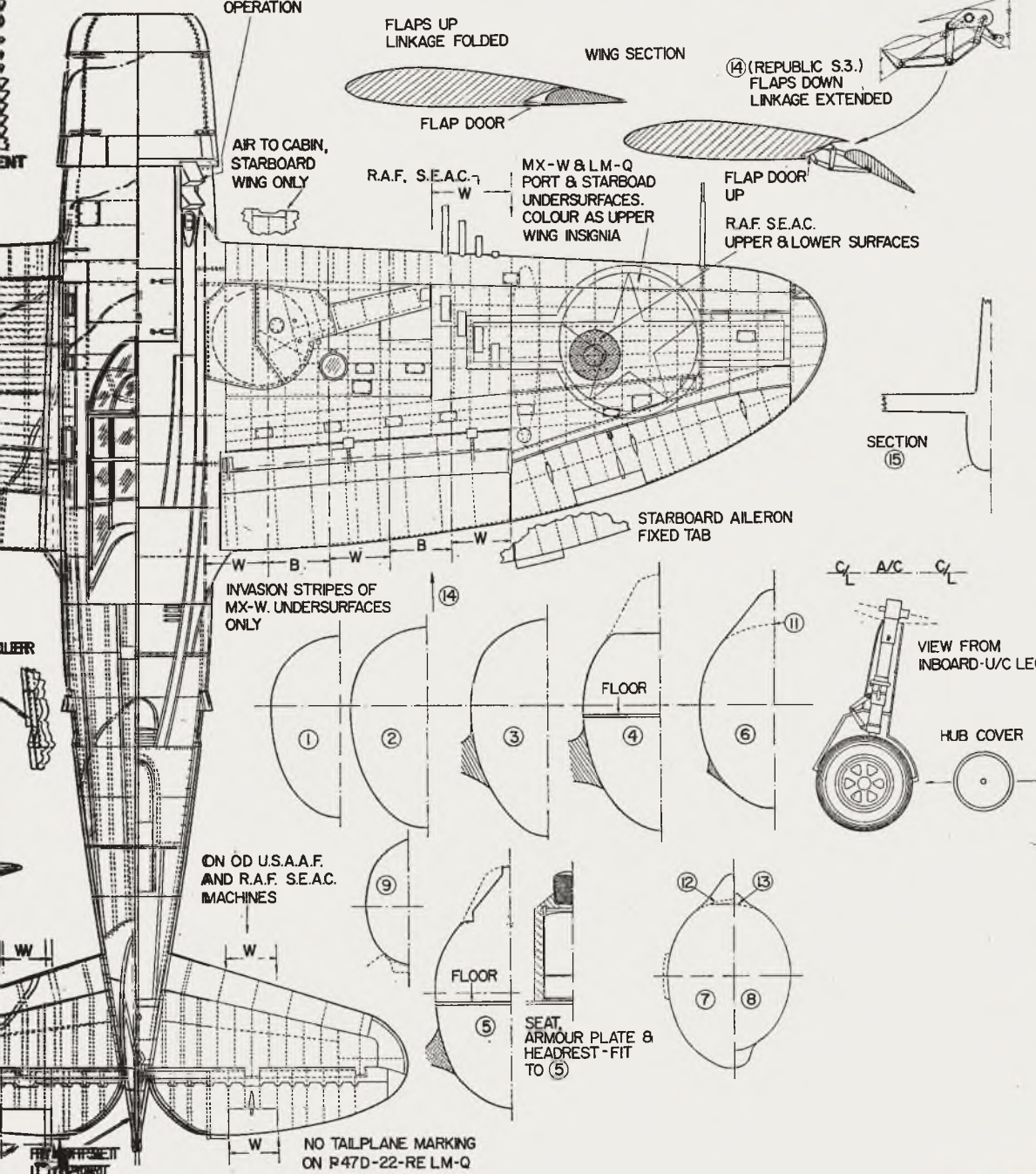
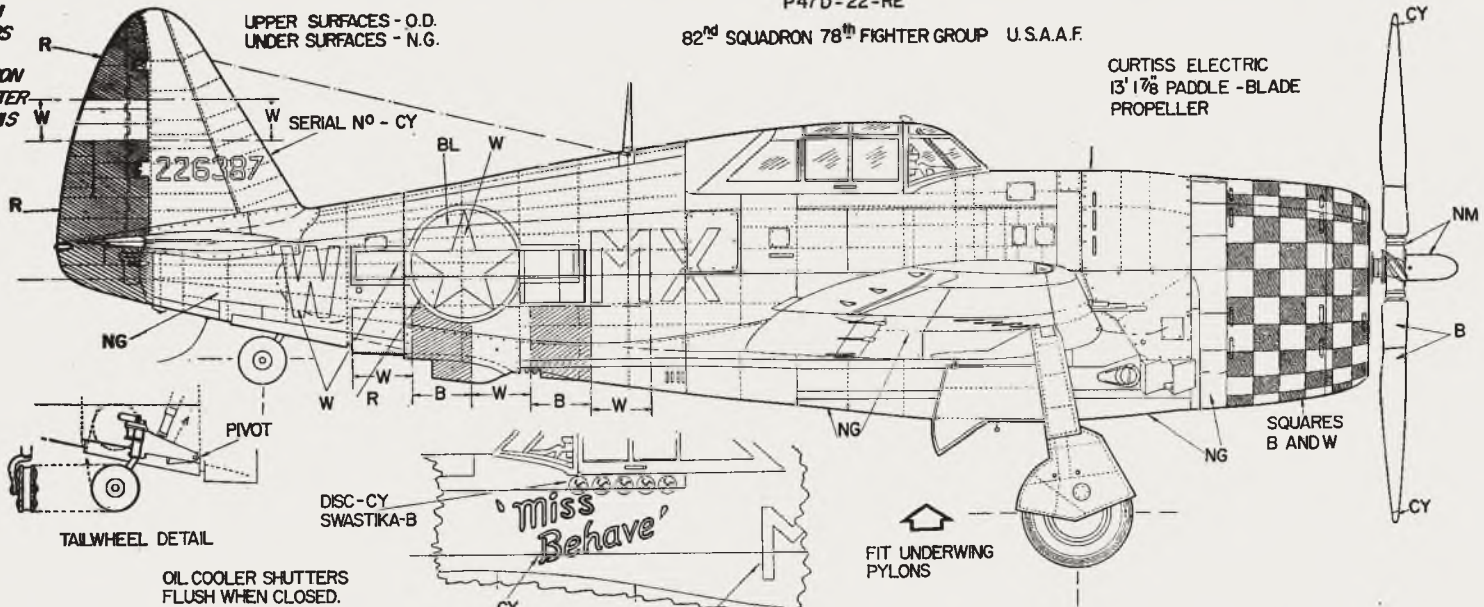

REPUBLIC P-47D THUNDERBOLT

MACHINES PRIOR TO P-47D-25 HAD FABRIC-COVERED
FRONTIER AND BELLEVATORS. MODIFICATION WAS MADE
TO METAL-COVERED SURFACES, AS SHOWN, IN THE
FIBER.

SCALE 1:40

RYAN PT-22

PART 2: Continuing the construction of an electric powered, 52" span sport scale model designed by Peter Rake and built by Pat Lynch.

Before getting too far into describing the fuselage construction I'll point out once more that Pat did in fact modify the rear end of his model slightly. To remind you of those changes, here's what I said in the opening part of this article last month.

As I said, this was only ever intended as a sport-scale model from the outset and the rear fuselage shape isn't 100% scale. Pat decided he would like to change that, so made new side keels and some modified formers. This does nothing to change the basic design, or affect the way in which the model flies, but it does

give any other potential builders food for thought should they wish to follow a similar path. I'll illustrate the alterations Pat made, so you can see how he approached it, but describe how the standard model is built. Construction remains basically the same, with only the shape of a few parts being different.

“ Before any actual building is done I strongly recommend that you read through this and do a dry run of the assembly ”



Despite not being as detailed as we're used to seeing from Pat his PT-22 is still a very attractive model.

EDITOR'S NOTE:

Due to the manner in which the three plan sheets of the Ryan PT-22 had to be laid out, the rear fuselage and the opposite wing panel comes in this issue (Part 2), part 1 (last issue - October 15) carried the front fuselage and one of the wings and the final sheet in Part 3 will include the tailplane, undercarriage etc.

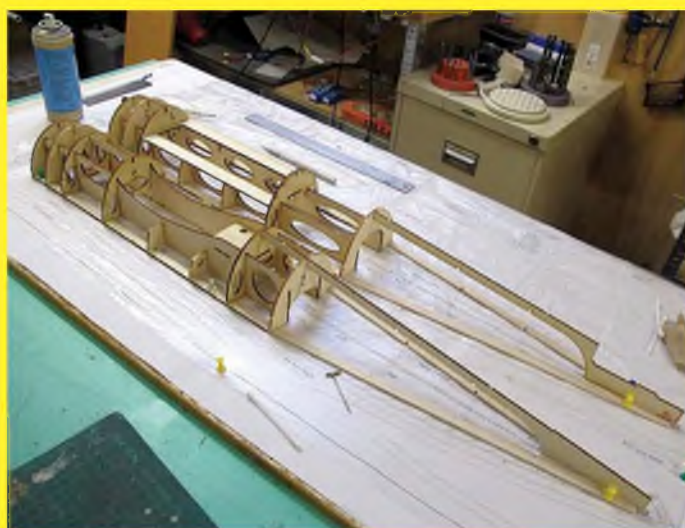
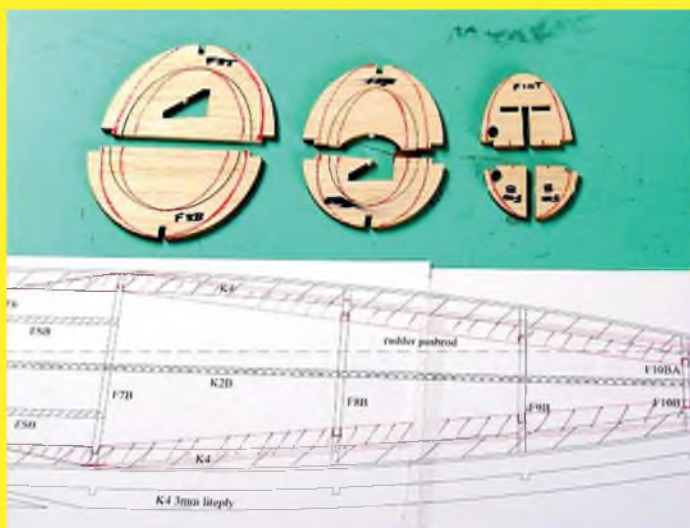

Here you see the slight changes Pat made to the tail end, and his revised formers.

The two sets of side keels pinned down and the front section's formers glued in place. I would have fitted the remaining formers before add the rear keel pieces.

What this means is that while the plan shows curved sides aft of the wing (viewed from above), Pat straightened them out a bit so his fuselage resembles a section of cone. The choice is entirely yours, as to which route you take and it doesn't involve too much extra effort to make the changes.

THE FUSELAGE

The fuselage is built as two distinct 'shell' type units (upper and lower), which are then joined to make a complete fuselage. The advantages of this style of construction on round fuselage types include the ability to sheet (or plank) the shells while these are still firmly secured to a flat surface.

Because all crosswise components are built into the individual shells (whereas a vertical split means the halves need to be joined before such items can be fitted), it also means that access hatches may be built and sheeted at the same time. As an added bonus, much of the radio installation can be completed before everything is enclosed in a fully sheeted fuselage.

Of course, you can join the unsheeted shells and then add your planking or sheet balsa but there is always the risk of twisting the shells while doing it this way.

CONSTRUCTION

Before any actual building is done I strongly recommend that you read through this and do a dry run of the assembly. It isn't complicated, but does require that things are done in a certain order if it is all to key together correctly. It may just help you avoid having bits left over after you have the basic shells built and all glued up - bits that there would

then be no way to fit into their slots and notches.

Begin building the fuselage by pinning down the side keel parts over their individual plan views. As you'll see, the forward parts are numbered T or B according to their use, but the rear parts for both upper and lower shells are the same. I know it isn't rocket science to work that out, but now if you get it wrong it's entirely your own fault, not mine.

Now position parts FST and FSB over the drawings and glue in place parts F1 (T and B) and F7 (T and B) to hold them securely in place. Make sure that you have already laminated parts WB and WBA (complete with securely glued in place blind nuts) and secure them into parts FSB while you still can. Assemble parts F3T, X and F5T and glue the assembly into place on the side keels and FST. Similarly, assemble BT, F3B and F6B and glue them into the lower fuselage shell. It's important that you do it this way or you'll have trouble fitting X and BT at a later stage.

With the basic 'core' of both shells assembled, the remaining formers and keels can be glued in place and the tail seat (TS) glued in place. The hardwood strut blocks should be drilled, shaped to follow the contour of the fuselage formers and firmly attached to X. The assemblies should be allowed to dry thoroughly before continuing.

Please note, when fitting the F1 formers, that there is a right and a wrong way to fit them. The hole with which the motor plate M will align is not central in the formers, but offset to allow the mount to be in the correct position to accommodate the side thrust. So, make sure you get them both (upper and lower) the right way

round. A simple way of ensuring this is to align them with the drawing, which shows them viewed from the front, and mark that face of each F1.

THE HATCH

To ensure a snug fitting access hatch I would suggest building that directly onto the upper fuselage while said fuselage is still pinned down.

Tack glue part AH3 in place and carefully ensure that it is shaped to allow the sheet covering to follow the line of the sheeting over the main assembly. Glue in the hatch formers so that the parts AH1 fit closely against F3T and F5T, but taking care to ensure they aren't glued TO those formers.

Sheet the hatch while it is in place to ensure that you don't inadvertently disturb the line of the end formers.

SHEETING

Before fitting the sheeting, there are also some choices available to you; it all depends on how smoothly you can blend sheeting into block balsa sections, and how much support you want beneath the sheet in certain areas.

Whilst there isn't much choice as far as the upper block tail fairing goes, which has to be fitted after the tailplane is in place and the fin in position (unless you can fit them before and ensure they stay where they're supposed to be), but the lower block sections do give us a choice.

As you will note, there are sections of laminated parts (WS) around the wing position and a piece of block balsa below the extreme tail. If you are confident that you can make neat, secure butt joints where the sheet meets them, then it's fine to fit these after the sheeting is in place.



As you see, Pat chose to trim the wing seat parts flush with the formers and sheet over them.



Because of the simpler shape, Pat was able to use pre-curved pieces of sheet to skin his fuselage.



The fatter tail end is also part on the modifications Pat made. Here you see the template he made for shaping the tail blocks in situ.



Note how Pat masked his motor while sanding the nose block to final shape.

However, if in any doubt about that, and bearing in mind that the wing seat area is likely to receive quite a bit of handling wear, you may well be advised to fit the block/laminated parts, shape them to follow the required line flush with the formers and sheet or plank the entire lower fuselage shell, over the top of those areas.

It makes absolutely no difference to the weight because you'll be removing as much wood as you then add back with the sheeting, but will result in a much smoother finish without having to worry about sheet to block joints causing weak spots, or difficult to sand areas. As I say, it's all a matter of personal preference, but does result in a slightly more durable arrangement, and you'll be finish-sanding wood that is all very similar in consistency.

So, with that all explained, and my reasoning expanded upon, it's time to do the actual sheeting. Personally, I prefer to sheet these items with them secured to a firm base, but they can also be sheeted after removal from the board. If you are sheeting them while pinned down, please take care not to enclose pins that really should have been removed while you could still get to them!

Either way, you have yet another

decision to make. You can either cover the fuselage in 1/16" sheet balsa, or plank it using strips of 3/32" (or even 1/8") balsa and sand back to 1/16" thick. If you make the same modifications as Pat did, that slightly simplifies the sheeting option because it removes some of the compound curves involved with the 'as drawn' fuselage. If taking the planked route, don't be too concerned about precise final thickness towards the tail. With the relatively long nose of this model, combined with the sweep of the wings, you are unlikely to end up with a tail heavy model.

Apply the covering of your choice, mating it snugly to the side keels, and either around or over any block areas (refer to what I said earlier) and allow to dry completely. Although you could do some sanding now, it's best done after the two shells are joined and any seam filling required completed.

FUSELAGE SHELL ASSEMBLY

With two separate fuselage shells more or less complete, it's time to start turning them into a complete fuselage. Before anything is actually glued together however, (you just knew there was going to be a 'however'), there are jobs that

need doing to the individual shells.

To start with, those strut holes in the hardwood blocks need to be opened up through the outer skin. Don't fit the tubes yet though, brass being somewhat harder to sand than balsa. If, instead of pushrods, you prefer to use 'snakes', now would be a good time to cut their exit slots and install them. Make sure that where they exit the fuselage they are trimmed level with, but recessed back from the outer surface.

Once again, they're harder than balsa and will complicate sanding smooth if they get in the way. At least at this stage it's a simple job to get a really secure fixing inside the tail end, and make sure they're secured along their length. Although servos could be installed at this stage there's no real advantage because only one 'snake' can be hooked up before the shells are joined.

Now you can finally join those two fuselage shells. If you got it right there should be very little, if any filling to do along the join line and you can set about sanding everything smooth. It's not a bad idea if the under wing block and hatch are spot glued in place during this process. Then there's a more than fair chance they'll actually match the rest of



After being re-motored and refurbished the model sweeps by in a low pass for the camera. Initially it was somewhat faster than Pat is used to.

the fuselage once they've been removed.

Taper the motor plate (M) for side thrust and glue that to the joined F1 parts - remembering what was said about the hole in the centre of M aligning with the offset hole in parts F1T and F1B. Roughly hollow out some nose block pieces (so they fit around M) and spot glue them to the nose. Since precise nose length isn't that vital, use your particular motor to set up the position of N, and the angle required on the nose blocks.

After considerably more shaping and sanding, your nose blocks should bend nicely with the sheeting at their rear and N at the front. Cut through N as indicated, remove the nose blocks and hollow them out to clear the motor. The lower block can be glued permanently back in place, but the upper block will form a motor access hatch.

If you prefer to get the tail blocks in place before covering, use some scrap spacers to provide tailplane and fin slots, glue the blocks securely in place and trim and sand to shape.

Cut the cockpit openings, make up the block balsa headrest and you should be looking at a more or less completed fuselage. Next time we'll see about getting the tail surfaces build, the model assembled and the all important flying. ■



With the elastic cord rigging gaining access for battery changes is a totally painless affair.

CUT PARTS
SET FOR THE

RYAN PT-22

Get straight down to construction without delay! This month's full size free plan feature is supported by a laser-cut set of ready-to-use balsa and plywood components. This provides all the parts that, otherwise, you would need to trace out onto the wood before cutting out.

IT DOES NOT INCLUDE STRIP AND SHEET MATERIAL OR SHAPED WIRE PARTS

Price £75.00

plus carriage: £11.50 (UK); Europe £26.00

Order set CUT/FSM510

Shipping Note: For shipping to destinations outside the UK and Europe, you will be charged our standard flat-rate price of £49. This covers most destinations and secures your order with us. However, we will contact you accordingly with an accurate total shipping charge prior to dispatch and either issue a refund or a PayPal money request for the balance.

Visit our secure website:

www.flyingscalemodels.com

to order yours



Order direct from:- ADH Publishing, Doolittle Mill, Doolittle Lane, Totternhoe, Bedfordshire, LU6 1QX, UK. Tel: 01525 222573/
enquiries@adhpublishing.com.

RYAN PT-22 FLYING COLOURS

RYAN PT-22, 1-342
(KINNER R-540-1) AS
AT MATHER FIELD,
CALIFORNIA, ON
9TH MAY, 1942.

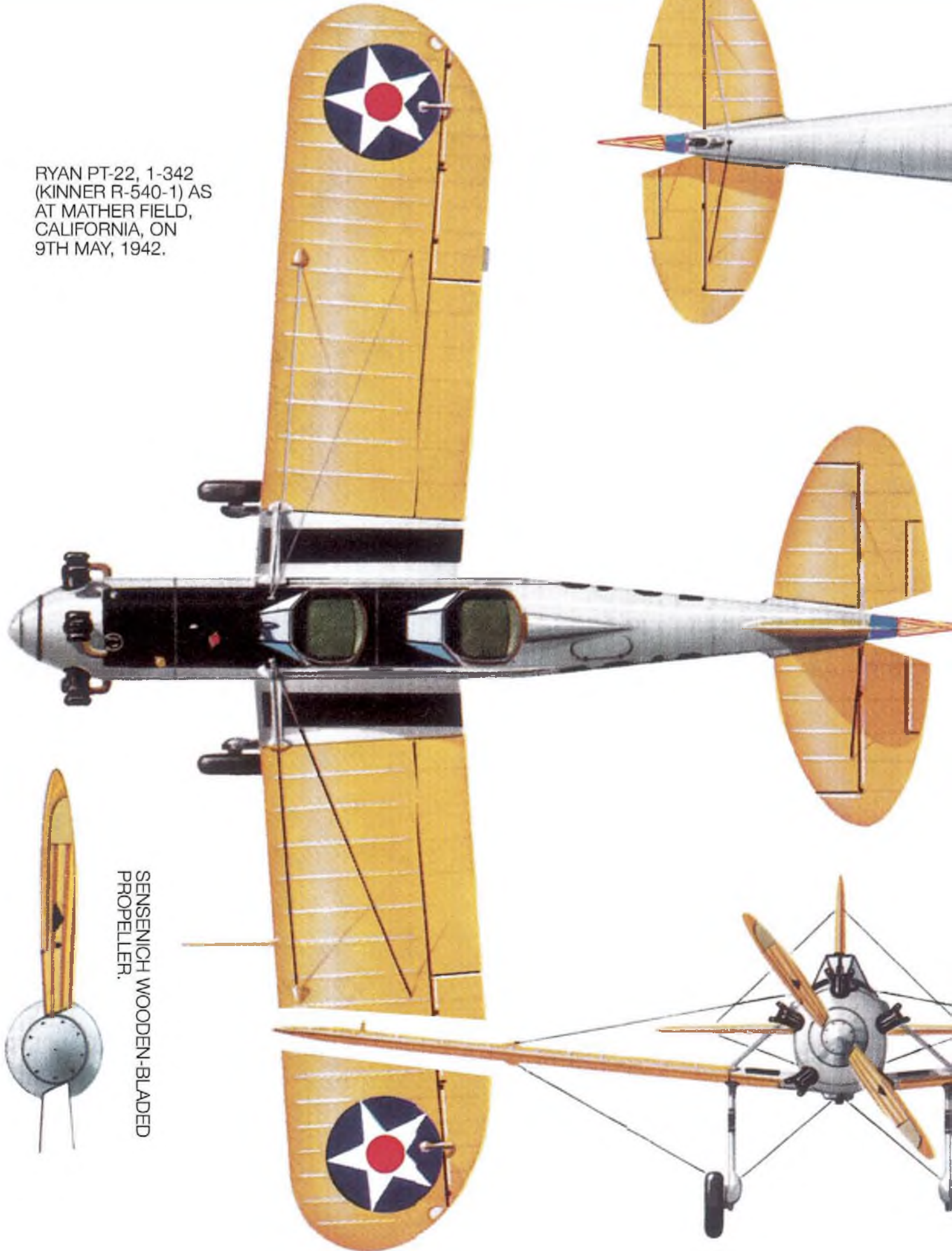

SENSENICH WOODEN-BLADED
PROPELLER.

RYAN PT-22

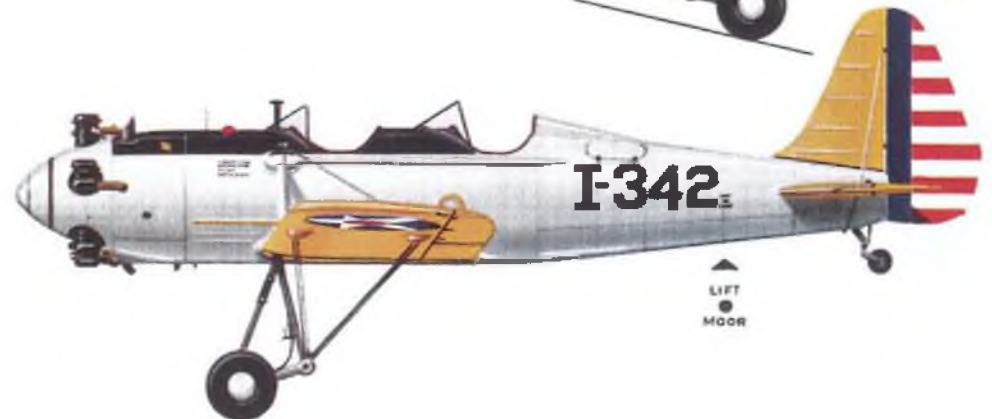
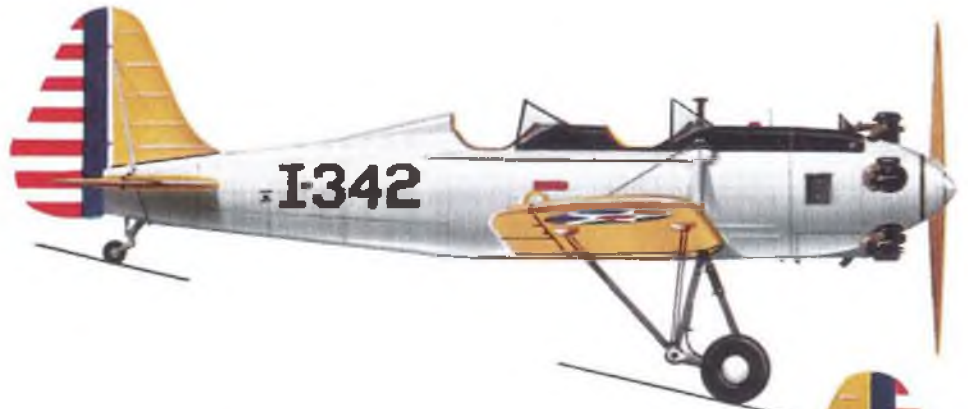
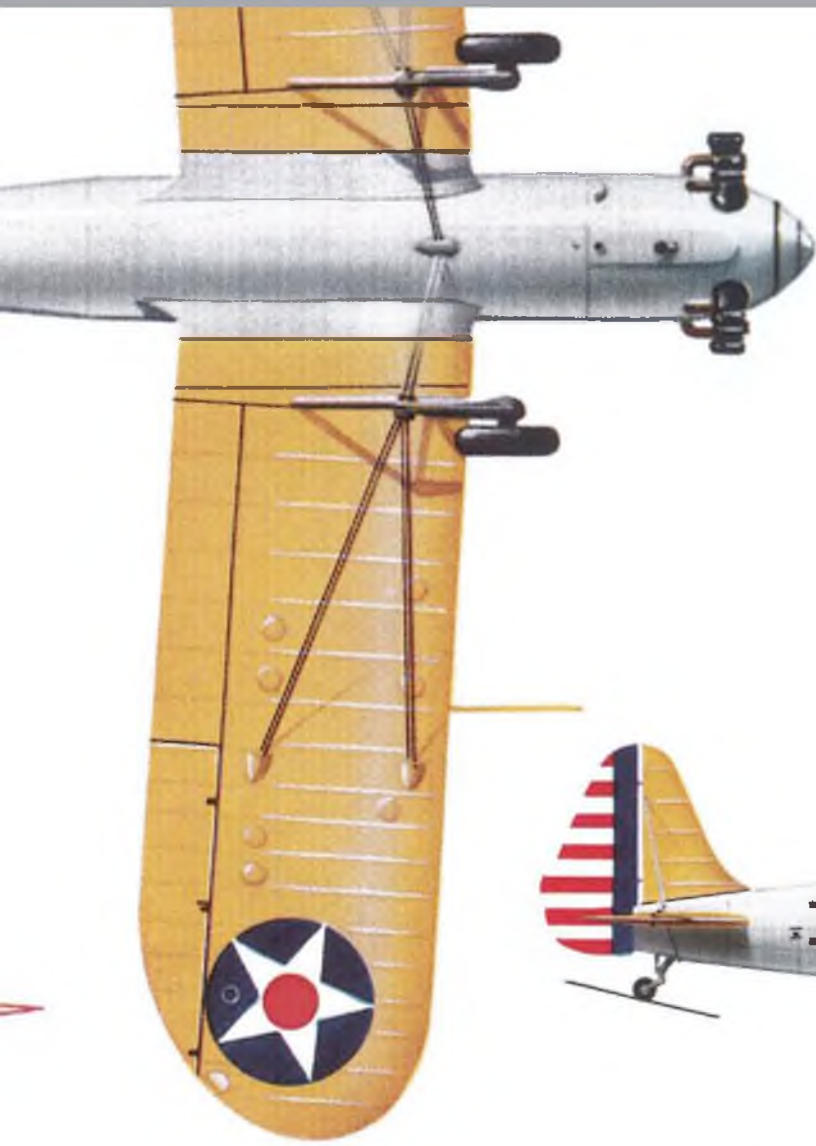

UNDERCARRIAGE JACKING POINT, INSIDE SURFACES.

FIRE EXTINGUISHER LOCATED INSIDE



RYAN PT-22

CLOSE-UP PHOTO STUDY FOR THOSE WHO LIKE TO PILE ON THE DETAIL



1 & 2: Two views of the front fuselage section and cockpit, showing the windscreen, instrument panel, bracing strut and bracing wires with adjustable clevises. 3: View of the two open cockpits showing both windscreens and the cockpit coamings. 4: Rear cockpit instrument panel. 5: Control column and rudder pedals in the rear cockpit. Front cockpit similar. 6: Throttle quadrant on the left side of the rear cockpit. 7: Rear cockpit coaming and headrest.



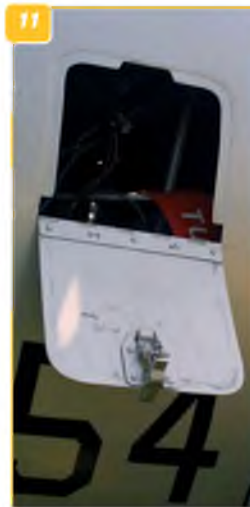
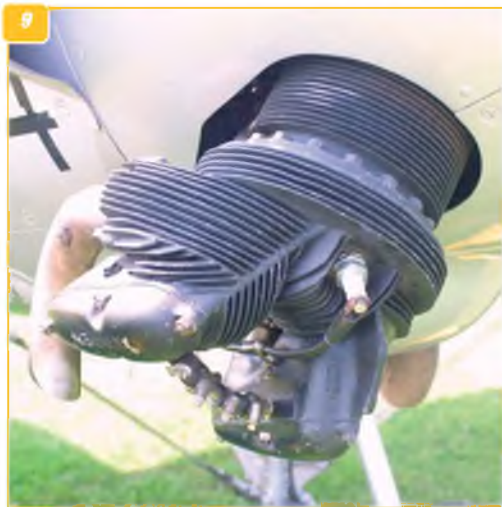

8: Right side of engine cowling showing air intake scoop and engine cylinders. 9: Close up of engine cylinder head (lower right pot). 10: Further detail of the front fuselage and engine cowling showing the wing brace strut and streamlined bracing wires. 11: Close-up detail of access panel on the left side of the engine cowling just behind the engine. 12: The engine cowling left side showing the access panel position and oil filler cap.



13: The fin and rudder, showing the hinging and the gap between the two vertical surfaces. 14: The tailplane and elevator are similarly hinged and widely separated. 15: Detail of an elevator hinge and anchor point for the bracing wire between the tailplane and the fin. 16: Close-up of the top surface hinge-line of the left side elevator trim tab.

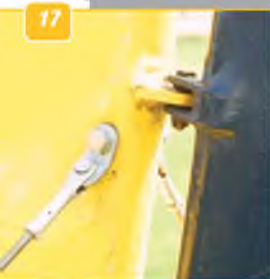

17: Rudder hinge and anchor point for bracing wire. **18:** Underside of elevator, showing linkage to trim tab. **19:** Tailplane junction with fuselage, showing the metal fairing. **20:** The castoring tailwheel unit. **21:** Detail of the top of the engine cowl, left side, showing the oil filler cap and top engine cylinder. **22:** The fairing on the left fuselage side that covers the wing brace strut anchor point. Also, the anchor point for the bracing wire clevises. Right side similar. **23:** Fuselage side detail, showing the pressed metal strake that runs along the side under the two cockpits.



24: Rear fuselage top decking, showing the access panel.



25: View underneath the tailplane, showing the bracing wire anchor points on the fuselage and tailplane trailing edge.



27: The fairing behind the rear cockpit headrest.



28: Close-up of the tailplane undersurface bracing wire anchor point on the fuselage bottom.



29: Rear fuselage at the tail post, showing the elevator joiner and the flexible control link to the elevator trim tab.



30: Open hatch to the baggage hold behind the rear cockpit, left hand side.





32-38: The main undercarriage in detail - likely to be a major undertaking in the construction of a model of the PT-22. The mechanism features a shock-absorbing arrangement designed to withstand the punishment inevitable when trainee pilots practise landings! With it 'hanging out', damage could be easily detected and parts quickly replaced.



39: The main undercarriage rear anchor point under the wing. **40:** Front main undercarriage anchor point on wing underside. **41 & 42:** Centre-line bubble fairing on fuselage bottom where the main undercarriage bracing wires attach to the fuselage. **43:** Pressed metal fairings and access panels on wing underside. **44:** The wing root, right hand side, showing rubber panel seals, the cockpit access tread panel and the main bracing strut. **45:** Detail of the pressed metal bubble fairing that covers the wing brace anchor point. **46:** The cockpit access tread panel on the right hand wing panel. Left side similar. **47:** The pitot head on the left wing panel. **48:** The right wing, showing the aileron and flap.



www.flyingsca



NEVER MISS AN ISSUE
SUBSCRIBE TODAY!

www.adhpublishing.com

£42

Get your copy delivered to your doorstep before it reaches the newsagents by subscribing



www.adhpublishing.com



01525 222573



enquiries@adhpublishing.com



JOIN THE ELECTRONIC REVOLUTION

Enjoy FSM on your iPhone, iPad, Android phone or tablet PC.

Visit the App Store or Google Play and search for "Flying Scale Models" or visit PocketMags.com to purchase single issues and subscriptions to read on your device or PC.



Available on the iPhone
App Store



Google play

lemodels.com

Follow us on Facebook
facebook.com/pages/Flying-
Scale-Models/495012097186048

Follow us on Twitter
@ScaleModelFlyer



- MASTER MODELS
- TYPE HISTORY
- IN DETAIL
- SCALE DRAWINGS
- FREE PLANS
- CONSTRUCTION
- TECHNIQUE
- SHOW REPORTS
- FLYING COLOURS
- HOW TO'S
- GLIDERS
- ELECTRIC
- SCALE INDOOR
- SCALE REVIEWS
- SCRATCH BUILD

ALSO
AVAILABLE
FROM ADH
PUBLISHING...

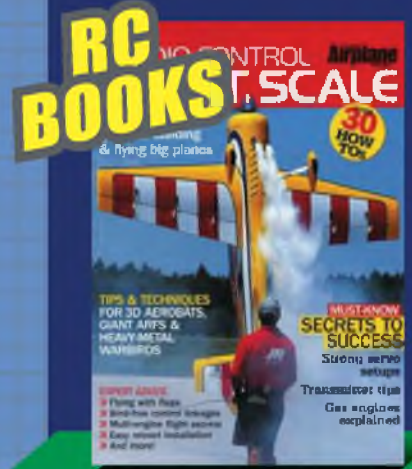

www.adhpublishing.com/shop



SUBSCRIBE FOR ONLY **£44**



SUBSCRIBE FOR ONLY **£55**

SEE THE ADH
WEBSITE FOR MORE...



SCALE FROM SCRATCH

WANT TO TAKE A STEP BEYOND KITS AND ARTFS? KEN SHEPPARD CONTINUES HIS SERIES TO ENCOURAGE OWN-DESIGN SCALE MODELS

PART 9: PULLING IT ALL TOGETHER

Last month saw the airframe structure completed, the wing-to-fuselage fairings added and the whole lot covered in lightweight glasscloth, applied using acrylic varnish. After the airframe has been lightly rubbed down, the paint finish can now be applied. But first I decided to make the moulds for the vac-formed canopies and air intakes.

Canopies

Some people swear that a solid piece of hardwood is the best material to use when carving the mould blank for a canopy - it's also hard work, I would think. I use laminations of balsa, sanded and sealed - an initial mould may show signs of the laminations, but the trick, to avoid this, is to mould another plastic sheet over the

top of the first one - that virtually guarantees a smooth, distortion-free canopy.

My good friend, Graham Iredale, told me that - in fact he moulded the canopies from the moulds that I sent him - and he sent both first and second mouldings back to me - the first shows very slight lamination lines, the second is perfect.

The stages of balsa mould making are as follows. **Photo 1** shows the first few laminations being fitted - make sure they're oversize! **Photo 2** shows the mould ready for carving - its tack-glued in place. **Photo 3** shows the mould fully sanded, filled and sealed.

Before the mould can be made, however, additional balsa wedges have to be fitted around the periphery of the

mould to allow the plastic to fully pull down over the mould. **Photo 4** shows where Graham has added 'run-out' wedges to the mould, ready for vac-forming. The completed moulded sheet is shown in **Photo 5**. This is, in fact, the first vac-form and it was subsequently trimmed around the edge and a second moulding done for the final glazing.

The two identical fuselage-mounted air intakes were managed slightly differently. A master was carved from balsa laminations, split down the centre line to form two 'handed' halves and an extra lamination was glued and shaped onto the bottom of the 'split line'. This extra thickness allows a deliberate 'trim' line to show through the white ABS mould - the two halves are joined with strips of off-cut plastic and thin cyano, then any gaps





1: The first few laminations of the cockpit canopy mould blank. **2:** The mould, ready for carving. **3:** The mould fully sanded, filled and sealed. **4:** 'Run-out' wedges added to the mould, ready for vac-forming. **5:** The first vac-form, subsequently trimmed around the edge and a second moulding done for the final glazing. **6:** One of the completed intakes fitted to the fuselage, ready for painting. **7:** The three stages of carving from balsa sheet (medium hard). **8:** Before the exhaust stacks were finally fitted, the fuselage was painted and a fine thinned black enamel exhaust 'stain' added to the fuselage sides. **9:** The completed exhaust.

filled with 'Plastic Padding' easy sand filler. **Photo 6** shows one of the completed intakes fitted to the fuselage, ready for painting.

Exhaust stacks

With twin 12-cylinder engines in the full-size, there needs to be four identical exhaust stacks protruding out of the fuselage sides. I had built balsa lined rebates in the appropriate locations to give the impression of skin aperture edges - now we need to produce four stacks.

I initially thought of moulding these too, from a single master, but having carved the first, I figured it would be quicker to carve the other three as well. **Photo 7** shows the three stages of carving from balsa sheet (medium hard).

The initial outline was cut with a scrolling saw; the final shaping was effected by a fine round file and a piece of fine grade wet and dry paper. These were then sealed with dope, sanded down between coats - and then painted with enamels -

several colours, black, brown and grey painted whilst wet to give the impression of heat-stained metal. Before the exhaust stacks are finally fitted, the fuselage was painted and a fine thinned black enamel exhaust 'stain' added to the fuselage sides - as shown in **Photo 8**.

The completed exhaust is shown in **Photo 9**.

Camouflage colours/markings

The colour scheme applied to the top of the airframe (see heading picture) was hand-brushed, using *Tamiya* acrylic paints, using the Mk.1 eyeball approach to paint straight colour demarcation lines. If you're not confident to do this, then masking tape can be used before the second (darker) colour is applied. The *Tamiya* paint applied straight from the little bottle gives good coverage, with a single coat sufficient.

It took five little bottles of each to complete the top surfaces and a bit for touching up. But first, for the lower

surfaces, I opted for car aerosol acrylic paint. The blue colour is a bit too bright (*Ford Nordic Blue*), but it is nearly there - and so easy to apply on top of an all-over coat of flat grey primer (another car aerosol). Masking is needed for the blue/green demarcation lines - they need to be ruler straight and also mask along the wing and tail leading edges for a nice crisp line. The beauty with water-based acrylic is that it dries so quickly - you are soon ready to add panel lines and national markings.

Bearing in mind the 'sport-scale' finish of the model, I opted to mark the panel lines using a fine-tipped permanent marking pen, a steel 18" ruler and a strip of 1/16" straight edged ply, for bending round the curvatures (**Photo 10**). I did the wings first, using the panel line pattern from the *Tamiya* plastic kit diagram as a rough guide, checking that the position of the lines are the same port and starboard; simple, but I think it looks quite effective. The fuselage is a little more difficult due to

10



11



12



the curves, but take it steady, hold the ply straight edge firmly so that it doesn't slip and all should go well - again it looks quite tidy!

The canopy frame is simply painted on, using automotive lining tape as masking - its quite time-consuming applying all the strips of tape and cutting away all the overlaps (**Photo 11**), again ensuring port/starboard symmetry before painting (**Photo 12**) with a fine brush (two coats allowed to dry to build up an 'edge'), but the overall effect is well worth it - see **Photo 13**.

The good thing about modelling WW2 Luftwaffe aircraft is that the markings are all straight lines, meaning they're easy, if a bit slow, to mask up. **Photo 14** shows a wing underside cross all masked up (plus an unintended mistake) before painting the black cross and semi outline, with **Photo 15** showing the cross before application of the white in-fill (brushed without masking - any errors can be touched up!).

For the tail swastika, I photocopied the example in Gordon Whitehead's book 'Radio Control Scale Models for Everyday

10: Panel lines, marked out using a fine-tipped permanent marking pen, a steel 18" ruler and a strip of 1/16" straight edged ply, for bending round the airframe curvatures.

11: The canopy frame is simply painted on, using automotive lining tape as masking - its quite time-consuming applying all the strips of tape and cutting away all the overlaps.

12: Ensuring port/starboard symmetry before painting.

13: A fine brush is used to apply two coats allowed to dry to build up an 'edge', but the overall effect is well worth it.

13



Flying' (every type of Axis markings are given, with size ratios - invaluable!) and scanned the image onto white decal paper, cut round the black, leaving an appropriate white edge. I allowed the ink to fully dry and then water-slid them onto position.

Undercarriage Doors

Last month I proposed a scheme for fitting both external and internal undercarriage doors to the main legs - forget it! After a whole afternoon trying to sort out the geometry, I gave up trying to fit the fuselage-mounted doors. As a result only the main legs have doors fitted (**Photo 16**). Since then, I have seen a brilliant solution by my club mate Tim, who uses string and an over centre spring - so I might retro fit using that idea at a later date (if the model survives!).

Radio fit

I used all seven channels on my Futaba Rx and, following a report from a guy who had built a Do335 several years before, I fitted a GWS Gyro on the elevator, set at full gain, as his model porpoised in pitch quite severely. **Photo 17** shows how it all fitted in, with the gyro adjacent to the receiver and a separate mini servo operating the steerable nosewheel, via a Y-lead to the rudder servo. On the top of the nose, under a hatch (**Photo 18**), is access to the I.C. fuel tank, the EP flight pack - 10 x 3300mAh NiMH (this was before the day of the Lipo!), radio on/off switch and Rx battery (6v) charging lead. The hatch is retained by a front and rear sliding pin.

The RCV 58CD fits perfectly into the very small diameter cowl and a front blanking plate ensures that all the air going into the cowl goes through the head fins -

Photo 19.

Engine management

Suddenly, the model was finished! On the bench everything worked, so it was time to try out the engine management system. I wanted to be able to run both the I.C. and EP motors from the one stick and so decided that it would be logical to start the I.C. motor first, warm it up and set the tick-over, then increase the revs by opening the throttle two or three clicks above tick-over - and plug in the EP flight pack. The ESC would recognize the above tick-over setting as the cut-off point and after a couple of seconds the esc would give the audible warning that the motor was armed - pushing the stick forward would now wind up the revs on both motors.

Shutting the throttle would mean that the rear motor would stop before the I.C.

motor reached tick-over speed. Should either motor cut, I would still have the other producing thrust. In the event of a full flight, the power from the EP motor would start to decline, giving me warning that it was time to land. In the air, timing the EP motor run would give me an idea of the safe flight margin.

At least, that was the theory!

I ran both motors independently to check that everything was OK, then went



The RCV 58CD fits perfectly into the very small diameter cowl and a front blanking plate ensures that all the air going into the cowl goes through the head fins.

through the start-up procedure detailed above - and it worked! The combined throb of the four-stroke and the whine of the Twister 19 is a unique sound and the combined thrust was very re-assuring. Vibration was nothing unusual and a range check from tick-over to full bore produced no noticeable jitters or servo ticking - all my excuses had run out! ■

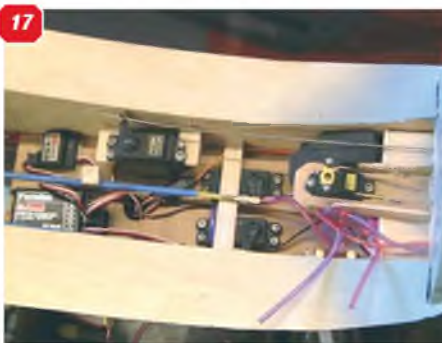
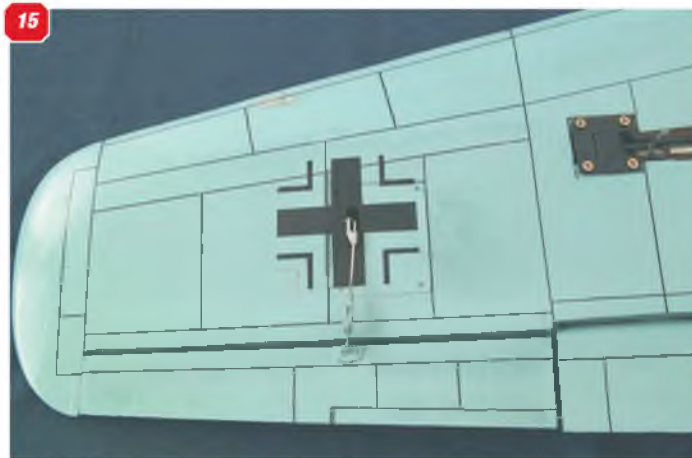
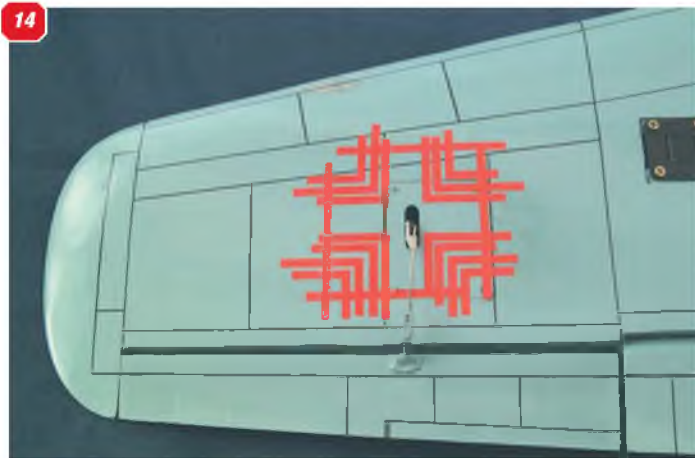

14: WW2 Luftwaffe aircraft camouflage were all straight lines, meaning they're easy, if a bit slow, to mask up. **15:** Painting the black cross and semi outline, showing the cross before application of the white in-fill (brushed without masking - any errors can be touched up!). **16:** I gave up trying to fit the fuselage-mounted doors. As a result only the main legs have doors fitted. **17:** I fitted a GWS Gyro on the elevator, set at full gain, to combat porpoising in pitch. Installed here, with the gyro adjacent to the receiver and a separate mini servo operating the steerable nosewheel. **18:** On the top of the nose, under a hatch, is the access to the I.C. fuel tank, the EP flight pack.

Techno Scale Mike Evatt wa

Aerobertics is a shop specialising in R/C model aeroplanes situated in Sijsele, near Bruges and maintains a website at www.aerobertics.be. Here you will find the Robbe 'Pander D', ARF model with 1.80 metre wingspan. Dutchman Henk Pander, originally a furniture factory director, founded the 'Nederlandse Fabriek van Vliegtuigen H. Pander & Zonen' in 1924 and began with building an improved version of the VIH Holland H.2, renamed as the Pander D. The aircraft was conceived as a light, single seater aerobatic monoplane for use as a military training aircraft. The model is of ply construction and covered with heat shrink fabric. Fitted with the recommended ROXXY(r) Brushless-Motor, aerobatics and tug duties are possible with this old-time model.

Are you bored with the usual plain model pilots? Well this creative caricature pilot bust adds some lighthearted fun into any model to which it is fitted. To save weight it is moulded hollow from tough plastic and comes pre-painted with incredible detail

leaving you nothing to do but install it. A range of **Slimline Xtreme Pilots** is available from Sussex Model Centre at www.sussex-model-centre.co.uk. Each is about 85mm tall and wide. I particularly like Fly Boy shown in the screen-shot.

I always like returning to VFSAA's website at <http://vfsaa.org.au> to enjoy the photo galleries.

The **Victorian Flying Scale Aircraft Association Inc.** is a special interest group that promotes the building and flying of radio control scale model aircraft in Victoria, Australia. The **VFSAA** is not a club, but a group of modellers with a common interest in building and flying scale models. The VFSAA conducts competitions each year. It is at these events where our members can display and fly their scale models during the year within the different classes of radio models. The association is also responsible for conducting the State Scale Championships and when the National Championships are held in Victoria, the VFSAA is also manages and runs the scale events.

It seems likely that the Worcester Model

Aero Club is the oldest model flying club in the world. It was formed in 1909; the same year that Louis Bleriot made his historic 40-minute flight across the channel.

The **Worcester Model Aero Club** caters for all aspects of fixed wing model flying, and they fly models ranging from small 24" wingspan up to 30% petrol engined scale airplanes. They have some very experienced modellers who lovingly hand craft their own models either from plans or commercial wood kits, and those who happily buy from the wide range of 'Almost Ready To Fly' kits. Many excellent photos of scale subjects feature on their website at www.worcestermodelaeroclub.co.uk

The radical design and look of the full-scale **P3 Revolution**, built for Skip Stewart Airshows, has once again been modelled by the **Horizon Hobby** camp in a slightly larger version than the UMX P3 Revolution announced in early August of this year. The Hangar 9 60cc version of this impressive 3D biplane sports the lines and livery of the original, and has been adapted for RC by designer Mike

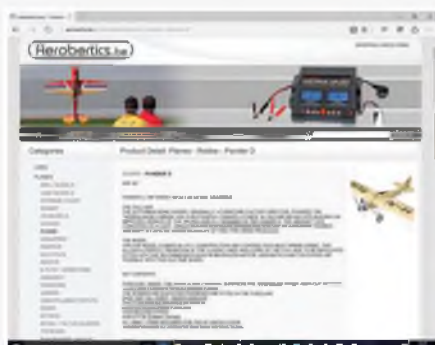

The Robbe 'Pander D', ARF model with 1.80 metre wingspan.

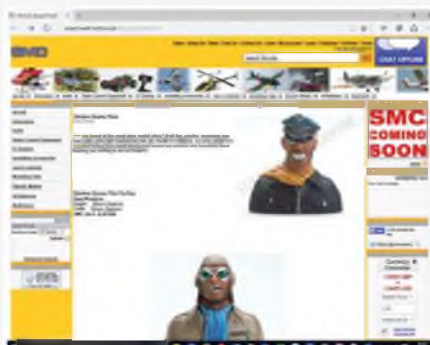

Are you bored of the usual plain model pilots? Then try "Fly Boy".



The VFSAA website has excellent photo galleries.



It seems likely that the Worcester Model Aero Club is the oldest model flying club in the world.



The radical design and look of the P3 Revolution.



This 65% Fokker DR-1 Triplane shown in the screen-shot is a real crowd puller.

Links the web for more TechnoScale Topics...

McConville. Although the full-scale P3 is still in development, you can fly the Hangar 9 60cc version!

Check it out on the **Flying Giants** website at www.flyinggiants.com

If big is your bag then look no further. Bill Hempel's Team Edge website at www.billhempel.com is the home of the World's Largest ARF's. The beautiful Fokker DR-1 Triplane shown in the screen-shot is a real crowd puller. At 65% Scale, this is the tallest RC airplane in the ARF history standing in at a 78" tall! The model is covered in high quality Ultracote finish and can be completed in almost any scheme you can think of. Because this is a custom order aircraft, you get to choose the scheme that you like! It is designed for motors of 275cc and larger.

The **de Havilland Mosquito Page** at www.mossie.org is maintained by Dr Andy Dawson. This is quite an amazing resource for those wishing to research the 'Mossie' in detail. You could stay logged on for hours. Not only is there much archive material and excellent photo galleries of the full size aircraft but also some good images of

flying scale versions.

Power Scale Soaring is all about building and flying scale model gliders of full sized jet, rocket or piston powered aircraft, excluding powered gliders. These basic guidelines enable the modeller to construct slope soarers based on a huge variety of full sized aircraft. Power Scale Soaring Association's website at www.pssaonline.co.uk reveals all. Classic airliners make good PSS models with their large wing areas and small diameter turbo jets. The Boeing 707 has been well proven off the slope over the years, in both civil and military guise. Rick Munsch's O/D Boeing 707 is shown in the screen-shot. At approx. 1/25th scale the model spans 71" and weighs in at 6lb 12oz.

John Salt built and maintains www.rchelicopterafun.com to help answer many common questions related to this relatively 'technical hobby' of flying R/C helicopters. From toy to turbine, micro to multi-rotor; information, advice, tips, recommendations, and guidance to help you succeed and avoid many of the common mistakes and pitfalls so many

experience when first starting out. There is a very section on Scale helis as well.

Hobby Barn has been a family-run business since 1970 and it is a pioneer in the field. They specialize in radio control aircraft, helicopters, multi-rotors, cars, trucks, and boats. However I also spotted on their website at www.hobbybarn.com a Beechcraft Staggerwing kit for Control-line! National C/L Scale winner Mike Stott has designed a neat 1/2A C/L semi-scale profile model of the classic Beechcraft Staggerwing. Simple construction and a generous amount of wing area combine to lower the wing loading. This results in outstanding flight performance.

If you need to buy or replace an electric motor for helicopter or fixed wing then take a look at the vast selection available from **Hacker** at www.hacker-motor-shop.com Here you will find a massive selection to suit all pockets and airframes. They also have a brand new Hacker eCalc setup calculator on-line to help you sort out propeller size, battery configuration and what thrust is available. ■



The de Havilland Mosquito Page contains a wealth of information.



Classic airliners make good PSS models with their large wings and small diameter turbo jets.



Perhaps all you need to know about RC Helicopters.



A Beechcraft Staggerwing kit for Control-line from Hobby Barn.



Hacker have a massive selection of electric motors to suit all pockets and airframes.



That's all there is time for from me this month so fire up the browser and if you find something out there of interest that might be good to share, email me at:

mikeevatt@hotmail.com

This may be our last R/C Scale Nats at hallowed RAF Barkston Heath. So for some, despite the joy of being together again, there was a touch of melancholy in the air. For me, The BMFA Scale Nats provide the pinnacle of my summer, and it was good to just watch in awe, one more time.

There is something deeply satisfying about observing superb scale models flying one after another, with that wonderful Barkston backdrop. Many of the competitors were flying well tempered glow and petrol engines, whose sound and smell somehow makes the summer.

However, the big news is that, after a superb long Saturday of some sunshine and manageable winds, the deteriorating

weather then played havoc with all the competition schedules. For most of us, the torrential rain on Monday just put the fin hat on it. All credit to Contest Director, the doughty Chris Allen, who did wonders to get things as good as they could possibly be under such heavily adverse circumstances. He deserves a medal, and his dog Biggles, deserves a nice juicy bone.

Entries

Total entries, at 27, were down compared to last year, when we had over forty. The 2015 entries by Class were:

F4C:	11
Stand-Off Scale:	6
Flying Only:	10

However, I did spot a number of new models to gladden the heart and delight the senses.

Ryan Brougham

Lord of Scale Martin Fardell is a pastmaster at digging out intriguing scale subjects. His new 'Tween-the-Wars silver dope finished monoplane looked a bit like a Bellanca Skyrocket until I got up closer. In fact, it is a Ryan Brougham and in Martin's inimitable style, conveys all the character of the prototype. I really liked it. Martin's scratch built model is to 1/5th scale, and weighs 12lbs. She is electric powered, with an eight-cell power pack.

The model is covered in Sig Koverall and Martin reports that the undercarriage was difficult to build - and that she could do



**BMFA
R/C SCALE NATS**

with a bit of dihedral, I thought she looked wonderful in the air. She placed 5th in Stand-Off Scale. Despite the unaccommodating weather I was able to grab a good number of detailed shots of this appealing scale model, so watch this space.

Tachikawa Ki 19

Welsh Lord Of Scale, Jeff Hartnoll was campaigning a new biplane. This new WWII subject was as obscure as she was fascinating. Entered into Flying Only, this was a beautifully finished and weathered Japanese Tachikawa Ki 19. Allied recognition name: 'Spruce'. More correctly, I suppose that she is a form of sesquiplane, with a shorter lower wing. The large radial engine is a very

appealing feature, which Jeff has modelled very convincingly.

The original first flew in January 1935, and later versions sported this bright orange trainer scheme. Such trainers with this scheme were sometimes nick-named 'ake tomo', or 'Red Dragonfly'. As well as their trainer role, some claim that they saw action too, and a few may have been used as kamikazes. Geoff's model is built to 1:4.5 scale, weighs 23lbs, and is Laser 300V powered. To my eyes she looked just right in the air, though Jeff reckons she is overpowered. Full details soon.

Tiger Moth

Fellow Welsh Lord Of Scale, John Thomas's new Tiger Moth caught my

attention. This was because she was so nicely finished, but also because she was built from the venerable and well-beloved Flair kit. She is quarter-scale, and is powered by an NGH 38CC petrol, driving a 20"x8" prop, which John says is deliberately over-propping her. She certainly did not lack power. The attractive scheme is from the RAF Central Flying School.

Cessna 150F

John Elkington's new model is a splendid Reims Cessna 150F, in a bright red and white scheme. I once built the .25 sized Pilot 152 Aerobat in very similar colours, so I was already a Cessna lover. In fact, John learned to fly in the full size version. Model has lights and flaps, and was built

GOOD SCALE NATS CROWD ON THE SUNNY SATURDAY.



FA NATS 2015

ALEX WHATTAKER MINGLES WITH THE LORDS OF SCALE AT, POSSIBLY, THE LAST BARKSTON SCALE NATS



Jim Reeves and daughter Anya Robyn Reeves fettle that wayward hatch.



Steve Fish carrying his Typhoon 1b out to win Stand Off Scale. Great pilot.



Contest Director Chris Allen did extremely well against adverse circumstances.



Safety First: BMFA Nats Transmitter Control Test Certificate.



Some Callers and Pilots used simple aide memoires to list their manoeuvres.



Dave Toyer (left) calls as Richard Crapp steers his mighty Wessex around the sky.

by John's very accomplished son Ben. She is Zenoh 45 powered. More details soon.

Cirrus SR22T

Under current rules ARTFs are eligible for the Flying Only Class, and David Fisher entered his fascinating and immaculately finished Cirrus SR22T. I thought it was gratifying to see a model of a modern light aircraft in the running alongside all the various military types. The model has a moulded GRP fuselage, spans 96 inches, and weighs around 17 lbs. She is built to 21% scale from the *Hangar 9* kit, and is

powered by an Evolution petrol engine.

Originally David fitted a 19"x10" prop, later dropped to an 18"x6", since she was somewhat over-powered. She has flaps and the doors are removable. The fit of the doors has to be seen to be believed. She was a big hit with the crowd and the other pilots due to her superb looks and smooth flying qualities.

Gremlins

This year's R/C Scale Nats was remarkable for the number of aborted or curtailed flights due to engine faults or, in the case of Jim Reeves' electric model, a hatch

that would not stay put! We are used to exquisite engine preparation at this level of competition, but very strangely, a number of The Big Names suffered power plant issues this year. Engines that had performed peerlessly all season suddenly seemed temperamental. For those of us normal mortals with feet of clay, this was oddly reassuring.

F4C

Once again, David Womersley flew immaculately with his continuously improved De Havilland Chipmunk and nabbed the top podium. Dave Knott was





Martin Fardell's fine 1/5th scale Ryan Brougham. Finished in Sig Koverall.



Richard Crapp's amazing 1/5th scale / 15 kgs Westland Wessex.



Sandie Reeves helps Mick start the Laser 350 V-Twin in his 1:3.6 scale Sopwith 1 1/2 Strutter.



Cowling detail on Martin Fardell's electric powered Ryan Brougham. Weighs 12lbs.



Richard Crapp's astounding Wessex has three engines, one Laser 120 and two Laser 75s.



Fighting the wind, Mick Reeves' 1:3.6 scale Sopwith 1 1/2 Strutter almost took my wig off... Great fun!

runner-up with his nifty Mk.I Hawker Hurricane, flown with great discipline, I might add: no racing about and silly turns that we so often see at other scale venues.

Placing 3rd, and flying what I believe is the best British scale model currently in the air, was Mick

Henderson. Every year I worship at the shrine of the DH9A, and every year I am not disappointed. This model embodies the spirit of the original scale subject, and is a delight from every angle. She is a magnificent flying machine.

amusing Lord Of Scale Peter Fullard flew his Westland Wyvern. Pete has added yet more detail and scale patina to a SOS model that - incredibly - started life as a *Black Horse* ARTF kit. She is fitted with a Laser 300 V-Twin, driving a 25"x10" prop. Naturally she has flaps and retracts.

Pete has rounded-out the fuselage to scale section, and recently altered the

Stand-Off Scale

Well loved and extremely



Welsh Ace, Jeff Harnoll concentrating hard on piloting his Tachikawa Ki 19.



DAVE CHARLES (SON OF WORLD CHAMP MICK) FLEW HIS LASER 150 POWERED SPITFIRE MK IXC. BRYAN TAYLOR PLAN.



David Fisher's very smart Cirrus SR22T from the Hangar 9 ARTF kit.



Stunning cockpit on Mick Henderson's magisterial 1/4 scale Airco DH9A.



Jeff Hamoll's new and extremely rare Japanese Tachikawa Ki 19 . Laser 300V power.



David Fisher with his Cirrus SR22T. 96" span, 21% scale, and Evolution 33 petrol power.



Mick Henderson's 1/4 scale Airco DH9A wafes majestically into the aether.



Jeff Hamoll's superb 1:4.5 scale. Tachikawa Ki 19. Allied recognition name: Spruce.

nose area, as well as applying a range of other detailed improvements. I saw Pete fly one of his best comp flights ever, which we all know pleased him, because he told us so! He got into the Top Three, placing 3rd.

Second was Jim McCall with his truly impeccable Spacewalker, which we featured in these pages last year. Jim hand painted this model which looks like it has been professionally sprayed. Once again, Steve

time-after-time, with his superbly observed Tiffie.

Flying Only

Mike Sollitt triumphed in Flying Only with his new Laser 180 powered Hangar 9 Mustang. This put David Osborne into Second place with his electric powered North American OV-10 Bronco. This began life as a 1/5th scale *Wilson Li / YT International* ARTF kit. She weighs 40 lbs and has been much reworked. She flew

'Coolhand' Fish flew his lovely Hawker Typhoon 1b to First Place. Steve never gets agitated. He just turns in an excellent flight

David Osborne's 1/5th scale electric Bronco. Twin Axi 2328 out-runners, driving 17"x12" props.



MR MURRAY'S 20 YEAR OLD TIGER MOTH FROM THE AULD PREMIER KIT. 66" SPAN, 1/6TH SCALE, OS 91 FS POWER.



**JIM MCCALL'S
EXQUISITE
SPACEWALKER.
1/3RD SCALE
FROM THE SIG KIT.
MVVS 40CC
PETROL ENGINE,
102" SPAN.
ADORABLE.**

extremely smoothly on her twin Axi 2328 out-runners, driving 17"x12" props. Third place went to David Fisher with his fore-mentioned, and intriguing, Cirrus SR22 ARTF.

David Womersley's continuously improved 1/4 scale DHC Chipmunk MK 10. Laser 180 powered. First in F4C.



The Verdict

Before the weather intervened, we all felt that this was the best Nats for some time. Even driving home early in the deluge I knew we'd all had a very good time. It is hard to put into words, but simply

standing and watching such superb scale models being flown in an appropriate manner is a pleasure that never cloys. It was doubly rewarding for us scale types, because when the R/C scale line ended for the day, we then had two good evenings of

Free Flight Scale comp flying. Sadly, it may well be the closing chapter at Barkston. This would be a great shame. Somehow the RAF tarmac, the tower, and



Dave Toyer's Laser 180 powered Miles Messenger. Troubled a bit by the wind, but a stunning scale model.



Tim Rucks lovely Mosquito IX lands with a flamed-out starboard Laser 70.



Jim Currie's immaculate Tiger Moth on short finals. SC 180 engine. Hidden pilot is tying his shoe laces.



John Elkington's new Rheims Cessna 150F. Built by son Ben. Zenoah 45 powered.



John Thomas's new 1/4 scale Tiger Moth from the venerable Flair kit. NGH 38cc petrol engine, driving a 20"x8" prop.



Andy Bowman steadies Alan Glover's Pitts Special.



John Carpenter's cute Pobjoy-engined, scratch-built, Comper Swift. Laser 180 powered.



Alan Glover's pretty 1:3.5 scale Pitts Special. Saito 300 Twin, driving a 21"x8" prop.



Steve Jackson's lovely 1/4 scale Avro 504 K. Laser 360 V Twin power. Based on the Hendon exhibit.

the rural Lincolnshire countryside matches our scale types better than almost anywhere else. If indeed we do not return next year, it will be the end of an era.

Acknowledgements

Grateful thanks to Michael 'Crash' Parry who came out of retirement to gather model details for me. Thanks also to Trish Dennis and Gordon Warburton for the efficient Official Results Service. We were given good service by all the various Scale Commentators over an extremely high fidelity PA System. Last but not least, utterly unflappable Contest Director Christopher Allen made a bad situation good.

RESULTS

F4C

- | | |
|-------------------|-----------------|
| 1 David Womersley | Chipmunk T Mk10 |
| 2 Dave Knott | Hurricane MK1 |
| 3 Mick Henderson | Airco DH9A |

- | |
|--------------|
| 2 Jim McCall |
| 3 P Fullard |

Spacewalker
Westland Wyvern

Flying Only

Stand off Scale

- | | |
|--------------|-------------------|
| 1 Steve Fish | Hawker Typhoon 1b |
|--------------|-------------------|

- | |
|-------------|
| 1 M Sollitt |
| 2 D Osborne |
| 3 D Fisher |

N.A. P-51D Mustang
Rockwell OV10 Bronco
Cirrus SR22T



**DAVE KNOTT'S
HURRICANE MK1
CROSSING THE
BOUNDARY ON A
FULL FLAP
APPROACH.**

AeroDetail series

Making a scale model?

Finding the detail needed to finish a scale model can be difficult and getting full size images is not always practical. Our range of detail photo collections provides extensive close ups of a wide range of popular aircraft all on CD in J-peg format



Junkers Ju87G-2 Stuka CD65

The aircraft that defined the term

Hawker Typhoon CD109

The Hawker Typhoon was a British single-seat fighter bomber, produced by Hawker Aircraft. While the Typhoon was designed to be a medium-high altitude interceptor. 117 images

Hawker Tomtit CD64

Mid 1930s RAF biplane trainer aircraft, from the era open cockpits of silver dope and polished metal. (140 images)

Hawker Tempest Mk 2 CD63

The final development of Hawker

Hawker Sea Fury FB XI CD62

Hottest of all the piston-engine fighter aircraft, the carrier-borne Sea Fury is also admired for its elegant profile. (140 images)

Hawker Hurricane MK1 & MKIV CD61

Two versions of the famous 'Hurri' - one a true Battle of Britain survivor painstakingly restored to perfect authenticity, plus the cannon-armed, Mk.IV 'tank buster'. (170 images)

Hawker Hart & Hind CD60

A combo collection featuring the RAF Museum's Hart bomber and Hart Trainer, plus Shuttleworth's Hind. (115 images)

Hawker Fury CD59

No authentic example now exists, but the accurate replica photographed in extensive detail in this collection is as good a guide as can be found of this elegant 1930s RAF fighter. Includes some general arrangement pictures authentic to the period. (55 Images)

Grumman FM-2 Wildcat CD58

First of Grumman's highly successful line of prop-driven 'Cats', the Wildcat, in guises from F4F-3 to FM-2 held the line after the Pearl Harbour attack and served from then until the end of WW2. It was idea for operations from the small escort carriers. (90 images)

Grumman F8F Bearcat CD57

Hottest of Grumman's prop-drive fighters - it arrived too late for action in WW2 but was standard ship-borne fighter equipment in the immediate post-WW2 era. (90 images)

Grumman F7F Tigercat CD56

The awesome twin engine long range fighter of the late WW2 era operated by US Navy and US Marines. (90 Images)

Grumman F6F Hellcat CD55

The US Navy's most important, and most successful fighter of WW2, photographed, close-up, from nose to tail and wing tip to wing tip. Example shown is part of The Fighter Collection, based at Duxford. (90 images)

Grumman F3F CD54

A study of the faithfully replicated example of the 1930s U.S. Navy biplane as seen at the 2001 Flying Legends Show. (34 images)

Gloster Gladiator CD53

The Royal Air Force's last biplane fighter, star of late 1930s air shows and flown in combat during early WW2, including Battle of France, Battle of Britain, Mediterranean operations and North Africa. (50 images)

Fokker D.VIII CD52

The Fantasy of Flight Museum's example of the late WW1 Imperial German Air Service monoplane fighter, in full detail. (69 images)

Fokker D.VII CD51

The most famous of all the German fighter aircraft of WW1. The collection depicts the RAF Museum, Hendon's authentic, restored example. (44 images)

Focke Wulf FW 190A CD50

Germany's 'butcher bird' fighter of WW2, active on all combat fronts from 1941 onwards.

Fieseler Storch CD49

Arguably the first military STOL aircraft, this storky looking aircraft has long been a modellers' favourite. Two examples are represented, the machine at the Fantasy of Flight Museum in Florida and the RAF Museum Cosford's example. (90 images)

Fairey Gannet ASW1 & T.2 CD48

The Royal Navy's post-WW2 anti-submarine workhorse, that also served with a number of other air-arms. Most images are of Mk.T.2, that was more-or-less the same as the ASW.1. (110 images)

Fairchild Ranger CD47

Elegant U.S. high wing light aircraft in full detail. Two examples shown. (60 images)

Erco Ercoupe 415 & Avalon Ercoupe CD46

The elegant twin finned light/sport aircraft. Both original Type 415 and later Alon resurrection examples. (115 images)

DHC Chipmunk CD45

A bumper bundle of images that provides a vast array of detail pictures, plus photos of examples in both RAF trainer and civil colours. (70 images)

DH Tiger Moth CD44

Much close-up detail of civil register example, plus further detail of the IWM Duxford's example in Royal Navy trainer colours, showing the blind flying hood. (110 images)

De Havilland DH89 Dragon Rapide CD43

Graceful twin engine biplane airliner that saw service from pre-WW2 through to the mid 1950s. Several are still flying and three are shown in this picture collection. (100 images)

De Havilland DH84 Dragon CD42

Forerunner of the more famous DH 89 Dragon Rapide, this collection depicts a superbly restored example. (40 images)

DE Havilland DH 60 CD41

The aircraft that set the British 'club' flying movement on the road to success during the 1930s. (140 images)

De Havilland DH 53 CD40

1920s lightweight low wing sports aircraft designed to a low-power specification. Machine illustrated is the sole remaining example. (60 images)

Curtiss P-40M CD39

One of the later versions of the famous Curtiss Warhawk, the WW2 fighter aircraft that saw service in just about every combat theatre of operations. (100 images)

Curtiss P-40B Tomahawk CD38

Rare, full restored example of the early version of the Curtiss fighter aircraft that was at Pearl Harbour on Dec. 7th 1941 - and survived the attack! (130 images)

Curtiss Jn-4 'Jenny' CD37

An authentic, restored example in full detail. (130 images)

Curtiss Hawk 75 CD36

The 'export' version of the Curtiss P-36 that saw service in during WW2 with Finland and during the 'Battle of France' in May/June 1940. Example shown is a combat veteran. (130 images)

Comper Swift CD35

1930s racing aircraft. Example depicted is the radial engine example at Shuttleworth Mussel (91 images)

Cierva C.30 Autogiro CD34

A study of the example hung in the Fantasy of Flight Museum, finished in RAF WW2 colours. (35 images)

Christen Eagle CD33

The spectacular, stylish aerobatic biplane revealed in close-up. Example shown is the two-seat version. (90 images)

Chrislea Super Ace CD32

Late 1940s civil light aircraft with distinctive twin fins and nosewheel type undercarriage. A fully restored example. (123 images)

Chilton DW1 CD31

Original upright engine version of this diminutive British low wing sports/racer. (90 images)

Chance Vought F4U-1D Corsair CD30

The famous 'bent wing bird' in super detail. (132 images)

Bucker Jungmeister CD29

Radial engine version. Example from Fantasy of Flight Museum. (79 images)

Bucker Bestmann CD28

Authentic example as exhibited at the Fantasy of Flight Museum, in WW2 Luftwaffe colour scheme. (43 images)

Bristol M.1C CD27

Early WW1 fighter monoplane. Example depicted is the faithfully authentic replica built by the Northern Aero Works and operated by the Shuttleworth Trust museum. (100 images)

Bristol F2B Brisfit CD26

Full close-up detail, including photos of engine cowls for both Rolls Royce Falcon and Hispano-Suiza engines. (28 images)

Bristol Bulldog CD25

This collection depicts the example assembled from two donor airframes and restored to superb standard by Skysport Engineering. It can now be seen at the Royal Air Force museum, Hendon. (60 images)

Boeing Pt-13/17 Stearman CD24

Subject aircraft is a current British civil register example used for air-show displays. (54 images)

Bleriot Monoplane CD23

The Shuttleworth Museum's machine, the oldest original example still flying. Much close-up detail showing all the exposed rigging, structure and the "bedstead" main undercarriage, plus Anzani engine. (74 images)

Bell P-39Q Airacobra CD22

Superbly restored example of this much-maligned WW2 fighter aircraft that was used with great success by Russian forces in the ground attack role and with saw much action in the south Pacific, from where this restored example was recovered. (130 images)

Beech D18 Staggerwing CD21

The distinctive back-staggered 1930s biplane with retracting undercarriage. (45 images)

Avro 504k CD20

The Shuttleworth Museum's superbly maintained machine, in full detail. (140 images)

Arrow Active II CD19

Sole remaining example of this 1930s racing and aerobatic biplane restored to pristine condition. (50 images)

Aeronca Sedan CD18

The last and most graceful of the Aeronca line of light/sports aircraft in fine detail. (80 images)

See many more online at flying scale models.com

ORDER FORM - Aerodetail CDs

Please send me the following CDs:

Name:

Address:

Postcode:

Daytime Tel No:

Enclose a cheque for £

(Made payable to ADH Publishing)

Please debit my credit card for £

(VISA / Mastercard - please delete non-applicable)

Card No:

Expiry date:

CCV:

SIGNATURE:

DATE:

Order on line at

www.flyingscalemodels.com or aero-modeller.com



£12.99 (including p+p)* per CD *UK only
Postage: (Europe); £2.50 (World); £3.50

Send to:

ADH Publishing Ltd,
Doolittle Mill, Doolittle Lane, Totterhoe,
Bedfordshire, LU6 1QX. Great Britain.
Tel: 01525 222573 Fax: 01525 222574
Email: enquiries@adhpublishing.com
Allow 21 days for delivery

THE QUIET ZONE

R/C SCALE ELECTRICS WITH
PETER RAKE

Yes, there's no getting away from it, it's time for another rambling episode of electric flight nonsense. As the man once said. "You can run, but you

can't hide."

So, do we have lined up for you this time around? Well, rather than make you another more micro-model episode, or run on endlessly about detailing models I

thought I'd turn to something else I do from time to time.

Let's face it, there's really only so much a person can say about building tiny models without actually having one to use as an example, and we all have our own individual ways of detailing our creations. Mind you, none of that is to say that you won't be regaled with just those subjects in the future, but not this time around. After all, I have to keep something in reserve with which to entertain (punish) you. Oh come off it, it's no use you pretending to complain, I know you enjoy it really.

Right then, with the waffling preamble over with I suppose I'd better explain just what it is that I do actually have in store for you this month. Well, if you're a regular reader of this column (for which read in masochist), you'll know that from time to time I like to feature the models of individual builders. So, like it or not, that's roughly what I have in mind for this edition of the column. Okay then, I'll admit it, I couldn't think of anything else to write about at the moment. This time, however, there is something of a twist involved.

FIRST OFF ...

For anyone who reads Flying Scale Models on anything like a regular basis, this particular builder's name will be only too familiar. You will also have noticed that, as well as driving you to distraction with this column, I have been known to design the odd model or two. Yes, I know some of them have been very odd, but you know full well that isn't what I mean in this particular context.

If you were asked to give a list of names from Flying Scale Models contributors

OUR COLUMNIST PAYS TRIBUTE TO THE STERLING WORK UNDERLAKEN BY PAT LYNCH, MARATHON TEST BUILDER FOR THE ONGOING RAKE DESIGN OFFICE!

Short, dumpy and pugnacious looking, the Albatros DX1 was another prototype build of a design available from the publisher. Pat's first experience of a lozenge finish.





Remembering that this is only Pat's second electric powered scale model and you can see the direction his modelling is likely to take.



The man himself. Pat Lynch poses with the prototype build Bristol. I suppose his pose means it was a success.



Proof of the pudding as the Bristol F2b cruises overhead. Want one yourself? Plans are available from the publisher.



A child only a mother could love, the B. A. T. Baboon was one of Pat's first prototype builds for me.

there are probably two that would appear on most of those lists. One, naturally, is Peter Rake (because he's the bloke making you suffer at this particular moment in time) and the other would be that builder of beautiful models - Pat Lynch.

Although not actually a contributor in the normal sense of the term, Pat has prototyped so many of my designs (including the free plan item in this issue) that you'd have been hard pushed to miss mention of him. Add in that his models are often so nicely detailed that I've built entire columns around what he did and how he did it, that I felt it was about time to take this slightly oblique opportunity to thank him for all the sterling work he's put in on my behalf, although, if I know Pat, right about now he's feeling a bit embarrassed by the very thought of such a thing. Well, sorry mate - credit where it's due!

A LITTLE HISTORY

No, nothing at all to do with Greeks and Romans, any fool can write about them (...and they've written enough about themselves anyway). The history this particular fool means is a little about Pat's modelling history, and how I came to know him.

Our association probably goes back

about ten years or so, when Pat was just starting to get into electric powered scale modelling. It was obvious he didn't have a clue what he was letting himself in for because, amongst the first models he built were two of my designs, the Eastbourne Monoplane and Fokker E.III (both of which are designs that have featured in FSM).

We 'met', if that's the correct term to use (because I live in the UK and Pat lives in Australia) through an on-line modelling forum where he was requesting guidance. Well, being the busy-body that I am, I could resist chiming in with ideas and a few suggestions about what to build, how to equip it and with what to power it. You know the sort of thing, the kind of information novice electrolites need to get them through those first few models.

What struck me as interesting was that despite being a self-confessed beginner, it very soon became obvious to all that Pat had all the makings of a very fine modeller indeed. Maybe some techniques needed a little refining, but his builds were extremely neat and tidy and the finished models really quite outstanding. I don't just mean outstanding 'for a beginner' either.

Having built the super simple Eastbourne Monoplane, and discovered that he liked the way it flew, the scale bug had well and truly 'bitten'. You know

how it goes, you have an initial success and the next model simply has to be more and better. In this case it was the Fokker E.III and the more-and-better parts involved more detail and a better scale appearance. A swirled finish metal cowl, scoops, fairing and even a tiny compass built into the wing (as per the original, to keep it away from the steel tube fuselage frame) were all fair game on this model.

Pat has a particular goal in mind when he starts a new model. He likes each one to stretch his abilities in some way. Whether that involves improved detail, greater detail, different building skills or simply a model that doesn't fly quite like the previous one doesn't matter, just so long as he learns something new from each build.

NOT ALL SUCCESS

As you might suspect, not all of Pat's early modelling was a success. Having learnt a bit, he fell into that same old trap we all do. Being extremely fond of early types (I can't think where that influence came from) and looking for an even greater challenge, Pat decided to 'roll his own' and start from with nothing more than a set of three view drawings. Unfortunately, he probably couldn't have chosen a much worse prototype to model. The Channel crossing Bleriot has all the



Why pick a pretty model when you can have something as interesting as Pat's own design Avro Bison.



You see, I told you there were ladders involved on the Avro 555. Lots of other nice details too.

potential for nightmare in the hands of a relatively inexperienced designer/pilot, and at this stage Pat was both of those things.

He started the build, doing an absolutely superb job of construction and detailing, but it soon became clear that he had really bitten off more than he could handle in terms of ending up with an actual flyable model. He had building and detailing skills in spades, but was still quite inexperienced in terms of what makes for a successful model.

HOOKED

Not to be deterred, although the Bleriot might not be working quite as he had intended, Pat started looking around for something that was within his flying capabilities - and that's when I pounced.

As I'm sure many of you are aware, just show me a decent builder who's willing to build one of my designs and I'll get plans to him double quick. Pat was looking for something to build, but hadn't got as far as a biplane, yet it didn't take too much persuading to talk him into prototyping a design for me.

What had I persuaded him to build, you ask; something elegant and quite famous;

something with an outstanding service career? Don't be silly, you know how I just love obscure types. At the time, I was being influenced by Walt Mooney rubber power designs and had been drawing up several models using them as inspiration. Since simple-and=somewhat-ungainly was also appealing to me at the time, the prototype Pat ended up with was the fairly unlovable (only loveable by its mother at any rate) B. A. T. Baboon, otherwise known as the FK-24.

Pat built it, photographed and flew it and it seemed the die was cast - I had my very own model prototyping factory - namely Pat. Although he builds carefully and precisely, doing a really nice job of finishing his models, he can also build them almost as fast as I draw them up!

Anyway, with the Baboon successfully built and flown it was time to move on. Pat only had to hint that he might be thinking of starting a new model and I'd whisk him a selection of designs to choose from and the Rake/Lynch aeroplane company came into being. Yes, I openly admit that I got the easy part, sitting comfortably in front of my computer, gradually honing my CAD drawing skills. It was poor old Pat that had to do all the

hard work of building, finishing, photographing and flying the models.

That, of course, means getting up at some unearthly hour to test fly the model, dragging his long suffering wife Liz along to record events. To both of you; my undying thanks.

So, with many, many models given the Lynch magic touch the list of prototypes is wide and varied. All are relatively early types of course because to draw up a design, the original has to appeal to me in the first place, and I don't (with a very few exceptions) do modern, or even relatively modern.

Between us we've seen WW1 scouts, pioneering types and even a couple of racers come together for your delectation. As to specific prototypes, there's been an SE5a, FE8, Fokker D.VII, a couple of Albatros types, Great Lakes Trainer, Avro Scout, Farman Moustique and many more, some famous, others potentially infamous and some downright obscure. All-in-all, there must have been around twenty models that Pat has prototyped... so that you lot out there get free plans to build from.

So as you see, when I titled this section 'hooked', I really wasn't joking. If it

In the case of the Ansaldo, it was the venerated fuselage, interesting camouflage and intricate marking that grabbed Pat's interest.



**Another Russian,
another prototype
build and another
on line competition
winner, the
Polikarpov Po-2.**



Just to prove that lots of detail isn't required to end up with a nice model, just a tidy finish. This one is the Russian AIR-1.

weren't for Pat, and other generous builders who've prototyped other designs for me, the list of plans available from the publisher would be a whole lot shorter.

AS IF THAT WEREN'T ENOUGH...

Considering the level of building skill involved, and the standard of detailing and finish, you'd think twenty models over a ten year period wasn't too bad going. Not for Pat however, because those are just the models he's prototyped for me. Remember that I did say he builds fairly quickly. He's also designed and built some quite stunning models of his own. Not by any means the least of those was his Avro Bison.

This model was designed for an informal on-line competition that is fairly interesting in itself. Normally if you're going in for this sort of thing, you pick a subject

that people will know, or one that's attractive to the eye. So, what does Pat do? He picks some large, ungainly (some would say downright homely) type that very few people will have even heard of, which just goes to show that I'm not the only one with a soft spot for ugly ducklings. The big difference is that that some would say my soft spot is between my ears. I sometimes even wonder if they might just be right.

Since the model was for a competition, albeit a relatively light hearted affair, Pat allowed himself to really go to town on this model. Litho plate panels, air scoops, ladders (yes ladders) and countless other little detail items were all fair game, and created to adorn the model. He's one of those people who thoroughly enjoys figuring out what details are needed, which can be omitted and how to make

the ones he will be installing - and make sure they stay where he puts them.

Well, you only have to look at the photos to see that it shouldn't come as too much of a surprise that Pat's Bison won the competition by some margin and he duly claimed his prize - a Balsa USA 1/4 scale SPAD XIII kit.

Oh yes, Pat has no objection to building from kits too. Kits, plans short kits and own designs; if it is intended to fly, offers to stretch his skills in some way and appeals to him Pat will have a go at building it. He's very much a builder, as evidenced by the number of partially completed airframes that show up in photos of his workshop. Most get finished, but there are still those that hang around for ages taunting him to get back to the, and failing miserably. In that respect he's no different to the rest of us, constantly on the lookout for our next project and putting a hold on already started models.

Pat has also had considerable success in local competitions and, I'm pleased to say, that includes with some of the models he has prototyped for me. Models like his Fokker DVII, Great Lakes Trainer and Polikarpov Po-2 have all done well for him. Just suffice it to say, by way of a closing comment, that Pat is not only an exceptional builder, he's also very obliging, helpful to other modellers and someone who thoroughly enjoys what he does. Now, having embarrassed him enough, I'll leave it there. I have a sneaking suspicion that there may just be another builder I can do a similar disavour at some point in the future.

In the meantime, you'll find me at the usual place, PETERAKE@aol.com ■

Classifieds



MANTUA MODELS UK LTD

Tel: 01753 856321 Fax: 01753 857444

179 Dedworth Road, Windsor, Berkshire, SL4 4JN

Open Mon-Sat 9.00 - 6.00pm

MANTUA AND AVIOMODELLI AIRCRAFT AND ACCESSORIES

Trade enquiries welcome for
our full range of aircraft

MASTERCARD/VISA

STEVE WEBB MODELS & HOBBIES

Tel: 01928 735225

Fax: 01928 735410

80 Church Street, Frodsham,
Cheshire, WA6 6QU

Mon-Sat 9.30am - 5.30pm **Closed Wednesdays**

MASTERCARD & VISA ACCEPTED

email: stevewebb@steve-web.demon.co.uk



adhbooks.com



WWW.FLYINGSCALEMODELS.COM

ADVERTISE HERE
THIS SPACE COULD BE WORKING FOR YOU. TO ADVERTISE IN THIS SPACE
PLEASE CONTACT SEAN ON: 01525 222573

The RC Hotel Corfu Greece

English speaking instructors. No more travelling for an
hours tuition every weekend. Everything is at your doorstep.

FLYING SCHOOL

Learn to fly fixed wing and helicopter while on a holiday.
Tuition from English speaking instructors. No more travelling for
an hours tuition every weekend. Everything is at your doorstep.

Visit our web site for more information. www.rchotel.com

Tel 00302661099322 Mob 00306982420044

Email spiro@rchotel.com or rchotel@kar.forthnet.gr

The RC Hotel, PO Box 1567, Pulades, 49083, Corfu, Greece

Vintage Limited Edition Prints



visit: www.aeromodeller.com for the full range



Vintage **AeroModeller** A3 Cover Artwork - *Limited Edition Prints*

NEW FROM ADH PUBLISHING

The Modeller's Guide

Superdetailing, Painting and Weathering

Aircraft of WWII, with airfield accessories, ordnance and diorama

The Modeller's Guide



SCALE MODELLING:
A LOVE STORY READY
TO ASSEMBLE

TOOLS AND MATERIALS

TECHNIQUES

BUILDING THE AIRCRAFT

- SPITFIRE MK. IXC
- P-47D THUNDERBOLT
- JU-87D 'STUKA'

MAKING A DIORAMA



Aleksandar Počuč

Modeller's guide to superdetailing, painting and weathering aircraft of WWII' book is intended for both beginners and advanced modellers as it covers wide variety of modelling tasks ranging from basic detailing, scratch-building, painting, weathering, machining custom parts using resin as well as scratch-building part from brass and aluminium and of course, diorama making. Basics about tools, paints and modelling materials have been covered as well. The book revolves around three subjects, P-47D Razorback, Spitfire Mk.IXc and Junkers Ju-87D Stuka, all in 32nd scale. Step by step concept will provide a good reference and ideas to all WWII aircraft modellers regardless of their experience.

ORDER NOW:



www.adhpublishing.com



01525 222573



enquiries@adhpublishing.com

FOR ONLY

£18.95

PLUS P&P



ADH PUBLISHING, Doolittle Mill, Doolittle Lane, Totternhoe, Bedfordshire, LU6 1QX, United Kingdom.
TEL: +44(0)1525 222573. FAX: +44(0)1525 222574. ONLINE: www.adhbooks.com

DURAEYE®



*The Curtiss
P-40R
Warhawk*

Available at hobbyking.com