



The Guillow model airplane company was founded in 1926 by Paul K. Guillow who was a US Navy ensign during World War I. His experience as a Navy pilot kindled in him a great interest in aviation and eventually led to the creation and marketing of a line of small balsa wood shelf model construction kits of famous World War I combat aircraft such as the French *SPAD*, German *Fokker D-7*, British *Sopwith Camel*, American *Thomas Morse Scout*, and many other historically famous biplane fighters.

The following year (1927) when Charles A. Lindberg flew the *Spirit of St. Louis* on the first successful solo flight across the Atlantic from New York to Paris, France, national interest in all matters pertaining to aviation zoomed, and Paul K. Guillow, with his fledgling model airplane kit company established, found his products in great demand.

Paul sold his first shelf model kits to a national variety chain and soon found himself besieged with orders, compelling him to rapidly expand his business to satisfy the demand.

The first line of Guillow balsa shelf model kits offered consisted of 12 different WW-I biplane fighters with 6-in. wing spans and retailed for 10¢ each. Each kit contained a 3-view plan, balsa wood cement, 2 bottles of colored dope, and a strip of bamboo for wing and landing gear struts. All in all, a great value, even in those distant days.

For several years up to the mid-30s, this initial line of balsa shelf model kits sold well all over the country, and, during the time, many more models were added, including a line of larger size models that sold for 25¢.

In the early 1930s, the Guillow company designed its first line of balsa flying model construction kits: models that were built of balsa strip stock and blocks, then covered with light model airplane tissue. When completed, these models could be hand launched and flown by rubber motor band and propeller.

Here again, a new line was successfully launched that became the forerunner of the extensive line of flying models still being manufactured by the Guillow company today. Needless to say, great strides have been made in the design and contents of a present day Guillow kit, compared to those first produced in the 1930s.

The Guillow company enjoyed great success in the market up to the WW-2 era, when balsa wood, which is imported solely from Ecuador, South America, became unavailable for civilian use during war time, when urgently needed by the US armed forces, especially for use in life rafts aboard US Navy

vessels. During this period, the Guillow company and other competitors who had entered the market turned to substitute materials, such as cardboard, domestic soft wood, etc., to continue in business.

Fortunately, Guillow designers were able to find ways to successfully use the substitute materials until the war ended in 1945. Immediately upon cessation of the hostilities, balsa wood became available again, much to the satisfaction of model builders who had enjoyed the hobby in the pre-war years.

From that period to date, Guillow has been a leader in the manufacture of balsa model airplane kits, both rubber and gas powered, some of which are radio controlled.

Guillow has specialized in one area: the design and production of scale model airplane kits. In this particular field, Guillow is a world leader, as attested to by the hundreds of complimentary letters received from model builders of all nationalities.

Although model airplane kits have been an important Guillow product for over 50 years, another balsa wood line has contributed equally to the Guillow reputation: ready-to-fly balsa wood gliders and rubber-powered motor planes. Millions of these inexpensive flyers are manufactured each year and distributed nationally and internationally in every country of the free world. Along with model construction

kits, ready-to-fly balsa planes have given Guillow a one-two punch in the market place and earned Guillow an exclusive niche in the American hobby business.

Today, Guillow is the largest producer of ready-to-fly balsa planes in the world, and, in spite of the attractions of TV and video games, the market for these "play planes" continues to grow. It is the opinion of the Guillow company and its employees that the future for balsa wood products is bright and that success is as certain in the 50 years ahead as in the 50 years past.

Lastly, the Guillow company is the only one in its field that has operated under the same original ownership and management since its conception in 1926. Although the founder, Paul K. Guillow, passed away in 1951, he left a legacy of hope and belief for those succeeding him that balsa wood products are and will remain attractive to legions of hobbyists of today, tomorrow, and beyond. His successors intend to turn his vision into reality with new products, new merchandising, and an emphasis on quality and service.

(Text courtesy of **Paul K. Guillow, Inc.**)



WORLD WAR I

DOG FIGHT!

A duel-to-the death in the skies over the Western Front

Just 50 years ago, the first Great War broke out in Western Europe and the heavier-than-air machine — a curiosity up to that time — began to create aviation history

Almost overnight, the warring powers were forced to develop fighting aircraft and these planes and their heroic pilots soon became the most glamorous combatants of the 1914-1918 war era.

Today, 50 years later, such names as "Fokker", "Camel" and "Spad" are acknowledged to be the forerunners of modern air power. The exploits of daring pilots like Bishop, Rickenbacker and Richthofen, plus a host of others, are imperishably engraved in history's pages and the passage of time has not dimmed the glory of their deeds or lessened the significance of their achievements.

For both flying fun and scale model building, Guillow offers you the most complete line of these truly historical aircraft. See them at your dealer today —

you'll be more than pleased with the contents and quality and, not least of all, the value in a Guillow kit.

BUILD ALL OF THESE FAMOUS WW-1 FIGHTERS

\$129

18" wing span rubber powered models ideal for .010 gas motor



Kit WW-1 German Albatros D5A



Kit WW-2 French Nieuport 28



Kit WW-3 French Spad



Kit WW-5 British SE-5



Kit WW-6 British Sopwith Camel



Kit WW-7 Bristol Bullet



Kit WW-4 German Fokker D7



Kit WW-8 Nieuport 27



Kit WW-9 Fokker D-8



Kit WW-10 Sopwith 7F1 Snipe



Kit WW-11 Pfalz D-3



Kit WW-12 Halberstadt CL 11

\$295

20" to 27" wing span — for rubber power or 1/4 A gas motor



Kit 203 Nieuport 11



Kit 201 Thomas Morse Scout



Kit 205 DeHavilland 4



Kit 204 Fokker DR-1 Tri Plane



Kit 202 British SE5A



Kit 206 Rumpler C-5

Also available many World War 2 and Private Plane models priced from 69¢ to \$4.95.

PAUL K. GUILLOW INC.

WAKEFIELD, MASS.



If kits are not available at Hobby Dealer, send direct to factory adding 25c packing & postage in U.S.A., 60c outside U.S.A.

MODEL AIRPLANE NEWS • August, 1964

Editor's note: This 1964 Guillow advertisement shows the full line of eighteen WW I kits that were introduced starting in 1957. Four of the kits (#201-204) are still in production! (Inb)

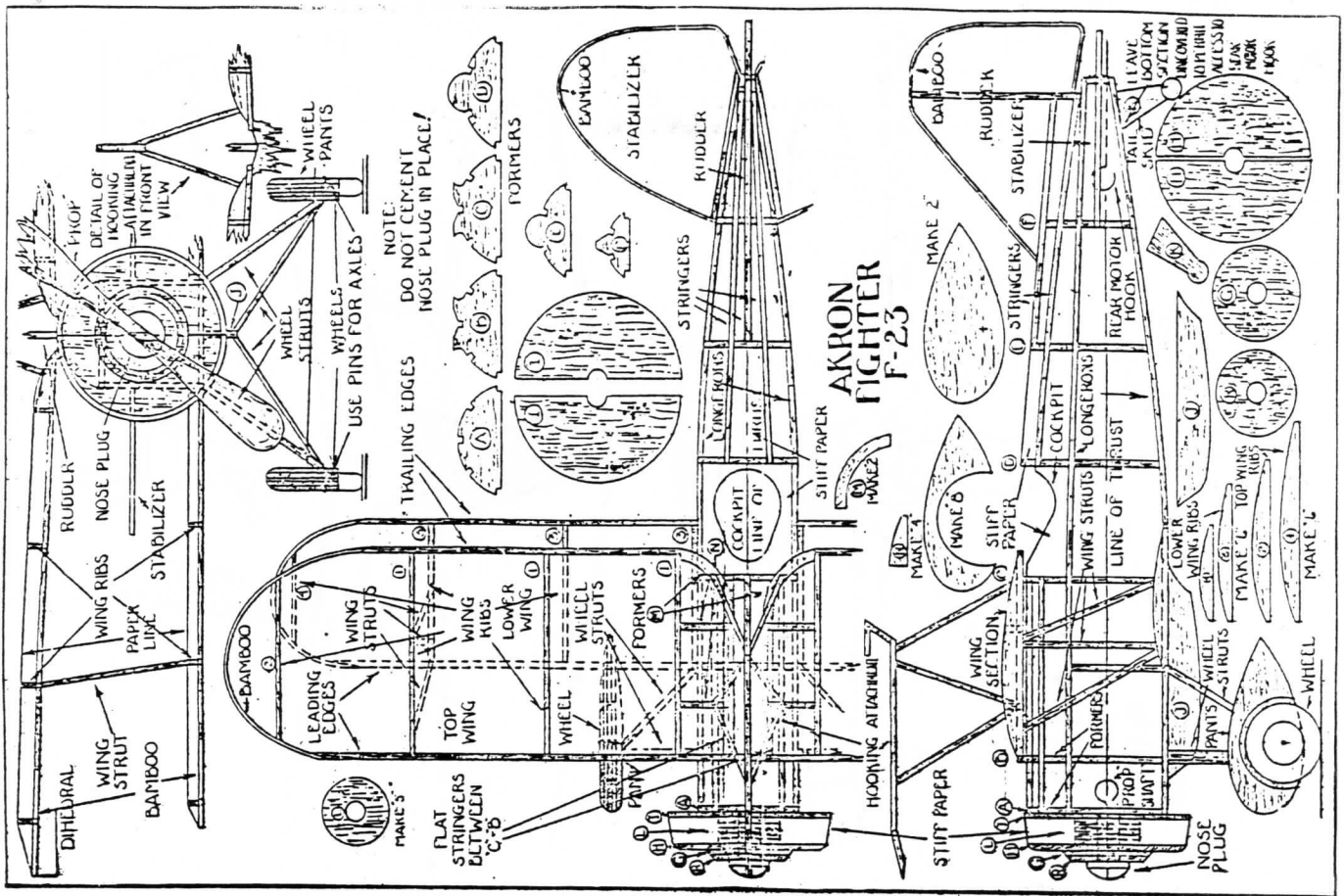

Reduced plan from 12" Akron Fighter 10-cent kit of about 1935.

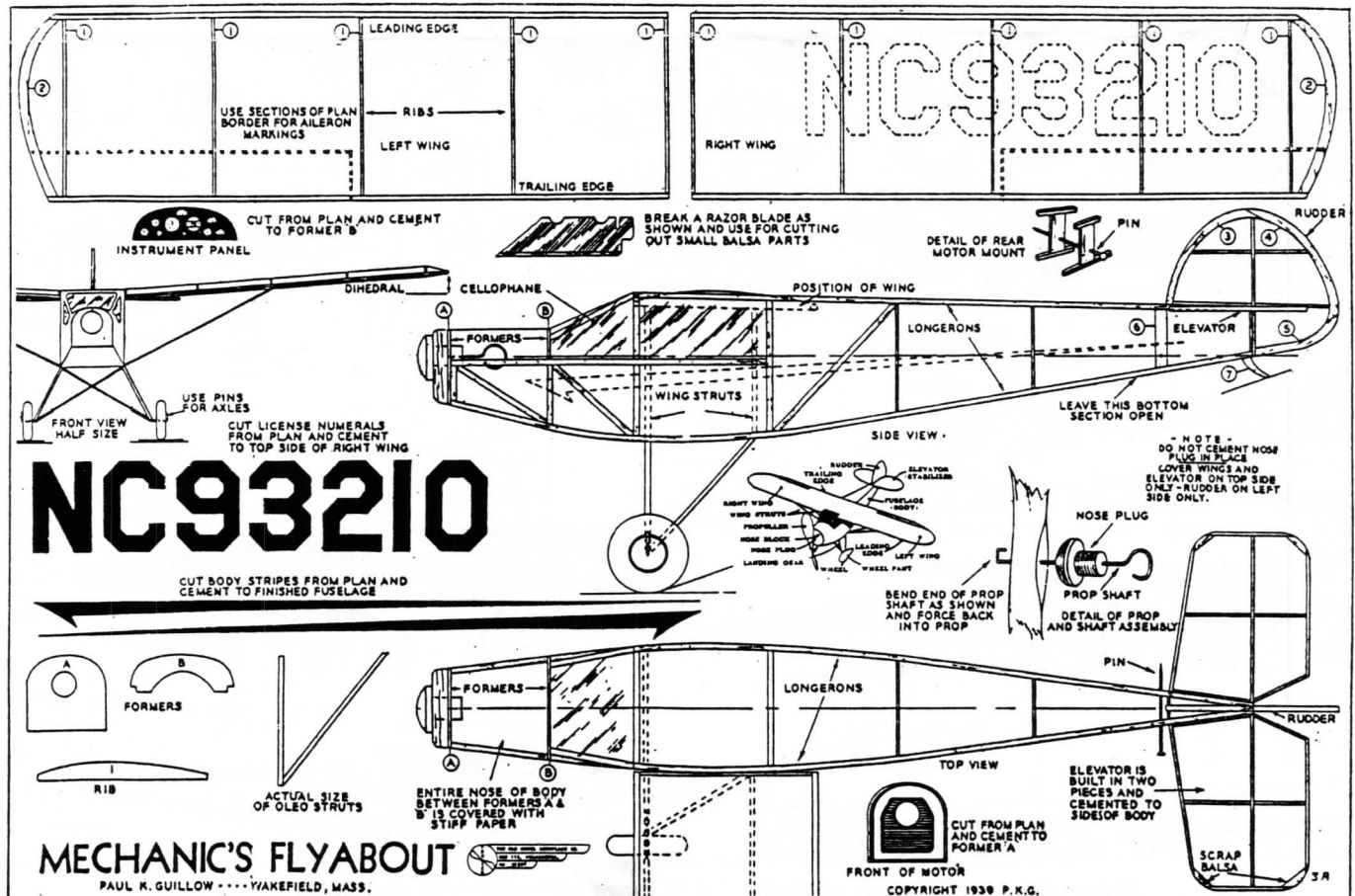

Reduced plan from 16" Mechanics Flyabout 10-cent kit of 1939.

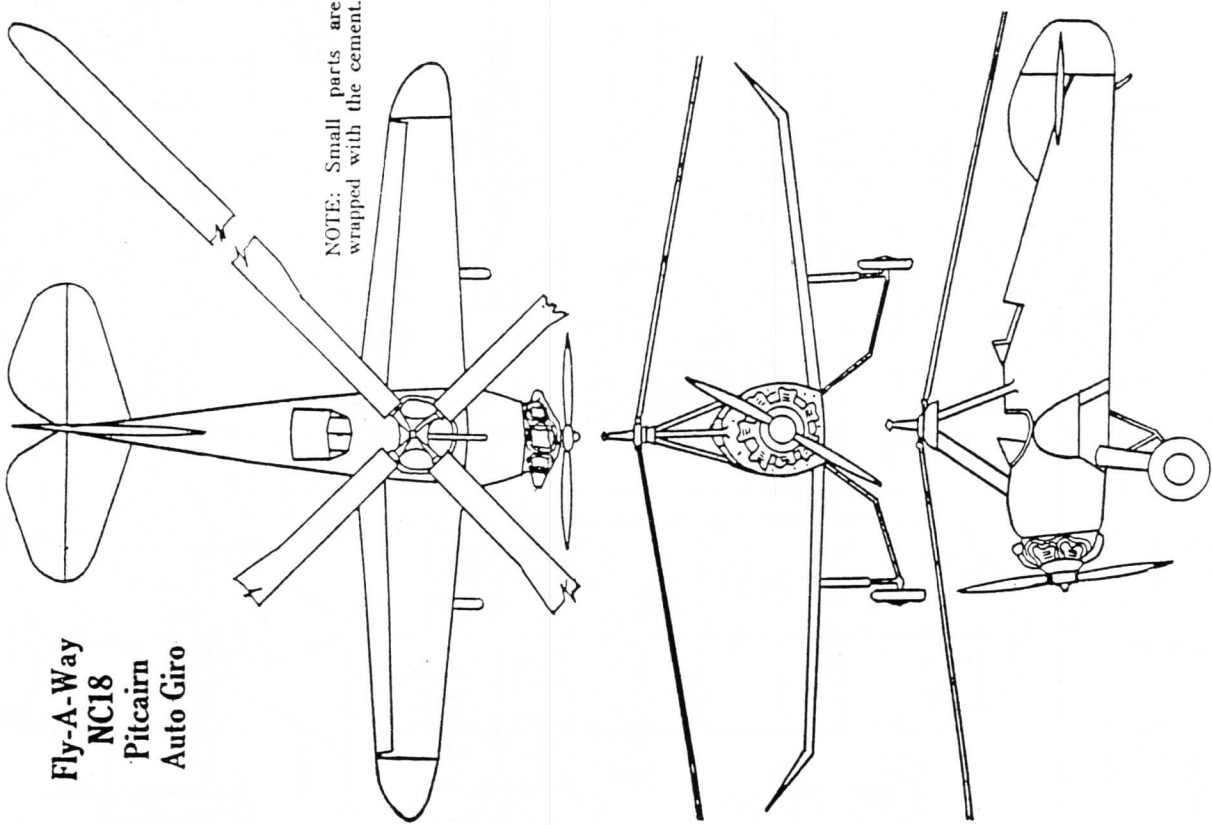

Reduced plan from 15-cent Pitcairn 5-3/8" span kit of 1933.

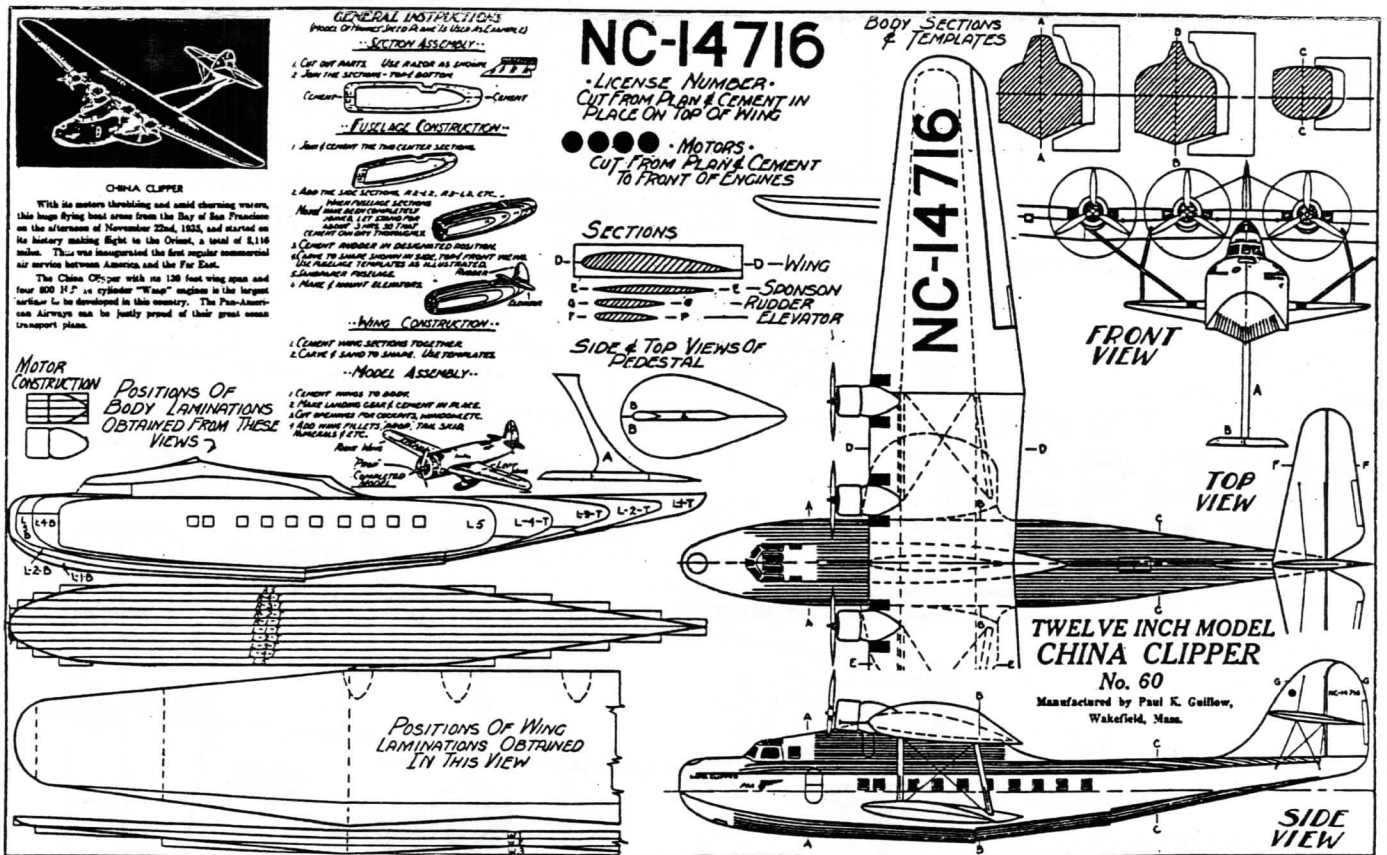

Reduced plan from 25-cent China Clipper 12" span kit, about 1937.

We had an opportunity to visit friends and relatives in England this summer. Costly, but there was no guarantee I or they would be around "next time", so we did it. Time allowed for two side trips, and I chose the International Model Centre and Museum at Goosedale, Nottingham, run by Mike and Val Ward—exceptionally fine people. Mike is the British version of our own late, wonderful Cole Palen—although Mike reminds me of the Paul Bunyan type. The museum, restaurant, grounds, and runways (grass, of course) for models and the 1:1 types are magical—gorgeous models hanging all over the place, mural backdrops, and model engines running outside. But as Mike says, look closely and you'd applaud the effort, not the image. I applauded both. Wish we had such a model theme park here in the US. The second visit was to the Imperial War Museum Aviation display at Duxford, where I spent hours going through five hangars of displayed and operational aircraft, got some cockpit time in a Yak-II, and went through a simulated dogfight as a pilot of an ME-109 against a couple of Spitfires. (I survived, but lost my section leader—some wingman I turned out to be!) I also spent quite some time in all the hobby shops I could find.

Speaking of hobby shops, I returned to find the September '94 issue of *Flying Models* with its superb article by Dick Sarpolus on An Antique Hobby Shop! Yes, there seems to be a modeler's "Shangri-La" located in Pomona, CA. (You guys have all the luck!) Grandpa's Antique Hobbies is owned by Mr. Vic Cunyningham, who sells what he has. Frankly, it would be a priceless experience simply to walk into the shop and feast my eyes for a while.

Though we may not be able to afford the prices, and be reluctant to build what we bought, old Jack Fike of Scale Flight Model Co., 1219 S. Washington, Bloomington, IN 47401 (tel: 812-339-8274) is churning out yet more replica flying and solid "Dime Scale" and other Comet, Megow, Peerless, Dallaire, Madison, Scientific, Burd, etc., kits—most of which are \$10.00 or less. Actually, as these themselves may someday be collector kits, you might buy two of whatever you want... "just in case". One of his many "newest" is a Megow solid Douglas DC-2 with an 8" ws for \$12.95 (with turned hardwood engine nacelles!), plus postage. Send him a large SASE for his growing list.

"*More Solid Model Stuff*" was the title of a 2-page article on a unique find by Don Campbell in the May 1994 issue of *Cloudbusters*, 1911 Carmanbrook Pkwy., Flint, MI 48507 (\$10/yr) Model Archaeology is alive and well in flea markets at times! A couple of exciting plans also appeared in *Max-Fax* (a whole issue devoted to the PZL fighter!) and in *Cloudbusters*, which featured plans for the Boeing Bomber (B-9) from the Construct-A-Plane Co. in their April 1994 issue.

I also finally got to read "*Do You Speak Model Airplane?*" by Dave Thornburg. What a fantastic book, and extremely well written and researched. Mr. Thornburg's writing style

could not be better. The personal touch, first-hand knowledge of models, men, manufacturers, and more was a wondrous reading experience. If you haven't yet gotten a copy, you are missing a great deal. You can get a copy for \$19.95 plus \$3.50 postage from Hannan's Runway, Box 210, Magalia, CA 95954.

Take a look (p. 9) at the neat photos sent by Walt Winicki of his and his son's Albatros and Pfalz. The lozenge patterns on the two Guillow's WW-I jewels were done with colored pencil on silk-span. Many of you wrote expressing your favorable comments about KAPA's new look—kudos to John Pothier and his wizard computer. All of you make KAPA possible...so let's hear more from you! You'd be surprised how much you know of this wonderful hobby/obsession that the rest of us would enjoy reading about, so how about writing what you know as a letter to us.

Many thanks to Jim Alaback—again—for his generosity in providing copies of Guillow's plans for you all to enjoy. Note that by reducing 11" x 17" plans, we can give you at least twice as many plans per issue—and you can blow them up or down to any scale you wish at your neighborhood photocopy machine. Thanks also to Morrie Leventhal for his tip on anti-silverfish strategy.

And a very special thanks to Guillow's and Walt Musciano for all they've done for our hobby. It was Walt's plans that drove me to scale-frenzy and led me to discover Cleveland 3/4" scale kits. It was Guillow's kits that made me look like sort of knew how to build anything and make them look good. I'm glad you guys were there when I was growing up. A few years earlier or later, and I would have missed a very great deal. And by the way, I called Guillow's to see if I had anything they needed, and I found out that I've been pronouncing their name wrong for over 40 years! I've been saying it as "Gillo", but they pronounce it as though it has a "w" in it: "Gwillow". (Hmmm... Anyone know the correct way to pronounce Musciano????)

Finally, an important note from the 'Keeper of the Membership List', Morrie Leventhal:

Please check the mailing label of this *Kollektor* issue to be sure that the name, address, city, state, and zip code are correct, including spelling.

If there are any errors, contact Morrie Leventhal, by mail at 1788 Niobe Avenue, Anaheim, CA 92804...or by phone at 714-535-6570 (if you get the answering machine, please leave corrected information in a message). In either case, please refer to your KAPA membership number--it's the first entry on the mailing label, in the upper left-hand corner.

The other entry on the top line is the expiration date--this is the last issue you will receive unless you renew. As in the past, a list of KAPA members is available to any member for \$5. If you don't want your name published on this list, please let Morrie know at the above address or phone number.

Roland D-2 "Wahlfisch"

by D.A. Newell

Editor's note: This design appeared in the Sep '49 issue of Air Trails and in Walt Musciano's 1954 book "Flying Scale Models of Famous Planes" (Inb)

Just what the doctor ordered! U-control biplane with pylon.

THE Black Knight of Germany," Hauptman Ritter E. von Schleich, leader of the "Bavarian Blue Tails," attained many of his thirty-five victories using the Roland D-2. Because of its streamlined shape, this plane was nicknamed "The Whale" (Wahlfisch), and many pilots painted a mouth and eyes on the nose to simulate a whale. Although used in action with success for quite some time, the "Whale" somehow never achieved the popularity of the Fokker and Albatros fighters. Unlike the average bullet-nosed planes with liquid-cooled engines, the D-2 did not have a radiator protruding into the airstream. Instead the radiator was cleverly concealed in the nose just behind the spinner, with inlet and outlet slots as the plans indicate.

Of all the biplanes used in World War I the Roland D-2 is one of the best adapted to control-line use because of its exceptional streamlining and sturdy construction. The latter is due to the fact that the usual cabane struts are replaced by a husky streamlined pylon—which, incidentally, hindered the pilot's forward vision. No dihedral was used, which makes the wings very easy to build, even with the slight amount of sweepback. The model is easy to fly and should bring

back to mind the 1917-18 period when flying machines were assemblies of wood, wire, and fabric.

The fuselage is built up and planked for three reasons: lightness, economy and rapid construction. This type has all these advantages over the hollowed balsa block fuselage. A crutch made from $\frac{1}{4}$ " x $\frac{1}{2}$ " serves as a jig, engine mount and backbone. This is built first and the bellcrank attached securely. Cut out the tail surfaces and trim and sandpaper to shape. Add the fabric hinges and cement the stabilizer to the crutch. Cut out the bulkheads and cement them in place on the crutch. Attach the gas tank and bolt the landing gear in place to the plywood bulkhead. Hook up the control push rod and then cover the whole body with $\frac{1}{16}$ " thick balsa. Strips of about $\frac{3}{8}$ " wide are good for this purpose. Make sure the strips are cemented to each other as well as to the bulkheads. Sandpaper the body until smooth and then cover it with very fine silk. This makes it almost indestructible. Dope it twice and sandpaper smooth. Cut the pylon and cement it in place. Fillet pylon with Aero Gloss plastic balsa. Cut out the cockpit and engine recess, and add vertical tail and strut.

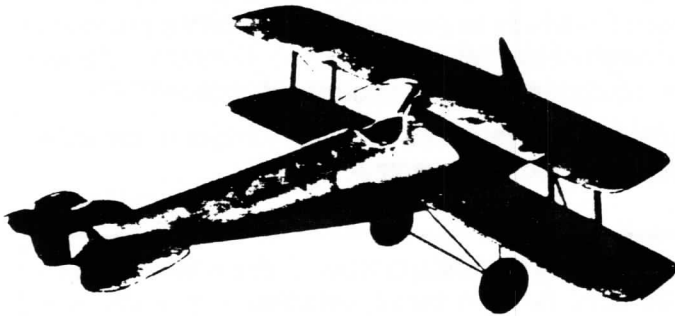

When you make the top wing, extend the right wing leading edge straight through past the center line, as the plans show. This will make a very strong wing. The bottom wing is made in two pieces. Only the root is shown in the plan because the rest is the same as the top wing. A small balsa block is used to fair the wing into the fuselage. Both wings are covered with fine silk. Dope well.

The top wing is cemented in place first. Plenty of cement must be used when doing this. When this is thoroughly dry, the wing struts can be cemented in place. These should be sharpened and pushed into the wing ribs as shown on the plans. Lay the plane on its back and cement the bottom wing panels in place, inserting the

struts in the ribs. Carve the spinner from soft balsa and cement to the propeller, cutting away for the propeller nut and washer.

Once the model has been clear doped three or four times, it is ready to paint. Using Aero Gloss dope the entire model was painted pale yellow three times. The mouth and eyes are black. The upper surface of the top wing is covered with splotches of green and purple. The horizontal tail surfaces and top side of the body are colored in the same manner. All struts are either dark green or purple, and all crosses are black. Of course you can paint the plane any color you wish but be sure to use a paint that is impervious to hot glow plug fuels. It is a good idea to use fuel-proof cement as well. Fine

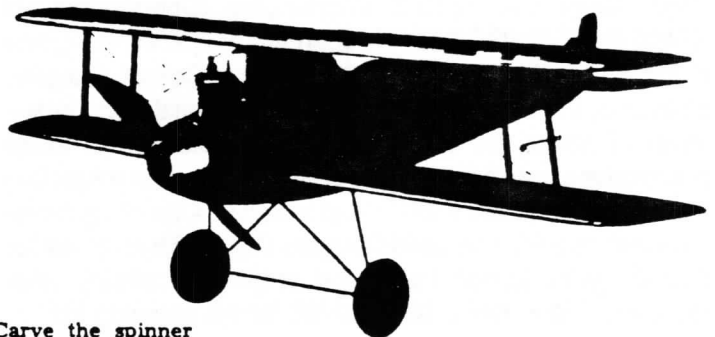

music wire is used for the rigging. This is not necessary but adds quite a bit to the appearance of the model. Machine guns can be made from a hair curler.

The model flies at about 65 mph. I used 50-foot lines for flying, the size of which should be at least .010" dia. A line guide made of wire or plywood should be cemented to the inboard wing strut. Balance the model $\frac{1}{4}$ " forward of the pivot point. Do not fly if the model is tail-heavy or a crack-up will occur. Add lead weight in the tail or nose to balance the model. Be sure to offset the rudder to turn the model away from the center of the circle. This will keep the lines taut.

(Reprinted from the San Diego Aeroneers' *Aeroneers*, Nov '87, Jim Alaback editor)

Return with us now to those thrilling days of yesteryear, when out of the past comes not only the thundering hoofbeats of the great horse Silver, but also the muted whirring of a four-inch machine-cut balsa propeller, driven by a loop of pale yellow rubber. A small scale model airplane is tenderly immersed in its element by the hopeful yet apprehensive builder. Will it fly? Will all of the care and effort that went into its construction and preparation for this maiden flight return the dividend of success? The child who built the model shares--and to no lesser extent--the emotions of vice presidents, chief engineers, and test pilots as they put their "latest and greatest" into the air for the first time for, in his project, he is all three. This experience was once available at an incredibly low price, even when judged by the value standards of the late 1930s.

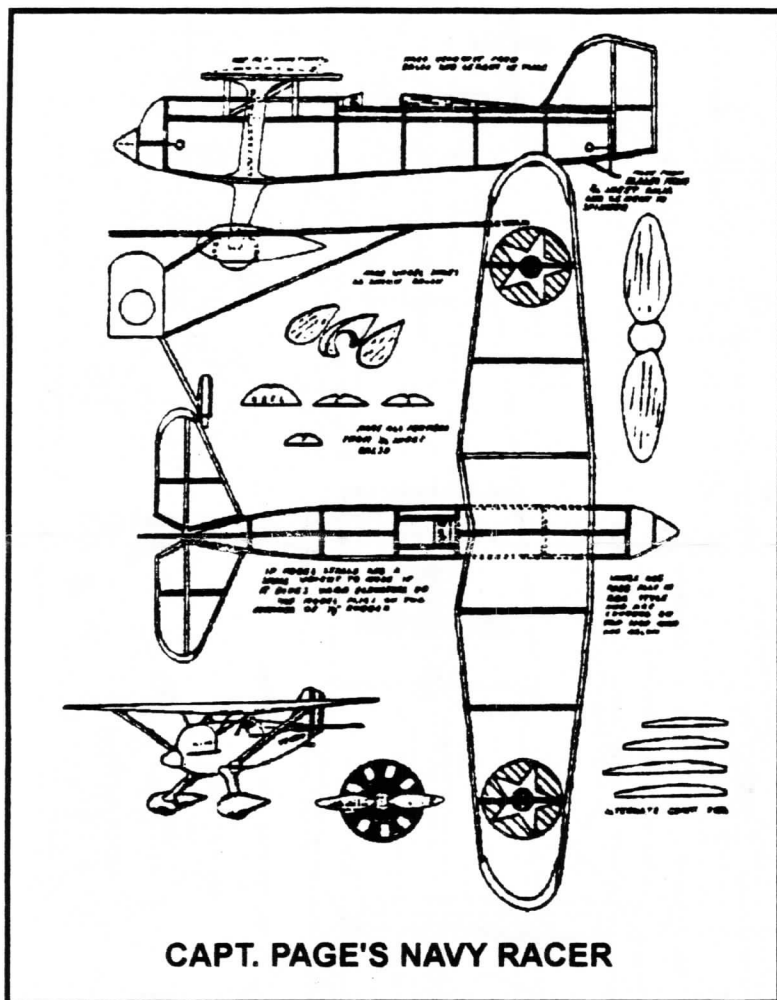

Yes, believe it or not, one thin dime would purchase a flying scale model airplane kit complete to a tube of cement. Selecting, buying, building, and flying these models provided many boys--and some girls, too--with a sense of the value of money, manual dexterity, patience, a knowledge of aerodynamics and structures, the fascination of flight, and the satisfaction of knowing that they could accomplish an involved task. All of this for just ten cents! Is it any wonder, then, that the "airplane nut" who writes these words regards the ten-cent scale model airplane kits of the late '30s and '40s as aviation's greatest bargain? These kits may well have represented the most product for the least cost of any merchandise ever offered.

These scale model kits were generally fairly accurate of line and were very well engineered. Most were good flyers, if reasonably constructed and adjusted. Some were truly outstanding. All were worth whatever effort was required to transform the flat balsa sheet, strips, and Japanese tissue provided in the brightly colored box into a real, three-dimensional airplane.

"Be thankful if you were fortunate enough to have known first-hand the ten-cent model airplane."

About the author: Phil Oestricher started building model airplanes as a boy of seven, in the 1930s, with the ten-cent kits he remembers here. As with so many other youngsters of that era, his on-going model building activities led him to his career. In Phil's case, he went on to earn degrees in Aeronautical Engineering, then into the Marine Corps, and on to become a Naval Aviator, a jet fighter pilot. Upon his return to civilian life, he rose through the Aeronautical Engineering and Flight Department operations of Convair in Fort Worth to become the Director of Flight Test for the F-16 by the time he wrote this nostalgic testimony for the ten-cent kit. Subsequently, the Society of Experimental Test Pilots has presented him with the Ivan C. Kincheloe Award for Outstanding Professional Accomplishment in Flight Testing. Quite a journey to have started with the ten-cent kits that first inspired him some fifty years ago!

PROTECT THOSE KITS!! by Morrie Leventhal

Silverfish delight in eating paper, and mostly plans to that old kit you have, including the covering material, which is the dessert to them.

Both moths and silverfish are repelled by common mothballs and cedar chips. There are several products on the market that are the same as mothballs, such as paradichlorobenzene, naphthalene, and sometimes camphor, but are generally called "mothballs", or moth crystals in super markets and variety stores: Thrifty Drug Stores, K-Mart, Wal-Mart, and Savon drugs, to name a few. If you have cedar wood, like in a cedar chest, saw some to make saw dust, or "chip" some to make chips. This works as well as mothballs.

Put a handful in each kit, or on the shelf or closet where the kits are, and this should eliminate the little holes in the plans and covering material. (Yeah, that's not really age deterioration, but little silverfish having lunch.) Check the mothballs or crystals from time to time, as they evaporate in the air.

Incidentally, during World War II, there was a very fast British fighter/bomber called the "DeHavilland Mosquito". This plane "smoked" with speed for a prop-powered bomber, but, unfortunately was made of wood. The Mosquito was sometimes called the "Wooden Wonder" or "Termites' Delight", and a few other names referring to the wood construction of the plane, which was, believe it or not, balsa sandwiched between Douglas Fir plywood and formed to shape in a steamer. The termites and silverfish ate the glue that bonded the plane together. So, a lesson from aviation history: Mothballs and cedar chips put an end to that, and they can put an end to eaten model plans.

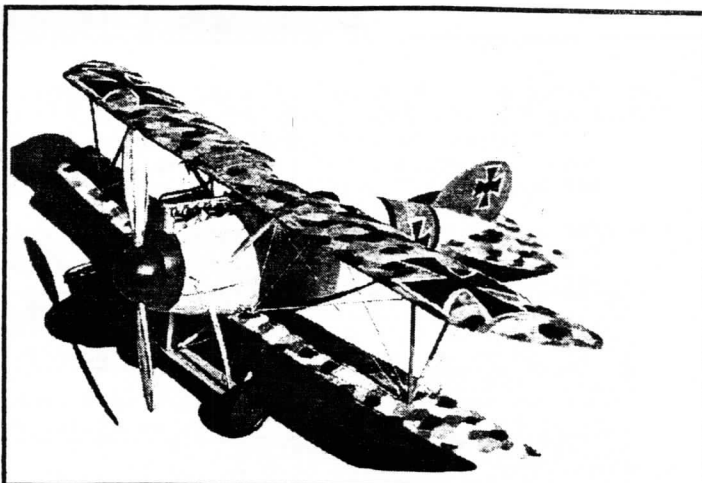

Guillow's (18" w.s.) Albatros D-3, built by Walt Winicki.

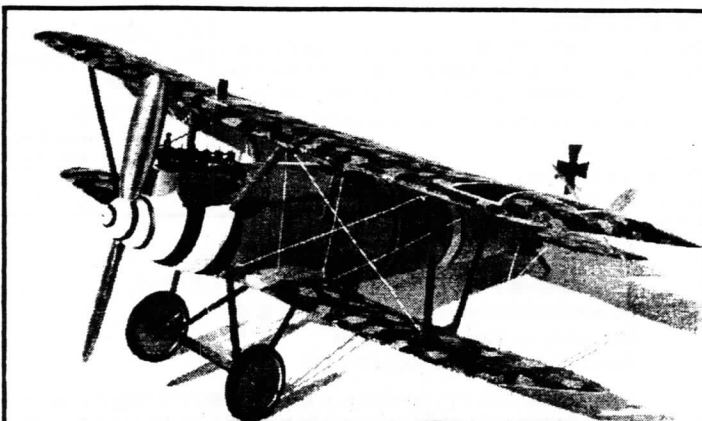

Guillow's (18" w.s.) Pfalz D-3, built by Walt Winicki's son. (Only his 3rd model built!!!)

A neat building tip from John Gascoyne...

Components For Hinging Ailerons, Elevators, & Rudders
(Static replica models – scales about 1/2" thru 2")

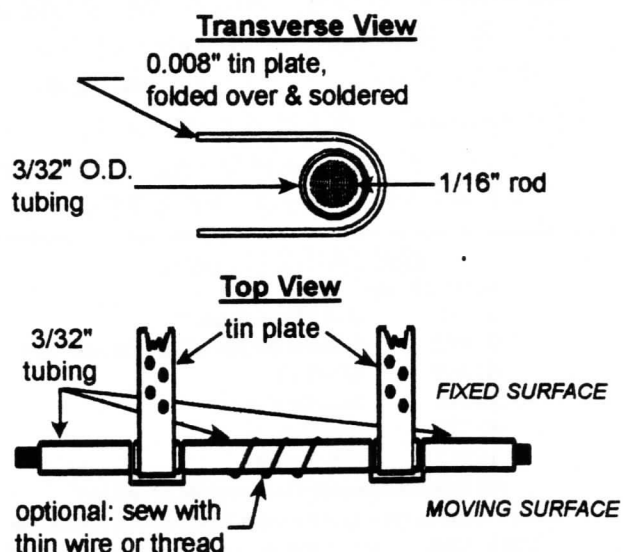

Notice of Aviation and Model Aircraft Auction

Oct 29, 1994 - Ted Maurer Auct., Ridge Firehall, Ridge, PA

- Includes over 1000 old wood model kits from 1920s on, including Megow, Cleveland, Ideal, Miniature, Strombecker, etc.
- Freeflight, rubber, solid, some plastic kits, plans, ignition and glow engines (some rare), accessories, catalogs.
- All model magazines from 1930s on (MAN #1, Flying Aces.)
- Built-up models -- model plane memorabilia

For listing, call 610-323-1573 or write to Maurer Auction, 1003 Brookwood Dr., Pottstown, PA 19464

Collector Classifieds

WALT GRIGG 1303 STETSON ORLANDO, FL 32804:
 -FOR SALE: FLYLINE GREAT LAKES RC KIT.....\$30.00
 SIG (BERKELEY) STINSON L-5.....\$22.00
 Comet Taylorcraft 54", Prewar, G.....\$25.00
 H&F Ryan ST 50", 1946, box water stains \$18.00

- FOR TRADE: BURD KORDA kit, complete, box not orig.
 Joe Ott Airacobra 32" complete, box not orig.
 Comet Monocoupe 32" prewar, box flaps msg, F.
 Megow Stinson 24", #C5, prewar box with racing acct
 Ace Whitman Curtiss Scout Observation 36", prewar,
 #2953. Plans and printwood only..rare goodies.
 Burd Ten-centers, P6E, Fokker D7, VG
 Comet Ten-centers, #A7 Consolidated BT-7, #A9
 Curtiss P6E, both in Keep 'em flying boxes. VG
 Ace Whitman Ten-cent Seversky, 1940. G
 - WANT: TEN CENT, TWENTYFIVE CENT FLYING SCALE KITS,
 FROM THIRTIES, EARLY FORTIES..SOLIDS, TOO..PUNCHOUT
 PAPER PLANES FROM SAME ERA....HAVE ORIGINAL ACE
 WHITMAN PLANS TO TRADE.

JOB HUNTING!!!

Materials Engineer with 20 years experience in Ceramics & Composites. Extensive experience in turbine machinery (coatings, bonding, corrosion & oxidation, glass & glass-ceramics). Will send resume on request.

Joseph E. Palko
 779 Trottingham Drive
 Schenectady, NY 12309-3011

WANTED!!!

Blue Eagle P-30 Square Eagle
 Plans or kit

Joseph E. Palko
 779 Trottingham Drive
 Schenectady, NY 12309-3011

Kits For Sale

- Consolidated Sonic Star U/C - \$15
- Strombecker F-100C Plastic Flying Model Kit - \$15
- Scientific Shoestring R/C (30" w.s.) - \$40
- Goldberg Jr. Skylark R/C - \$50
- Mercury Stinson 105 Gas FF - \$35

L. D. Flores Ph. 714-963-0329 7:00 AM - 3:00 PM (Pacific time)

The KAPA Collector Needs Ace-Whitman Plans!!

- Vultee Valiant •Nieuport 161 •Curtiss SBC-4 Scout

If you have any of these plans (or kits), please contact
 Lou Buffardi
 400 Windward Passage
 Slidell, LA 70458

*LOOK IN OLD MAGS FOR YOUR WANTS; THEN AN
 AD IN KAPA BRINGS RESULTS!*

*WANT: COMET E-10 BELL P-59, T-1 F4E,
 AND M-3 B-29. ALSO DOUGLAS MODELS
 INC. 1/4" B-29B. CLEVELAND TETHER
 STREAK GPL-21. KITS OR PLANS OF
 THE ABOVE BUY OR TRADE: #104
 BRUCE E CONWAY, 3950 MAREBURG,
 CINCINNATI, OHIO 45209*

FOR TRADE OR SALE

- Maircraft solid kits
- (2) H1 IL-2 "Tank Buster"
 - (1) S12 Russian Mosca (slight bx damage)
 - (1) S19 SPAD 13
 - (1) S21 Sopwith Camel
 - (1) S23 Nieuport 17
 - (1) S24 SE5 Pursuit

All kits (except noted) in original condition!

***I am looking for any American Eagle/Porterfield solid
 kits to trade or buy. Monocoupe 90A or 110 also needed***

Bill Cook KAPA #404 8832 Marty Overland Park KS 66212

•JUST LOOK•
 THE MODERN LEANERS WITH NO EQUAL
• MODERNAIR •
 MOST AMAZING GAS-ON MODELS
 THE CLOUD DRIFTER '1.00



Kit?
 PLANS?
 MODEL?

CIRCA
 1940

PARENTS AND MODEL BUILDERS

Get this Gas Model Now for 1MAS FEATURING
THE DICTATOR

By: TRIANGLE MODEL SUPPLY CO. 31 85A 42nd Street, Long Island City, N.Y.

WANTED! DESPERATELY!

I HAVE SEARCHED EVERYWHERE FOR 20 YRS.
 FOR ANYTHING OF THESE TWO MODELS.
 CAN YOU HELP? **BILL SCHMIDT #416**
 4647 KRUEGER, WICHITA, KS 67220 316-744-0378

PH# (814) 462 8447

DENIS J VANORMAN SR
 308 MOSSER ST
 ALTOONA, PA 16602

WANTED:

1. OLD 27 MINZ 2-4 CH R/C systems OR KIT
 FOR AIRCRAFT ONLY. GOOD WORKING COND
2. OLD single channel pulse OR CC systems
3. CG RANGER 30 FF KIT OR plans

R/N Models: Double Kit #CG 502 (SPAD 13C & Fokker D-7), 3/4" scale; and, Double Kit #CG 504 (S.E. 5 & Fokker D-8), 3/4" scale. New. \$20 ea. double kit. Two Sterling Kits, #A-1 (Fokker D-7, 24" w/s), new. \$15 ea. kit. Sterling kit #A-16 (Fokker D-8, 21" w/s), new, \$12. Guillo's Kits #202 (S.E.-5A), #204 (Fokker Dr-1), new, \$12 ea. kit. Guillo's #406 (Focke-Wulf 190), new, \$16. Add \$2 postage for one kit, or \$5 for two or more kits. Will sell all kits, in one lot, for \$110 and I pay the postage.
 John Gascoyne, Rt. 3, Box 284, Appomattox, Virginia 24522. (804) 352-2290

For Sale: 1995 antique model airplane engine calendar. \$10.00
 Allow 8 weeks for delivery.
 Alan Mironer
 269 Concord Road,
 Bedford, MA 01730

COLLECTOR'S C-D PLANS

WORLD'S GREATEST TRUE SCALE PLANS VARIETY
 Since 1919 I am still making my world famous historic Master flying model plans available to all. From 1/32 to 1/4 size for R/C, C/L, F/F, rubber, static. There is nothing else like them anywhere—1400 plans! Real collector's choice items. Ask any old time modeler. Don't shortchange yourself any longer, but send \$2 for the Cleveland-Designed pictorial catalog booklet or get my partially illustrated price list for only \$1. Foreign, add \$1. for Air Mail. None free. Same day service. We have no dealers except at museums.
 Edward T. Packard—Aviation's Best Friend
CLEVELAND MODEL & SUPPLY CO.
 9800AS Detroit, Cleveland, OH 44102

*PLANS. CLASSIC SPEEDBOAT
 PLANS CHRIS CRAFT, CENTURY
 GARWOOD, ALSO OLD HYDROS
 AND GOLD CUP WINNERS.
 WANTED. Old ship & boat
 kits, DUMAS, TERKELY
 ETC. Also plans. GARY
 GRISWOLD 5245 V. MERCER
 WAY MERCER IS, WA. 97040*

WANTED--ANY INFORMATION, ARTICLES,
 PLANS, NOSTALGIA, OR "WHAT HAVE
 YOU", ON THE "JIMMY ALLEN"
 CONTEST PLANES OF THE 1930'S.
 Frederick E. Wadd 749 Teaticket
 Hwy. East Falmouth MA 02536-5645

Collector Classifieds

FOR SALE: I am winnowing my collection of model airplane books and kits, and have the following lists:

1. Flying model kits, 1940s to the present, mostly rubber, but some CO2, RC, etc. 10 page list, \$1.00
2. Solid wood scale models. 1 page list SASE
3. Plastic scale kits, fairly recent. SASE
4. Model airplane books, 1920s to the present. SASE (You can have all 4 lists for \$1.00)

Other items for sale include old Brown Campus B with adaptor for current charger, MEW 601 jet engine, complete run of Cleveland Modelmaking News with plans.

WANTED: flying paper airplane items, premiums, etc.

Road Tweet, 3900 8th Avenue, Rock Island, IL 61201
Tel. (309) 788-6927

WANTED-- Originals or Xerox copies of the following:

Plans for Megow Models "Douglas Observation Plane" in 21 inch long black box with a picture of a Doug. O-43A on the top label.

Plans and insignia for United Airlines Mainliner, Douglas DST, 25 inch span, kit #4 mfg. by Hobby Model Mfg. Co. Inc. NY, USA.

Print wood for Capitol Model Aircraft Co. Curtiss P40 Warhawk, 30 inch span.

Dave Felmley, 329 Iris Dr., Pittsburgh, Pa. 15235 (412) 371-2479

WANTED: GUILLOWS DEHAVILLAND MOSQUITO AND POSSIBLY OTHER WW II KITS.

JOHN KUEHNERT
1863 ROLLING HILLS
NORMAN, OKLAHOMA 73072-6707

ALSO STILL LOOKING FOR PARTS FOR SPEEDDEF-BILT B-17 (SALVAGE OR VAC REPLICA OK)

WANTED WANTED

BERKELEY KIT: AERONCA SEDAN RUBBER KIT
ACE-WHITMAN KIT: #5377 BOUTON-PAUL DEFIANT
MONARCH KIT: SCOT-FREE
COMET KIT: #E9 "HELICOPTER"
PLANS: FOR SCIENTIFIC 6-FT MONOCOUE FROM 1934 (OR KIT, IF AVAILABLE)

MORRIE LEVENTHAL, 1788 NIOBE AVENUE
ANAHEIM, CA 92804, PH. (714) 535-6570

FOR TRADE "ORIGINAL COMET PLANS" OR CAN COPY, CURTISS HAWK P-6E STICK & TISSUE 15 1/2" W.S., ALL FORMERS PRINTED ON PLAN, CUT BUT IN GOOD CONDITION, DATED 1935. COMET GLOSTER GLADIATOR, MID 30'S ERA. 1 1/4" SOLID SCALE 7 1/8" W.S., FROM KIT #1S-204 EXCELLENT CONDITION. COMET 40'S ERA GYPSY JR. (SLOOP) PATTERNS PRINTED ON PLAN BUT MUST BE ENLARGED TO BUILD, EXCELLENT CONDITION. WANTED ORIGINAL PLANS OR GOOD PHOTOCOPIES OF COMET #14 8" W.S. SOLID FAIRCHILD RANGER, COMET #B16 7 1/2" W.S. SOLID BELL PURSUIT, COMET #L6 CURTISS WRIGHT OSPRY 31" W.S. STICK & TISSUE, P.K. GUILLOW 16" W.S. R.O.G. STICK FUSELAGE WITH TISSUE COVERED WING. ALL FROM MID 30'S. ALSO WANTED TO BUY OR TRADE FOR YOUR OLD SCENT, LOCENT, 25 CENT, 50CENT ETC. STICK & TISSUE KITS ANY CONDITION, ANY AMOUNT. PLEASE MAIL ANY SIZE LIST WITH PRICE AND CONDITION WHERE POSSIBLE TO: JOE SHOTTS, SR., 3355 MAYSVILLE PIKE, ZANESVILLE, OHIO 43701 OR CALL 614-453-2219 10AM-LOPM EST. THANK YOU, JOE

WANTED: CARTER CRAFT SCALE WW I SHEETWOOD KITS, MONOGRAM SPEEDEE BILT SPAD. WALLACE TRIPP, 1401 MARENCO AVE. SOUTH PASADENA, CA. 91030

KITS WANTED: Guillow's "WW and 100 series" World War I kits with 18" wing span; "100DC, 50DC, and 25DC kits" or any discontinued Guillow kits; Hawk, Maircraft, or other solid balsa kits; Also interested in Megow, Joe Ott, Comet, Berkeley, Ideal, Cleveland, Ace-Whitman, Air-King, California Models, Sierra Nevada Models, Supreme, Monogram Speedee-Bilts, Sterling, or any other discontinued kits from the past; Newly interested in Hudson Miniatures "Old Timers" wooden car model kits from 1949 (imprinted on box but plans may indicate 1950's). Builder/Collector will pay top prices. George Santikian, 7285 N. Channing Ave., Fresno, CA 93711. (209) 439-3363. All sale/trade lists welcome and thank you KAPA members for your fair dealings and assistance with this exciting hobby!

Cleveland Hawk P6-E SF-21B, P&P \$25. Lincoln Sport SF-36, P,P&strip \$20. Goshawk D-49, P&P \$20. Laird Solution & Super Solution SF-5B & SF-46, plans & Ozalid copies of printwood, \$15 for both. Hawk P-6E SF-21 plans only (aged) \$10. Megow French Caudron C-460 Racer blueprint \$15. Buzzer Model Co. Buzzer'd Bombshell for CO2 P&P \$10. Consolidated Aero Puppet U-Control \$50. Supreme Sportsman B Pylon FF \$75. Flyline Bellanca Skyrocket \$20. Inland Sport \$25. Herb Cluckey J-3 \$45. Hunt 1933 Longster \$30. Golden Age Douglas Y10-43 \$25. Jim Walker Whip-Power \$25. Renwall "The Visible Aircraft Engine plastic 1/4 scale P&W Wasp (still in plastic wrap) \$75. Herkimer Dramaster CO2 w/engine NIB \$100.

 **Thomas C Cope** Please add for shipping
23262 SE 57th St
Issaquah WA 98027 telephone: (206) 392-2590

"Snitter"

Plans for original Midwest kit # FG-1
Glide Angle 7-1 .010-.049 Wingspan 29 1/2"
Overall Length 20 in. Wing Area 135 Sq. In.
Complete plan set, includes fuselage and L/G templates, materials list. Shipped rolled in mailing tube. \$7.95 Ppd. in U.S.A.
Charles Reich 4165 Riverbanks Road Grants Pass, OR. 97527

TRADING: STICK & TISSUE KITS BY CLEVELAND-COMET-GUILLOW-MINIATURE AIRCRAFT CORP.-MEGOW & WHITMAN FOR SOLID A/C KITS. LIST WHAT YOU HAVE AND WHAT YOU ARE LOOKING FOR WHEN INQUIRING. ED MARCINIEC, 25 LORI ST., SPOTSWOOD, N.J. 08884

WANTED
TELCO CO2 TURBOTANKS

MODEL-3000 MODEL-6000
PURCHASE-TRADE

C.P. CHAPMAN 1-312-235-2697
2628 N. CENTRAL PARK
CHGO, ILL. 60647

FOR SALE: Last of the Gordon Model Airplane Co. plans for the Curtiss Swift, \$4.00+.75c postage @. Original 1960 LOCKHEED Coloring Book, \$10.+\$2. postage.

WANTED: Ercoupe kits or plans & printwood patterns for them, especially the CAVACRAFT U/C and COMET Struct-O-Speed kits. **KITS FOR SALE OR TRADE:** Send SASE for copy of list. Also want land to build home in NW Washington State or Olympic Pen. Will pay cash or trade land in Gatlinburg, TN (Smoky Mtns) or outside San Antonio, TX. Lou Buffardi, 400 Windward Passage, Slidell, LA. 70458

Kits and Plans Antiquitous

Kits and Plans Antiquitous (KAPA) is a club for modelers who enjoy collecting, preserving, restoring, and exchanging wood model airplane kits and plans that are no longer available, as well as learning more about the companies and people who originally created them, or who are recreating them today.

KAPA membership includes the next four issues of the club's quarterly newsletter, the *KAPA Collector*, which is published in June, September, December, and March. The *Collector* includes news of the club, historical information, how-to-do-it articles, plans and photos, and classified advertising.

Advertising in the *KAPA Collector* is free to members. Send advertising (typed or neatly lettered in block letters, using black ink) on a 3 x 5 file card or a postcard to the editor, Louis N. Buffardi, 400 Windward Passage, Slidell, LA 70458. Each advertisement will be run for one issue. If the same advertisement is to be run again, it should be resubmitted. Advertising or editorial material must reach Lou Buffardi by the 15th of the preceding month for each issue: February 15, May 15, August 15, or November 15.

In advertising or describing items for sale or trade, club members should fully describe the condition of items offered. Describe any kit box wear, damage, or repairs and any known parts missing or not original. Plans should be stated to be originals, photocopies, blue-line prints, etc.. If shipping charges are extra, they should be specified.

Members' stories and articles are solicited for publication in the *Collector*. If possible, the text should be typewritten, single-spaced, 10 CPI, with 1" margins. Illustrations such as plans or advertisements that relate to the article are desirable, too. See articles already published in the *Collector* for guidance on content and style, or send an SASE to the editor for a "Writer's Guide" of suggestions and guidance.

Membership dues are \$6 per year in the US (\$8 in Canada and Mexico, \$11 via air mail in other countries, with payment in US Dollar-denominated funds). Make checks or money orders payable to "KAPA". Send membership applications to KAPA Secretary-Treasurer Morris E. Leventhal, 1788 Niobe Ave., Anaheim, CA 92804.

Collector back issues from Vol. , No.1 (March '93) onward are available at the postpaid price of \$2 each in the US (\$2.50 in Canada and Mexico, \$3.25 via air mail in other countries--payment in US Dollar-denominated funds). Send orders to Jim Alaback, 12366 Nacido Drive, San Diego, CA 92128-3108.

Notify Morris E. Leventhal, 1788 Niobe Ave., Anaheim, CA 92804 of any change of address!!



Morris E. Leventhal
1788 Niobe Ave.
Anaheim, CA 92804

To:

100-F 6/95
Claude H. Powell
P.O. Box 454
Ridge
MD 20680

FIRST CLASS MAIL

