

JUNE
1944

AEROMODELLER 1/-

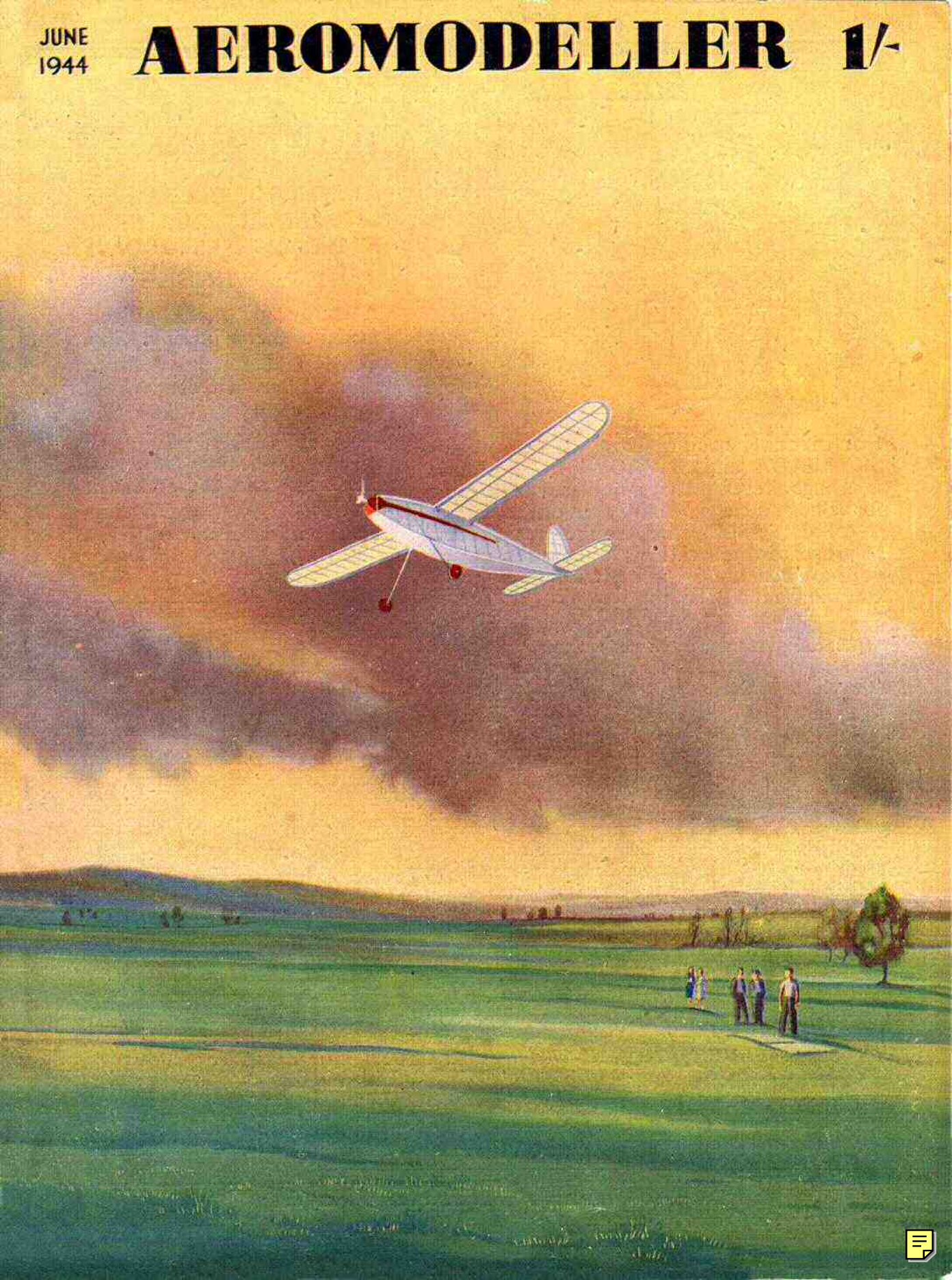

Build this 1'-1" FLYING SCALE MODEL "KIRBY CADET" GLIDER

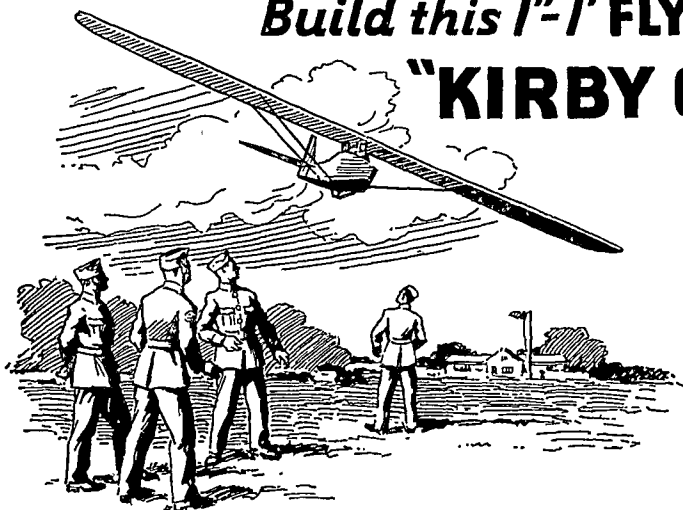

**A REPLICA OF THE MACHINE
USED FOR GLIDER TRAINING
BY THE AIR TRAINING CORPS**

38-ins. WINGSPAN

A sturdy and excellent flying model of the well-tried "Kirby Cadet." Simple to construct, easy to fly. Kit contains all necessary Balsa and Balsa-sub. strips, printed sheets for all ribs, formers, bulkheads, seat, etc., large tubes Balsa Cement and Tissue Cement, covering tissue, and detailed full-size drawing

7/6

For aircraft recognition the demand for SKYLEADA and SKYROVA Solid Models is as huge as ever. They are still second to none for value and being definitely out of the class of so-called "Solids" which require nothing short of a hacksaw and chopper to construct, when you have built one SKYLEADA or SKYROVA you will want a Squadron !

SKYLEADA Spitfire, Martlet, Hurribomber, } 1/9
(1/72 Scale) Kittyhawk, Thunderbolt, Mustang }

Lightning, Whirlwind, } 3/- Hudson, Boston, } 3/9
Mosquito, Beaufighter } Airacuda, Ju-88 }

SKYROVA York Stirling } 3/-
(8-9 in. Span) Fortress Lancaster }

Illustrated here is the latest book on Solid Model construction which will amply repay its modest cost of 2/6, and the "Pilot" Plan Pack of nine 1/72nd scale plans at 1/-

9

**World-Famous Warplane
CONSTRUCTION PLANS**

CONTENTS:

SPITFIRE
M.E. 109F
DEFIANT
MUSTANG
MARTLET I.
AIRACOBRA
KITTYHAWK
HURRIBOMBER
THUNDERBOLT

Complete with Instructions.

FROM THE

PILOT

SOLID SCALE SERIES

• 1/-

ACCURATE PLANS MEAN
ACCURATE MODELS.



Separate Plans at 4d. each also available of LIBERATOR, HUDSON, BEAUFIGHTER, JU-88K, WELLINGTON, ME-110, BOSTON, MANCHESTER, MOSQUITO

The above plans as well as the Solid Model Aircraft book should be obtainable from your local dealer. Kits may be in short supply, however, but orders from A.T.C. and Service personnel endorsed by C.O. or Unit through your local dealer receive priority

**A. HUNT
(CROYDON) LTD
5&7 SOUTH END
CROYDON**

Superb Solids by

C.M.A.

**SUPER KITS OF THE
TYPHOON and
THUNDERBOLT**
for the
"PUKKA" MODELLER

All good things are worth waiting for—but you need wait no longer.

**CALL & SEE YOUR
DEALER TO-DAY**

MESSERSCHMITT ME 109F 5/3

BRISTOL BLENNHEIM 6/11

WESTLAND LYSANDER 6/4

FAIRLEY BATTLE 5/6

DOUGLAS BOSTON 8/3

HAWKER HURRICANE 5/3

SUPERMARINE SPITFIRE 5/5

BOULTON & PAUL DEFiant 6/9

BEAUFIGHTER 7/11

WESTLAND WHIRLWIND 6/6

SCALE 4"=1'

FOKKER WULF FW 190 A3 6/4

JAPANESE COO 12/12

LOCKHEED P38 8/9

BELL AIRACORRA 6/3

BLACKBURN SKUA 6/7

MESSERSCHMITT ME110 6/11

D. H. MOSQUITO 7/6

WHOLESALE ONLY

OWING TO THE SHORT-AGE OF SUPPLIES WE ARE NOT ABLE AT THIS TIME TO OPEN ANY NEW ACCOUNTS

List of model kits not illustrated

D. H. Tiger Moth.....	4/11
S.E. 5	4/11
Pfalz D. 12	4/11
Morane Saulnier 406.....	5/3
Bristol Fighter F.2b.....	5/3
Russian Rata L.16.....	5/3
Polish P.Z.L.P.24.....	5/3
D. H. Dragonfly.....	5/6
Caproni Falcho	6/-
Curtiss P.37	6/3
Brewster Buffalo.....	6/9
Typhoon	6/9
Thunderbolt	6/9
Fokker G.I.....	8/11

ILLUSTRATIONS ARE PHOTOS OF ACTUAL MODELS MADE FROM C.M.A. KITS.



**CHINGFORD MODEL
AERODROME LIMITED**
155, STATION RD. LONDON, E.4



ELITE MODELS

14, BURY NEW ROAD

MANCHESTER, 8

GLIDER No. 1

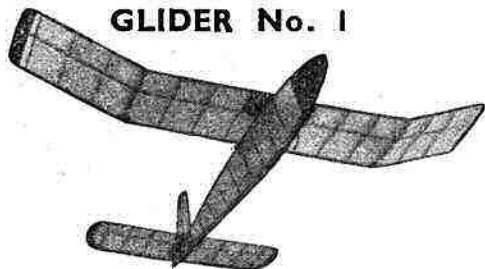

30 Inch span

COMPLETE KIT 6/6 Post Free.

Contents of Kit :— CUT-OUT RIBS, DOPE, CEMENT, TISSUE STRIP, ETC., and FULL-SIZE PLAN.

A simple Model of original design, based on the best glider principles. Not a rehashed version of a rubber-powered machine.

GLIDER No. 3

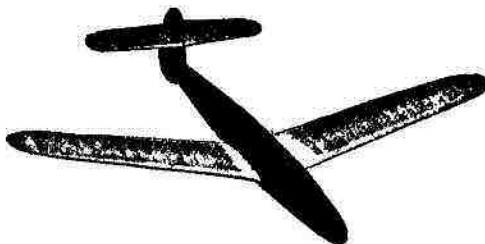

45 Inch span

FULL SIZE PLAN and CUT-OUT RIBS
5/6 Post free

GLIDER No. 2

36 inch span

COMPLETE KIT 9/1 Post free

THE "GNAT" 16" GLIDER

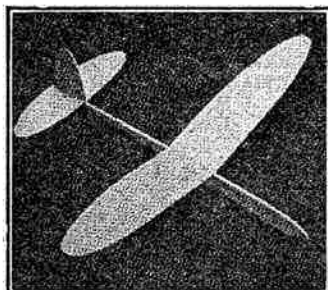

Kit contains Plan, Ribs and Sheet, Cement, etc.
2/6 Post Free.

LIMITATION OF SUPPLIES ORDER

We regret, owing to the above order, we cannot supply our Glider No. 2 or Airborne Kits to other than the following :—
H.M. Forces, A.T.C., J.T.C., Sea Cadets, The Royal Observer Corps and Spotters' Club affiliated with the National Association of Spotters' Clubs.

All orders must be signed by the Commanding Officer or appropriate officer.

ELITE SOLID KITS SERIES 1/72 SCALE

Supermarine Spitfire V8	North American 73
Supermarine Spitfire VB (Clipped Wing)	Mustang I
Hawker Hurricane II C	Republic Thunderbolt
Hawker Typhoon I B	Messerschmitt ME109 FI.
Curtiss Warhawk	Focke-Wulf Fw. 109 A3
	Macchi C 202 (Saetta II)
	Zero
	Kit 2/3 Post free

Mitchell Solid Kit
6/6 Post free

Marauder Kit
6/6 Post free

SOLID KIT OF AIR SPEED HORSA
Now obtainable

MOSQUITO SOLID 1/72 KIT 3/9 Post free.

Cockpit Covers

SPITFIRE	6s.
H. HURRICANE	6d.
WHIRLWIND	7d.
WELLINGTON	1/10
MOSQUITO	1/6
LYSANDER, etc.	1/-
FORTRESS II	3/-
THUNDERBOLT	8d.
LANCASTER	3/-

ELITE "AIRBORNE" GLIDER

Just the Model "YOU" want

Span 42 ins. Contents of Kits:—Dopes, Cement, Tissue, Strip Wire, Sheet, CUT-OUT RIBS & Full-size Plan
11/1 Post Free.

We stock only H.M.G. [H. Marcel Guest Ltd.] crystal clear cockpit Covers.

Send 3d. for Catalogue. Fully Illustrated.

ALL ACCESSORIES STOCKED, INCLUDING Balsa SUBSTITUTE, CEMENT, DOPES, FINISHED PROPS, ETC., ETC.

ELITE MODEL AIRPLANE SUPPLIES

14, Bury New Road, Manchester 8.

Kindly mention THE AERO MODELLER when replying to advertisers.

'TRUSCALE'

1/72 Solid Model Kits

ROYAL AIR FORCE

AMERICAN AIR FORCE

and GERMAN WAR PLANES

Messerschmitt 110
Price 2/6

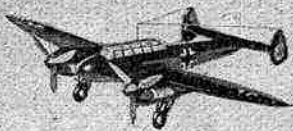

Westland Lysander
Price 2/6



Handley Page Hampden
Price 3/1



Blenheim
Price 2/6



Boulton Paul Defiant
Price 1/10



LATEST MODELS

TYPHOON	...	Price 2/-
THUNDERBOLT	...	Price 2/-
FOCKE WULF 190	...	Price 2/-
MOSQUITO	...	Price 2/6

ALL KITS contain fuselage cut to outline shape, wings cut to shape, tail-plane, rudder, and where necessary nacelles printed on balsa, hardwood cowls and wheels, metal propellers, transfer insignia, cement. Also full-size detailed plan.

Spitfire Price 1/10



Hawker Hurricane
Price 1/10



Messerschmitt 109
Price 1/10

Tomahawk
Price 1/10



Heinkel H.E.IIIK
Price 3/1

SUNDRIES

2" 3 Bladed Propellers	...	2½d. each
1½" 3 " " "	...	2d. "
2" 2 " " "	...	2d. "
¾" Cowls	...	1d. "
⅜" and ¼" Wheels	...	1d. pair

NATIONAL AEROPLANE MARKINGS

R.A.F. (with lettering and numbers)	4d. set
American	3d. "
German	3d. "

Whirlwind
Price 2/6

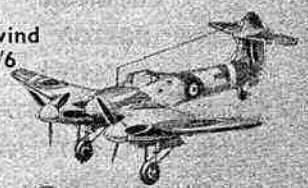

Buffalo Price 1/10

Avro Anson
Price 2/6

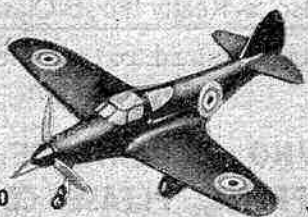
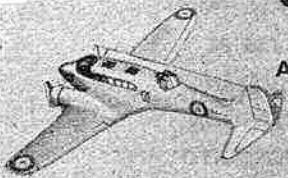

Airacobra Price 1/10



Wellington Price 3/6

MODEL AIRCRAFT STORES (Bournemouth) LTD.

127b HANKINSON ROAD, BOURNEMOUTH

ADD. 3d. Postage on all Kit Prices.

Phone: 1922 WINTON

ADD 2½d. Postage on all Sundry Prices.

UNBEATABLE FOR REALISM



HAWKER "TYPHOON"

Kit absolutely complete, includes all parts cut to shape, turned spinner and wheels, full scale detail plan and instruction sheet, three bottles coloured dope, transfer insignias, celluloid, 2 sheets sandpaper, tube of cement, etc.

FULL RANGE TRANSFER INSIGNIAS, INCLUDING BEAUTIFULLY COLOURED SQUADRON MARKINGS.
SET OF TEN, 6d.

Cement, clear and coloured dopes, wire, cowls, spinners, and every accessory for the Aero Modellerist.

SPEND YOUR QUOTA WITH US.

BUILD A FIGHTER !!

OUR RANGE OF $\frac{1}{4}$ IN. TO 1 FT. SOLID SCALE FIGHTERS ARE SENSATIONAL BOTH IN VALUE AND APPEARANCE.

New additions to our range are the TYPHOON, MUSTANG, and HURRICANE IIb.

Others are: — TOMAHAWK, AIRACOBRA, DEFIANT, SPITFIRE and MESSERSCHMITT 109.

COMPLETE **4/6** 6d. Postage

ALL ENQUIRIES MUST HAVE S.A.E.

MODEL AERO SUPPLIES WEST PARADE WORKS



HALIFAX
YORKS.

Phone:
HFX. 2729

KITS OF DISTINCTION

UP, "PUP," UP! "THE CRUISER PUP"

THOUSANDS SUCCESSFULLY BUILT AND FLOWN!

THRILLING FLIGHTS

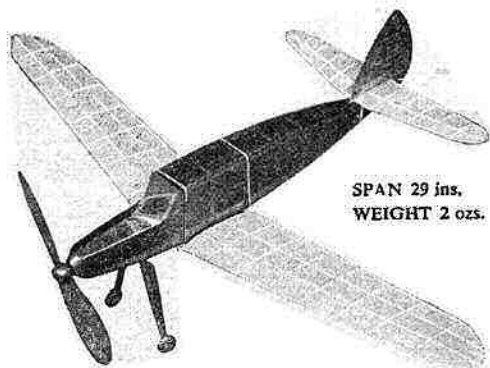

SPAN 29 ins.
WEIGHT 2 ozs.

G.A.H., R.A.F., Pendine, Cornwall

WRITES:

"I have built a 'Cruiser Pup' entirely of your Balsawood Substitute (except for nose block) and would like to express my satisfaction.

The performance of the model is really good and its ability to withstand hard knocks without ill effect is truly amazing!

The small additional weight of P.S.S. (Balsawood Substitute) as compared with Balsawood is more than worth while, as it gives real STRENGTH OF STRUCTURE."

COMPLETE SET
OF MATERIALS
(Including Rubber Motor)

7/6

Carriage Paid
United Kingdom

SEND FOR LATEST LIST 6d. POST PAID

PREMIER AEROMODEL SUPPLIES LTD.

2a, HORNSEY RISE, LONDON, N.19

Phone: ARC 2376

PLANES THAT PLEASE

Kindly mention THE AEROMODELLER when replying to advertisers.

NORTHERN MODEL AIRCRAFT CO.

25, Lower Mosley Street, Manchester 2

Phone: CENTRAL 1804

NOW READY ALBEMARLE Kit, containing plan, cut-out wood parts, powder paint, wheels. Price 4/- 1/72nd scale. MOSQUITO, WHIRLWIND and TYPHOON plan and cut-out wood only.

IN PREPARATION 1/72nd BARRACUDA Kit, blue prints, large range to 1/48th scale. Cows in 1/48th scale, ALBEMARLE, BARRACUDA and other kits in 1/48th scale. Spinners and prop blades. Our range of 1/48th blue prints will include FOUR ENGINED BOMBER types, FLYING BOATS, etc. Plans to 1/48th scale (line drawings) for SPITFIRE, TYPHOON, MUSTANG, TOMAHAWK, THUNDERBOLT, Ju. 87, MOSQUITO, BLENHEIM IV and MARAUDER. Prices: Fighter plans 1/3 Bomber 1/6

ACCESSORIES FOUR types of COWLS, 2d. each. COWLS with ENGINES, 6d. each. 14 cyl. Radial Engine and Cowl suitable for ALBEMARLE, etc. CAMOUFLAGE DOPES with brush, 1/2 WHEELS, 2 for 1 1/2d., 1d. each and 2 for 2 1/2d., tissue paste with brush 1/2 COCKPIT COVERS to 1/48th scale for SPITFIRE, TYPHOON, LYSANDER, DEFIANT, HURRICANE, ME. 109, MOSQUITO, BLENHEIM, AIRACOBRA, WHIRLWIND.

KITS BY ALL LEADING MANUFACTURERS

C.M.A. * TRUSCALE * SKYLEADA * SILVERWINGS * ASTRAL * ETC.
Catalogue 4d. post free.

SPECIAL NOTICE

Before sending your order you are advised to try your local dealer for any of our accessories and kits. These are now obtainable at most Model Aircraft dealers

SLICK

MODEL AIRCRAFT PRODUCTS

A First-Class Material—For a First-Class Job

Approved by all the Leading Model Constructors.

LATEST SELLING PRICES

Manufacturers to the Trade only.

BALSA WOOD CEMENT (both ordinary and field drying), in 5d. and 8d. size tubes.
COLOURED DOPES (for wings and fuselage, 7 shades), in small sizes 8d. 1/2 pint tins 4/- each.
CAMOUFLAGE DOPES (Brown and Green) in small size 8d. 1/2 pint tins 4/- each.
CLEAR FABRIC DOPE (for wings, has extraordinary tightening properties), in small size 8d. 1/2 pint tins 4/- each.

THOROUGHLY TESTED

HIGHLY RECOMMENDED

Manufactured by:—



AS SUPPLIED TO: R.A.F.—A.T.C. & ALL TRAINING SCHOOLS, A.A. BATTERIES—R.O.C., ETC., ETC.

SPECIAL QUOTATIONS TO BULK BUYERS, also MANUFACTURERS OF SMALL SIZES FOR USE IN KIT PACKS.

Write and ask for full particulars and best Export terms

Liberal discount to the Trade.

BANANA OIL No. 1, Thick.
BANANA OIL No. 2, Thin, in small size 8d. 1/2 pint tins 4/- each.
BALSA PLASTIC WOOD, in 8d. size tubes.
SPECIAL TISSUE PASTE, in 4d. size tubes.



MODEL AIRCRAFT TRADE ASSOCIATION

SLICK BRANDS LTD., Waddon, Croydon, SURREY

Phone: CROYDON 3171-3172

Please note that this announcement is addressed to the Trade ONLY and private individuals cannot be supplied direct, but SHOULD DEAL THROUGH THEIR LOCAL RETAILERS.

Telegrams: "SLICKBRA" LONDON.

Kindly mention THE AEROMODELLER when replying to advertisers.

ASTRAL

Aero
Model Co.

JOHNNY'S GOT A
"ZERO"



AND HE'S ALSO
GOT A

"JET"



*An imaginative conception
of a Jet-Propelled Monoplane
of the future, based on the
FLIGHT drawing, with grateful
acknowledgments.*

ASTRAL ALWAYS LEAD

Trade enquiries to: Astral Mills, Dixon Lane
Road, Leeds, 12. 'Phone: 37021 (3-lines)

**ASTRAL KITS ARE THE
CEILING**



AEROMODELLER

(INCORPORATING "THE MODEL AEROPLANE CONSTRUCTOR")

The Model Aeronautical Journal of the British Empire

Established 1936

VOL. IX No. 103

JUNE 25th, 1944

PROPRIETORS:
MODEL AERONAUTICAL
PRESS, LIMITED

Managing Editor:
D. A. RUSSELL, *M.A. Mech.E.*

Editor
C. S. RUSHBROOKE

SUBSCRIPTIONS:
INC. CHRISTMAS
DOUBLE NUMBER
15/- P.A. PREPAID.

ALLEN HOUSE
NEWARKE STREET
LEICESTER
Tel: LEICESTER 65322

Forward from Yesterday

WE know, and the evidence comes to us almost daily from aeromodellers in all parts of the country—even in the Forces—that there has for a long time been a feeling that something is lacking in the organisation so far available to those who have the hobby at heart.

The Society of Model Aeronautical Engineers has without doubt done good work in the past and will probably continue to do so in the future, but times have changed, and changed very rapidly in recent years. Occasions have arisen in the past when swift action has been necessary and when it would have been greatly in the interests of all aeromodellers if a swift and proper approach could have been made to the Government on matters of vital importance. When the Board of Trade, by a flick of the pen, included model aircraft kits and accessories in the Limitation of Supplies (Miscellaneous) (No. 21) Order—thereby classifying them with "toys"—the S.M.A.E. failed to raise its voice in protest or offer to come to the aid of the Model Aircraft Trade Association in its lone efforts to rectify the blunder on the part of a Civil Servant entirely unversed in, and unaware of, the vast difference between a toy and something of scientific and educational value and national importance.

Despite protests, the S.M.A.E. has continued to confine its attention almost entirely to the Club movement—eminently desirable, it has to be acknowledged, but nothing like representative of the aeromodelling movement in this country as a whole.

In spite of considerable pressure from the more business-like of its members, and financial encouragement by the offer from this journal of 100 guineas, and the offer of a donation from the Model Aircraft Trade Association of £200, the S.M.A.E. has persisted in refusing to step-up its rate of subscriptions and organise its finances on a more business-like basis and to employ a full time secretary and have offices of its own.

These points have all been voiced so often and so loudly inside and outside the conference rooms of the Society, that the music has become monotonous, and the fact that *nothing has been done* to rectify these errors and omissions has obviously influenced the many tens of thousands outside the organisation against joining the few thousand odd who are inside it.

No one can say, therefore, that the formation of the Association of British Aeromodellers is not a fine, healthy and happy augury, and something that the aeromodellers in this country have long been needing and, in fact, clamouring for.

With the birth of this new organisation we feel justified, having considered the aims, objects, rules and regulations of the Association, in giving it our full support. It is our belief that in the near future there will be built up an organisation representative of the great body of aeromodellers in this country, and that from now

onwards their united interests will be catered for properly.

We wish to make clear the policy of the AEROMODELLER in regard to the S.M.A.E. We see no cause for any idea to arise in the minds of aeromodellers that the new Association is to be in competition with the older organisation, less still that it has been formed with a view to putting the latter "out of business." As we understand it, the Association of British Aeromodellers has been formed with a view to doing what the S.M.A.E. has failed to do; that is, provide an organisation sufficiently well financed, and with a sufficiently wide outlook, to cater for the needs, care for, and if necessary, protect, the interests of aeromodellers in this country.

Elsewhere in this issue we publish a preliminary announcement on behalf of the A.B.A., from which it will be seen that there are nine distinct sections provided for, and that each section will have its duly accredited representative on the Council. Provision is made for several more members of the Council being elected from the general body of aeromodellers, who may do this by card ballot—what the S.M.A.E. has been urged to institute—but again has failed to do.

In our Club section we publish a list of Founder Members, and their donations, together with a first list of Trade donations; from which it will be seen that already—in fact, prior to any real public announcement—the Association has been placed in possession of considerable funds. These include the 100 guineas which were offered by this Journal, and substantial support promised by the Model Aircraft Trade Association, *provided* a full-time secretary was employed and an office organisation set up.

We understand that the selection of a full-time secretary will be made within two or three weeks, and by the time this issue is published office accommodation should have been found in the centre of London; but, with a view to starting off "in top gear" a temporary secretary and office accommodation were found immediately, and have been in use from the time of the inaugural meeting of the Association, held on May 7th.

It may be noted that membership of A.B.A. is open to any person of any nationality, and there is no reason why members of the S.M.A.E. should not join A.B.A., retaining their membership of the older Society, if they wish to do so.

We feel sure that aeromodellers will consider carefully the implications behind the inauguration of this Association, and realise the truth in the old tag, "Unity is Strength," and that the measure of success achieved by the Association will be in strict proportion to the support afforded to it. Those who prefer to "sit on the fence and see what happens" cannot expect to receive much . . . those who believe that the Association should, can, and, in fact, *will* be a success, are the

members to whom the Association will be of greatest value in return for their early support.

Donations to the main funds of the Association will of course be welcome, and will all be acknowledged in subsequent issues of this journal.

As we go to press we learnt from the temporary

Secretary of the Association of British Aeromodellers that Sir Robert Bird, Bart., M.P., has accepted the Presidency of the Association. We hear also that West End offices have been arranged and will be opened within the next two or three weeks.

D. A. R.

‘Impudence, Ignorance or Imprudence?’

THE position in regard to the so-called “ban” on the flying of petrol engine driven model aircraft and model sailplanes has become so involved by the recent premature issue by the S.M.A.E. of a “Special Edition” of the “S.M.A.E. News,” that we felt bound, as a matter of public interest, to make an investigation into the whole matter; and now set out in the following report, without fear or favour, a series of FACTS . . . from which readers may draw their own conclusions!

1. On July 20th, 1940, the Air Ministry addressed a communication to the Royal Aero Club regarding a report received by the Metropolitan Police that a model aircraft with a wing span of 9 ft., belonging to a member of the Croydon Model Flying Club, had landed on Addington Golf Course.
2. The Secretary of the Royal Aero Club sent a copy of this letter to the Secretary of the S.M.A.E., who replied direct to the Air Ministry on July 29th, 1940, suggesting that:—
 - (a) the flying of petrol engine driven model aircraft be prohibited, and
 - (b) the flying of elastic driven model aircraft and gliders exceeding 5 ft. in wing span should also be prohibited.
3. The Air Ministry replied to the Secretary of the S.M.A.E. under date of August 3rd, 1940, to the effect that the Air Council agreed with the first part of the proposal, regarding the flying of petrol engine driven model aircraft; but they considered that it would be sufficient if the prohibition regarding flying of elastic driven model aircraft and gliders was confined to those with a wing span exceeding 7 ft.
4. Following this correspondence, the S.M.A.E. had printed a small green card, which was issued to Clubs affiliated to the Society. This card did not bear any date of issue, and referred to “An Air Ministry *ORDER of August 3rd, 1940,” and then proceeded to set out the two prohibitions as suggested by the Air Council.

**(It may be noted in passing that this letter from the Air Council WAS NOT an Air Ministry Order, but merely set out the agreement by the Air Council to suggestions made by the S.M.A.E.)*

(As a point of interest, there was a ban on the flying of gliders instituted at the beginning of the war, under one of the Air Navigation Acts; but, as noted above, the

Air Ministry thought that there would be no harm in the flying of gliders of a span less than 7 ft.)

The question of the Air Ministry being invited to revise its ideas and agree to the flying of petrol engine driven model aircraft and model gliders was first raised by the Managing Editor of this Journal, Mr. D. A. Russell, at the S.M.A.E. A.G.M. held on the 14th February, 1943. At the A.G.M. held on the 20th February, 1944, no report on this matter was submitted by the officers of the Society, and Mr. Russell drew attention to the fact that the Secretary’s report, when read out for confirmation by the present meeting, made no reference to his having raised the matter at the previous A.G.M. The Secretary expressed his regret for this omission, and when asked what steps, if any, had been taken in the preceding year, to raise the matter with the Air Ministry, he replied that in the autumn of 1943 he had had a conversation with an Air Ministry official, which had not been productive of any result. Considerable dissatisfaction was expressed at the 1944 A.G.M. at this state of affairs, and a resolution was passed that a new approach should be made to the Air Council.

It appears that in the past few weeks an approach has been made to the Air Council, but we are unable to describe the exact form of it, owing to the unwillingness of the S.M.A.E. to provide this Journal with the necessary information. We are pleased, however, to record the reply from the Air Ministry, by the kindness of the Secretary of the Royal Aero Club, to whom the letter was addressed. We have been given a sight of this letter, which is dated 10th May, 1944 and reads as follows:—

“I am to inform you that the Council have decided that flying of these types of model aircraft may now be resumed in areas north of a line Southwold, Bury St. Edmunds, Bedford, Gloucester and Bristol Channel, subject to the following conditions:—

- (a) flying is to be carried out only by members of Model Aircraft Clubs affiliated to the Society of Model Aeronautical Engineers;
- (b) there is to be no flying between the hours of sunset and sunrise;
- (c) there is to be no flying in official prohibited areas, or within 2 miles of any R.A.F. Station;
- (d) models are to be set to fly in a closed circuit only;
- (e) wing span in all cases is not to exceed 10 ft.;
- (f) maximum engine running time is to be 45 seconds (to be controlled by a mechanical device approved by the S.M.A.E.);

CONTENTS OF THIS ISSUE

Editorial	331
A Foelproof Stripper. By Gordon Allen	335
1/32 Scale Brewster Buffalo. By J. A. F. Halls	336
The Calculation of Downwash over a Stabiliser. By J. K. Robinson, B.Sc.(Eng.)	338
1/48th Solid Scale Model Motors. Article V. By “S. B. S.”	340
Hardwoods. By R. S. Welford	341
The Blackburn Bluebird IV. By E. J. Riding	342
A 1/72nd Solid Scale Beaufighter. By P. O’Keeffe	345
Electric Motor for 1/72 Scale In-line Engine Aircraft. By F. Dudley	350

G.H.20. By G. W. W. Harris	352
Make and Mend. By Gordon Allen	354
Petrol Vapour. By “C. E. B.”	356
A Horizontal Single-Cylinder Engine. By Lawrence H. Sparey	358
Readers’ Letters	362
Queer Kites. By “D. B. M.”	365
Monthly Memoranda. By O. G. Thetford	366
Photo News	367
Aeroplanes Described—XVII. The Martin-Baker M.B.2. By H. J. Cooper	368
Club News. By “Clubman”	371

- (g) maximum time air borne is to be 2 minutes (to be controlled by a mechanical device approved by the S.M.A.E.);

The Council will be grateful if the Royal Aero Club will communicate these to the Model Clubs, concerned. A copy has been sent to the S.M.A.E."

This letter was received at the Royal Aero Club on Thursday, May 11th, and read over the 'phone to our Managing Editor. On the evening of the following day, the latter communicated with the Secretary of the S.M.A.E. by 'phone, asking formally for a copy of that letter. This was promised, but as it had not arrived by Monday morning, May 15, a call was made at the Royal Aero Club and a sight obtained of the letter received from the Air Ministry, as noted above.

Later, on the 15th, and under date of May 13th, the following letter was received from the Secretary of the S.M.A.E. :—

" Subject to the receipt from the Air Ministry of the official document, I am informed that the following new conditions affecting the flying of petrol driven models are as follows :—

1. The flying of petrol driven models shall apply only to members of the S.M.A.E. and under the following conditions :—
2. Span of models to be limited to 10 feet.
3. Engine run not to exceed 45 secs.
4. Model when airborne not to exceed two minutes.
5. All timing devices to be approved by the S.M.A.E. Council.
6. No petrol driven model to be flown within two miles of any aerodrome.
7. Models to fly in circles.
8. No petrol driven models to be flown between the hours of sunset and sunrise.

Members should know that rules governing the flying of petrol driven models necessitates the approval by the Council of the fitness of any flying ground for this purpose.

Applications should be made direct to the Hon. Competition Secretary, Mr. H. J. Towner, "Trencrom," Kings Drive, Eastbourne. The Air Ministry offer no objection to the flying of sailplanes incorporating a wing span up to 10 feet."

It should be noted that the various "conditions" given in the "Special Edition" of the "S.M.A.E. News" are *not* as set out in the Air Ministry letter.

This "Special Edition" of the "S.M.A.E. News" was undated, and circulated to the affiliated Clubs as early as May 10th, i.e., *several days before* receipt by the Royal Aero Club and the S.M.A.E. of the letter from the Air Council!!!

It was not until Monday, May 22nd that we received a letter dated May 18th, from the Secretary of the S.M.A.E. which set out the actual wording of the conditions laid down by the Air Council in their letter of May 10th.

Also included in the "Special Edition" of the "S.M.A.E. News" distributed about May 10th, was a notice which made reference to the formation of the Association of British Aeromodellers, and stated that "this proposed new Society will not receive the support of the S.M.A.E.". This notice was headed "A Message from the Council of the S.M.A.E." and at the end was "signed"—"Council S.M.A.E.".

We have the authority of the Chairman of the

S.M.A.E., Mr. A. F. Houlberg, who tells us that he did not see the "Message" until it actually appeared before him in the circulated copy of the "S.M.A.E. News," that he had no actual knowledge of who wrote the "Message," and that the Council as a whole did not see this "Message" before its publication. Mr. Houlberg adds that had he had an opportunity of seeing this "Message" before publication it would certainly not have taken the form it did, if it had appeared at all.

It may be noted that the flying of petrol driven models shall apply only to members of the S.M.A.E.!!! Under what authority does the S.M.A.E. arrogate to itself the right to discriminate as to who shall and who shall not fly petrol driven model aircraft in this country. We do not know . . . but we are quite sure that the Air Council, in issuing these "conditions," had no idea that it was discriminating between the relatively very small membership of the S.M.A.E., and the very large body of aeromodellers throughout the United Kingdom who are interested in flying petrol engine driven model aircraft and model gliders, but who are *not* members of the S.M.A.E. We are of the opinion that by this action alone the S.M.A.E. has shown that it is completely unfitted to handle matters affecting model aeroplane enthusiasts in this country. What prompts the S.M.A.E. to stipulate that time switches and other "mechanical devices" shall be subject to its approval, we do not know. We *do* know that the Ministry of War Transport stipulates that a motorist must carry on his car a "means of giving audible warning of approach," but we have yet to read that the Automobile Association or the Royal Automobile Club has authority from the Ministry of War Transport to "approve" all such warning devices.

Were the S.M.A.E. truly representative of the aeromodelling movement in this country, we would still stigmatise such "monopoly" as anti-social—but when the S.M.A.E., with a total "all in" membership of probably 4,000 or 5,000—the majority not interested in petrol engine driven model aircraft and/or model gliders—presumes to pose as an authority on time switches and other mechanical devices, and to lay down that only those models which are possessed by its own members shall be flown, then we say, with all the editorial force at our disposal, that we condemn the action of the Council of the S.M.A.E. as outrageous.

However, let us return to the notice issued by the S.M.A.E., both to the AEROMODELLER and to the affiliated Clubs. On whose authority was this "special edition" of the S.M.A.E. News sent out—before even the official letter had been received from the Air Council?

Who is responsible for the glaring omission in regard to the restriction on the flying of petrol driven models still remaining over a large area of England, i.e., that part of the country south of a line Southwold, Bury St. Edmunds, Bedford, Gloucester and the Bristol Channel?

Who is responsible for the omission of the vitally important restriction of the flying of petrol engine driven model aircraft and gliders "in officially prohibited areas" as well as within two miles of any R.A.F. Station?

We should have thought that on such an important matter the Council of the S.M.A.E. would have appointed a small Committee of petrol plane and sailplane experts to negotiate with and advise the Air Council. We know of no such appointment. Are we, then, to understand that the Council as a whole has negotiated with the Air Ministry, or have the negotiations been carried out by the Secretary (alone?) or by the Secretary and one

or more members of the Council? If so, what are their names?

"Never was so much muddle caused by so few, on behalf of so many."

We have thought fit, on behalf of the many thousands of our readers who are interested in petrol engine driven model aircraft and model gliders, to direct a communication to the Air Council, pointing out that, to our certain knowledge, the S.M.A.E. represents merely a few thousand model aeroplane enthusiasts, and that there exists, throughout the country, a vastly larger body of aeromodellers, including many experts in both types of model aircraft, who are not members of the S.M.A.E., and we feel sure that, on the Air Council being advised of this fact, they will realise the absolute inequity of the "conditions" which they have laid down.

In recording the above history, based on facts, we are well aware that we do so at a time coincident with the birth of a new Association—the Association of British Aeromodellers—the need for which becomes even more evident with such a monstrous gaffe as that made by the S.M.A.E., and we may be accused of some bias against the Society—inconsistent with the policy outlined in our leading editorial. We feel, therefore, that we should state that this Journal has persistently refused to publish criticism of the Society, and has endeavoured to support, encourage and build it up to be a really responsible body. Since the early part of the war, the proprietors of the AEROMODELLER have entirely paid for the cost of the S.M.A.E. Monthly Journal; the printers' bills have totalled some £200; the editing, proof reading and, recently, the binding of the Journal has been attended to by members of the AEROMODELLER staff, making a total cost of at least £250. A year ago this Journal offered the Society 50 guineas for two solid silver trophies for its Nos. 1 and 2 Solid Competitions, the winners of which have recently been announced. At the A.G.M. of the S.M.A.E., 1943, our Managing Editor offered the S.M.A.E. the sum of 100 guineas towards building up the Society's funds, provided it would obtain the services of a full time secretary and office accommodation of its own. During last year the Model Aircraft Trade was canvassed, and collected the sum of £200 to be added to this Journal's 100 guineas, for the same purpose. The proprietors of the AEROMODELLER have always given considerable space to S.M.A.E. reports, and only quite recently have borne the full cost of preparing and printing an 8-page pamphlet—"About the S.M.A.E."—at a cost of some £40.

No fair-minded person, therefore, will say that the AEROMODELLER, since coming under the proprietorship of our Managing Editor, Mr. D. A. Russell, has not tried to give, and, in fact, has given, substantial support to the Society—support which many readers may feel the average publisher would not have given. Let us record now that, so long as the S.M.A.E. continues in existence, space will continue to be given for its activities—provided, of course, that the appropriate information is forthcoming. Since the resignation of the Hon. Secretary, Mr. Laidlaw Dickson, some weeks ago, we have had no communication from the Society as to who has taken his place, neither have we received any news sheets or other literature. Neither did we receive winners names of the "Solid" Competitions until we had written to the Hon. Comp. Secretary asking for information.

Lest it be thought that the S.M.A.E. itself has been unaware of the size of the Movement and the fact that

its own members represented a mere 5 per cent. of the total number of aeromodellers in this country, we would say that, consequent on Mr. Russell and Mr. Rushbrooke having correspondence with the Chairman of the S.M.A.E. in September, 1943, Mr. Russell made formal application to address a meeting of the Council, with a view to laying before it information in his possession as Managing Editor of this Journal, and also as Chairman of the Manufacturers' Section of the Model Aircraft Trade Association, which would prove beyond all doubt that the number of aeromodellers in this country did, in fact, vastly exceed the membership of the Clubs affiliated to the S.M.A.E. Therefore the position was fast approaching when the Council of the S.M.A.E. would be literally misrepresenting their position by stating that they governed and controlled the Movement in this country. Our Managing Editor duly received a formal invitation from the Secretary of the S.M.A.E. under date of September 15th, 1943, and addressed the Council of the Society at its meeting on Sunday, September 26th. Mr. Russell gave, in confidence, figures of the sales of the publications of his group of companies, and turnover figures of the Model Aircraft Trade; and emphasised that, whilst the S.M.A.E. might claim to consist of some 180/200 affiliated Clubs, there were, in addition, many hundreds of Clubs throughout the country not affiliated. Many of these non-affiliated Clubs were sponsored by responsible organisations such as the A.T.C., the Boy Scouts Association, the L.C.C., Spotters Clubs, etc., whilst, in addition, there were many thousands of "lone hand" aeromodellers who were not actually members of any Club or Association: a total of probably 200,000.

Lastly, let us consider a few words which appear in the S.M.A.E. 8-page pamphlet to which we have referred above—"The Society of Model Aeronautical Engineers to be the body governing model aeronautics in Great Britain, by agreement with the Royal Aero Club." What exactly do the last 7 words mean? We understand that there is no "agreement" between the Royal Aero Club and the S.M.A.E.—there is no mandate. The whole of this deplorable "incident" in regard to petrol engine driven model aircraft and gliders has been dealt with between the S.M.A.E. and the Air Council. Whilst the two letters from the Air Council have been addressed to the Royal Aero Club, in each case they were sent on to the Secretary of the S.M.A.E., who has replied direct to the Air Ministry, in some cases without even sending a copy of the letter to the Royal Aero Club! Readers may draw their own conclusions as to just what degree or contact there really is between the Royal Aero Club and the S.M.A.E. . . .

Well, enough of this miserable business. The Council of the S.M.A.E. is to be congratulated on having obtained some alleviation of the restrictions on the flying of petrol engine driven model aircraft and model gliders. That it has concerned itself solely for the benefit of its own members is an action which, in a free country, it was entitled to do; but in our opinion no longer can the S.M.A.E. claim to govern the Movement, whether or not by agreement with the Royal Aero Club.

We shall continue to recognise the S.M.A.E. as an Association of probably 10 per cent. or 15 per cent. of the model aeroplane clubs in this country, but until it has vastly altered its organisation and outlook, this Journal will *not* recognise the S.M.A.E. as "controlling" the Movement or in any way representing the 150/200,000 enthusiasts in it.

A FOOLPROOF STRIPPER

BY GORDON ALLEN

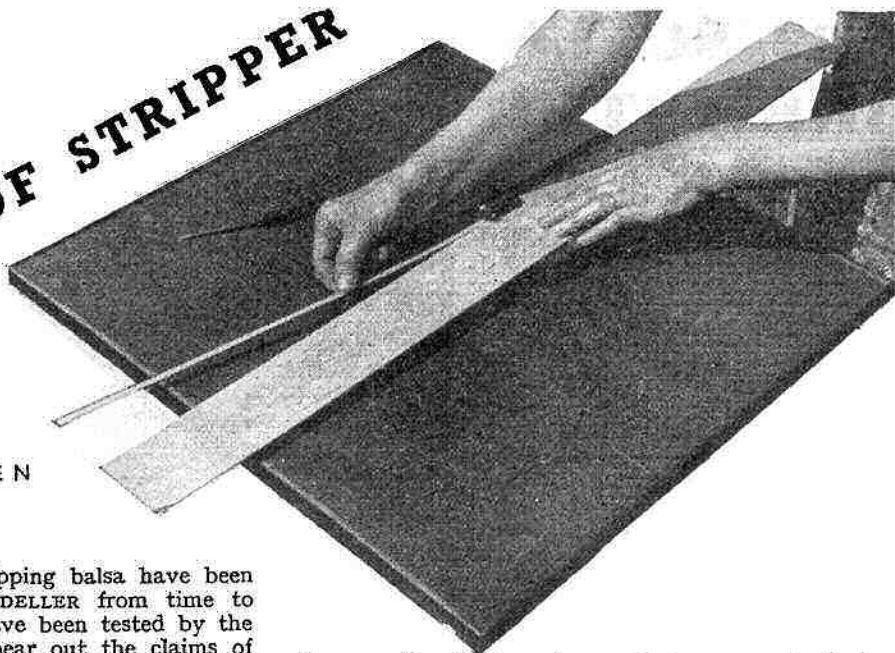

NUMEROUS gadgets for stripping balsa have been described in the AEROMODELLER from time to time, the majority of which have been tested by the writer. While most of them bear out the claims of their designers, a number failed in one or two details.

The result is that a stripper has now been designed which is absolutely foolproof.

The drawing is self-explanatory and therefore the method of construction should prove simple to follow. A few notes, however, will be helpful.

The base-block can be any convenient length and can be fastened to a bench by means of woodscrews.

The half-inch angle shown in the drawing is made of brass in the original and is held to the base-block by small woodscrews. The short length of angle is secured by two $\frac{1}{8}$ in. round-headed screws and square nuts.

Packing pieces made from metal plate (steel, brass, iron or aluminium) are clamped to one web of the angles by long cheese-headed setscrews and nuts. Cheese-headed screws are required to facilitate change over of the packing. These packing pieces are drilled

off-centre (that is, towards one side) to allow the timber to pass between the two sets of plates.

A piece of ordinary double-edged razor blade is clamped in place between the packing at an incline, as shown in the drawing.

Any thickness of balsa can be cut by selecting the corresponding thickness of plate (or combination of plates) and setting these against the angles followed by the blade and then the rest of the packing. The photograph indicates the method of operating.

A sheet of timber is moved firmly but smoothly over the base-block at the same time applying a pressure towards the angle.

For a little practice the reward will be strips which are perfectly uniform in section.

NOTE.—The sheet from which the strips are to be cut must have a straight edge at the outset.

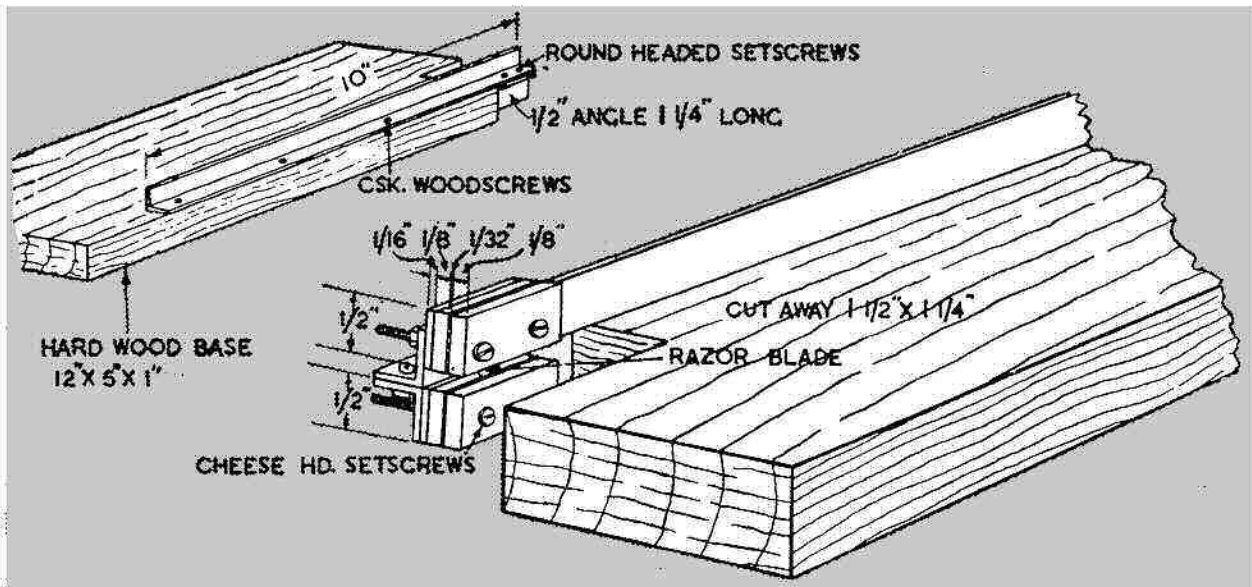

1/32 SCALE BREWSTER BUFFALO

BY J · A · F · HALLS

THE Brewster Buffalo, or F2A-2 as it is known in the U.S. Navy, is a single-motor mid-low-wing monoplane of corpulent proportions and as a first-line Fleet fighter has now been superseded by faster and more heavily-armed types.

It is powered by a Wright Cyclone nine-cylinder air-cooled radial motor developing a normal output of 900 h.p., and has a maximum speed of 313 m.p.h. at 13,500 ft. The usual operating speed is around 250 m.p.h., and the Buffalo has an initial rate of climb of 2,070 ft. per minute. With auxiliary fuselage tankage the range is nearly 1,500 miles.

The armament consists of four .5 machine-guns mounted two in the motor cowling and one in each wing, and there is provision for an external bomb-load of 200 lbs.

The fuselage is a semi-monocoque construction of light alloy, and the wings and tail-unit are metal structures with stressed skin covering. The movable control surfaces are fabric-covered.

The undercarriage retracts inwards into the fuselage and wings and is hydraulically-operated.

The Buffalo has a span of 35 ft. and is 26 ft. long. The wing area is 208.9 sq. ft.

Buffalo fighters arrived in this country in the summer of 1940, and after being tried out on operations were relegated to Training Command. Later versions were delivered to fighter squadrons in the Far East, but with the arrival of the Japanese S-00 on the scene were found to be of little use.

Buffaloes have also been delivered to the Belgian, Netherlands and Finnish Air Forces.

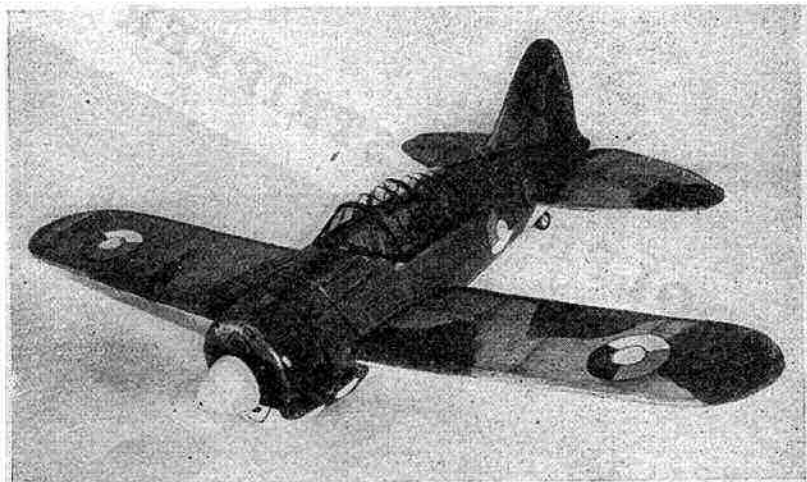

British and Dutch Buffaloes were camouflaged on the sides and upper surfaces with dark earth and dark green, and were light grey underneath. The modified Dutch marking consists of an orange triangle with a black outline, and this version is shown in the lower photograph.

Construction.—Fuselage: Cut out all formers from $\frac{1}{16}$ -in. sheet, cut out keels from $\frac{1}{16}$ -in. sheet substitute; pin on to plan. Cement on left half formers, checking that they are upright while setting; when set add stringers. Next build cowling: Cut out C1 and C2 from $\frac{1}{8}$ -in. sheet, cement together, cut out block to fit the square hole in C2. Cement CC (an $\frac{1}{8}$ -in. sheet disc) to this block, drill the block and cement in a length of aluminium tubing. Cement on 8 cowling spacers ($\frac{1}{8}$ in. by $\frac{1}{16}$ in.) spaced at 45 degrees, add C3, cover with $\frac{1}{16}$ -in. sheet. Remove fuselage left half and add right formers and stringers. Cement on the soft balsa block at the tail and the two $\frac{1}{16}$ -in. sheet rear motor peg attachments. Add cabin framework. Cement on rib A on each side.

Wing and Tail Unit.—Build direct on plan, as shown on plan. Wing and U.C. may be made detachable. The U.C. is made from 20 s.w.g. wire. Cover cabin with celluloid, cut out the dotted portion of K3 and K4, cement on a piece of celluloid to represent the lower view panel. Cement on tail-unit. Cover fuselage and tail-unit, add tail wheel and radio mast. Cover wings. Spinner either built up with $\frac{1}{8}$ -in. sheet discs or turned on a lathe, drilled to take aluminium tubing, hollowed at rear to take three cup-washers. Prop. shaft 18 s.w.g. Prop. blades set at 30 degrees pitch angle.

Power with four loops of $\frac{1}{8}$ -in. flat rubber (it *does* exist in limited quantities).

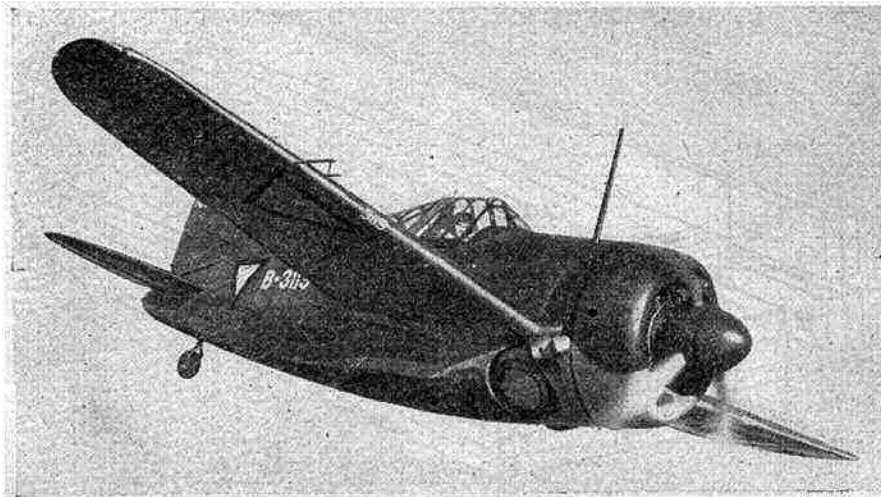

The model above has a useful performance R.T.P. Note that it carries the old type markings, since modified as shown by the full size aircraft on the left.

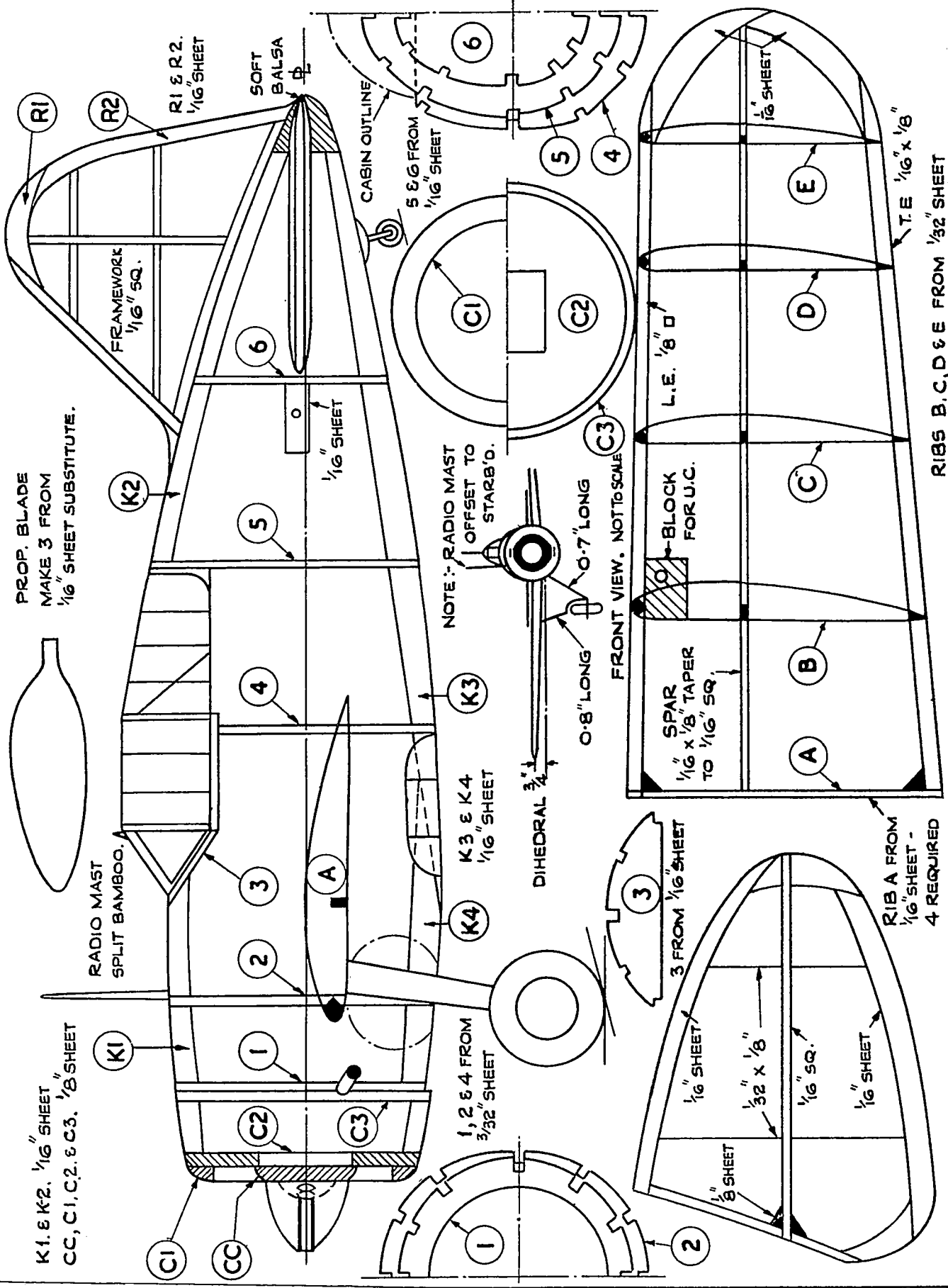

K1 & K2, 1/16" SHEET
 CC, C1, C2, & C3, 1/8" SHEET

RADIO MAST
 SPLIT BAMBOO, A

PROP. BLADE
 MAKE 3 FROM
 1/16" SHEET SUBSTITUTE.

FRAMEWORK
 1/16" SQ.

SOFT
 BALSA

CABIN OUTLINE

5 & 6 FROM
 1/16" SHEET

NOTE :- RADIO MAST
 OFFSET TO
 STARB'D.

DIHEDRAL 3/4"

0.8" LONG

0.7" LONG

FRONT VIEW. NOT TO SCALE

SPAR
 1/16" x 1/8" TAPER
 TO 1/16" SQ.

BLOCK
 FOR U.C.

L.E. 1/8" D"

1/8" SHEET

1/16" SQ.

1/16" SHEET

32" x 1/8"

1/16" SHEET

RIB A FROM
 1/16" SHEET -
 4 REQUIRED

RIBS B, C, D & E FROM 1/32" SHEET

T.E. 1/16" x 1/8"

C1
 CC

1, 2 & 4 FROM
 3/32" SHEET

K3 & K4
 1/16" SHEET

K2

5

4

3

2

1

1

2

3

3 FROM 1/16" SHEET

C1

C2

C3

A

B

C

D

E

6

5

4

R1

R2

R1 & R2,
 1/16" SHEET

THE CALCULATION OF DOWNWASH OVER A STABILISER

BY J. K. ROBINSON, B.Sc.(Eng.)

FOR various reasons, the stabiliser mounting on a modern streamlined model usually suffers from the disadvantage that the incidence cannot be altered. Consequently, trimming the model can be a very difficult business, and is often only accomplished with the use of weights, which contribute nothing to the strength of the structure and may seriously impair the flying qualities of the machine. Hence it is of vital importance to be able to estimate as accurately as possible the angle at which the stabiliser should be set, and this necessitates determination of the angle of downwash of the air flowing over the tail surfaces. This downwash arises from the fact that, for the wing to give a lift, it must deflect the air downwards, and the amount of the deflection is calculable from aerofoil theory.

We assume the usual horseshoe vortex system shown in Fig. 1, consisting of a single spanwise vortex and two others, parallel to the longitudinal axis of the aircraft, and stretching backwards to infinity. The basic equa-

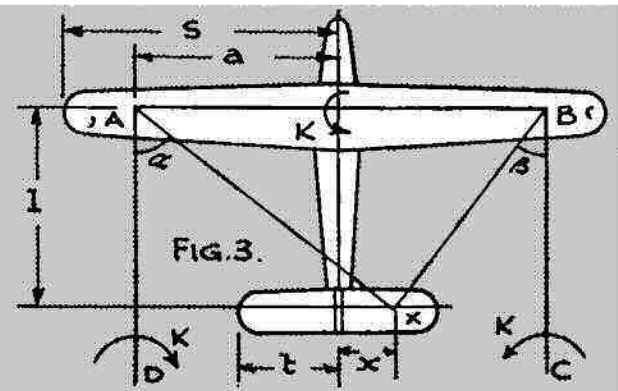
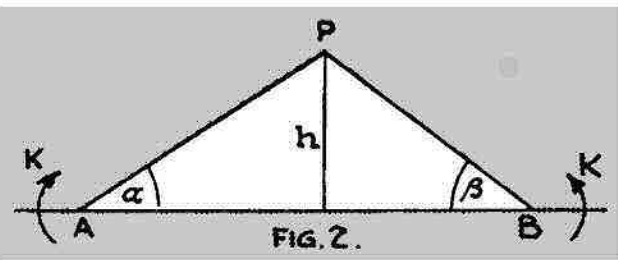
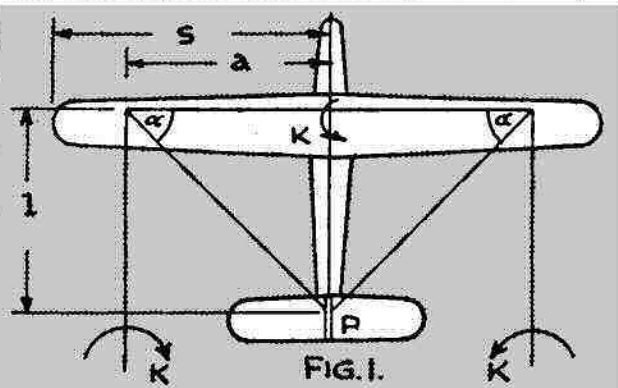

tion of the theory concerns the velocity induced at a point near a vortex, as shown in Fig. 2. AB is a finite length of a vortex of strength K , and P is any point distant h from the axis of the vortex. Denote by α and β the acute angles which PA and PB make with AB. Then the fundamental equation is that the velocity w at P, due to the length AB of vortex is given by:—

$$w = \frac{K}{4\pi h} (\cos \alpha + \cos \beta)$$

The direction of this velocity being normal to the plane of the figure and downwards into the paper.

This equation is now applied to the vortex system shown in Fig. 1. If we take the point P to be at the centre of the stabiliser, as shown, then with the notation given at the end of the article, the above equation readily gives the relationship:—

$$w = \frac{K}{4\pi l} (2 \cos \alpha) + \frac{2K}{4\pi a} (1 + \sin \alpha) \\ = \frac{K}{\pi} \left[\frac{1}{2l} \cos \alpha + \frac{2}{\pi s} (1 + \sin \alpha) \right]$$

since aerofoil theory gives $a = \frac{\pi}{4} s$.

But the wing lift $L = k_L \rho U^2 Z = \frac{\pi s}{2} \rho U K$.

$$\therefore K = \frac{2}{\pi} \cdot \frac{Z}{s} \cdot U k_L = \frac{8}{\pi A} U s k_L$$

as $A = \frac{4s^2}{Z}$.

Hence

$$w = \frac{8 U s}{\pi^2 A} \left[\frac{1}{2l} \cos \alpha + \frac{2}{\pi s} (1 + \sin \alpha) \right] k_L$$

so that the angle of downwash $\left(\frac{w}{U}\right)$ is

$$\frac{4}{\pi^2 A} \left[\frac{s}{l} \cos \alpha + \frac{4}{\pi} (1 + \sin \alpha) \right] k_L \text{ (radians)}$$

and finally, in degrees

$$\epsilon = \frac{720}{\pi^2 A} \left[\frac{s}{l} \cos \alpha + \frac{4}{\pi} (1 + \sin \alpha) \right] k_L$$

This formula, then, gives us the angle of downwash at the centre of the stabiliser, and provided that this surface is fairly small and of low aspect ratio, the value will vary only slightly over the whole surface of the stabiliser. If, on the other hand, the stabiliser is large, and of high aspect ratio (say, eight or nine), its tips will be fairly close to the cores of the trailing vortices from the wing, so we cannot assume that the downwash there is approximately the same as that at the centre. Another method of calculation is therefore necessary, and for this we refer to Fig. 3. A general point X is taken on the centre of pressure line of the stabiliser, and distant x from the centre. The downwash velocity w_x at this point is then seen to be composed of three parts:—

(1) Due to AD.

$$w_1 = \frac{K}{4\pi} \cdot \frac{1 + \cos \alpha}{a + x}$$

(2) Due to BC.

$$w_2 = \frac{K}{4\pi} \cdot \frac{1 + \cos \beta}{a - x}$$

(3) Due to AB.

$$w_x = \frac{K}{4\pi} \cdot \frac{\sin \alpha + \sin \beta}{l}$$

and w_x is the sum of these. This sum may be integrated graphically if desired, but by expressing it in terms of one variable (x) only, the operation may be performed mathematically, and much time saved in the application of the final result. The operation of eliminating all the variables except x is simple enough, but we are left with a long and complicated expression which is tiresome to integrate. Luckily, however, several of the terms cancel one another out, and the remainder can be conveniently grouped in the form:—

$$\int_0^t w_x dx = \frac{K}{4\pi} \left[\log \left(\frac{a+t}{a-t} \right)^2 \cdot \frac{l+P}{l+Q} + \frac{Q-P}{l} \right]$$

where $P^2 = l^2 + (a-t)^2$ and $Q^2 = l^2 + (a+t)^2$ and the logarithms are to the base e . (2.718).

The average downwash velocity over the stabiliser is obtained by dividing the integral by the distance between the limits of integration, i.e., t . Then manipulation on the lines given previously yields the result:—

$$\epsilon = \frac{360}{\pi^2 A} \cdot \frac{s}{t} \left[\log \left(\frac{a+t}{a-t} \right)^2 \cdot \frac{l+P}{l+Q} + \frac{Q-P}{l} \right] k_L \text{ degrees.}$$

This formula is simple to apply, since all the constants can be measured direct from plans of the model in question, with the exception of the aspect ratio and the lift coefficient, which are very easily obtained.

It is well to note the following assumptions made in the theory:—

(1) The wing is elliptically loaded. This is very nearly true when a high aspect ratio is employed, what-

ever the wing plan-form may be.

(2) The trailing vortex sheets from the wing are completely rolled up by the time they reach the stabiliser. This assumption is not strictly true, but in the absence of experimental data, it is difficult to estimate the errors involved.

(3) The stabiliser is situated on the same horizontal level as the wing. The theory may be extended to include variations in stabiliser level, but for most models, the assumption holds within reasonable limits.

(4) The centre of pressure lines of both wings and stabiliser are normal to the longitudinal axis of the aircraft. If, however, sweepback is employed, the effect on downwash will be negligible provided that the sweepback is small compared with the length of the stabiliser moment arm.

LIST OF SYMBOLS EMPLOYED IN THE TEXT:—

- K = Strength of a vortex (sq. ft./sec.).
- l = Distance between the centres of pressure of wing and stabiliser (ft.).
- s = Semi-span of wings (ft.).
- t = Semi-span of stabiliser (ft.).
- a = Half the distance between the trailing vortices of the wing (ft.). Aerofoil theory gives $a = \frac{1}{2}\pi s$.
- k_L = Lift coefficient of wings.
- ρ = Density of air (= 0.00238 slug/cu. ft.).
- U = Forward speed of aircraft (ft./sec.).
- Z = Wing area (sq. ft.).
- A = Aspect ratio of wing.
- ϵ = Angle of downwash (degrees).
- π = 3.142.

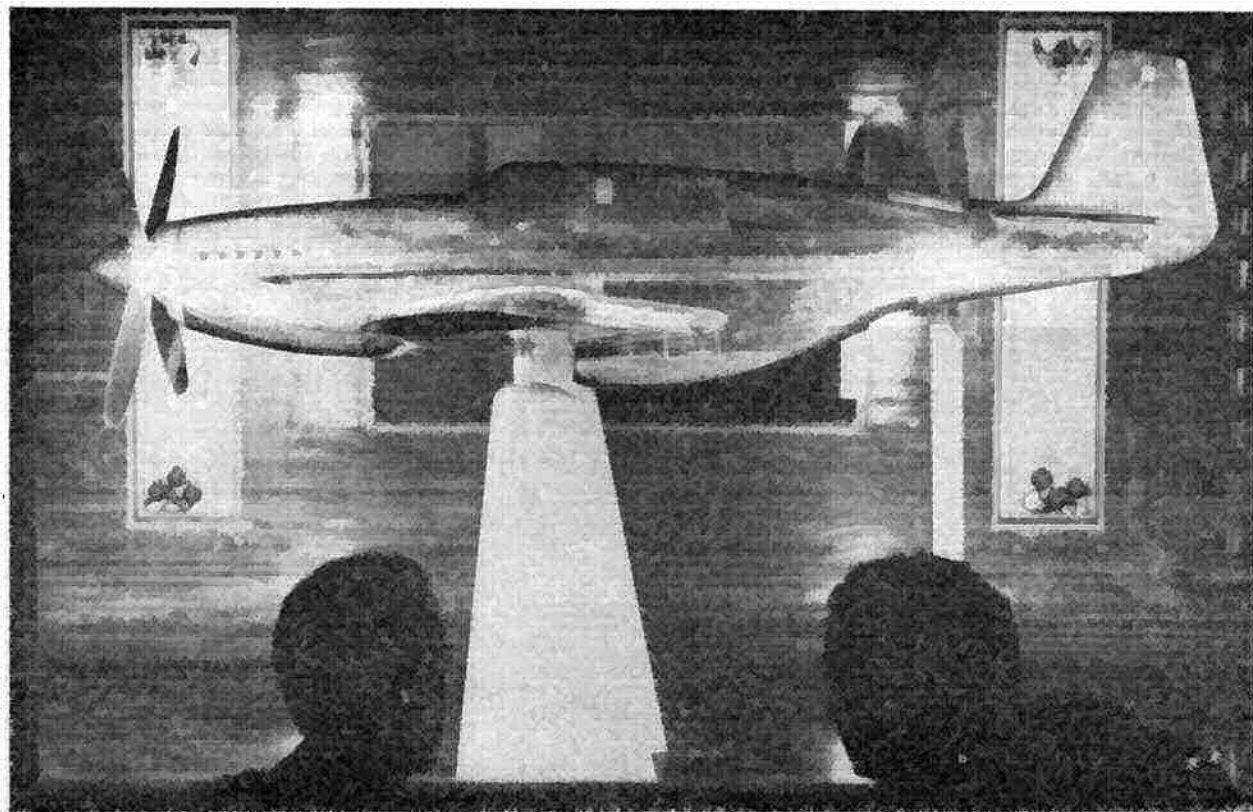

Calculations on test! Experts watching the results of wind tunnel tests on a model of a P-51 Mustang Fighter at the California division of North American Aviation, Inc. The sleek lines of the newest Mustang are well brought out by this model, equipped with a four-blade airscrew.

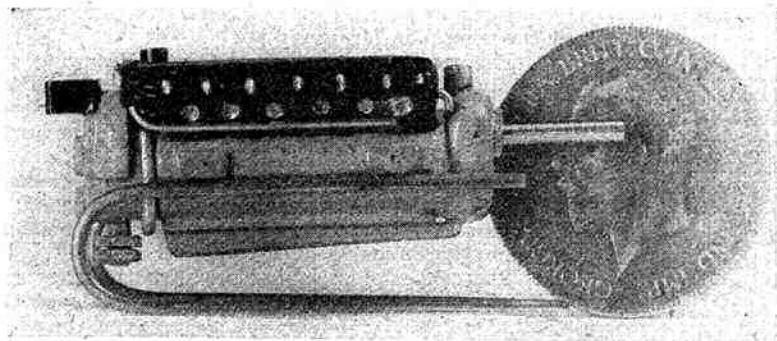

1/48th SOLID SCALE MODEL MOTORS

ARTICLE V

ALLISON 12 CYL. AERO ENGINE

BY "S.B.S."

Some idea of the finished size of this engine can be obtained by comparing it with the penny.

THIS month's model, the first American in the series so far, is of the Allison 12 cylinder, liquid cooled, in-line Vee, rated at about 1,100 h.p. The angle between the cylinder blocks is 60 degrees. The main drawings show front, side and rear views, a plan, and a section through the centre of the crankcase and cylinders.

All drawings are to the full 1/48 scale, and all the major parts are shown with two views.

C, the crankcase, should be easy enough, though the angle of the Vee needs care. J is merely a disc which might be made of good card; I used 1/16 in. plywood sanded down to thickness. H, the cylinder blocks, two of which are required, are finely rounded off on the top edges and have 6 holes of 3/64 in. diameter drilled in the positions shown on the side view. The holes, which need not be of any depth, are to simulate the exhaust ports. On the top edges of the blocks, midway between the ports, tiny grooves are filed with a triangular file: these represent the flutes in the cylinder heads for the bolts. The blocks are completed by winding a strand of 36 s.w.g. wire round at about 1/16 in. from the top; this represents the flange. Nip it at the tapered end of the block, give it a coat of clear dope to stick it, and when secure, pare off the waste leaving a square end so that the distributors, G, can be cemented on.

Part A, the reduction gear housing, I made in two parts so that the front half could be grooved like the cylinder heads, again to simulate bolt positions. The tiny piece sitting on the top of A is made of 11 gauge needle.

The two small rectangles shown on the centre line of the crankcase below the first and last exhaust ports are the mounting lugs. There are two on each side, and a pin hole is drilled in each at centre.

The end casing, E, is made up of three pieces; in the parts drawings shown as E, F, E. First the angle piece, then the three-quarter circle, which is the blower case, then the small rectangle at the end. On this latter are mounted the auxiliary drives which are shown in the rear view as three circles and a tiny square. The circles are: two at 8 gauge needle, and one at 11 gauge. The square I cut out from 8 gauge material. Directly above these parts sits piece M, the carburettor.

Between the pieces G, is fixed a short piece of 11 gauge needle, K, and from the bottom side of each piece G, a length of 20 s.w.g. tinned copper wire runs along the cylinder blocks, stopping just short of the first exhaust port. This is the magneto conduit, and there is one on each side. A similar conduit leaves the pointed end of the parts G and lies along the top of the cylinder heads, resting on the hairpin shaped part L. This latter is the induction feed to the cylinders and is made of 17 s.w.g. wire bent to the shape shown. In the loop at the right-hand end, a short piece of 11 gauge needle will be seen in the plan view. This is the magneto, and it should be about 1/4 in. long. The colour is blue, by the way.

D, the pump under E, is made of 6 and 11 gauge needle: I drilled out the larger size to be a firm fit on the thinner section, drilling E to take the latter, as it makes a stronger job.

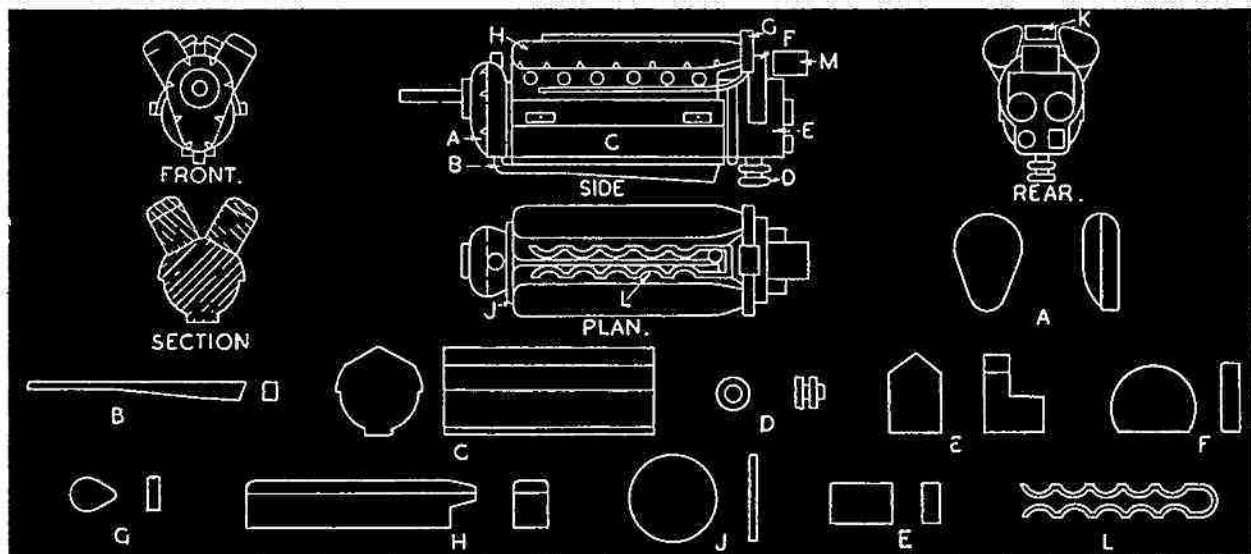

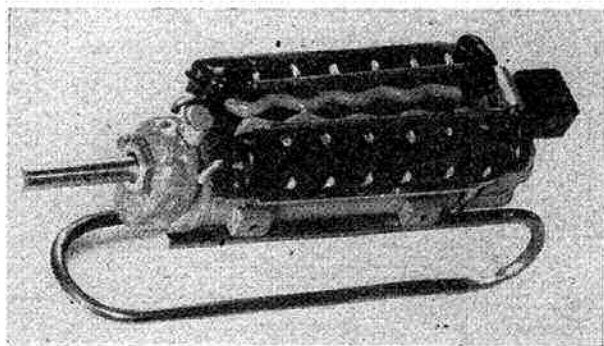

Round the block E, immediately where it butts against C, a short length of 17 s.w.g. copper wire is fitted: shape it to a neat fit and secure with clear cement.

As to colouring: A, B, C, D, E, should be a greenish grey, according to the makers' advertisements, and H, G and M are glossy black. The fluting in the cylinder heads and part A, I picked out with a touch of silver paint to define the bolts. K is also silver; likewise the pipe round E, and the magneto conduits. Exhaust ports are shown up with a dab of silver using a very fine brush, and the wire L, which is a casting in actual practise, is coloured the same grey as already mentioned. A bright nail of 1/16 in. diameter fits in a suitable hole in A and serves as the prop. shaft, and a small brass washer in its natural colour slides over it and is cemented to A and finishes the job off.

There are three main versions of this motor, the one shown being as used in Mustang and Lightning.

HARDWOODS

BY R · S · WELFORD

IN view of the fact that balsa to the model-maker nowadays is rarer than diamonds and that those of us who continue to build models have had to fall back upon what hardwoods we are able to obtain, I think that the following list of the weights per cubic inch and weights comparative to balsa of the most common hardwoods may be useful to modellers who design their own models.

The column giving the weights comparative to balsa should be most useful to duration model designers, who are usually so intent upon weight reduction. A study of this column will show how heavy in comparison to a balsa-built model any proposed model in the chosen hardwood would be, and may enable the harrassed modeller to keep the weight somewhere within the chosen limit by warning him in time to resort to composite construction if he is lucky enough to have a little balsa left for the purpose.

The data is as follows:—

Wood.	Weight per cubic inch.	Weight comparative to Balsa.
Balsa	·075	—
Obeechi	·174	2·3 times as heavy.
Poplar	·219	2·93 " "
Spruce	·317	4·22 " "
Cedar	·358	4·69 " "
Pear	·381	5·08 " "
Walnut	·387	5·16 " "
Cherry	·416	5·54 " "
Birch	·420	5·60 " "
Ash	·486	6·48 " "
Beech	·491	6·54 " "



Why No! Merely the insignia on a Spad of the 135th U.S. Squadron during the 1914-18 Great War.

How did we know? . . . Well, we found this and a great deal of other useful information in "CAMOUFLAGE 1914-18 AIRCRAFT" by O. G. Thetford, a book invaluable for reference purposes to all interested in aircraft, and of especial interest to all scale modellers. It is complete in every respect with eight plates in full colour of both British and German aircraft camouflage, machine-guns, airscrews, etc., and over a hundred fuselage silhouettes with squadron markings.

WHAT "AERONAUTICS" SAY



We agree with 'Aeronautics' that the title of this book does not do it full justice. No title of a few words would do justice to such an invaluable reference work

"CAMOUFLAGE 1914-18 AIRCRAFT"

80 pages: size 8½ in. by 5½ in. with full colour cover.

PRICE 3/6 OR POST FREE 3/10½ FROM
HARBOROUGH PUBLISHING CO., LTD.
ALLEN HOUSE, NEWARKE STREET, LEICESTER

THE BLACKBURN BLUEBIRD IV

BY
E. J. RIDING



Photo by E. J. Riding.

THE Blackburn Bluebird IV was the final development of an original design for a side-by-side two-seat light aeroplane produced by the Blackburn Aeroplane Company of Brough, East Yorks., for the 1924 Light Plane Trials at Lympne. The prototype Bluebird G-EBKD, was of mixed metal and wood construction and was at first fitted with a three-cylinder Blackburn radial engine of 1,100 c.c. capacity. For the 1926 trials, a 75 h.p. Armstrong-Siddeley Genet five-cylinder radial engine was installed, but the machine was disqualified during the eliminating contests after damage to the undercarriage. The same machine was destroyed by fire after being involved in a mid-air collision with the first Westland Widgeon at the Bournemouth Whitsun Meeting in 1927.

The production Bluebird IIs and IIIs were similar in most respects to the prototype, and in 1929 they were succeeded by the Bluebird IV, which at that time was the only completely metallised light aeroplane on the British market.

The fuselage was of mixed steel and dural tubular construction with drawn section dural stringers supporting a fabric covering. The wings had I-section drawn steel strip spars with dural sheet ribs. Frise-type ailerons were fitted to the bottom planes only and Handley-Page automatic slats to the top planes. The undercarriage employed steel springs in compression with oleo dampers. Petrol was carried in a 24-gallon centre-section gravity tank, and the prospective buyer had a choice of three types of power plant—the 95 h.p. A.D.C. Cirrus III, the 100 h.p. D.H. Gipsy I, or the 115 h.p. Cirrus-Hermes I four-cylinder in-line air-cooled engines.

Owing to pressure of work, the Blackburn Company arranged for Messrs. Saunders-Roe, Ltd., of Cowes, to take over the production rights, and about 54 machines were built by this concern. A large batch of Bluebird IVs were to have been supplied to National Flying Services, Ltd., in 1929, but only ten were delivered. These machines bore the registration letters G-AAOA to

G-AAOJ inclusive. The rest of the batch were to have been registered G-AAOK to G-AAOZ inclusive, but as the order was not completed, the numbers were never issued. Others were supplied to the North Sea Aerial & General Transport Co., Ltd., for use at their Reserve Training School at Brough, as well as to many private owners.

Bluebird IVs competed in the King's Cup Races of 1930, '31 and '32, no less than ten machines of this type being entered in the 1930 race. The only outstanding performances were made by G-AATN and G-AACC, which gained 3rd and 6th places respectively. 'CC won the race the following year at an average speed of 117 m.p.h. and four other Bluebirds retired. 'CC was again entered for the 1932 race but was forced to retire through a petrol leak.

Between 1930 and 1935 there was a series of unfortunate accidents, nine of which were fatal, involving Bluebird IV aeroplanes. At low speeds, or when stalled on a climbing turn, the machine was dangerous in the hands of an inexperienced pilot, since it had a tendency to flick over into a spin, with resultant loss of height before control could be regained. It is possible that the rather broad fuselage had something to do with this habit.

Of the 52 Bluebird IVs registered in this country, 20 were destroyed in crashes, 10 were sold abroad, and 4 were still on the register at the outbreak of war. The rest came under the category of "lapsed," or were cancelled for various reasons.

The accompanying photograph shows G-AACC as a privately-owned machine at Yeaton in August, 1935, the colour scheme being aluminium all over with dark blue letters and struts. It was dismantled at Hooton aerodrome during the early part of 1938.

Specification: Two-seat, side-by-side training and private owner's biplane; span, 30 ft. 0 in.; length, 23 ft. 2 in.; chord, 4 ft. 6 in.; wing area, 246 sq. ft.; wing loading, 6.48 lb. sq. ft.; power loading, 16.8 lb. h.p.; max. speed (Hermes I), 120 m.p.h.; landing speed, 45 m.p.h.; climb, 730 ft./min; range, 320 miles.

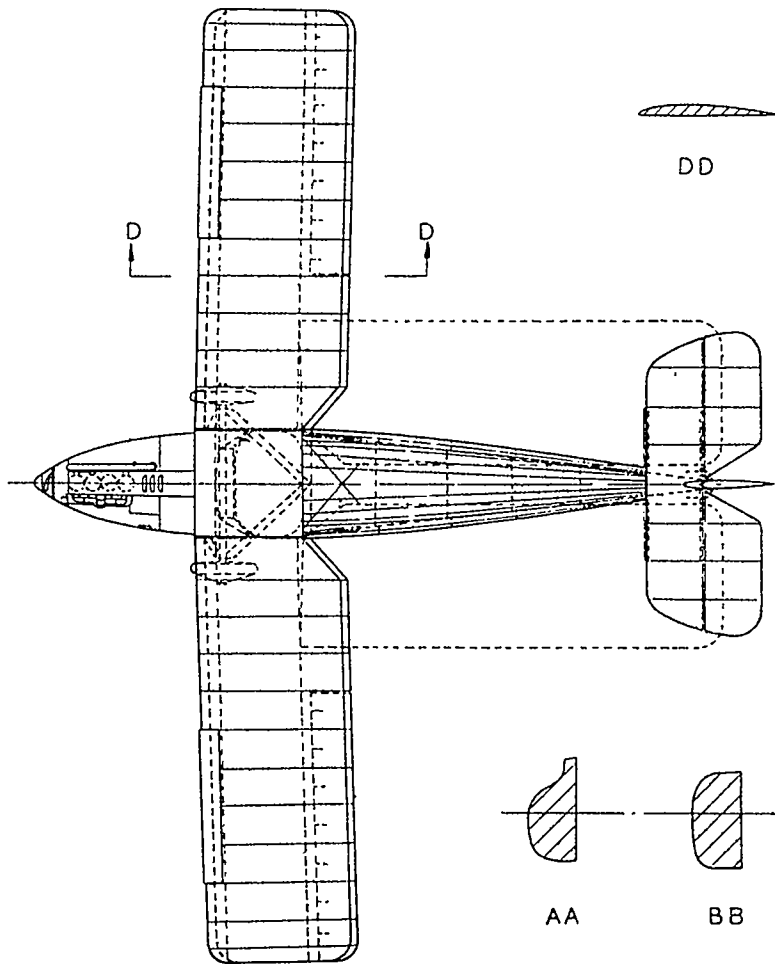
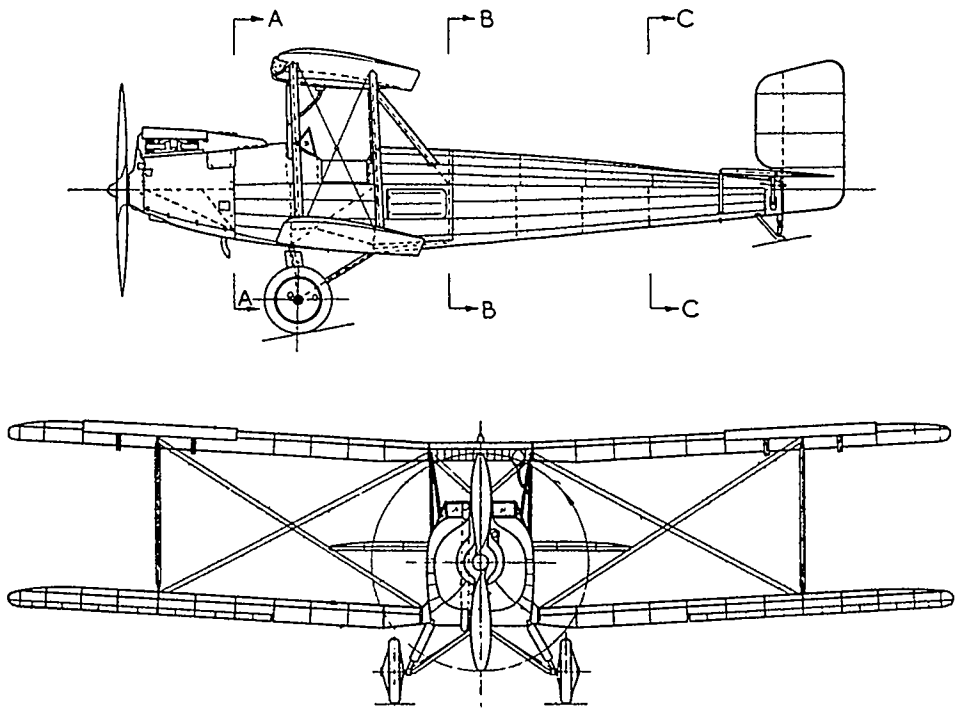

“ . . . IN TEN SECONDS FROM NOW . . . ”

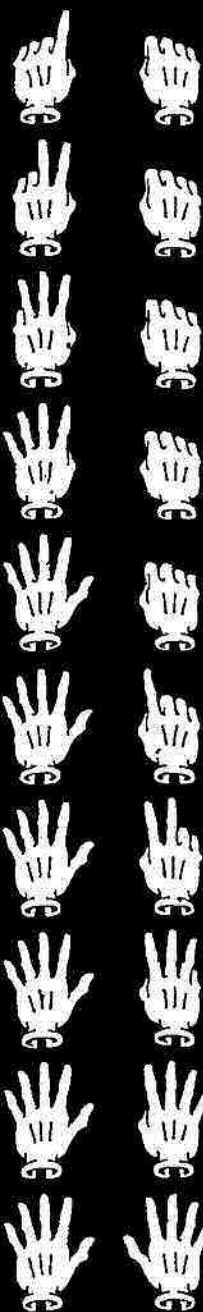

What famous monoplane could land and take off on a football pitch?

Who built a ‘‘flying-wing’’ monoplane in 1923?

How were the deck-landing wires of early aircraft-carriers arranged?

Which single-seat fighter was looped on its initial test flight?

Who landed a cabin biplane in a field to gather mushrooms?

Which single-engined aeroplane first featured internal bomb stowage?

Who was Woyevodsky?

Name the biplane, built as a torpedo-bomber, which conquered the world’s highest mountain?

Who flew the only seaplane used at the Battle of Jutland?

What biplane carried two 37 mm shell-guns?

Which monoplane’s wings could be moved while it was in flight?

Who had a private air force of four biplanes?

How did the famous D.H.9A biplane originate?

What was the armament of the C.O.W. Gun Fighter?

YOU KNOW? THEN YOU HAVE OBVIOUSLY READ THE BOOK OF WESTLAND AIRCRAFT



Compiled by A. H. Lukins and Edited by D. A. Russell, M.I.Mech.E.
With a Foreword by Lord Brabazon of Tara.

*A 1/12nd
Solid Scale*

BEAUFIGHTER

BY P. O'KEEFFE

THE "Beaufighter," besides being a nice-looking 'plane, is typical of the new multi-cannon multi-seat fighters now making their appearance, and a carefully made model will be a pride to the person who spends the time making it. The model described in this article was constructed from the plan, obtainable from the AEROMODELLER Plans Service, Ltd.

The fuselage is made in two halves, and while it is being shaped it can be held in one piece by two strong pins. A good idea is to cut a cardboard template the shape of the fuselage elevation, and sandwich it in between the two fuselage blocks. The shaping can then be easily done by cutting the outline as far as the template. This template must be removed, however, before the curved shaping of the fuselage can be done, otherwise it will make the outline incorrect. When the outer shaping has been done, templates can be made for the inside, being about 1/16 in. smaller than the outer templates. The inside is then carefully gouged out. A space should be cut at the rear to accommodate the tail wheel, which is made from a piece of tube for the axle, wood for the wheel proper, and a small piece of twine for the tyre, arranged as shown. The stirrup is hinged into the fuselage by pushing the wire ends into the wood when the two halves are stuck together. The whole inside should be sanded well down, given a coat of filler, and sanded down again, then two coats of silver dope. The floor can now be cut from "substitute," and is best stained, the escape hatches being marked on the wood in indian ink before the staining is done, in the positions shown. The floor is now cemented on to one side only, and the interior fittings added, as shown in the diagram. All small fittings can be made from wood or wire, or both combined, all suitably painted. The pilot's seat is made from a small piece of leather for the back, preferably green. If the leather is dampened, and the lines shown are scored with a blunt tool, or piece of pointed wood, a more realistic effect will result. The bottom of the seat is made from a piece of thin foil, such as a piece of old cement tube. With the point of a pencil, raise the edge by pressing round it on the reverse side. It is then stuck on a small block of wood affixed to the floor, and the leather back cemented on, sloping slightly backwards as shown. The observer's seat is made similarly, but it has two metal arms, these can be cut from one piece of foil. The edge of the seat is scored round as before, and the arms bent to their



correct positions. Two pieces of inverted U-shaped florists' wire are stuck on either side under the seat, to form the legs, and should be slightly splayed out to the angle shown. The legs are then cemented to the floor. The instrument panel is a piece of card, painted with indian ink, and leaving the gauges, etc., white, and cemented into the cockpit. The two fuselage halves are now complete, and can be carefully cemented together, not forgetting to stick the edges of the floor and instrument board showing. Any cracks along the joins can be filled and sanded perfectly smooth. A pea-lamp bulb can now be cemented in where shown, and the wires put through a hole in the floor, and two holes in the bottom of the fuselage, for the time being. This must, of course, be added before the two halves are put together.

If desired, the complete set of cockpit and observer's dome covers can be bought ready-made, but it is much better to make both. With a pin make four holes in the cockpit edge, just where the two main cover supports come, and make two florists' wire supports to fit these holes, and which follow exactly the shape of the rear edge of the open cockpit, roughly an inverted U. On an oak piece of wood, make four more holes, exactly the distance apart in each direction as those on the cockpit edge, and put the supports in these. Then cut the small pieces of wire which run from each of the supports to the other, the length being got from the plan. A pair of tweezers, preferably with spade ends, now come in handy, as the small pieces of wire can be held in position while each end is soldered to the U supports. The bottom piece is shaped as shown, to fit the cockpit edge, and soldered at its points of contact with the upright supports. The pilot's clear-view panel is next fitted, and consists of an inverted U-shaped wire, held at a suitable angle to the bottom wire, and soldered at its two ends. The two curved pieces joining the front support to the clear-view panel are next fitted, and lastly the two straight pieces which form a triangle on each side, near

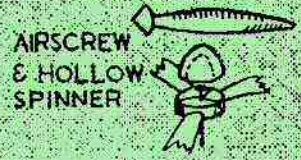
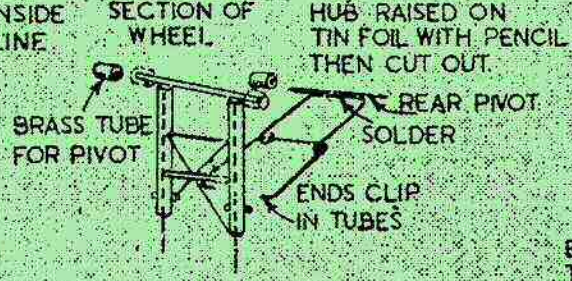
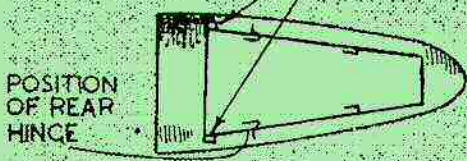
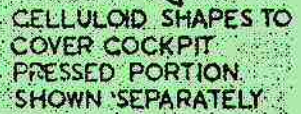
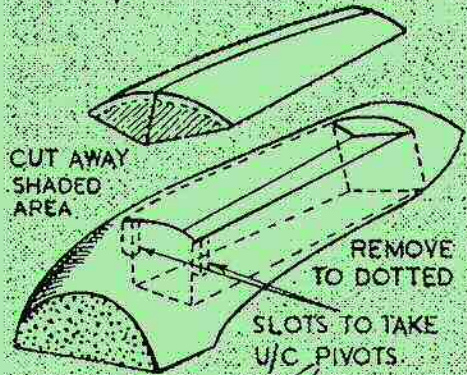
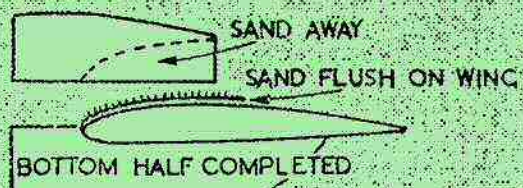
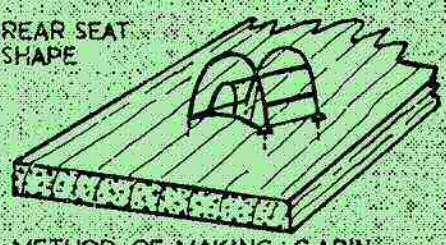
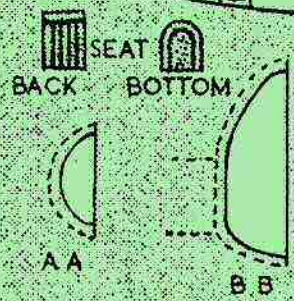
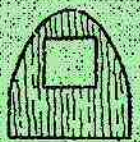
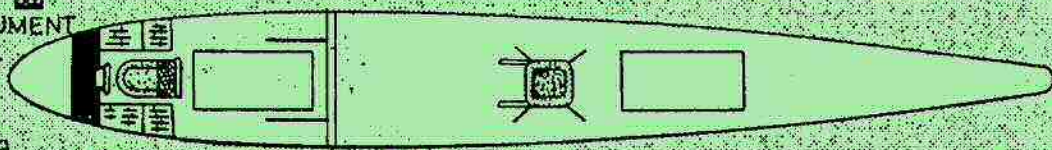
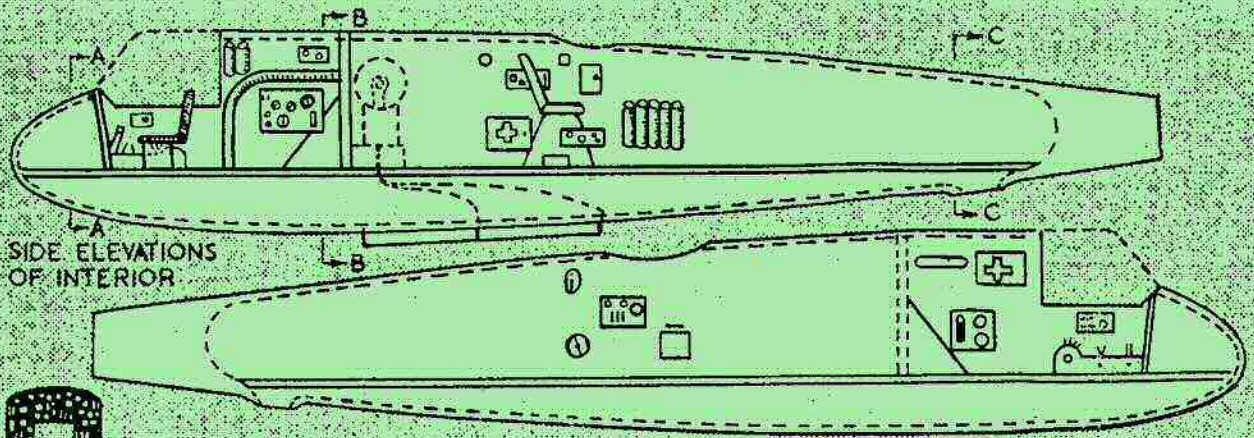

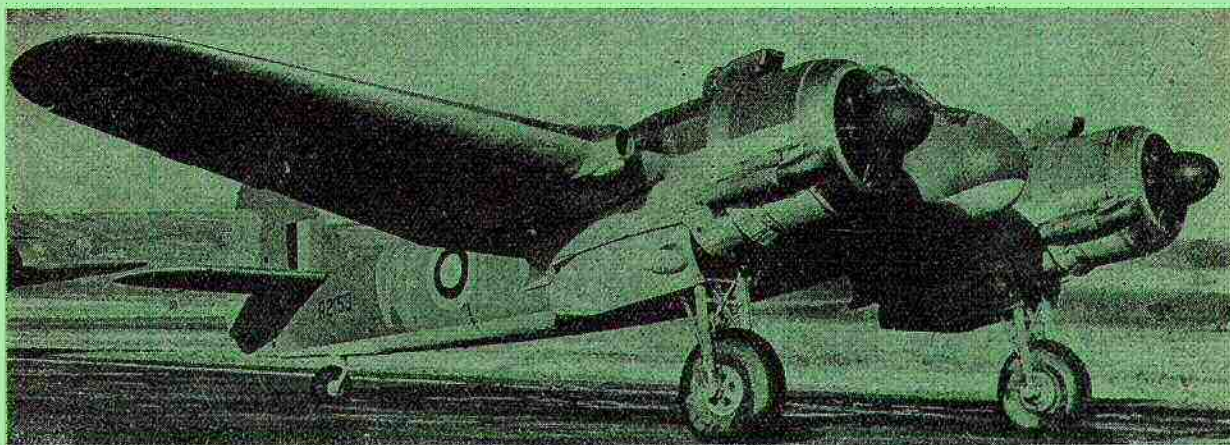

Air Ministry Photograph.

to the front. Remember to keep the soldering iron very hot, and only hold it on each joint just long enough to fuse the solder on each part. Once complete, the framework should be covered with celluloid. One strip will cover the main part, between each main former, then one on the front clear-view panel, two pieces on each side of this, and one shaped piece at the front on top. Now to shape this, and also the observer's dome, we will need two formers. Two pieces of wood are shaped to the exact size and shape of each piece required. They are then waxed with candle grease, and layers of plastic wood applied to the curved surfaces only, until a thickness of about $\frac{1}{8}$ in. is built up. The inside shapes can then easily be removed and two perfect formers with which to make the celluloid shapes are ready. A piece of celluloid is then soaked in hot water, laid over each hollow section of the moulds, and the shaped wood pushed in firmly. When dry, remove shape from mould, and carefully remove the celluloid, which should now be the shape required. The mould can then easily be opened by gripping the pin with a pair of pliers, and gently easing one half from the other. The cockpit and observer dome covers should now be put on one side and left until the whole plane is painted and assembled, before being fixed.

The tailplane, fin and rudder can now be made in three separate parts, and fixed to the fuselage. The control surface lines should be marked on by cutting a narrow V-shaped line along the joints. It is recommended that this should be done with a razor blade, or balsa cutter. The blade should be carefully run along the line dividing the elevators from tailplane, and rudder from fin, sloping slightly to the right, then turn the part round, and repeat when a V-shaped line will be formed. Be sure to get the two tail parts horizontal with the fin at right angles to them.

The wings can now be constructed in the usual way, each with a centre panel, and an outer panel, the dihedral being fixed by setting the outer panel at an angle to the inner one where they join, any cracks being filled in with plastic wood, and sanded smooth. The control surfaces dividing lines are marked on in the same way as the tail surfaces, with a V cut. The wing-light sections are cut out, and left until the whole is painted. The complete wings can now be cemented in place to each side of the fuselage. Any cracks can again be filled with plastic wood, and the fillet made up from the same useful material, shaped with the fingers. Sand the whole completely smooth when dry.

Now comes another intricate job, namely, the engines, nacelles and undercarriage. The nacelles are best

made in two halves, being shaped to fit the wings by holding a piece of sandpaper as shown, on the wing, and rubbing first the top half of the nacelle on it, until it fits, then the bottom half. The halves are then shaped and sanded smooth. On the bottom half draw on the undercarriage door outline, and carefully remove both as shown, then divide them through the middle, and cut away any surplus wood until the doors are about $\frac{1}{32}$ in. thick, or a little more. The whole inside of the bottom section can then be removed as shown. A small piece of tubing can now be cemented on each door where shown, and a pin, with head removed, and bent at right angles, can be inserted into each side of the bottom half of the nacelles. The tube on each door will eventually slip on to these pins. The two nacelle halves can now be cemented together, but should not be cemented on to the wings yet.

It is best now to construct the undercarriage and wheels. The main legs are made from tubing, with wire, for the lower half. Join the legs together with a length of wire across the top, leaving about $\frac{1}{8}$ in. jutting out each side, where it will be hinged. A cross-brace is put in lower down, and the thin X bracing wires made of florists' wire, and soldered on. On each leg a small ring of wire, or a small section of tubing is soldered where shown. Two rear supports from florists' wire are now made for the undercarriages, and made in two parts as shown, hinged at the middle. A pin is soldered at the top of each, with the head removed. They should also jut out about $\frac{1}{8}$ in. either side, and the rear struts will hinge on these pins. The bottom ends, turned in about $\frac{1}{16}$ in., should now be clipped in the two rings on the main legs.

The wheels come next, and can either be bought, or made as described here. Two circles of wood are cut, and the edges rounded in the form of a tyre. The inside of each should now be removed with a gouge. Now get some lead foil, and putting a piece under the diagram shown as "Wheel hub," pencil round the rim firmly. Remove the foil from the back of the diagram, and on the bottom will be a raised circle, which will form our rim. If the impression is not clear, put the foil face-down on a book, and press into the groove made by our first pencil mark, firmly and evenly all the way round. Then, with a rounded instrument, push on the back of the foil, at the centre of the rim, and twist the rounded end about, so forming a bulge on the reverse side. Turn over, and you will have your complete hub, all but cutting it out, and making a pinhole in its centre. Four of these are made. The hubs are then cemented round the inside



of their rims, and stuck on to the wooden tyre, being sure to get the holes in alignment. A jig such as shown, made of any old piece of wood, should now be made, to facilitate the fixing of the wheel and its axle on to the undercarriage struts. The axle is of thin wire, and after the wheel is slipped on a paper or thin card washer should be put on each side, to prevent the solder running, and fixing the wheel to the axle. Then on each end slip a small piece, about $1/16$ in., of tubing, holding it on the end by putting a touch of cement on the inner edge, and fixing it to the card washer. Lay the wheel in the hole in the jig, with the axle on the board, slide the bottom ends of the undercarriage legs up to it, so that each end touches the small piece of tubing, and touch each with a hot iron, well covered with solder. This will fuse axle, tubing and undercarriage leg together, and the whole assembly can be lifted off the jig when cool.

The next parts to make are the engines, cowlings and airscrews. The engines consist of two banks of 7 cylinders, made by winding florists' wire in a tight coil round a piece of circular rod. One bank is cemented on round the central core, which is of wood, and another cemented behind it, in a staggered position. The cowlings are made on a waxed former, from plastic wood, and sanded to a smooth outline when finished. They are best made with the front filled completely in, then when dry the front opening can be cut with a balsa cutter while the cowling is still on the former. The airscrews are made from three pieces of wood as shown, which are cemented together, and are arranged on the plan. When complete a hole is made in the centre, and a pin passed through, making sure the airscrew spins freely on it. Spinners are then made from plastic wood, over a waxed former, so that they are hollow. When complete they should be cemented on to the airscrew hub, and will cover the head of the pin. The engines can then be fixed to the front of the nacelles, and after cooling gills have been scored on the cowling, similarly to the control surface outlines, they also can be cemented over the engines.

The undercarriage is now to be fixed in the nacelle. Two slots, one on either side, are cut at the front of the cut-away part of the nacelle, but only about half-way down, and only half-way through the wood (see diagram). A small piece of tubing approximately $\frac{1}{8}$ in. long should be slipped on each piece of wire which juts out at the top of the main undercarriage legs. The slots recently made should be smeared with cement, and the tubing, with wire inside it, slid into these slots, until the undercarriage is in its correct position. When each

of these is done, the rear struts can be attended to, and the ends jutting out at the top of these are forced into the wood on the inside of each nacelle, in the position shown. A slot is now gouged out of the wing to allow the wheel and struts to sink right down. When done, the nacelles can be cemented in position.

Now add any small items, such as exhaust pipes, oil coolers, supercharger air intakes (make from thin card), and the bulges on the undercarriage doors. If a bulb was fitted the wires should be run along in the bottom of the 'plane, and soldered to metal supports as shown, one positive, and one negative. A third support is fixed as shown, which has no use other than helping to support one of the two wires which will be added later. Any escape hatches, cannon gun grooves, machine gun holes, etc., are marked out and cut to shape with V grooves or holes. The landing lights are made of foil, suitably shaped as shown, and cemented in. Wing tip lights are small coloured pieces of wood added as shown.

The paintwork can now be added, and a good filler, with fine sandings, used before any dope or paint is applied. Too much time cannot be spent over the finish, as it is all important. When finished, the insignia can be added, either by painting on direct, using transfers, or by using the method of making tissue-paper roundels and letters described in December, 1942, AEROMODELLER. The pitot tube and wireless mast can now be added, and the observer's dome stuck on. If required, the cockpit hatch can be hinged as shown. Another small detail which will enhance the finished article is a pilot, made of wood or any suitable plastic material, and painted grey. The two pieces of wire which will join on to our small terminals, or supports, under the fuselage, are now fixed. The rear one is put on first, and is fixed to the middle support by a liberal drop of cement, so insulating it from this terminal, but soldered to the rear terminal, making contact with it. The front piece can be soldered to both the front and middle supports, as it will then make contact with the middle support, the front one being only used to hold the front of this wire, and having no electrical connection. It can now be seen that one length of the wire is positive, and one negative, by reason of their contact with the middle and rear supports, and each is insulated from the other by reason of the cement, which leaves a layer of celluloid between the two at the middle terminal. The interior can then be lighted by connecting a length of wire from each pole of a battery to these two lengths of wire.

Any little extras shown on the plan, which need no description, should be added to complete the model.



FROG

SCALE
MODEL
AIRCRAFT



MADE IN ENGLAND BY
INTERNATIONAL MODEL AIRCRAFT LTD

For the sole Concessionaires

LINES BROTHERS LTD · TRI-ANG WORKS · MORDEN ROAD · MERTON · LONDON · S.W.19 · ENG



ELECTRIC MOTOR

FOR 1/72 SCALE IN-LINE ENGINED AIRCRAFT

BY F. DUDLEY

IN the issue of AEROMODELLER for September, 1943, there was a description of an electric motor suitable for radial engined aircraft. The writer has recently constructed one small enough to go into the fuselage of an in-line engined aircraft of 1/72 scale.

The motor is $1\frac{1}{4}$ in. long and will slide into a $5/16$ in. hole, actually it is .308 in. diameter. The armature and commutator both have three sections. The field magnet is wound and two silver brushes are fitted. The armature shaft is a darning needle, .040 in. diameter. It is self starting in most positions but it can be made so by putting the heaviest blade in a suitable position when fixing the airscrew to the shaft. It will turn a $2\frac{1}{2}$ -in. airscrew at a fair speed. Voltage is limited to 3, as the motor gets warm while running.

The only lathe available for the machining was of 6 in. centre, maximum speed 600 r.p.m. and very inaccurate. Some of the drilling proved difficult. However, means were found to overcome these difficulties, and it is considered that the motor is not unduly difficult to make for the average worker.

BUILDING INSTRUCTIONS

The following instructions should be carefully followed and the parts made in the order given to avoid several snags. It will be seen that certain measurements can be varied without detriment. Obtain $\frac{3}{8}$ in. diameter iron bolt or similar black iron bar (not mild steel). Chuck and turn down to slide in a $5/16$ in. hole, reducing the portion shown in sketch 1, to $\frac{1}{2}$ in. Centre and run in $3/16$ in. drill for $5/16$ in. Follow with $1/16$ in. drill for a further $3/16$ in. and run in $\frac{1}{4}$ in. drill so that full diameter of drill cuts down for $21/32$ in. (see sketch 11). Lightly bore out this portion to remove drill marks. Drill through at points marked A (sketch 1) with $\frac{1}{8}$ in. drill and file away shaded part. Part off leaving a $1/16$ in. piece full size at left hand end. On this left hand end (one hole will now be in the centre), drill two $1/16$ in. holes at opposite sides as close to the edge as possible, sketch 2.

Select a darning needle, cut off the eye and stone the end smooth. Measure (the one shown in photograph is .040) and obtain a drill the same size. Make the three pieces shown in sketches 3, 4 and 5. The holes are drilled with this small drill.

For the armature cut off a further piece of iron $7/16$ in. long and turn the outside to fit the large hole in field magnet at B with a mere trace of play. Cut down both sides of field magnet with a hacksaw and file out to about $3/32$ in. wide as shown at D sketch 1. Drill armature blank with the small drill.

The writer found it easier to drill first and mount between false centres in 3 jaw and tailstock drill chucks. In this case leave blank $\frac{1}{2}$ in. too long for a driver, finally cutting excess off. Divide the end of the blank into three as sketch 7, drill a $1/16$ in. hole down each side of the lines, cut each section lengthways with a saw and file out to leave the shape of each section as shown by the heavy lines in sketch 7. Slide on needle, put on end bearings and see that it spins freely in field magnet.

File slightly (from end to end) if necessary. Remove all sharp edges.

Commutator.

Chuck a small piece of brass rod and drill slightly larger than armature shaft, turn down a $\frac{3}{8}$ in. length to $5/64$ in. and a further $3/16$ in. or so to $1/16$ in. or less. Mark along the $5/64$ in. portion with the tool level with the centre of each chuck jaw. Remove from chuck and saw, with fret saw (or any fine blade), along each mark to the $1/16$ in. portion. Carefully remove burrs. Select some paper which, when put in the slots as shown in sketch 8, makes it a push fit on shaft as far as it will go at present. Put on with shellac varnish (or similar) and allow to dry. Cut off excess paper with a razor blade. Make a fixing ring (insulating) to fit over commutator tightly, $3/32$ in. wide and a little over $\frac{1}{2}$ in. outside diameter. Push on commutator and cut off surplus brass at the end of slots as shown in sketch 6. Remove burrs and push along shaft. Test with lamp and battery between sections and each section and shaft. Scrap if shorted. Now lightly solder armature to shaft putting the small bush (sketch 4) between armature and end plate, allowing a trace of end float. The commutator is fixed with shellac about $\frac{1}{2}$ in. to the left of armature (see sketch 11). Obtain some of the thinnest wire you can get (the writer used an old HF choke) and wind each section of armature in exactly the same way. The finishing end of one section is the start of the next as shown in sketch 9. It should be possible to get in 44 to 48 turns on each pole. Clean the ends and solder one to each section of the commutator. Tin first (resinous flux), and give one quick touch with iron, also solder in the left hand bearing. Now wind the field magnet with the same wire going from left to right and back again (two layers on each pole), taking care to wind second pole in the opposite direction

as shown in sketch 11. Test for shorts, wire to field magnet. Rewind if shorted. Gently file the outside of the commutator securing ring so that it revolves without touching winding.

Brushes.

In two outer holes of end, sketch 2, fix by wrapping with paper and a little shellac, two pieces of brass or copper wire $3/32$ in. inside the motor and about $1/4$ in. outside to make brush holders. Fix firmly. Obtain small piece of silver or brass and hammer lightly to thin out and cut two L-shaped pieces. Solder to brush holders as shown in sketch 10, at the same time solder the two wires from field magnet, one to each brush holder.

Get the brushes as long as possible, thin and springy.

The motor is now complete. Assemble but do not solder right hand bearing yet. Try with 3 volts (it will get warm on $4\frac{1}{2}$). The commutator may require turning on the shaft a little (shellac will not stick it too tightly). Oil most sparingly, using very thin oil. Cut off the point of the needle to required length, solder the end cap (two spots only), fix spinner with propeller. It will easily take up to 2 in. diameter propeller.

Finally, a few notes. Tin the iron parts with acid and wash off and solder with resinous flux when assembling.

Better methods of making will no doubt be discovered by readers as experience is gained. This winding gives clockwise direction of rotation. To make anti-clock, change over the leads to brush holders. As there is no room for insulation, do not pull the wire too tightly when winding.

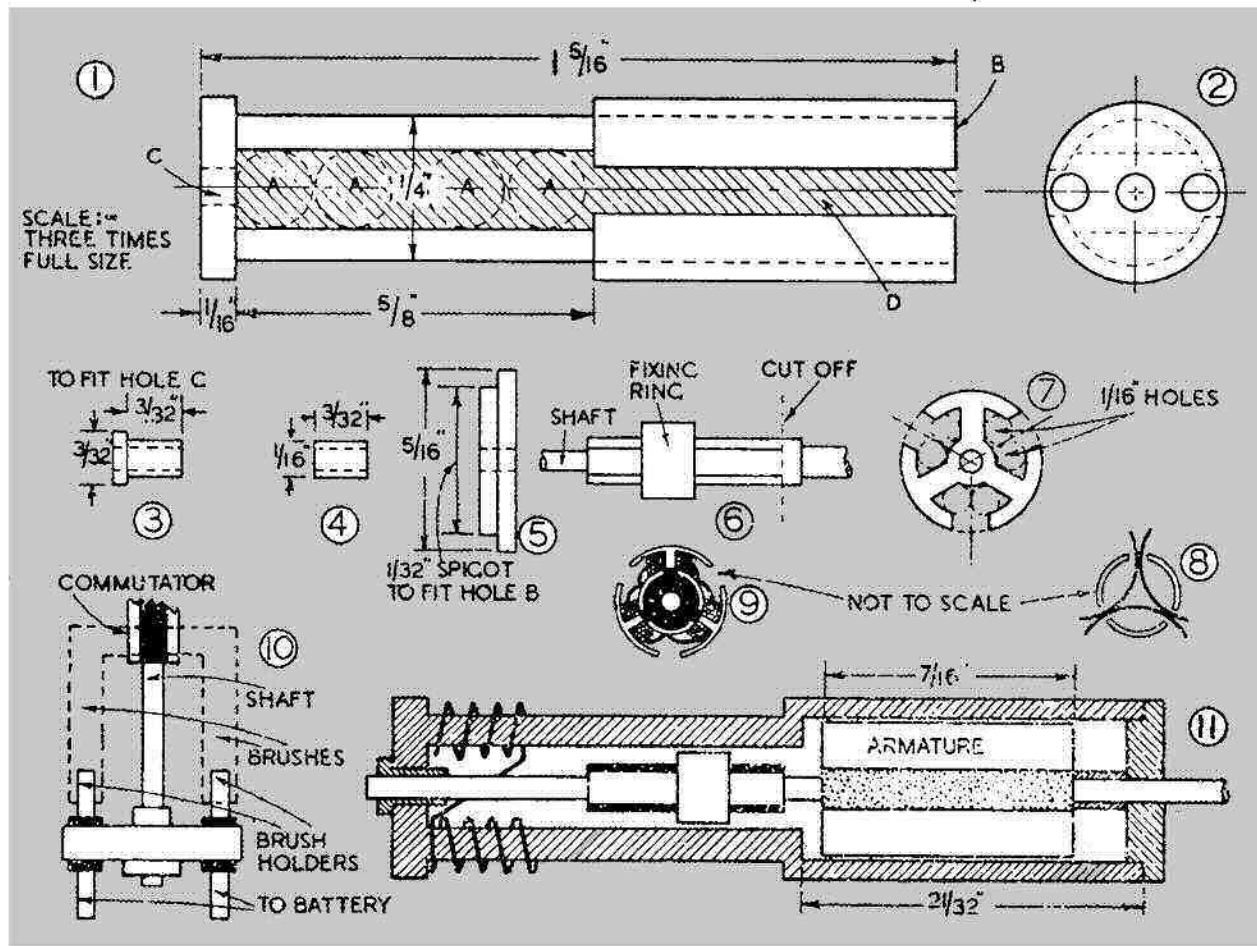
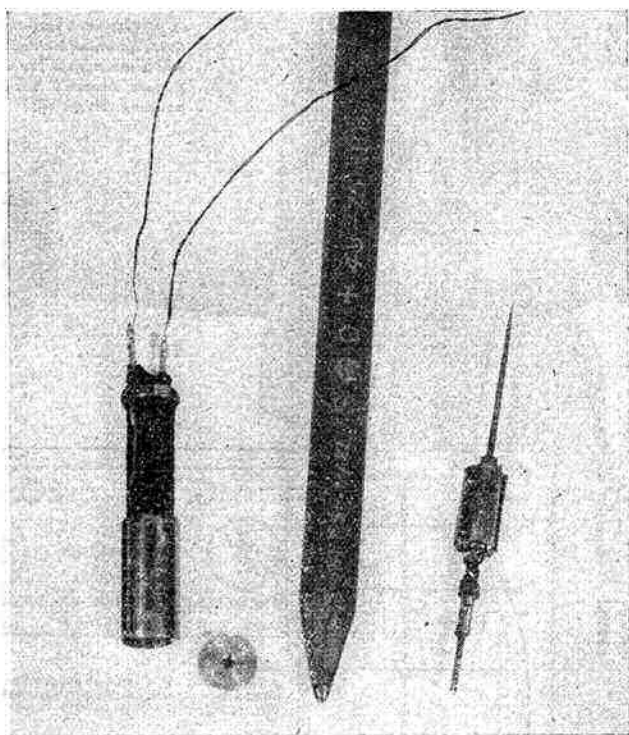

PLAN 1/3 SCALE

BY G · W · W · HARRIS

G. W. W. Harris with the G. H. 20, which incidentally is the subject for C. Rupert Moore's cover painting this month.

THIS machine was designed for duration competitions including those run under Wakefield rules. As will be seen from the drawing it is a simple and straightforward job, which is an important consideration these difficult days. It is, however, strong and reliable.

The original model was first flown in 1942, when it was entered in some local competitions, where it won the Midwood Challenge Cup and Farnborough Trophy.

Owing to the local club temporarily ceasing operations, I decided to try my luck with G.H.20 at Epsom in Blackheath's Gala Day. It won first place in the open duration event. This win spurred me on to have a try at a National Competition, so I entered the 1943 M.E. No. 2 Cup competition; this it won with two flights, the second was O.O.S.

It is not, I think, necessary to describe the model in detail since its construction follows orthodox practice.

the following remarks may help anyone desirous of building it.

1. The machine will fly in pretty foul weather, so it is worth double covering the fuselage, also use a good quality dope.

2. The tail plane ribs are slightly cambered, so you must stick the covering to the ribs, underside only, of course.

3. A small amount of flight trimming can be done by inserting narrow strips of paper between the tail unit plug and the rear end of the fuselage.

The Airscrew W.P. Type.

Carve from soft balsa, develop the blade with care from the shaped block. The blade should be as thin as you dare make it towards the tip. Reinforce the leading edge and tip with one or two coats of hard drying cement. Use a non-shrinking dope such as banana oil on the blade, this will avoid the possibility of distorting the

blade. If the hinge arms are made sufficiently flexible, it is possible to get a variable pitch action, within certain limits, of course. The blade assuming its maximum angle, i.e., coarse pitch position at the beginning of the flight, then returning back, progressively to its original position (fully fine) as the torque diminishes.

Stops to prevent the blade reaching excessive angles were not found necessary when using motors consisting of 14 or 16 strands of 1/4 in. by 1/24 in. black rubber.

This flexibly-mounted blade type of airscrew has proved itself to be well worth further experiment. I have made repeated tests with this particular airscrew in comparison with my fixed pitch types, and I am sure it is superior, inasmuch as the model continues to climb where before, with a fixed airscrew, it would have levelled out.

In conclusion, I would add that I quite realise the limitations of the airscrew described, but I do regard it as a step in the right direction.

G H 20 DURATION MODEL

FULL SIZE PLANS 20" x 40" PRICE 8/- POST FREE FROM THE AEROMODELLER PLANS SERVICE LIMITED

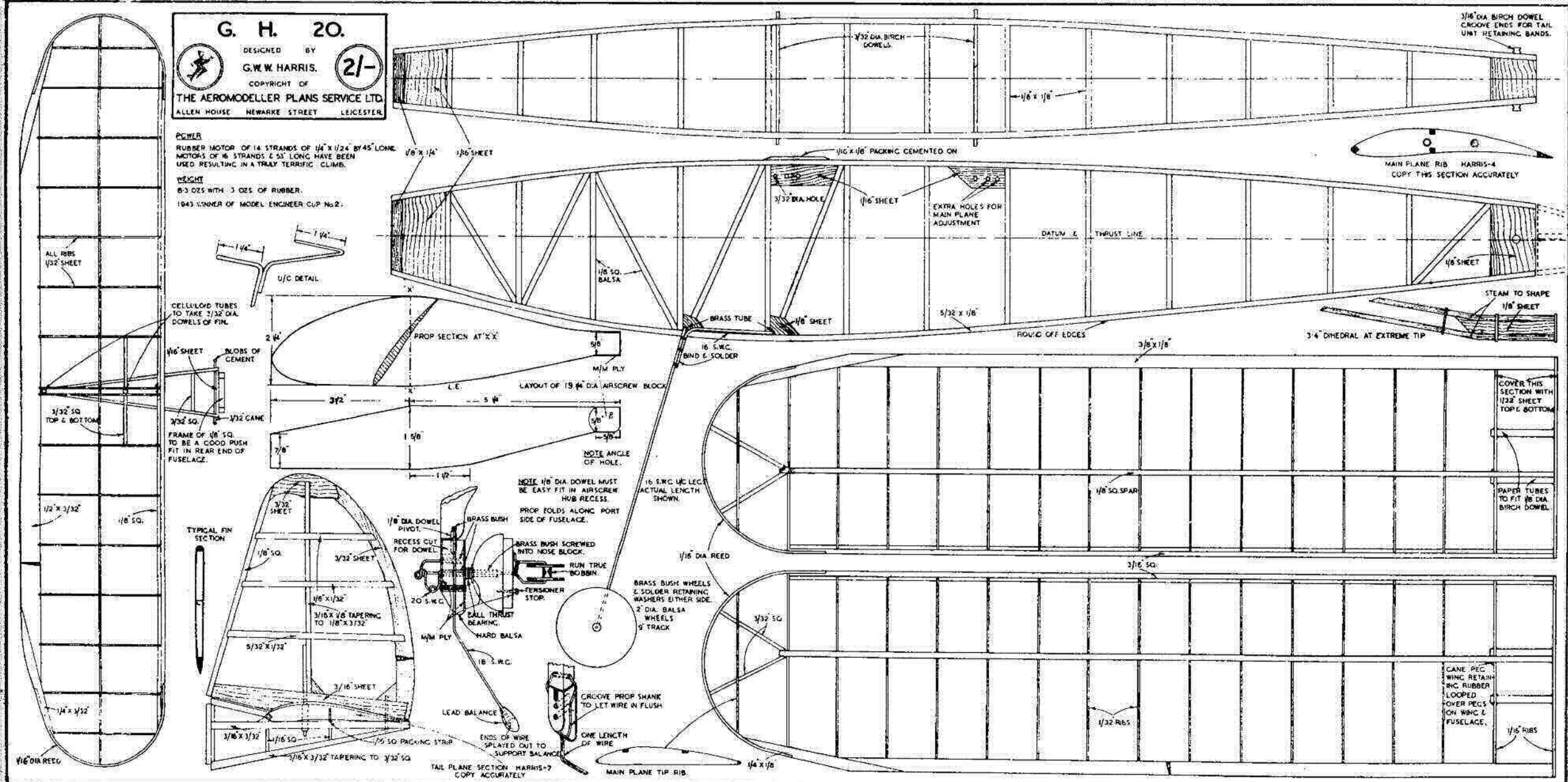

G. H. 20. DESIGNED BY G.W.W. HARRIS. COPYRIGHT OF THE AEROMODELLER PLANS SERVICE LTD. ALLEN HOUSE NEWARKE STREET LEICESTER.

POWER RUBBER MOTOR OF 14 STRANDS OF 1/4" X 1/24" BY 45" LONG. NOTIONS OF 16 STRANDS 6 5/8" LONG HAVE BEEN USED, RESULTING IN A TRULY TERRIFIC CLIMB. WEIGHT 8.3 OZS WITH 3 OZS OF RUBBER. 1943 WINNER OF MODEL ENGINEER CUP No. 2.

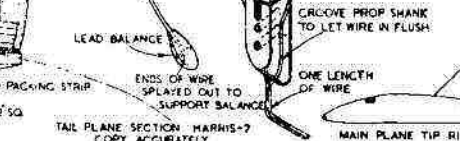
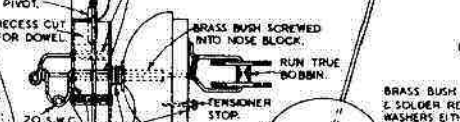
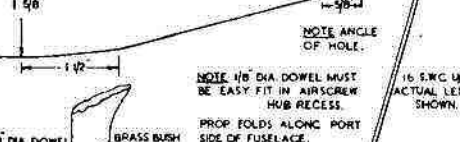
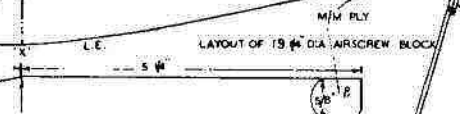
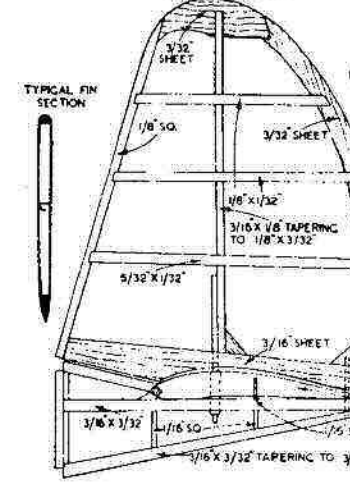
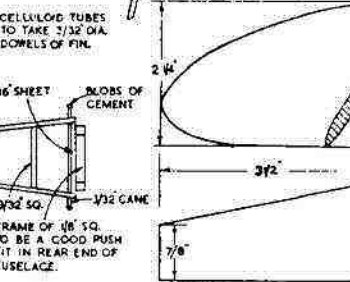
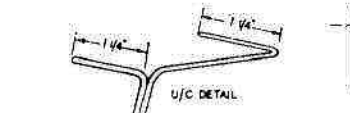

MAKE AND MEND

BY GORDON ALLEN

MOST of us at one time or another have been confronted with damage to our models on the flying field. Nobody knows better than the writer how tiresome this state of affairs can be, particularly at contests, when it may be touch and go whether we finish on top. If we give up the ghost and say "It's no use, too much damage," chances of winning winged spurs are remote, apart from the fact that our prestige as aeromodellers is likely to decline in the eyes of others.

The whole point is this. If at any time damage should be encountered on the field, or, for that matter anywhere else, always remember that coolness, a little thought along intelligent lines, and a compact repair outfit will, in almost every case, reward us with a model worthy of being put into the air again.

However, in this article we are going to deal with repairs to the most vulnerable parts or components of model aircraft. Naturally they have all been tried out in practice, and have proved to be both effective and quick. I should imagine that original ideas for other repair work will be conceived from the following by the average model builder.

The Airscrew.

This perhaps is the most likely unit to be affected. If this should become fractured at the boss or spinner, thereby leaving the bush loose on the propeller shaft, then a glance at the sketch (Fig. 1) should make the repair procedure clear. On smaller machines the mere cementing of the two blades together at the fracture may be enough, but on the bigger jobs extra precautions must be taken. Two methods are shown, the second, I think, being better than the first, although taking a little more time. Taking Fig. 1A first.

When the two blades have been cemented together, having properly located them about the bush on the shaft, and also making sure that a neat joint has been made, two small holes are drilled each side of the boss and at right angles to the crack. If by drilling the boss, the roots of the blades themselves have been caught then ignore this until later. The size of the drill employed does not matter, so long as the resulting holes provide a hard push-in fit for dowelling of about $3/32$ in. dia. The latter can be fashioned from matchstick if required in a hurry. This pegging is then pushed into place, having first applied cement to the holes. When dry, it is trimmed and sanded to the boss contour. Any other holes are filled in with plastic balsa and sanded.

Taking Fig. 1b.

The same procedure is adopted as in the first case except that all drilling is left until later on. Two flat faces are made on the boss at each side of, and normal to, the fracture, by cutting away two small segments. To restore the boss to its normal circular shape, two pieces of hard balsa are cemented to these faces and shaved. They can then be pegged as before, using smaller dowels as shown.

It may happen, however, that only one blade is fractured. Fig. 2 shows a quick method of effecting a repair.

The breakage is cemented and jointed. When set, two shallow channels are cut about $1/4$ in. wide, at right angles to the crack, one on each face of the blade. Care must be taken to see that the channels are not "back to back." Two flat pieces of hard balsa are then inlaid (using cement) and, when set, are sanded down to the

faces of the blade. In this instance, the airscrew will have to be rebalanced by gradually adding weight near the tip of the opposite blade. This can be done by pasting layers of tissue into place. As indicated earlier, this is not only a very quick, but strong method.

Undercarriages.

As shown in Fig. 3A, the repair of ordinary undercart fractures follows the same principle as that utilised for broken airscrew blades. A binding of tape or twine can be used to good effect here. If twine is used the binding should be widely spaced and then cemented.

Should any soldering break apart on the undercart fixing, a temporary but trustworthy repair is to flood the joint with cement, binding it tightly with gummed brown paper before the glue has set. The paper should be cut into $1/4$ in. wide strips.

If a wheel comes away from the axle, a small cardboard washer pushed on the end of the latter and cemented will suffice to retain it. (See Fig. 3B.)

Fuselages.

Damage to fuselages presents the hardest problem, but not one, however, which cannot be solved with a little ingenuity. The replacement of uprights or spacers is quite easy of course, providing enough tissue is neatly cut away to give access to the faulty member.

Take the case of a broken longeron. The damaged part is cut away at the junctions of the two adjoining uprights (see Fig. 4). A *new* piece is then inserted, which should be a neat fit, and cemented. Four small corner pieces or gussets, cut from $1/16$ in. sheet, are then cemented snugly into the corners. When set the fuselage can be patched with tissue. Should the fracture occur on a curved part of the longeron, then the same procedure is adopted with the exception that the new piece will have to be cut to shape from sheet.

Fig. 5 indicates two methods of repairing damage to motor peg side-plates, caused by the peg being pulled out of location by the strain of the rubber motor. Fig. 3A, representing a temporary measure only, shows a piece of $1/16$ in. sheet, made by cross-graining and laminating $1/16$ in. sheet, let into pre-cut notches in the longerons. The grooves to take the peg are cut before the plates are fixed. Gussets are added for additional support.

For permanent repair, a similar procedure is carried out. A piece of thin plywood, however, is added *between* the laminations of balsa, and the holes for the pegs are drilled *after* the plates have been fitted.

Damage of the type just mentioned is often caused by rubber breakage, the motor (or what is left of it!) bunching in a seemingly hopeless tangle in the rear of the fuselage. It is the releasing of this partly wound motor that often causes a lot more damage. Here is a method to overcome all that pulling, snatching and twisting which is generally required to free the broken power unit.

First of all, the broken end must be found and guided through the nearest side-bay of the fuselage. This is then clipped firmly in the jaws of a *strong* Bulldog clip (the type used to hold large files together). A weight sufficient to extend the motor is fixed to the holes at the ends of the clip levers. Holding the fuselage on its side, the motor can be run out merely by releasing the weighted clip. Incidentally any other type of clamp will serve the purpose.

A number of serious accidents are caused by the strain of the motor pulling the winding hook away from the

chuck jaws of the winder. Fig. 6 shows a method whereby this danger can be completely eliminated.

Wings.

Repair work to leading and trailing edges of wings and tail surfaces follows on the lines of longeron mending. The damaged section is cut away, making the cuts against the sides of the two nearest ribs. A new piece is inserted, gusseted and then shaped to the rest of the section. Severe wing-tip damage is often more quickly rectified by cutting away the whole tip and, as a temporary measure, fixing a new one by means of a thin

piece of correctly shaped balsa or substitute. This can then be strengthened by means of ties as shown in Fig. 7.

A cracked leading or trailing edge can be strengthened sufficiently merely by cementing a narrow strip of millimetre ply on the *inside* of the section and, of course, directly over the fracture.

For speed, all tissue patching on the field should be done by first cutting the tissue to the correct shape (a pair of nail scissors comes in handy here), leaving a good overlap all round, and applying it solely by means of dope.

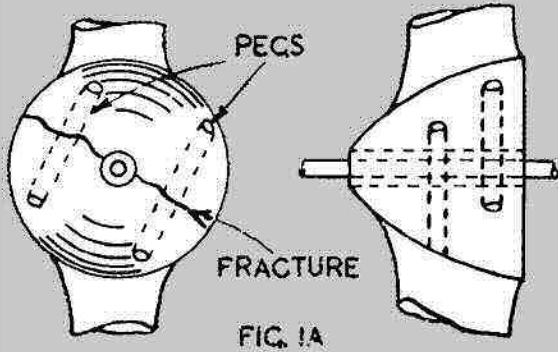

FIG. 1A

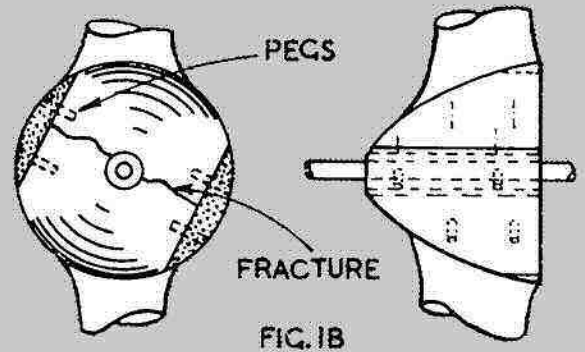

FIG. 1B

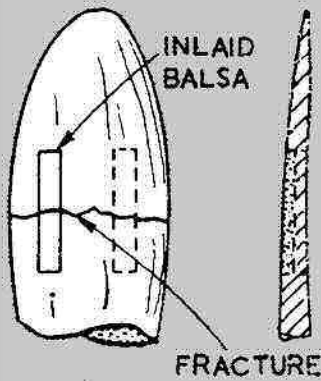

FIG. 2

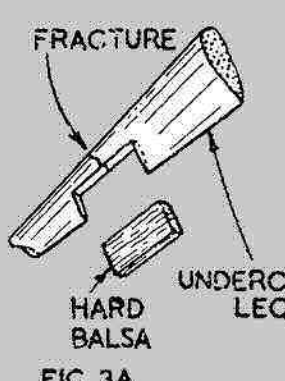

FIG. 3A

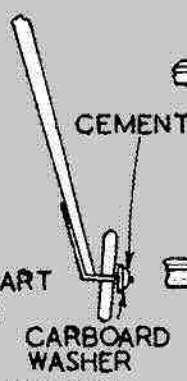

FIG. 3B

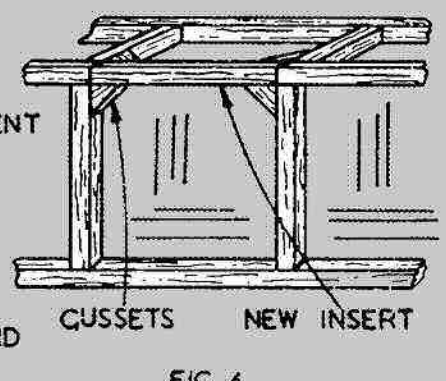

FIG. 4

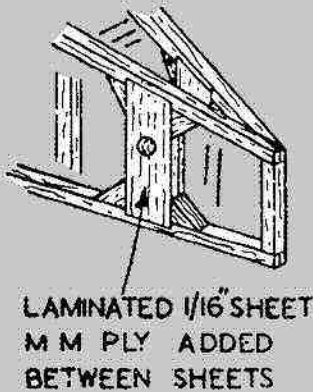

FIG. 5

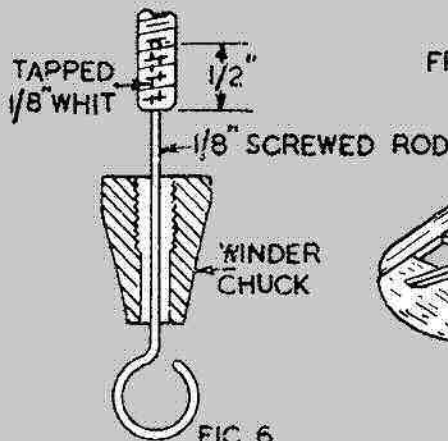

FIG. 6

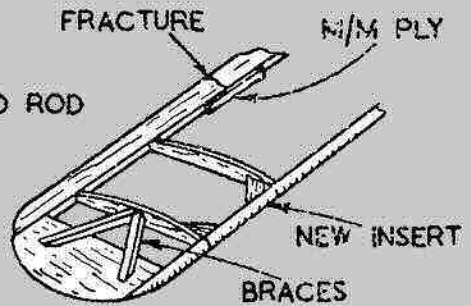
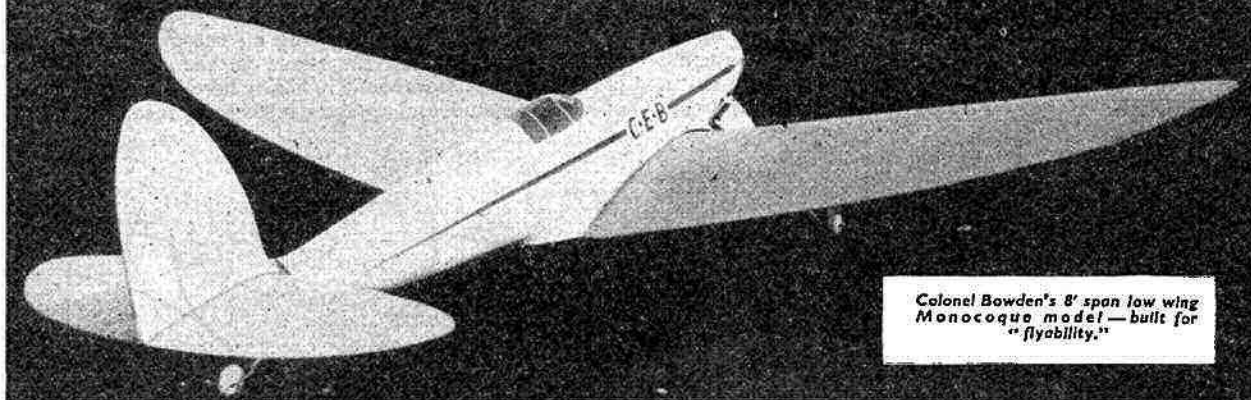

FIG. 7

Petrol Vapour

By "C. E. B."



Colonel Bowden's 8' span low wing
Monocoque model—built for
"flyability."

The Semi-Scale Model Designed for Flyability.

I suppose the average newcomer to petrolleering wants to produce for his first model, a beautiful scale of a "Spitfire," "Hurricane," or some such machine. He would be wiser to start off with a really simple "Slabsider" and learn all about it.

After all, the "Spitfire" pilot learns to fly on a simple little trainer before he splits around on his super fighter.

When the beginner has passed the simple model stage, something scalyish may be attempted, but designed primarily for flyability, and where looks fall foul of reliable flying performance, looks should lose.

A real scale model will almost always lose on certain points:—not enough dihedral, tail too small, wing area often too small, and undercarriage *always* too far back, resulting in broken props.

To my mind flying is the thing and looks come second. I am all for packing in as many good-looking features as possible but I want to see my model in the air and keep on going into the air, without constant troubles.

I know of very few genuine scale models that really do this. But cheer up you scale fiends—there are some that do!

In addition it is rather fun to design something that is your own design and not just a copy of someone else's, although I admit there is a great satisfaction and skill in producing a real flying scale model.

Above is a low-wing model of mine that looks moderately like the real thing, and yet has been designed for use. It has an elliptical wing of 8 ft. span and a 16 in. chord, and the fuselage is a balsa planked monocoque affair. The wing is made in two halves and is held to the fuselage by two white elastic straps underneath—the sort of flat elastic that "she" uses for her garters!

The engine is on a detachable knock-off mount held to the fuselage by rubber bands, and the tailplane and fin are also detachable and held in position by rubber bands, and yet the whole outfit does not look at all bad.

The undercarriage is the main blot on the landscape. It is detachable but is placed well forward to help landings. It would look much nicer if the legs protruded from the wings, but "flyability" would suffer for the wheels would not be far enough forward of the C.G. to prevent nose-overs on rough ground, or if the model did

not come into land after a very flat glide. So the undercarriage had to go forward!

Incidentally, model low-wings when properly adjusted, glide beautifully flat, and float delightfully, especially aerodynamically clean specimens like this model.

A large low-wing forms a nice cushion of air as it nears the ground just prior to landing, and an 8ft. span elliptical wing with a 16½ in. central chord provides a really hefty lift.

Carrying the Flight Battery.

For some reason or other nearly everyone installs their flight battery inside the fuselage. I always sling mine below the fuselage, or in the case of a low-wing machine, below the wing.

One can check up quickly on connections between flights, or change the battery without having to open doors in the fuselage, or take off the wing to uncover an opening in the top of the fuselage, in the case of a high-wing model.

Incidentally doors in the fuselage weaken it and often spoil a nice clean monocoque model.

If a battery is slung under the fuselage (or below the wing if a low-wing model), in a carrier that has been fashioned like a dummy "Lamblin" type radiator, in my opinion it often actually improves the appearance of a model, in addition to the advantages I have already stated.

Furthermore, the dummy radiator can be moved fore and aft to make slight alteration in trim, and it can be kept in position with rubber bands, so that if the machine does crash—and what model does not occasionally to do?—the weight of the battery will not damage the inside of the machine.

Right is my "practical low-wing monocoque model" which is fitted with a dummy radiator slung below the wing.

In this "radiator," which has a cooling grill at the front for the sake of appearance, are housed the flight time clock and the battery.

Rotted Fabric on old Models.

Can anyone, versed in the peculiarities of silk and dope, explain why some silk doped covering becomes rotten on old models before other silk that has been put on at an earlier date?

When I was on leave recently I dug out some old

models just to have a look at them. I found one 8 ft. span low-wing model that I had covered way back in 1934. The covering on this model is still quite serviceable, whereas the covering of my old record holder, "Blue Dragon," also built in 1934, is quite rotten and splits very easily. Even worse is the covering on a model I built in 1936. This has become completely brittle and a gentle touch damages it. I should much like to know what the answer is because it is extremely annoying to have to re-cover otherwise perfectly serviceable models. It is both expensive and a waste of time.

Now you silk and dope-experts, it is up to you to put us wise for the future!

By the way, I was intrigued to find what appeared to be beads of Mediterranean sea water still inside the wings of a flying boat that I had last flown at Gibraltar in 1938!

I have a pre-war 7 ft. 6 in. span German-built soarer, which is covered with a cotton fabric, doped and then painted. It is probably a little heavier than the silk that we have used to cover our petrol models with in this country, but it seems that we might find this type of German covering cheaper and more durable for larger models.

I have personally never used anything other than silk for a petrol model, nor have I seen anyone else in this country use other coverings. It would be interesting to hear from any reader who has tried out linen as a covering. I think we can rule out bamboo paper, as being far too prone to damage. I have used it to cover a monocoque fuselage, but do not like it, except on very small models, as it does not bind the balsa planks together where highly stressed parts come—such as tubes for undercarriages, etc.

Baby Batteries.

I mentioned in my last "Petrol Vapour" the aeromodeller's need for a reliable baby accumulator to be placed on the market at a cheap price, and in a strong moulded case, for we know from experiments that the baby accumulator is a success, less wasteful, and superior to a flash lamp battery. I see that the Americans have just put on the market a neat little accumulator (shown on the right) which weighs 2 oz. complete with acid.

It can be charged from a car battery (or motor cycle) on the flying field between flights. Its cost of approximately 13s. 0d. seems rather high. We require these baby accumulators for not more than 5s. 0d. What about it manufacturers?

I made a remark in my last "Petrol Vapour" about nickel-iron batteries. Since then I have seen an experiment carried out with a baby battery of this type and it was not successful. The tiny battery would not keep a model engine running, whereas we know from our experiments that the ordinary lead-plated type is most successful. I have also made some enquiries on the subject, as the idea of a baby accumulator that cannot be harmed by shorting and general abuse seems alluring. The trouble of the nickel-iron battery is that the internal resistance is much higher than that of the lead-acid type.

When the charging rate falls on a car, down goes the light. One has to keep the charging rate high all the time. On the baby battery, for our use, we cannot keep charging while the model flies! It therefore rather looks as if this type of battery will not be as successful for our purposes as the normal lead-acid type although the latter is more easily damaged.

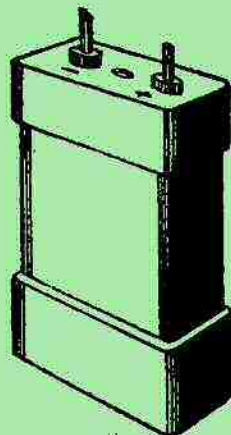

The American 2 oz. baby accumulator, commercially produced.

The Author's method of carrying the flight battery and timer clock in a dummy radiator slung below the wing.



A HORIZONTAL SINGLE-CYLINDER ENGINE

BY LAWRENCE · H · SPAREY • (PATENT PENDING)

AS one who has had a fair amount of experience of small petrol engines and the model aeroplanes which fly them, it has gradually been borne upon me that there exists no design of engine which is ideal in all respects, or that will accommodate itself to any type of aeroplane lay-out or type of aircraft. The reason is, I think, that however much it may be claimed to the contrary, no small engine has been *really* designed with all the factors in mind, but each has been a follower of some orthodox layout, with a few modifications of details sufficient to differentiate it from its fellows, and to give basis to the claim that it is indeed a model aircraft engine.

Petrol engines for model aircraft, as we understand the term to-day, are comparative late comers, and for this reason alone it is natural that they should have followed the lines already laid down by usage. The real forerunner of all miniature petrol engines is, of course, the motor-cycle engine, as being the nearest in size and simplicity. This ancestry is, indeed, evident at the nearest glance, and almost all model *aircraft* engines might easily be classified as model *motor-cycle* engines, without causing any comment.

These strongly marked hereditary traits are responsible for almost all the inconveniences and compromises from which model aero engines have suffered, and have given rise to the controversies—such as that between the supporters of the “upright” and the “inverted” engine—as well as to such features as the detachable and reversible carburetter.

The engine design which I am about to describe is a serious attempt to evolve an engine which will suffer from none of the inconveniences so far endured, and which will, besides, have additional features, inherent in the design, especially adapted for model aircraft use.

That the outcome has presented me with a most unorthodox layout is of no concern to me, for having once recognised what was the aim, I have followed the advice of the philosopher John Stuart Mill, that it is one's first duty to follow the intellect to whatever conclusions it may lead.

The first step in the evolution of the design was to find a layout which would overcome the necessity for reversing the engine to fit the needs of the particular aeroplane which one was contemplating. It required but little thought to see that the only way in which this could be accomplished was by placing the engine upon its side, so that the cylinder protruded sideways. In this way, the crankshaft occupied a central position whichever way the engine was laid; thus the engine might always be run as conveniently one way up as another, and that great bugbear—reversibility—was overcome.

It is, of course, no new thing to run petrol engines in a horizontal position; in fact, it is the normal placing for opposed twin-cylinder engines, of which there have been some good commercial examples, used chiefly in motor-cycles and light cars. There is, in fact, no earthly reason why any normal reversible engine now upon the market should not be run in any desired position, provided that the petrol tank can be moved to the required angle. The chief drawback is that the arrangement is most unsymmetrical, as it would mean that almost all of the engine would be lying upon one side of the aeroplane, and that the controls would be in most inaccessible places.

Having drawn the cylinder horizontally upon the paper, I must confess that I was presented with a most unpromising start, and my next job was to render the layout more symmetrical: in other words, something must be found to counterbalance the engine cylinder. The only other thing of like size which would serve was, of course, the petrol tank; so I proceeded to draw this as if affixed to the opposite side of the crankcase. Now the engine began to assume some symmetrical semblance, but still appeared unbalanced. The addition of dummy fins to the end of the petrol tank—to match those upon the cylinder itself—overcame this trouble, and the engine began to look like a very neat twin-cylinder design.

At this point, several difficulties became apparent. In the first place, the petrol tank was in a position most unfavourable for delivery of the petrol to any type of carburetter commonly used. Also, the intake to the crankcase presented a difficulty, in so far as the tank was in the wrong position for supply to the simple, cylinder-port type of valve, and also to the rotary-disc type of valve. Possibly some arrangement of either of these types could have been used if I had entertained *gravity feed* to the carburetter, but this system is most unsuitable for model aircraft work, as the pressure of petrol varies with its level in the tank, and the engine is apt to become flooded with neat petrol when the plane alights at some distance from the operator, and must, therefore, stand unattended for some considerable time.

Obviously, some new arrangement was called for, and, after some considerable thought, the carburetter was placed vertically upon the top of the crankcase, and a new (to me) rotary sleeve valve was evolved. It will be understood, of course, that this valve has not yet been tried out by me in practice, but I have studied it from all angles, and can see no reason why it should not be a most efficient type. I will explain this valve more fully later on in this article. In any case, I have an alternative cup-valve which embodies a similar principle, but may have some additional advantages.

I was now presented with a layout something similar to that shown in Fig. 1. Here it will be seen that the engine lies horizontally, and that the cylinder is offset by the petrol tank lying in opposition. The intake-tube of the carburetter may be seen protruding vertically from the top of the crankcase, and looking, unfortunately, something like the funnel of Stephenson's “Rocket.” The carburetter control screw protrudes horizontally from the side of the intake-tube, while the petrol is drawn by air suction, in the usual way, through a curved tube from the tank.

Before proceeding to describe the engine in more detail, I would ask readers to consider the convenience of this layout when fitted into a normal model aeroplane. First, we have a most sturdy and homogeneous design, free from all the flimsily suspended petrol tanks with which we have become familiar. Secondly, the engine may be mounted into the airframe in a high, middle, or low position without any alteration being necessary. These two points, in themselves, would merit a serious consideration of the design.

In Fig. 1 will be seen a large dotted circle which I intend shall represent the cross-section of an aeroplane fuselage at the point where the engine will be situated. The most obvious feature is, of course, that the cooling fins of the cylinder protrude from the side of the aero-

plane in a manner which will ensure good cooling. The cylinder head could be housed in a scoop-like fairing open to the slipstream, and in harmony with the lines of the modern petrol-driven plane. Almost as important, however, is the fact that the plug is in a most accessible position, and may be removed or replaced without removing the engine cowling, or disturbing any other fixture.

On the other side of the aeroplane protrudes the finned end of the petrol tank, which will, of course, be provided with a suitable filler hole and cap, possibly counterbored into the finned portion. The end of the petrol tank might also be enclosed in a fairing similar to that for the cylinder head, for appearance's sake. Note how accessible would be the filler to the petrol tank; how clear of all internal parts of the fuselage, and of the rubber-covered ignition wires which so rapidly deteriorate under the constant drenchings with surplus petrol. When the tank is accidentally filled to overflowing (as it always is) the surplus petrol simply spills upon the ground. I think that most experienced petrol-model flyers will agree with me that the easy filling of the tank, without the necessity of half dismantling the front of the fuselage, and the freedom from accidental swamping with petrol, would be "worth the money."

In the same drawing, Fig. 1, will be seen the exhaust pipe, and it will be appreciated that this component is extremely well placed to disperse the fumes away from the internal structure of the aeroplane. Also, a reason-

ably short exhaust pipe may be used, and the necessity for extending the pipe to limits which may adversely affect the running of the engine is avoided. Generally speaking, the disposal of the exhaust gases is very poorly provided for in the majority of small aero engines.

Coming to the carburetter, some good points also automatically resolve themselves. The problem of choking the air intake-tube with the finger, for purposes of easy starting, is often a most difficult—not to say, dangerous—one with the majority of small engines of the orthodox layout. Most often one must extend the intake tube with a length of rubber tubing, so that a convenient inlet may be had when the cowling is in position. Although this extension of the inlet tube would seem to have but little effect upon the running of the engine, it is, at best, a makeshift expedient, and is not in accord with engineering principles. In the present layout, however, the top of the inlet tube will protrude from the top of the fuselage in a most convenient manner, and I can imagine no better location for it from this point of view. Should the engine be placed very low down in the fuselage, the inlet tube, as I have shown it, would be too short to protrude from the fuselage top. The design does, nevertheless, provide for a simple type of telescopic inlet tube, one portion of which may be a tight slide fit within the other. Thus, the desirable features may be retained irrespective of the engine position.

In Figs. 1 and 3 the extended carburetter control

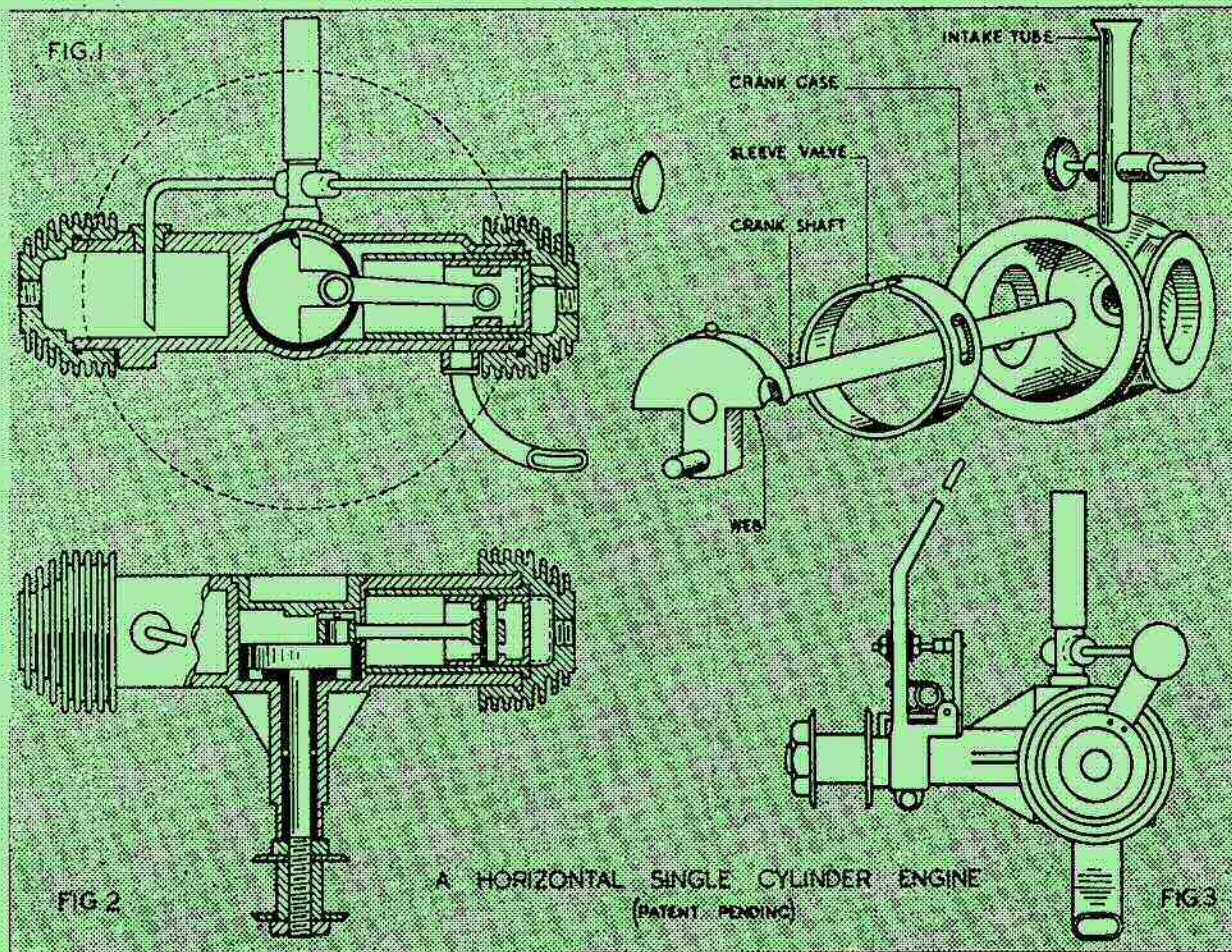

needle will be noted. This is arranged to be supported in a rigid manner upon the engine itself, so that the control knob may protrude from the fuselage side. It will be seen that the control rod has been slightly back-set, so that the control knob may protrude slightly behind and above the cylinder head. This is another inherent point of convenience in the design. It will be understood, is course, that some form of clip will be provided to lock the needle into its required position when the engine is running.

As the petrol tank lies along the same horizontal axis as the cylinder and carburetter, the tilting of the aeroplane in climbing and sinking flight would affect the petrol level to a minimum extent; in fact, any appreciable alteration in the petrol level or pressure would be non-existent. When banking, however, the level of the petrol would be altered to a somewhat greater degree, but I doubt if sufficient alteration would take place to make any difference to the running of the engine. If necessary, this effect could be nullified by fitting a sunken well at the bottom of the tank, into which the end of the delivery pipe could be placed. This well would hold a sufficient supply of petrol to ensure that the engine did not stall during the brief periods in which a model plane is in the banking attitude. It must be remembered that climbing or descending occupies a major part of a model aeroplane's flight, and a variation of petrol level *longitudinally* is of more importance than a variation *laterally*.

Fig. 3 shows a side elevation of the engine, looking from the cylinder end, and will serve to show that a simple bending back of the ignition control lever to clear the carburetter is all that is necessary to ensure that this control lies well away from the spinning propeller. The arrangement allows for the tip of the control lever to protrude from a slot cut into the fuselage top, so that all the controls may be operated from outside the machine, while the engine remains almost totally enclosed.

Such is a brief outline of the advantages which I claim for this unorthodox design, and I ask readers to consider what a boon such an engine would be for the too often neglected scale modeller. Most devotees to this most interesting branch of the pastime will agree that it is when it comes to fitting the engine in a manner in keeping with the requirements that the headaches begin. More often than not, a virtue is made of necessity, and the design openly makes no pretence to conform to full-size appearance, and the engine is housed and hidden up as best may be. The present engine, with its inconspicuous controls and neatly cowed cylinder heads, would lie just excellently into almost any scale design. Also, with a few simple modifications to the length of the intake tube, it is almost the only design of engine which could conveniently and neatly be housed in the *wings* of a model aeroplane.

Coming to the actual mechanical problems of the design, no great difficulties exist, above those always encountered in small engines. This being so, the only real interest lies in the rotary sleeve inlet valve to the crankcase. As readers are aware, I am a great lover of the rotary disc type of inlet valve, such as was shown in a previous design of mine. This arrangement of inlet provides for a rotating disc, which lies flat against one end of the crankcase, and which derives its motion from a direct coupling to the crankshaft. The rotating disc has a bean-shaped hole cut into it, so placed that it periodically uncovers a hole in the crankcase end; this hole being the internal end of the carburetter intake tube. Suitable timing ensures that the valve uncovers the inlet hole at the right moment; that is, when the

crankcase conditions are those of suction. This, simply, is the rotary disc inlet valve.

Such a valve working against the crankcase end would, as I have already pointed out, have been unsuitable with the present layout, but I was loth to abandon the rotary valve principle, as I consider it to be the most efficient and long-wearing type. This brings us to the isometric drawing of the valve gear in exploded view, which I have evolved to fit the case.

Here we see the whole assembly, consisting of the crankcase (with down-draught carburetter), the sleeve valve, and the crankshaft. As will be seen, the intake tube is inserted vertically into the crankcase, and, although it could not be shown in the drawing, it will be understood that the lower end of this tube penetrates the wall of the crankcase, and is flush with the inside. This provides a direct inlet into the crankcase for the gas.

Next in order comes the rotary-sleeve valve, which consists of a short length of tube which is a good running fit within the crankcase. The sleeve is driven by the crankshaft, which has a small peg inserted into it to engage with a suitable slot in the sleeve. The whole web of the crankshaft partially enters the sleeve, leaving the big-end journal protruding so that the connecting rod may be free to operate. In the sleeve may be seen a rounded slot, which serves as a valve, and it will be arranged for this slot to register exactly with the inlet opening in the crankcase when assembled. It will thus be obvious that when the sleeve is rotated the slot will uncover the inlet port at predetermined intervals in relationship to the movement of other parts of the engine. Also, the length of time that the port remains uncovered may be determined by the length of the hole in the sleeve. These matters constitute the inlet valve timing, and the latitude of timing and overlap which the rotary disc or sleeve valve allows constitutes one of the main points in its favour. It will be seen that a small portion of the crankshaft web has been cut away, so that the inlet slot in the valve might not be partially covered when the web is inserted into the sleeve.

In addition, the rotary valve would be well lubricated, and would provide a large closed area when the valve is shut, and leakage from the crankcase would be almost impossible. Further, the arrangement would be most easy to make, and a good fit might be obtained without the necessity for a scraped fit of the flat surfaces which the disc type valve may involve. As shown in the drawing, I believe that there might be a danger of the thin end of the sleeve wearing a groove in the end wall of the crankcase, so, to provide against this, the actual experimental engine will have a slightly modified type of sleeve valve. This will take the form of a shallow cup, rather than that of a plain sleeve, and might best be likened to a thickened edition of a cocoa tin lid, with a circular hole cut into the middle. This hole will run on the boss of the main bearing, which protrudes into the crankcase, so that the rotary valve bears not only upon the walls of the crankcase but upon the end as well. This should be an almost ideal arrangement.

I am fully aware that all one's own geese are apt to be swans, and I have tried to survey the design objectively in an endeavour to discover any vital weakness. The first point of criticism would seem to be the liability for the petrol level to alter *laterally* when the aeroplane is banking, and I have, I think, dealt with this point. Coupled with this matter is the fact that the engine becomes unbalanced in weight as the petrol lever becomes lower. I have ascertained that the weight of

Continued on page 375

THE ASSOCIATION OF BRITISH AEROMODELLERS.



*“To Promote, Encourage, Develop, Organize,
and Protect the Model Aeroplane Movement
throughout the United Kingdom.”*

THESE are the paramount aims and objects of this Association, the formation of which marks an entirely new chapter in the history of Aeromodelling.

Many members have already enrolled, thousands more are expected and it is anticipated that the final Membership will be counted in tens of thousands. Thus being truly representative of the Aeromodelling movement in the United Kingdom.

Valuable donations have been received from many prominent personalities and organisations and a sound financial position is already assured. This is essential if the aims and ideals of the Association are to be attained, as they most surely will be.

Individual Sections

Separate sections of the Association have been formed—there are nine already. Further sections may be formed at the discretion of the Council. A Representative and Committee for each Section will be elected at the next Council meeting.

- | | | |
|---|---|--|
| Rubber Driven Duration Models. | Power Driven Models of any type. | Rubber Driven Senplanes and Flying boats. |
| Rubber Driven Flying Scale Models. | Motive Power Plants of any type other than rubber. | Experimental Models. |
| Solid Scale Models. | Sailplanes. | Library. |

Membership

Membership of the Association is open to any person of any nationality. Persons of any age, resident in any part of the world, can become Associate Members.

Full Membership is open to any person (who is NOT an Associate Member) of the age of 25 years and upwards, resident in any part of the world; subject to the Council of the Association being satisfied as to that person's technical qualifications or achievements in the sphere of aeromodelling or allied or ancillary fields.

Insurance

Payment of the appropriate third party premium is automatically included in the annual subscriptions below.

Subscriptions.

- Associate Members under 25 years of age—5s. a year. Associate Members over 21 years of age—10s. 6d. a year.
Full Members—over 25 years of age—£1 1s. 0d. a year.

Why the Association was formed

The Association has been formed in order to give Aeromodellers everywhere an opportunity of belonging to an organisation that will look after their interests in every conceivable way :—

It will seek to regulate, encourage and foster the building and flying of model aircraft of every description ; promote competitions, exhibitions and scholarships and foster research and education ; give sound advice and assistance to members on all matters relating to their problems ; promote or oppose any acts or proceedings affecting the interests of the movement ; promote Bills in Parliament ; establish and support social clubs for aeromodellers, and co-operate with all other organisations likely to advance the interests of aeromodelling and members of the Association.

How it affects You

If you are in the slightest way interested in aeromodelling it is to your own personal advantage to join the A.B.A., either as an Associate or Full Member, and to induce as many of your friends and acquaintances similarly inclined to join with you.

Unity is strength. With a united and powerful membership of all aeromodellers, you will have a decisive voice in all matters affecting your interests and those of the movement in which you seek your pleasure and your profit.

Every Full Member will enjoy the right of a voice in the affairs of the Association, and will be able to exercise the privilege of voting and election to any office.

A FULL-TIME PAID SECRETARY WILL SHORTLY BE APPOINTED WITH ADEQUATE OFFICE ACCOMMODATION AND STAFF.

The Future

The Association realises to the full the great future that lies ahead for those interested in Aeromodelling. The aims and objects have been framed with a broad vision and an elasticity that will permit of the greatest possible post-war expansion on sound, effective and efficient lines.

But the future depends entirely on YOU. It is YOUR support, YOUR help and YOUR guidance that is essential. Without it nothing can be done ; with it, everything.

Remember ! Britain MUST lead the world in Model Aeronautics. There is still a lot to be done to catch up with other countries.

Upon receipt of the completed form below, the Secretary will forward you without delay full details of the Association together with the necessary Membership form.

MEMBERSHIP OF ANY OTHER ORGANISATION DOES NOT PREVENT YOU FROM JOINING THE A.B.A.

TO THE SECRETARY, THE A.B.A., 84, HILLWAY, HIGHGATE, N.6. (Temp. Office)

Please send me full details of the Association together with Membership Form.

**BLOCK
LETTERS
PLEASE**

NAME.....

ADDRESS

Readers' Letters

The Editor does not hold himself responsible for the views expressed by correspondents. The names and addresses of the writers, not necessarily for publication, must in all cases accompany letters.

DEAR SIR,

For many years past, I have been an interested reader and enthusiastic supporter of your journal. Noticing recently that you had inaugurated a "Readers' Letters" section, I was prompted to enlist your help, and possibly, at the risk of starting a controversy, to get the following questions settled to my satisfaction.

In Mr. R. H. Warring's book "Airscrews for the Aeromodeller," chapter IV, page 29, he states, quote:—

"With these figures, and assuming V for climb = 16 f.p.s., V for cruise = 20 f.p.s., and V for end of cruise = 24 f.p.s., we are now able to calculate "J" for 3 cases."

While not wishing to upset Mr. Warring by contradicting this statement, it seems to me to be somewhat at variance with the well-known rule or statement of aerodynamics which says that "if the normal level flying speed of a model is increased, the model, the trim of which is not altered, will climb." Keeping this in mind, my theory of a rubber model flying under power is as follows:—

1. *Climbing*.—The model climbs as a result of an increase in forward flying speed over that required for normal horizontal flight, this increase being brought about by high initial motor thrust.

2. *Cruising*.—When this high thrust dies off, the plane assumes a horizontal or nearly horizontal altitude for a certain period, this new altitude being the result of a slackening off of flying speed to a speed more nearly approaching that required for normal level flight.

3. *End of cruise*.—Towards the end of the power run the model will begin to descend, due to the flying speed falling below that required for normal horizontal flight.

These theories are the exact opposite of Mr. Warring's, where as mentioned before, he assumes a low value of " V " for climb, a slightly higher value for cruise, and a high value for end of cruise. Why?

In chapter VI, page 50, of the same book, Mr. Warring quotes certain figures for climb, cruise and end of cruise obtained by means of an airspeed indicator fitted to the model, which bear out all his earlier assumptions and certainly put the "tin hat" on my theories. (By the way, how did Mr. Warring read the airspeed indicator when the model had reached its maximum altitude and commenced cruising? Mr. Warring's designs being noted for their efficiency, I'm sure the maximum altitude was considerable.)

To continue, perhaps the explanation lies in the fact that the climbing altitude of a model is not induced as a result of increased forward speed, but as a result of resistance of the model, causing a "nosing up" tendency, this "nosing up" effect being in proportion to the thrust developed, and causing the model to climb, even though the *climbing velocity* might be less than the average level flight velocity?

This explains the first part of Mr. Warring's statement, but it does not hold good for the "end of cruise" part, when according to him, the velocity is greatest. This means, as the thrust dies off, the velocity increases, therefore when there is no thrust there is maximum velocity. Therefore a model glides faster than it flies under power? This is the reverse of a statement by Mr. Stubb's in his book "Design of Wakefield Models," in which he says that there is a "slight decrease in speed when the model is gliding."

Another point on which I require some clarification is the statement on page 51, chapter VI, of "Airscrews for the Aeromodeller," in which Mr. Warring says that "for the airscrew to have maximum efficiency throughout flight, it would appear that we want to change the pitch from 16.8 in. at the beginning of the flight, to 26 in. at the end."

The chapter in which this statement occurs, deals entirely with the problem of variable pitch propellers with particular reference to that ever varying quantity " n ," or revolutions per second. The whole problem seems to be to get " n " constant. To do this Mr. Warring says that the ideal

arrangement would be to have the pitch governed by the torque.

Now, assume we have a 3 oz. rubber motor, wound to maximum turns, with an 18 in. diameter and say 18 in. pitch propeller on the shaft. When the propeller is released it rotates at a certain velocity, this velocity being rather high while the torque is high, and decreasing as the torque decreases. Wind up the 3 oz. of rubber again without disturbing the arrangement of strands, and substitute an 18 in. diameter, 24 in. pitch propeller. When released, the propeller will rotate fast at first, but not quite as fast as the first propeller with the finer pitch, and as before, the speed will decrease as the torque decreases.

Therefore, I say, if a variable pitch propeller is to be efficient, the pitch should be *coarse* at the beginning, to cut down revolutions under full torque, and gradually getting finer towards the end, to prevent the revolutions dropping off as the torque drops off.

Well, Mr. Editor, what do you think? I do hope you or some of your technical-minded readers will be able to straighten things out for me.

R. FLANAGAN.

Eire.

As we feel that a great deal of useful discussion will arise from Mr. Flanagan's questions and theories, we leave his answers to our "Technically-minded readers."—Ed.

DEAR SIR,

I have been extremely interested in the article "Acromodelling as an Industry," contained in the April issue of your most valuable magazine, and understand that you have no accurate information concerning "Kirksite."

This material is not as you suggest "a form of plastic," but is a zinc base alloy introduced by the firm of Morris P. Kirk & Sons, for drop hammer tools used in aircraft sheet metal forming. The material, although having a zinc base, is when sand cast of greater tensile strength and Brinell hardness than any of the die-casting alloys when cast under the same conditions.

I believe the metal is sold in the U.S.A. under the name of "Zamak 2," which is in turn marketed in this country under the name of "Mazak," and furthermore "Mazak 2" is identical with "Zamak 2."

The zinc base is of very high grade, having a purity of 99.99 per cent. The alloying ingredients are aluminium, copper and magnesium in the following proportions:—

Aluminium	3.5 to 4.5 per cent.
Copper	2.5 to 3.5 per cent.
Magnesium	0.02 to 0.10 per cent.

the addition of these elements having the effect of refining the grain.

Doubts may be raised regarding the durability of these zinc base tools when used for press or drop hammer operation, but an indication of their serviceability may be gathered from the fact that in one instance, 2,500 stainless steel exhaust manifolds in 14-gauge material have been produced from a Kirksite die.

I trust that the foregoing will be sufficient to enable you to visualise some of the workings of the Doering twins, but should you wish to delve deeper into the question of Kirksite or other zinc base alloys and their applications in production of aircraft pressings I shall be pleased to give further assistance.

I would like to take this opportunity of thanking you for the excellent matter contained in AEROMODELLER, a copy of which I now obtain regularly.

Coventry.

J. W. PETERS.

The above letter is one of the many received offering information concerning "Kirksite," fully demonstrating our Readers' keen interest. To the writers of all the unpublished letters we can do no more than say "Thank you!"

Continued on page 364.

LONGERONS & SPACERS $\frac{1}{8}$ SO Balsa OR $\frac{3}{32}$ SUBSTITUTE.



U.S. TYPE
TRANSPORT GLIDER
DESIGNED BY
A. PIERCE
SCALE: $\frac{1}{3}$ FULL SIZE.

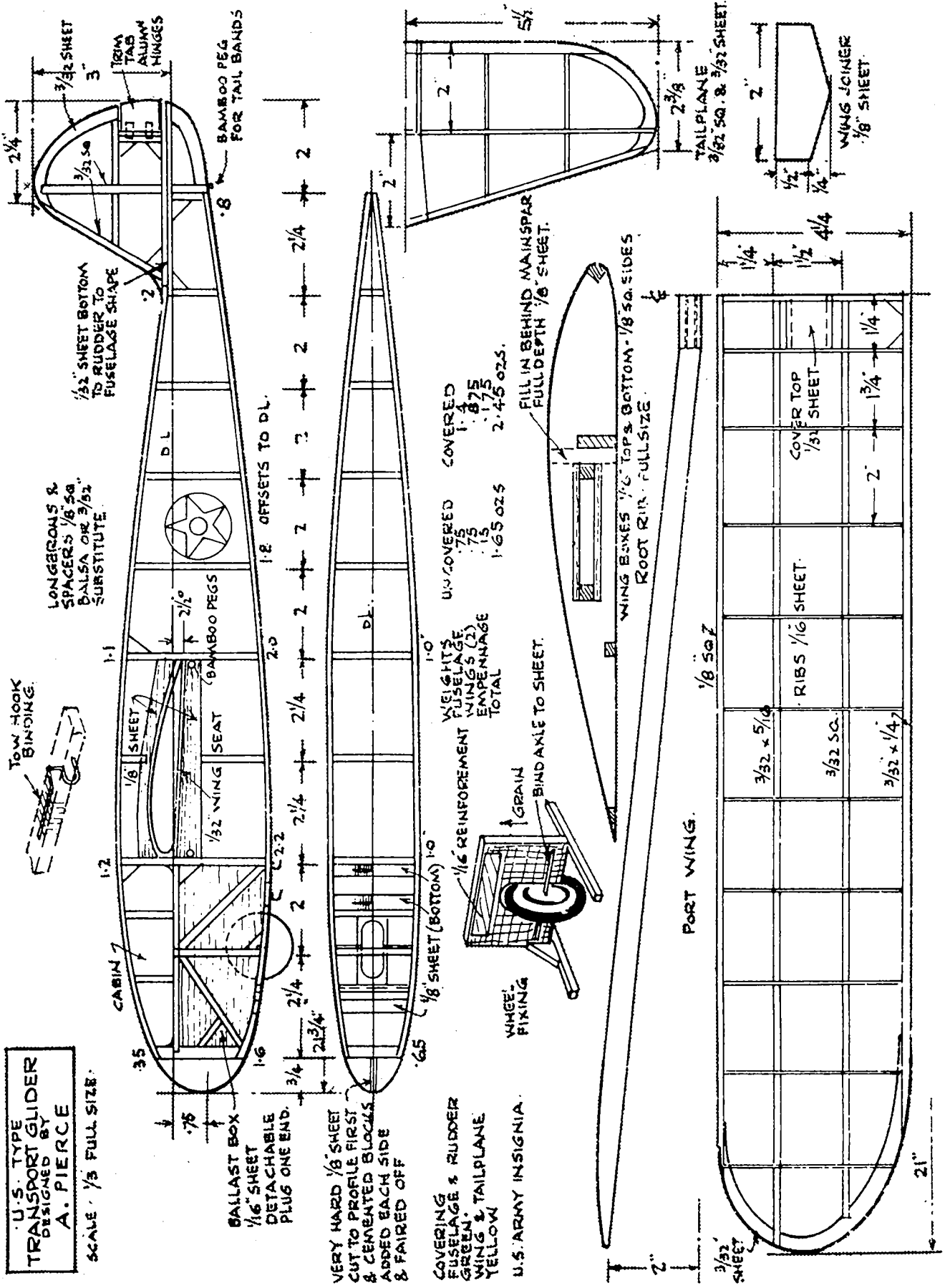

- 1-1
- 1-2
- 1-3
- 1-4
- 1-5
- 1-6
- 1-7
- 1-8
- 1-9
- 1-10
- 1-11
- 1-12
- 1-13
- 1-14
- 1-15
- 1-16
- 1-17
- 1-18
- 1-19
- 1-20
- 1-21
- 1-22
- 1-23
- 1-24
- 1-25
- 1-26
- 1-27
- 1-28
- 1-29
- 1-30
- 1-31
- 1-32
- 1-33
- 1-34
- 1-35
- 1-36
- 1-37
- 1-38
- 1-39
- 1-40
- 1-41
- 1-42
- 1-43
- 1-44
- 1-45
- 1-46
- 1-47
- 1-48
- 1-49
- 1-50
- 1-51
- 1-52
- 1-53
- 1-54
- 1-55
- 1-56
- 1-57
- 1-58
- 1-59
- 1-60
- 1-61
- 1-62
- 1-63
- 1-64
- 1-65
- 1-66
- 1-67
- 1-68
- 1-69
- 1-70
- 1-71
- 1-72
- 1-73
- 1-74
- 1-75
- 1-76
- 1-77
- 1-78
- 1-79
- 1-80
- 1-81
- 1-82
- 1-83
- 1-84
- 1-85
- 1-86
- 1-87
- 1-88
- 1-89
- 1-90
- 1-91
- 1-92
- 1-93
- 1-94
- 1-95
- 1-96
- 1-97
- 1-98
- 1-99
- 1-100

CABIN

BAMBOO SEAT

WHEEL FIXING

GRAIN BIND AXLE TO SHEET.

UNCOVERED COVERED

WEIGHTS FUSELAGE

WINGS (2) EMPENNAGE TOTAL

WHEEL FIXING

GRAIN BIND AXLE TO SHEET.

UNCOVERED COVERED

WEIGHTS FUSELAGE

WINGS (2) EMPENNAGE TOTAL

FILL IN BEHIND MAINSPAR FULL DEPTH $\frac{1}{8}$ SHEET.

WING BONES $\frac{1}{2}$ TOP & BOTTOM $\frac{1}{8}$ SO. SIDES
ROOT RIB FULL SIZE

- 1-75
- 1-76
- 1-77
- 1-78
- 1-79
- 1-80
- 1-81
- 1-82
- 1-83
- 1-84
- 1-85
- 1-86
- 1-87
- 1-88
- 1-89
- 1-90
- 1-91
- 1-92
- 1-93
- 1-94
- 1-95
- 1-96
- 1-97
- 1-98
- 1-99
- 1-100

BALLAST BOX $\frac{1}{16}$ SHEET DETACHABLE PLUG ONE END.

VERY HARD $\frac{1}{8}$ SHEET CUT TO PROFILE FIRST & CEMENTED BLOCKS ADDED EACH SIDE & FAIRED OFF

COVERING FUSELAGE & RUDDER GREEN.
WING & TAILPLANE YELLOW

U.S. ARMY INSIGNIA.

PORT WING. $\frac{1}{8}$ SO. Z

RIBS $\frac{1}{16}$ SHEET.

COVER TOP $\frac{1}{32}$ SHEET

READERS' LETTERS *continued.*

DEAR SIR,

I should like to say a few words *re* my own modelling just to show that modelling can be done even when in the Army. I came up against plenty of difficulties trying to carry on as usual. Firstly, army huts aren't exactly suitable in the matter of light for accurate work, so it was necessary to scrounge (a good army word that), some cable and connectors or a bed light. Then a building board, a friend kindly came to the rescue by making a folding board which would just fit in a suitcase I had on hand, then one of our Corporals possessed a sturdy home-made table which I was able to borrow and I was nearly set. Materials, plans, drawing instruments, etc., all went in the suitcase. But what about those long lengths of balsa (yes, I had a few), a Nissen possesses but three rafters; they were very useful to strap wood to! Gradually I collected comprehensive tackle; a vice, hammer, chisels, etc., and it was a rather amusing struggle to hide away all this surplus kit when room inspection took place in the mornings!

Owing to my board being necessarily small, my models have been limited in size to about 2 ft. span. The first one, however, met with disaster as leave intervened (pleasurably) before it was covered and someone, maybe a Royal Armoured Corps Gremlin, contrived to squash it somewhat. Solids would I thought be more suitable so I commenced a 1/72nd Whirlwind. This went much against the grain, as I have always been a duration fan, but circumstances prevailed and a good job was done. This modelling caused no little stir amongst my room mates and after some time the whole squadron would be enquiring as to the progress of certain models. Most of the lads were a little dubious about the hobby but when a few of the keener craftsmen started following my example the number of models produced grew rapidly. My time is being enjoyably spent; whether a club will materialise or not I can't really say now but am hoping for it. If it is possible with shortage of space to publish a little of this letter it would probably show some of the lads that aeromodelling in the army can be successfully accomplished.

Staffs.

G. E. OAKES.

DEAR SIR,

I mentioned in one of my articles (Petrol Vapour) that I had collected over 30 petrol engines since the early days of petrol driven model aircraft, and that after the war I intended only using those engines that were good starters, good runners and reliable to operate. I did not foresee the many requests I should have to sell my engines!

I therefore hasten to explain that this collection of engines has a substantial and historical value that would be lost if I were to part with some of them. A number of them have been modified, others have never been of much use and

never will. Finally these engines are stored away where it is difficult to get to them until after the war.

I hope that I shall not be considered a dog in the manger if I keep this "Museum" collection until I am too old to take an interest in model aeroplanes. I am hoping that my son will then want to keep this rather unique collection. These engines show in a tangible form the hopes and aspirations of many designers and the development of the model aero engine.

Preston.

C. E. BOWDEN.

DEAR SIR,

I have enclosed a drawing and MSS. of one of my rubber-driven model 'planes which you may like to publish in the AEROMODELLER. Perhaps I should mention a word or two about my aeromodelling experience before signing off. I won my first model 'plane competition when I was about eight years old, my opposition consisting of a team of enthusiastic members of the Royal Aircraft Establishments Club. I built and flew my first petrol machine in 1933; it was powered by a 15 c.c. four-stroke borrowed from my father's model speed-boat. In 1934 I entered my third petrol 'plane in the Sir John Shelley Cup race, or should I say meeting! I was fifth (my young brother was second!). It may interest Dr. Forster to know that all of these early machines had undercarriages made from light alloy tubing (telescopic) and steel rod—these undercarriages could and often did stand considerable abuse. The airscrews were invariably made from sheet metal, likewise engine bearers and many small fittings. The engines were usually started by means of a drill brace. Most of these early machines were either 10 ft. or 12 ft. span—the size and ability of the engines demanded these generous dimensions. Though later I built a 13 ft. 6 in. span model driven by a 30 c.c. two-stroke fitted with an 18 in. metal airscrew and this was followed by a model measuring 16 ft. 6 in. span, built in 1939, this machine was built with the definite object in view of obtaining controlled flights. The manoeuvres of the flight were decided before the machines took off by fitting an appropriate record to an instrument in the model. The record was to resemble a musical box disc. The advent of the war however prevented me getting that far with the venture. The machine was flown, however. Some years ago I did some experimenting with gliders that were launched from a kite—both day and night operations were carried out, needless to say the night flying caused considerable excitement among the residents who were unfortunate enough to live handy to our flying field.

And now I am back to my first loves, gliders and rubber-driven models. If any of the above should interest your readers I will supply details to the best of my ability.

Hants.

G. W. W. HARRIS.

G. W. W. Harris with Prometheus III at Falrey's in 1934. In the background is a machine built by his brother which won the Sir John Shelley Cup meeting that year.

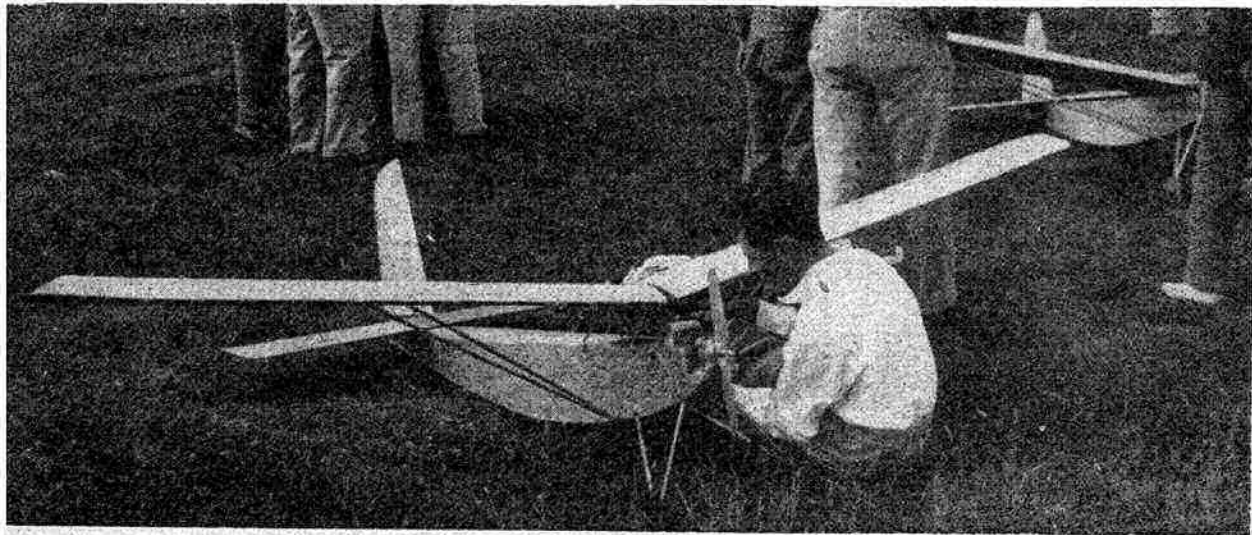

QUEER KITES

 BY
 "D. B. M."

ONE bright morning in early summer, some seventeen years ago, the inhabitants of a pretty Somerset hamlet were distracted from their peaceful tasks by a peculiar buzzing sound, rather like that of an infuriated bluebottle in an empty matchbox. This sound trickled over the skyline of trees in increasing volume until there suddenly appeared overhead a strange species of aeroplane, the shape of which caused excited comment among the villagers.

"Look 'ee yur, Fred, there be a big bat thing flyin' round!" exclaimed one. "Seems to I 'er 've lost 'er back part," said a more observant member of the community, while the matter was finally summed up by the local postman's remark, "Must be one o' they new-fangled things they do make to Yeovil."

The latter assumption, incidentally, was quite correct, for the queer aircraft then passing over them was the Westland-Hill Pterodactyl Mk. IA tailless experimental monoplane, out on a test flight from the Westland aerodrome at Yeovil. And, from that day onwards, right up to the appearance of the final Rolls-engined Pterodactyl Mk. V tailless fighter sesquiplane, the Westland-Hill series of experimental machines was known to Somerset villagers as "bats."

The Westland Aircraft organisation has, however, produced other strange and unconventional aircraft, some of which, although seemingly unsuccessful efforts at the time, paved the way to the design of aeroplanes which established world-wide reputations.

Seaplanes and autogiros, bombers and light sporting 'planes, air-liners and torpedo 'planes, four-gun fighters and tailless research machines—all have been built by Westland Aircraft, the story of whose growth, from a small hut in 1916 to a vast organisation in 1944, is told in thrilling detail in a new "Harborough" publication, "The Book of Westland Aircraft."

This volume is of absorbing interest and, although it deals primarily, in chronological order, with every type of aeroplane constructed by Westland, a profusely illustrated sixteen-page introduction covers the historical side of the Company's inception and expansion.

The bulk of the book, dealing with the various aircraft, is divided into two sections, the first concerning machines solely of Westland design and construction, with a

second part devoted to types produced by the firm, but not of their design. In the first section each machine is illustrated by two photographs and a 1/72 scale three-view drawing and its power, construction, equipment, performance, etc., is described in a neat specification, together with notes of its history. The second section covering the Westland-built aircraft, is similarly arranged, but here the three-view drawings are of a somewhat smaller scale.

A vast amount of research and investigation has obviously been entailed in securing authentic information, drawings and photographs of such a range of machines, some of them built and flown over a quarter of a century ago! As a work of reference "The Book of Westland Aircraft" is definitely without equal of its kind, containing, as it does, so much hitherto unpublished information. For the convenience of intending readers we append a classified list of the aircraft featured in "The Book of Westland Aircraft":—

Fighters

Whirlwind, F. 7 30 Biplane, C.O.W. Gun Fighter, Interceptor, Wizard, Westbury, Weasel, Wagtail, Supermarine Spitfire.

General Purpose

Lysander, P.V. 7 (Torpedo), Wallace, P.V. 3 (Torpedo), Wapiti, Walrus, Hawker Hector, D.H. 9A,

Light Aeroplanes

Widgeon Mk. III, Woodpigeon, Widgeon Mk. I and Mk. II, Hندی Heck.

Seaplanes

N. 16 and N. 17, Short "225," Short Canton Unne.

Commercial Types

Westland IV and Wessex, Dreadnought Postal, Six-seat Limousine, Limousine.

Bombers

Witch, Yeovil, Vickers Vimy, D.H. 9, D.H. 4, Sopwith 1½ Strutter.

Research Types

C.L. 20 Autogiro, C. 29 Autogiro, Pterodactyl Mk. V, Pterodactyl Mk. IV, Pterodactyl Mk. IA and Mk. IB.

"The Book of Westland Aircraft," compiled by A. H. Lukins and edited by D. A. Russell, M.I.Mech.E., is produced by Aircraft (Technical) Publications, Ltd., and published by the Harborough Publishing Co., Ltd., with the co-operation and approval of Westland Aircraft, Limited. Size 11 by 8½ ins., 104 pp., thread sewn and cloth bound in stiff boards, gilt blocked, and enclosed in an attractive three-colour dust-cover; price 12s. 6d. from any Bookseller or Model Shop, or 13s. 0d. post free from the publishers at Allen House, Newarke Street, Leicester.

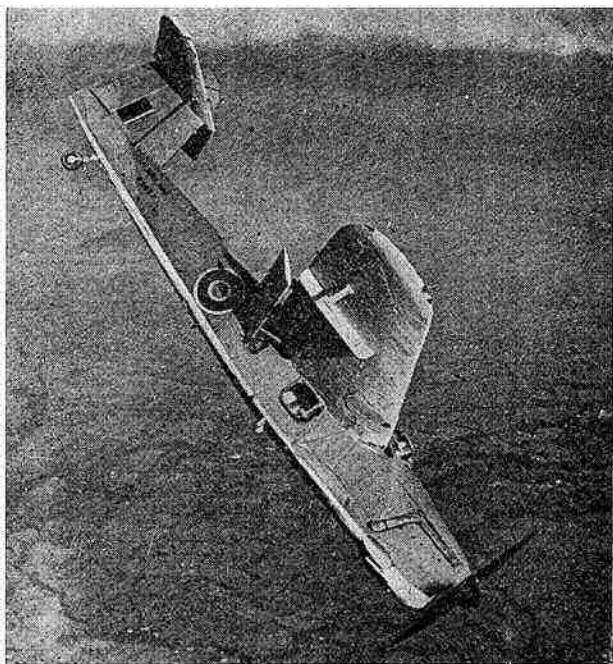

The Barracuda

British Official Photograph.

"Yellow Peril" of 1940.

It can now be revealed that the original De Havilland Mosquito, the Mk. I prototype W 4050, which first flew in November, 1940, was painted a brilliant yellow all over. Red, white and blue roundels, with no outline, were painted on the fuselage sides and on the wings. As regards colour scheme, the only feature in which it differed from a trainer of the 1935-38 period was the fin "flash" of red, white and blue stripes, which was painted in the standard size, 24 in. by 27 in. The serial number, W 4050, appeared on the rear fuselage in black.

Another 1940 Prototype.

The Hawker Tornado fighter, which first flew in October, 1939, and was dropped in 1940 in favour of the Typhoon now in service, was given the serial number P 5224. Most readers will be aware that the Tornado differed from the Typhoon only in the power plant, which was a Rolls-Royce Vulture instead of the Napier Sabre. As a result it had a longer nose than the Typhoon and four exhaust manifolds instead of two; the exhaust layout being similar to that of the Hector biplane. As flown in 1940, the Tornado P 5224 was camouflaged in dark green and dark earth on the upper surfaces and duck-egg blue underneath, which was the system then prevailing for fighters. The roundels were similar to those carried on the Hurricanes and Spitfires of the period: i.e., red, white, blue and yellow on the fuselage with *wide* white ring; red and blue above the wings; and red, white and blue beneath each wing tip, again with a *wide* white ring. The red, white and blue vertical stripes were painted in the standard size rectangle on the fin. It is interesting to note in passing that the two prototype Typhoons, the 12-gun version and the 4-cannon version, were numbered respectively P 5212 and P 5216.

The writer has yet to see a representative collection of prototype solid models and believes that such a collection would attract considerable interest. Those interested are referred to a previous article in this series

MONTHLY MEMORANDA

BY O · G · THETFORD

appearing in the November, 1943, issue of this journal, in which a complete list of prototype markings appeared.

Barracuda Markings.

The Fleet Air Arm's latest torpedo-bomber of British design, the Fairey Barracuda, has been in service since early in 1943, and was officially released in April, 1944, after the successful attack on the *Tirpitz*. Barracuda torpedo-bombers with the Royal Navy are camouflaged in dark slate grey and dark sea grey on the upper surfaces and sea grey medium or sky type "S" underneath. Translated into common terms (the former being the official descriptions and virtually meaningless unless one has seen the colours described) this may be described as bluish-grey and green above and greyish-white underneath. The usual roundels appear on the fuselage and above the wings, but no roundels are carried *beneath* the wings. The usual "flash" appears on the fin, beneath the high mounted tailplane. The words "Royal Navy" are painted in small black letters just above the serial number on the rear fuselage. Batches of Barracudas have been numbered DP 879, DP 880, DP 881, etc., and DN 633, DN 634, DN 635, etc. Barracuda DN 633 carried the squadron code lettering "AC-F" in white on the fuselage aft of the roundel, the "AC" being grouped aft and the letter "F" (the individual machine letter) next to the roundel on the starboard side and next to the tail on the port side. Other Barracudas in the same squadron carried the letters "AC-A," "AC-B," "AC-C," "AC-D," etc. It will be noted that two types of exhaust pipe are fitted on Barracudas. The original type curved down to the bottom of the fuselage in the manner of the old Hart Trainers and Ospreys. The latest type, such as is fitted on the machine mentioned above ("AC-F"), is of the multiple ejector type with six outlets and the original cut-out in the side of the cowling remains, though redundant.

Wimpy's Big Brother.

Announcement has been made of the Vickers-Armstrongs Warwick transport monoplane, and one Warwick in service has the civil registration letters G-AGFK, together with Land Temperate camouflage and red, white and blue fin "flash." The civil letters are painted in black on the wings and fuselage and are underlined by red, white and blue stripes on the fuselage and red and blue stripes above the wings.

Aerial "Brown Types."

The latest addition to the Army's fleet of A.O.P. (Air Observation Post) aeroplanes is the Mk. IV version of the British Taylorcraft Auster. The Auster IV is generally similar to its predecessors but has the Lycoming motor, a longer perspex cabin roof and a tailwheel. The Auster IV is camouflaged dark green and dark earth on upper and lower surfaces and red and blue roundels appear beneath the wings. The normal roundels and fin flash appear on the upper surfaces. Serial numbers allotted to batches of Auster IV aeroplanes include MT 175, MT 176, etc., and MT 407, MT 408, MT 409, etc.

"P H O T O N E W S"

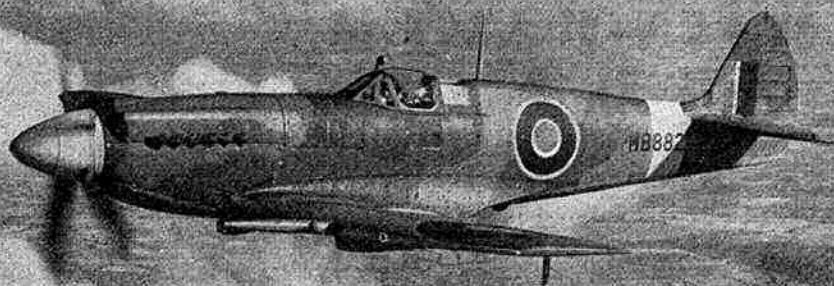

Photo: Chas. E. Brown.

The Spitfire XII (Griffon), shown above, has clipped wings, a pointed rudder and modified cowling lines.



Photo: Peter M. Bowers.

The latest version of the Warhawk, the P-40L (Merlin), has an extra 20 ins. of fuselage between the cockpit and the fin for improved control.



A.T.P. Photo

The enclosed cabin of the Taylorcraft Auster IV is quite warm in spite of wintry conditions below.



Photo: "Flight."

1,650 h.p. Hercules XVI motors are installed in the Halifax III (above). The wing span is increased to 104 ft. 2 ins., by fitting of rounded tips.

Photo: Fairchild Aircraft.

The Ranger-powered version of the Fairchild AT-14 Yankee-Doodle is shown above, right. It is being produced as the AT-21 and called the "Gunner."

Photo: Lockheed Aircraft.

The Lockheed F-5 (right), P.R.U. version of the Lightning carries cameras and is unarmed.

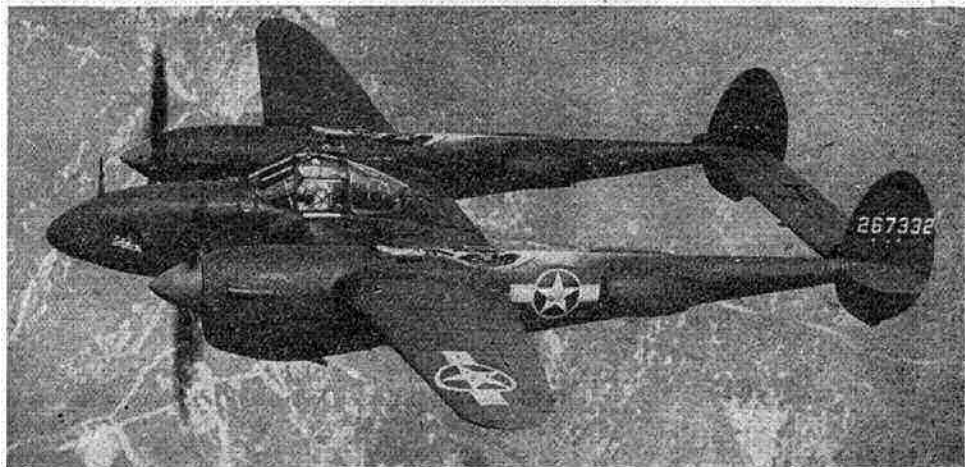

The MARTIN-BAKER M.B.2

BY H · J · COOPER

Next Month: The Fairey Barracuda

A FEW months before the outbreak of war information was released on a new eight-gun fighter monoplane produced by the Martin-Baker Aircraft Co., Ltd., of Higher Denham, Bucks.

This company had been formed in 1934 by Mr. James Martin (Chief Designer) and the late Capt. Valentine Baker, for so many years the popular instructor at Heston Airport. Their first product, the M.B.1, which appeared in 1935, was a two-seat enclosed low-wing monoplane employing the special method of steel-tube construction developed by Mr. Martin.

The fighter was built to an Air Ministry order, but a production order was not placed. The reason for this is not apparent, as the M.B.2 had a performance in the Hurricane-Spitfire category, and the constructional methods indicated that a high rate of output could be maintained. If necessary all parts could be sub-contracted and sent to a central plant for assembly. The M.B.2 was armed with eight .303 Brownings, and it is reported that it was extremely manœuvrable and generally pleasant to handle.

A Napier Dagger III 24-cylinder air-cooled "H" motor developing 805 h.p. was fitted to the M.B.2, and a maximum speed in the vicinity of 350 m.p.h. was attained. A two-bladed wooden airscrew was fitted, and oil-coolers were incorporated in the port under-carriage fairing.

The M.B.2 was entirely of steel-tube construction, with fabric covering over the wings, rear fuselage and movable control surfaces.

The pilot was situated in a compact streamlined cockpit, the cover hinged on the starboard side, and behind him was a retractable crash-pylon in case of a nose-over landing.

An unusual point concerning the appearance of the M.B.2 was that the length was actually greater than the

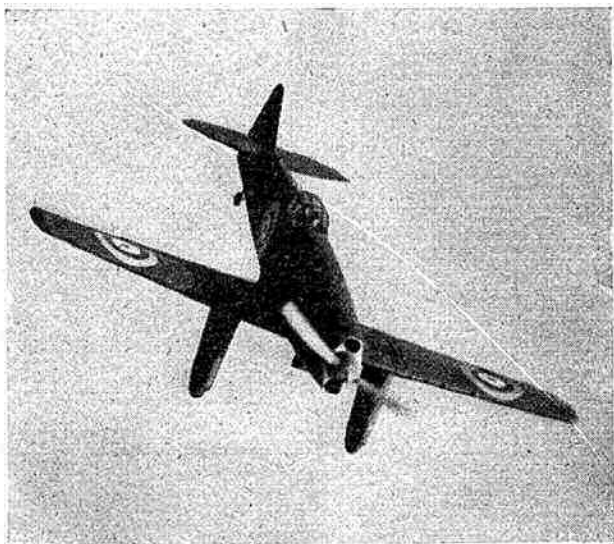

"Flight" Photo.

span, a feature of only one other British aircraft—the little Miles Hobby of 1937. Although the M.B.2 was not taken off the Secret List until May, 1939, it had in fact been in existence for many months prior to then, and the writer's diary records that this fighter gave him an identification headache so long ago as 10th November, 1938, when it was not publicly known.

The prototype M.B.2 was coloured dark green all over (the colour of the old Heyfords and other night bombers) and carried red, white and blue roundels with yellow surround on each side of the fuselage and above the wings. Below the wings the yellow outer ring was not carried. The serial number P 9594 was painted in black on each side of the fuselage in 12-in. characters, and on the rudder in slightly smaller figures.

Below the wings the number was in white in 36-in. figures with the tops towards the leading-edge on the starboard wing, and *vice versa*.

Main dimensions of the M.B.2 are: Span, 34 ft. 0 in.; centre-section span, 10 ft. 10 in.; root chord, 8 ft. 2 in.; tip chord, 4 ft. 0 in.; tailplane span, 11 ft. 0 in.; tailplane root chord, 3 ft. 8 in.; track, 9 ft. 8 in.; airscrew diameter, 10 ft. 6 in.; height (tail up), 12 ft. 1 in., length 34 ft. 6 ins.

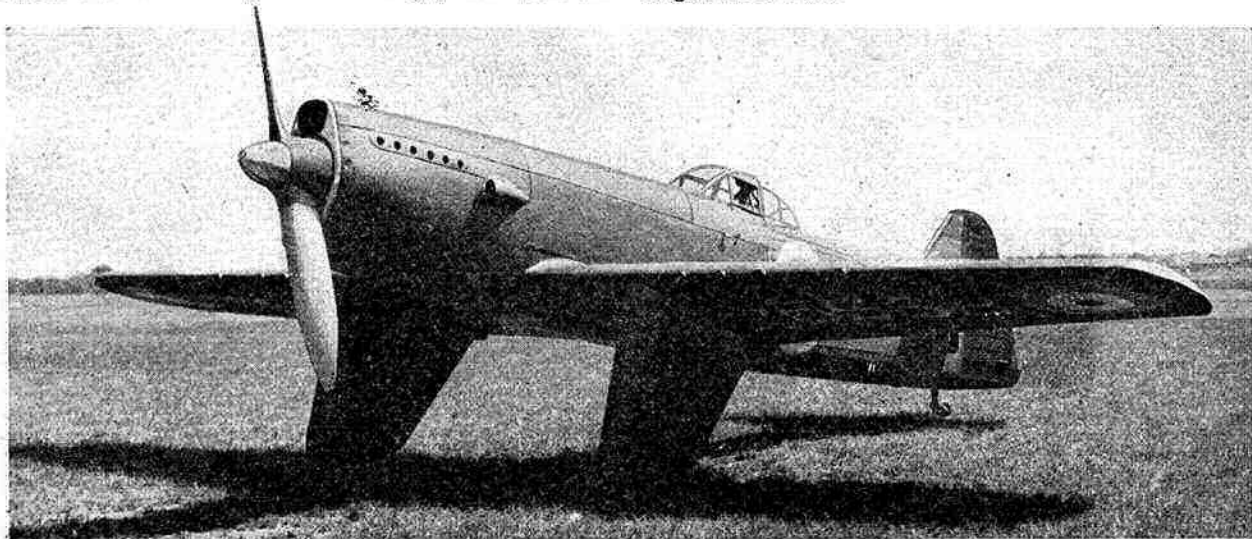

"Flight" Photo.

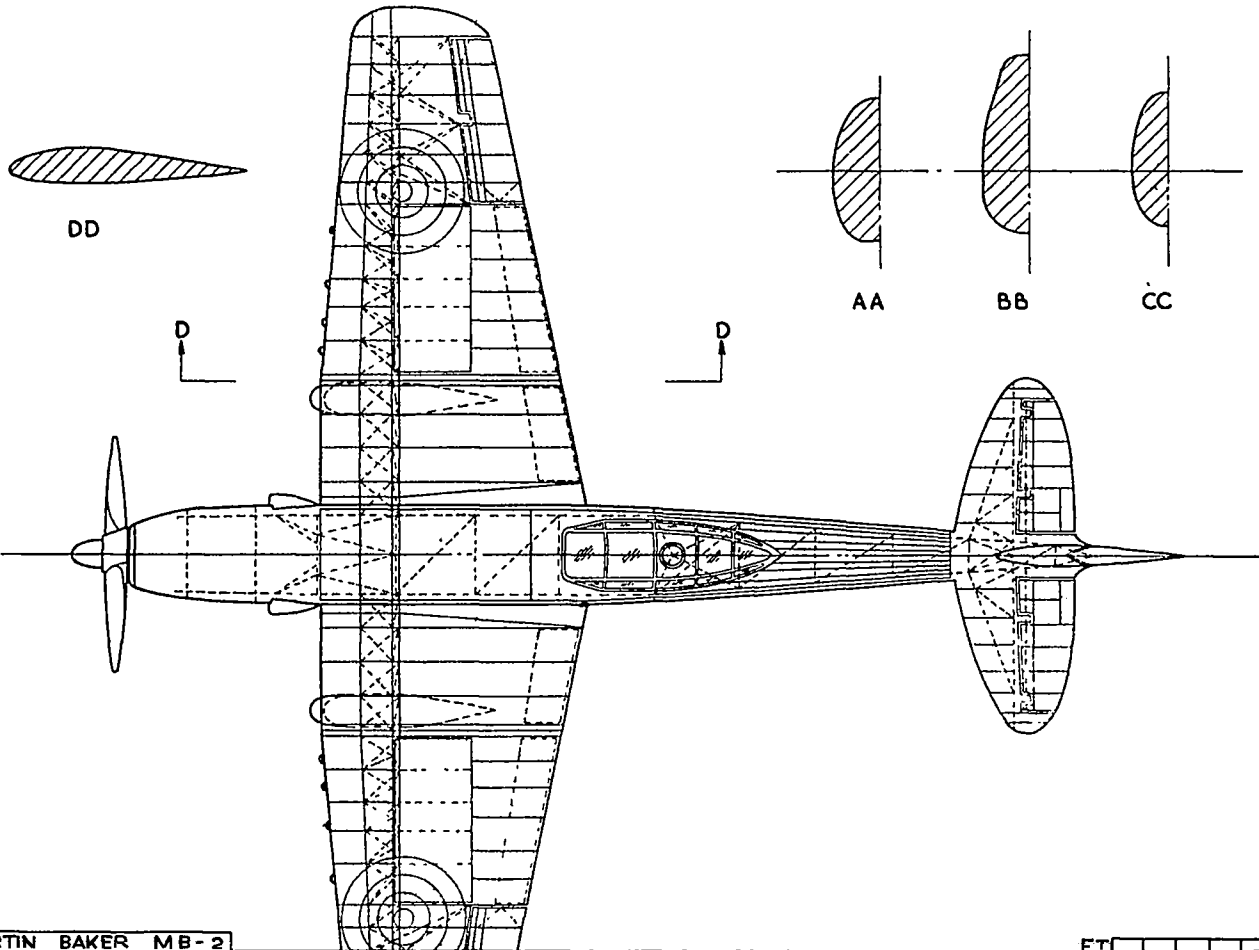
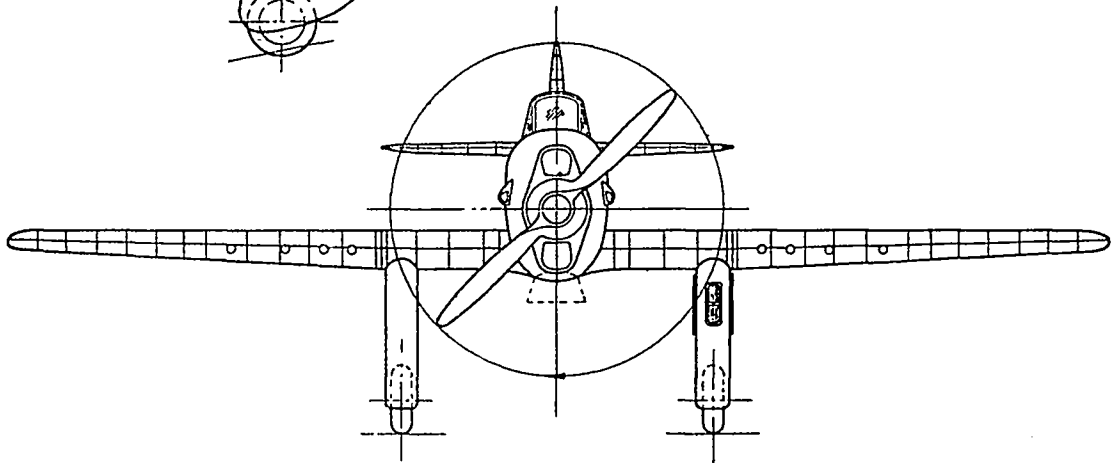
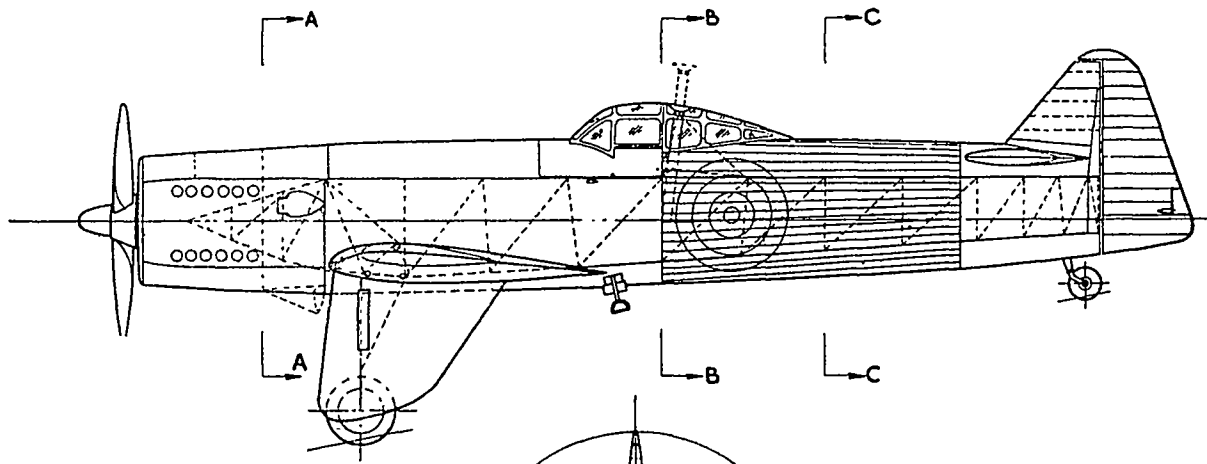

SKYLEADA

Model Aircraft Kits at their best

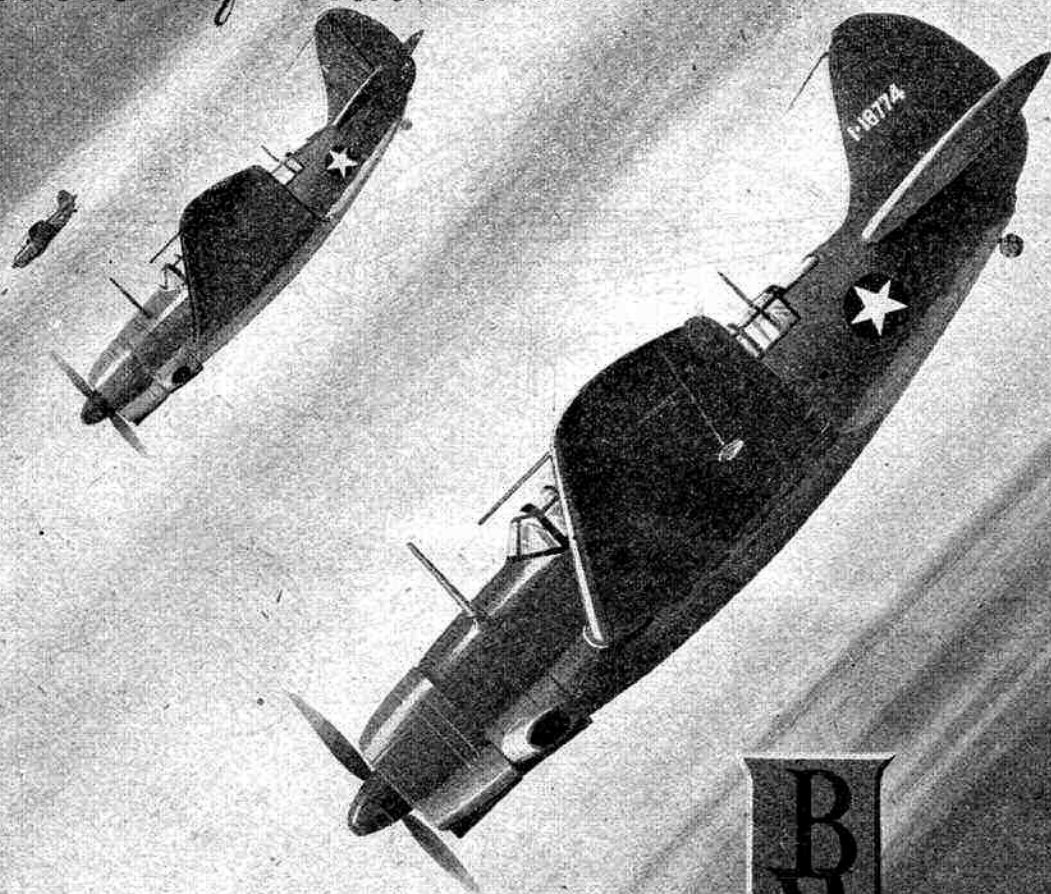

OWING TO LIMITATION OF SUPPLIES
DEMAND EXCEEDS SUPPLY
PLEASE BE PATIENT
TRY YOUR LOCAL DEALER



SKYLEADA

SOLID SCALE KITS

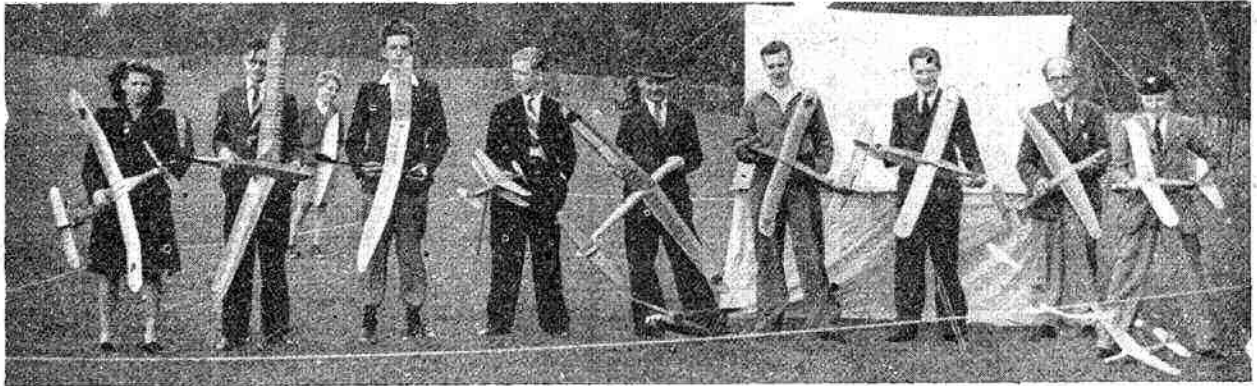

A cheery group of the Blackpool & Fylde M.A.S.

ONCE again the S.M.A.E. has put its foot in it, this time over the two Solid Silver Trophies offered by the Managing Editor of this journal, for the "Solids" Competition.

At the A.G.M. in 1942, a full 15 months ago, Mr. Russell offered the sum of 50 guineas to provide two 25-guinea trophies for solid models. This was acknowledged by the meeting with acclamation, but it took the Council nearly a year to even think up a set of rules for the competition! Announcements were made very late in 1943—in fact, so late that entries for the first competition, due to close on December 31st last, had to be carried forward, since the rules were only announced a few weeks beforehand!

Now I hear that certain people have been notified by the Competition Secretary of the S.M.A.E. that they have been awarded prizes, but not a word has come to the AEROMODELLER offices officially! It is usual, when substantial prizes are offered, for the donor to be extended the courtesy of an invitation to attend the judging—some people think the tactful thing to do is to ask the donor to assist in the judging. No official communication has been made to the AEROMODELLER as to whom the prizes have been awarded, and it has been left to Mr. Russell to find out, as best he can, to whom he should send the two silver cups which he was good enough to offer for these competitions.

When will the S.M.A.E. officials learn a little manners?

I have been meeting one or two chaps from overseas lately, and as usual the conversation veered round to aeromodelling. It is rather difficult to sort out all the pros and cons, but it appears that, while this country is regarded as top notch in the designing sphere, the general opinion is that we lag far behind America on the question of materials, particularly kits. All this of course discounted war-time conditions, for which obviously no one can be blamed. The main grouse was that many of the British suppliers only nibble at the market, and seem content to produce two or three lines of flying type models, whereas the average American catalogue is extensive in comparison.

While not altogether agreeing with the above, there is certainly food for thought, and I trust the trade is keeping in mind the potential boost in aeromodelling that will come after the war. Many would-be enthusiasts are handicapped these days through either lack of materials or time, and I foresee a terrific activity in the aeromodelling field when conditions allow.

Well, the contest season has started off with a big bang, the Gamage Cup event for once not qualifying

for its unenviable title of "Damage Cup." Apparently the weather was fine in most districts, and the total of 295 entries is a record for a national competition. Forty-two clubs in all competed, and the winners are to be congratulated on a fine show. Pharos are again to the fore with two places in the first six, though Bushy Park are ahead on position for clubs, apparently by placing their third man higher than Pharos.

Thermals must have been two a penny, and Buckeridge's total of 16:49.7 must have entailed a lot of chasing. I have no details of individual flights, but hope to give the best times next month. For the present, here is the listing for the first six, for which I am indebted to Mr. Towner, who has been most co-operative. A fine start to the season, and here's hoping the balance of the 1944 programme is as successful.

1944 GAMAGE CUP

23rd April

		Aggregate
1. Buckeridge, J.	Pharos	1009.7
2. March, J.	Bushy Park	827.5
3. Buxton, T.	Croydon	819.5
4. Buckeridge, Mrs.	Pharos	805.6
5. Taylor, A. H.	Bushy Park	783.9
6. Warring, R. H.	Blackheath	749.0

295 entries. 42 clubs.

The THAMES VALLEY M.A.C. held a meeting on the 2nd April for the purpose of setting up a set of club records. Times, however, were so bad that the project was abandoned—the best flight made by a rubber-driven model being only 44.5 seconds. A later meeting, however, saw a glider record (pulley launch) of 1:12 set up by J. M. Stevens, though this figure is not expected to last for long.

Membership in the MIDDLESBROUGH & D.M.A.C. is steadily rising, and now tops the 50 mark. Flying times have not been too good in competitions, though better times have been set up unofficially—they always are!! Best flight to date is one of 5:50 by W. F. Holmes' lightweight glider, who also has the best time to date for rubber-driven jobs, namely 2:15. Experiments have been made with pulley launching, and this has proved highly successful, especially with heavyweight jobs.

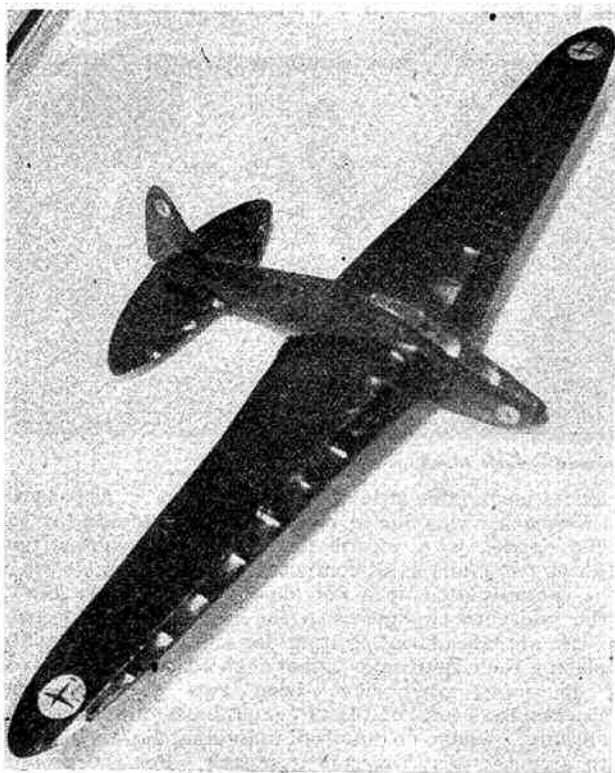

"Cherry Blossom" finish 1. An A.P.6 sailplane built from Aeromodeller Plans Service plans by G. Saxby.



Good effort from a 14 year old modeller. Nicely posed Strling by Clifford Fox of Mitcham.



S.M.A.E. SOLIDS CONTEST 1944.

Trophy No. 1.

Winner. G. R. Woollett, Bromley Solid M.A.C., The Green, Yalding, nr. Maidstone, Kent. "Typhoon," $\frac{1}{2}$ in. scale.

Second. E. V. Pullen, 22a, Goring Way, Greenford, Middlesex. Sopwith Salamander, $\frac{1}{2}$ in. scale approx.

Third. Sqdn. Leader S. Vickers, c/o G.P.O., Shepperton, Middlesex. "Typhoon," 1 in. scale.

Trophy No. 2.

Winner. George Temple, East Mersea, Colchester, Essex. Nuffield Heston Racer, $\frac{1}{2}$ in. scale.

Second. I. W. Moore, "Grey Pool," Station Road, Mickleover, nr. Derby. S.6B. Schneider Winner, $\frac{1}{2}$ in. scale.

Third. R. A. Chivral, 108, Catford Hill Catford, S.E.6. "Halifax," $\frac{1}{42}$ nd scale approx.

BRADFORD M.A.C. held their annual dinner and prize-giving recently, the Brown Muff Trophy going this year to W. Cripps, while a real selection—four trophies in all—were carried away by junior member R. Gallagher. Best flights of the past season were put up by F. M. Gallagher, who flew gliders for 2:45 o.o.s. hand launched, and 2:21 winch launched.

A number of new records have been set up in the PENN M.A.C. as follows:—

Duration, R.O.G.	1:25	S. Ward.
Indoor Flying Scale	21.75	S. Ward.
Indoor Free Flying	51.05	S. Ward.
Glider (Tow Launch)	40.0	G. Caddick.
Glider (Winch Launch)	55.0	G. Caddick.
Flying Scale "Puss Moth"	1:0	D. Newman.
R.T.P. Class A (H.L.)	2:0	S. V. Leadbetter.
R.T.P. Class A (R.O.G.)	1:56	S. V. Leadbetter.

The policy of the BIRMINGHAM M.A.C. in encouraging other clubs to take part in their events is proving a wise one, and a good spirit of camaraderie is being fostered. The first competition of the season (for gliders) attracted thirteen entries, MacMillan winning with only one flight, 4:37.5, the runners up being Bolton of the North Birmingham Club with a total of 3:10.2, and Monks with 2:15.8. An inter-club cup is being flown for this year between the Birmingham and Leicester Clubs, the dates being 11th June at Leicester, and the return at Birmingham on the 23rd September. I am pleased to see this type of inter-club activity, as it is the finest way to promote good will among clubs, and all must benefit in consequence.

An exhibition staged by the DALMELLINGTON YOUTH WELFARE M.A.C. was well supported, sixty-four machines being on show, the majority being duration models. An outstanding exhibit was a solid scale Supermarine S.6.B. An r.t.p. contest between the club and the Ayr Y.M.C.A. resulted in a win for the Ayr lads.

The season's flying opened at the LANCASTER & MORECAMBE M.A.C. with a contest for the best flight—winner being S. Ellis with 2:39, followed by G. Thomson,

2 : 20, and B. Redman, 1 : 37. All the models were "Atalantas," this type being very popular in the club.

The NORWICH M.A.C. got some well-earned press publicity when a spate of thermals put in an appearance on Easter Monday, and two models "went for a Burton" during the day. L. Claydon flew his "Mick Farthing Lightweight" away after 6 minutes o.o.s., while a junior member lost his model, unfortunately not timed. Another junior, eleven-year-old R. Jeeves, recorded a flight of 2 : 15 o.o.s.

LEEDS M.F.C. have been fortunate enough to obtain the use of a new flying field, and I am told it is a big improvement on the old one. The first time this field was used, junior member K. Lloyd lost his lightweight glider after approximately 4 minutes o.o.s. Best rubber-driven time so far is 2 : 04 by H. Tubbs' lightweight. It is intended to stage a Rally on the 23rd July, and full particulars can be obtained from the secretary, H. E. Vauvelle, 10, Barthorpe Crescent, Leeds, 7.

The BRENTWOOD SCHOOL M.A.C. recently held a highly successful exhibition in the School Hall, 116 models being on show, including nearly all the entries in the S.M.A.E. National Solids Contest for the Southern England section. Winning model was a replica of the Heston Napier Racer built by "George" Temple. This model is a work of art, and includes a working retracting undercart, and fully detailed cockpit interior. Scale is 1/24th. R.T.P. flying was demonstrated on the stage, and aroused a great deal of interest. A great number of people visited the show, and a good sum was raised for the local hospital in consequence. A good

ANNUAL WELSH RALLY
 Organised by the
EBBW VALE MODEL FLYING CLUB
 Contest for both duration and glider types,
 under S.M.A.E. Decentralised Rules.
 Full particulars from : A. W. R. Martin,
 22, Alfred Street, Ebbw Vale, Mon.

show for a bunch of lads whose average age is only 16 years.

The duration and glider records of the AYLESTONE M.F.C. were well and truly shattered this year, when just prior to the Gamage Cup contest W. Jones made a flight of 3 : 40.3, only to be beaten just after by F. Ivory, whose model set up a new figure of 5 : 42. His aggregate for three flights was 9 : 25.4. Jones later put up a new club glider record with a time of 2 : 45 on a 200-foot line. Some kind gentleman has presented the club with 3 lbs. of strip rubber, to enable the members to enter for the S.M.A.E. contests!

An interesting meeting was staged by the HARROGATE AIRCRAFT CLUB, when visitors from many surrounding clubs took part. Good weather at the start deteriorated later in the day, nevertheless some good flying was seen. Results were as follows :—

Open Duration	C. Furse (Leeds)	1 : 49.5
	H. Tubbs (Leeds)	1 : 33

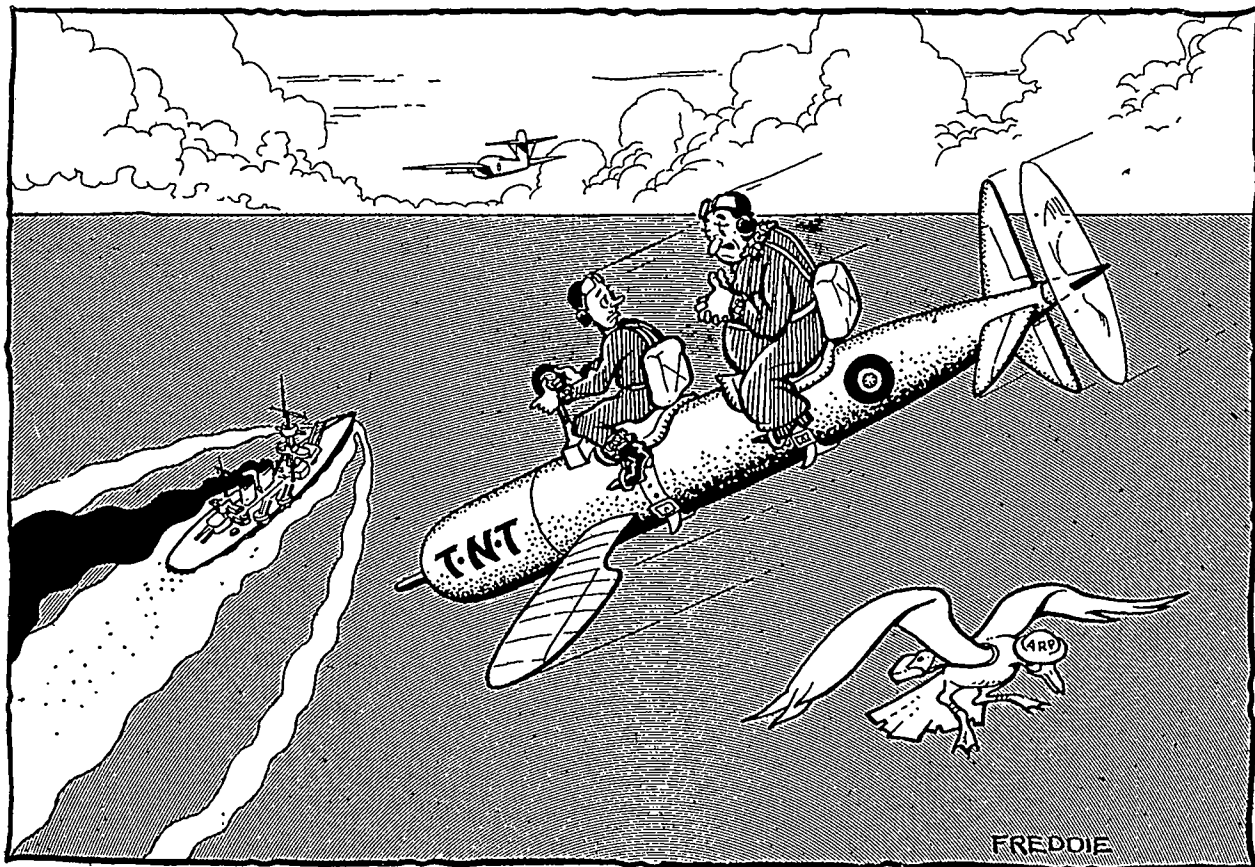

“OF COURSE, THERE'S NO FUTURE IN IT”!

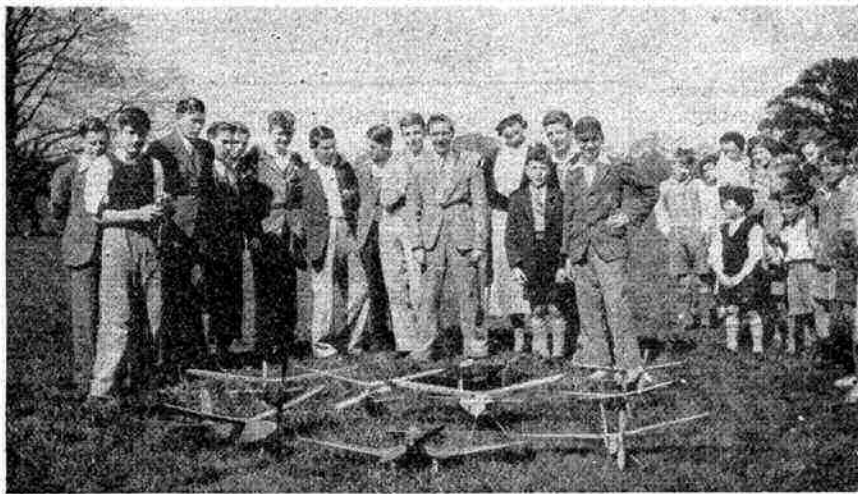

An early meeting of the Pharos M.A.C., complete with admiring small boys (these, like Gremlins, are never absent from flying fields).

Open Glider	C. Furse (Leeds)	2:13.2
	N. Acorn (York)	2:07
Under 40 in. span	C. Furse (Leeds)	2:37
	C. Clint (York)	2:26
Nearest 45 secs.	Summersgill (Harrogate)	45.1 secs.
Best Flight of the Day	B. Crooker (Leeds)	2:24 o.o.s.

The MERSEYSIDE M.A.S. opened the season with practically every member bringing out a new model—possibly the most interesting being I. S. Cameron's lightweight duration, "Wirral Wanderer." This model has only flown a few times, but has gained itself a reputation with flights of 2:51, 2:31.6 and 2:15. (Hear about the bloke who turned up on the field with a three-foot box made entirely of BALSAA!! Wonder what happened to him?)

Flying is going ahead now with the DONCASTER & D.M.A.C., the first meeting of the season seeing some good flying from M. Hetherington, 2:14; S. Bassett, 2:01.5; F. G. Gearing, 1:42; and D. Helliwell, 1:47.5 with a glider. The r.t.p. record is held by Hetherington with a time of 2:30. Flying is held on the Town Field, Doncaster, and the Flying Field, Sprotborough, whenever the weather is suitable, and interested folk in the area are welcomed.

The BLACKPOOL & RYLDE M.A.S. have launched

out with a quite well-produced club journal, containing much interesting material. Congratulations. Best r.t.p. flights for March were made by D. H. Whittaker (Class B), 1:55.5, and R. V. Bentley (Class A), 1:50.1. R.T.P. flying has been a feature of the weekly indoor meetings, and has done much to hold the club together during the "close" season.

Four members of the BRISTOL & WEST M.A.C. went up to the S.M.A.E. Annual General Meeting, and reported an interesting—and enlightening—time, marred somewhat by lack of accommodation. The last club winter gliding

contest was very poorly attended in spite of fine weather. M. Garnett won with an aggregate for three flights of 1:46.5. Since then, members have been concentrating on building and trimming models for the new season, one junior being unfortunate enough to lose his new 24 in. span lightweight in a March thermal.

The BUSHY PARK M.F.C. started the season well with M. A. Wright averaging 2:20 with a lightweight, and then losing a heavyweight model after 5:05. A. T. Taylor then proceeded to lose a F.A.I. glider after a flight of approximately 5 minutes from an 80 ft. towline. The next big gathering was on Chobham Common for the Gamage Cup event. The weather was fine, and very soon model No. 1 soared out of sight at a great distance. The model, flown by J. March, was timed for 13:01.5. Next went a lightweight by A. T. Taylor for 9:20.5, then A. H. Taylor's model disappeared after 12:18.9. M. A. Wright's model then went o.o.s. after 8:31 at a great height. From these extensive operations, four of their aircraft are missing!

News comes from six new clubs this month (see list at the end of these columns) and the following two chaps wish to get groups going in their areas. B. Pegg, of 96, Bullsmoor Lane, Enfield, Middlesex, would like others in that district to contact him, while J. L. King, of 8, Logan Mews, London, W.8, is interested in forming a club for Scottish model enthusiasts living in London and surrounding districts.

Well, so much for this month, and I trust the new season is going to produce tons of thermals (but no lost models!) and the best of weather for all competitions. We stu struggle along in spite of limitation of supplies and other difficulties, and we can console ourselves with the thought that the good old days will eventually come back. I can foresee a big boost in the petrol flying game after the war, with quite a lot of attention given to radio control, so we have plenty to look forward to. May, it come soon. Bungo for another month.

THE CLUBMAN.

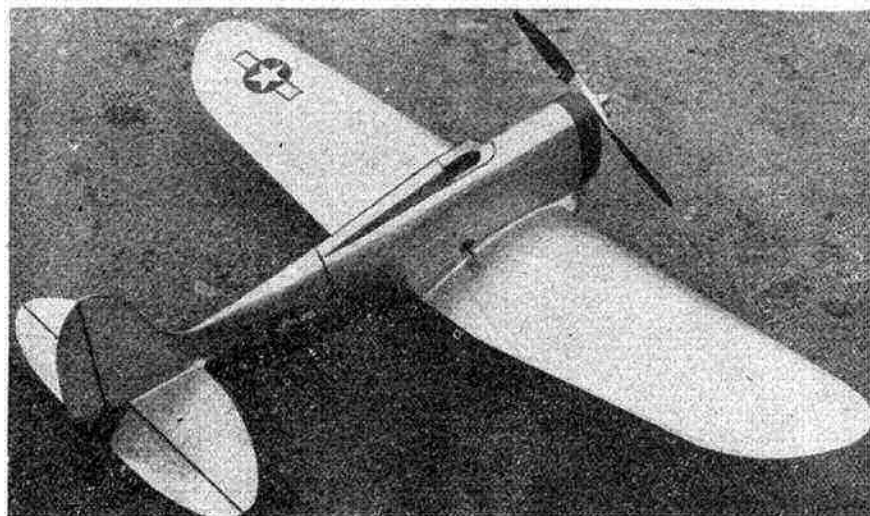

Photo by courtesy of Model Airplane News.

An exceptionally clean-looking control line petrol model of 52 in. span. It incorporates a retractable undercart, and was built by George Moon, an American modeller.

New Clubs

- HATFIELD M.A.C.
D. Hyde, 55, Stonecross Road, Hatfield, Herts.
NEWPORT & D.M.A.C.
G. Baker, 4, Halberry Lane, Newport, Isle of Wight.
NORTH ROMFORD M.A.C.
E. J. Wager, 7, Brockley Crescent, Romford, Essex.
WELLINGTON (SALOP) M.A.C.
J. Eatough, 6, Haygate Road, Wellington, Salop.
S10 (WIDNES) SQUADRON A.T.C. M.A.C.
R. W. Kidd, 8, Beaconsfield Crescent, Widnes, Lancs.
PORTSMOUTH MODEL-MAKING SOCIETY.
M. Henderson, 21, Maurice Road, Milton, Portsmouth.

A HORIZONTAL SINGLE-CYLINDER ENGINE.

Continued from page 360.

a petrol-oil mixture, of a quantity sufficient to fill a tank corresponding in size to the outer dimensions of a 10 cc. cylinder, is 1½ ozs. With such easy facilities for filling the tank there is really no reason why it should be allowed to become completely empty while flying is taking place. The weight variation, therefore, need not exceed about 1 oz. In any case, the variation in weight is taking place exceedingly near to the centre of gravity of the aeroplane. A 10 cc. engine would fly a model

of 8 to 10 ft. span, and I doubt whether such a small variation would be evident in the machine's behaviour. I am not sure that I have ever balanced my aeroplanes to these limits.

The last consideration is that of weight, and I do not believe that this should be any more than that of a normal engine. In my drawing I have made the tank to appear a somewhat thick and heavy member, but there is no reason why this should be so. In fact, were die castings used in its manufacture, it might be a mere shell with the outward semblance of a cylinder. I would, by the way, suggest that a dummy plug be fitted for the sake of appearances. My engineering friends may shudder at this blatant disguising of a tank as a cylinder, but I have no qualms about the matter. After all, is not almost all model engineering, especially scale modelling, the art of simulation?

Thus I present this design, in which, I trust, I have shown that some good, and even unique benefits may lie. In any case, it forms a sincere attempt to get out of the rut—that deadening, eternal groove into which all things tend to slide.

THE ASSOCIATION OF BRITISH AEROMODELLERS

FOUNDER MEMBERS' DONATIONS

	£	s.	d.
Sir Robert Bird, Bart.	10	10	0
S. Smith	5	5	0
D. A. Russell	5	0	0
L. H. Sparey	5	0	0
C. S. Rushbrooke	5	0	0
S. Lorch	5	0	0
L. Gabe	5	0	0
Anonymous	5	0	0
E. Keil	5	0	0
L. Stott	5	0	0
D. G. Brown	5	0	0
C. W. Lutman	5	0	0
P. Hunt	3	3	0
W. J. Blore	3	3	0
H. G. Hundley	3	0	0
Mr. and Mrs. Germany	2	10	0
G. Rickard	2	10	0
Mrs. V. C. Rickard	2	10	0
C. R. Moore	2	2	0
D. B. M. Wright	2	2	0
C. S. Wilkins	2	2	0
F. R. Barnard	2	2	0
L. G. Temple	2	2	0
W. J. Forster	2	2	0
A. H. Lee	2	2	0
C. A. Rippon	2	0	0
J. P. Forster	2	0	0
K. M. Tansley	2	0	0
E. Snape	2	0	0
V. Botta	2	0	0
E. J. Riding	1	1	0
H. F. Dare	1	1	0
A. E. W. Simes	1	0	0
A. Elgar	1	0	0
H. Watkins	1	0	0
C. J. Bradstreet	10	6	
H. E. White	10	0	
LAC. D. Copeland	10	0	

£113 17 6

DONATIONS FROM THE TRADE

	£	s.	d.
AIRCRAFT (TECHNICAL) PUBLICATIONS, LTD., London. On behalf of the Model Aeronautical Press, Ltd. (Proprietors of the AEROMODELLER), The Harborough Publishing Co., Ltd., & AEROMODELLER Plans Service, Ltd.	105	0	0
E. KEIL & CO., LTD., London	26	5	0
ANONYMOUS	26	5	0
AUTHENTIC MODEL Co., Warrington	21	0	0
KANGA MODELS, LTD., Birmingham	13	13	0
CHINGFORD MODEL AERODROME LTD., London	10	10	0
MODEL AIRCRAFT STORES (BOURNEMOUTH), LTD., Bournemouth	10	10	0
ASTRAL AERO MODEL Co., Leeds	10	10	0
MODEL AERO SUPPLIES, Halifax	10	10	0
PREMIER AEROMODEL SUPPLIES, LTD., London	10	10	0
AEROMODELS LTD., Liverpool	10	10	0
"DON" MODELS, Brixton	10	10	0
JARRET RAINSFORD & LAUGHTON, Birmingham	10	0	0
THE BITTERNE ELECTRICAL INSTALLATION Co., Southampton	5	5	0
HENRY START & SONS, Wolverhampton	5	0	0
A.T.O. MODEL CRAFTS, Belfast	5	0	0
SUPER SCALE KITS, Uppingham	5	0	0
H. G. WELCH, Preston	5	0	0
BRISTOL MODEL AERO SUPPLIES, Bristol	3	3	0
NORTHERN MODEL AIRCRAFT Co., Manchester	3	3	0
CATON, LTD., London	3	3	0
SKYCRAFT MODELS, Ipswich	3	3	0
E. LOVEARD, Hornchurch	3	3	0
A. E. RYALL, West Drayton	3	3	0
YORKSHIRE MODEL SUPPLY Co., LTD., Halifax	3	3	0
F. C. KING & Co., Cardiff	2	2	0
JORDAN'S (NOTTINGHAM), LTD.	2	2	0

£327 3 0

ANOTHER ADDITION TO OUR 1/4 SCALE RANGE—THE "MUSTANG"

NOTE THE SPECIAL FEATURES OF THIS KIT. The Plan primarily refers to "MUSTANG" 1, but the main features of all versions are given, and materials supplied for building all types.

A comprehensive general description of the machine, particulars of performance, armament, etc., also recognition features are printed on the Plan.

"Aeromodels" Kits are complete. FUSELAGE SHAPES ARE CUT IN BOTH PLAN AND PROFILE VIEWS. Positions for Gun Turrets, Centre Sections and Tail Planes are READY CUT OUT OF FUSELAGE. Separate SHAPED CENTRE SECTIONS, TAIL PLANES AND RUDDERS are provided.

● THE FOLLOWING TYPES NOW AVAILABLE :

North American "MUSTANG," Hawker "TYPHOON," Supermarine "SPITFIRE," Hawker "HURRICANE," Westland "LYSANDER," Boulton Paul "DEFIANT"

(Other types in preparation.)

PRICE 6/3 EACH.

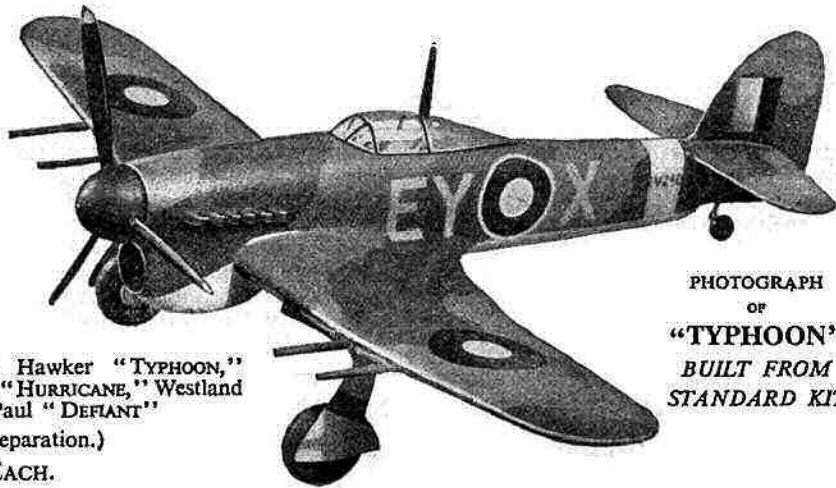

PHOTOGRAPH
OF
"TYPHOON"
BUILT FROM
STANDARD KIT

SEND 1d. IN STAMPS FOR OUR ILLUSTRATED LEAFLET OF SOLID SCALE KITS.

AEROMODELS LTD. Dalmeny Street, LIVERPOOL 17

JOY-PLANE PRODUCTS

A Government Order now in force restricts the packing of all painting products to a minimum $\frac{1}{2}$ -pint tin, when stocks of smaller containers made before July 9th, 1942, are exhausted. See details below.

In the Royal Air Force, Anti-Aircraft Batteries, Royal Observer Corps, Air Cadet Training Corps and schools, the men of to-day are becoming more and more Air-minded and models are being constructed for recognition purposes, etc., with Joy-Plane products

BALSA CEMENT, 5d. Tubes.

LUMINOUS PAINT, Bottles, 7½d.

LUMINOUS PAINT, Outfits complete with U/coat. 1/8, 2/10

WING DOPE, $\frac{1}{2}$ -pint, 4/-

FIELD CEMENT, Tubes, 7½d.

BANANA OIL, Thick or Thin, $\frac{1}{2}$ -pint, 4/-

TISSUE PASTE, Jars 1/3

COLOURED MODEL DOPES (Opaque colours) $\frac{1}{2}$ -pint tins 4/-

MATT. Brown, Green, White, Black, Grey, Duck Egg Blue, Heinkel Blue.

GLOSSY. Camouflage Brown and Green, Yellow, Red, Light Blue, Dark Blue, Light Green, Grey, Black, White, Brown.

PLASTIC BALSA WOOD, $\frac{1}{2}$ -lb., 1/3



TRULY AN ESSENTIAL PART OF WAR TRAINING

THE TURNBRIDGE MANUFACTURING Co., Ltd., 52a/62a Longley Road, S.W.17

Kindly mention **THE AERO MODELLER** when replying to advertisers.

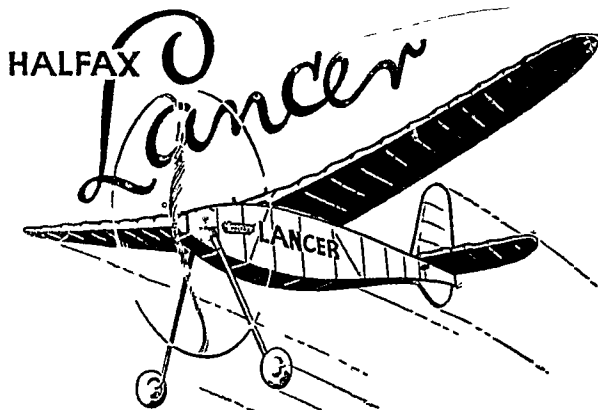

37-in. SPAN. DURATION. Price 15/-

YOU HAVE THE CHOICE OF TWO PROVED DURATION MODELS IN THE "LANCER" AND "COMMANDO." SEND FOR ONE TO-DAY

"SILVERWING" 1/72-in. Scale SOLIDS

MESS. 109F	1/6	WHIRLWIND	2/6
SPITFIRE V	1/9	M.E. 110	2/9
HURRICANE II	1/9	BEAUFIGHTER.. .. .	3/3
BUFFALO.	1/9	JU. 88	3/9
KITTYHAWK	1/9	BOSTON	3/9
LYSANDER	2/-	HAVOC	3/9



21-in. SPAN. CABIN DURATION. Price 5/-

"HALFAX" 1/48-in. SOLIDS

TYPHOON, MUSTANG, SPITFIRE, HURRICANE, DEFIANT, AIRACOBRA, MESS. 109, TOMAHAWK
Kits include Coloured Dope, Transfer Insignias, Sandpaper, Plan and Instructions, etc. Price 4/6

"SWALLOWCRAFT" SHIP KITS OF CORVETTE and DESTROYER ... 2/11 each

Include Cash for Postage and S.A.E. with all Enquiries

BRADFORD AERO MODEL CO., Ltd., 75a, Godwin St., BRADFORD, Yorks.

Telephone 12215

NORTHERN FACTORS of the famous series of

'SKYLEADA' • 'SKYROVA' & 'PILOT' and MANUFACTURERS of 'M.S.S.'

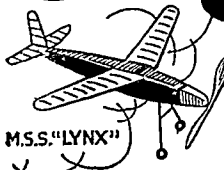

M.S.S. "LYNX"



PILOT "MOSQUITO"

THE FOUR ACES for FLYING MODEL "ACES" M.S.S. COMPLETE KITS

"LYNX"	40½ in. Span
"LYNX CUB"	30 in. Span
"PANDA"	38 in. Span
"GREYHOUND"	22 in. Span

ALL BEST MAKES OF KITS STOCKED

Now Ready—"NORITH" SERIES TRANSFERS

SHEET A.	BRITISH FIGHTER	6d.
B.	MEDIUM BOMBER	6d.
C.	HEAVY BOMBER	6d.
D.	GERMAN FIGHTER	4d.
E.	MEDIUM BOMBER	5d.
EE.	HEAVY BOMBER	6d.
F.	Sets of ¼" LETTERS	4d.
FF.	SQUADRON MARKINGS (10)	6d.

Post 2½d. Others in course of preparation

"SKYLEADA"

SOLID SCALE KITS, 1/9 each, complete

JUST PUBLISHED

"SOLID MODEL AIRCRAFT"

(CONSTRUCTION AND FINISH.)

Beginner or Expert will find all he wants in this new book.

WELL ILLUSTRATED.

ONLY 2/6 POSTAGE 3d.

Try your Local Dealer first—if he cannot supply, show him this advert—then send direct to us, but include 4d. extra for postage.

New "Balsa" substitute woods and all materials in plenty. The best of everything for flying and solid enthusiasts.

ALWAYS OBTAINABLE AT M.S.S.



Model Supply Stores

17 BRAZENNOSE STREET · MANCHESTER 2

Telephone No. BLA 6159

Kindly mention THE AERO MODELLER when replying to advertisers.

TRANSFER SETS

1/72" Scale

FIGHTER 5d. set.
 LIGHT BOMBER.. 6d. "
 HEAVY BOMBER 8d. "

NEW U.S.A. SETS

FIGHTER 6d. set.
 LIGHT BOMBER.. 9d. "
 POSTAGE ON ABOVE 2½d.

Fully detailed 1/72

**SCALE
MOTORS**

With Cowl.

½" diameter .. 6d. each.
 ¾" 6d. "
 1" 8d. "

ALL POSTAGE EXTRA.

GERMAN TRANSFER SETS

FIGHTER SETS, small, 3d. set. SMALL BOMBER, 5d. set.
 " " large, 4d. " LARGE BOMBER, 6d. "

CELLULOID MOTORS to fit ¾" Cowl .. 2d. each.
 DIRECTION FINDERS, 1/72" Scale .. 1½d. "

POSTAGE EXTRA.

NO KITS. (Send S.A.E. (1d. stamp) for New Lists)

THE MODEL SHOP

2, COLLEGE ROAD, BARRAS BRIDGE,
 NEWCASTLE-ON-TYNE

**CELLULOID COCKPIT COVERS FOR
1/72" SOLID SCALE MODELS**

SPITFIRE	2d. each.
HURRICANE	2d. "
MESSERSCHMITT 109	2d. "
HEINKEL	2d. "
TOMAHAWK (cover and radiator) (2 pieces)	4d. "
GLADIATOR	2d. "
BELL AIRACOBRA	3d. "
LYSANDER	3d. "
SKUA DIVE BOMBER	3d. "
TYPHOON	3d. "
D.H. 86B	3d. "
WHIRLWIND	3d. "
STUKA, cover, spats and radiators	9d. set or 3d. "
F.V. 190	3d. "
BRISTOL BLENHEIM	(4 pieces) 8d. set.
WELLINGTON	(4 ") 10d. "
BOLTON and PAUL DEFIANT	(2 ") 4d. "
WHITLEY BOMBER	(4 ") 8d. "
DORNIER BOMBER 17	(3 ") 8d. "
HAMPDEN	(4 ") 9d. "
HALIFAX	(7 ") 1/3 "
STIRLING	(6 ") 1/3 "
CATALINA I FLYING BOAT	(4 ") 1/3 "
JU. 88	(7 ") 1/6 "
LIBERATOR	(3 ") 1/- "
SUNDERLAND F. B.	1/6 "
MOSQUITO	1/- "
LIGHTNING, cover only	4d. or 8d. "
FORTRESS II	2/- "
LANCASTER	2/- "

ALL POSTAGE EXTRA.

Skycraft Ltd.

OF LEEDS

HUNDREDS OF KITS TO CHOOSE FROM AND
 EVERY ACCESSORY FOR THE AERO MODELLER.

"SILVERWING" SOLIDS. 1/72" Scale

ME. 109, 1/6 SPITFIRE, 1/9 HURRICANE, 1/9 BUFFALO, 1/9
 KITTYHAWK, 1/9 LYSANDER, 2/- WHIRLWIND 2/6 ME. 110, 2/9
 BEAUFIGHTER, 3/3 BOSTON, 3/9 HAVOC, 3/9 JU. 88, 3/9

"HALFAX" SOLIDS. ¼" to 1 Scale

SPITFIRE HURRICANE II AIRACOBRA TOMAHAWK
 DEFIANT MUSTANG TYPHOON ME. 109

4/6 Complete Postage 5d.

"HALFAX." LANCER 15/- COMMANDO 5/-

ALL "BALSA" DURATION MODELS

Enquiries must have S.A. Envelope

SKY CRAFT LTD.,
 39a, BOAR LANE, LEEDS 1

TELEPHONE:
 LEEDS
 23708

FULL RANGE OF WATER-SLIDE TRANSFER
 INSIGNIAS, CEMENT, DOPES, PROPS, STRIP,
 TISSUE, BOOKS AND PLANS, ETC. - - - -

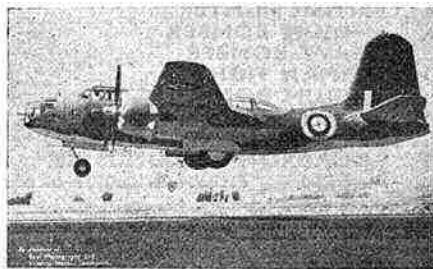

DOUGLAS "BOSTON"

Kindly mention **THE AEROMODELLER** when replying to advertisers.

Don't forget the Taylorcraft Competition



Prizes are offered for the longest hand-launched duration flight of a model Taylorcraft.

Plans and building instructions, price 2/- post free, are obtainable from Aeromodeller Plans Service Limited, Allen House, Newarke Street, LEICESTER.

TAYLORCRAFT AEROPLANES (England) Ltd. LEICESTER

SKYBIRDS

ONCE BUILT NEVER FORGOTTEN

SKYBIRDS—The FIRST and still the best 1/72nd TRUE TO SCALE Solid Model AIRCRAFT CONSTRUCTION

These are complete sets of parts for assembling various types of aircraft. Owing to restrictions due to the war, the range is at present limited to the most popular types, which include: SPITFIRE 4/-, HURRICANE 4/-, TOMAHAWK 4/-, LIGHTNING 7/6, MESSERSCHMITT 109F 4/-, and MIG-3 (Russian) 4/-

This fascinating hobby has captured the imagination of all persons who are interested in aviation and aeronautical modelling—if you

make a "SKYBIRD" Model it will mean more to you than a mere shop-made replica, for it will represent a personal triumph.



Join the 'SKYBIRDS' LEAGUE of model aircraft constructors.

Over 18,000 Modellers have registered.

For particulars write (enclosing postage 2½d.)

SKYBIRDS—THE MOST POPULAR HOBBY TO-DAY

SKYBIRDS (Desk A.M.)
9 Southampton Place, Holborn,
London, W.C.1

BRISTOL

"BEAU-GLIDER" KITS

MAKE SUPER SAILPLANES

No. 1. 31-in. span, 7/6 No. 2. 40-in. span, 9/8 No. 3. 50-in. span, 12/11
Carriage and packing 1/- extra in each case

If you belong to any of the following: R.A.F., Air Training Corps, Royal Observer Corps, National Association of Spotters' Clubs, Anti-Aircraft Units, Official Schools of Training in Aircraft Recognition, please state when ordering. This will ensure an all-balsa kit.

SPECIAL ANNOUNCEMENT

WE ARE OFFICIAL STOCKISTS OF
"MODEL CRAFT"

PLANS, AND CONSTRUCTIONAL AND INSTRUCTIONAL PLAN BOOKS

FULL RANGE OF OVER 100 PLANS IN STOCK.

1/72 SCALE AIRCRAFT, 00 GAUGE RAILWAYS, WATERLINE WARSHIPS, GALLEONS, SAILING YACHTS, OLD TIME SHIPS, ENGINES, ETC., ETC.

PLEASE SEND 3d. IN STAMPS AND AN ADDRESSED ENVELOPE FOR COMPLETE LIST TO:

'THE MODEL AIRPORT'
51, Colston Street, Bristol, 1

Kindly mention THE AEROMODELLER when replying to advertisers.

LIMITED QUANTITIES AVAILABLE

FLYING MODELS

ASTRAL, "STIRLING," 21/- Post 9d.
"BEAUFIGHTER," "HAMPDEN," "BLENHEIM BOMBER," 12/6 each. Post 7d.
"DEFIANT," "SPITFIRE," "AIRACOBRA," "HURRICANE," 8/6 each. Post 7d.

"KEILKRAFT"

ALL-BALSA FLYING MODELS

"HURRICANE," "SPITFIRE," "LYSANDER," 5/6 Post 7d.
"AJAX," 5/6 Post 10d. (includes packing charge)
"ACHILLES," 3/8 Post 7d.
"VICTORY-GLIDER," 4/6 Post 7d.

If you can send an official order it greatly helps future supplies. My 1944 List now ready—THREE PENNY STAMPS PLEASE.

GEORGE D. CAMPBELL,
Model Dept. AM.
46, HIGH STREET, DUMFRIES, Scotland

"DEWFLY"

MODEL AIRCRAFT BLUEPRINTS

THE "DE-H-HORNET MOTH." A nicely designed scale biplane, easily constructed with detachable wings, stabiliser and fin. Average duration 40-50 sec. Scale 1 in. to 1 ft. Price 2/9 Post 3d.

"THE DEWFLY." A 32 in. span cabin type high wing monoplane of smart appearance. Winner of many contests. Average duration 95-100 sec. Best official time to date 11 min. 4 sec. Price 2/- Post 3d.

"THE FALCON" A 48 in. span cabin type high wing Wakefield model of pleasing appearance. This model has proved very successful in competition, and has made many flights of over 10 min. Price 3/6 Post 3d.

THE "SWIFT." A towline glider of 46½ in span incorporating excellent appearance with super performance, equally suitable for Balsa or substitute construction. Price 2/6 Post 3d.

Large range of kits by leading manufacturers: Astral, Kellcraft, Aeromodels, C.M.A. Halifax, Skyleada, Skyrova, Worcraft, Grepwyn, Airyda etc.,

Also full range of 1/72 accessories, Cockpit covers, Waterslide transfers, Balsa cutters, etc. Stockists of Joy Plane products.

"DEWFLY" (MODEL) AIRCRAFT

C. P. DYNE LTD.,

158 Falcon Road, Clapham Junction, S.W.11.
and at 213 London Road, Mitcham, Surrey.



THE "FLUXITER QUINS" AT WORK
"That's just what our plot needs, that's plain!"
"A thundering good drop o' rain."
"What we need" shouted O!
"Is some FLUXITE, old boy"
"It's a burst in the bath-room again!"

See that FLUXITE is always by you—in the house—garage—workshop—wherever speedy soldering is needed. Used for over 30 years in Government works and by leading Engineers and Manufacturers. OF ALL IRONMONGERS, IN TINS, 8d., 1/4 & 2/8

Ask to see the FLUXITE SMALL SPACE SOLDERING SET—compact but substantial, complete with Instructions—1/6

TO CYCLISTS! Your wheels will not keep round and true unless the spokes are tied with fine wire at the crossings AND SOLDERED. This makes a much stronger wheel. It's simple with—FLUXITE—but IMPORTANT.



THE "FLUXITE GUN" puts FLUXITE where you want it by a simple pressure
Price 1/6 or filled 2/6

ALL MECHANICS WILL HAVE

FLUXITE

IT SIMPLIFIES ALL SOLDERING

Write for Book on the Art of "SOFT" SOLDERING and for leaflets on CASE HARDENING STEEL and TEMPERING TOOLS with FLUXITE. Price 1d. each.
FLUXITE LTD. (Dept. M.A.), Bermondsey St., S.E.1.

GEARS

16g. ¼ in. ½ in. ¾ in. 1 in. 1 1/8 in.

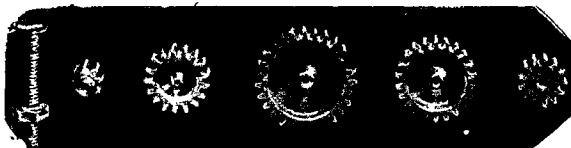

6d. 7d. 9d. 11d. 10d. 8d.

Postage extra. No C.O.D.

Bushes 7/8 in. long. All gears drilled 16 s.w.g.

CUP WASHERS, 16g. and 18g. 4d. per doz.
16g. Hook type Prop. Shafts 2d. each.
1" Gears to mesh with above range... .. 1/- each.

Since introducing the above range of GEARS the numerous letters of appreciation we have received show how well they are filling the needs of SCALE and EXPERIMENTAL model builders. These brass gears are of robust design, being 1/8" thick to avoid any possibility of stripping, but undue weight has been avoided by recessing the larger sizes. All gears mesh, so that any combination of step-up and reduction gearing can be built up, while the special tooth-form employed ensures smooth and easy running.

DELIVERY FROM STOCK

WE REGRET THAT DELIVERIES OF OUR 1" SCALE KITS ARE FOR THE PRESENT SUSPENDED, BUT HOPE TO BE ABLE TO ACCEPT FURTHER ORDERS IN JULY

SUPER SCALE KITS

UPPINGHAM, RUTLAND

SEA CRAFT SHIP KITS

Beautiful decorative models 12 to 15 inches in length. VIKING SHIP. Clinker built model of Norse ship built 1,000 years ago. Price 10/6

CUTTY SARK. Complete with Plan, Boats, Anchors, etc. Price 10/6

H.M.S. BOUNTY. Includes Plan, Guns, Dead Eyes, Boat, Steering Wheel, etc. Price 12/6

H.M.S. BRITANNIA. A Battleship of the line Period 1700, includes Anchors, 36 Guns, Dead Eyes, etc. Price 15/-
POSTAGE 7d.

All the above kits include a beautiful instruction booklet with 3-colour plates of the models.

Please make P.O. payable to SEACRAFT.

BIRMINGHAM MODEL SUPPLIES,
96, Dale End - - - BIRMINGHAM



COLINS MODEL SUPPLIES

FOR KITS, DOPES, JAP TISSUE, INSIGNIA, 1/8" and 1/4" PLY, ALUMINIUM AND CELLULOID TUBE, OBECHI STRIP, GLUES, CEMENTS AND PIANO WIRE.

MODERN NAVAL CRAFT PLANS

POSTAGE ON ORDERS AND ENQUIRIES TO:

48-52, West Street . . . Berwick-on-Tweed



No longer need 1/72nd Scale Solid Models be spoilt by bad painting. The E.V.B. modern method of Complete Waterslide Transfers are produced in authentic colours and markings.

MOSQUITO 2/6 FOCKE-WULF 190 2/-
MUSTANG 1 2/- TYPHOON 2/- MUSTANG Ia 2/-
TRADE ENQUIRIES INVITED.

E. V. BARNES, 19, Staines Ave., Nth. Cheam, Surrey

A. N. CUTLER

For Dopes, Tissues, Cements, Propellers, etc. In fact, all accessories for the Aero Modeller for solid and flying kits. Stockist of Drome, Studiette, Keil Kraft, Astral, Cloucraft, Skyleada, Truscale, Halifax, C.M.A., etc.

BRIDGE STREET WORCESTER
Phone: WORCESTER 4137.

"The Art of Scale Model Aircraft Building." By V.J.G. Woodson Edited by Walter Buchler. Price 4/11 net. 8/6 cloth.
"In this book the author has produced the most complete and accurate account of solid model making yet published. It is to be heartily recommended to the expert and to the beginner, and to those only interested in aircraft recognition instruction."—The Aeroplane.
"One of the best books on modelling."—Air Training Corps Gazette.
Also Kits, Paintings and Plans of Aircraft, Ships, Galleons, Micro Models, etc. Our Giftware Dept. is interested in all manner of useful articles and curios suitable as gifts.

USEFUL PUBLICATIONS
37, ALDWYCH, LONDON, W.C.2 (TEL.: TEM. 2946)

AERO MODELLERS get your

KITS AND ACCESSORIES
from
HARPER'S CYCLE CO., LTD.

34 Belgrave Gate & 67 Braunstone Gate, LEICESTER
Also at Oakham, Melton Mowbray and Market Harborough

STOCKPORT'S AEROMODEL SHOP

Phone: STO 4744

Kits and Accessories constantly in stock.

All the Harborough and Aeromodeller publications available.

54, Wellington Road South STOCKPORT

JONES BROS.

LARGE STOCK OF KITS, DOPES AND ACCESSORIES.
SPARE PARTS FOR SOLIDS
Send 3d. for list.

56, Turnham Green Terrace Phone: CHI 0858
CHISWICK, W.4

WILMSLOW MODEL AIRCRAFT CO.

PERSONAL ATTENTION MEANS A LOT TO THE AEROMODELLER! We make a point of advising as well as selling to our customers. We have a big range of Kits and Accessories, including: Keil Kraft, Skyleada, Studiette, Elite, Club, Astral, Airyda, Britannia, Lincraft, Grenwin, Halifax, Tower and many others.

GIVE US A CALL OR DROP A LINE TO:
WATER LANE :: WILMSLOW, CHESHIRE

GRENWYN (Regd.)

1/72 SOLID SCALE MODEL KITS

Will all clients please note change of address:—

LANCASHIRE MODEL AIRCRAFT SUPPLIES

"Grenwyn" Works, 47 Queen St., Farnworth, Lancs.
to where all future communications should be sent.

MODEL MAKERS!

Birch Veneer Offcuts 1/40" thick. Packets of useful pieces, 3x3" to 4x8"
About 5 sq. ft. 1/11 post paid. Double size 3/3 post paid.
12" Strips, 1" to 2" wide, about 7 sq. ft. 2/6 " "
18" " " " " 12 " 3/9 " "
24" " " " " 16 " 5/- " "

List of other Stripwood, 2d.

A. STEPHENSON (WEST HARTLEPOOL) LTD.
VILLIERS STREET, WEST HARTLEPOOL

"TIP-TOP" MODEL AIRCRAFT STORES

10, Kingston Road, Portsmouth

All Model Accessories in Stock.

- Waterslide Transfers of all Nations.
- Special Large Range of Cockpit-Covers.
- Limited Supply. Send S.A.E. for List.

NOTTINGHAM'S MODEL SPECIALISTS

POSTAL SERVICE SUSPENDED FOR THE DURATION

RADET ELECTRIC, 21, ARKWRIGHT STREET
NEAR MIDLAND STATION

YORKSHIRE AEROMODELLISTS

There are things to delight the hearts of all Aeromodellers at Yorkshire's "pukka" model shops.

SKYCRAFT, LTD., 39a, Boar Lane, LEEDS
BRADFORD A.M. CO., LTD. Godwin Street, BRADFORD
NICHOLL & BROWN, Commercial St., HALIFAX

LIVERPOOL MODEL AIRCRAFT SHOP

MODEL AIRCRAFT SPECIALISTS. EXPERT ADVICE GIVEN
Glider Kits: Veron, Elite, Keil Kraft, Flying Scale: Aeromodels, Astral.
Sold Scale: 1/72nd: Silverwings, Truscale, Skyleada, Airyda, Elite.

1/2": Aeromodels, Halifax.
Accessories for flying and solid models. Large range of Transfers.
Aeromodeller plans and publications, also books for A.T.C.
As no price lists are available, please state exact requirements, and enclose stamped addressed envelope.

402, PARK ROAD - - DINGLE, LIVERPOOL, 8
TRAMS Nos. 1, 3 and 20 pass the door.

HARPER OVERHEAD HEIGHT CHECK PATENT

- A simple yet effective training device carried readily in the waistcoat pocket. Over 10,000 now in use.
 - Gives the height of IDENTIFIED British, American and German aircraft flying overhead or almost overhead.
- Obtainable from: **FRANK HARPER** Price 4/- post free,
SOUTHCLIFFE, SELBY ROAD, FULFORD, YORK.

THE SCOTIA MODEL CO.

for
SUPER PLANS FOR R.A.F. AIR SEA LAUNCH (1/2 & 1/72 scale)

All the leading books for the Model Aircraft Builder
Enquiries must have stamped addressed envelope.

WE RECOMMEND . ELITE GLIDER. KITS.

40, Chambers Street, EDINBURGH, 1 Phone 32053

GREEN MAN GARAGE (WHETSTONE) LTD.

1308, High Road, Whetstone, London, N.20
(OPPOSITE TOTTERIDGE LANE)

We hold the Largest Stock of Aero Kits and Component Parts in North London.

Phone Hillside 3277. Stamped addressed envelope for replies.

LONDON—TOY AND MODEL SHOP

Keil Kraft, Astral, Halifax, Skyleada, Skyrova, Airyda, Grace Airplanes
Modelcraft Airlines, Skycraft, Silverwing,
Waterline and Leyden Ship-Kits.

Plans and Aero-modeller books stocked, but no wood.
Postage must accompany Orders and enquiries.

57, SYDENHAM ROAD, LONDON, S.E.26
SYD 8320

SCOTLAND CALLING!

FRANK ROYLE, 54, South Clerk St., EDINBURGH
IS AT YOUR SERVICE

Largest Selection of Kits, etc. in Scotland.

OUR SPECIALITY: Cockpit Covers.

Send Stamped Addressed Envelope for List.

A. A. BAKER, 526, High Road, CHISWICK, W.4

British and Foreign Transfer Insignia, Cockpit Covers,
Turrets, Wheels, and other accessories.

Stockists of all leading makes. Super-detailed "Wing" Series solid
Blue Prints, including Whirlwind, Thunderbolt, Focke Wulf 193,
ME 110, C5, etc. Stamp brings reply

SYD TONGE, 92, Winchcombe St., CHELTENHAM'S
MODEL AND ACCESSORIES HOUSE

Including postage. Monthly Aeromodeller, 1/2; Radio Control, 2/4;
Flying Boats, 2/4; McGillicuddy's Year Book, 3/10; Camouflage, 14-18,
Aircraft, 3/10; Petrol Engines, 3/4; Airscrews, 2/4; Solid Scale Model,
4/4; Design and Construction of Flying Model Aircraft, 10/9; Scale
Model Aircraft Buildings, 8/10; Building Galleons, 12/8 Cockpits,
Props, Dopes, Brushes, etc. **MANUFACTURERS' ENQUIRIES INVITED**

J. CHAPPELL,

339, ECCLES NEW ROAD, SALFORD 5, LANCs.

1/72 SOLID KITS, Walrus, 3/9; J.U. 87B, Lightning, Thunderbolt, 3/-;
Gladiator, Lysander, Messerschmitt 109F, 2/6

COCKPIT AND TURRET SETS. Fortress II, 2/6; Mitchell III, 2/-;
Halifax, 2/-; Marauder, 2/-; Sunderland, 1/6; Mosquito, 1/-;
Curtiss Helldiver, 1/2

GALLEON BLUE PRINTS. "H.M.S. Victory," 22"; "Golden
Hind," "Santa Maria," "Curry Sark," 22".
With Instructions. All 3/6. Post 3d.

The model for the enthusiast. "Celestial Horseman"
by L. G. Temple. Span 10' 4.3" Size of plan 70" x 40"
Price 8/3

OTHER GLIDERS



The Seal of Successful Modelling

AEOLUS
A.P.6
ATALANTA
CRACOW
CURLW
ELMIRA
FIGHTER GLIDER
IVORY GULL
KING FALCON
KIRBY KITE
LEANDER
R.F.L.G. 53
STOTHERS GLIDER
SUNCLIPPER
TEMPLE SOKOL
TEMPLE TRIBUTE

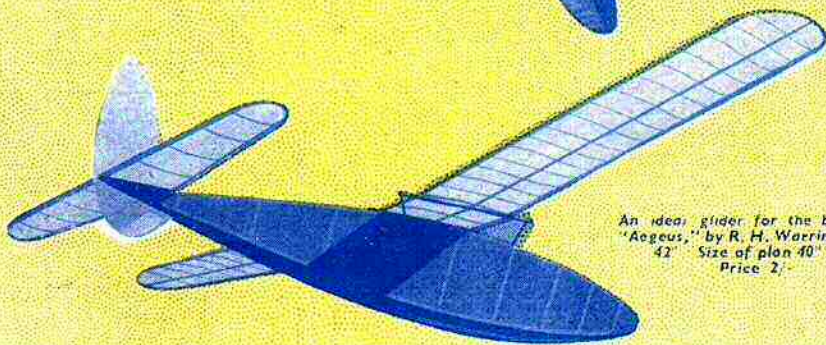

An ideal glider for the beginner.
"Aegeus," by R. H. Warring. Span
42" Size of plan 40" x 20"
Price 2/-

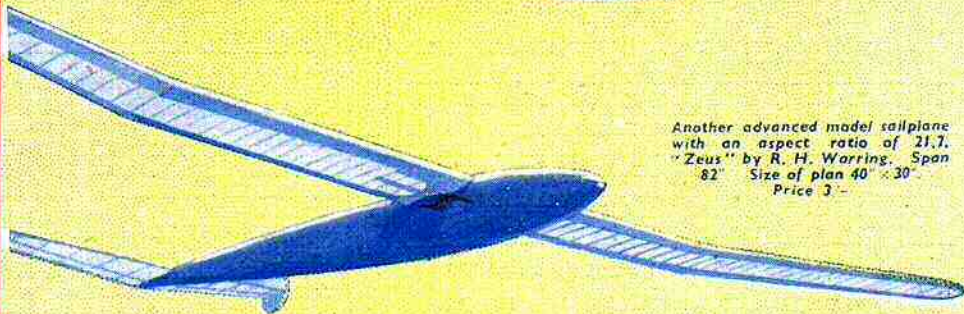

Another advanced model sailplane
with an aspect ratio of 21.7.
"Zeus" by R. H. Warring. Span
82" Size of plan 40" x 30"
Price 3/-

AEROMODELLER PLANS SERVICE, LIMITED

ALLEN HOUSE, NEWARKE STREET, LEICESTER